



**BNL-94867-2011-CP**

***PERFORMANCE OF THE DIAGNOSTICS FOR  
NSLS-II LINAC COMMISSIONING***

*R. P. Fliller III, D. Padrazo, G.M. Wang, R. Heese, H.-C. Hseuh, M. Johanson,  
B.N. Kosciuk, I. Pinayev, J. Rose, T. Shaftan, O. Singh*

*Presented at the 2011 Particle Accelerator Conference (PAC'11)  
New York, NY  
March 28-April 1, 2011*

March 2011

**Photon Sciences Directorate**

**Brookhaven National Laboratory**

**U.S. Department of Energy  
DOE - Office of Science**

Notice: This manuscript has been authored by employees of Brookhaven Science Associates, LLC under Contract No. DE-AC02-98CH10886 with the U.S. Department of Energy. The publisher by accepting the manuscript for publication acknowledges that the United States Government retains a non-exclusive, paid-up, irrevocable, world-wide license to publish or reproduce the published form of this manuscript, or allow others to do so, for United States Government purposes.

This preprint is intended for publication in a journal or proceedings. Since changes may be made before publication, it may not be cited or reproduced without the author's permission.

## DISCLAIMER

This report was prepared as an account of work sponsored by an agency of the United States Government. Neither the United States Government nor any agency thereof, nor any of their employees, nor any of their contractors, subcontractors, or their employees, makes any warranty, express or implied, or assumes any legal liability or responsibility for the accuracy, completeness, or any third party's use or the results of such use of any information, apparatus, product, or process disclosed, or represents that its use would not infringe privately owned rights. Reference herein to any specific commercial product, process, or service by trade name, trademark, manufacturer, or otherwise, does not necessarily constitute or imply its endorsement, recommendation, or favoring by the United States Government or any agency thereof or its contractors or subcontractors. The views and opinions of authors expressed herein do not necessarily state or reflect those of the United States Government or any agency thereof.

# PERFORMANCE OF THE DIAGNOSTICS FOR NSLS-II LINAC COMMISSIONING\*

R. P. Filler III, D. Padrazo, G.M. Wang, R. Heese, H.-C. Hseuh, M. Johanson, B.N. Kosciuk, I. Pinayev, J. Rose, T. Shaftan, O. Singh, Photon Sciences Directorate BNL, Upton, NY, 11973, U.S.A.

## Abstract

The National Synchrotron Light Source II (NSLS-II) is a state of the art 3-GeV third generation light source currently under construction at Brookhaven National Laboratory. The NSLS-II injection system consists of a 200 MeV linac, a 3-GeV booster synchrotron and associated transfer lines. The transfer lines not only provide a means to deliver the beam from one machine to another, they also provide a suite of diagnostics and utilities to measure the properties of the beam to be delivered. In this paper we discuss the suite of diagnostics that will be used to commission the NSLS-II linac and measure the beam properties. The linac to booster transfer line can measure the linac emittance with a three screens measurement or a quadrupole scan. Energy and energy spread are measured in a dispersive section. Total charge and charge uniformity are measured with wall current monitors in the linac and transformers in the transfer line. We show that the performance of the diagnostics in the transfer line will be sufficient to ensure the linac meets its specifications and provides a means of trouble shooting and studying the linac in future operation.

## INTRODUCTION

The National Synchrotron Light Source II (NSLS-II) is a state of the art 3 GeV third generation light source currently under construction at Brookhaven National Laboratory. The NSLS-II injection system consists of a 200 MeV linac and a 3 GeV booster synchrotron and associated transfer lines. Commissioning of the linac is scheduled to begin by the end of this calendar year. The linac to booster transfer line is integral to the commissioning effort as it provides the suite of diagnostics that will be used for this effort.

The linac is being produced by Research Instruments GmbH. It operates in two modes. The first mode is long pulse mode where the linac will produce 15 nC in 80-150 bunches separated by 2ns. In the second mode the linac will produce a short series of bunches each with 0.5nC. The geometric emittance of the beam is specified to be  $4\sigma_x\sigma_x=150$  nm, with 0.5% energy spread.[1]

In this paper we discuss the capabilities of the transport line as they relate to linac commissioning. First we discuss the layout of the transport line and installation plans. The diagnostics are discussed. We show simulations of measuring the beam emittance and energy spread with the beam flags. Finally we show optics studies of the transport line with a variety of optics from the linac.

## LAYOUT

The linac to booster transport line is shown in Figure 1. It consists of a short matching section, a dispersive section for energy selection which includes an energy slit, followed by a matching section into the booster. Two beam dumps are used during linac commissioning and studies. The straight ahead beam dump line is equipped to measure the transverse emittance via a three screens or quadrupole scan. The second beam dump line is equipped with a flag to measure the energy spread of the linac.

The transport line is equipped to allow access to the booster vault while the linac is operating to one of the dumps. This is accomplished by interlocking off the second bending magnet and including a safety shutter in the section going into the booster vault.

Installation will proceed in two stages. The first part will include all portions of the transport line in the linac vault, through the penetration up to first vacuum valve in

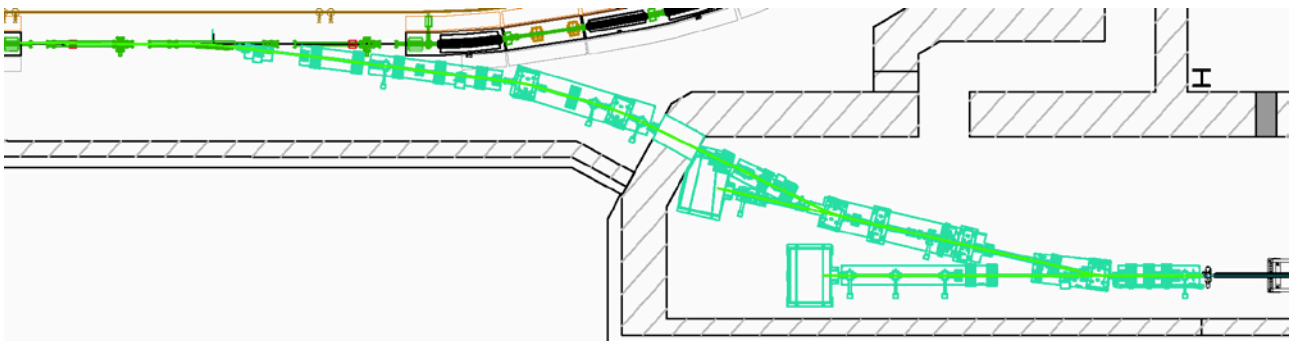

Figure 1: Linac to Booster Transfer Line

\* This manuscript has been authored by Brookhaven Science Associates, LLC under Contract No. DE-AC02-98CH10886 with the U.S. Department of Energy.  
\*rfiller@bnl.gov

the booster vault. The remaining sections of the transport line will be installed with the booster. By ending the first part of the installation with a valve, we can operate the transport line independent of subsequent installation without bleeding up of the first section.

### TRANSPORT LINE DIAGNOSTICS

Type	Quantity	Resolution	Parameter
Flag (OTR/YAG)	9	10/30 $\mu$ m	Energy spread, beam size, position
FCT	2	.6pC/bunch	Fill pattern
ICT	2	10pC/train	Bunch Charge
Energy Slit	1	n/a	n/a
BPM	6	30 $\mu$ m	Beam Position
Faraday Cup	2	n/a	Bunch Charge

Table 1: Synopsis of Linac to Booster Transport line diagnostics.

Table 1 shows the available diagnostics in the linac to booster transfer line..

There are nine flags in the transport line, placed at strategic locations for beam measurements and commissioning. A conceptual design of the flag is shown in Figure 2. The varying density of charge requires implementation of a flag with dual screens. The optical transition radiation (OTR) screen is used for high charge density, and is made of aluminium or stainless steel and is approximately 1 mm thick and will be at 45 degrees to the beam. For low charge density, a fluorescent screen will be used, comprised of YAG:Ce, and is between 50 to 200  $\mu$ m thick, utilizing normal incidence to the beam. An actuator is implemented to drive a flipping mechanism to move the viewing screens in and out of beam path. A virtual target is illuminated as a means to provide spatial calibration and focusing. A sapphire window is used on the dedicated viewing port, whereby a camera will be placed outside the median plane.



Figure 2: Conceptual design of the beam flag that will be produced by Radiabeam Technologies

A Bergoz Fast Current Transformer will be used for fill pattern monitoring.[2] A Bergoz ICT/BCM will provide a multiply time integral output, which is proportional to the beam pulse charge.[3] Each beam dump is equipped as a Faraday cup to measure charge per bunch train.

An Energy Slit will be placed at the maximum dispersion location in the achromat, to remove any off energy particles.

Six beam position monitors are placed throughout the transport line. The first is at the end of the linac. One exists near the maximum dispersion location in the dispersive section for online energy measurement. Four BPMs are in the matching section for matching into the booster. The BPM system tracks the position of the beam by measuring the levels of the signals induced on the BPM pick-up electrodes. The signals are delivered to the receivers inside the temperature controlled rack outside the tunnel. The BPM pick-up electrodes will be placed on two types of vacuum chamber. The first type (Figure 3) has a round vacuum chamber with inner diameter of 40 mm; the second type (Figure 4) has an elliptical cross-section with vertical aperture of 40 mm and horizontal aperture of 90 mm.

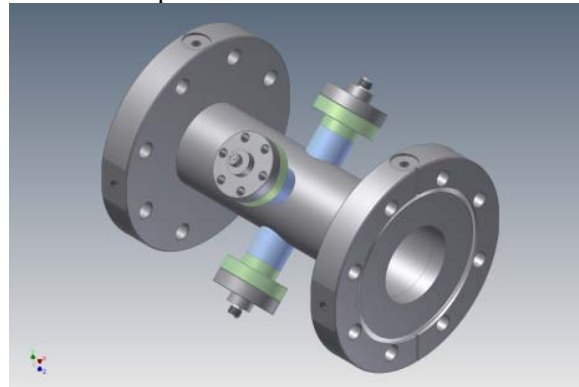

Figure 3: Design of the round BPM housing.

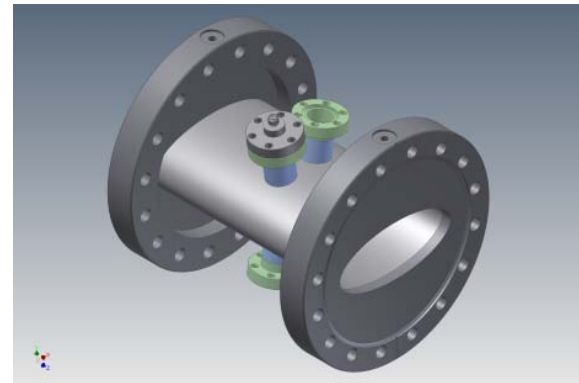

Figure 4: Design of the elliptical BPM housing.

There is also a Safety Shutter placed before the exit of the linac vault that will allow safe operation of the linac independent of the status of the booster.

## BEAM EMITTANCE MEASUREMENT

The beam emittance is measured in the first beam dump straight ahead of the linac. There are five quadrupoles and 4 flags. A schematic of the layout is shown in Figure 5. Flags A, I, and B shown in Figure 5 are separated by 1 m each. The beam emittance can be measured using a three screens measurement with these flags, or a quadrupole scan. The Twiss functions can also be extracted with this information.



Figure 5: Layout of the transport line to the first dump. Beam enters from the left side.

We used T-Step to simulate the linac and ELEGANT to simulate a three screens measurement in this beamline.[4,5,6] The optics of the beamline were adjusted to minimize measurement errors, which results in the beta functions at flag “I” to be one half of that at flags “A” and “B”. Table 2 shows the results of the simulations.

Table 2: Results of Three Screens Simulations.  $\beta$  and  $\alpha$  are measured at flag I.

Parameter	Horizontal Plane		Vertical Plane	
	Input	Simulation	Input	Simulation
Emittance (nm)	42	45±8	42	44 ±8
$\beta$ (m)	1.25	2.5±0.7	1.25	1.9±0.5
$\alpha$	0	-0.11±0.05	0	-0.15±0.07

## ENERGY SPREAD MEASUREMENT

The energy and energy spread measurement is performed in the second beam dump line. Figure 6 shows the layout from linac exit to dump 2. Downstream of the first dipole are a BPM and two flags that can be used to measure the beam energy. There is also a FCT that will be used to measure the fill pattern.

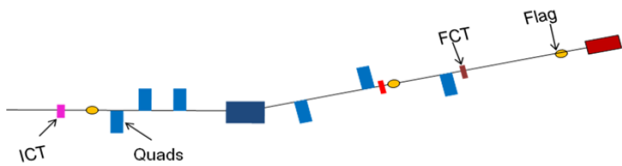

Figure 6: Layout of the transport line to the second dump. Beam enters from the left side.

The dipole is 30 cm long with a bend angle of 225 mrad which provides sufficient dispersion for these measurements. The three quadrupoles before the dipole and two quadrupoles after the dipole will be used to manipulate the dispersion function and  $\beta$  functions so that the beam size measured on the flags is highly dominated by the beam’s energy spread. The energy can be

extracted from the horizontal position from the BPM or the position in either flag.

Figure 7 shows a simulation of the beam size on the first flag after the dipole, where the dispersion is 0.87 m. The measured energy is  $203 \pm 3$  MeV consistent with the linac output of 203.3 MeV. The energy spread is  $0.45\% \pm 0.08\%$  consistent with the linac output of 0.46%

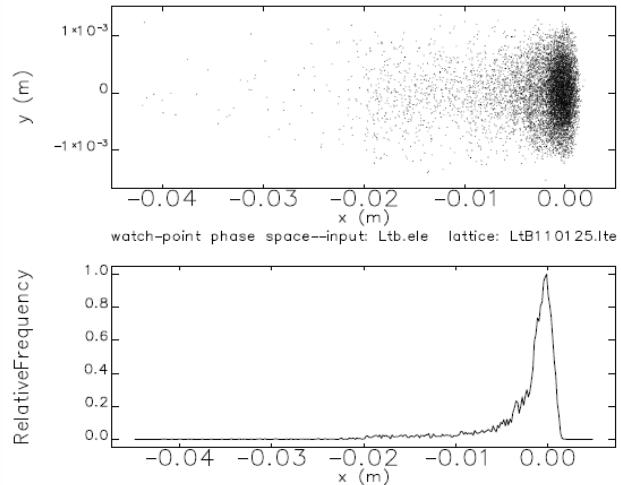

Figure 7: Upper figure is a simulation of the beam spot on the flag prior to the second beam dump. The lower plot is the projection on the horizontal axis.

## CONCLUSION

We have presented a robust design for the NSLS-II linac to booster transport line. It contains sufficient diagnostics to fully characterize the beam from the linac. We show start to end simulations of the linac and transport line which confirm that the diagnostics suite is sufficient for commissioning the linac.

Installation is set for the fall of this year for all parts in the linac vault and the penetration into the booster tunnel. The remaining parts of the transport line will be installed after booster installation.

## REFERENCES

- [1] J. Rose. “Technical Specifications for the 200 MeV Linear Accelerator”. NSLS-II Document Number LT-RSI-SR-RF-001.
- [2] [http://www.bergoz.com/index.php?option=com\\_content&view=article&id=23&Itemid=28](http://www.bergoz.com/index.php?option=com_content&view=article&id=23&Itemid=28)
- [3] [http://www.bergoz.com/index.php?option=com\\_content&view=article&id=29&Itemid=37](http://www.bergoz.com/index.php?option=com_content&view=article&id=29&Itemid=37)
- [4] L. Young. “TStep”. Copyright 2006-2009.
- [5] K. Dunkel. “3200 BNL 200 MeV Linac”. Reserach Instruments Gmbh. Document Number 3200-BP-8530-B.
- [6] M. Borland, “Elegant: A Flexible SDDS-Compliant Code for Accelerator Simulation,” Advanced Photon Source LS-287, September 2000.

