

Lab-Based Measurement of Remediation Techniques for Radiation Portal Monitors (Initial Report)

Jake Livesay, PhD
Oak Ridge National Laboratory

Introduction

Radiation Portal Monitors (RPM) deployed by the Second Line of Defense (SLD) are known to be sensitive to the natural environmental radioactive background. There are several techniques used to mitigate the effects of background on the monitors, but since the installation environments can vary significantly from one another the need for a standardized, systematic, study of remediation techniques was proposed and carried out.

This study is not meant to serve as the absolute last word on the subject. The data collected are, however, intelligible and useful. Some compromises were made, each of which will be described in detail. The hope of this initial report is to familiarize the SLD science teams with ORNL's effort to model the effect of various remediation techniques on simple, static backgrounds. This study provides a good start toward benchmarking the model, and each additional increment of data will serve to make the model more robust.

The scope of this initial study is limited to a few basic cases. Its purpose is to prove the utility of lab-based study of remediation techniques and serve as a standard data set for future use. This importance of this first step of standardization will become obvious when science teams are working in parallel on issues of remediation; having a common starting point will do away with one category of difference, thereby making easier the task of determining the sources of disagreement. Further measurements will augment this data set, allowing for further constraint of the universe of possible situations.

As will be discussed in the "Going Forward" section, more data will be included in the final report of this work. Of particular interest will be the data taken with the official TSA lead collimators, which will provide more direct results for comparison with installation data.

Current Work

A test bed, the Portal Monitor Test Bed (PMTB), was constructed for the direct measurement of the remediation techniques proposed by ORNL. This report will discuss the various remediation configurations that have been tested (up to this time) as well as some of their inherent limitations. The PMTB consists of one RPM, one 40-foot cargo container, one set of steel ramps, one set of steel plates (henceforth 'shadow shields'), two sets of collimators (one steel, and one lead), and six interlocking half-slabs of concrete with varying inherent levels of radioactivity.

The slabs are 12" thick and sit atop the ground between the pillars of the RPM to simulate repaving. The transmission of the underlying, natural radiation has been directly measured and simulated using MCNP. In both cases the effect of the underlying radiation on the background countrate of the monitor has been negligible.

The general plan, laid out in the 'ORNL Remediation Techniques' document, was to measure the RPM background countrate for each configuration of slabs, collimators, and shadow shields. This data will then be compared to MCNP calculations to determine the reliability of modeling, and its eventual predictive capability based on a careful background survey of the RPM location.



Setup of the Test Bed

The PMTB is a simple setup which involves as few complications as is reasonably achievable. A RPM is erected on a steel pallet (as well as a spacer to adjust the height) in a parking lot of uniform background. All data is collected in a nearby instrument trailer – the difference in background due to the trailer is negligibly small, due to its size and location. Changing the configuration of the PMTB proceeds by involving craft-workers to change the slabs, stand-up and take-down the shadow shields, install or remove the RPM spacers, and install or remove collimation.



Each background data point was collected by taking the average of the static portion of each detector's count rate during each configuration. One of the challenges of this work is finding a long enough period without rain, from which to extract such a value. For this reason (and a few other operational issues), the time between data points varied from 1 to 5 weeks, making the total time for the measurements somewhat longer than anticipated. Now that the process has been in practice for more than a year, future measurements are expected to take less time - weather permitting, of course.



Collimation

It must be understood that the collimators used for this report were steel, not lead, and are thus not directly representative of the collimators deployed by SLD. Data is currently being taken with lead collimators, and will be presented in the final version of this report. Nevertheless, these collimators are just as useful as any other collimator from the perspective of modeling– the primary importance of the MCNP model is its ability to closely match the field-data.

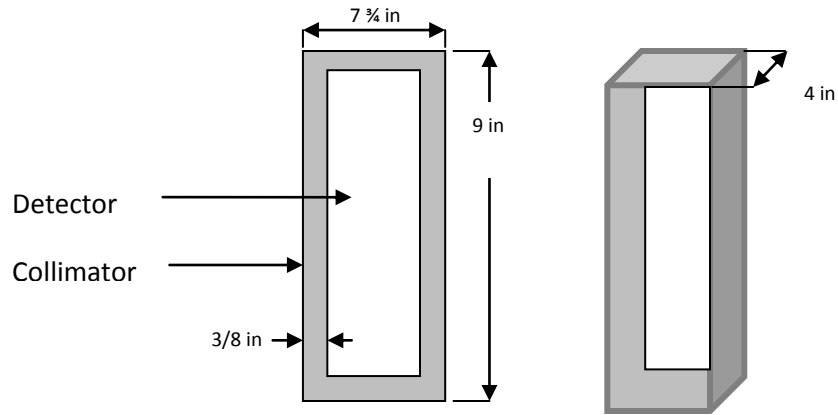
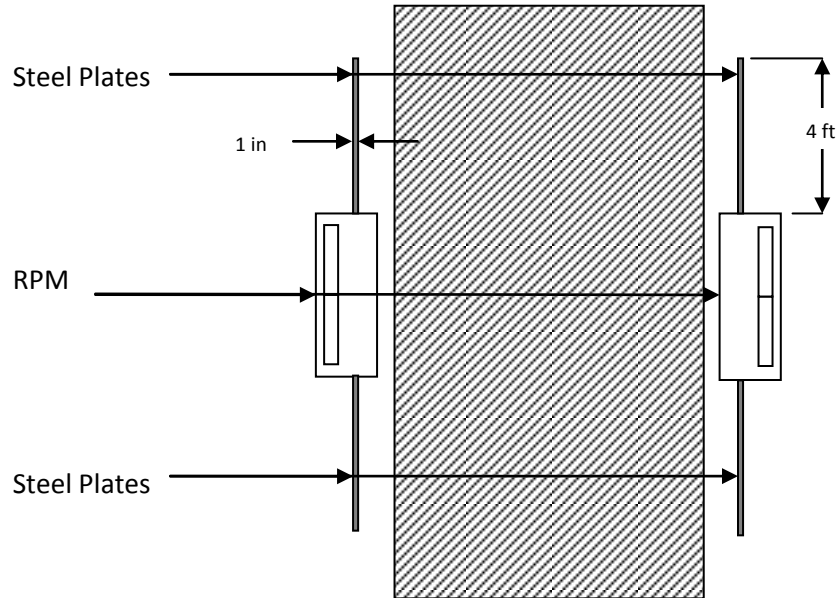

Figure 1. Diagrams of Collimator.

Steel Plates

There are some situations in which one (or both) pillar(s) of a RPM are unintentionally measuring sources behind the opposite pillar. Examples of this include crosstalk (neighboring lanes of traffic), radioactive buildings or building materials, and known sources such as NII (active interrogation) instruments. In the current data set, as can be seen from the data (below), these shadow shields have little effect on the background, as expected.



In order to make the best use of this particular remediation technique, the “hot slab (G)” should be placed behind one of the pillars to simulate the expected real-world effect of non-uniform paving.

Repaving

Suffice it to say that actually repaving a patch of ground is a prohibitive administrative challenge at ORNL, so an alternative was implemented. Three slabs of varying amounts of granite (and therefore varying amounts of uranium) were commissioned. Each slab is, strictly speaking, two half-slabs which are fitted together with staggered step-cuts (this allows for the mixing of half slabs, which has not currently been performed), and they are 1-foot thick to block the background from directly beneath themselves (an important step for the correct accounting of the background contribution from the slabs, as opposed to the ground).

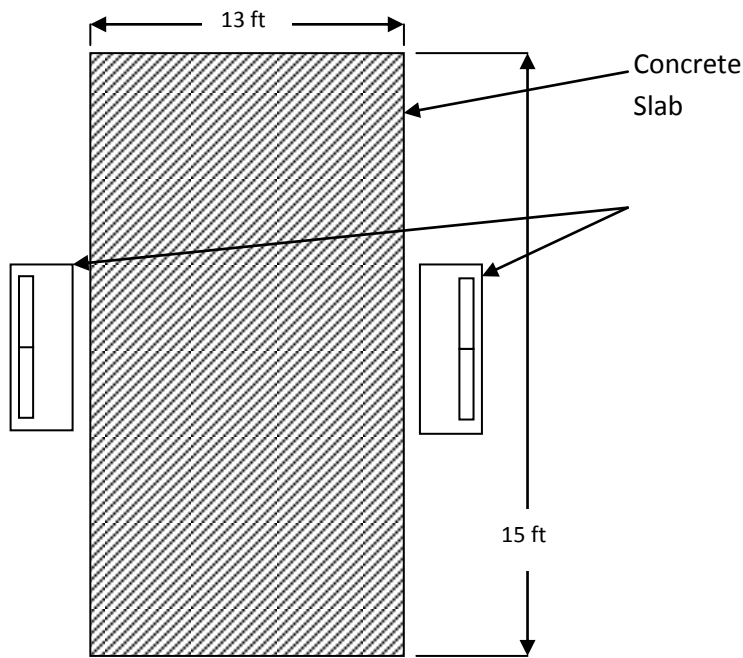

Figure 2. Diagram of Repaving Scenario.

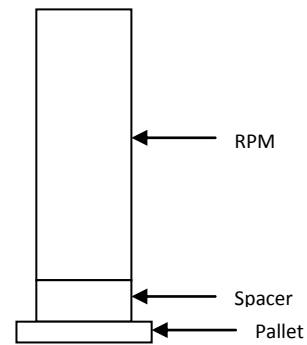

Figure 3. Side View of Elevated RPM.

Some Results

Each configuration of remediation techniques was assigned a code, or “configuration index”, to simplify visualization of the data. The general pattern of the configuration index is seen in table CI – a “zero” indicates that a particular remediation technique is not included in that configuration, while a “one” indicates that a technique is included in that configuration. (Note that the letter associated with each slab F, G, or H is used in place of the 0 or 1 for the slab field of the configuration index).

Configuration Index	Slab	Ramps	Collimators	Shadow Shields
0000	0	0	0	0
1000	1	0	0	0
1010	1	0	1	0
1011	1	0	1	1
1001	1	0	0	1
1110	1	1	1	0

Most configurations have been measured for two slabs, G and F. The results can be seen in Tables G and F, as well as in plots G and F. It’s important to notice that for Configuration Index values that include collimation (4 and 5), only the master side of the RPM was collimated, which allows for the direct comparison of the two pillars for the same time period, with and without collimation.

Slab G

The data collected for “Slab G” displayed in the table and the graph are sorted from the largest average background to smallest average background. Each value is reported as the ratio of the average background for that configuration, to the “un-remediated” average background. That is, each detectors background is divided by its own background, without any remediation techniques applied.

Slab G is the hottest slab among the three available slabs. As can be seen from the first row of the table (and the left-most data points in the plot), the two lower detectors (detectors 1 and 3) measured a background which is about twice the natural background – an expected result, since the two lower detectors are closest to the slab. This situation is of particular interest to installations in which the pavement between the pillars of a RPM is hotter than the surrounding environment.

The most effective remediation technique in this case has the Configuration Index G011, which means the detectors were collimated and the shadow shields were erected. Keeping in mind that only the master pillar is collimated, the effect of collimation (with steel collimators) on the lower detector is $1.40/1.90 = 0.74$, which means that the background was reduced by 26%. For the master upper detector: $1.16/1.60 = 0.73$, which is a reduction of 27%.

G000	1	1.90	1.60	2.00	1.61
G010	2	1.81	1.51	1.92	1.55
G110	3	1.80	1.49	1.89	1.51
G001	4	1.57	1.31	2.04	1.64
G011	5	1.40	1.16	1.87	1.49

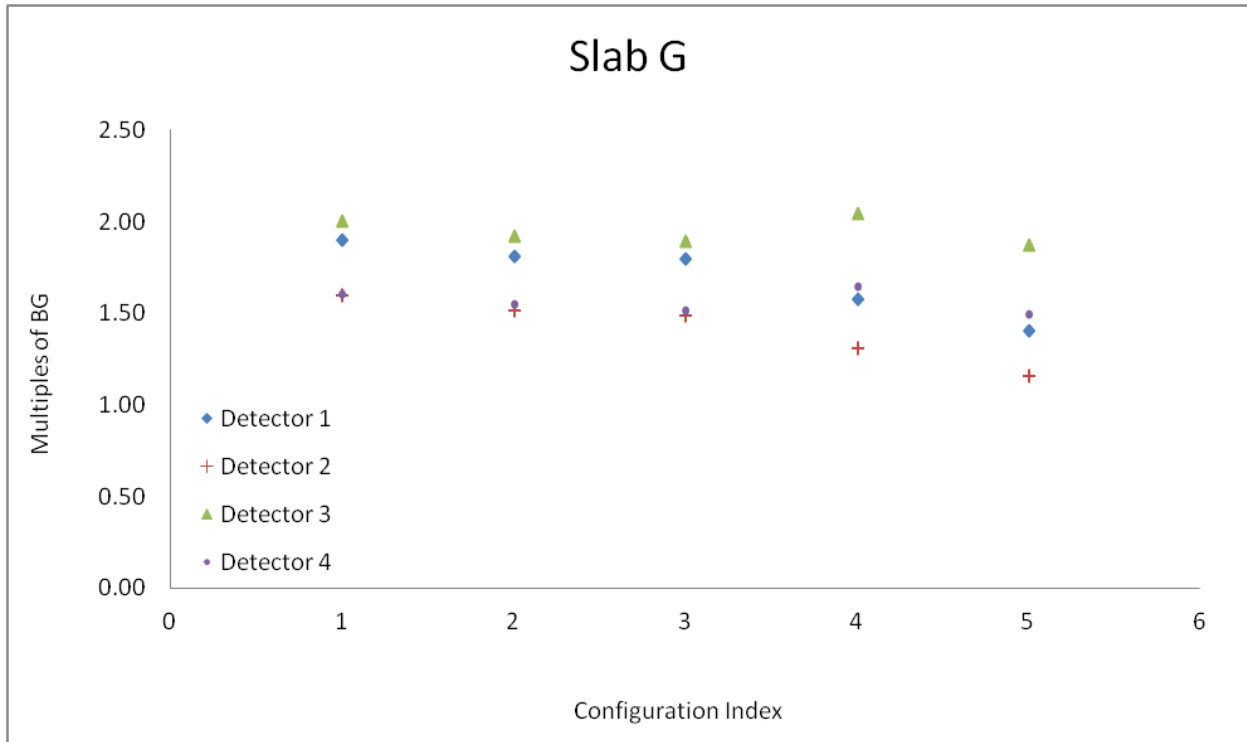

While this reduction is significant, it's important to realize that due to the location of the source (the slab is directly between the monitors), no remediation technique will totally ignore the radioactivity of the slab.

A greater reduction in background is expected with lead collimators, and these results will be shared in the final report.

Slab F

The data collected for “Slab F” displayed in the table and the graph are sorted from the largest average background to smallest average background. Each value is reported as the ratio of the average background for that configuration, to the “un-remediated” average background. That is, each detectors background is divided by its own background, without any remediation techniques applied.

Not every case seen in the data for Slab G is seen in the data for Slab F. More of these points will show up in the final report.

F000	1	0.99	1.00	0.99	0.99
F010	2	0.88	0.90	0.88	0.90
F110	3				
F001	4				
F011	5	0.70	0.68	0.87	0.89

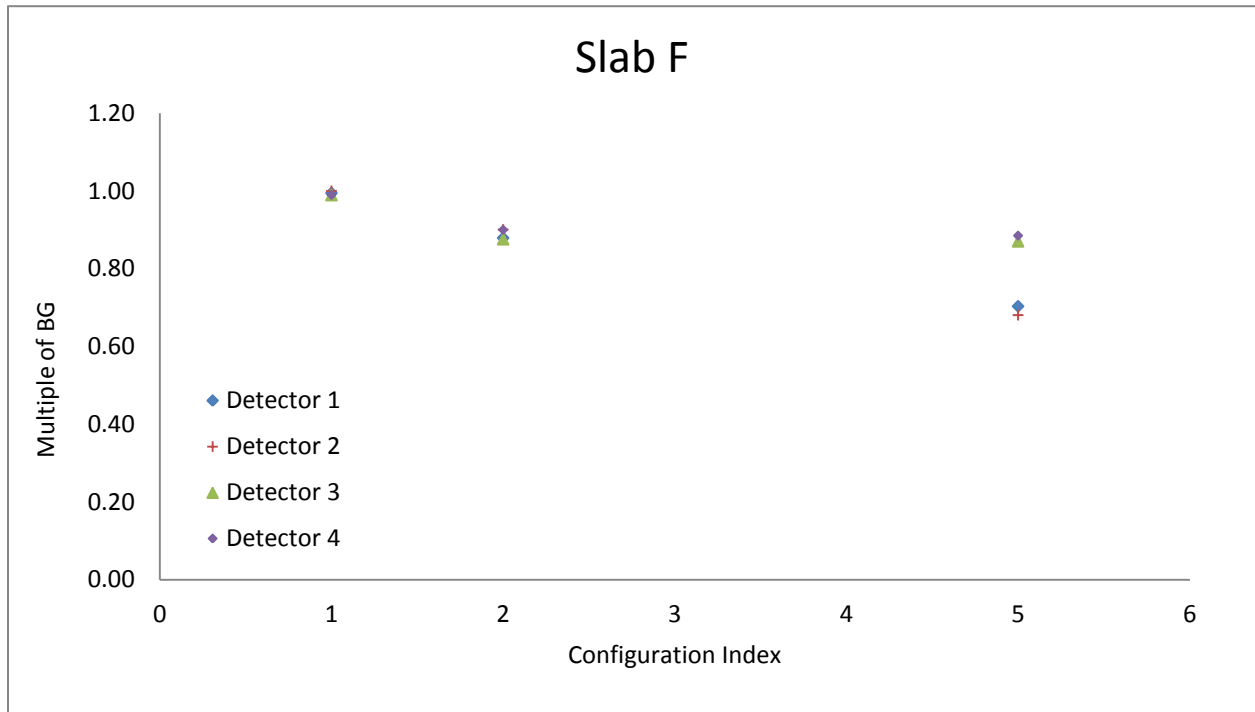

The intrinsic radioactivity of Slab F is very close to the background around it, as evidenced by the first row of the table, and the first points on the plot, where the ratio for each detector is equal to 1. That is, the radioactivity taken away by the slab (by covering the ground beneath) is replaced by the radioactivity of the slab itself.

MCNP Model (and some early results)

The Test Bed has been modeled in MCNP, with the ultimate purpose of using the simulated results to predict which, if any, background remediation techniques will be needed for any given RPM. The first comparison of the Test Bed data and MCNP simulation is seen in Plot GF.

In this case the background countrates from two configurations, each of which had only a slab in place (i.e. Configuration Index 1000), are subtracted to 'ignore' the natural background (which should be the same between the two situations). Good agreement between the data and the simulation can be seen – with the maximum difference being about 14%.

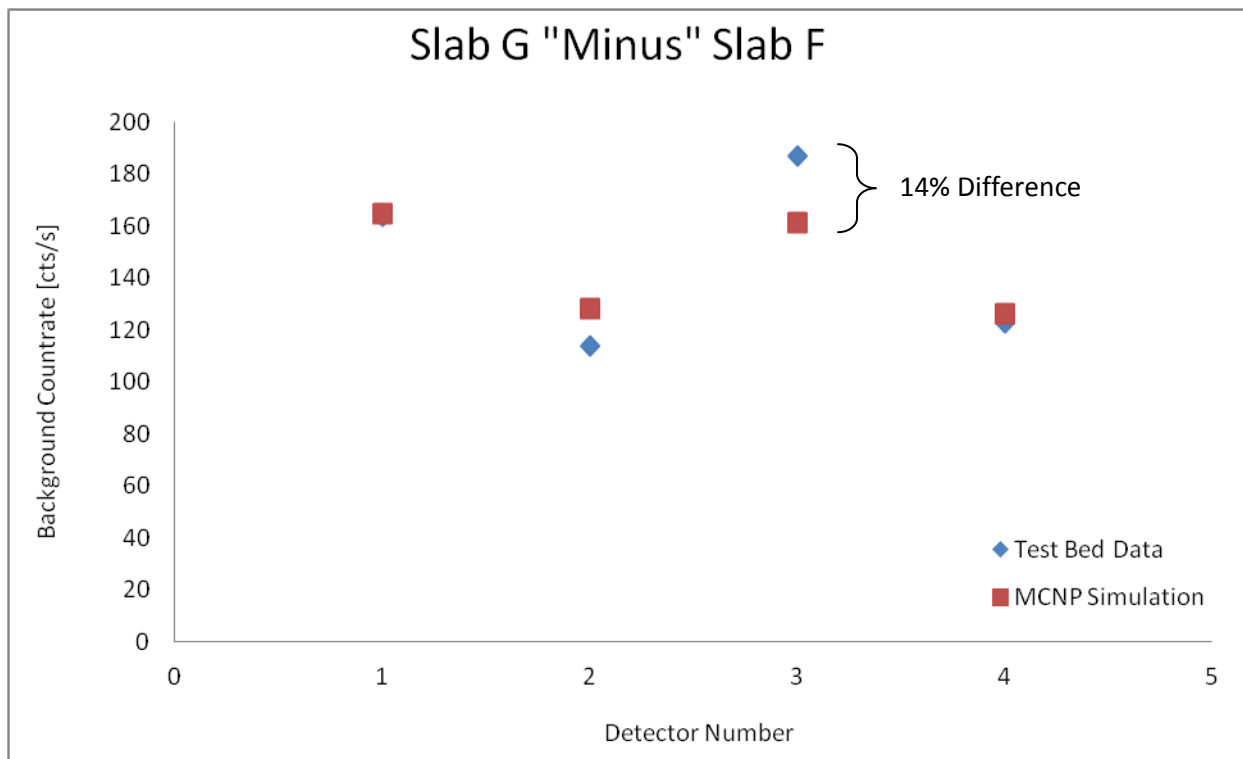

In the final report of this work there will be comparisons between each measured data point, with each MCNP simulated data point.

The next step in modeling the physics of the environment around and RPM are shown below (marked MCNP "G"). It's important to notice that these calculations do not report the actual countrates. These calculations are the ratios of the countrates of each configuration to the un-remediated RPM, so they can be directly compared to the measured data.

As can be seen, the results of this model do a good job of predicting the effects of the hot slab "G" on the background, as well as the remediation effects (compare with the data for Slab G, above). One sticking point in this set of results is that it doesn't show the difference in the upper and lower detectors, which was measured in the actual RPM. This difference does not currently have a resolution, but is under investigation.

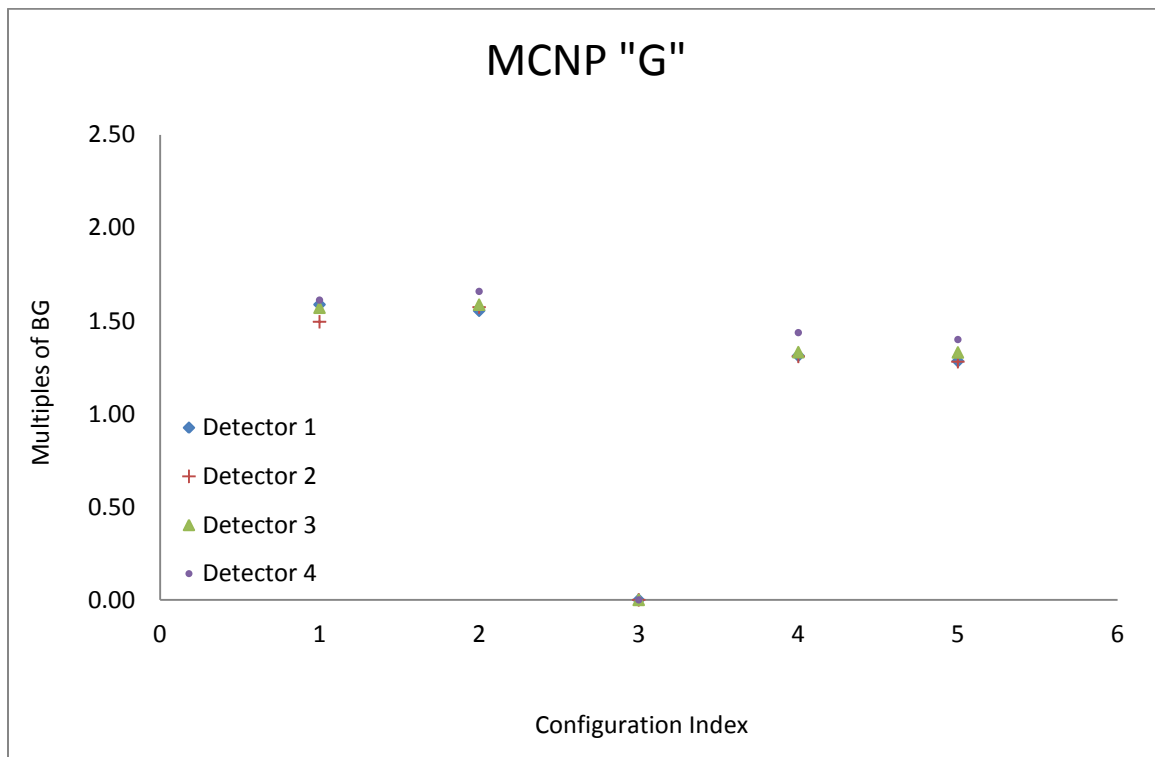

Going Forward

This report is preliminary, since it does not include all the MCNP simulations required to give a final result or the data taken with the official TSA lead collimators – these results will appear in the final version of the report. So, the first step in going forward will be to finalize this report and give clear interpretations of the results. The data can then be shared with other science teams to use in their models of background remediation techniques.

In terms of further measurements: the mapping of a cargo container's effect on the background (with and without a source) for each configuration of background remediation techniques is a worthy goal. Making a set of measurements with the 'hot' slab "G" would be useful for further benchmarking the MCNP model.

Appendix A

This section explains how to get extract representative background data from a data set that's complicated by 'environmental' factors such as rainfall and external sources (e.g. calibration sources and unknown sources passing by on the nearby road).

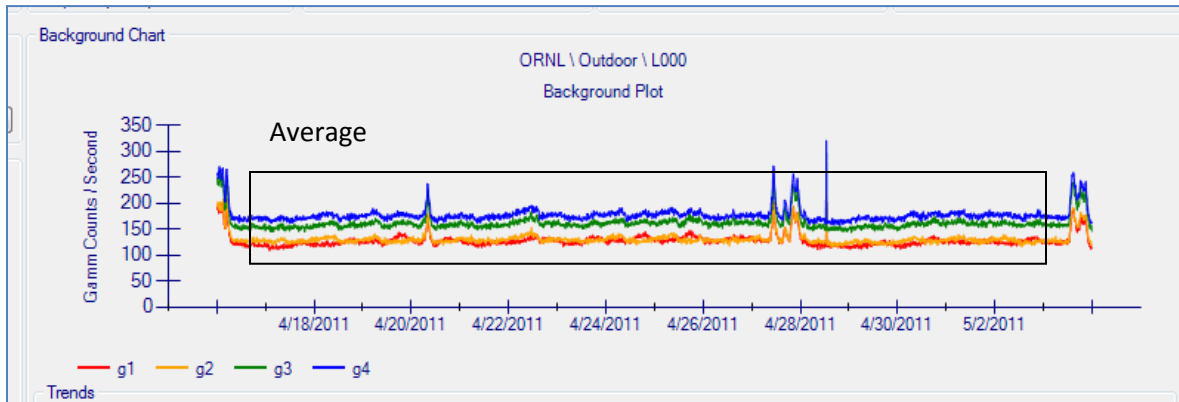

For the simple example shown here, there are several instances of environmental effects, on the following dates: 4/16, 4/20, 4/27, 4/28, and 5/3. In order to report accurate background averages these fluctuations must be thrown out. This can be done by simply averaging the averages of the background countrates between these events, shown graphically below.

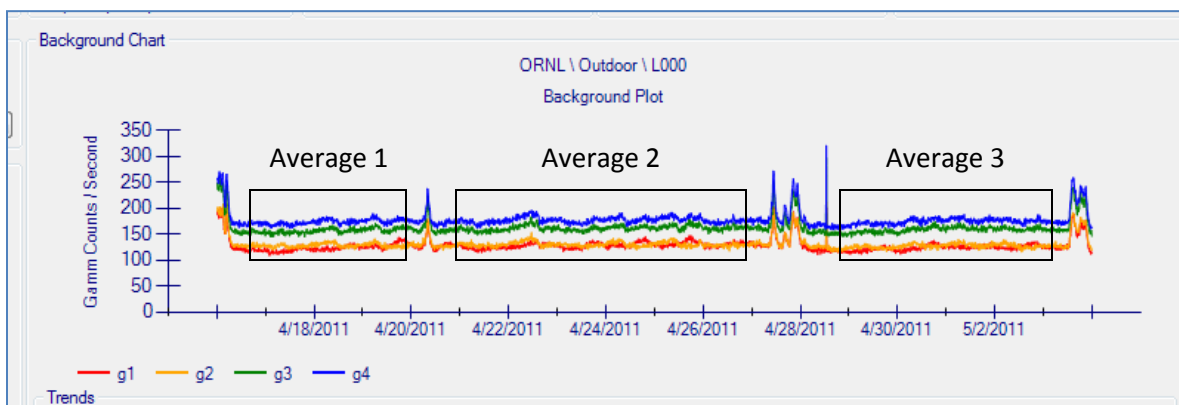

Appendix B

This section discusses how to perform a background survey. This information will not only satisfy the current installation guidelines, but will also strengthen the MCNP model and help to avoid repeated visits and analysis-headaches in the future.

The hope is simply to begin assimilating more data from the field and including it in predictions of background issues, as well as in designing remediation techniques. While the best way to take data is with a collimated High Purity Germanium Detector, this will not always be available, so the MCNP code will be able to handle PRM 470 results as well.

The main point to take away from this drawing is that the background survey should form a grid, with the RPM (or proposed RPM) at its center. What's shown here is the simplest case, in which a lone RPM stands in a field of unshielded background emanating solely from natural radioactivity in the soil and building materials. It's abundantly clear that the real world is often (if not always) more complicated and challenging than this. However, the simple rule of thumb is simply 'when in doubt, take more data'. If a low concrete wall is nearby, take a reading. If there appears to be an abrupt change in the pavement, take a reading. If anything out of the ordinary is observed, take a reading.

