

*Omega-P, Inc.*

Final Report on DoE SBIR Phase I Grant DE-FG02-07ER84854

Topic 32b: Radio Frequency Power for Linear Accelerators

**MULTI-MW 22.8 GHz HARMONIC MULTIPLIER –  
RF POWER SOURCE FOR HIGH-GRADIENT ACCELERATOR R&D**

*Omega-P, Inc.*

291 Whitney Avenue, Suite 401  
New Haven, CT 06511

**MULTI-MW 22.8 GHz HARMONIC MULTIPLIER – RF POWER  
SOURCE FOR HIGH-GRADIENT ACCELERATOR R&D**

Final Report on Phase II DoE SBIR grant DE-FG02-07-ER-84854

Topic 32b: Advanced Concepts and Technology for High Energy Accelerators.

*Radio Frequency Power for Linear Accelerators*

J. L. Hirshfield, Principal Investigator

tel: (203) 789-1164, e-mail: [jay@omega-p.com](mailto:jay@omega-p.com)

**CONTENTS**

I.	INTRODUCTION	p. 2
II.	SUMMARY	3
III.	TECHNICAL APPROACH	4
IV.	STATUS OF HARDWARE DEVELOPMENT	22
V.	CONCLUSIONS	33
VI.	REFERENCES	33

Work on this project was carried out by Omega-P, Inc senior consultants Dr. V.P. Yakovlev, Dr. N. Solyak, and Dr. S.V. Kuzikov; by Dr. Y. Jiang and Dr. Sergey Shchelkunov working under a sub-grant to Yale University; and Dr. Jay L. Hirshfield, working as Principal Investigator.

July 30, 2012

*Omega-P, Inc.*

Final Report on DoE SBIR Phase I Grant DE-FG02-07ER84854

Topic 32b: Radio Frequency Power for Linear Accelerators

**MULTI-MW 22.8 GHz HARMONIC MULTIPLIER –  
RF POWER SOURCE FOR HIGH-GRADIENT ACCELERATOR R&D**

**I. SUMMARY**

Electrodynamic and particle simulation studies have been carried out to optimize design of a two-cavity harmonic frequency multiplier, in which a linear electron beam is energized by rotating fields near cyclotron resonance in a  $TE_{111}$  cavity in a nearly uniform magnetic field, and in which the beam then radiates coherently at the  $n^{\text{th}}$  harmonic into a  $TE_{n11}$  output cavity. Examples are worked out in detail for 7<sup>th</sup> and 2<sup>nd</sup> harmonic converters, showing RF-to-RF conversion efficiencies of 45% and 88%, respectively at 19.992 GHz (K-band) and 5.712 GHz (C-band), for a drive frequency of 2.856 GHz. Details are shown of RF infrastructure (S-band klystron, modulator) and harmonic converter components (drive cavity, output cavities, electron beam source and modulator, beam collector) for the two harmonic converters to be tested. Details are also given for the two-frequency (S- and C-band) coherent multi-MW test stand for RF breakdown and RF gun studies. Applications of this concept could include any requirement for high-power microwaves at a frequency for which there is no existing commercial tube.

*Omega-P, Inc.*  
Final Report on DoE SBIR Phase I Grant DE-FG02-07ER84854  
Topic 32b: Radio Frequency Power for Linear Accelerators  
**MULTI-MW 22.8 GHz HARMONIC MULTIPLIER –  
RF POWER SOURCE FOR HIGH-GRADIENT ACCELERATOR R&D**

## II. INTRODUCTION

Within Topic 32b from the DoE 2007 SBIR Program Solicitation, proposals were sought for "...the development of RF sources at K- to Ka-band, with a power level of ~50 MW, a pulse width of ~1  $\mu$ s, and a repetition rate of 100 Hz. The frequency stability and output spectrum must be suitable for driving a linac. Innovations that allow the source to be configured for different frequencies at low cost are of particular interest." Omega-P, Inc. submitted proposals and was awarded Phase I and Phase II grants DE-FG02-07 ER 84854 entitled "Multi-MW 22.8 GHz Harmonic Multiplier—RF Power Source for High-Gradient Accelerator R&D." This document constitutes a final report on the project, although continued work on the subject is planned by Omega-P and Yale University Beam Physics Laboratory.

The initial goal of the R&D program was to design during Phase I and build during Phase II a 45-50 MW, 22.8 GHz RF source, operating as a 2<sup>nd</sup> harmonic frequency multiplier using drive power from an 11.4 GHz SLAC klystron. Simulations shown in the Phase I proposal indicated, with 50 MW of X-band drive power and 50 MW of initial beam power (280 kV, 170 A), that over 47 MW of 22.8 GHz power could be generated, namely at a 95% RF conversion efficiency and 47% electronic efficiency [1]. This source was to be used for breakdown tests and accelerator structure development under the aegis of the then-nascent US Collaboration in High Gradient (HG) R&D, with SLAC as the host laboratory, and Professor Sami Tantawi of SLAC as the spokesperson for the HG Collaboration. The 22.8 GHz source was to be developed in collaboration with SLAC, to be formalized within a CRADA for the Phase II effort. The original plan was to install and operate the source at SLAC as part of its HG R&D program led by Professor Tantawi. The Marx HEPAP sub-panel [1] had just endorsed the building of stand-alone RF sources at frequencies different from those available at 11.424 GHz (SLAC and NRL), 17.1 GHz (MIT), and 34.3 GHz (Yale), to expand the range of frequencies for basic studies to achieve high acceleration gradients in warm structures. The proposed 22.8 GHz source would utilize an available electron gun and modulator. As it was based on a relatively-simple two-cavity structure, it was thought to be probably the least costly candidate for a new RF source for HG R&D. Furthermore, it was surmised that re-configuration of the 22.8 GHz source to operate at 34.3 or 45.6 GHz, namely at the 3<sup>rd</sup> or 4<sup>th</sup> harmonic of 11.424 GHz, could be achieved with modifications in design, involving replacement of only the output cavity and coupler.

This approach towards development of a new multi-MW RF source received initially-enthusiastic support from the HG community. However, in the intervening year between application for, and initiation of, the Phase I program, as high energy physics priorities and programs at SLAC and elsewhere shifted, willingness evaporated for making the commitment to use for this purpose a SLAC klystron with its modulator, plus a second modulator to power the harmonic multiplier's electron gun. Without such a commitment, the possibility of going forward with a Phase II program as originally-conceived was clearly impossible. Still, as interest in R&D towards achievement of high acceleration gradients in warm structures had not abated, need for suitable RF sources still persisted. Consequently, an alternative approach for building a harmonic multiplier was studied by Omega-P during Phase I, namely to design and ultimately build a K-band (18-26.5 GHz) source using as an RF driver an S-band klystron (2.856 GHz) and

*Omega-P, Inc.*

Final Report on DoE SBIR Phase I Grant DE-FG02-07ER84854

Topic 32b: Radio Frequency Power for Linear Accelerators

**MULTI-MW 22.8 GHz HARMONIC MULTIPLIER –  
RF POWER SOURCE FOR HIGH-GRADIENT ACCELERATOR R&D**

modulator available at the Yale Beam Physics Laboratory. This would mean that the harmonic index, instead of two, would be much larger, namely seven through nine, corresponding to K-band outputs at 19.992, 22.848, and 25.704 GHz. But, with these higher harmonic interactions, more complex mode selection and output coupler designs would be required, and lower RF conversion efficiencies would be expected. Still, the prospect of building multi-MW sources for HG R&D at frequencies where no other high-power source exists remained attractive, albeit with single-digit rather than double-digit MW's. Use of higher harmonic indices does not alter the possibility of designing a demountable source, in which the electron gun, S-band drive cavity, magnetic field system, and beam collector would remain fixed; while output cavities at desired harmonic frequencies could be built and installed (one at a time) to extract useful levels of RF power from the beam. In the Phase I work, a detailed conceptual design was developed for a 7<sup>th</sup> harmonic multiplier at 19.992 GHz, and a preliminary design made for an 8<sup>th</sup> harmonic multiplier at 22.848 GHz. It seems that three output cavities covering the range between 20 and 25.7 GHz could all be designed and driven using the S-band driver system. In addition, as shall be described below, a 2<sup>nd</sup> harmonic output cavity at 5.712 GHz has also been designed and built for confirming the high predicted conversion efficiency (88%) at this low harmonic, and for installation as part of a two-frequency test stand described elsewhere [11].

Since initiation of this project, another tantalizing application of multi-MW RF sources has emerged, namely to provide a “dense sea” of milli-eV photons in a two-cavity search for hidden sector photons [2]. Yale Physics Professor O. Keith Baker suggested use of power from the Yale/Omega-P magnicon (34.3 GHz, equivalent to 0.142 meV photons) in a microwave experiment that would correspond to the “light shining through a wall” (usually) optical setup. Discovery of such particles would be considered by particle physicists to provide explanations for the existence of dark energy and dark matter. Currently, Baker and his colleagues Dr. Penny Slocum, Dr. Andrew Martin, and graduate student Ms. Ana Malagon are conducting related experiments to search for 0.142 meV photon-coupled chameleons and axions in collaboration with Yale Beam Lab and Omega-P physicists, using facilities at the Yale Beam Physics Lab. The possibility that other sources of multi-MW power at other frequencies could be available in the future has elicited their interest in extending the search. It is noted that 20.0 GHz is equivalent to photons of 0.0826 meV energy. This is the first use directly by elementary-particle physicists of high-power microwave facilities developed with DoE support for HG R&D in a (non-accelerator) experimental search for new hidden sector particles.

### **III. TECHNICAL APPROACH**

Harmonic multipliers have long been used to provide RF power at frequencies where stand-alone sources are unavailable. For HG R&D, a harmonic multiplier has the attraction of providing highly phase-stable power when driven by a lower-frequency amplifier that is itself highly phase-stable, for example a high-power X- or S-band klystron already developed for accelerator applications. Further attractions are that a harmonic multiplier would be a two-cavity device, and thus much simpler than a seven-cavity magnicon, klystron or gyrokystron. The required magnetic field would be resonant at the drive frequency—rather than at the harmonic—and thus can be produced using a conventional (non-superconducting) solenoid system. The electron gun could be a copy of one already developed for klystrons. A disadvantage of a

*Omega-P, Inc.*

Final Report on DoE SBIR Phase I Grant DE-FG02-07ER84854

Topic 32b: Radio Frequency Power for Linear Accelerators

**MULTI-MW 22.8 GHz HARMONIC MULTIPLIER –  
RF POWER SOURCE FOR HIGH-GRADIENT ACCELERATOR R&D**

harmonic multiplier is that its output frequency is limited to be an integer multiple of the drive amplifier's frequency. But for basic HG R&D studies aimed towards achievement of high acceleration gradient, the precise frequency is probably only of minor importance, especially since no other suitable source is currently under development between 17.1 and 30.0 GHz. Another disadvantage of a harmonic multiplier is that a full-power RF driver and two modulators are required; this is the key trade-off that can be weighed against the considerable virtues of a harmonic multiplier as a stand-alone test source for high-gradient HG R&D. However, it should be stressed that, for the source that being built at the Yale Beam Physics Lab, the S-band klystron and both modulators are currently available and under-utilized.

In the Phase I proposal, technical objectives were spelled out for development of a 22.8 GHz second-harmonic frequency multiplier based on the then-stated availability of facilities at SLAC, including a 50-MW X-band klystron and two high-power modulators. With shifting priorities in technology R&D for high energy physics at SLAC and elsewhere, these facilities were no longer committed to the frequency multiplier project. Fortunately, facilities at the Yale Beam Physics Lab were made available, albeit in a different parameter range than those at SLAC. Still, as will be made evident in this and the following section of this report, useful multi-MW output power in K-band (18-26.5 GHz) can be obtained at high-harmonics of 2.856 GHz, using drive power available from an XK-5 former SLAC klystron. Accordingly, the objectives shifted to development of designs for 7<sup>th</sup>, 8<sup>th</sup>, and possibly 9<sup>th</sup> harmonic multipliers, based on use of RF drive power at 2.856 GHz. This work involved simulation studies of beam optics, magnetic field system, input and output cavities, and an output coupler. The case was made, by the completion of Phase I, that a reasonable path was available for demonstration of at least one of the K-band designs with an output in the range of 5 MW—a power level that is acknowledged to be sufficient for many basic experiments in developing new structures for a future high-gradient accelerator. As evidence presented below shows, such a case has indeed been made: feasibility is clearly demonstrated for the proposed RF source.

**Seventh harmonic frequency multiplier driven at S-band**

In this section, simulations are shown for a 7<sup>th</sup> harmonic multiplier. Results described below predict that the device will operate with the following parameters:

drive frequency:	2.856 GHz
output frequency:	19.992 GHz
drive power:	8.5-10 MW
output power:	4.0 – 4.7 MW
RF conversion efficiency:	47%
beam power:	5 MW
beam voltage:	250 kV
beam current:	20 A
operating mode, drive cavity	TE <sub>111</sub>
operating mode, output cavity	TE <sub>711</sub>

**Omega-P, Inc.**

Final Report on DoE SBIR Phase I Grant DE-FG02-07ER84854

Topic 32b: Radio Frequency Power for Linear Accelerators

**MULTI-MW 22.8 GHz HARMONIC MULTIPLIER –  
RF POWER SOURCE FOR HIGH-GRADIENT ACCELERATOR R&D**

An outline drawing of the harmonic multiplier is shown in Fig. 1. It comprises a 100 kV, 1.0 microperv diode gun, followed by a 200 kV post-accelerator gap; a doublet magnetic lens; a rotating-mode TE<sub>111</sub> cavity driven at 2.856 GHz; a beam drift tube; a rotating-mode TE<sub>n11</sub> cavity operating at  $n \times 2.856$  GHz ( $n$  is the harmonic index); an output coupler; and a beam collector. A magnetic field system, with coils at room temperature and a surrounding iron yoke and pole pieces, provides the required  $\sim 2$  kG magnetic field. Elements of the design are discussed below.

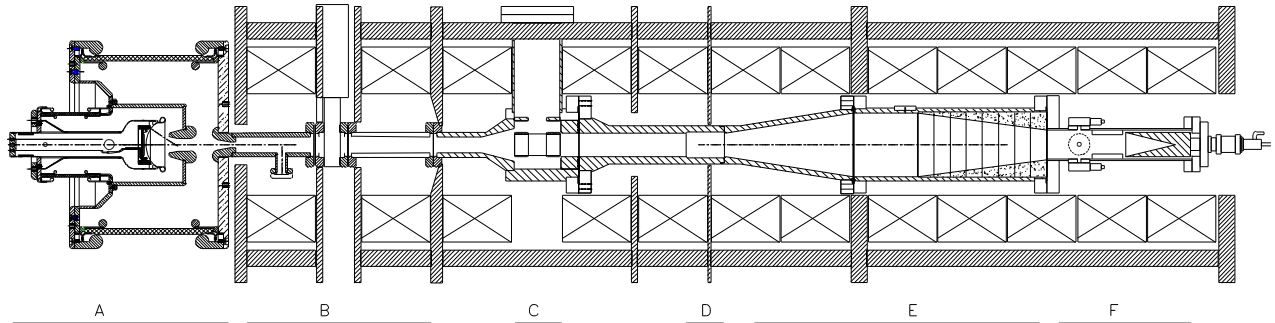

Fig. 1. Drawing of the harmonic multiplier showing (A) electron gun, (B) lens doublet matching system, (C) the input coupler and TE<sub>111</sub> cavity, (D) TE<sub>711</sub> cavity, (E) extraction section, and (F) beam dump. Also shown is the magnetic system of solenoid coils, flux cage and pole pieces. The output coupler, not shown in this drawing, is described below.

**The electron gun** available for tests during Phase II is a 100 kV, perveance  $1 \times 10^{-6}$  A–V<sup>-3/2</sup> Pierce diode gun with a 200 kV post-acceleration stage. The ratio of the cathode voltage to the intermediate anode voltage can be varied  $\sim 10\%$  by mechanical adjustment of an external parallel capacitance, to allow flexibility in the voltage/current characteristics of the beam (i.e. the beam current is not entirely determined by the terminal voltage). For this application, the gun operating parameters are:

beam power	5 MW
beam voltage	250 kV
beam current	20 A
beam perveance	$0.16 \times 10^{-6}$ A–V <sup>-3/2</sup>
cathode diameter	50.8 mm
beam diameter in the drive section	2.5 mm
beam transverse area compression ratio	400:1

An outline drawing of the gun electrodes and simulated beam trajectories are shown in Fig. 2.

*Omega-P, Inc.*

Final Report on DoE SBIR Phase I Grant DE-FG02-07ER84854

Topic 32b: Radio Frequency Power for Linear Accelerators

**MULTI-MW 22.8 GHz HARMONIC MULTIPLIER –  
RF POWER SOURCE FOR HIGH-GRADIENT ACCELERATOR R&D**

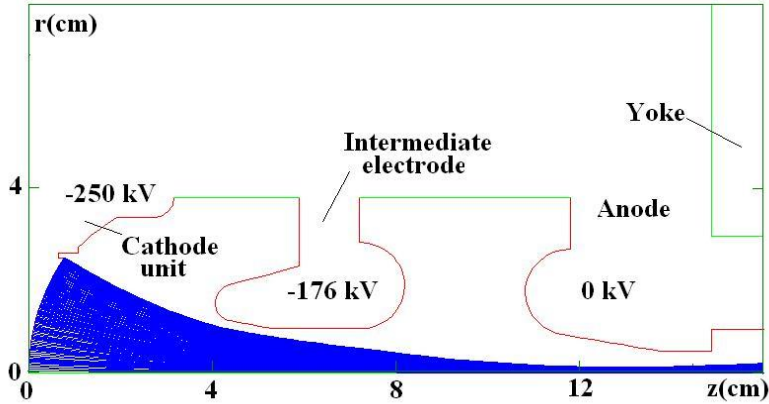

Fig. 2 Gun layout and simulated beam trajectories.

**The magnetic system** consists of a series of solenoid coils and pole pieces to provide the magnetic field, as shown in Fig. 3. After the beam exits the gun it first passes through a lens doublet to match the electron beam into the first cavity. A two coil system is used to generate the 1450-2050 Gauss field with the proper gradient along the beam path to provide phase synchronism between the beam and the RF. Limitations due to the presence of the input couplers cause the magnetic field to peak after the cavity at 2610 G. This results in the need for an additional pole piece between the two cavities as well as an extended beam tunnel in order to reduce the field as needed in the output cavity. The magnetic field requirements in the output cavity to match the synchronism conditions for the  $TE_{711}$  mode require a field decreasing from 2230 to 1840 Gauss. A mid-cavity pole piece is required to provide the necessary gradient.

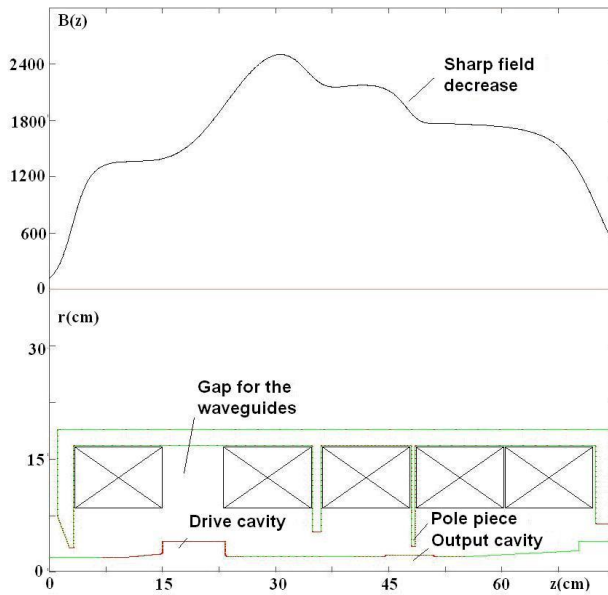

Fig. 3. Magnetic system layout (lower figure) and longitudinal magnetic field profile.

**MULTI-MW 22.8 GHz HARMONIC MULTIPLIER –  
RF POWER SOURCE FOR HIGH-GRADIENT ACCELERATOR R&D**

A zoomed view of the pole piece and output cavity geometry is shown in Fig. 4.

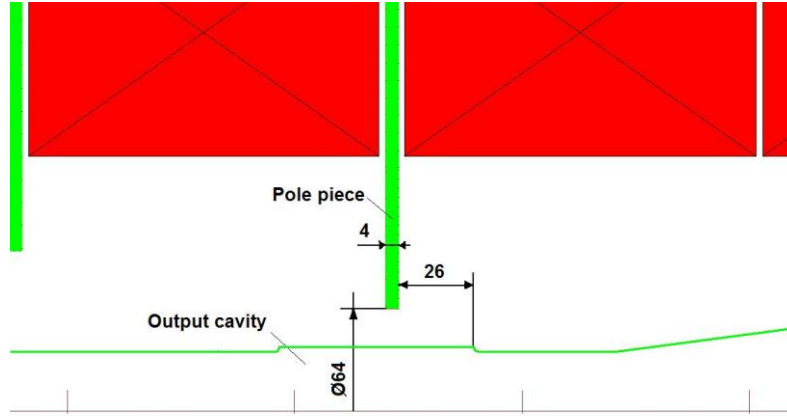

Fig. 4. Output cavity and pole piece needed to provide field gradient.

**Beam matching to the magnetic system** is accomplished using a special external matching coil, shown in Fig. 5. The coil has a diameter of 50 cm to fit around the gun. It requires only 200 Ampere-turns to realize the necessary matching magnetic field.

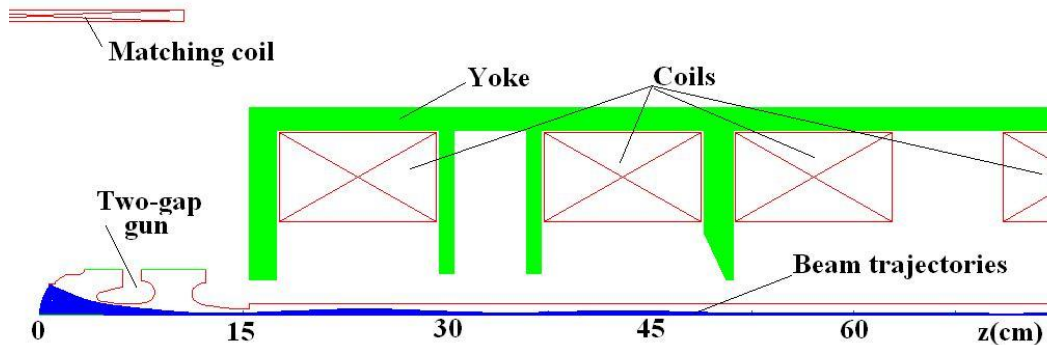

Fig. 5. The gun matching to the magnetic system.

**RF drive power** for the harmonic multiplier is supplied by a SLAC XK-5 klystron originally capable of 21 MW at 2.856 GHz. The RF power taken for the example presented here is 8.5 MW, a value well within the present capabilities of the klystron. The RF power is split by a 3-dB hybrid with a variable phase shifter in one arm and sent to the two port, 90° input coupler on the drive cavity where a rotating TE<sub>111</sub> mode is launched. The cavity has a diameter of 76.2 mm and a length of 77 mm. Irises on the waveguide inputs, along with the beam input and output irises, are adjusted to give a loaded  $Q$  of approximately 150. A drawing of the idealized geometry for the input cavity is shown in Fig. 6.



*Omega-P, Inc.*  
 Final Report on DoE SBIR Phase I Grant DE-FG02-07ER84854  
 Topic 32b: Radio Frequency Power for Linear Accelerators  
**MULTI-MW 22.8 GHz HARMONIC MULTIPLIER –  
 RF POWER SOURCE FOR HIGH-GRADIENT ACCELERATOR R&D**

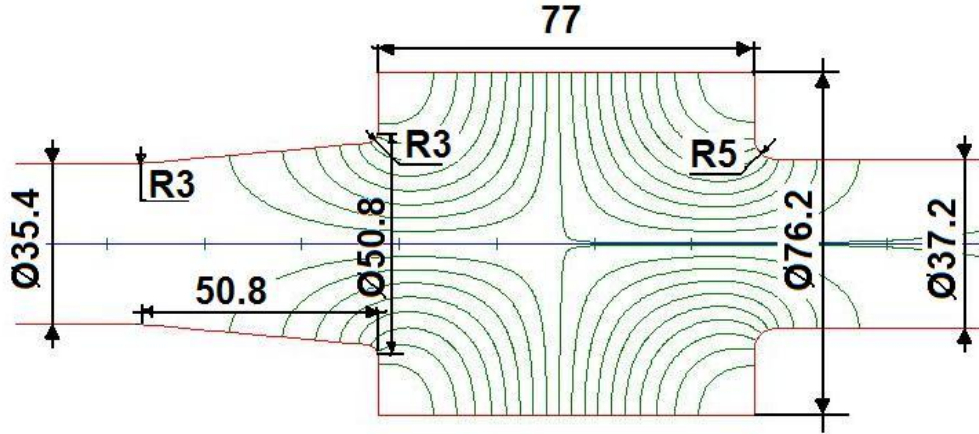

Fig. 6. Idealized layout for the drive cavity. The field map is also shown.

The drive cavity is designed to have the following parameters:

operating frequency	2.856 GHz
operating mode	rotating TE <sub>111</sub>
loaded $Q$	~150
maximum electric field	58 kV/cm.

The rotating TE<sub>111</sub> wave is excited by two standard input waveguides displaced azimuthally 90° with respect to one another. The cavity has also two compensating protrusions in order to symmetrize the field. A SolidWorks image of the cavity is shown in Fig. 7, dimensions are given in Fig. 8, and maps of the electric field distribution are shown in Fig. 9.

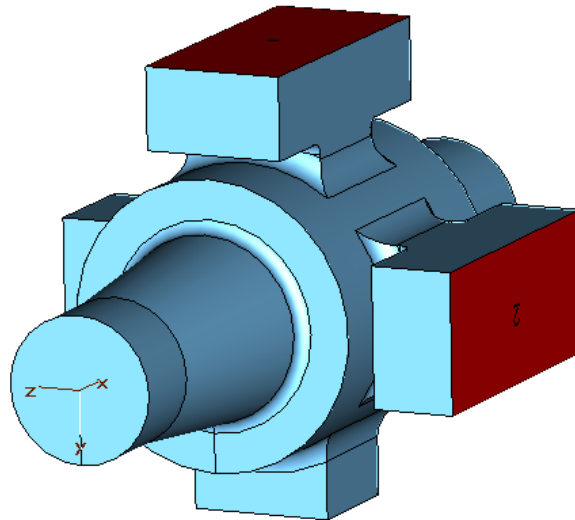

Fig. 7. 3-D cavity model of the input cavity that includes the two input ports (WR284) and two compensating stub protrusions.

**Omega-P, Inc.**  
 Final Report on DoE SBIR Phase I Grant DE-FG02-07ER84854  
 Topic 32b: Radio Frequency Power for Linear Accelerators  
**MULTI-MW 22.8 GHz HARMONIC MULTIPLIER –  
 RF POWER SOURCE FOR HIGH-GRADIENT ACCELERATOR R&D**

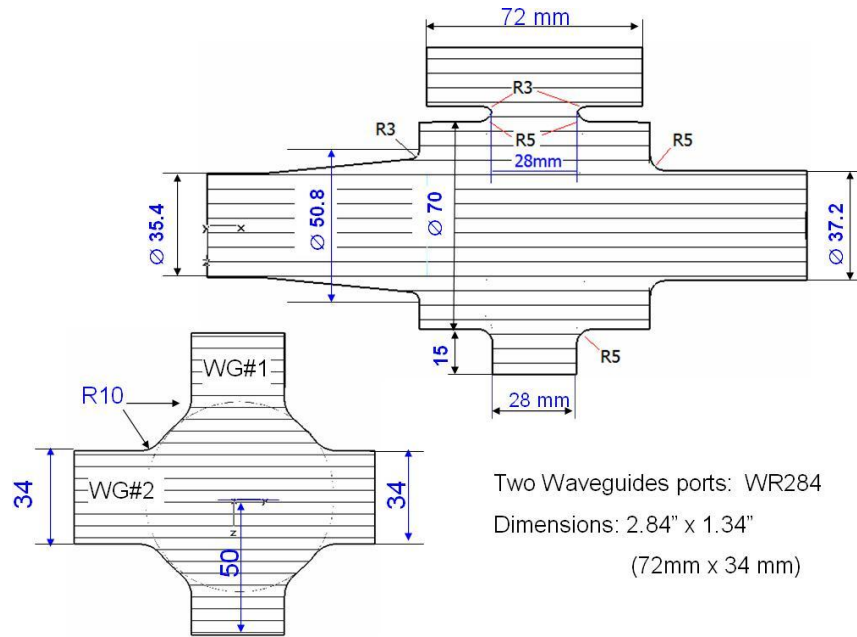

Fig. 8. Cavity dimensions including the waveguides and stub protrusions.

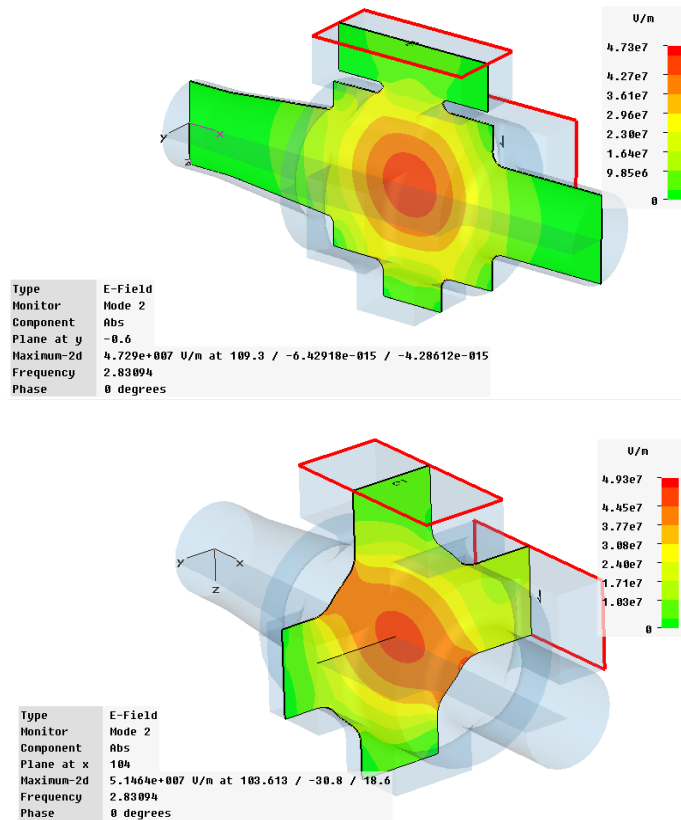

Fig. 9. Electric field profiles inside the cavity on two orthogonal cut planes for the TE<sub>111</sub> mode.

**Omega-P, Inc.**

Final Report on DoE SBIR Phase I Grant DE-FG02-07ER84854

Topic 32b: Radio Frequency Power for Linear Accelerators

**MULTI-MW 22.8 GHz HARMONIC MULTIPLIER –  
RF POWER SOURCE FOR HIGH-GRADIENT ACCELERATOR R&D**

For the two orthogonal TE<sub>111</sub> modes, almost identical parameters were found, using a mesh in the simulations with ~500,000 elements, namely

mode #1: freq = 2.84263 GHz;  $Q_{\text{ext}} = 155$   
mode #2: freq = 2.84181 GHz;  $Q_{\text{ext}} = 142$ .

The XK-5 klystron and 300 kV - 31 A modulator, the WR-284 evacuated transmission line with variable phase and amplitude splitting of output power, the electron gun, and coils with power supplies for the magnetic system are installed and operating at the Yale Beam Physics Lab.

**The output cavity** is operated in the TE<sub>711</sub> mode at 19.992 GHz, the 7<sup>th</sup> harmonic of the drive frequency. This cavity has a 41.2 mm diameter and a length of 60 mm. The required loaded  $Q$  is approximately 900. Generated 19.992 GHz RF power is here extracted axially through an output iris into an up-tapered section to de-couple the beam from the RF and stop the interaction. The RF can then be sampled by a wall probe to measure its frequency and power, and finally dissipated on a RF absorber to prevent reflections back into the output cavity. Once operation of the two-cavity system is confirmed in this manner, an output cavity with an integral output coupler will be installed; a description of the output coupler is provided in the next section. The idealized output cavity layout is shown in Fig. 10.

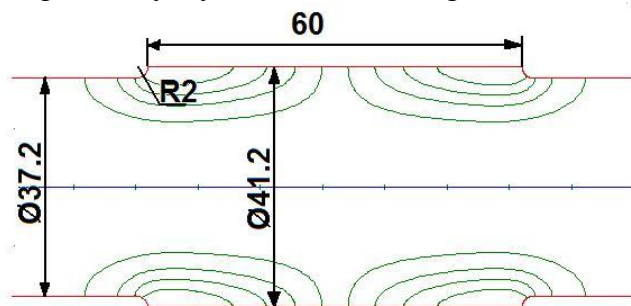

Fig. 10. Layout for the idealized output cavity. Dimensions are in mm.

The output cavity should have the following parameters:

operating frequency	$7 \times 2.856 = 19.992$ GHz
operating mode	rotating TE <sub>711</sub>
loaded $Q$	900
maximum electric field	175 kV/cm.

In order to achieve synchronism, the magnetic field near the output cavity should have a sharp decrease (see Fig. 3). This field distribution is achieved by use of a special pole piece, also seen in Fig 3, which will be integrated into the construction of the cavity to insure precision. The magnetic circuit does not allow much room for the output waveguide upstream of the pole piece (i.e., towards the gun), so the coupler will be downstream. The necessary loaded  $Q$  is relatively high, namely 900. Results of a simulation study for 7<sup>th</sup> harmonic output, using beam, cavity, and magnetic circuit parameters discussed above, are shown in Fig. 11. Here energies (in blue) and

*Omega-P, Inc.*

Final Report on DoE SBIR Phase I Grant DE-FG02-07ER84854

Topic 32b: Radio Frequency Power for Linear Accelerators

**MULTI-MW 22.8 GHz HARMONIC MULTIPLIER –  
RF POWER SOURCE FOR HIGH-GRADIENT ACCELERATOR R&D**

the magnitudes of radial orbit displacements (in red) are shown for a representative set of particles. It is from this simulation that the output parameters listed on p. 4 are derived.

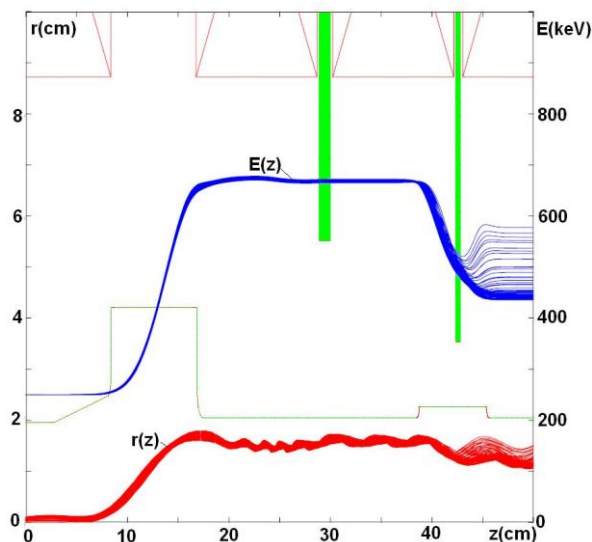

Fig. 11. Beam particle energies (upper curves) and radial excursions (lower curves) for  $n = 7$  (frequency quadrupler), with the  $TE_{711}$  mode output cavity tuned to 19.992 GHz. Cavity outlines are also shown.

A similar simulation study for an 8<sup>th</sup> harmonic multiplier has also been carried out. Results are summarized in the table below, and energy and trajectory plots are shown in Fig. 12. Input cavities are identical for the 7<sup>th</sup> and 8<sup>th</sup> harmonic simulations. The close similarities between the magnetic circuit and output cavity dimensions and placement enforce the claim made above that a demountable system could be built with interchangeable output structures, without need for changes in the balance of the device, except for minor changes in the magnetic field profile. Parameters for the 8<sup>th</sup> harmonic multiplier are:

drive frequency	2.856 GHz
output frequency	22.848 GHz
drive power	8.5-10 MW
output power	3.8-4.5 MW
harmonic conversion efficiency	45%
beam power	5 MW
beam voltage	250 kV
beam current	20 A
operating mode, drive cavity	$TE_{111}$
operating mode, output cavity	$TE_{811}$

**MULTI-MW 22.8 GHz HARMONIC MULTIPLIER –  
RF POWER SOURCE FOR HIGH-GRADIENT ACCELERATOR R&D**

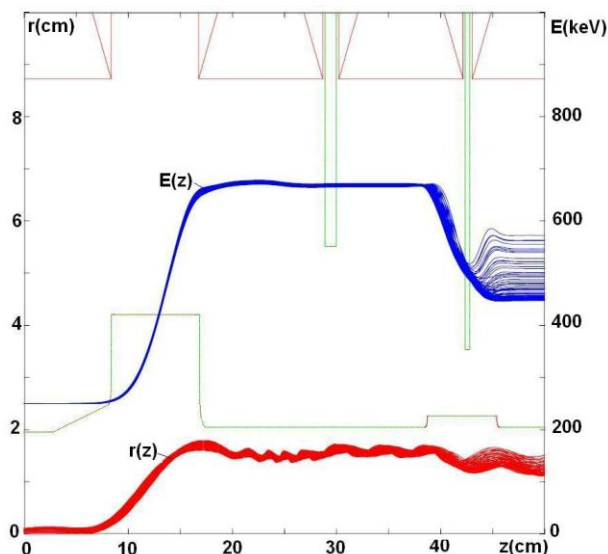

Fig. 12. Same as Fig. 11, but here for 8<sup>th</sup> harmonic at 22.848 GHz.

**Output coupler.** Both electric and magnetic fields of the operating mode in the output cavity are concentrated near the outer cylindrical surface. The operating mode is trapped in the cavity because the beam pipe has a cut-off frequency for this mode that is higher than the operating frequency. All other modes with lower azimuthal variation are radiated into the beam-pipe. RF power excited in the cavity by a rotating electron beam can be extracted through coupling slots to an external waveguide. At least two waveguides are necessary to load both polarizations. Unfortunately, a scheme with two waveguides is not effective for modes with a high azimuthal index. The main reason is that perturbations due to the coupling slots break the symmetry of the fields and the operating mode becomes coupled to modes with lower azimuthal index. This problem was encountered in devices like the C-band gyrocon frequency multiplier [2-5]. The best solution which was proposed to solve this problem was to use many coupling slots to a surrounding waveguide, as shown in Fig. 13. The rectangular waveguide runs around the entire cavity perimeter. The cut-off frequency of the feeder (waveguide width) is chosen such that the phase velocities of the waves in both the waveguide and the cavity are identical at the operating frequency. Coupling to the cavity is made through many small coupling holes in the wall between the cavity and the waveguide.

This configuration for coupling was successfully tested in high frequency RF pulse compressors [6-8], and proposed at CERN for a new MBK design concept [9]. Both of these

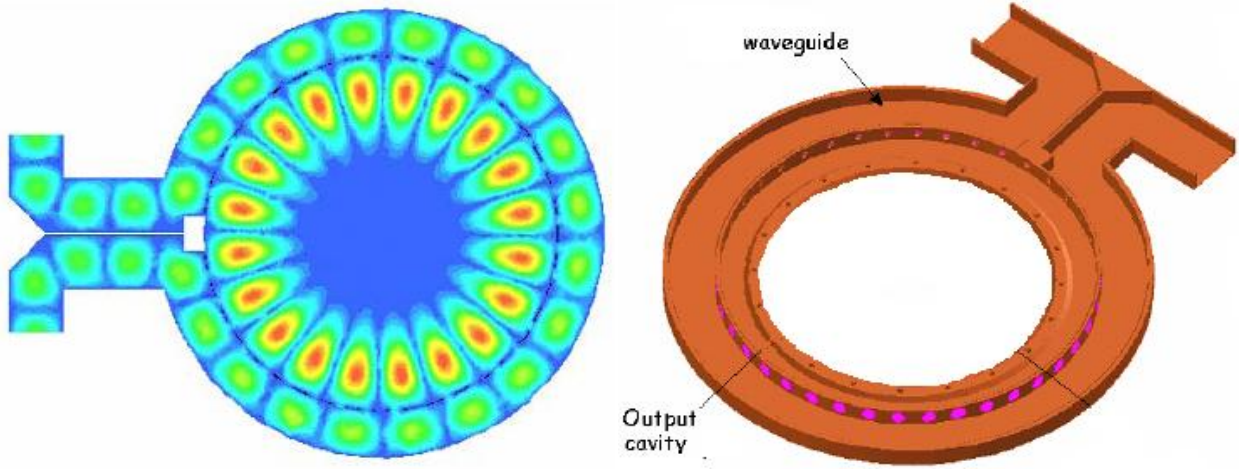

Fig. 13. Illustration of coupling between a cavity and an external wrap-around waveguide.

devices are based on results and experience obtained from the use of so-called Barrel-Open-Cavity (BOC) technology, which was initially developed in Russia but which has been developed further over the last few years at CERN. It is a well-established fact that in the BOC which is used for high frequency RF pulse compressors, the mode spectrum of  $TM_{m,n,q}$  modes with large  $m$  (“whispering gallery” modes) can easily be made extremely sparse. All modes in the BOC with low-azimuthal index or high-radial and high-axial indices radiate efficiently through the open cavity faces, while the whispering gallery modes remain unaffected. In all these devices the coupling to the output cavities was done in a similar way. In a pulse compressor, the best matching to the cavity is obtained when the distance between coupling holes is equal to a quarter of the operating mode wavelength – the total number of holes is therefore  $4 \times m$ . Such a configuration provides a good matching to the cavity and reduces the probability of breakdown: the 3 GHz BOC cavity was processed up to 80 MW without any serious breakdown problems.

**Conceptual design of the 7<sup>th</sup> harmonic output cavity** is now described. A rotating  $TE_{711}$  mode in the output cavity is coupled through the series of coupling slots with the output waveguide. To organize a travelling wave in the waveguide the phase velocity and position of coupling slots should fulfilled certain requirements, described below. In the cavity, the amplitude of the rotating mode is given by

$$A(\varphi) = A_0 \cdot e^{i(\omega t - N_{cav} \cdot \varphi)},$$

where  $N_{cav}$  is the cavity azimuthal index (number of azimuthal variations),  $\varphi$  is the azimuthal coordinate (angle), and  $\omega = 2\pi f$  is the angular frequency. Each coupling slot will excite the waveguide with an amplitude:

$$A_w = \alpha \cdot A(\varphi_i),$$

**Omega-P, Inc.**

Final Report on DoE SBIR Phase I Grant DE-FG02-07ER84854

Topic 32b: Radio Frequency Power for Linear Accelerators

**MULTI-MW 22.8 GHz HARMONIC MULTIPLIER –  
RF POWER SOURCE FOR HIGH-GRADIENT ACCELERATOR R&D**

where  $\alpha$  is the coupling between cavity and waveguide,  $N_{slot}$  is the number of slots, and  $\varphi_i = 2\pi \cdot \frac{i}{N_{slot}}$  is the angular position of each slot. In the waveguide we will excite two waves, one traveling in each direction: the direct wave  $D$  (running in the same direction as the rotating mode in the cavity) and the reverse wave  $R$  (opposite directions). The amplitudes of these modes are as follow:

$$D(N_{wg}) = \alpha \cdot A_0 \cdot e^{i(\omega t - N_{wg} \cdot \varphi)} \cdot \sum_{m=1}^{N_{slot}} e^{-i(N_{cav} - N_{wg}) \cdot 2\pi \cdot \frac{m}{N_{slot}}}$$

$$R(N_{wg}) = \alpha \cdot A_0 \cdot e^{i(\omega t + N_{wg} \cdot \varphi)} \cdot \sum_{m=1}^{N_{slot}} e^{-i(N_{cav} + N_{wg}) \cdot 2\pi \cdot \frac{m}{N_{slot}}}$$

Where  $N_{wg}$  is the waveguide azimuthal index. For our cavity with design value  $N_{cav} = 7$ , we can chose different number of coupling slots and different azimuthal indices in the waveguide. Three examples, for  $N_{slot} = 8$ ,  $N_{slot} = 14$  and  $N_{slot} = 28$  are shown in graphs in Figs. 14-16.

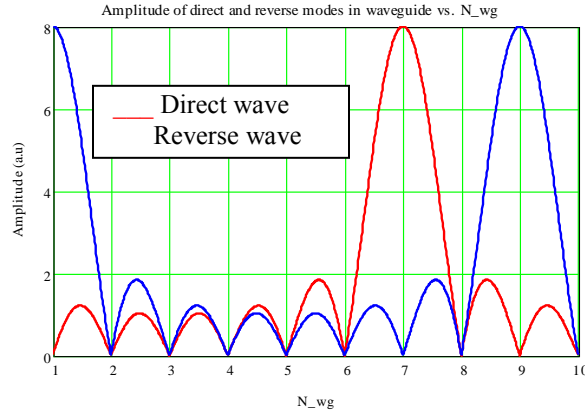

Fig. 14. Amplitudes of Direct and Reverse modes in waveguide vs.  $N_{wg}$ . ( $N_{slot} = 8$ )

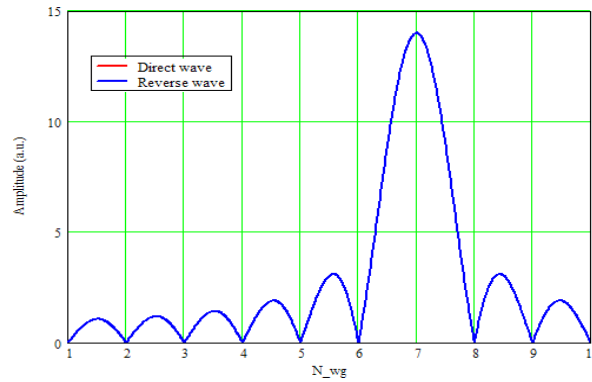

Fig. 15. Amplitudes of Direct and Reverse modes in waveguide vs.  $N_{wg}$ . ( $N_{slot} = 14$ )  
Note that both curves are identical, and thus superimpose upon one another.

**MULTI-MW 22.8 GHz HARMONIC MULTIPLIER –  
RF POWER SOURCE FOR HIGH-GRADIENT ACCELERATOR R&D**

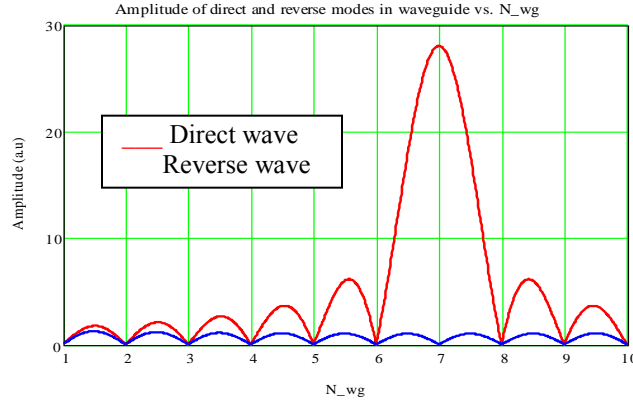

Fig. 16. Amplitudes of Direct and Reverse modes in waveguide vs.  $N_{wg}$ . ( $N_{slot} = 28$ )

As one can see from these plots, for each chosen number of coupling slots, one can pick a waveguide azimuthal index  $N_{wg}$  where the rotating operating mode in the cavity will excite in the waveguide only a direct wave ( $N_{wg} = 7$  for  $N_{slot} = 8$ , or  $N_{slot} = 28$ ), or only a reverse mode ( $N_{wg} = 9$  for  $N_{slot} = 8$ , see Fig. 14), or both waves with the same amplitude ( $N_{wg} = 7$  for  $N_{slot} = 14$ ). Table I shows all possible configurations. In all cases, independently of the number of slots, the cavity will excite direct waves in the waveguide if  $N_{cav} = N_{wg} = 7$ . The last two columns show how the D:R ratio will change if one or two slots are not coupled to the waveguide. This will occur when the waveguide is diverted away from the cavity to the external load. In our design the number of wavelengths in waveguide is limited  $N_{wg} \approx 2\pi R/\lambda_0 < 10$ , where  $R \sim 25$  mm is the average radius of the waveguide, and  $\lambda_0 = c/f \sim 15$  mm at 20 GHz.

**Table I. Waveguide azimuthal index for different numbers of coupling slots**

Number of coupling slots	$N_{wg}$ When $D(N_{wg}) = \max$		$N_{wg}$ when $R(N_{wg}) = \max$		One slot is missing	Two slots are missing
		Ratio D:R		Ratio D:R		
5	2, 7	5:0	3, 8	0:5	1:4	2:1
6	1, 7	6:0	5	0:6	1:5	4:1
7	7	7:7	7	7:7		
8	7	8:0	9	0:8	1 : 7	6 : 1.4
9	7	9:0	2	0:9	1 : 8	0.35 : 7
10	7	10:0	3	0:10	1 : 9	0.62 : 8
11	7	11:0	4	0:11	1 : 10	1.31 : 9
12	7	12:0	5	0:12	1 : 11	1.73 : 10
13	7	13:0	6	0:13	1 : 12	1.94 : 11
14	7	14:14	7	14:14		
15	7	15:0	8	0:15	1: 14	1.96 : 13
16	7	16:0	9	0:16	15:1	1.85: 14
21	7	21:0				
28	7	28:0				0 : 26



***Omega-P, Inc.***

Final Report on DoE SBIR Phase I Grant DE-FG02-07ER84854

Topic 32b: Radio Frequency Power for Linear Accelerators

**MULTI-MW 22.8 GHz HARMONIC MULTIPLIER –  
RF POWER SOURCE FOR HIGH-GRADIENT ACCELERATOR R&D**

From this table a few attractive configurations can be identified for further design studies:

1.  $N_{slot} = 8$ ;  $N_{wg} = 9$ . Reverse wave in waveguide only
  - Advantages
    - i. Small number of coupling slots, easy for production
    - ii. Waveguide width is pretty large
  - Disadvantages
    - i. Perturbation of field symmetry and possible transformation operating mode to mode with lower azimuthal index → radiation thru beam pipe
2.  $N_{slot} = 14$ ;  $N_{wg} = 7$ . Both Direct and Reverse wave in waveguide.
  - Advantages
    - i. High field symmetry (2x7). Small risk of mode transformation
  - Disadvantages
    - i. Missing 1 or 2 slots will change directivity
3.  $N_{slot} = 28$ ;  $N_{wg} = 7$ . Direct wave in waveguide only
  - Advantages
    - i. High field symmetry (4x7). Small risk of mode transformation
    - ii. Missing 2xn coupling slots not affect to directivity
    - iii. Low fields in each coupling slot
  - Disadvantages
    - i. Needs many slots

**Waveguide dimensions** can be fixed once the above indices are selected. A general view of the cavity (half-geometry cut through waveguide) is shown in Fig. 17.

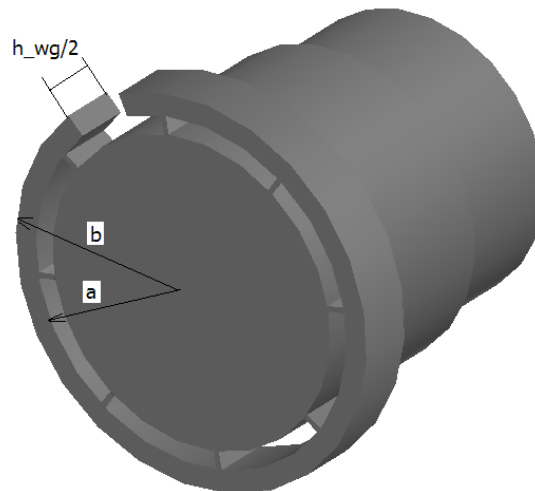

Fig. 17. Cavity, with the surrounding waveguide, as used in the simulation model.

For chosen radial dimensions of the waveguide **a** and **b**, the waveguide width is determined by

**Omega-P, Inc.**

Final Report on DoE SBIR Phase I Grant DE-FG02-07ER84854

Topic 32b: Radio Frequency Power for Linear Accelerators

**MULTI-MW 22.8 GHz HARMONIC MULTIPLIER –  
RF POWER SOURCE FOR HIGH-GRADIENT ACCELERATOR R&D**

$$h_{wg} = \frac{\lambda_0 / 2}{\sqrt{1 - (\lambda_0 / \lambda_c)^2}},$$

where  $\lambda_0 = c/f$  is the free space wavelength,  $\lambda_c$  is the critical wavelength in coaxial waveguide, which is determined from the equation (boundary conditions for electric field):

$$J'_k\left(\frac{2\pi \cdot a}{\lambda_c}\right) \cdot Y'_k\left(\frac{2\pi \cdot b}{\lambda_c}\right) - J'_k\left(\frac{2\pi \cdot b}{\lambda_c}\right) \cdot Y'_k\left(\frac{2\pi \cdot a}{\lambda_c}\right) = 0,$$

with  $k$  the azimuthal index. The calculated waveguide width as a function of outer waveguide radius  $b$  for two different values of internal radius  $a = 22$  mm and  $a = 23$  mm is shown in Fig. 18, for different azimuthal indexes ( $N_{wg}=7,8,9,10$ ). For waveguide widths  $a = 23$  mm,  $b = 28$  mm and 26 mm, the resulting waveguide widths are shown in the following table.

Azimuthal index $k$	WG width (mm) $b = 28$ mm	WG width (mm) $b = 26$ mm
5	8.485	8.584
6	9.069	9.256
7	9.934	10.262
8	11.327	12.016
9	13.887	15.787
10	21.246	33.376

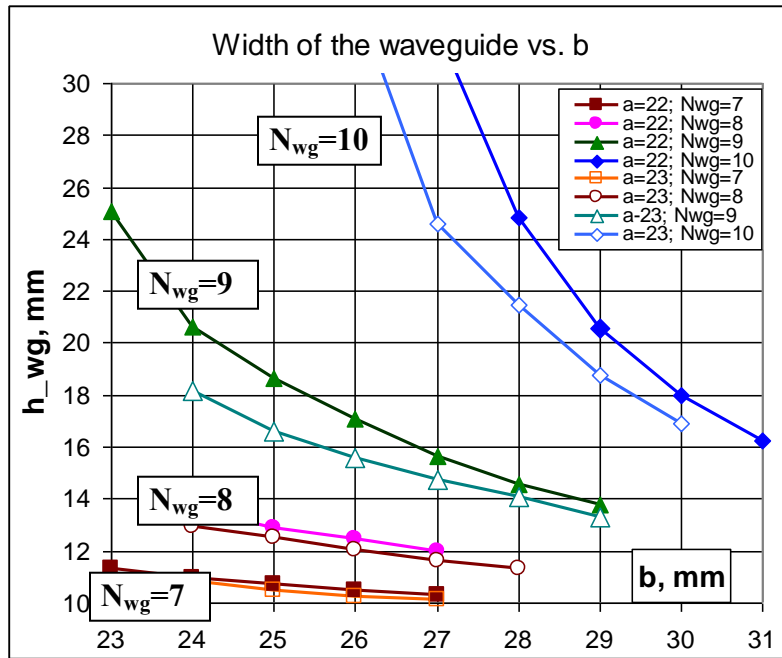
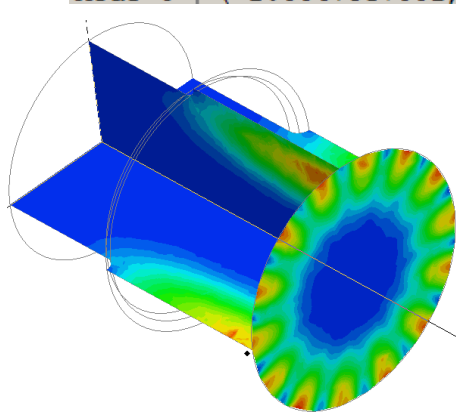

Fig. 18. Waveguide width vs. waveguide outer radius.

**MULTI-MW 22.8 GHz HARMONIC MULTIPLIER –  
RF POWER SOURCE FOR HIGH-GRADIENT ACCELERATOR R&D**

**RF simulations of the cavity without the waveguide** were first carried out, to circumscribe the range of parameters for later analysis. Cavity modes in the vicinity of the operating mode was simulated by HFSS for the idealized geometry shown in Fig. 10. In simulations we are using only half-geometry with the magnetic boundary conditions at the plane of symmetry. At the beam-pipe end electric boundary conditions were applied. In Fig. 19 the results of simulation for first 10 modes are presented (electric field distribution in three cut-planes). Only the first two modes are operating modes (two polarization), other modes are not trapped in the cavity and will be radiated through the beam-pipe.

	Frequency (GHz)
Mode 1	( 1.99908e+001,
Mode 2	( 1.99940e+001,
Mode 3	( 2.00186e+001,
Mode 4	( 2.00200e+001,
Mode 5	( 2.00459e+001,
Mode 6	( 2.00475e+001,
Mode 7	( 2.01351e+001,
Mode 8	( 2.01389e+001,
Mode 9	( 2.02507e+001,
Mode 10	( 2.02524e+001,



mode #1

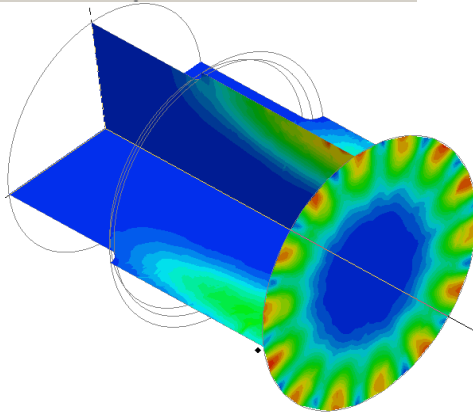

mode #2

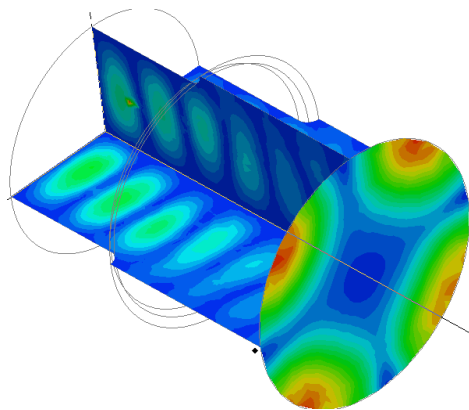

mode #3

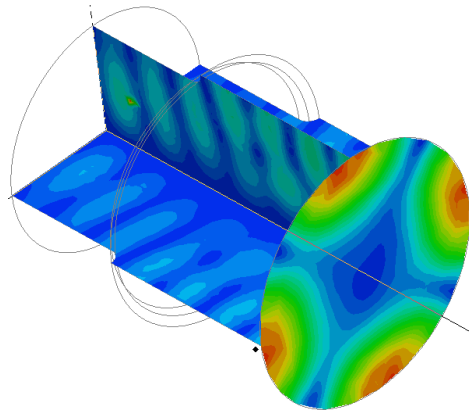

mode #4

*Omega-P, Inc.*  
Final Report on DoE SBIR Phase I Grant DE-FG02-07ER84854  
Topic 32b: Radio Frequency Power for Linear Accelerators  
**MULTI-MW 22.8 GHz HARMONIC MULTIPLIER –  
RF POWER SOURCE FOR HIGH-GRADIENT ACCELERATOR R&D**

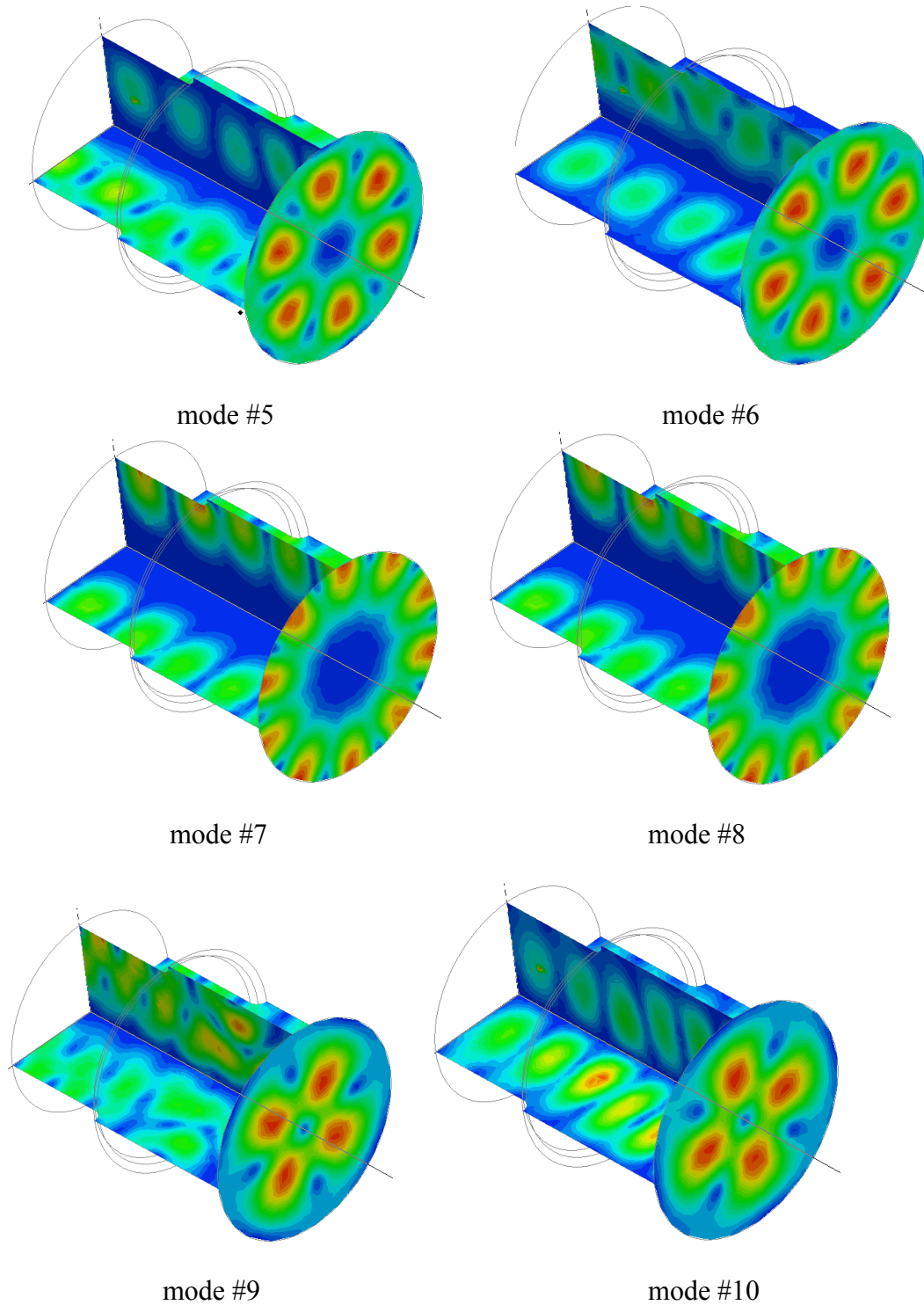
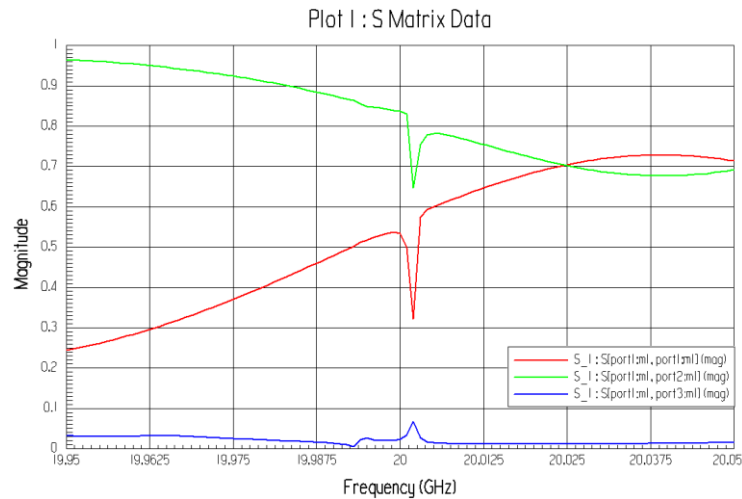

Fig. 19. Electric field patterns for a few modes in vicinity of the operating modes (#1 and #2). Note that all other modes (#3 - #10) are not trapped, and radiate into the beam pipe.

**Cavity coupled to the waveguide** has also been simulated, with the example presented here having waveguide dimensions and field indices:  $a = 23$  mm,  $b = 25$  mm,  $h_{wg} = 13.887$  mm,  $N_{cav} = 7$ ,  $N_{slot} = 8$ ,  $N_{wg} = 9$ . This case is for the reverse traveling wave regime. The cavity was simulated by HFSS (again half-geometry with magnetic boundaries at the plane of symmetry). The waveguide has two ports. The beam-pipe end was also assigned as multi-mode port. Result of simulation S-parameters for small coupling slots (angular width =  $2^\circ$ ) are shown in Fig. 20. The electric field pattern for the operating mode is shown in Fig. 21. This example exhibits a small positive frequency pulling and a larger  $Q$  value than is desired. Further studies to refine this design were carried out, including variations in the slot angular width and the slot thickness; cavity dimensions are also be revised slightly to offset the frequency pulling. Nevertheless, these results confirm the validity of the proposed coupling scheme, and point the way towards detailed refinements that are carried out during the device's engineering design.



ig. 20: S-parameter plot in vicinity of operating mode.

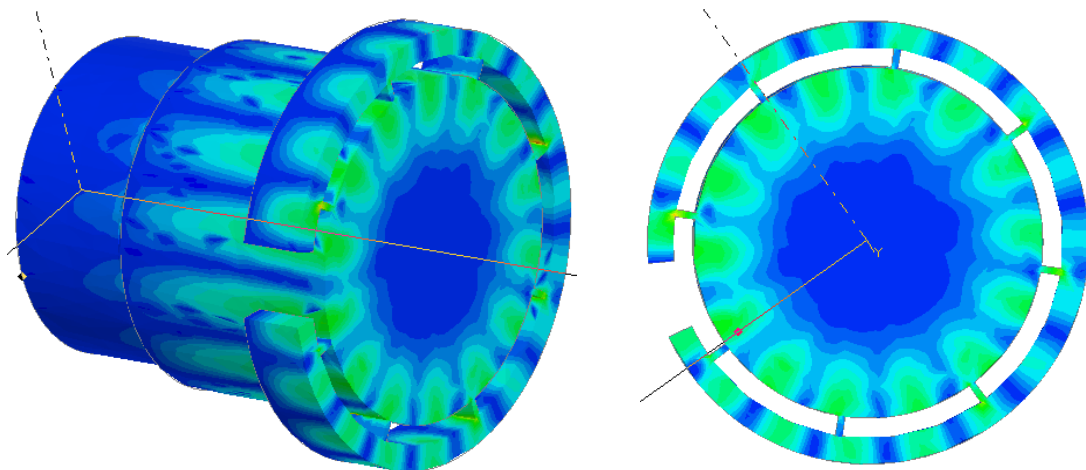

Fig. 21. Electric field pattern in cavity and waveguide ( $N_{cav} = 7$ ,  $N_{slot} = 8$ ,  $N_{wg} = 9$ ).

*Omega-P, Inc.*

Final Report on DoE SBIR Phase I Grant DE-FG02-07ER84854

Topic 32b: Radio Frequency Power for Linear Accelerators

**MULTI-MW 22.8 GHz HARMONIC MULTIPLIER –  
RF POWER SOURCE FOR HIGH-GRADIENT ACCELERATOR R&D**

**IV. STATUS OF HARDWARE DEVELOPMENT**

On the basis of design, analysis, and simulations described above, hardware items for incorporation into 7<sup>th</sup> and 2<sup>nd</sup> harmonic multipliers have been assembled and tested at 19.992 and 5.712 GHz. As stated above, the 2<sup>nd</sup> harmonic device is being built (a) to confirm the predicted exceptionally high (88%) RF-to-RF conversion efficiency for this two-cavity interaction; and (b) to be available together with fundamental power at 2.856 GHz to constitute a two-frequency multi-MW phase coherent test stand with variable amplitudes and phases for both frequencies—for tests of RF breakdown rates in two-frequency cavities [11], and for powering a two-frequency RF gun [12]. In paragraphs that follow, details are provided on these hardware items.

**Modulator.** A 65-MW line-type modulator is available in the Yale Beam Physics Lab to power a former-SLAC XK-5 S-band klystron. Photos of the modulator and control rack are shown in Figure 22, and a brief table of parameters is given in Table II.



Figure 22. Available 65-MW modulator (left), and its control rack (right).

Table II. Gross parameters of the modulator. Output pulse is fed to XK-5 klystron via a 12:1 turns ratio pulse transformer

	<i>type</i>	<i>duration / max. rep. rate</i>	<i>voltage</i>	<i>current</i>
input	DC		21 kV	100 mA
output	pulse	1.5 - 2 micro-sec / 10 Hz	21 kV	3,000 Amps

*Omega-P, Inc.*

Final Report on DoE SBIR Phase I Grant DE-FG02-07ER84854

Topic 32b: Radio Frequency Power for Linear Accelerators

**MULTI-MW 22.8 GHz HARMONIC MULTIPLIER –  
RF POWER SOURCE FOR HIGH-GRADIENT ACCELERATOR R&D**

**Klystron.** A photo of the S-band klystron is shown in Figure 23, and its parameters are listed in Table III.



Figure 23. XK-5 S-band klystron. Modulator for electron gun described  
In the next paragraph is seen at the right-hand side of the photo.

Table III. Parameters of klystron.

model	RCA XK5
type	pulsed
pulse duration, max	1.5 micro-sec
max. rep. rate	modulator dependent
output frequency	2,856 MHz
rated output power	21 MW
currently produced power	17 MW
output waveguide	WR284, one arm

*Omega-P, Inc.*

Final Report on DoE SBIR Phase I Grant DE-FG02-07ER84854

Topic 32b: Radio Frequency Power for Linear Accelerators

**MULTI-MW 22.8 GHz HARMONIC MULTIPLIER –  
RF POWER SOURCE FOR HIGH-GRADIENT ACCELERATOR R&D**

**Electron gun.** A photo of the electron gun in its oil tank is shown in Figure 24, and a list of its parameters is given in Table IV. Figure 25 shows a history of reactivation of the gun to its rated operating perveance, after it had not be operated for over two years, and had been inadvertently exposed to atmosphere.

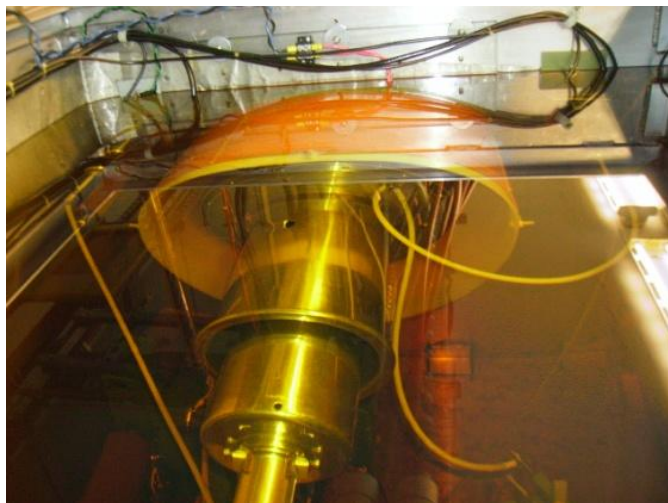

Figure 24. Electron gun, installed in oil tank just adjacent to its modulator shown in Fig. 23.

Table IV. Properties of electron gun.

<i>type</i>	Pierce diode gun w/ intermediate anode to control the perveance, and built-in modulator
<i>cathode</i>	of dispenser type, BaO-based, 50.8mm DIA.
<i>cathode operational temperature</i>	900-1000 °C
<i>gun voltage/ beam energy</i>	0 – 300 kV
<i>beam current</i>	0 - 31 Amps
<i>beam compression ratio</i>	400 : 1
<i>pulse width</i>	1 micro-sec
<i>max. rep. rate</i>	10 Hz



*Omega-P, Inc.*

Final Report on DoE SBIR Phase I Grant DE-FG02-07ER84854

Topic 32b: Radio Frequency Power for Linear Accelerators

**MULTI-MW 22.8 GHz HARMONIC MULTIPLIER –  
RF POWER SOURCE FOR HIGH-GRADIENT ACCELERATOR R&D**

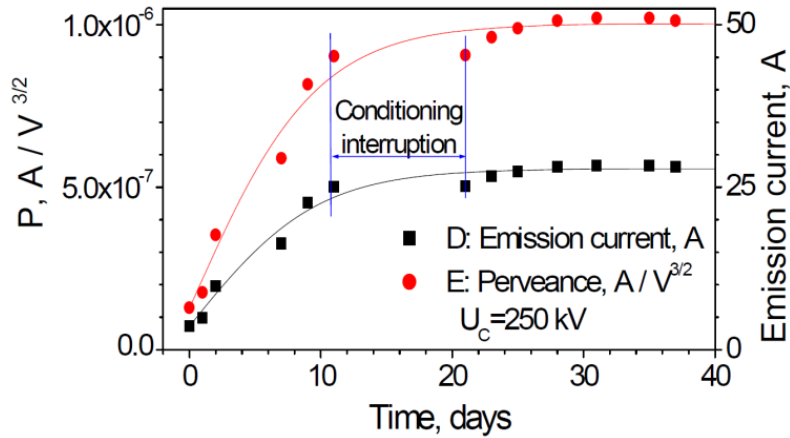

Figure 25. History of reactivation of electron gun to full design perveance at 250 kV.

**Magnet system.** A system of water-cooled coils, pole pieces, and power supplies (one per coil) have been assembled to supply the solenoidal magnetic field for the device. A photo is shown in Figure 26, and a list of parameters is given in Table V.



Figure 26. Solenoid magnet assembled at test, with gun tank seen at left.

Table V. Parameters of magnet system.

<i>type</i>	multi-coil, multi-pole magnetic system to allow one adjust the field profile for optimal interaction
<i>longitudinal field on axis</i>	up to ~2.5 kGs
<i>coil current</i>	up to ~120 Amps
<i>overall length</i>	136 cm

**Omega-P, Inc.**

Final Report on DoE SBIR Phase I Grant DE-FG02-07ER84854

Topic 32b: Radio Frequency Power for Linear Accelerators

**MULTI-MW 22.8 GHz HARMONIC MULTIPLIER –  
RF POWER SOURCE FOR HIGH-GRADIENT ACCELERATOR R&D**

**S-band drive cavity.** The TE<sub>111</sub>-mode S-band drive cavity has been designed, built, tuned, and (at this writing) returned to the vendor for re-brazing a misaligned flange. A design drawing is shown in Figure 27, where the two input waveguides needed to excite the rotating mode—when equal amplitude inputs are applied in phase quadrature. A photo of the cavity being clamped prior to initial cold test is in Figure 28. To improve the match of the input waveguides to the cavity, tuning pins were inserted, as seen in Figure 29. Also seen in the figures are the compensating pockets in the cavity opposite each waveguide input that provide good symmetry for the fields, which would otherwise show a strong quadrupole distortion.

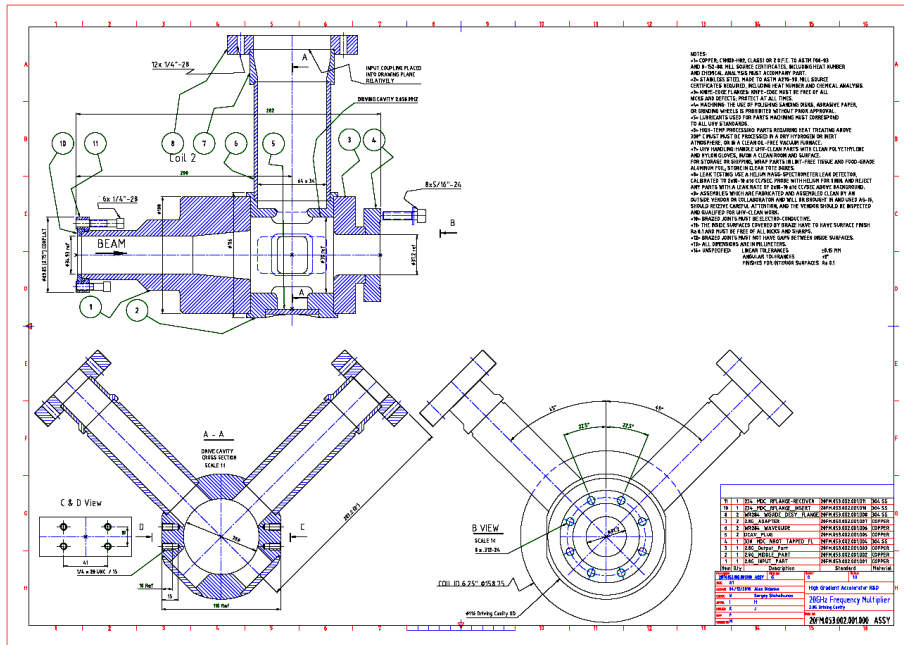

Figure 27. Design drawing for the S-band drive cavity.

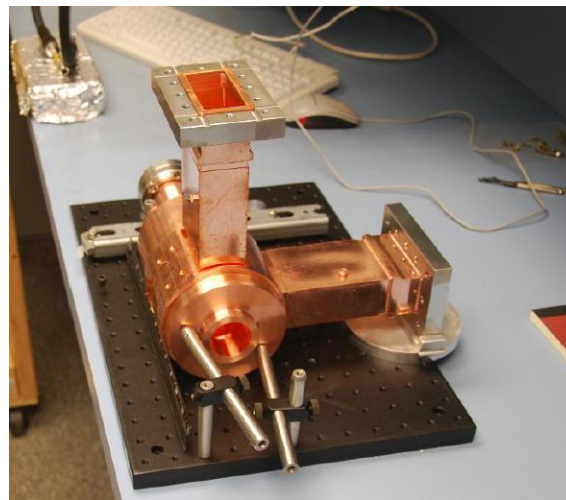

Figure 28. Cavity after clamping for initial cold test.

*Omega-P, Inc.*

Final Report on DoE SBIR Phase I Grant DE-FG02-07ER84854

Topic 32b: Radio Frequency Power for Linear Accelerators

**MULTI-MW 22.8 GHz HARMONIC MULTIPLIER –  
RF POWER SOURCE FOR HIGH-GRADIENT ACCELERATOR R&D**

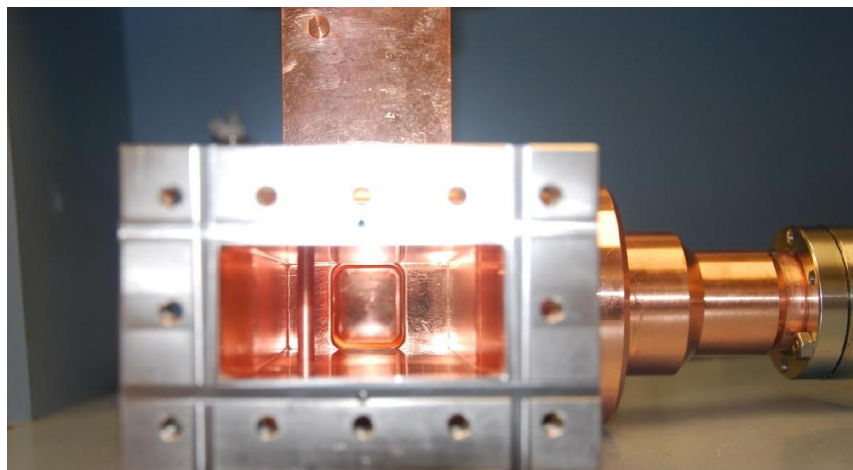

Figure 29. View into one of the WR-284 input waveguides, shown (at left) the tuning pin used for obtaining a near-perfect match. An identical tuning pin is in the second input waveguide.

Table VI lists parameters for the input cavity.

Table VI. Parameters for S-band input cavity.

<i>operating mode</i>	rotating TE <sub>111</sub>
<i>frequency, MHz</i> <i>(in vacuum, expected)</i>	2,856
<i>frequency, MHz</i> <i>(in dry nitrogen, measured)</i>	2,850 -0.6 / +0.85
<i>Q-factor</i>	200 ± 10
<i>number of input ports</i>	2
<i>input power for 7<sup>th</sup> harmonic</i>	~8.5 MW
<i>input power for 2<sup>nd</sup> harmonic</i>	~6 MW
<i>expected surface field, kV/cm</i> <i>7<sup>th</sup> / 2<sup>nd</sup></i>	66 / 46

**Seventh-harmonic output cavity.** The design drawing for the seventh-harmonic output cavity is shown in Figure 30. It is to be tuned to 19.992 GHz, and its  $Q$ -factor is expected to be approximately 900. Its operating mode is rotating-TE<sub>711</sub>, and its output structure, as discussed in Section II, is via 28 coupling slots into a phase-matched wrap-around waveguide. A map of the RF electric field distribution in the mid-plane of the output cavity is shown in Figure 31. In view of the complex output structure of this cavity, a cold test model has been built; design drawings and photographs are shown in Figures 32 and 33.

**Omega-P, Inc.**  
 Final Report on DoE SBIR Phase I Grant DE-FG02-07ER84854  
 Topic 32b: Radio Frequency Power for Linear Accelerators  
**MULTI-MW 22.8 GHz HARMONIC MULTIPLIER –**  
**RF POWER SOURCE FOR HIGH-GRADIENT ACCELERATOR R&D**

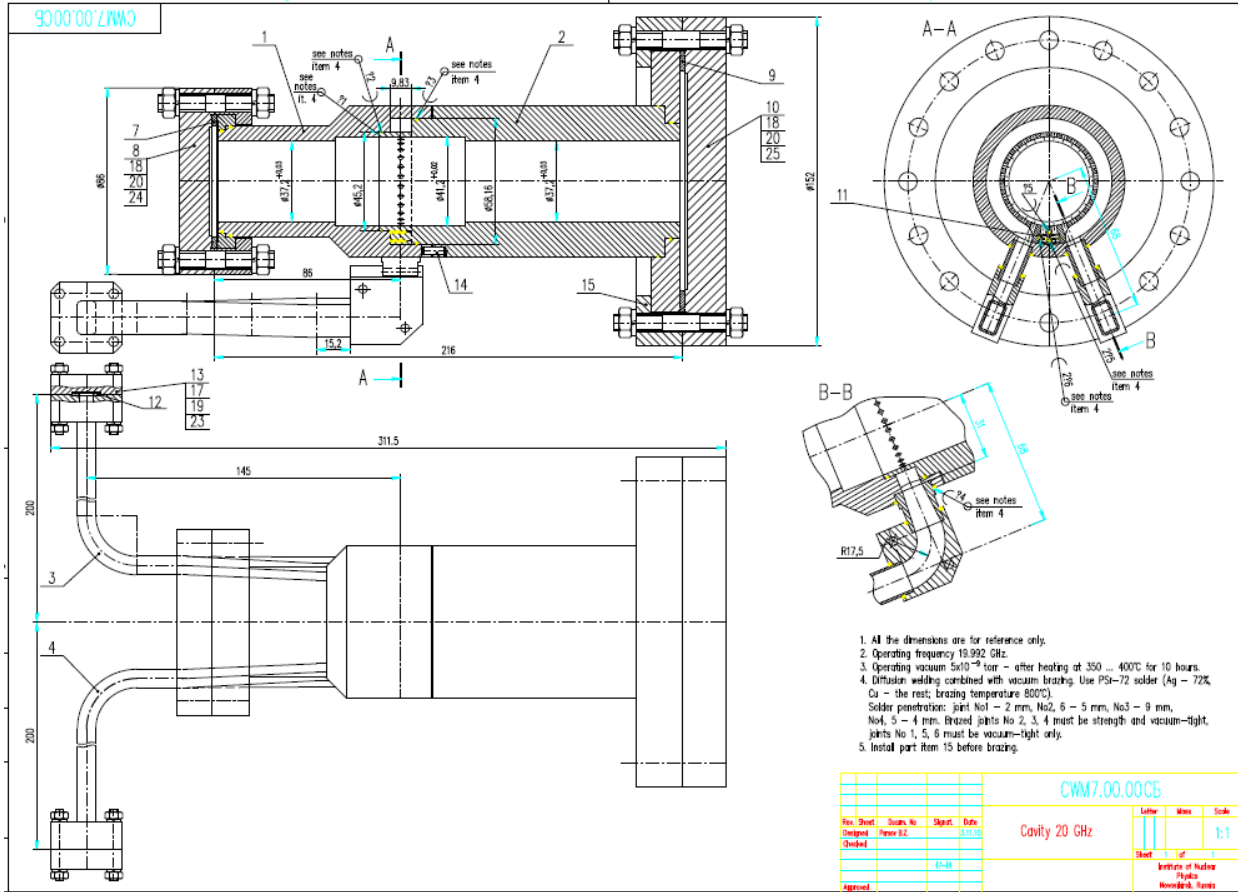

Figure 30. Design drawings for 7<sup>th</sup> harmonic output cavity.

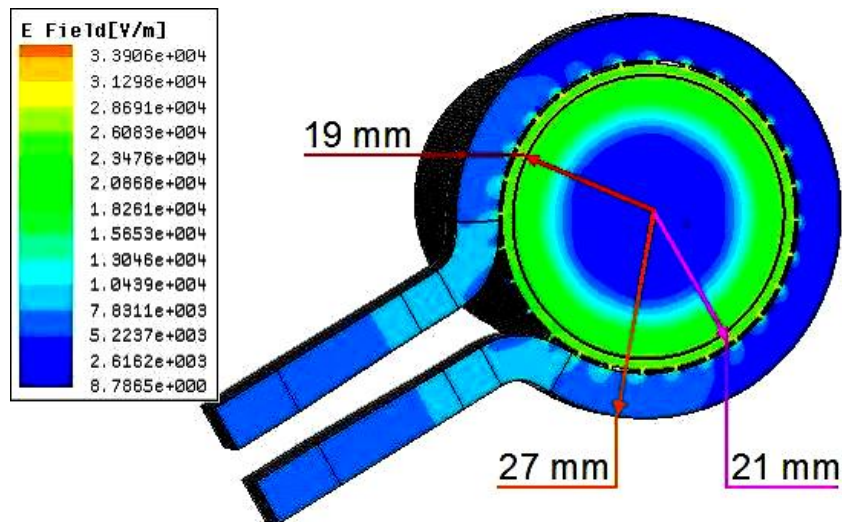

Figure 31. Map of RF electric field distribution in plan of TE<sub>711</sub> mode output cavity at in a plane at the center of the wrap-around output waveguide.

**Omega-P, Inc.**  
 Final Report on DoE SBIR Phase I Grant DE-FG02-07ER84854  
 Topic 32b: Radio Frequency Power for Linear Accelerators  
**MULTI-MW 22.8 GHz HARMONIC MULTIPLIER –  
 RF POWER SOURCE FOR HIGH-GRADIENT ACCELERATOR R&D**

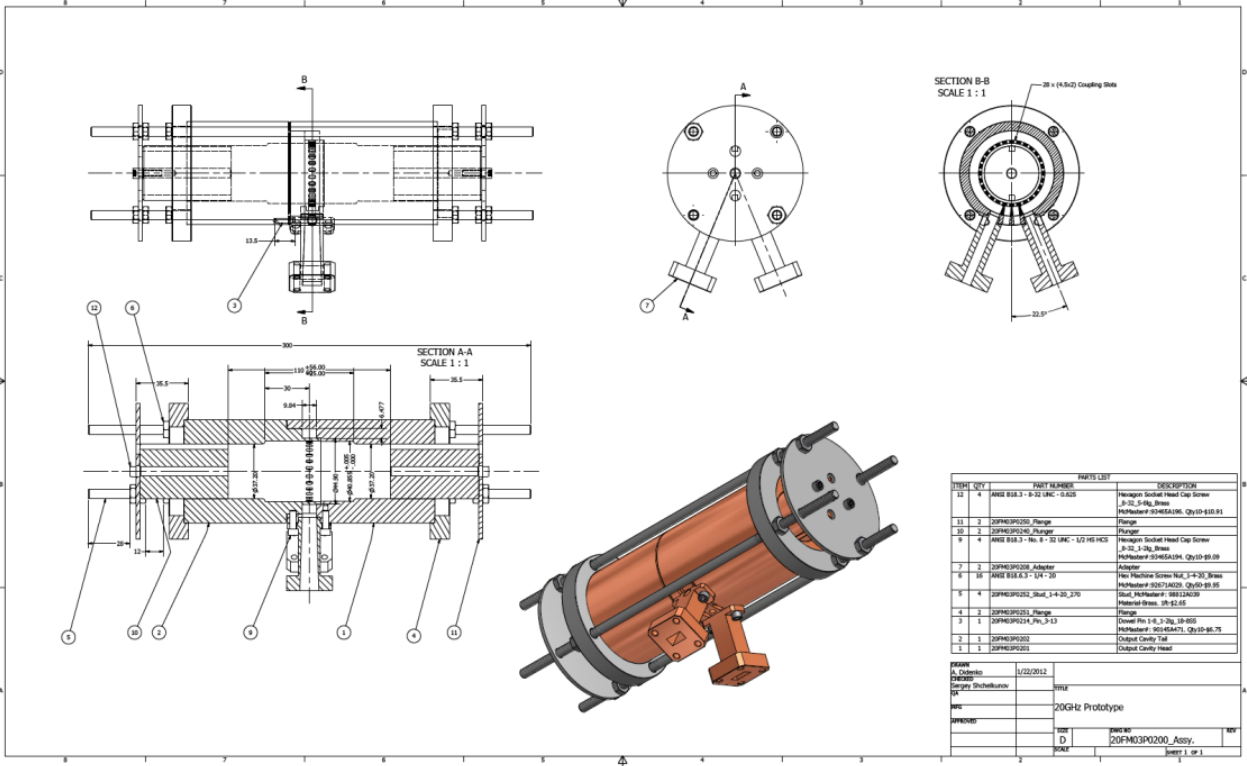

Figure 32. Design drawings and SolidWorks image of cold test version of output cavity.



Figure 33. Parts for cold test version of output cavity.

At this writing, fabrication of the output cavity is nearing completion, with cold tests and any necessary adjustments to be conducted in September 2012.

**Omega-P, Inc.**

Final Report on DoE SBIR Phase I Grant DE-FG02-07ER84854

Topic 32b: Radio Frequency Power for Linear Accelerators

**MULTI-MW 22.8 GHz HARMONIC MULTIPLIER –  
RF POWER SOURCE FOR HIGH-GRADIENT ACCELERATOR R&D**

**Second-harmonic output cavity.** As written above, a second-harmonic output cavity operating at 5.712 GHz (C-band) is also to be employed as part of a test stand for experiments that require two phase-coherent multi-MW powers, in this case 2.856 GHz and 5.712 GHz. This test stand is configured for tests of bimodal cavities that may exhibit lower probabilities of RF breakdown than do single-mode cavities, and of RF gun concepts that are predicted to supply lower-emittance and lower energy-spread beam than single-mode RF guns. Design drawings for the second harmonic TE<sub>211</sub> rotating mode output cavity are shown in Figure 34. With 5.9 MW of S-band drive power in the input cavity, simulations predict the C-band output power to be 5.2 MW—an RF-to-RF conversion efficiency of 88%. A map of the RF electric field distribution in the mid-plane of the output cavity is shown in Figure 35. A SolidWorks image of the cavity is shown in Figure 36, and the configuration of the two-frequency test stand is shown in Figure 37.

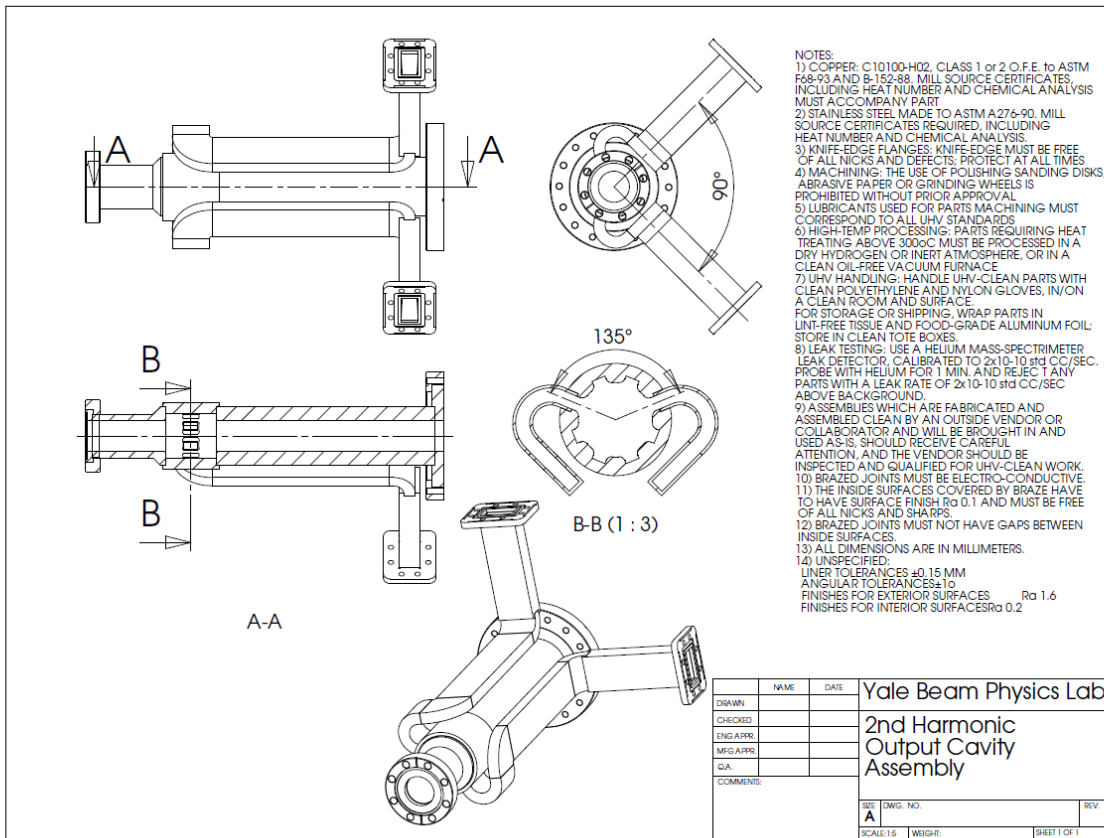

Figure 34. Design drawings for the second-harmonic 5.712 GHz (C-band) output cavity.

*Omega-P, Inc.*

Final Report on DoE SBIR Phase I Grant DE-FG02-07ER84854

Topic 32b: Radio Frequency Power for Linear Accelerators

**MULTI-MW 22.8 GHz HARMONIC MULTIPLIER –  
RF POWER SOURCE FOR HIGH-GRADIENT ACCELERATOR R&D**

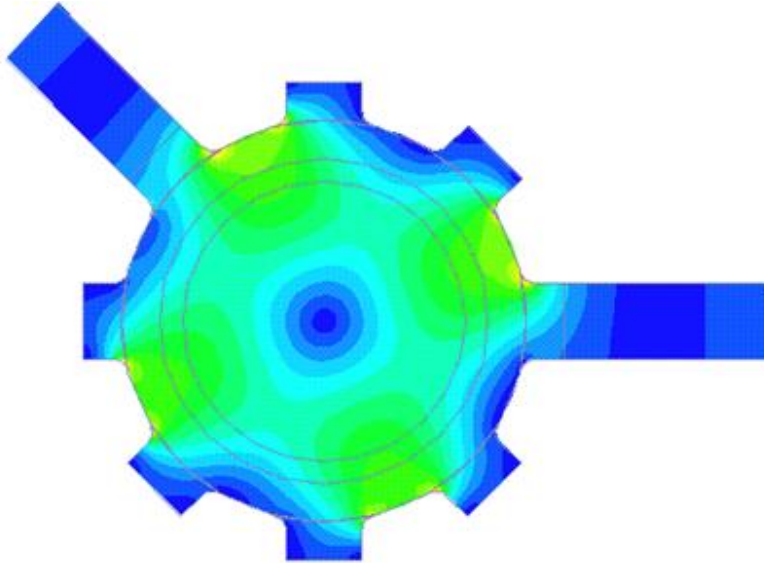

Figure 35. Map of RF electric field distribution in the mid-plane of the C-band output cavity. The two output waveguides spaced by the requisite  $120^\circ$  for extraction of power from a rotating  $TE_{211}$  mode are shown, as well as the six compensating pockets needed to avoid asymmetry in the fields that would be caused by the asymmetrically disposed waveguides.

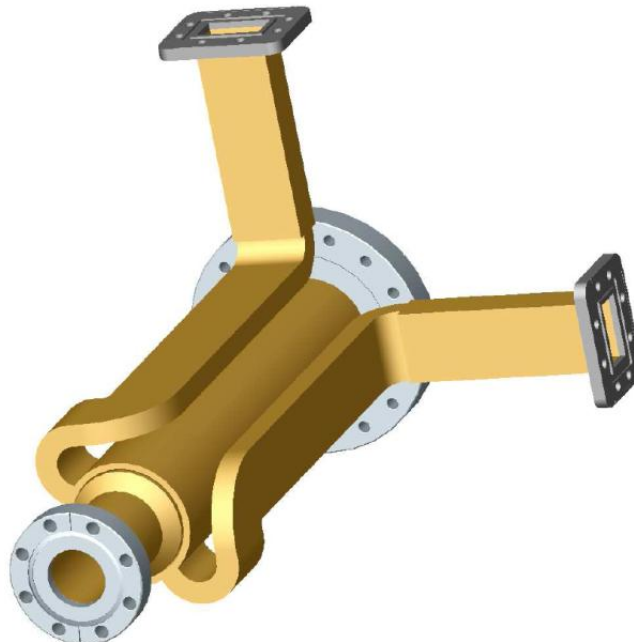
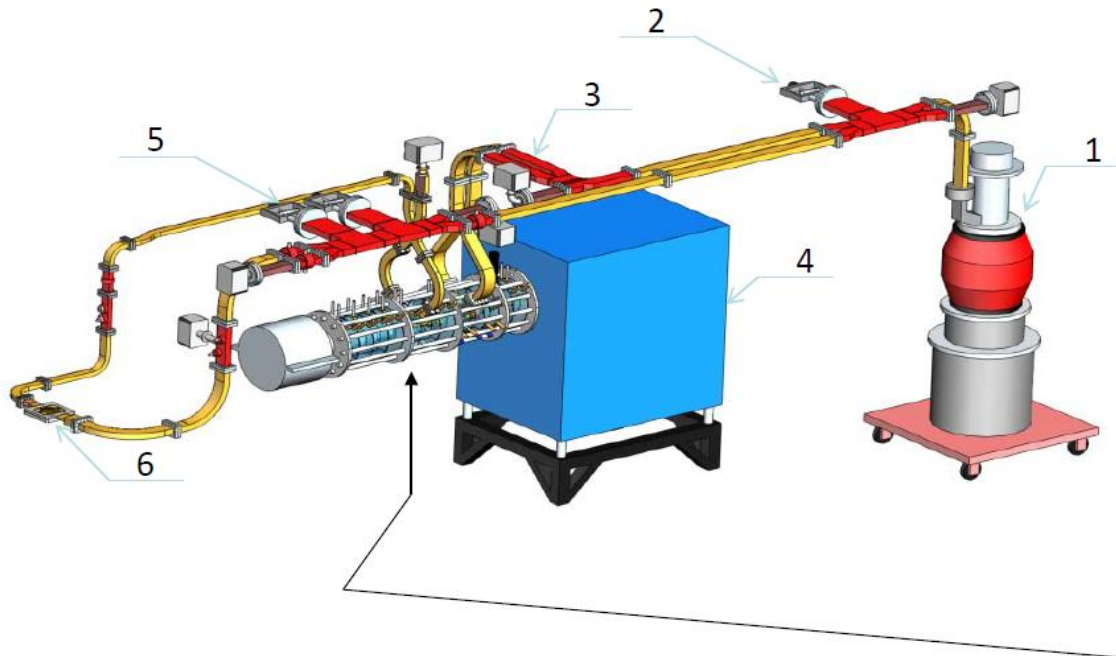

Figure 36. SolidWorks image of the C-band output cavity. Contorted output waveguides are required in order to convey output power beyond the solenoid magnet coils that encircle the entire structure.

*Omega-P, Inc.*  
Final Report on DoE SBIR Phase I Grant DE-FG02-07ER84854  
Topic 32b: Radio Frequency Power for Linear Accelerators  
**MULTI-MW 22.8 GHz HARMONIC MULTIPLIER –  
RF POWER SOURCE FOR HIGH-GRADIENT ACCELERATOR R&D**



*Layout:* 1 – S-band klystron; 2 – variable power splitter; 3 – 3-dB hybrid splitter; 4 – gun tank; 5 – variable power splitter and phase shifter; 6 – bi-frequency device under test.

Figure 37. Image of two-frequency test stand.

**Beam collector.** The insulated beam collector for the 2<sup>nd</sup> and 7<sup>th</sup> harmonic multipliers has been built and tested. It is shown, together with an intermediate spool piece, in Figure 38.



Figure 38. Insulated beam collector (at top), and intermediate spool piece (bottom).



## *Omega-P, Inc.*

Final Report on DoE SBIR Phase I Grant DE-FG02-07ER84854

Topic 32b: Radio Frequency Power for Linear Accelerators

### **MULTI-MW 22.8 GHz HARMONIC MULTIPLIER – RF POWER SOURCE FOR HIGH-GRADIENT ACCELERATOR R&D**

## **V. CONCLUSIONS**

Electrodynamic and particle simulation studies have been carried out to optimize design of a two-cavity harmonic frequency multiplier, in which a linear electron beam is energized by rotating fields near cyclotron resonance in a  $TE_{111}$  cavity in a uniform magnetic field, and in which the beam then radiates coherently at the  $n^{\text{th}}$  harmonic into a  $TE_{n11}$  output cavity. Examples are worked out in detail for 7<sup>th</sup> and 2<sup>nd</sup> harmonic converters, showing RF-to-RF conversion efficiencies of 45% and 88%, respectively at 19.992 GHz (K-band) and 5.712 GHz (C-band), for a drive frequency of 2.856 GHz. Details are shown of RF infrastructure (S-band klystron, modulator) and harmonic converter components (drive cavity, output cavities, electron beam source and modulator, beam collector) for the two harmonic converters to be tested. Details are also given for the two-frequency (S- and C-band) coherent multi-MW test stand for RF breakdown and RF gun studies.

Archival publications that give details on topics covered in this report include:

- M.A.Lapointe, V.P.Yakovlev, J.I.Hirshfield, "High Power seventh harmonic converter at 20 GHz", Proceedings of PAC'2001.
- N.A. Solyak, J.L. Hirshfield, G.M. Kazakevich, M.A.LaPointe, and V.P. Yakovlev, "Multi-MW K-band 7<sup>th</sup> harmonic multiplier for high-gradient accelerator R&D," FERMILAB-CONF-09-184-TD (2009).
- N. A. Solyak, V. P. Yakovlev, S. Yu. Kazakov, and J. L. Hirshfield, "Multi-MW K-band RF source for high-gradient accelerator R&D," AIP Conf. Proc. 1086, pp. 452-457 (2009.)
- Y. Jiang, S. Shchelkunov, V.P. Yakovlev, N. Solyak, S.V. Kuzikov, J.L. Hirshfield, "Multi-harmonic RF test stand for RF breakdown studies," Proc. 2012 Advanced Accelerator Concepts Workshop, Austin TX (2012). (to be published).

## **VI. REFERENCES**

- [1] M.A.Lapointe, V.P.Yakovlev, J.I.Hirshfield, "High Power seventh harmonic converter at 20 GHz", Proceedings of PAC'2001.
- [2] A.S. Chou, W. Wester, A. Baumbaugh, H.R. Gustafson, Y. Irizarry-Valle, P.O. Mazur, J.H. Steffen, R. Tomlin, X. Yang, J. Yoo, "Search for axionlike particles using a variable-baseline photon-regeneration technique," Phys. Rev. Lett. **100**, 080402 (2008); J. Jaeckel, A. Ringwald, "A cavity experiment to search for hidden sector photons," IPPP/07/38; DCPT/07/76; DESY 07-099 (2007); C. Robilliard, et al., (BMV Collaboration), "No light shining through a wall: new results from a photoregeneration experiment," Phys. Rev. Lett. **99**, 190403 (2007).
- [3] Solyak N.A, Balakin V.E, Breznev O.N, et al. "Studying of RF power generator for VLEPP", Workshop on Relativistic RF Electronics, Tomsk, 1980. (in Russian).

*Omega-P, Inc.*

Final Report on DoE SBIR Phase I Grant DE-FG02-07ER84854

Topic 32b: Radio Frequency Power for Linear Accelerators

**MULTI-MW 22.8 GHz HARMONIC MULTIPLIER –  
RF POWER SOURCE FOR HIGH-GRADIENT ACCELERATOR R&D**

- [4] Solyak N.A, Balakin V.E, Kazakov S.Yu, "*RF deflection system of Gyrocon*", Workshop on Relativistic RF electronics, Gorkii, 1982 (in Russian).
- [5] Balakin V.E., Breznev O.N, Novokhatsky A.V, Solyak N.A,et al., "*Studying of Accelerating Structure of Linear Accelerator VLEPP*", Proc. of the VII Conference on Charged Particle Accelerators 1982, Dubna,1983,v.2, p.410.
- [6] Balakin V.E, Breznev O.N, Solyak N.A. et al.,"*Studying of the Powerful pulsed C-band gyrocon*", Proc. X Workshop on Linear Charge Particle Accelerators, Kharkov,1987, pp.43-44.
- [7] Balakin V.E., Syrachev I.V.: 'VLEPP RF Power Multiplier', Proc. III-rd Int. Workshop on Next Generation Linear Collider, Branch INP, Protvino, Russia, 1991.
- [8] Syrachev I.V., Vogel V.F., Mizuno H., Odajiri J., Otake Y., Tokumoto S.: 'The Results of RF High Power Tests of X-Band Open Cavity RF Pulse Compression System', Proc. Int. Conference Linac-94, Tsukuba, Japan, 1994.
- [9] I. Syrachev: 'RF pulse Compressors systems for CTF3', 5-th MDK Workshop, CERN, 2001.
- [10] I.[Syrachev](#), [E. Jensen](#), [Peter D. Pearce \(CERN\)](#), "A novel idea for a CLIC 937-MHz 50-MW multibeam klystron". CERN-CLIC-NOTE-590, CERN-OPEN-2004-002.
- [11] Y. Jiang, S. Shchelkunov, V.P. Yakovlev, N. Solyak, S.V. Kuzikov, J.L. Hirshfield, "Multi-harmonic RF test stand for RF breakdown studies," Proc. 2012 Advanced Accelerator Concepts Workshop, Austin TX (2012). (to be published).
- [12] S.V. Kuzikov *et al* "Two-frequency RF gun with reduced emittance and energy spread," Proc. 2012 Advanced Accelerator Concepts Workshop, Austin TX (2012). (to be published).