

SANDIA REPORT

SAND2013-6655

Unlimited Release

Printed August, 2013

Proceedings of the Third International Workshop on Jointed Structures

Michael J. Starr, Matthew R. Brake, Daniel J. Segalman, Lawrence A. Bergman, and
David J. Ewins

Prepared by
Sandia National Laboratories
Albuquerque, New Mexico 87185 and Livermore, California 94550

Sandia National Laboratories is a multi-program laboratory managed and operated by Sandia Corporation, a wholly owned subsidiary of Lockheed Martin Corporation, for the U.S. Department of Energy's National Nuclear Security Administration under contract DE-AC04-94AL85000.

Approved for public release; further dissemination unlimited.



Sandia National Laboratories

Issued by Sandia National Laboratories, operated for the United States Department of Energy by Sandia Corporation.

NOTICE: This report was prepared as an account of work sponsored by an agency of the United States Government. Neither the United States Government, nor any agency thereof, nor any of their employees, nor any of their contractors, subcontractors, or their employees, make any warranty, express or implied, or assume any legal liability or responsibility for the accuracy, completeness, or usefulness of any information, apparatus, product, or process disclosed, or represent that its use would not infringe privately owned rights. Reference herein to any specific commercial product, process, or service by trade name, trademark, manufacturer, or otherwise, does not necessarily constitute or imply its endorsement, recommendation, or favoring by the United States Government, any agency thereof, or any of their contractors or subcontractors. The views and opinions expressed herein do not necessarily state or reflect those of the United States Government, any agency thereof, or any of their contractors.

Printed in the United States of America. This report has been reproduced directly from the best available copy.

Available to DOE and DOE contractors from
U.S. Department of Energy
Office of Scientific and Technical Information
P.O. Box 62
Oak Ridge, TN 37831

Telephone: (865) 576-8401
Facsimile: (865) 576-5728
E-Mail: reports@adonis.osti.gov
Online ordering: <http://www.osti.gov/bridge>

Available to the public from
U.S. Department of Commerce
National Technical Information Service
5285 Port Royal Rd.
Springfield, VA 22161

Telephone: (800) 553-6847
Facsimile: (703) 605-6900
E-Mail: orders@ntis.fedworld.gov
Online order: <http://www.ntis.gov/help/ordermethods.asp?loc=7-4-0#online>



SAND2013-6655
Unlimited Release
Printed August, 2013

Proceedings of the Third International Workshop on Jointed Structures

Michael J. Starr, Matthew R. Brake, Daniel J. Segalman
Sandia National Laboratories
P.O. Box 5800
Albuquerque, NM 87185-1070, USA

Lawrence A. Bergman
University of Illinois at Urbana-Champaign
306 Talbot Lab
104 S. Wright St.
Urbana, IL 61801, USA

David J. Ewins
Imperial College London
South Kensington Campus
London SW7 2AZ, UK

Abstract

The Third International Workshop on Jointed Structures was held from August 16th to 17th, 2012, in Chicago Illinois, following the ASME 2012 International Design Engineering Technical Conferences and Computers and Information in Engineering Conference. Thirty two researchers from both the United States and international locations convened to discuss the recent progress of mechanical joints related research and associated efforts in addition to developing a roadmap for the challenges to be addressed over the next five to ten years. These proceedings from the workshop include the minutes of the discussions and follow up from the 2009 workshop [1], presentations, and outcomes of the workshop. Specifically, twelve challenges were formulated from the discussions at the workshop, which focus on developing a better understanding of uncertainty and variability in jointed structures, incorporating high fidelity models of joints in simulations that are tractable/efficient, motivating a new generation of researchers and funding agents as to the importance of joint mechanics research, and developing new insights into the physical phenomena that give rise to energy dissipation in jointed structures. The ultimate goal of these research efforts is to develop a predictive model of joint mechanics.

Acknowledgement

The authors thank all of the participants of the workshop for their contributions to the discussion and goals laid out herein. Additionally, we would like to thank Sandia National Laboratories and the Atomic Weapons Establishment for their support of this workshop.

Contents

1. Introduction to the Third International Workshop on Jointed Structures	7
2. Minutes of the Third International Workshop on Jointed Structures	8
List of Attendees	8
Review of Workshop 2 Outcomes – Actions and Challenges	9
Actions from the 2009 Workshop.....	9
Challenges from the 2009 Workshop	11
Community Development.....	11
The ASME Research Committee on the Mechanics of Jointed Structures	11
Mechanical Joints Research Material Depository.....	12
Identification of Strategic Themes.....	12
1. Institutional Structure and Vision	13
2. Fatigue and Contact Mechanics	14
3. Physics-based/data driven modelling.....	15
4. View from Germany	15
5. Flight systems/satellites/weapons	16
6. Vibrations/Turbine engines.....	17
7. Uncertainty Approaches to Joints and Interfaces.....	18
Discussion of Strategic Themes.....	19
1. Institutional Structure and Vision	19
2. Fatigue and Contact Mechanics	19
3. Physics-based/data driven modelling.....	20
4. View from Germany	20
5. Flight systems/satellites/weapons	20
6. Vibrations/Turbine engines.....	21
7. Uncertainty Approaches to Joints and Interfaces.....	21
Challenges, Joints Workshop 2012.....	23
1. Round Robin/Benchmark Exercise for Hysteresis Measurements	23
2. Round Robin/Benchmark for Measurement/Prediction of Dissipation in Standard Joints	23
3. Methodology to Quantify Cost Benefits of Improved Joint Design	23
4. GRAND CHALLENGE – Define Mechanisms of Friction (Interface Mechanics).....	23
5. Modeling Non-Metallics.....	23
6. Multiscale Modeling Framework.....	23
7. Definition of Variability and Uncertainty (linked to Round Robin Challenges 1 and 2, also address how to model in the absence of experimental data)	23
8. Epistemic and Aleatoric Modeling	24
9. Time Varying Model Parameters, Modeling and Experiment “Surface Chemistry”	24
10. The Derivation of Constitutive Equations Based on Physical Parameters (including measurement of spatial dependence of key physical parameters)	24
11. Eventual Implementation of Prediction Methods in Commercial Numerical Codes	24
12. Develop Statement of Mission and Workshop Report	24
Joints Workshop Contact List – September 2012.....	25
3. Presentations	32
1. Workshop Agenda	32
2. Introduction.....	34

3. Actions and Challenges from the 2009 Workshop	36
4. Strategic Themes.....	47
5. The ASME Research Committee on the Mechanics of Jointed Structures	48
6. The Joints Handbook	51
7. Institutional Structure and Vision	57
8. Fatigue and Contact Mechanics	59
9. Physics-Based/Data Driven Modeling.....	71
10. View from Germany	78
11. Flight Systems/Satellites/Weapons.....	84
12. Vibrations/Turbine Engines.....	90
13. Uncertainty Approaches to Joints and Interfaces.....	98
4. Summary	105
5. References.....	106
6. Distribution	107

1. INTRODUCTION TO THE THIRD INTERNATIONAL WORKSHOP ON JOINTED STRUCTURES

The issue of predictive structural dynamics is of fundamental importance in multiple sectors of our economy, including manufacturing, transportation, and defense. Applications are so broad as to include optimal design of jet engine components and the specification of tolerances for nuclear weapon components. It has been recognized since the 1960's that the fundamental barrier to predictive structural dynamic simulation resides in the nonlinearity and variability of the mechanical interfaces of practical structures. Historically, this limitation has been obviated by approximating the structure as a linear system and tuning the linear model for that system to match its measured properties.

Given the tremendous advances in computer resources - particularly massively parallel computers - and advances in experimental techniques, it is appropriate to reexamine the problem to assess the possibility of actually predicting structural dynamic response even before a prototype is constructed. For this purpose the Sandia National Laboratories and the National Science Foundation have sponsored a workshop in Arlington, Virginia, 16-18 October, 2006 [1]. A follow up workshop in Dartington Hall, Totnes, Devon, UK 26-29 April 2009 was sponsored by the British Atomic Weapons Establishment (AWE) and Sandia National Laboratories (SNL). A third workshop was held 16-18 August 2012 at the conclusion of the ASME International Design Engineering Technical Conference in Chicago. This workshop was sponsored by Sandia National Laboratories and the British Atomic Weapons Establishment, and it is this third workshop that is reported here.

Much of the focus of this workshop was on assessing progress made with respect to both the organizational and technical challenges identified in the previous workshop. Among items reported on the first day were the formal creation of an ASME Research Committee on Mechanics of Jointed Structures, the completion of the Sandia Joints Handbook, and the organization of joints-related sessions at various technical conferences. The second day was devoted to technical talks - particularly with respect to the challenges identified in the previous workshop. The morning of third day was spent identifying the next steps with respect to vision and positioning of the joints research community, planning for completion of the challenges identified in the previous workshop, and identification and assignment of new challenges.

Participants in that workshop included distinguished investigators from the United States and Europe representing expertise in the various sciences relevant to this problem. These include vibrations, tribology, elasticity, and computational mechanics. There was an effective balance of capability in theoretical mechanics, computing, and experiment.

2. MINUTES OF THE THIRD INTERNATIONAL WORKSHOP ON JOINTED STRUCTURES

August 16, 2012, Morning Session

The introductory session to this workshop focused on reviewing the results from the previous workshop, discussing the progress made on the challenges and tasks identified at the last workshop, and discussing the other areas of progress since the last workshop.

List of Attendees

Full contact information is given at the end of the meeting notes:

Matt Allen
Ed Berger
Larry Bergman
Matt Brake
Dan Brown
Brandon Deaner
Melih Eriten
David Ewins
Robert Flicek
Lothar Gaul
Muzio Gola
Hugh Goyder
Wes Harris
David Hills
Laura Jacobs
Arif Masud
Randy Mayes
Simon Medina
Marc Mignolet
David Nowell
Evgeny Petrov
Dane Quinn
Pascal Reuss
Dan Segalman
Michael Starr
Bernhard Stingl
Jenny Stroud
Christoph Schwingshackl
Pablo Tarazaga
Liu Tong
Alex Vakakis
Weidong Zhu

Review of Workshop 2 Outcomes – Actions and Challenges

Recall historical development of the meetings:

Sandia, 2000

New Orleans, AFOSR 2001

West Palm Beach, Turbo Expo

During the last session of the Dartington, UK, Workshop, there was a discussion seeking to distill the essential issues and topics which would emerge as the main items defining the new Road Map for the subject. The resulting list divides into 2 sets – Actions and Challenges. The Actions are tasks that are essentially short-term goals deemed to be necessary in order to consolidate the foundations of the subject to provide a sound basis for further research. The Challenges are much more substantial tasks, each requiring several man-years of research effort, whose objectives are to move the whole subject on to a new level of technical competence, heading to the ultimate goals of the ability to model, and to predict the dynamics of mechanical joints and thereby to design structures with optimal dynamic properties – including those whose dynamics are actively controlled by the joints themselves. In many cases, offers of leadership of the tasks were recorded as were expressions of interest in participation. The outcomes of each of the challenges given under each element

From the last workshop, the following Actions and Challenges were identified:

Actions from the 2009 Workshop

1. Terminology & Vocabulary (*Segalman; Bergman*)

A modest list of vocabulary was compiled and published. Comments from members were solicited in order to iterate on the development of the list.

2. Develop Hills Chart (*Dini; Berger*)

It is difficult to assess spatial location of understanding/length scale relationship outside of one's field of expertise. There is still some value in the notional idea. Perhaps we should construct diagrams actively within the community through the website.

3. Classification of Standard Joint Types (*Hills; Vakakis; Starr*)

Short descriptions of classical contact definitions and standard joint interfaces have been compiled.

Perhaps we should look to machine elements standards, and draw knowledge from the design community for the role of joints in dynamics. Then, ask the question, 'Why are we necessary?' We must distinguish ourselves from the knowledge of the design community.

How do mechanisms couple with the ultimate dynamics?

We have to answer the questions of people in industry. Should we restrict ourselves to a certain class of contact? We're not necessarily interested in the "glue" but rather the influence of the interface on the response of the structure. **The joint is the interface**; the properties of the materials may or may not be required to proceed with modeling.

Should we focus on active or passive joints? (or both?)

We should ask for contributions from the community about classifications.

4. Classification/Cataloging of
 - (a) Non Linearity ID Methods (*Vakakis*)

There is a paper on this work in Mech. Syst. Signal Processing.

- (b) Modeling approaches (*Polycarpou; Quinn*)

This starts with the Joints Handbook, and is an ongoing action. Dane Quinn will be the lead for this element going forward.

- (c) Measurement methods (*Nowell; Bergman; Akay*)

This is bigger than just making a list of measurement methods.

5. Benchmark current computation multi-scale methods against analytic solutions (*Masud; Laursen; Quinn*)

This work is in progress. Quasi-continuum approaches are needed, but system-based approaches have not yet been developed.

We should consult Kai Willmer – Nurnberg, and elevate this task to a Challenge.

6. Create a formal Joints Modelling Network (or Community) with more frequent and regular contacts (this was expressed emphatically); meetings at relevant conferences; workshop series;... Wiki..Joints Chat room (*Ewins; Segalman; Nowell; Bergman; Gaul; Green; Surampudi; Dini; Quinn*)

YES! See

https://community.asme.org/research_committee_mechanics_jointed_structures/w/wiki/3787.about.aspx

Challenges from the 2009 Workshop

1. Round Robin/Benchmark Exercise for Hysteresis Measurements (*Ewins; Nowell; Gola; Polycarpou; + possibly Epsilon(Technion)*)

This is still an activity that must be pursued. Interested parties include: Imperial, Torino, Eriten, and Schwingshackl.

2. Round Robin/Benchmark for Measurement/Prediction of Dissipation in Standard Joints (*Leming**; *Goyder; Gaul; Ind; Vakakis*) *task moved to *Jacobs*

This challenge will be kept, but it must have a timescale. Additional interested parties include: Jacobs, Segalman, Allen, and Eriten.

3. Repeatability (measurement-to-measurement) and Variability (unit-to- unit) Issue: need to be able to distinguish between, and to greatly improve performance in both aspects (i.e. design of better, more repeatable joints) (*Leming; Goyder; Gaul; Ind; Polycarpou; Farris; Mignolet*)

The problem is funding! There are no collaboration at all, yet. Should we make a regular meeting location associated with a conference?

4. Framework for multi-scale modeling (*Masud; Dini; Nowell*)

Elevated from Action 5.

Community Development

The ASME Research Committee on the Mechanics of Jointed Structures

With respect to Action 6 above, the ASME Research Committee on the Mechanics of Jointed Structures has been created. We should seek to develop means of giving standing to the group.

For participating members, replace Andreas Polycarpou with Matt Brake on the Events Subcommittee

On the Publications Subcommittee, Lothar Gaul, Matt Allen, Weidong Zhu, and Wes Harris will replace Ed Berger and Arif Masud.

It was suggested (Gaul) that we make IDETC a regular meeting place for the members of the research committee. Other suggestions are Turbo Expo (Petrov), Recent Advances in Dynamics, or organize or own conference. Attendees were polled on likely conference attendance and the following conference attendance counts were:

IDETC – 12
IMECE – 3
Turbo Expo – 5
Tribology – 5
IMAC – 12
SEM – 0
AIAA – 0

Mechanical Joints Research Material Depository

We must establish a depository for works on mechanical joints

This depository should be

- open source
- administered by the committee
- include links to PhD theses
- potentially include conference announcements and job postings

Dartington Workshop Report: SAND2010-5458

Sandia Joints Handbook: SAND2009-4164

Research Committee Site: <http://go.asme.org/mjs>

Temporary website at Imperial: <http://www3.imperial.ac.uk/medynamics/joints>

Pablo has “volunteered” to work on developing/maintaining a research group website.

The secretary will pursue membership in the committee for all workshop attendees.

Identification of Strategic Themes

August 16, 2012, Afternoon Session

The afternoon session of the workshop was focused on identifying strategic themes and challenges for the community.

Presenters were given the following guidelines:

Objectives: to identify the major research themes for the next 5-10 years

Brief introductory remarks (10-15 minutes) on your research focus area. We would like to initiate discussion related to your focus area while addressing the overarching question:

How does this area fit into the larger research community? It is desired that your prepared remarks be more than simply addressing your current research, but should be strategic in content. For instance: enumeration of what we cannot now do well with respect to joints.

Some basic questions that you might consider discussing are:

1. What are the important problems in your area?
2. How do you decide which problems you take on?
3. Who will be the end user of the results of your work?
4. How do you get funding?

The following topics and speakers were invited to present:

1. Institutional Structure and Vision (Alex Vakakis)
2. Fatigue and Contact Mechanics (David Hills and David Nowell)
3. Physics-based/data driven modeling (Melih Eriten)
4. View from Germany (Lothar Gaul and Bernhard Stingl)
5. Flight systems/satellites/weapons (AWE/Sandia)
6. Vibrations/Turbine engines (Muzio Gola and Christoph Schwingshackl)
7. Uncertainty Approaches to Joints and Interfaces (Marc Mignolet)

1. Institutional Structure and Vision

We must educate undergrad and graduate students alike.

In order to promote joints research as an important topic, we must make a case for it.

We need sustained funding! Or else this will not be a first priority. Any proposed institutional structure should facilitate this.

We must develop a research plan that can initiate a dialog, such as the benchmarking of computational and experimental problems.

- Choose benchmarks through dialog with industry
- Define a set of “real” problems (interesting and difficult)
- Form teams to address these problems from different perspectives (competition is alright, we need to be challenged!)
- Show what we can do

Define a Grand Challenge – What is the challenge?

What is the cost to industry of not understanding joint dynamics?

- Promote (with industry) ideas to government

- Topics such as weight savings in engines and flight structures
- Can industry tell us, ‘if there was a redesign of an interface, life would change dramatically.’
- Examples of academic-industry research consortiums/collaborations include:
 - o INSIC (the Information Storage Industry Consortium) for industrial/academic collaborations on data storage research.
 - o Fatigue and fracture
 - o Industry funds short term; government long-term
 - o MURI – Multi-disciplinary University Research Institution
 - Topics released every four years
 - Can we (with industry) influence the topic

Industry must be engaged in order to achieve these goals though, both in the committee and in our symposiums/workshops.

The next generation of joints must be both lighter and more predictable. We must also think about developing smart/active joints that are applicable to energy harvesting, active control for dissipation, or even structural health monitoring.

2. Fatigue and Contact Mechanics

We need to measure the stiffness of interfaces (both normal and tangential)

Measurements of stiffness, including time dependence, must reconcile:

- Measuring techniques
- Tribology
- Models for wear

We don’t know how to measure some important things yet.

We must develop an understanding of the non-orthogonal nature of contact

- Shakedown works for plasticity because it’s orthogonal. In friction, it’s not though.

Why is damping repeatable in some interfaces and not in others?

This is a fundamental question.

Research shows that the preloading of structures (the order, amount, etc.) matters in terms of whether sticking or slipping occurs. This leads to the hypothesis:

Hypothesis: the variation in preloading is a major source of variability in joint response.

3. *Physics-based/data driven modelling*

There is a high need for reduced-order models that incorporate

- Multiple length scales
- Multiple time scales
- Coupled DOFs
- Joint fretting apparatus
- Interface constitutive models

Non-linear system identification is a top-down approach

We may be able to handle more complex phenomena with such a global approach.

However, it's not physics-based.

An example of scale issues:

- Modelling a car, 10^6 DoF, length scales on the order of meters, time scales on the order of seconds
- Modelling the car's engine, 10^5 DoF, length scales on the order of centimeters, time scales on the order of milliseconds
- Modelling piston contact, 10^4 DoF, length scales on the order of microns, time scales on the order of microseconds

A key challenge that will evolve out of this understanding of scale issues is that once an asperity/local model is developed, how does it get built up to the joint/component level?

4. *View from Germany*

The identified needs are:

- Local joint models
- Nonlinear finite element joint models
- Parameter identification from isolated joints

Fundamental research includes:

- Greenwood-Williamson, stochastic, fractal (surface roughness)
- Non-linear normal and tangential contact equations
- Modelling epistemic and aleatoric uncertainty

Damping in the design phase

- Motors
- Bolted joints in cylinder, gearbox, etc.
- Seal systems

Other major problems to be considered:

- Uncertainty description of assembled structures

- Bolted joint damping layers
- Control Problems
- Brake dynamics
- Brake squeal/ nonlinearities in brake systems
- Implementation in commercial software
- Model order reduction
- Non-linear stability analysis/limit cycle calculation
- Is Coulomb friction sufficient?
- Failure of joints – Derivation of design rules, monitoring
- Multiscale systems – structure of interface dynamics, scales may interact

Funding is provided by

- FVV
- DFG (German Research Society)
- Research groups
- Industrial transfer (NSF 50/50)

Grand Challenge: measuring microslip inside the contact patch.

Why not leverage work in other fields? Earthquake and tectonic slip modelling has developed higher order friction laws. Can we learn anything from these? One example of an improved approach is the use of a bristle model based on asperity dynamics to represent friction.

5. Flight systems/satellites/weapons

One new focus area for this area of work is tape joints

- Modelled as softening Duffing oscillators
- However, the structure can evolve through testing

The key idea for modelling is to supplement high fidelity FEA with small scale tests. This requires us to isolate key effects for study in experiments.

Issue of epistemic (e.g. model form error) and aleatoric (e.g. parameter based) uncertainty. Uncertainty model should be included early on in an analysis so that it is directly incorporated throughout the results.

Having a model is not enough. The ultimate goal is to have a model that can be used. What use is something if it results in simulations that are so computationally expensive that solutions to real problems become impractical? For instance, Iwan models are a great first pass, but between the parameters needed, computational time, and difficulty implementing, they're not being adapted even by our own analysts.

Grand Challenge: We need to predict and design joints to do what we want them to do. Instead of being a source of uncertainty, the ultimate goal is to be able to use them to condition and improve the dynamics of a system.

6. Vibrations/Turbine engines

Imperial College London

Analytical research problems include

- Friction contact elements
- Bifurcation and instability
- GUI
- Application to aircraft engine: methodology, response behaviour
- Validation

Nonlinear structural damping problems include

- Engine components
- Rotating and stationary systems

Measurement techniques include

- Large amplitude excitation
- Data processing
- Novel test methods

Robust prediction methods are needed given

- Macro-level responses
- Variability of joints
- Contact conditions unknown

The ultimate goal is to predict the overall dynamic response and the effect of a joint on a system's stiffness and damping

A second goal is to design intolerant joints, taking into account

- Manufacturing tolerances
- Wear
- Damping

Likewise, simulation and modelling efforts must be

- Fast and reliable
- Able to serve as criteria for effective joint design

A major challenge is non-linear friction joint validation

University of Torino

The focus of their research is developing models and software to study

- Contact mechanics and tribology
- Turbine and gear dynamics
- Damping and wear assessment
- Damper mechanics

- Contact modelling on rotating components

If we can improve the predictive power of models, then we can reduce the amount of testing that is necessary

Their other major thrust is in the validation of contact models

Funding:

Discussions within institutions

Government/industry partnerships

- Fiat
- GE
- Avio
- Turbogas & Steam
- ANSALDO

European projects

7. Uncertainty Approaches to Joints and Interfaces

There are two major classes of uncertainty that must be considered:

Epistemic uncertainty – when the model doesn't match the physics despite tuning.

Aleatoric uncertainty – parameter based uncertainty or uncertainty due to variations in part parameters.

We need to start thinking about building models while simultaneously including uncertainty. It does not make sense to subsequently add uncertainty.

To do this, variables need to be defined stochastically instead of deterministically.

Discussion of Strategic Themes

August 17, 2012, Morning Session

From August 16th's afternoon's activities, each focus area presenter was asked to produce a list of the three most important elements (short and long term) to make progress in their focus area. Those elements are recorded here.

1. Institutional Structure and Vision

How do we define a Grand Challenge?

1. Discuss with stakeholders
2. Define deliverable date, e.g. deliver report at next IDETC on progress/actions

Proposed Grand Challenge:

Cost benefit of reducing the weight of a joint

- Cost of joint failures
- Time to design
- Opportunity cost

Produce a statement of mission goals of the research group

2. Fatigue and Contact Mechanics

2-1. Measurement of contact stiffness

- How can it be measured?
- Understanding techniques

2-2. Variability in joints

- Frictional shakedown
- Dependence on initial conditions

GRAND CHALLENGE

2-3. Mechanisms of friction

- **What causes energy loss?**
- **What are the relevant length scales?**
- **This type of problem cannot be solved by us alone; we must involve experts/insights from other fields**
- **We want an understanding for an engineering perspective based on detailed scientific study**

- 2-4. Extending modeling scope
- non-metals, e.g. rubber, gaskets
 - thermomechanical contact problem

3. *Physics-based/data driven modelling*

- 3-1. Interface mechanics modeling
- bridging multiscale, temporal and spatial

- 3-2. Variability and uncertainty
- stochastic modeling

- 3-3. Proceed in both directions of modeling
- top-down
 - bottom-up

Different levels to consider:

Atoms – Grains – Asperities – Waviness – Contact Front – Contact Patch – Interface - Structure

4. *View from Germany*

- 4-1. Derive constitutive equations based on physical parameters
- Hardness
 - Asperity distributions
 - Surface chemistry
- Parameters are independently measurable

4-2. Compare models (simulations) of the same hardware using different measurement techniques:

- Optoelectronic, etc.
- Transient, steady-state

Are lap joints the best specimen to perform benchmarking studies?

- ball-on-flat
- dovetail

4-3. Compare non-local with local friction descriptions, (local - Coulomb, non-local - bristle model)

- **Grand Challenge: Can we predict the coefficient of friction based off of the material properties and geometries?**

4-4. Compare the performance of passive, semi-active, and active joints.

5. *Flight systems/satellites/weapons*

5-1. Bottom-up approach to modelling structures

- Better ways to parameterize models
- Better ways to implement in FE models
- Better joint models (higher dimension)
- Enlarge catalogue of existing models

5-2. We need to engage analysts, and to differentiate between research tools and production tools
We shouldn't come up with models in a vacuum and not think about how to implement them.
We need to engage code/software developers, and eventually companies too.

5-3. How do we model joints in the absence of experimental data?

5-4. Engage the broader community

- Industry
- Funding agencies
- Code developers (we should begin the integration of theory and codes at an earlier stage)
- Panel discussion at symposium comprised of code developers

6. Vibrations/Turbine engines

6-1. Toolkit for modeling

- Experimental and analytical
- Hierarchical

GRAND CHALLENGE

6-2. Develop prediction tools to design joints to perform “optimally”

We want to predict and design joints to do what we want them to do. Instead of being a source of uncertainty, the ultimate goal is to be able to use joints to condition and improve the dynamics of a system.

7. Uncertainty Approaches to Joints and Interfaces

7-1. Get data!

A simple benchmark structure is needed. Data are structure dependent:

- Load
- Displacement
- Time histories
- “Slip”
- Part-to-part
- Assembly/disassembly
- Yield predictions of uncertainty

7-2. We must reassess deterministic modelling

Put uncertainty into such models and identify where uncertainty analysis is necessary

7-3 How do you discover model form error?

- Hierarchical constitutive models, enforce thermodynamic consistency

7-4 Can we use uncertainty principles to guide modelling techniques?

- Sensitivity analysis (no data required)
- Uncertainty (requires data)

Reducing order of model through such analysis

(see Michael Hanss “Applied Fuzzy Arithmetic”)

Another central question is ‘Is epistemic error hidden by aleatoric uncertainty when we compare nonlinear models?’ In order to assess this, we need to look at large, complex structures that people are using linear models to represent joints. How are the results affected when we consider joint models, and when we incorporate parameter variation? Do we have an issue that the missing physics in the model negates the advantage of using supercomputing, or does aleatoric uncertainty dominate the variation in the results?

Challenges, Joints Workshop 2012

Out of the discussions of requirements to make progress in our focus areas, a new set of challenges has been developed. This is the principle outcome of the Joints Workshop. Each of these challenges is associated with a set of deliverables. The challenges are listed here.

1. Round Robin/Benchmark Exercise for Hysteresis Measurements (Ewins, Nowell, Gola, Eriten, Schwingshackl)

December 2012 – Define scope, hardware, measurement technique

April 2013 – Mid-year progress report

September 2013 – Report results

2. Round Robin/Benchmark for Measurement/Prediction of Dissipation in Standard Joints

(Jacobs, Goyder, Gaul, Ind, Vakakis, Allen, Eriten, Harris, Segalman)

December 2012 – Define scope, hardware, measurement technique

April 2013 – Mid-year progress report

September 2013 – Report results

3. Methodology to Quantify Cost Benefits of Improved Joint Design (Brake, Goyder, Ewins, Reuss, Schwingshackl, Allen)

December 2012 – Draft delivery

*4. **GRAND CHALLENGE** – Define Mechanisms of Friction (Interface Mechanics)* (Nowell, Brake, Eriten)

January/February 2013 – “Green” paper

5. Modeling Non-Metallics (Gaul, Goyder, Petrov)

February 2013 – “Green” paper

6. Multiscale Modeling Framework (Eriten, Masud, Petrov)

February 2013 – “Green” paper

7. Definition of Variability and Uncertainty (linked to Round Robin Challenges 1 and 2, also address how to model in the absence of experimental data) (Mignolet, Starr)

January 2013 – Framework for data/criteria

8. Epistemic and Aleatoric Modeling
(Segalman, Bergman, Brake, Vakakis, Willner)

January 2013 – Problem definition

9. Time Varying Model Parameters, Modeling and Experiment “Surface Chemistry”
(Dini, Medina, Eriten, Schwingshackl)

April 2013 – Problem definition, including scales, wear, meeting at ISFF7

10. The Derivation of Constitutive Equations Based on Physical Parameters (including measurement of spatial dependence of key physical parameters)
(Gaul, Hoffmann, Starr, Mayes)

January 2013 – “Green” paper

11. Eventual Implementation of Prediction Methods in Commercial Numerical Codes
(Brown, Goyder, Petrov, Brake)

January 2013 – “Green” paper

12. Develop Statement of Mission and Workshop Report
(Ewins, Bergman, Starr)

Joins Workshop Contact List – September 2012

Dr. Matthew S. Allen

Assistant Professor, Department of Engineering Physics
University of Wisconsin-Madison
535 Engineering Research Building
1500 Engineering Drive
Madison, WI 53706
Tel: 608-890-1619
Mobile: +001 505-615-1793
msallen@engr.wisc.edu
<http://silver.neep.wisc.edu/~msallen>

Dr. Edward J. Berger

Associate Dean for Undergraduate Programs, and
Associate Professor, Department of Mechanical and Aerospace Engineering
School of Engineering and Applied Science
University of Virginia
Charlottesville VA 22904
office: +1 434-924-6326
Fax: 434.924.0702
berger@virginia.edu

Professor Lawrence A. Bergman

Department of Aerospace Engineering
University of Illinois at Urbana-Champaign
104 South Wright St.
MC-236
321E Talbot Laboratory
Urbana, IL 61801
Tel : 217-333-4970
lbergman@illinois.edu
<http://www.ae.illinois.edu/people/faculty/bergman.html>
LNDVL: <http://lndvl.mechse.illinois.edu>

Matthew R. Brake, Ph.D.

Component Science and Mechanics
Sandia National Laboratories
P.O. Box 5800, MS 1070
Albuquerque, NM 87185-1070, USA
+1 505 284 3351 (voice)
+1 505 844 3278 (fax)
mrbrake@sandia.gov

Daniel Brown

DSE/SED/Structural Dynamics
AWE, Aldermaston, Reading, RG7 4PR
Direct: 0118 98 27570
Daniel.Brown@awe.co.uk

Brandon Deaner

University of Wisconsin – Madison
bdeaner@wisc.edu

Dr. Daniele Dini

Senior Lecturer
Department of Mechanical Engineering (Room 696, Tribology Group)
Imperial College London
[Exhibition Road, London SW7 2AZ](#)
Tel.: [+44 \(0\)2075947242](tel:+44(0)2075947242),
Fax: [+44 \(0\)2075947023](tel:+44(0)2075947023),
Email: d.dini@imperial.ac.uk
URL: www.imperial.ac.uk/people/d.dini

Melih Eriten

University of Wisconsin – Madison
2039 Mechanical Engineering Building
1513 University Ave.
Madison, WI 53706
Tel: +1-608-890-4899
eriten@engr.wisc.edu

David J Ewins FRS FREng FCGI

Professor of Vibration Engineering
Imperial College London
South Kensington Campus
London SW7 2AZ UK
t: +44 208 594 7068
m: +44 7785 256929
e: d.ewins@imperial.ac.uk

Al Ferri, Ph.D.

George W. Woodruff School of Mechanical Engineering
Georgia Institute of Technology
Atlanta, GA 30332-0405
Tel: 404-894-7403
Fax: 404-894-8496
al.ferri@me.gatech.edu
<http://www.me.gatech.edu>

Robert Flicek

University of Oxford

robert.flicek@eng.ox.ac.uk

Dr.-Ing. Lothar Gaul

Director Institute of Applied and Experimental Mechanics (IAM)

University of Stuttgart

Pfaffenwaldring 9

70550 Stuttgart Germany

gaul@iam.uni-stuttgart.de

Prof. Muzio Gola

Politecnico di Torino

corso Duca degli Abruzzi 24

10129 Torino; Italy

m: +393355304868

f: +390110906999

muzio.gola@polito.it

Hugh Goyder

Cranfield University

Defence Academy of the United Kingdom

Shrivenham

Swindon

SN6 8LA, UK

Tel: +44 (0) 1793 785122

Mob: +44(0)7804 252770

h.g.d.goyder@cranfield.ac.uk

Wes Harris

System Dynamics Test and Analysis

Rolls-Royce Corporation

450 South Meridian Street

Office Speed Code MC-S2-02

Indianapolis, IN 46225-1103

Phone: 317-230-6903

wesley.harris@rolls-royce.com

David Hills

Department of Engineering Science,

University of Oxford,

Parks Road

OXFORD

OX1 3PJ

Tel +44 1865 273119

Mob 07704325844

david.hills@eng.ox.ac.uk

Philip Ind

Structural Dynamics, Engineering Analysis & Test Group
AWE, Aldermaston, Reading, RG7 4PR

Direct: 0118 9826970

Philip.Ind@awe.co.uk

Laura Jacobs, Ph.D.

Experimental Environmental Simulations
Sandia National Laboratories

P.O. Box 5800, MS 0557

Albuquerque, NM 87185-0557, USA

+1 505 844 8521 (voice)

ldjacob@sandia.gov

Arif Masud

Professor, and Robert H. Dodds Faculty Scholar
Department of Civil and Environmental Engineering

Affiliate Professor,

Department of Aerospace Engineering,

Computational Science and Engineering,

Micro-&-Nanotechnology Laboratory

University of Illinois, 3110 Newmark Lab, MC-250

205 N. Mathews Ave., Urbana, IL 61801-2352

Telephone: (217) 244-2832

Fax: (217) 265-8039

E-mail: amasud@uiuc.edu

Website: <http://cee.illinois.edu/faculty/masud>

Randy Mayes

Experimental Mechanics/NDE

Sandia National Laboratories

P.O. Box 5800, MS 0557

Albuquerque, NM 87185-0557, USA

+1 505 844 5324 (voice)

+1 505 844 0078 (fax)

rlmayes@sandia.gov

Dr. Simon Medina

Tribology Group

Department of Mechanical Engineering

Imperial College London

London, UK, SW7 2AZ

Tel: +44 (0)20 7594 7236

s.medina@imperial.ac.uk

Marc Mignolet

School for Engineering of Matter, Transport and Energy
Arizona State University
P.O. Box 9309
Tempe, AZ 85287-9309
marc03@asu.edu

Professor David Nowell M.A., D.Phil., C.Eng., F.I.Mech.E., ILTM

Dept of Engineering Science
University of Oxford
Parks Rd
Oxford OX1 3PJ
Tel +44 1865 273184
Fax +44 1865 273906
david.nowell@eng.ox.ac.uk

Dr. Evgeny Petrov

Reader in Structural Dynamics
School of Engineering and Informatics
University of Sussex
Brighton BN1 9QT, United Kingdom
Tel.: +44 (0) 1273 872 537
Email: y.petrov@imperial.ac.uk

D. Dane Quinn

Department of Mechanical Engineering
The University of Akron
Akron, OH 44325-3903
330-972-6302
quinn@uakron.edu

Dipl.-Ing. Pascal Reuss

Institute of Applied and Experimental Mechanics (IAM)
University of Stuttgart
Allmandring 5B
70550 Stuttgart Germany
Tel: +49 (0) 711 /6 85-68166
Fax: +49 (0) 711 /6 85-68169
reuss@iam.uni-stuttgart.de

Christoph Schwingshackl

Lecturer in the Dynamics Group
Room 565b, Mechanical Engineering
Imperial College
Exhibition Road
London SW7 2AZ
Tel: +44 (0)207 594 1920
Fax: +44 (0)207 594 1560
Email: c.schwingshackl@imperial.ac.uk

Dan Segalman

Multi-Physics Modeling and Simulation
Sandia National Laboratories
P.O. Box 969, MS 9042
Livermore, CA 94551-0969, USA
+1 925 294 2734 (voice)
+1 925 294 1459 (fax)
djsegal@sandia.gov

Michael Starr

Component Science and Mechanics
Sandia National Laboratories
P.O. Box 5800, MS 0346
Albuquerque, NM 87185-0346, USA
+1 505 284 9614 (voice)
mjstarr@sandia.gov

Dipl.-Ing. Bernhard Stingl

Hamburg University of Technology
Institute of Mechanics and Ocean Engineering
Eissendorfer Strasse 42
Room 0517
D-21073 Hamburg
Germany
Tel.: 040/42878-2702
Fax: 040/42878-2028
URL: [http://www.mum.tu-harburg.de/
bernhard.stingl@tu-harburg.de](http://www.mum.tu-harburg.de/bernhard.stingl@tu-harburg.de)

Jenny Stroud

Directorate of Systems Engineering
AWE, Aldermaston, Reading, RG7 4PR
Direct: 0118 98 54178
Jenny.Stroud@awe.co.uk

Pablo A. Tarazaga

Assistant Professor
Center for Intelligent Material Systems and Structures
Department of Mechanical Engineering
309 Durham Hall, MC 0261
Virginia Tech
Blacksburg, VA 24061
Phone: 540 231-2906
Fax: 540 231-2903
pablotarazaga@vt.edu

Liu Tong

Politecnico di Torino
Italy
tong.liu@polito.it

Alexander F. Vakakis

W. Grafton and Lillian B. Wilkins Professor,
Department of Mechanical Science and Engineering
Affiliate Professor,
Department of Aerospace Engineering
University of Illinois at Urbana - Champaign
3003 Mechanical Engineering Laboratory
1206 W. Green Str.
Urbana, IL 61801
Tel. (217) 333-3048 (O)
Fax (217) 244-6534
E-mail: avakakis@illinois.edu
Home page: <http://www.mechse.uiuc.edu/faculty/avakakis>
LNDVL: <http://lndvl.mechse.illinois.edu>

Weidong Zhu, Ph.D.

Professor
Department of Mechanical Engineering
University of Maryland, Baltimore County
1000 Hilltop Circle Baltimore, MD 21250
Tel: 410-455-3394
Fax: 410-455-1052
wzhu@umbc.edu

3. PRESENTATIONS

1. Workshop Agenda

M. J. Starr

**Third International Workshop on Joint
Mechanics
August 16 – 17, 2012
Hyatt Regency, McCormick Place
Chicago, Ill, USA**

Workshop Agenda

Thursday, August 16th, 2012

Location: Hyatt Regency Hotel, McCormick Place, Meeting Suite 4

- 0900 Welcome and introduction to the workshop
- 0915 Introduction of all participants
- 0930 Review of Workshop 2 outcomes – Actions and Challenges

- 1030 Coffee

- 1045 Post Workshop 2 activities, continued
- 1115 Report on ASME Research Committee, including mission, membership, and subcommittees
- 1200 Overview of Workshop 3 Objectives

- 1215 Lunch

Workshop Agenda

Thursday, August 16th, 2012

Location: Hyatt Regency Hotel, McCormick Place, Meeting Suite 4

1330 Presentations and Discussion of Strategic Themes

Objectives: to identify the major research themes for the next 5-10 years and the groups and networks pursuing them; to define format for Workshop 3 Road Map

- Fatigue and Contact Mechanics (David Hills and David Nowell)
- Physics-based/data driven modeling (Melih Eriten)
- View from Germany (Lothar Gaul and Bernhard Stingl)
- Flight systems/satellites/weapons (AWE/Sandia)
- Vibrations/Turbine engines (Muzio Gola and Christoph Schwingshackl)
- Uncertainty Approaches to Joints and Interfaces (Marc Mignolet)
- Institutional Structure and Vision (Alex Vakakis)

1630 Review outcome of Day 1 discussions and Agenda for Day 2

1700 Close

Workshop Agenda

Friday, August 17th, 2012

0830 Review plan for Day 2 and specific target(s)

0850 Define major application needs/current and proposed research themes/research groups and networks

1015 Coffee

1030 Define Actions & Challenges 2012

1130 Assignments of tasks for implementation of Actions and Challenges 2012

1230 Close

2. Introduction

M. J. Starr

Third International Workshop on Jointed Structures

**16 – 17 August, 2012
Hyatt Regency, McCormick Place
Chicago, Ill, USA**

An Introduction

Outcomes of the First Workshop

Arlington, Virginia, 16-18 October, 2006

This workshop attempted to identify each of the component technologies that touch on dynamics of jointed structures and then to draw the relevant connections among those technologies.

- Relevant phenomena span scales from nanometers to the lengths of structures. A significant conclusion at the end of that workshop was that the range of length scales and the physics and chemistry that dominate at each scale made it unlikely that those scales could be coupled in a rigorous manner in the near future.
- This conclusion was first prompted by the observation that participants could address modeling issues either at the extremely small scales (atomistic-nano) or scales moderately large (asperity and up), but there were no clear strategies to bridge those scales. The difficulty seems to be that analysis at each scale requires consideration of physics and chemistry that dominate at that scale and that there are many discretely defined scales between the small and large scales that remain to be addressed.

Outcomes of the Second Workshop

Dartington Hall, Totnes, Devon, UK, 26 -29 April, 2009

This workshop emphasized topics more on the macro- and meso-scales, where coupling through the relevant length scales becomes more tractable. Focus on these larger length scales resulted in identification of several core issues and the development of strategies to address them.

Consistent with the above, invited talks and breakout sessions focused on the following themes:

- **Theme A** concerns the engineering end-user needs for better predictive models of joints. It concerns the need for better understanding and theoretical modelling of the various friction phenomena which ultimately determine the mechanical characteristics of so many joints in engineering structures of all types. It also concerns the potential future benefits that might result from an improved prediction capability, such as the design of much more effective joints, and much more repeatable ones.

Outcomes of the Second Workshop

Dartington Hall, Totnes, Devon, UK, 26 -29 April, 2009

- **Theme B** represents a critical and comprehensive assessment of our current capabilities in this general area. Theoretical, numerical and experimental techniques allow us a degree of control over the joints that we design and use today, but they are still far from ideal, or from the levels of predictability that apply to the components which are assembled by using the joints of current interest.
- **Theme C** includes the various recent developments and ideas for future methods which will eventually allow us to deliver the predictive modelling and design capabilities to make the joints of the future exactly what we want them to be: repeatable, efficient, with stiffness and damping performance characteristics as desired to optimize the dynamics of the structure of which they form part.

3. Actions and Challenges from the 2009 Workshop

M. J. Starr

Third International Workshop on Jointed Structures

**16 – 17 August, 2012
Hyatt Regency, McCormick Place
Chicago, Ill, USA**

Actions and Challenges, 2009

Actions and Challenges, 2009

During the last session of the Workshop, there was a discussion seeking to distill the essential issues and topics which would emerge as the main items defining the new Road Map for the subject. The resulting list divides into 2 sets – Actions and Challenges.

The Actions are tasks that are essentially short-term goals deemed to be necessary in order to consolidate the foundations of the subject to provide a sound basis for further research.

The Challenges are much more substantial tasks, each requiring several man-years of research effort, whose objectives are to move the whole subject on to a new level of technical competence, heading to the ultimate goals of the ability to model, and to predict the dynamics of mechanical joints and thereby to design structures with optimum dynamic properties – including those whose dynamics are actively controlled by the joints themselves.

In many cases, offers of leadership of the tasks were recorded as were expressions of interest in participation.

Actions, 2009

1. Terminology & Vocabulary (*Segalman; Bergman*)
2. Develop Hills Chart (*Dini; Berger*)
3. Classification of Standard Joint Types (*Hills; Vakakis; Starr*)
4. Classification/Cataloging of
 - (a) Non Linearity ID Methods (*Vakakis*)
 - (b) Modelling approaches (*Polycarpou; Quinn*)
 - (c) Measurement methods (*Nowell; Bergman; Akay*)
5. Benchmark current computation multi-scale methods against analytic solutions (*Masud; Laursen; Quinn*)
6. Create a formal Joints Modelling Network (or Community) with more frequent and regular contacts (this was expressed emphatically); meetings at relevant conferences; workshop series;... Wiki..Joints Chat room (*Ewins; Segalman; Nowell; Bergman; Gaul; Green; Surampudi; Dini; Quinn*)

Challenges, 2009

1. Round Robin/Benchmark Exercise for Hysteresis Measurements (*Ewins; Nowell; Gola; Polycarpou; + possibly Epsilon(Technion)*)
2. Round Robin/Benchmark for Measurement/Prediction of Dissipation in Standard Joints (*Leming; Goyder; Gaul; Ind; Vakakis*)
3. Repeatability (measurement-to-measurement) and Variability (unit-to- unit) Issue: need to be able to distinguish between, and to greatly improve performance in both aspects (i.e. design of better, more repeatable joints) (*Leming; Goyder; Gaul; Ind; Polycarpou; Farris; Mignolet*)
4. Framework for Multi-Scale Modelling (*Masud; Dini; Nowell*)

Actions and Challenges Results

Action 1

Terminology and Vocabulary

1. States of slip

- (a) **Macro-slip**: the situation that exists when loads on a joint cause all of the contact patch to be in a state of slip.
- (b) **Partial-slip**: the situation that exists when loads on a joint cause some, but not all, of the contact patch to be in a state of slip.
- (c) **Micro-slip**: the situation that exists when loads on a joint cause a small fraction ($<1/1000$) of the contact patch to be in a state of slip.
Alternatively, the situation that exists when loads on a joint cause such a small fraction of the contact patch to be in a state of slip that the interface stiffness is independent of load.

2. Resonance Tests

- (a) **Forced Resonance Testing**: experiments where a dynamic system including a jointed specimen is driven by a steady (or quasi-steady) oscillatory force.

Action 1

Terminology and Vocabulary

2. Resonance Tests, cont'd

(b) **Ring-Down Testing:** experiments where a dynamic system including a jointed specimen is subject to transient initial conditions and data is collected from subsequent decaying signal.

3. Quasi-static Tests

(a) **Ratchet-Testing:**

(b) **Break-Free Testing:** dynamic or quasi-static tests designed to identify the force necessary to initiate macro-slip.

4. Scales

(a) **Nano-scale:** referring to structures or mechanisms that occur on length scales of 1-100 nanometers.

Action 1

Terminology and Vocabulary

4. Scales, cont'd

(b) **Micro-scale:** referring to structures or mechanisms that occur on length scales of 1-100 microns. *Alternatively*, referring to structures or mechanisms that take in regions of a problem that are on the order of 1/1000th of the dimension of the overall problem. Generally, an analysis which involves many degrees over a contact patch will be considered a micro-scale investigation.

(c) **Meso-scale:** the length scale of the contact patch.

(d) **Macro-scale:** The length scale of the full structure.

Action 2

"Hills" Chart

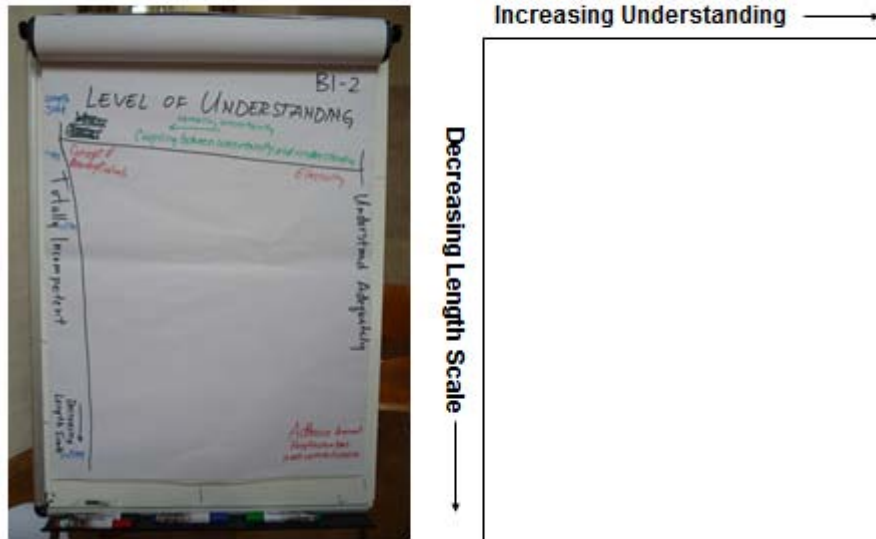

Action 3

Classification of Standard Joint Types

1. Contact Classification

The two most frequently occurring joints in a classical categorisation are 'incomplete' and 'complete', which have the following relevant characteristics:

Incomplete contacts. At least one of the two bodies is convex, and the contact patch is usually small compared with the radius of curvature. The contact pressure falls smoothly to zero at the contact edges and, in almost cases a 'half-plane' formulation may be used. If, in addition, the bodies are made from the same material, the normal and shear aspects of loading are uncoupled, so that shearing effects do not modify the contact pressure distribution and vice versa. Equally, because the contact pressure falls to zero at the edges, there can be no residual interfacial shear stress adjacent to the edges so that the contact cannot, except for special proportional-loading trajectories, achieve a frictional fully shaken down state (the 'shakedown limit' is formally zero load). It follows that all incomplete contacts subject to oscillatory shear will dissipate frictional energy, although the steady state dissipation will usually be smaller than the initial transient quarter cycle, because some residual shearing tractions will develop and hence the steady-state stick zone size will normally be bigger than the initial one. In principal, there could exist incomplete contact problems where half-plane (space) theory will not apply. These will be coupled unless the domains constituting the two bodies are the same, as well as being made from the same material. One can conceive of certain exceptions to these guidelines; for example, if we have torsional contact between, say, a spherical component and a flat, they would not need to be made from the same material to maintain a lack of coupling, because the effect of 'shear' (torsion) would be to induce only a theta-direction displacement.

Action 3

Classification of Standard Joint Types

1. Contact Classification, cont'd

Complete contacts. These have the characteristic that the edges of the contact are defined by a discontinuity in the surface profile gradient. This makes it impossible to use a half-plane formulation, and therefore to obtain a fully analytical solution to the problem. Usually one would use the finite element method (or perhaps the BEM) to solve the contact problem, but recently, we have had a lot of success in using wedge theory to sort out what happens at the contact edges which are often of the most relevance. This 'eigenfunction expansion' imposes a lot of conditions on what might possibly arise at the edges and can establish the coefficient of friction for the avoidance of all slip analytically, even in the absence of a full numerical solution. Importantly, in most circumstances the contact faces remain pressed together over their entire length throughout the history, and hence a fully shaken down frictionally adhered state may be achieved. Further, because the domains of the two bodies are different there is always coupling between normal and shear loading. Barber has recently shown that this means that the Melan shakedown theorem cannot be applied [We usually think of Melan's theorem as implying 'If it can shake down, it will', but in the case of these contacts Barber's work simply says that 'If it can shake down, it might'. What determines whether it will or not is going to depend on the nature of any pre-existing residual stresses and therefore on things like bolt-tightening sequences or manufacturing errors. This is yet to be studied in detail, and systematic studies of example problems are needed].

Action 3

Classification of Standard Joint Types

1. Contact Classification, cont'd

These are not the only kinds of contacts, but the nomenclature for the others is not fully refined. 'Receding' contacts were first studied by Dundurs thirty years ago and arise typically when a punch is pressed into a relatively thin plate. They are therefore very relevant to lap joints with clamped, bolted fixings. They have the characteristic that the contact, at the lightest loads, 'jumps' to a much smaller value than the initial one. They are certainly usually coupled (although maybe in some symmetrical configurations this may be absent) which has implications for the application of Melan's theorem, but they have not been extensively investigated. It was noted, more recently, that there are other kinds of contacts which do not 'jump' but recede monotonically with increasing load – for example an over-sized disk in a hole – but this may have limited relevance to joints.

There is a further kind of contact we have started to look at recently, which may have some relevance – this is when the contact patch is defined by **both** bodies. For example, when two semi-infinite strips are pressed together end-to-end (this is not unlike two symmetrical flanges of the same size). Here, our very preliminary investigations have shown that the application of a shearing force causes slip to initiate from an interior point and progress towards the edges. On the other hand, if two semi-infinite cylinders of the same radius are pressed end-to-end and twisted, slip starts at the outside first and progresses inwards. These are still very preliminary investigations.

Action 3

Classification of Standard Joint Types

1. Contact Classification, cont'd

General remarks. The most important aspect of these classes of contact of relevance to our current concerns is the repeatability of the behaviour of the contact. It is useful to know that uncoupled contacts are expected to show repeatability because Melan's theorem does apply – although, it does not, of course, follow that all uncoupled contacts will shake down. In fact, that is extremely unlikely for the reasons set out earlier, but their behaviour is likely to be consistent, and this is experimentally observed. They do 'shake down' but not to a fully adhered state – only to one in which the stick zone is stable in size and independent of any initial disturbances. On the other hand, we now have good grounds for believing that coupled contact problems will not, generally, obey the Melan theorem, and this could explain the observed lack of repeatability. Very small differences in an assembly – order to tightening of bolts, manufacturing differences – which have no **visible** effect may modify significantly the starting point for the development of residual shearing tractions and hence, also, the end point.

2. Joint Classification

In perhaps the majority of designed engineering interfaces (especially those for structural applications), the transfer of loads from adjacent components occurs across conformal interfaces. Two major subclasses of conformal engineering joints are described below:

Lap Joint. A joint created by overlapping two or more pieces of material. The bond on the connecting interface may be made with an adhesive or weld to create a nominally continuous interface or through a means of clamping the individual pieces together with a bolt or other attachment which uses a preload to limit the relative displacement of the contacting interfaces.

Action 3

Classification of Standard Joint Types

2. Joint Classification, cont'd

However, under the consideration of surface features and microscopic details, the local regions of true contact should be considered to be of the 'incomplete' type of contact. The most common modes of attaching the lapped materials are through an adhesive layer, by welding, or through a bolted connection. It is typically assumed that the use of adhesive layers and welds provides a continuous interface between the two joined materials, but there exists ample evidence that incomplete bonding and crack growth lead to nonlinear response of the interface when subjected to dynamic loading. The attachment mode of great interest in structural dynamics applications is that of the bolted joint, which appears in numerous different configurations such as the discrete single bolt attachment or the distributed bolted flange ring. The response of the bolted lap joint can further be parameterized in many ways, including: thickness of connected flanges, use of washers, bolt preload, etc.

Distributed Circumferential Contact. This joint is designed to connect two or more pieces of material. The interface is designed to employ the interlocking of continuous surfaces to clamp opposing contacting interfaces together. The interlocking may take the form of a rotated continuous inclined plane (such as a screw thread), or opposing inclined planes (such as a tape joint to connect axisymmetric shells) and relies on interference and friction to maintain contact. This type of engineering interface can be considered to be of the 'complete' type. These type of connections are designed to be extremely stiff in the axial direction, as this direction is aligned with the normal to contact or interference. However, the tape joint, in particular, may be susceptible to failure when subjected to oblique loading.

There are many other types of engineering joints that do not fall under the conformal classification. These joints/interfaces are often used to enable linear or rotational motion such as races and bearings, which should be considered a 'complete' kind of contact.

Action 4

Classification/Cataloging of Modeling Methods and Approaches

Action 5

Benchmark Multi-Scale Methods against Analytic Solutions

Remarks on Computational Simulations of Mechanical Joints

- Two major approaches for simulating mechanical joints are being pursued by the engineering community: molecular dynamics and quasicontinuum.
- Atomistic calculations can reproduce the local physical processes of contacting interfaces at the nanoscale quite well, and simulations correlate well with experiments [14,9].
- However, molecular dynamics simulations can only be scaled up about three to four orders of magnitude, making structural-level calculations on current computing platforms impossible.
- Techniques to couple molecular dynamics and continuum level formulations are currently under investigation and are not without major hurdles [13].
- Quasicontinuum approaches are the more well-established alternative that seek to account for microscale behavior through effective constituent modeling [12].

Action 5

Benchmark Multi-Scale Methods against Analytic Solutions

Remarks on Computational Simulations of Mechanical Joints

- Using the finite element method as the continuum approach, various constitutive models for contacting surfaces have been incorporated to some degree of success [3,2].
- Finite element techniques traditionally rely on springs, node-to-surface projection, or mortar methods to treat the discrete contact conditions; only the latter have made significant in removing mesh biasing and solving finite strain problems consistently [7,8].
- The approach adopted by Masud and coworkers utilizes the Discontinuous Galerkin method to enforce the contact constraints, which provides consistent numerical flux terms in which constitutive interface models can be embedded [5, 10].
- The physics-based models for friction embedded in the Discontinuous Galerkin formulation are derived from a statistical approach that accounts for local mechanical/material properties to avoid ad-hoc tuning coefficients [10]; further refinements on the models allow for a problem-dependent coefficient of friction [1].

Action 5

Benchmark Multi-Scale Methods against Analytic Solutions

Remarks on Computational Simulations of Mechanical Joints

- The computational formulation is enhanced by the Variational Multiscale method, which provides stability to the domain and contacting interfaces as well as a mechanism for estimating the discretization error in computed solutions [6]; accurate estimations of error distribution provide a measure of confidence in the results.
- Although not pursued in the current work, the Variational Multiscale method can serve as a platform for bridging physical scales, such as the modeling of microstructural defects within a macroscale continuum model [4].
- The robustness of the Discontinuous Galerkin method for solving dynamic friction problem is currently under investigation [11].
- Based on current trends, quasicontinuum approaches show greater promise of accurately embedding micromechanical frictional behavior into structural system models.

Action 5

Benchmark Multi-Scale Methods against Analytic Solutions

References

- M. Eriten, A.A. Polycarpou, L.A. Bergman, Physics-based modeling for fretting behavior of nominally flat rough surfaces, *International Journal of Solid and Structures* 48 (2011) 1436–1450.
- J. Haslinger, O. Vlach, Approximation and numerical realization of 2D contact problems with Coulomb friction and a solution-dependent coefficient of friction, *Journal of Computational and Applied Mathematics* 197 (2006) 421–436.
- P. Ladeveze, A. Nouy, O. Loiseau, A multiscale computational approach for contact problems, *Computer Methods in Applied Mechanics and Engineering* 191 (2002) 4869–4891.
- A. Masud, R. Kannan, A multiscale framework for computational nanomechanics: Application to carbon nanotubes, *International Journal for Numerical Methods in Engineering*. 78 (2009) 863–882.
- A. Masud, T. Truster, L. Bergman, A unified formulation for interface coupling and frictional contact modeling with embedded error estimation, *International Journal for Numerical Methods in Engineering*. (2012) doi:10.1002/nme.4326

Action 5

Benchmark Multi-Scale Methods against Analytic Solutions

6. A. Masud, T. Truster, L.A. Bergman, A variational multiscale a-posteriori error estimation method for mixed-form of nearly incompressible elasticity, *Computer Methods in Applied Mechanics and Engineering*. 200 (2011) 3453–3481.
7. T.W. McDevitt, T.A. Laursen, A mortar-finite element formulation for frictional contact problems, *International Journal for Numerical Methods in Engineering*. 48 (2000) 1525–1547.
8. M.A. Puso, T.A. Laursen, A mortar segment-to-segment contact method for large deformation solid mechanics, *Computer Methods in Applied Mechanics and Engineering*. 193 (2004) 601–629.
9. M. Solar, H. Meyer, C. Gauthier, O. Benzerara, H. Pelletier, R. Schirrer, J. Baschnagel, Molecular dynamics simulations as a way to investigate the local physics of contact mechanics: A comparison between experimental data and numerical results, *Journal of Physics D: Applied Physics*. 43 (2010) 455406
10. T. Truster, M. Eriten, A. Polycarpou, L. Bergman, A. Masud, A new computational method for mechanical joints: Physics-based models and variationally consistent embedding, *International Journal of Solids and Structures*, submitted.

Action 5

Benchmark Multi-Scale Methods against Analytic Solutions

11. T. Truster, A. Masud, L. Bergman, Variational formulation for frictional interface dynamics, Proceedings of the ASME 2012 International Design Engineering Technical Conferences & Computers and Information in Engineering Conference IDETC/CIE 2012, August 12-15, 2012, Chicago, IL, USA.
12. E.B. Tadmor, M. Ortiz, R. Phillips, Quasicontinuum analysis of defects in solids, Philosophical Magazine A. 73 (1996) 1529–1563.
13. E. Weinan, B. Engquist, X. Li, W. Ren, E. Vanden-Eijnden, Heterogeneous multiscale methods: A review, Communications in Computational Physics. 2 (2007) 367–450.
14. Y.Y. Ye, R. Biswas, J.R. Morris, A. Bastawros, AChandra, Molecular dynamics simulation of nanoscale machining of copper, Nanotechnology. 14 (2003) 390–396.

Action 6

Joints Modeling Network

4. Strategic Themes

M. J. Starr

Third International Workshop on Jointed Structures

16 – 17 August, 2012
Hyatt Regency, McCormick Place
Chicago, Ill, USA

Strategic Themes

Strategic Themes

Objectives: to identify the major research themes for the next 5-10 years

Brief introductory remarks (10-15 minutes) on your research focus area. We would like to initiate discussion related to your focus area while addressing the overarching question: How does this area fit into the larger research community? It is desired that your prepared remarks be more than simply addressing your current research, but should be strategic in content. For instance: enumeration of what we cannot now do well with respect to joints. Some basic questions that you might consider discussing are:

1. What are the important problems in your area?
2. How do you decide which problems you take on?
3. Who will be the end user of the results of your work?
4. How do you get funding?

10-15 minute group discussion about this topic area. **After discussion, for tomorrow's activities focus area presenter is asked to produce list of three most important elements (short and long term) to make progress in your focus area.**

Strategic Themes

Objectives: to identify the major research themes for the next 5-10 years

- Institutional Structure and Vision (Alex Vakakis)
- Fatigue and Contact Mechanics (David Hills and David Nowell)
- Physics-based/data driven modeling (Melih Eriten)
- View from Germany (Lothar Gaul and Bernhard Stingl)
- Flight systems/satellites/weapons (AWE/Sandia)
- Vibrations/Turbine engines (Muzio Gola and Christoph Schwingshackl)
- Uncertainty Approaches to Joints and Interfaces (Marc Mignolet)

5. The ASME Research Committee on the Mechanics of Jointed Structures

Third International Workshop on Jointed Structures

**16 – 17 August, 2012
Hyatt Regency, McCormick Place
Chicago, Ill, USA**

**ASME Research Committee on the
Mechanics of Jointed Structures**

ASME Research Committee on the Mechanics of Jointed Structures

One particular Action 6 has resulted in a well received proposal to create an Research Group within the ASME Board on Research and Technology Development (BRTD).

The purpose of this group is:

1. to facilitate inter-institutional and international collaboration in joints research efforts.
2. to promote standardization of nomenclature and procedures where it could be found helpful.
3. to author and edit publications that advance the understanding of joints mechanics issues.
4. to advance research into joint mechanics and dynamics of jointed structures by development of a joints handbook. This handbook would be built through the selection of authors and editors to contribute to the revision of the Sandia Joints Handbook to be something of continuing and broad utility.

The ASME BRTD has approved such an ad hoc committee for the above purposes and will consider a sustaining Joints Research Committee when it meets in June 2010.

ASME Research Committee on the Mechanics of Jointed Structures

Activities and Directives

At a minimum the committee will establish a website through ASME that will allow all interested committee members (emeritus, regular, and associate) access to documents and information related to the committee. The information available includes, but is not limited to: meeting minutes, proceedings, monographs, handbooks, details about organized seminars, workshops, symposia, and conferences. It was suggested that **Ed Berger** be involved in administration of such a site.

The following subcommittees have been established: Administrative, Events, and Publications.

The **Administrative Subcommittee** will be populated by the committee officers and may also include a representative from AWE (e.g. **Phil Ind**).

ASME Research Committee on the Mechanics of Jointed Structures

Activities and Directives

The **Events Subcommittee** will be chaired by **Dane Quinn**. It is proposed that other members of the subcommittee will be **Daniele Dini** and **Andreas Polycarpou**.

The **Publications Subcommittee** will be chaired by **Dan Segalman**. It is proposed that **Ed Berger** and **Arif Masud** also be invited to be members of the subcommittee.

The **Events Subcommittee** has organized symposia at the following conferences:

McMAT, Chicago, June, 2011
IJTC, Los Angeles, October, 2011
IDETC, Washington, D.C., August 2011
IDETC, Chicago, August 2012

ASME Research Committee on the Mechanics of Jointed Structures

What is the best way to use the ASME connection?

Upcoming Conference Schedule

	2012	2013	2014	2015
IDETC		Portland 4 – 7 Aug	Toronto	Rome
IMECE	Houston 9 – 15 Nov	San Diego 15 -21 Nov	Montreal	
Applied Mechanics Division	Beijing 19 – 24 Aug			
Turbo Expo		San Antonio 3 – 7 June	Dusseldorf 16 – 20 June	Montreal 15 – 19 June
STLE/IJTC	Denver 7 – 10 Oct			
IMAC		Garden Grove, CA 11 – 14 Feb	Orlando, FL 3 – 6 Feb	
SEM		Lombard, IL 3 – 6 June	Greenville, SC 2 – 4 June	

Which conferences are you likely to attend?

6. The Joints Handbook

M.J. Starr

Exceptional service in the national interest



Sandia
National
Laboratories

Photos placed in horizontal position
with a vast amount of white space
between photos and header

The MJS Research Committee

Joints Handbook

Presented to the ASME Research Committee on
Mechanics of Jointed Structures, 2012 Workshop Chicago



ENERGY



NNSA

Sandia National Laboratories is a multi-program laboratory managed and operated by Sandia Corporation, a wholly owned subsidiary of Lockheed Martin Corporation, for the U.S. Department of Energy's National Nuclear Security Administration under contract DE-AC02-04-OR21400.

Goals



- Document current state of understanding and practice
- Facilitate standardization of practice in measurement and calculation.
- Provide gateway into joints research, design, measurement, ...
- Help establish our committee as the key world-wide recourse in this topic

2

About Sandia's Joints Handbook



- Currently freely available
 - http://www.osti.gov/bridge/product.biblio.jsp?query_id=0&page=0&osti_id=1028891&Row=10&formname=basicsearch.jsp
 - http://www.imperial.ac.uk/workspace/medynamics/public/JointsC6H_andbook3bUU.pdf
- Has serious limitations
 - Focus is primarily on Sandia's interests – parochial
 - Narrow, generally presents only one view on each aspect of problem (constitutive modeling, finite element analysis, testing,
 - Rapidly getting out of date
 - No SNL plan for sustainment
 - Little audience appeal

3

Strategy



1. Employ ASME's interest in publishing such a document
2. Build on Sandia's own joints handbook – if only as goal.
3. Develop a editorial board
4. Recruit authors

4

Strategy – Element 1



- Employ ASME's publications department.
 - They publish a number of handbooks
 - Have a recognized brand
 - They have expressed interest in publishing a handbook from us

5

Strategy – Element 2



- Build on Sandia's own joints handbook – if only as goal
 - Employ, modify, and expand structure
 - Create more balanced presentation
 - Rewrite, expand, or replace existing chapters
 - Develop chapters on important topics neglected by SNL handbook

6

Strategy – Element 3



- Editorial Board
 - Populated by experts in each aspect of jointed structures
 - Interphase mechanics
 - Constitutive modeling
 - Experimental methods
 - Structural dynamics, Modal analysis
 - Nonlinear signal processing
 - Recognized as an official component of this ASME Research Committee

7

Strategy – Element 4



- Authors
 - Members of this committee
 - Nonmembers who would like to be honored by invitation to write a chapter

8

Timetable



- Let's try to assemble the editorial board before next year's meeting

9

Appendix



- Table of contents of the Sandia Joints Handbook

10

Your tracking number is: 5311332

Submission Details	
Document Info	
Title : The MJS Research Committee Joints Handbook	
Document Number : 5311332	SAND Number : 2012-6444 C
Review Type : Electronic	Status : Approved
Sandia Contact : Segalman, Daniel J.	Submital Type : Conference Paper
Requestor : Segalman, Daniel J.	Submit Date : 08/01/2012
Comments : This will be a report to the ASME Research Committee on Mechanics of Jointed Structures on the process of extending the Sandia joints handbook (released as UUR in 2010) into an ASME book.	
Peer Reviewed? : No	Prog. Review? : No
Author(s)	
Segalman, Daniel J.	
Event (Conference/Journal/Book) Info	
Name : Meeting of the ASME Research Committee on Mechanics of Jointed Structures.	
City : Chicago	State : IL Country : USA
Start Date : 08/16/2012	End Date : 08/17/2012
Partnership Info	
Partnership Involved : No	Agreement Number :
Patent Info	
Scientific or Technical in Content : No	TA Form Filed : No
Technical Advance : No	SD Number :
Classification and Sensitivity Info	
Title : Unclassified	Abstract : Document : Unclassified
Additional Limited Release Info : None.	
DUSA : None.	



Routing Details			
Role	Routed To	Approved By	Approval Date
Derivative Classifier Approver	Choss, Michael L.	Choss, Michael L.	08/02/2012
Conditions:			
Classification Approver	Carter, Winston E.	Hatheway III, Edward L.	08/02/2012
Conditions:			
Manager Approver	Choss, Michael L.	Auto-Approved	08/02/2012
Conditions:			
Administrator Approver	Collops, Laura	Auto-Approved	08/02/2012
Automatic closure of a request approved with no conditions.			

11

7. Institutional Structure and Vision

A. Vakakis

Institutional Structure and Vision

Alexander F. Vakakis
Linear and Nonlinear Dynamics and Vibrations Laboratory
Department of Mechanical Science and Engineering
University of Illinois at Urbana – Champaign
www.lndvl.mechse.illinois.edu



0

Mechanical Joints: Unique Research Topic

- Of interest to Academe
- Of interest to Government
- Of interest to Industry

Hence, unique opportunity to work together in a very complex set of problems both in basic and applied research.

In the process educate graduate and undergraduate students, produce papers, address and provide solutions to some of Industry's problems, address some of Government's needs, promote mechanical joints research as an important topic of research for society



1

Mechanical Joints: Need (Sustained) Funding...

- To succeed in this undertaking we need funding
- Fact of life: Otherwise, despite of our good intentions, for many of us this research might not be a first priority
- The Institutional Structure should facilitate this
- We need to find ways to propose a long-term, flexible research plan that could initiate a dialog



2

Mechanical Joints: Need (Sustained) Funding...

- Personal ideas:
 - Start by defining a set of benchmark computational and experimental benchmark problems with the goal to involve Academe/National Labs/Funding Agencies/Industrial Partners in a common effort → Define these problems together with industry and seek Industry's help in promoting them
 - This will provide a set of 'real', interesting and difficult problems with the potential to drastically extend the state-of-the-art in mechanical joints over span different scales
 - This will challenge us to work together, form teams to address these problems from different perspectives (instead of working in isolation) towards a common goal
 - With good future potential this might become a top priority for many of us and might form an interesting new paradigm for research collaboration between A/G/I
 - 'Show what we can do' and then proceed from there...



3

8. Fatigue and Contact Mechanics

D. Hills and D. Nowell



Measurement and modelling of contact stiffness

D. Nowell, University of Oxford, UK

Joints workshop, Chicago, 16/8/12



Difficulties in modelling contacts

- In general, the normal and tangential stiffnesses need to be experimentally measured, along with the friction coefficient
- These properties may change with time (e.g. as the contact wears, with position, and with load)
- Progress is needed towards a model of interface behaviour, which is based on more fundamental properties (material properties, surface geometry etc).
 - We also need to understand how to incorporate the interface behaviour into global (FE) models of the system



Measurement of Contact behaviour – Oxford and Imperial rigs

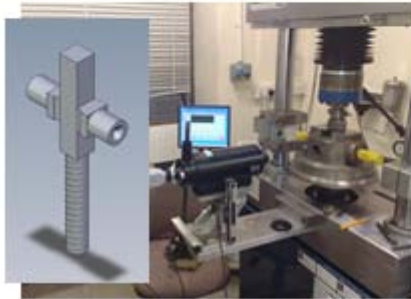

- 80 mm² flat and rounded contact
- 1Hz Frequency
- 0.6mm sliding distance
- Displacement measurement by remote LVDT or digital image correlation

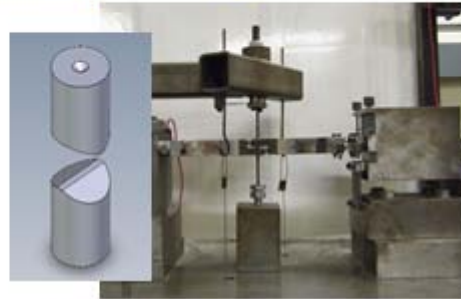

- 1 mm² flat on flat contact
- ~100Hz Frequency
- 30µm sliding distance
- Displacement measurement integration of LDV measurements



Measured and idealised hysteresis loops



- Idealised loop is characterised by contact stiffness, k and friction coefficient, μ
- These can be reasonably representative of real loops

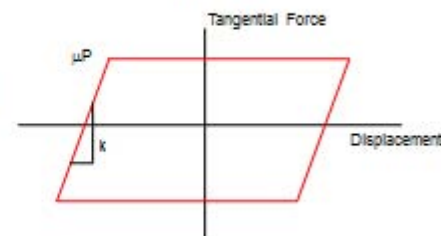
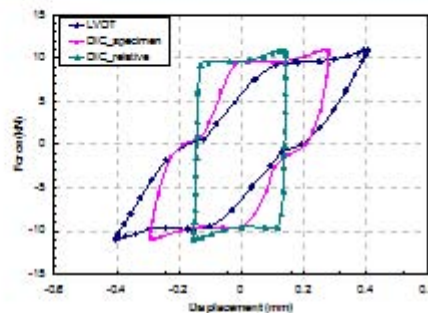



Variation of contact stiffness with measurement location

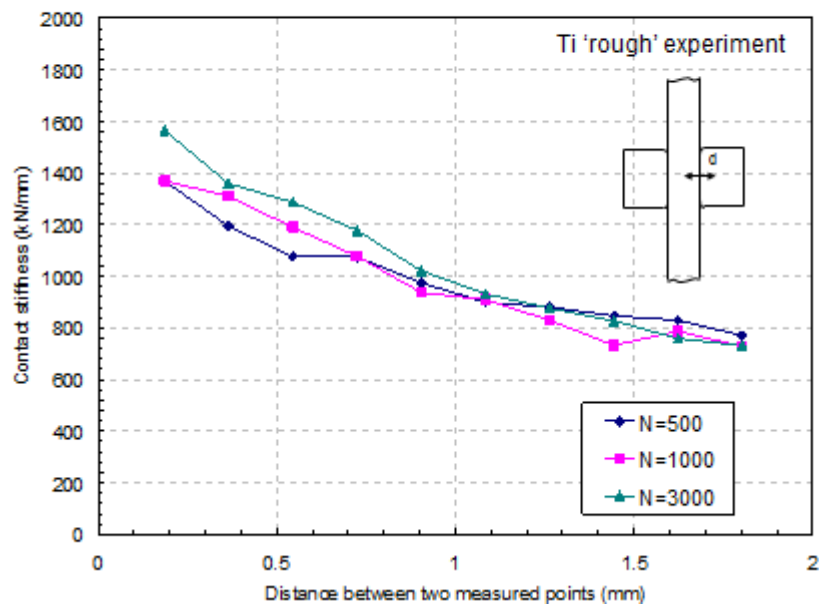

Predicted (FE) variation of tangential stiffness

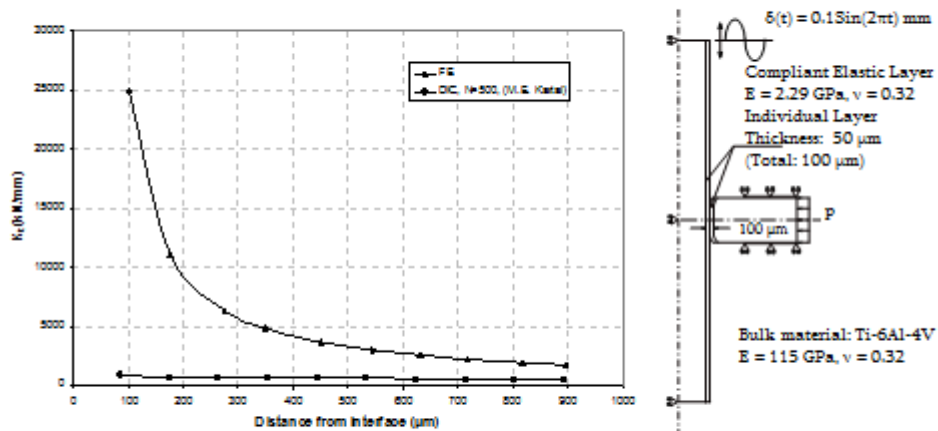

FE predictions of stiffness based on smooth contact are much higher than experimental measurements



Modelling - basic assumptions

- To develop a model for contact stiffness, we need consider surface roughness
- Initial tangential loading is likely to be predominantly elastic
- Consider a rough elastic surface in contact with a smooth rigid one. This puts all the elasticity and roughness on one surface and is easier to deal with
- At light loads, 'asperity' contacts will be relatively widely-spaced and may be modelled as Hertzian

$$p(r) = p_0 \sqrt{1 - \left(\frac{r}{a}\right)^2}$$



Formulation

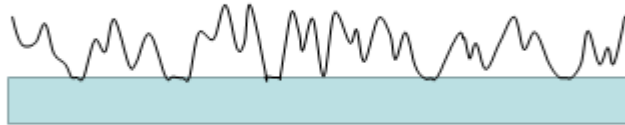

- When tangentially loaded, all contacts will initially be 'stuck', so the shear traction at each contact will be given by

$$q(r) = \frac{q_0}{\sqrt{1 - \left(\frac{r}{a_i}\right)^2}}$$

- Mindlin gives the compliance for this traction distribution as $\frac{1}{\kappa_i} = \frac{\Delta}{Q_i} = \frac{1}{8a_i} \left(\frac{2-\nu}{G} \right) = \frac{1}{4a_i} \left(\frac{(1+\nu)(2-\nu)}{E} \right)$
- From this, the Greenwood/Williamson approach can be used to derive an expression for tangential stiffness



Result

- The approach leads to

$$\kappa^T = \frac{2(1-\nu)P}{(2-\nu)\sigma}$$

- Note that this is independent of Young's modulus
- This is consistent with the results of Berthoud and Baumberger (1997), who found limited effect of modulus and

$$\kappa = \frac{P}{\lambda}$$

- Where λ is a length scale of the order of microns (i.e. similar to σ)
- Normalisation by area gives

$$\frac{\kappa^T}{A_a} = \frac{2(1-\nu)\bar{p}}{(2-\nu)\sigma} = 0.82 \frac{\bar{p}}{\sigma} \quad \text{for } \nu = 0.3$$



Area effect

Effect of contact area on tangential contact stiffness for 70 MPa average pressure

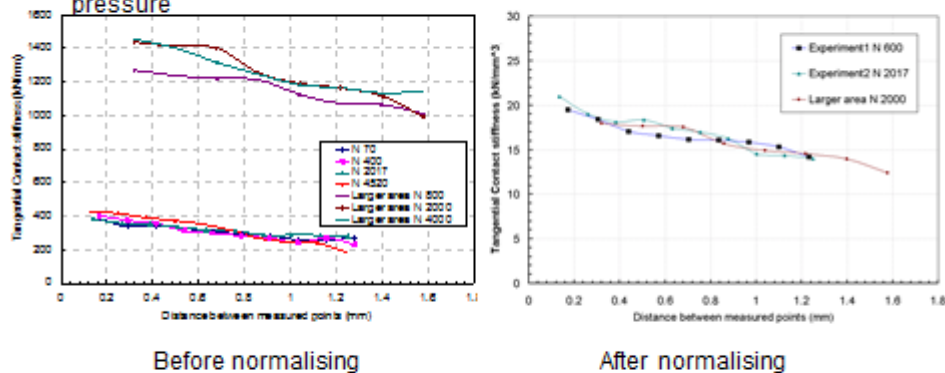

Experiments carried out with different contact area do suggest that stiffness is approximately proportional to apparent area of contact

This is because almost all of the compliance is in the surface layer



Effect of normal load

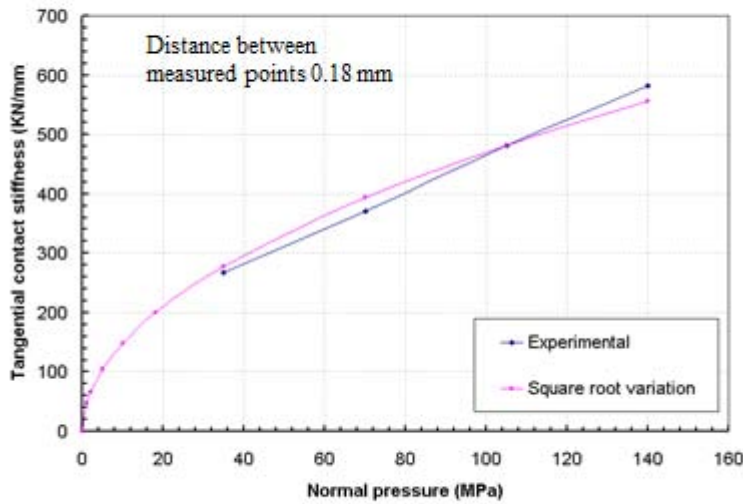

Effect of normal pressure on tangential contact stiffness, N=20-25 cycles



Comparison with numerical model

- As part of our joint project with Imperial College, Medina has produced a numerical model of rough elastic contact
- Comparison shows good agreement at low loads, but reduced stiffness in numerical model at higher loads
- Effect is almost certainly caused by asperity interaction
- Similar effect noted for normal contact by Ciavarella et al (2008)

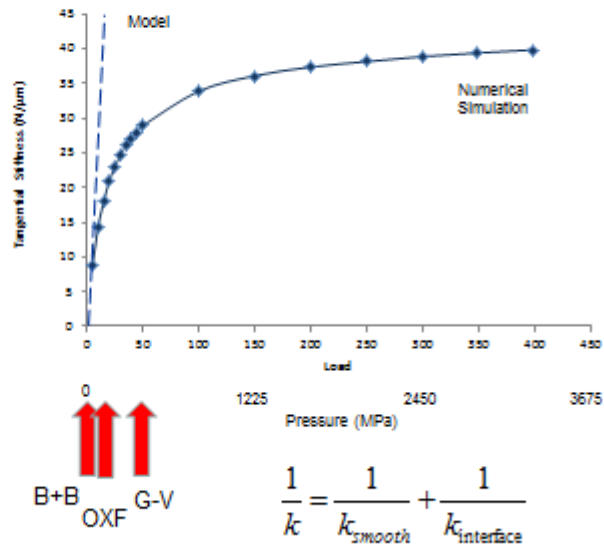



Comparison with ultrasound measurements

- Recent work in collaboration with Sheffield Univ has compared stiffness measured with DIC with that using ultrasound

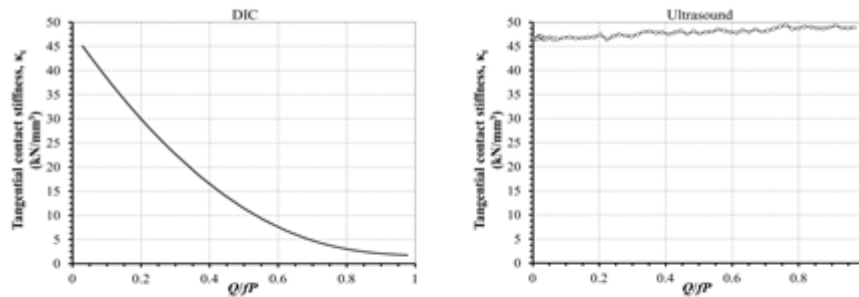

- Note that (in this case) initial value is very similar, but variation with Q is very different
- Ultrasound is measuring an unloading stiffness



Ultrasound measurement

- Ultrasound measures an unloading stiffness:

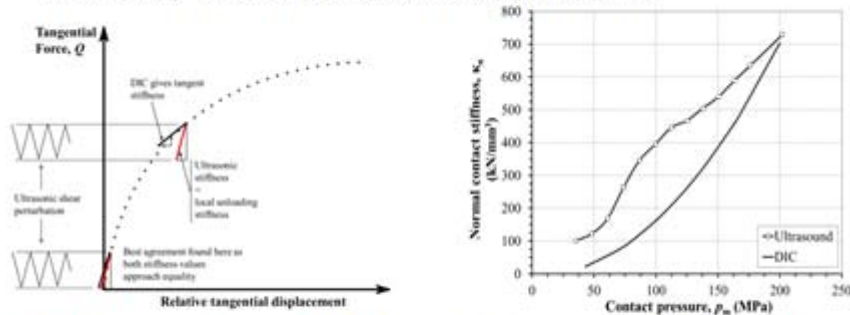

- In the case of normal stiffness, there is a similar effect, in this case there is an increase of stiffness with (normal) load and growth of the real contact area



Perspectives

- Tangential stiffness models should almost certainly include a dependence on normal load.
 - What models are appropriate
 - How can we improve the models we have?
 - How do we capture time dependence?
- Measurement of stiffness in real contacts is not straightforward.
 - There is a need for reconciliation between different techniques.
 - We cannot model what we cannot measure.
- Modelling friction is far more challenging than contact stiffness
 - More multiphysics in this problem
 - Once again, time dependence is an issue
 - We need better models for wear



Imperial College
London

Part 2:

FRICIONAL SHAKEDOWN

18



Punch on Half Plane with Tension

Imperial College
London

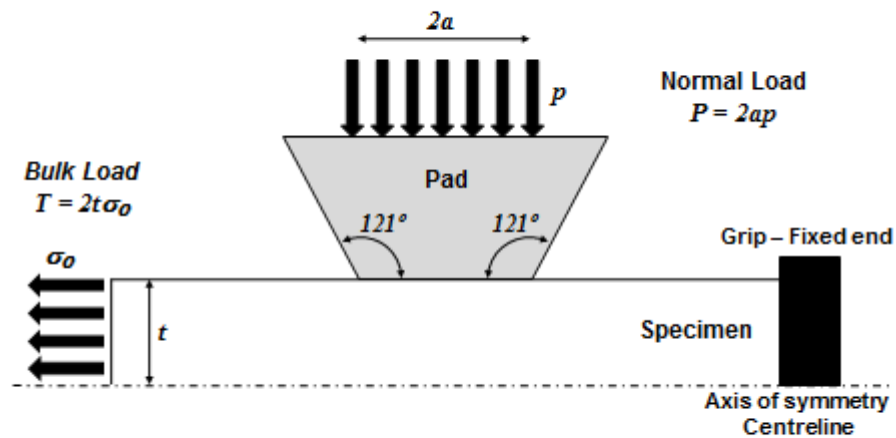

Simplified Model: Load vs. f Map

Imperial College
London

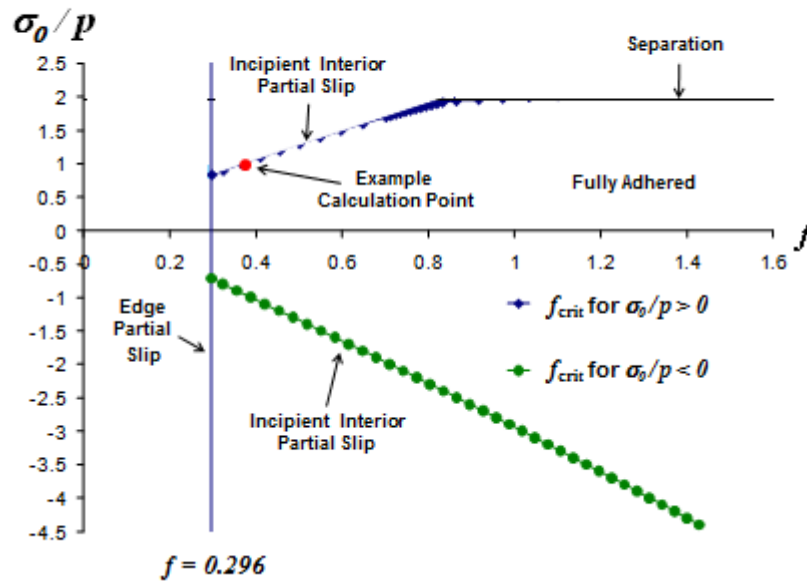



Simplified Model: Load vs. f Map

Probing shakedown

Imperial College London

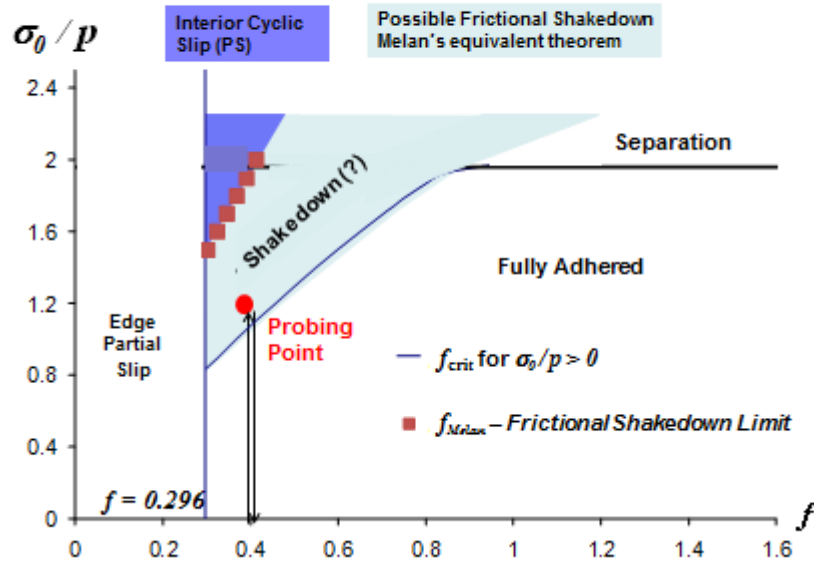

Simplified Model: Load trajectories

Imperial College London

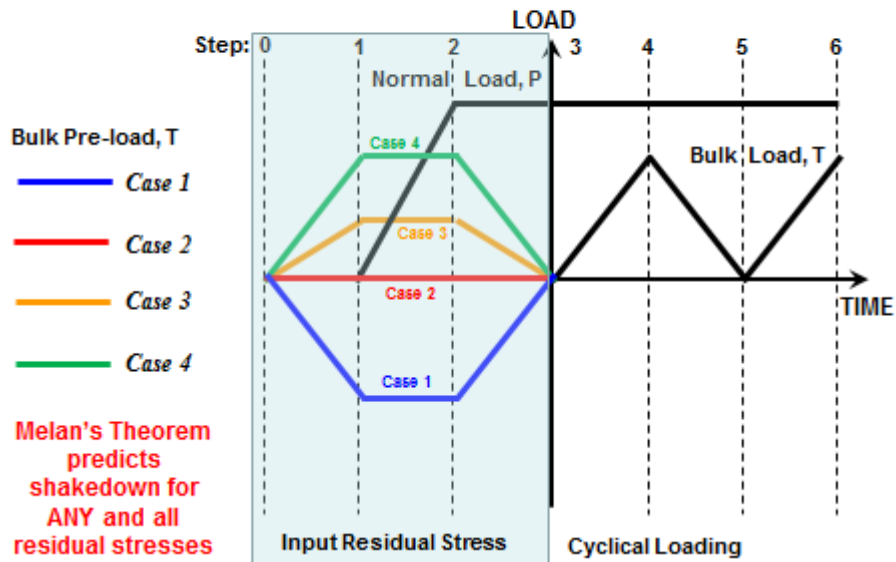

Imperial College London

Loading Sequence: History - 4 Cases

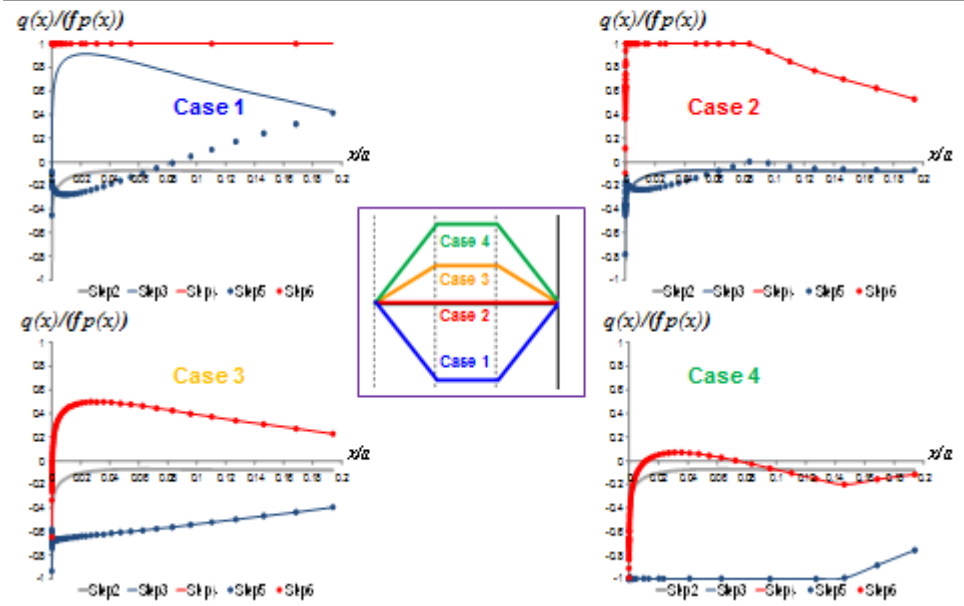

Imperial College London

Case 2 (no pre-stress) Does it shakedown ?

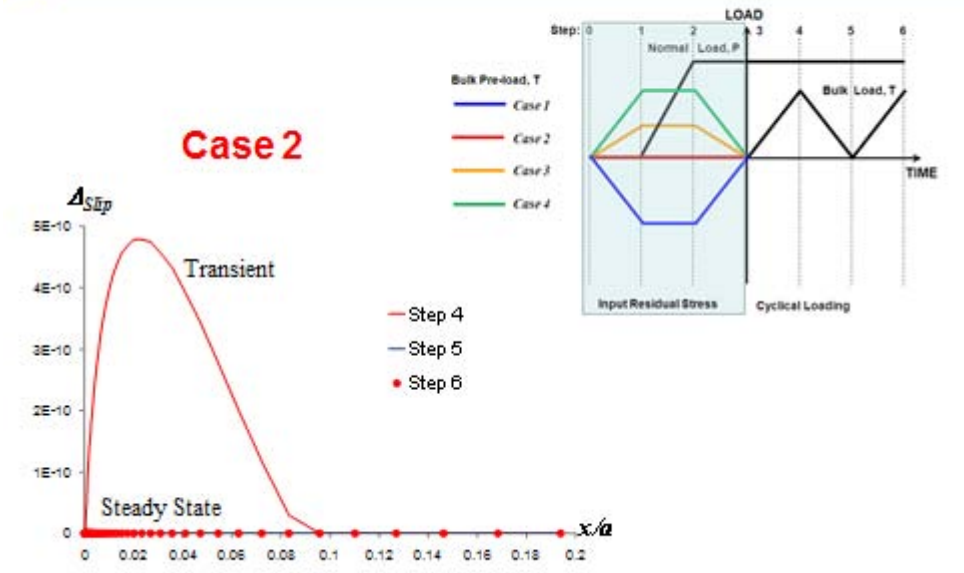

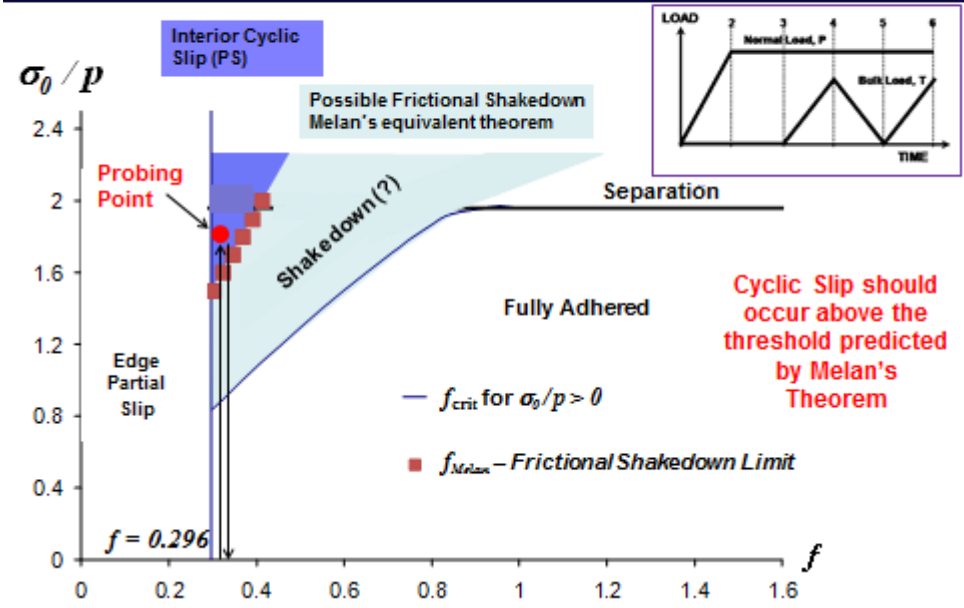

Simplified Model: Load vs. f Map
Imperial College London

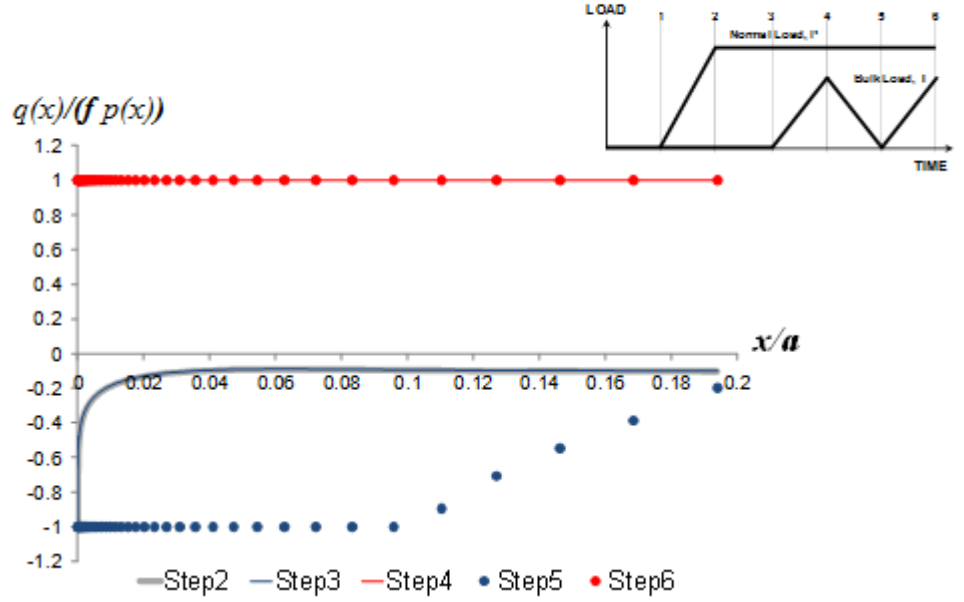

Loading Sequence: Interior (?) Cyclic Slip
Imperial College London

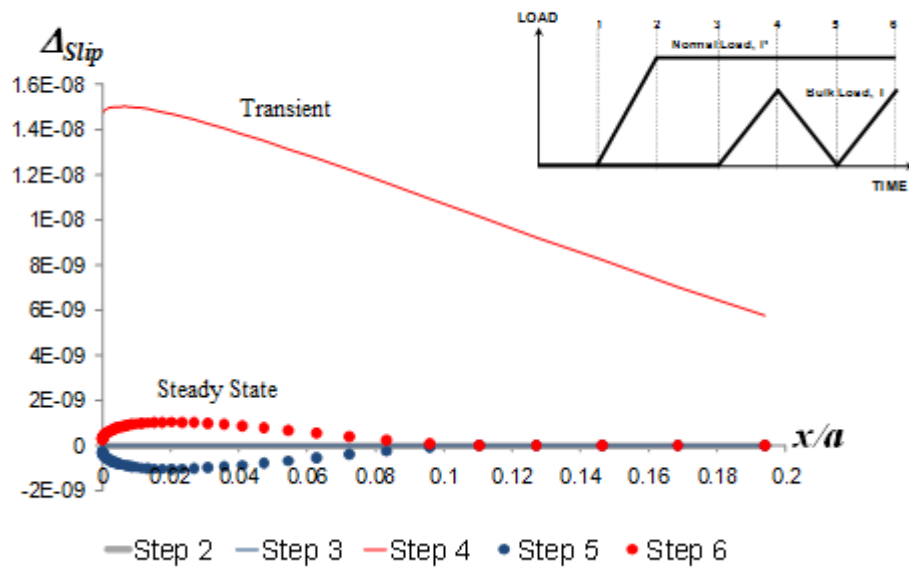







9. Physics-Based/Data Driven Modeling
 M. Eriten

Physics-based vs. Data-driven Modeling

Melih Eriten

August 16, 2012
 UIUC-LNDVL
 UIUC- μ TDL
 WISC-TNDL





Need for a Reduced-order Model

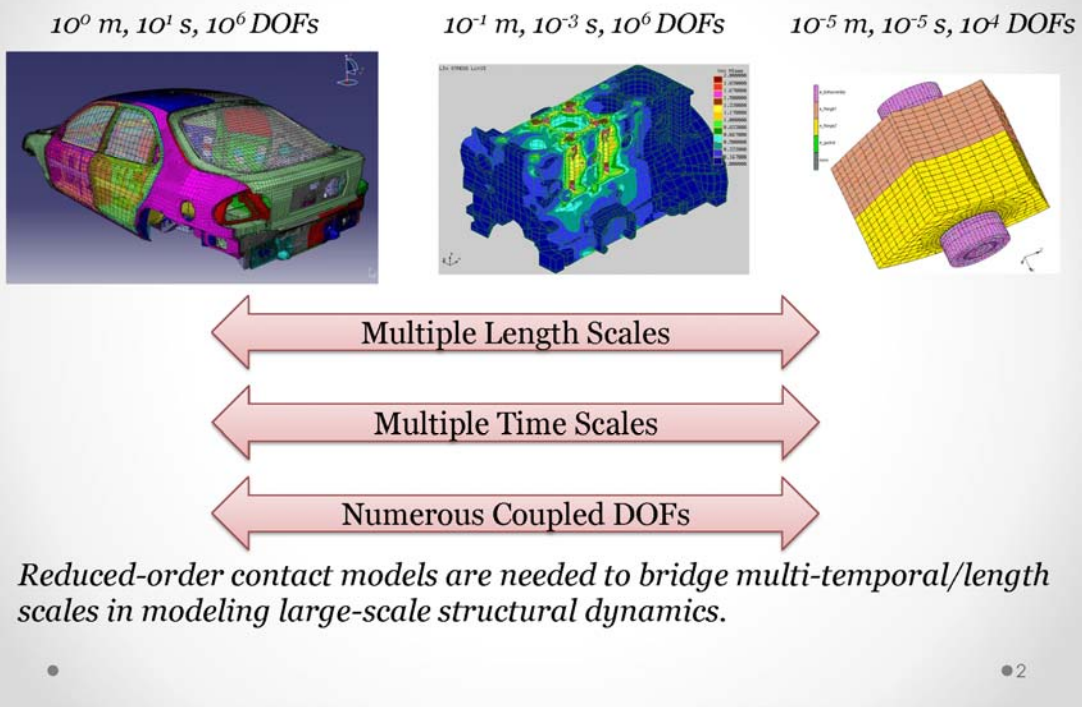

Multiscale Testing and Modeling: Two Approaches

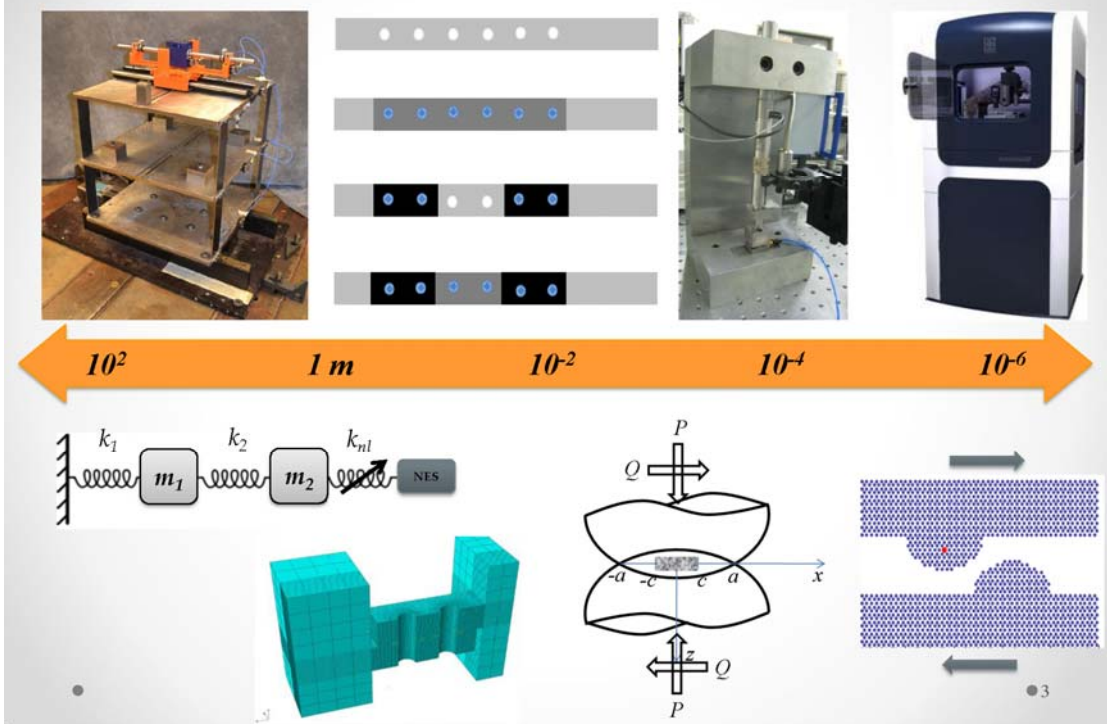

Bottom-Up Approach: Interface Mechanics

Internal combustion engine

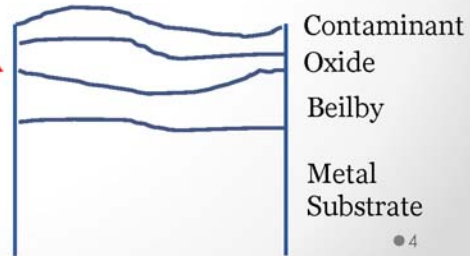
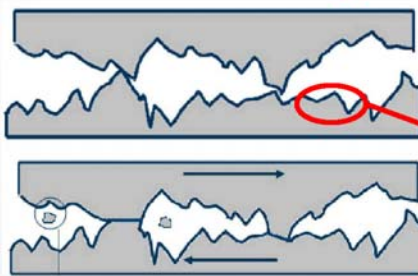
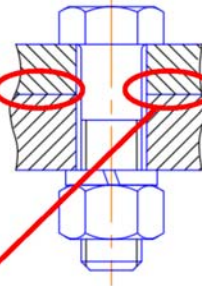

Multiscale Modeling: Outline

Eriten et al., *ASME J. Vib. Acoust.*, 2011.; Truster et al., *Int. J. Solids Struct.*, 2012.

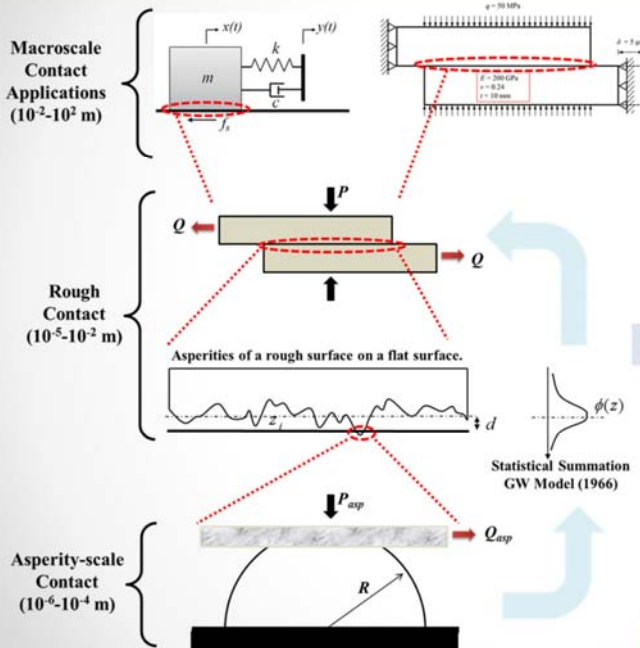

Eriten et al., *Int. J. Solids Struct.*, 2011.

Eriten et al., *Int. J. Solids Struct.*, 2010.

Bottom-Up Approach Outcomes

➤ Joint Fretting Apparatus

➤ Multiscale Friction Model

➤ Journal articles:

1. Lee, C.-H.; Eriten, M.; Polycarpou, A. A. *ASME J. Tribology* **2010**, *132*, 031602–11.
2. Eriten, M.; Polycarpou, A. A.; Bergman, L. A. *Int. J. Solids Struct.* **2010**, *47*, 2554–2567.
3. Eriten, M.; Polycarpou, A. A.; Bergman, L. A. *J. Appl. Mech.* **2011**, *78*, 021011.
4. Eriten, M.; Polycarpou, A. A.; Bergman, L. A. *Wear* **2011**, *271*, 2928–2939.
5. Eriten, M.; Polycarpou, A. A.; Bergman, L. A. *Exp. Mech.* **2011**, *51*, 1405–19.
6. Eriten, M.; Polycarpou, A. A.; Bergman, L. A. *Int. J. Solids Struct.* **2011**, *48*, 1436–1450.
7. Eriten, M.; Petlicki, D. T.; Polycarpou, A. A.; Bergman, L. A. *Mech. Mat.* **2012**, *48*, 26–42.
8. Eriten, M.; Polycarpou, A. A.; Bergman, L. A. *ASME J. Vib. Acoust.* **2012**, *134*, 051012.
9. Chandrasekar, S.; Eriten, M.; Polycarpou, A. A. *J. Appl. Mech.* **2012**, doi: 10.1115/1.4007212.
10. Eriten, M.; Lee, C.-H.; Polycarpou, A. A. *Tribology Int.* **2012**, *50*, 35–44.
11. Truster, T. J.; Eriten, M.; Polycarpou, A. A.; Bergman, L. A.; Masud, A. *Int. J. Solids Struct.* **2012**, (in press).
12. Eriten, M. *J. Mech. Phys. Solids*, (submitted).

•

• 6

Top-Down Approach: Need for the NSI

Amplitude dependent
damping/stiffness

Discontinuities, impacts,
clearance, backlash, etc.

Case study:

- Added damping due to friction
- Essential nonlinearities

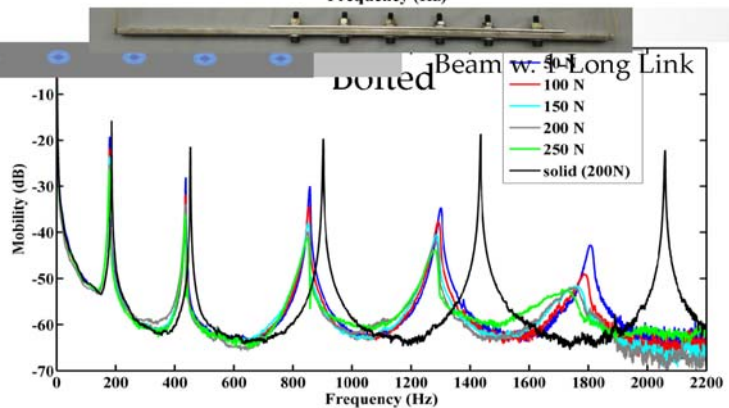
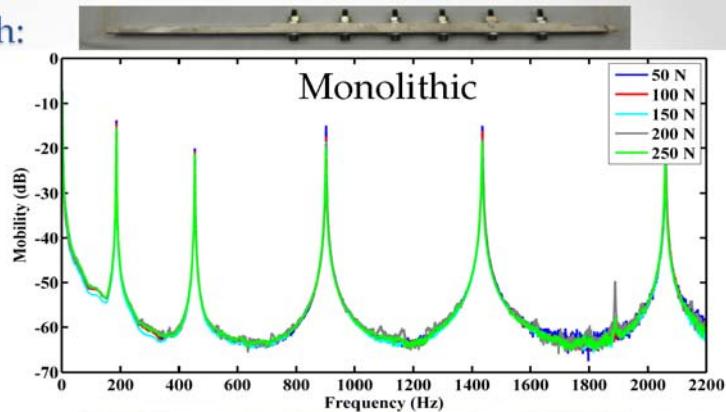

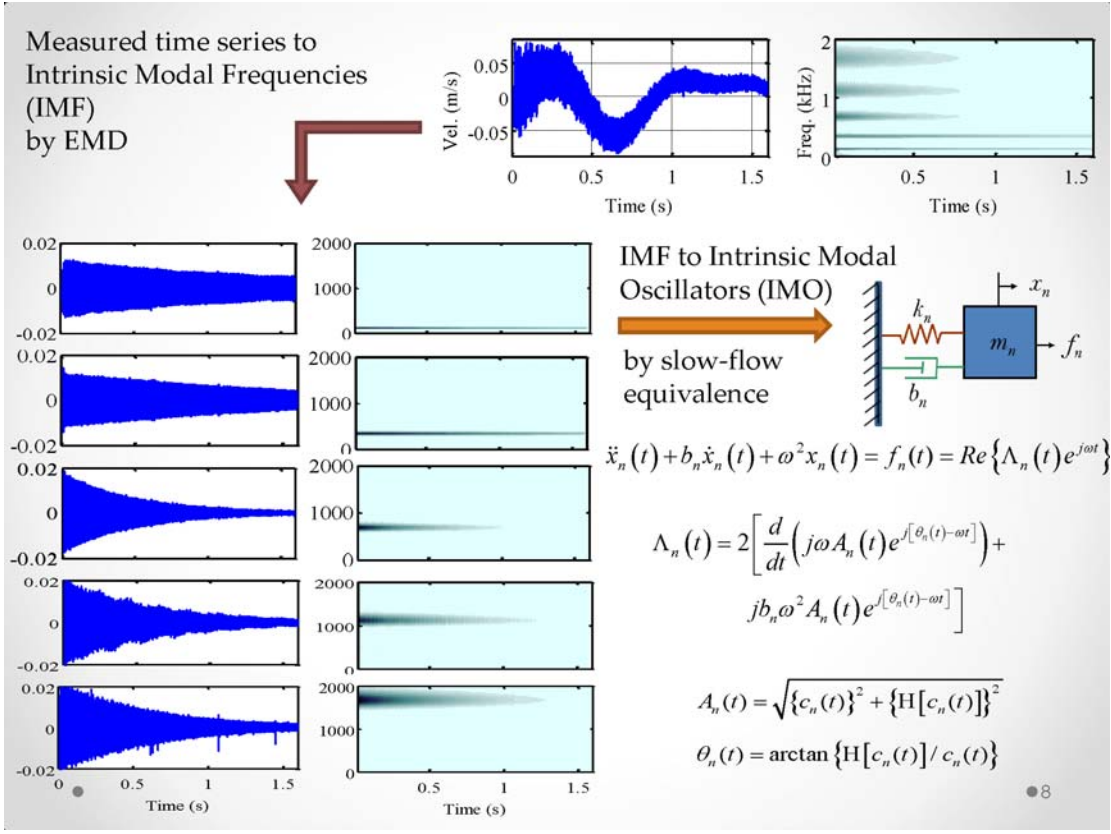

Energy-Dependence of Structural Damping

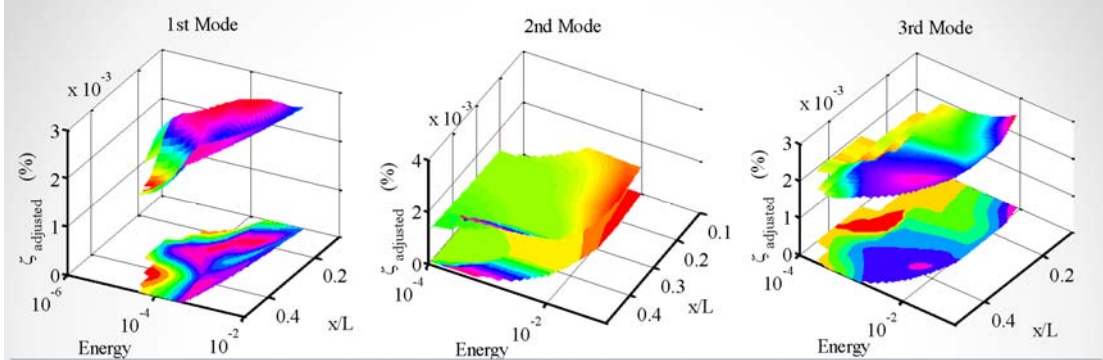

- Clear indication of nonlinearity in damping distribution
- Comprehensive identification in modal, spatial, and energy domain
- Damping increases with increasing hammer excitation in a nonlinear manner → joint-like

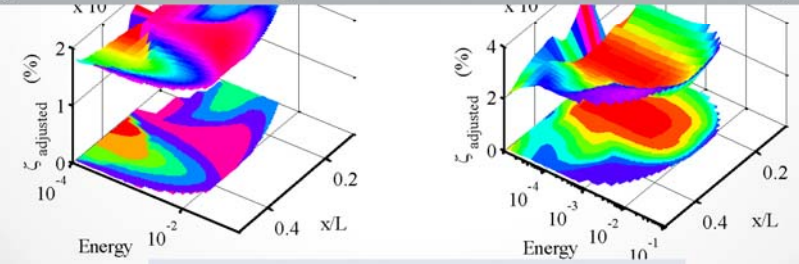

Eriten et al., Mech. Syst. Signal Pr. submitted.

Spatio-Temporal Decomposition (Mode Shapes)

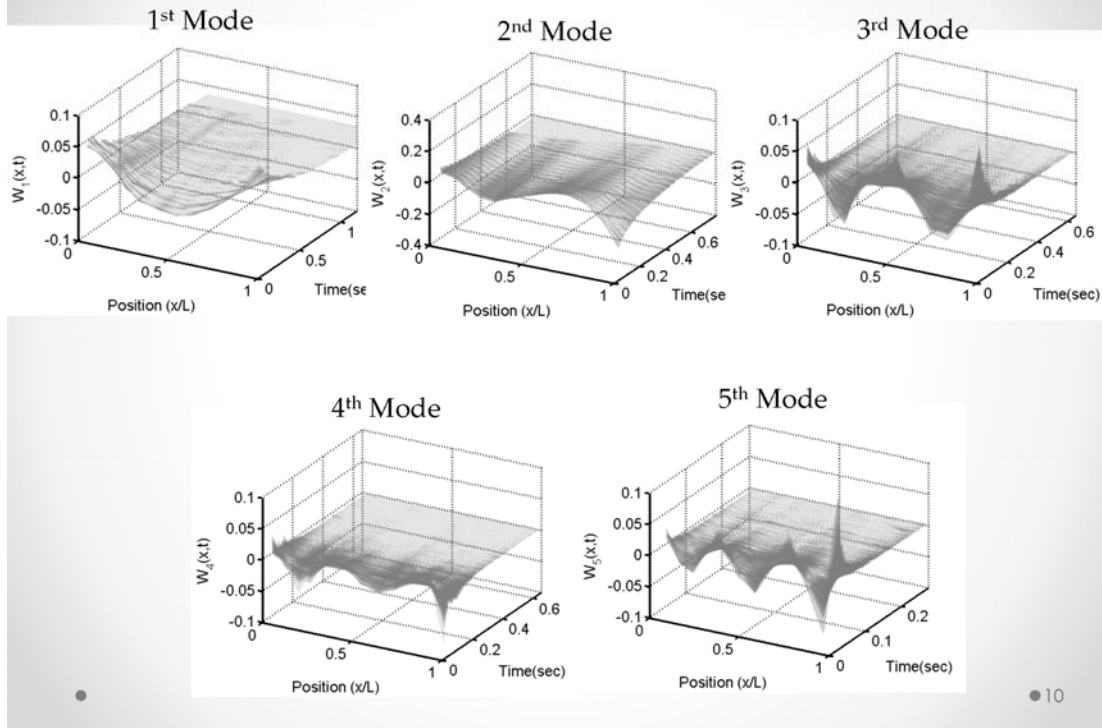

Top-Down Approach Outcomes

➤ Identification technique: NSI

➤ Journal articles:

1. Eriten, M.; Kurt, M.; Luo, G.; McFarland, D. M.; Vakakis, A. F.; Bergman, L. A. *Mech. Syst. Signal Pr.*, (submitted).
2. Kurt, M., Eriten, M., McFarland, D. M., Bergman, L. A., and Vakakis, A. F. *J. of Sound and Vibration* (submitted).

● 11

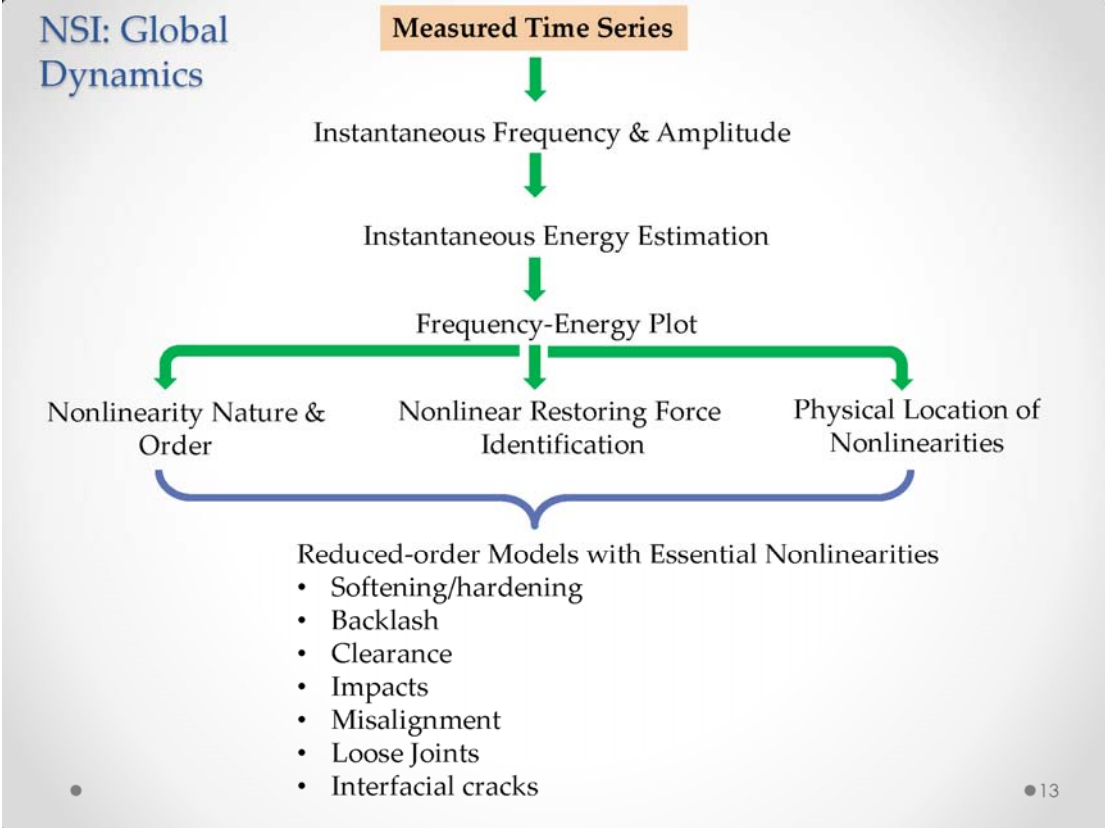
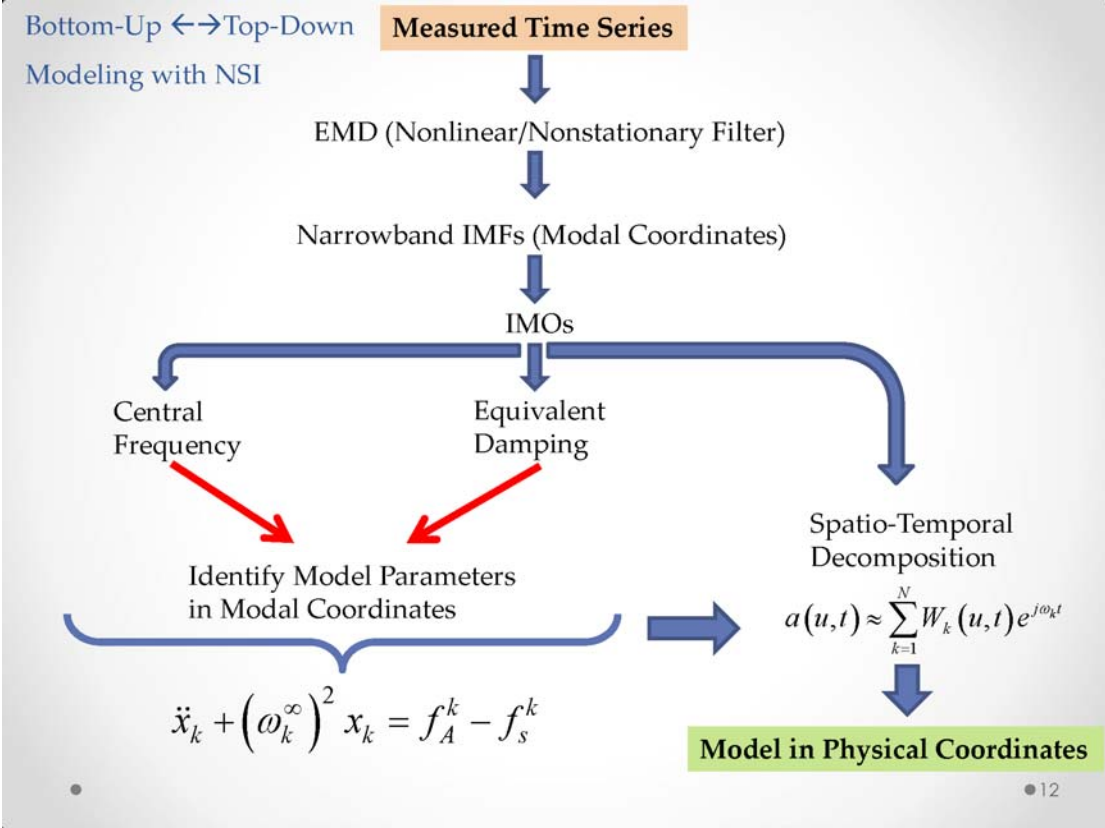

10. View from Germany

L. Gaul and B. Stingl



INSTITUT FÜR
MECHANIK



Universität Stuttgart

Joins Workshop Technical Talk

o.Prof. Dr.-Ing.habil. Lothar Gaul

Institut of Applied and Experimental Mechanics
University of Stuttgart

August 16, 2012

INSTITUT FÜR
MECHANIK

1

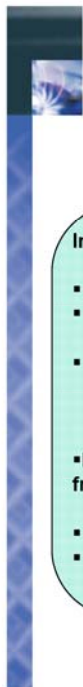

INSTITUT FÜR
MECHANIK



Universität Stuttgart

Important Topics in our Area

➤ Nonlinear or Linearized Joint Modeling

Industrial Problems	Research Problems
<ul style="list-style-type: none">Local Joint ModelsNonlinear FE Joint Models (Zero Thickness Elements)Linearized FE Joint Models (Thin Layer Elements) <p>Identification of Joint Model Parameters from isolated joints</p> <ul style="list-style-type: none">Resonator measurements, Pressfit jointsOptoelectronic measurements	<ul style="list-style-type: none">Surface roughness description Herz-Mindlin Theory for single asperities<ul style="list-style-type: none">Greenwood Williamsen TrippStochastic roughness modelsFractal surface descriptionMulti particle dynamicsNonlinear normal and tangential contact equationsHarmonic balance descriptionModeling of Epistemic and Aleatoric uncertainties

2

Important Topics in our Area

Industrial Contact Problems

- SRTM 10 bay space frame with passive and semi-active joints
- Bolted housing of airbag control unit
- Damping description in design phase of
 - motors with attached gearbox (cars, trucks, yachts, ships)
 - bolted joints of cylinder head, oilpan, gearbox
 - influence of different seal systems
- Uncertainty description of assembled structures with joints
- Joints in tooling industry, Pressfit joints in turbogenerators
- Disc brake contact problems
- Bolted joint damping layers (exhaust systems)

Control problems for structures with semi-active joints

- Control concepts
 - Ljapunov controller, maximizing dissipation
 - Clipped LQG SISO-, MIMO-controller

3

Which Problems to Take in

SRTM 10 bay space frame with passive and semi-active joints
Optimal actuator and sensor placement concepts

- Scientific interest in collaboration with colleagues, such as the brake dynamics group organized by Harald Abendroth
- Funding offers by
 - FVV (Forschungsvereinigung Verbrennungsmotoren)
 - DFG (German Research Society)
 - Research groups
 - Transfer for Industrial problems
 - State funding (BW)

4

End User of Results / Funding

Who will be the end user of the results?

- Industry
 - Automotive suppliers
 - Car industry
 - Machine tools industry, Turbomachinery design
 - Optical industry
 - Biomedical industry (stent design, lithotripter design, peristaltic transport)
- Inventors
- Small business

How we get funding?

- Contact with Industry by local and international conferences
- DFG, FVV, VDMA
- Individual contacts
- Courses organized by IAM at HDT, VDI etc.

5

Friction-induced vibrations in brake systems

- Development of “silent” friction brakes is a major challenge in automotive industry
- Brake squeal is largely understood (qualitatively + quantitatively)
- BUT: prediction capabilities of simulation tools are poor
- State of the art tool: complex eigenvalue analysis MT1



Overprediction of instabilities

- Damping and nonlinearities mainly determine stability of the brake system

→ Joints have to be taken into consideration

MT2



- MT1 Komplexe Eigenwertanalyse eines linearen FE-Modells (MDGKN-System)
Merten Tiedemann, 8/1/2012
- MT2 Wichtige Fügestellen:
- Scheibe-Belag
- Belag-Sattel
- Sattel-Halter
Merten Tiedemann, 8/1/2012

Challenges in the field of brake squeal simulation

- Characterization and description of nonlinear joint dynamics
- Implementation of joint models in commercial FE software
- Model order reduction
- Nonlinear stability analysis / limit cycle calculation

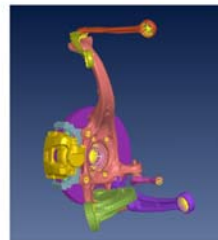

Gdaniec, P., Weiß, C., Hoffmann, N. (2010) On chaotic friction induced vibration due to dynamic friction. Mech. Res. Comm. 37, 92-95.

Hoffmann, N. (2007) Linear stability of steady sliding in point contacts with velocity dependent and LuGre type friction. Journal of Sound and Vibration 301, 1023-1034.

Friction as a Dynamical System?

Engineering

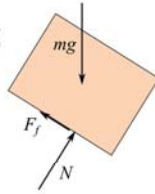

- material constant
- $F_f = \mu N$

Physics

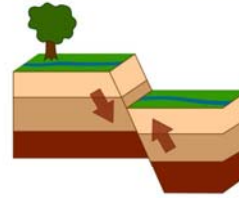

- dynamical system
- $\dot{F} = f(x, \dot{x}, F)$

Transfer state of the art knowledge to engineering?

- Is Coulomb friction sufficient?
- Can we apply extended friction models?

Where to apply?

Failure of joints

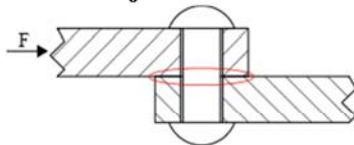

- extended interface with stress field
- failure \triangleq transition to sliding
- derivation of design rules
- monitoring systems, e.g. overload detection

Friction induced vibrations



- multiscale systems: structure and interface dynamics
- scales may interact \rightarrow separation of scales fails

Extended Friction Models

Roughness based



- repeated shearing, failure and reattachment of asperities

Bristle Model

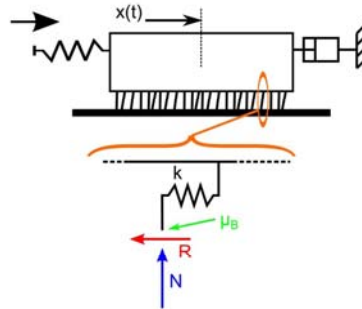

- rough interface: elastic bristles

Stingl, B., Hoffmann, N. (2011) A mesoscopic friction model based on surface roughness and its statistical description. Proceedings of the ASME Annual Meeting, Denver, 2011

Experimental Model Setup

- periodic interface
- shaft-hub-connection, clutch, screw-underhead contact, ...
- strain field measurement
- disturbed stress field by tilting

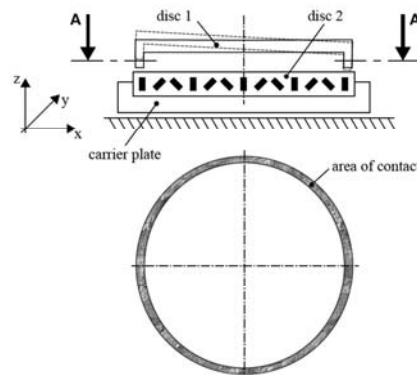

11. Flight Systems/Satellites/Weapons

D. Brown and D. J. Segalman



Nonlinearity of Joints in Structural Dynamics of Weapons Systems

Daniel Brown
AWE

Dan Segalman
Sandia National Laboratories†

† Sandia National Laboratories is a multi-program laboratory managed and operated by Sandia Corporation, a wholly owned subsidiary of Lockheed Martin Corporation, for the U.S. Department of Energy's National Nuclear Security Administration under contract DE-AC04-94AL85000.



WHY THIS IS IMPORTANT

- Joints are a (the) major source of variability and nonlinearity in our structures.
- Linear models are incorrect. Calibration in one experiment yields predictions that do not match other experiments.
- Propagation of parameter uncertainty with the wrong model form is nonsense.
- Tuning linear models to small-amplitude tests yields over-conservative models. Affordable designs are scrapped.
- Even though linear models are usually conservative - this is not always the case!





What we can do?

	Single Homogeneous Structure	Simple Assembly Level	Complicated Assembly Level
Natural Frequencies	✓	✓	✓
Mode Shapes	✓	✓	✓
Identify problem Frequencies	✓	✓	Depending on complexity
Amplitude	✓	✗	✗
Cumulative effects	Depending on problem	✗	✗



Even Simplest Systems are a Challenge

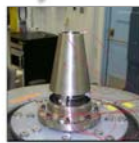

- Macro-slip and effective vibration isolation during blast
- High damping during sustained excitation

Acceleration predictions at forward mount joints:
Ti-SS mock 3-leg with shaker dynamics

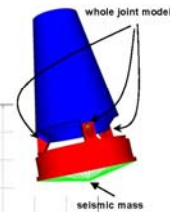
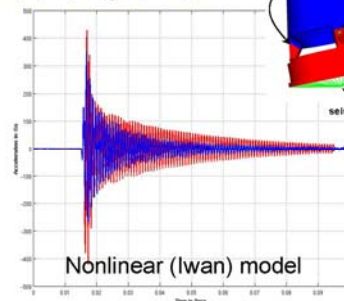
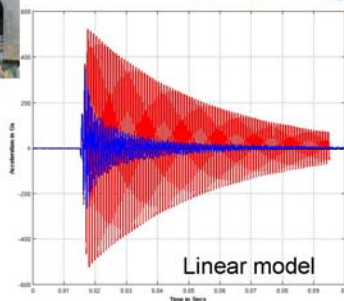

We can model individual joints (crudely) and insert them into a system model

— Experiment
— Model





What Next for Such Interfaces?

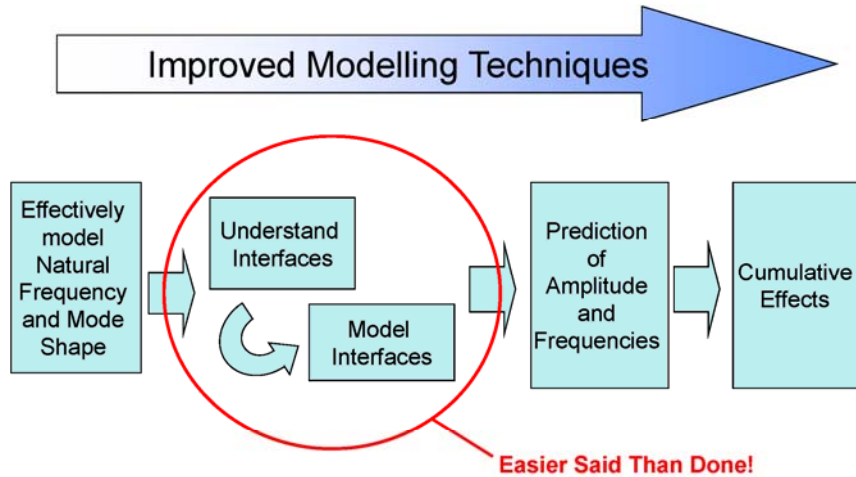

The Problem is Larger than Just an Occasional Lap Joint





Even Whole Subsystems May Behave in Joint-Like Manner

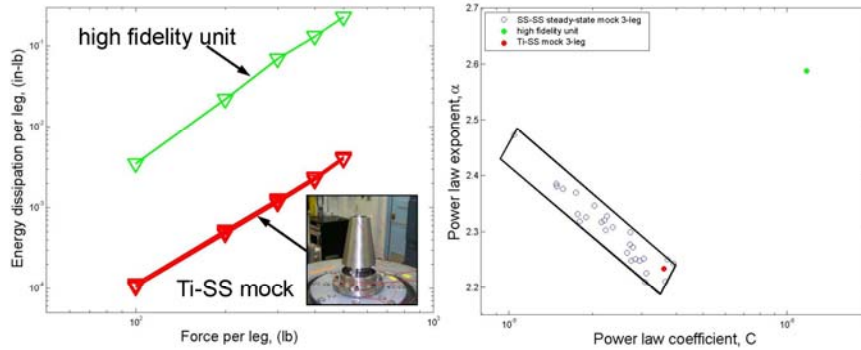

- The dissipation of the high-fidelity unit is very joint-like in nature.
- That dissipation is much more than can be explained by the forward mount joints alone.



Weapons systems contain a plethora of interfaces; How can we account for them in aggregate?

$$M\ddot{u} + C\dot{u} + Ku = F_X(t) + F_J(t, \{x_k^j\})$$

where F_J is force vector for joints and $\{x_k^j\}$ are state variables for joint j

$$\text{Postulate } F_J = M\Phi \left\{ \mathcal{G}_j(\alpha_j(\tau), \tau = -\infty, t) \right\}$$

where α_j are modal coordinates

$$\text{For modal BPII, } \mathcal{G} = \int_0^{\infty} \text{diag}(\{\rho_k(\phi)\}) \beta(t, \phi) d\phi$$

where

$$\dot{\beta}_k(t, \phi) = \begin{cases} \dot{\alpha} & \text{where } \dot{\alpha}(\alpha_k - \beta_k) > 0 \text{ and } |\alpha_k - \beta_k| = \phi \\ 0 & \text{otherwise} \end{cases}$$





How could we possibly determine the parameters for our nonlinear modal operators?

- Decompose the response in modal components
Look to empirical mode decomposition.
- Fit modal parameters in same way that joint parameters were fit.



Other Sorts of Nonlinear Joint: Consider Tape Joints

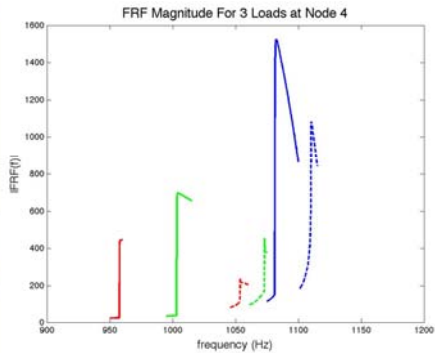
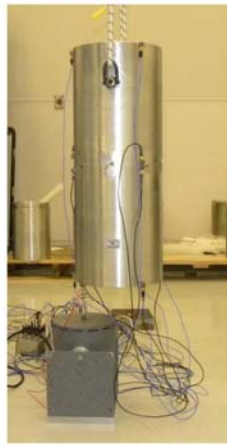
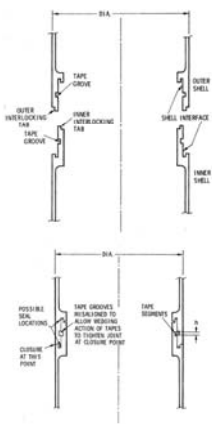

- Multiple FRF show system is very nonlinear
- Shows classic features of softening system

Response is more like that of a Duffing oscillator than that of a linear system





Assessing Where We Stand

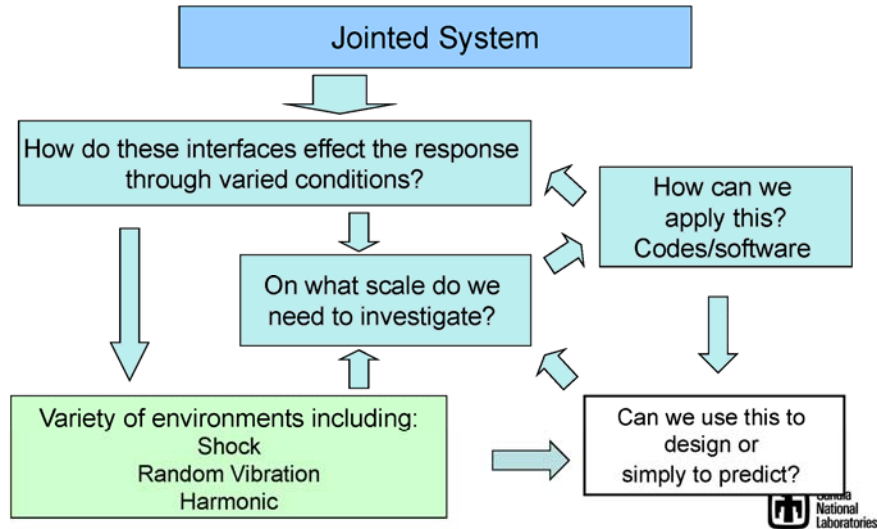

How to Move Forward?

- We do not have the resources to commit to significant and sustained in house research...

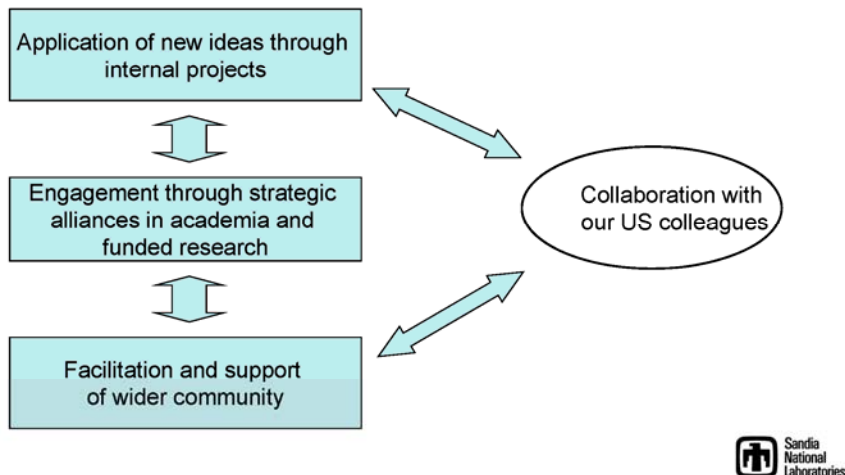

12. Vibrations/Turbine Engines

M. Gola and C. Schwingshackl



Politecnico di Torino
DIMEAS Dip. Ing.
Meccanica e Aerospaziale

Imperial College
London
Vibration University Technology Centre

Joins Workshop Vibration and Turbomachinery

Muzio M. Gola

Professor of Machine Design
Team leader LAQ AERMEC
DIMEAS -POLITO
muzio.gola@polito.it

C. Schwingshackl

Lecturer in the Dynamics Group
Vibration University Technology Centre
Mechanical Engineering
Imperial College London
c.schwingshackl@imperial.ac.uk

Theoretical research

Imperial College
London
Vibration University Technology Centre

- Development of nonlinear tools
 - Friction contact elements
 - Bifurcation and instability
 - Graphical user interfaces
- Application to aircraft engine
 - Methodology
 - Response behaviour
- Validation
 - Against experimental data

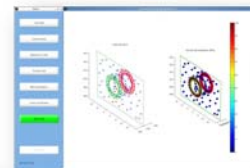
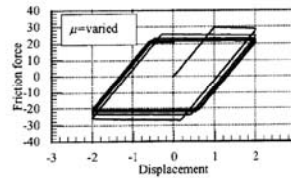

Schwingshackl

2

Experimental research

- Basic research
 - Friction contact behaviour
- Nonlinear structural damping
 - Engine components
 - Blade root
 - Under platform damper
 - Flange
 - Rotating and stationary systems
- Measurement techniques for nonlinear behaviour
 - Large amplitude excitation
 - Data processing



Schwingshackl

3

An example of our current work: Nonlinear flange joint analysis

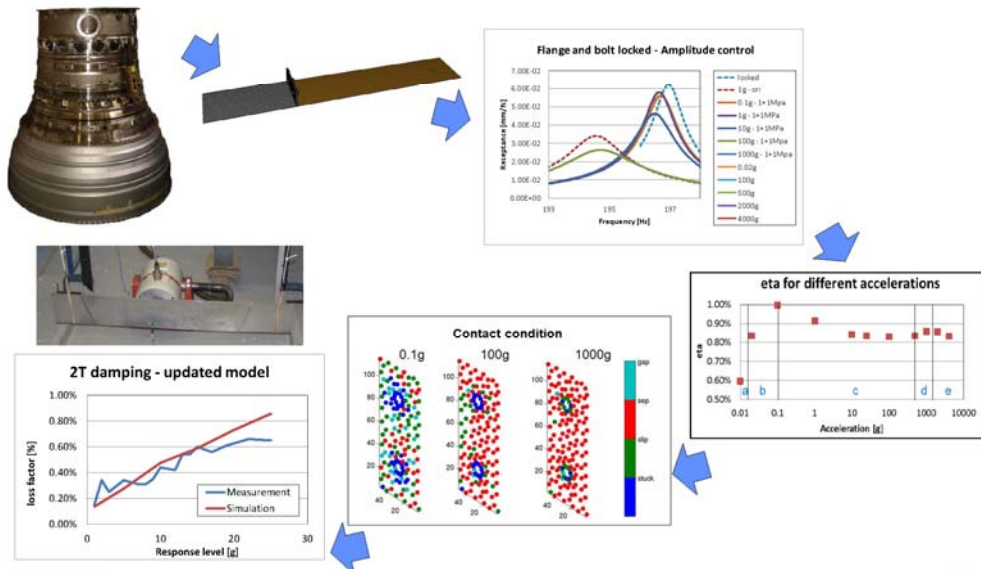

Schwingshackl

4

Main problem areas

- **Overall dynamic response of structure**
 - Effect of joint on stiffness and damping
- **Need for robust prediction methods**
 - Macro level
 - Variability of joints
 - Contact conditions unknown
- **Designing joints that are insensitive**
 - Manufacturing tolerances
 - Wear
- **Industrial environment**
 - Damper design has matured and is routinely used
 - Focus is shifting to
 - new joint types
 - large models



Schwingshackl

5

What needs to be done

- **Robust tools for joint analysis**
 - Fast and reliable
 - Large scale modelling
 - Too much detail may get in the way
 - Change over time
- **Criteria for effective joint design**
 - Don't deal with it, use it
- **Nonlinear friction joint validation**
 - Which parameters?
 - Level of validation
 - Global or local response
- **Novel test methods**
 - Operational level testing
 - Data processing



Schwingshackl

6



Politecnico di Torino
DIMEAS Dip. Ing.
Meccanica e Aerospaziale

Overview of requests from companies / european projects (funding)

Contact mechanics and tribology
Sliding wear tests in vibration

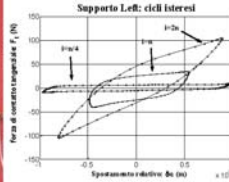
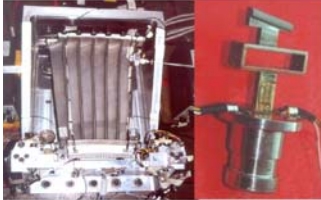

Damper mechanics and wear

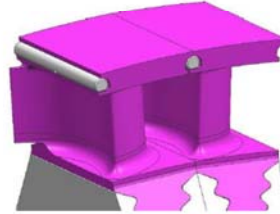

Contact modelling on rotating components

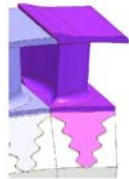

Schwingshackel

Turbine and gear dynamics (flutter, mistuning)



Damping and wear assessment on blades

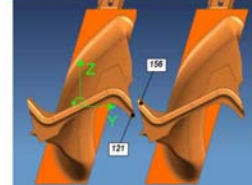

Politecnico di Torino
DIMEAS Dip. Ing.
Meccanica e Aerospaziale

Overview of capabilities

Contact mechanics and tribology

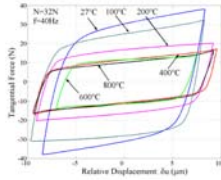

Damper mechanics on dedicated test rigs and on rotors

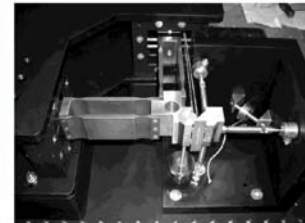
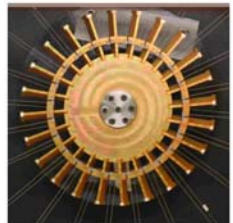

Contact modelling on rotating components

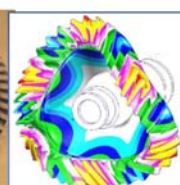
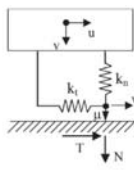

Turbine and gear dynamics & damping



Poli.Contact: Non-linear Simulation Code

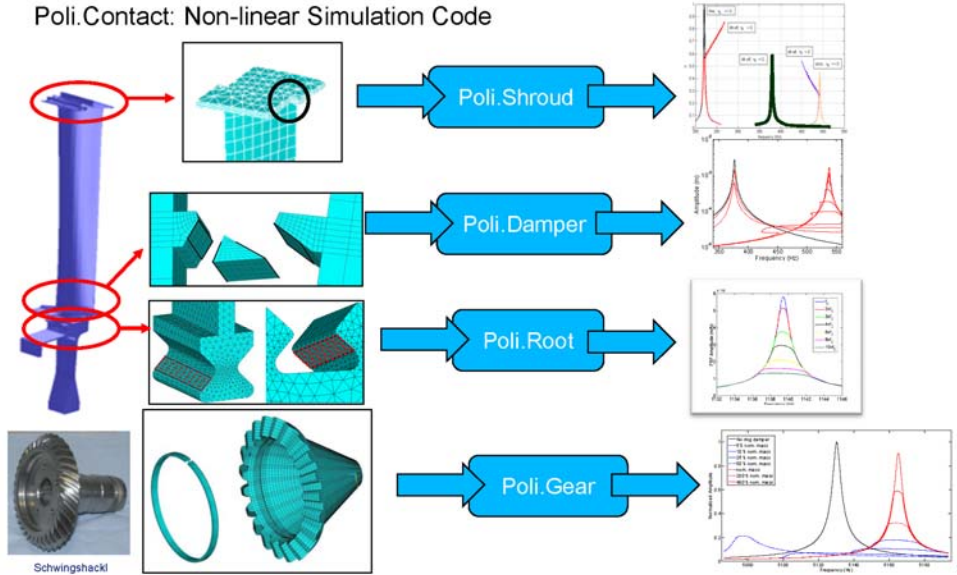

Validation of Contact Models: High Temperature Test Rig No. 1

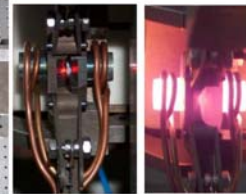
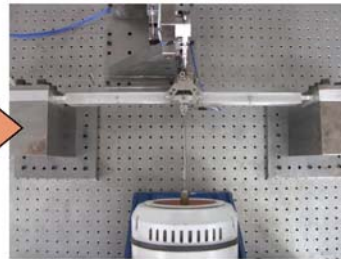
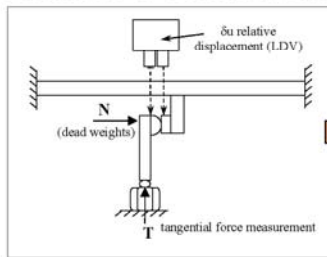

Working range:

- Temperature : 20 – 1000 ° C
- Displacement: 0,1 μm - 100 μm
- Normal loading: 1kg a 10kg
- Excitation frequency: 1 - 100Hz

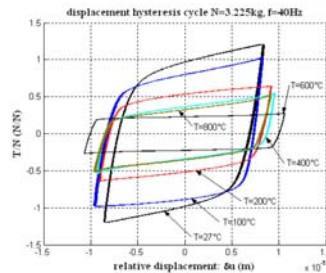

Schwingshackl

10



Politecnico di Torino
DIMEAS Dip. Ing.
Meccanica e Aerospaziale

Friction Damping @ LAQ AERMEC

Validation of Contact Models: High Temperature Test Rig No. 2

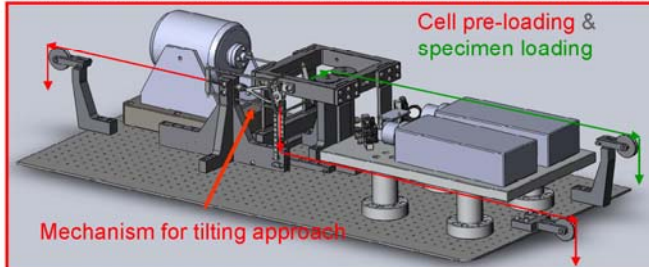

- Test Frequency: 2 ÷ 200 Hz;
- Relative motion range 2 ÷ 100 μm
- Temperature up to 1000° C
- Overall force measurement error : ~ 0,7%
- Overall displacement measurement error: < 1%
- Feedback control of the test conditions (temp. & displ.)

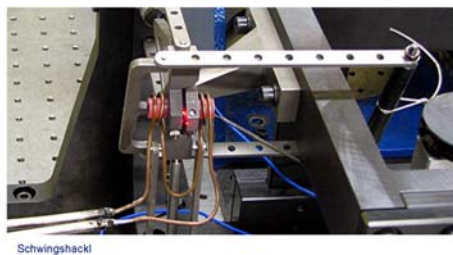

Schwingshackl

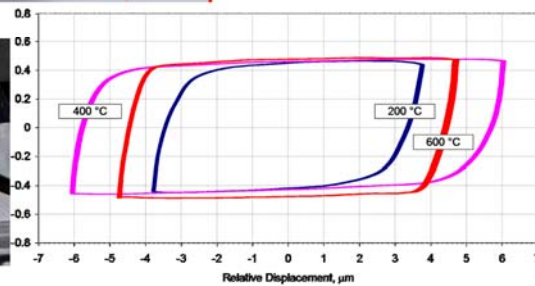

Politecnico di Torino
DIMEAS Dip. Ing.
Meccanica e Aerospaziale

Friction Damping @ LAQ AERMEC

Validation of Contact Models: Wear Measurements

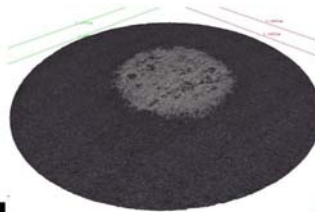
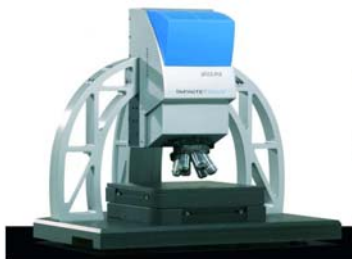

Inconel 718 - T800 coated

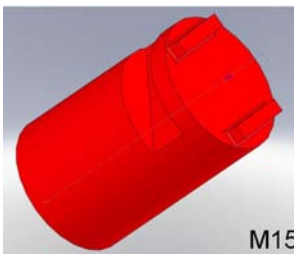
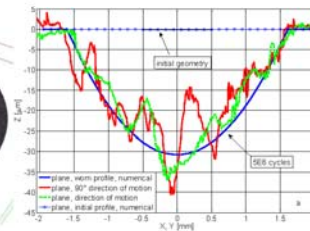

M152 steel

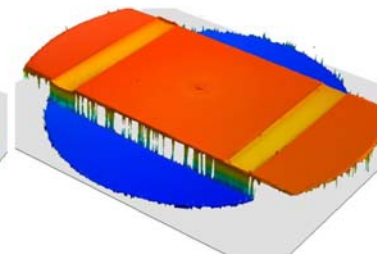
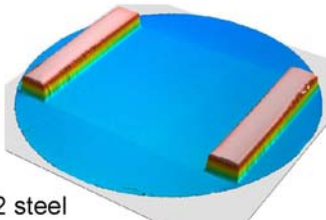



Validation of Contact models (blade/root joints)

Numerical Contact Model

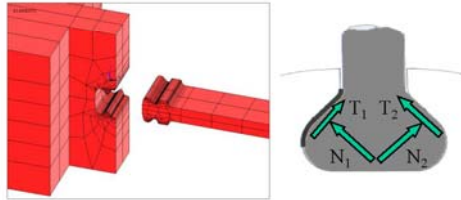

The Test Rig

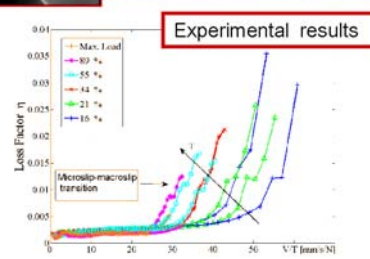
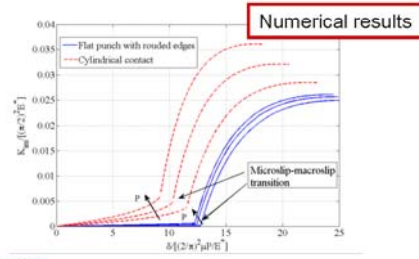

Schwingshackl

13



Development & Validation of Damper Models

The underplatform damper is a free body pressed against the blade platforms by centrifugal force.



Damper models are necessary to simulate the complex damper kinematics.

1
Through damper
response

Two-Blade Test Rig

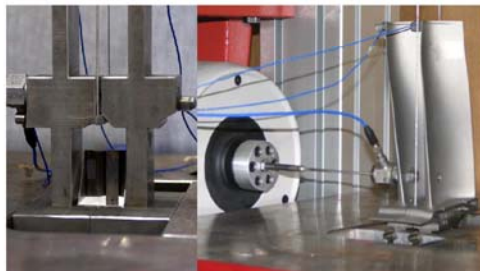

Schwingshackl

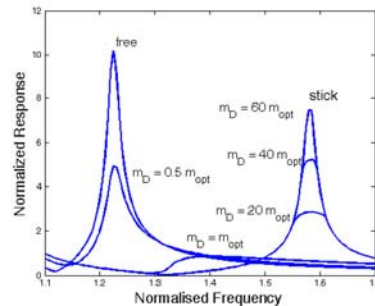

1



Politecnico di Torino
DIMEAS Dip. Ing.
Meccanica e Aerospaziale

Friction Damping @ LAQ AERMEC

Development & Validation of Damper Models

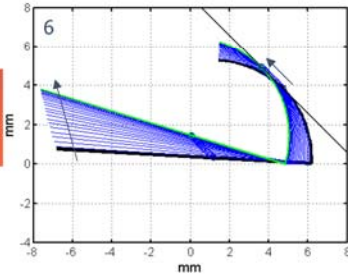
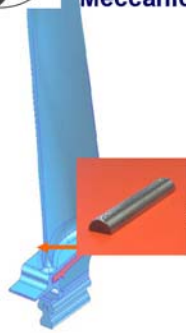

2
Through hysteresis cycle
damper force and
kinematics measurements

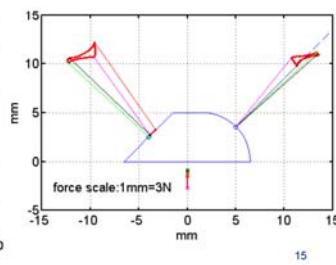
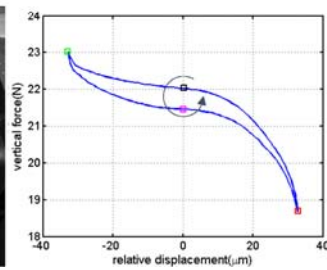
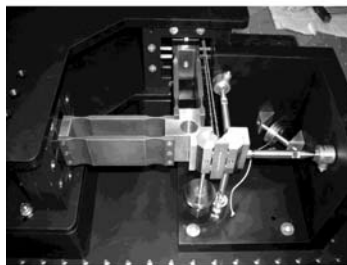

Politecnico di Torino
DIMEAS Dip. Ing.
Meccanica e Aerospaziale

Friction Damping @ LAQ AERMEC

Full scale tests & mistuning

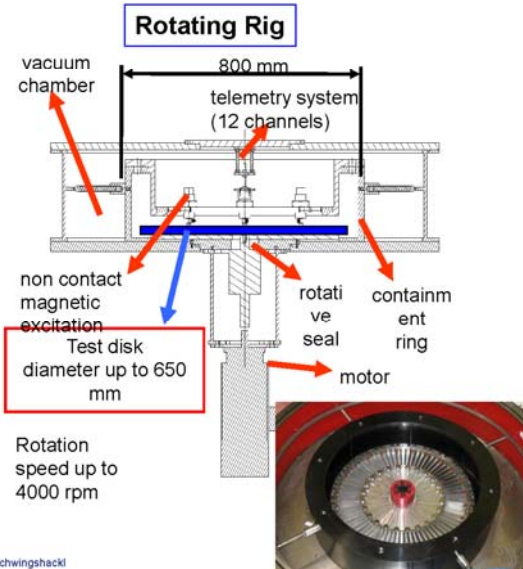

Static Rig

underplatform dampers & shrouds

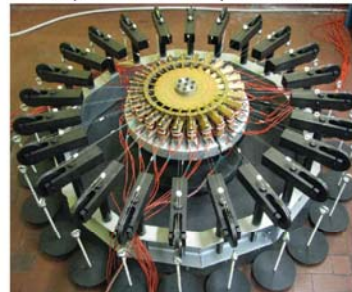

non-contact
rotating
excitation by
electromagnets

16



Politecnico di Torino
DIMEAS Dip. Ing.
Meccanica e Aerospaziale

Imperial College
London
Vibration University Technology Centre

Some other considerations

- **How to determine which problems to tackle**
 - Experience and discussions within the institution
 - Good understanding of the needs from industry
 - Conferences and this workshop
- **Who will use your research?**
 - Strong industrial focus
 - Rolls-Royce, AVIOGroup, GE-NP, ANSALDO?
- **Where is the funding coming from?**
 - Industrial partner directly
 - Government/Industry partnership
 - European Projects



Schwingshackl

17

13. Uncertainty Approaches to Joints and Interfaces

M. Mignolet

UNCERTAINTY MODELING ISSUES: SOME PRELIMINARIES

Marc P. Mignolet

SEMTE, Faculties of Mechanical and Aerospace Engineering
Arizona State University



*Ira A. Fulton Schools of Engineering
SEMTE, Faculties of Mechanical and Aerospace Engineering
Structural Dynamics Group*



EPISTEMIC VS. ALEATORY

Epistemic (or model or reducible) uncertainty

Observed when the response of the system cannot be matched by the model predictions irrespectively of the model parameters, e.g. curved beam modeled by a straight one, nonlinear system represented by a linear one, ...

Aleatory (or parameter or irreducible) uncertainty

Observed when the response of the system can be matched by the model predictions for an appropriate choice of the parameters which is different for different structures, e.g. random Young' modulus

Improving the model tends to reduce epistemic uncertainty but increase aleatory uncertainty



*Ira A. Fulton Schools of Engineering
SEMTE, Faculties of Mechanical and Aerospace Engineering
Structural Dynamics Group*



EPISTEMIC VS. ALEATORY

The “type” of model affects the balance of epistemic/aleatory uncertainty

Detailed (finite element) model:

Aleatory uncertainty can be introduced only in the “mechanical/material” properties

Global (modal) model:

Aleatory uncertainty extends to broad set of parameters (e.g. elements of stiffness matrix) that can include some uncertainty seen as epistemic in the detailed model, e.g. curvature of beam including in stiffness matrix



*Ira A. Fulton Schools of Engineering
SEMTE, Faculties of Mechanical and Aerospace Engineering
Structural Dynamics Group*



UNCERTAINTY MODELING: NOT AN AFTERTHOUGHT!

Scenario 1: All structures of interest are tested

Proceed with deterministic identification and adjust model parameters from structure to structure. *No uncertainty modeling is needed.*

Scenario 2: a few nominally identical structures are tested and many more are of interest (usual case). *Uncertainty modeling is needed. How?*

Example: FRF of a N dof system is measured and damping ratios ζ_i are observed to be uncertain.

How do we proceed? Two options...



Ira A. Fulton Schools of Engineering
SEMTE, Faculties of Mechanical and Aerospace Engineering
Structural Dynamics Group



UNCERTAINTY MODELING: NOT AN AFTERTHOUGHT!

(1) proceed with deterministic identification and backtrack an uncertain model of the parameters.

FRF^(j) → $\zeta^{(j)}$ using deterministic ID, then represent $\zeta^{(j)}$ using an uncertainty model and identify the parameters $\underline{\theta}$ of this model.

(2) create and identify an uncertain model of the structure (or model of the uncertain structure) that combines structural and uncertainty aspects. That is, express

$$\text{FRF}^{(j)} = \text{FRF}^{(j)} [\zeta^{(j)} (\underline{\theta})]$$

and identify directly (e.g. maximum likelihood) the parameters $\underline{\theta}$.



Ira A. Fulton Schools of Engineering
SEMTE, Faculties of Mechanical and Aerospace Engineering
Structural Dynamics Group



UNCERTAIN MODEL VALIDATION

Uncertain model = structural + uncertainty model

Option 1:

Validate the structural model in detail (epistemic uncertainty?) and the uncertainty modeling separately.

Option 2:

Validate the overall model on the responses of interest and assess whether the model *statistically* predicts these responses, e.g. they lie within the 5-95 percentile confidence (uncertainty) band with 10% probability.

Should we still focus on validating/improving structural model?



Ira A. Fulton Schools of Engineering
SEMTE, Faculties of Mechanical and Aerospace Engineering
Structural Dynamics Group



UNCERTAIN MODEL VALIDATION

Uncertain model = structural + uncertainty model

Option 1:

Validate the structural model in detail (epistemic uncertainty?) and the uncertainty modeling separately.

Option 2:

Validate the overall model on the responses of interest and assess whether the model *statistically* predicts these responses, e.g. they lie within the 5-95 percentile confidence (uncertainty) band with 10% probability.

Should we still focus on validating/improving structural model? **YES!!!**



Ira A. Fulton Schools of Engineering
SEMTE, Faculties of Mechanical and Aerospace Engineering
Structural Dynamics Group



MODELING COMPLEXITY

Does the model used when uncertainty is present need to exhibit full complexity?

Not necessarily - maybe or maybe not...

Fine details in the response may not need to be captured as they will become “invisible” when uncertainty is introduced.

Classical Example:

Probability density function (stationary) of the response of a Duffing oscillator to white noise excitation does not require the classic single-frequency analyses but its spectrum estimation may involve it.



Ira A. Fulton Schools of Engineering
SEMTE, Faculties of Mechanical and Aerospace Engineering
Structural Dynamics Group



UNCERTAINTY MODELING

Tools for Uncertainty Modeling:

Probability Theory, Fuzzy Logic, Possibility Theory,...

Random variables, stochastic processes and fields:

Uncertain parameters modeled through their *joint* probability density function the estimation of which in general requires an extraordinary amount of information



Assumptions are necessary!

- (a) Ad-hoc distribution selection
- (b) “Stochastic Parametrizations”
- (c) Maximum entropy approach



Ira A. Fulton Schools of Engineering
SEMTE, Faculties of Mechanical and Aerospace Engineering
Structural Dynamics Group



UNCERTAINTY MODELING

(a) Ad-hoc distribution modeling

Use a combination of independence assumptions (joints → marginals) and prescribed distributions (Gaussian/normal, lognormal, uniform,..) to characterize the problem. Issues:

- * many different “types” of assumptions
- * danger of violating physics

Example: Gaussian distribution for stiffness is often accepted if the mean/standard deviation is large (say 10) as probability of negative value is “small”. Yet, mathematically the variance of response is ∞ .

This issue is reflected by the non-convergence of the sample variance as the number of samples increases.

One solution: truncated Gaussian but where to truncate?



Ira A. Fulton Schools of Engineering
SEMTE, Faculties of Mechanical and Aerospace Engineering
Structural Dynamics Group



UNCERTAINTY MODELING

(b) “Stochastic Parametrization”

Represent random variables (processes, etc.) in a “modal” form, i.e. through an expansion on a random basis but with deterministic parameters. Most notable: polynomial chaos (PC) representation, e.g. for a single random variable

$$P = \sum_{l=0} \gamma_l Q_l(V)$$

- * V is a random variable with a specified distribution
- * Q_l are specified functions (orthogonal polynomials)
- * γ_l are deterministic parameters characterizing the random variable P

Still at risk of violating physics unless implemented in V , Q_l , and γ_l .



Ira A. Fulton Schools of Engineering
SEMTE, Faculties of Mechanical and Aerospace Engineering
Structural Dynamics Group



UNCERTAINTY MODELING

(c) Maximum Entropy Approach

The joint probability density needed is not chosen, it is *derived* to maximize the statistical entropy

$$S = - \int_{\Omega} p_{\underline{A}}(\underline{a}) \ln p_{\underline{A}}(\underline{a}) d\underline{a}$$

subject to a series of physical and data matching constraints.

physical constraints: matrix symmetry, positive property, boundedness reflected in Ω .

data matching constraints: mean, standard deviation,

The Lagrange multipliers associated with the data matching constraints become the parameters of the distribution.



Ira A. Fulton Schools of Engineering
SEMTE, Faculties of Mechanical and Aerospace Engineering
Structural Dynamics Group



AN EXAMPLE

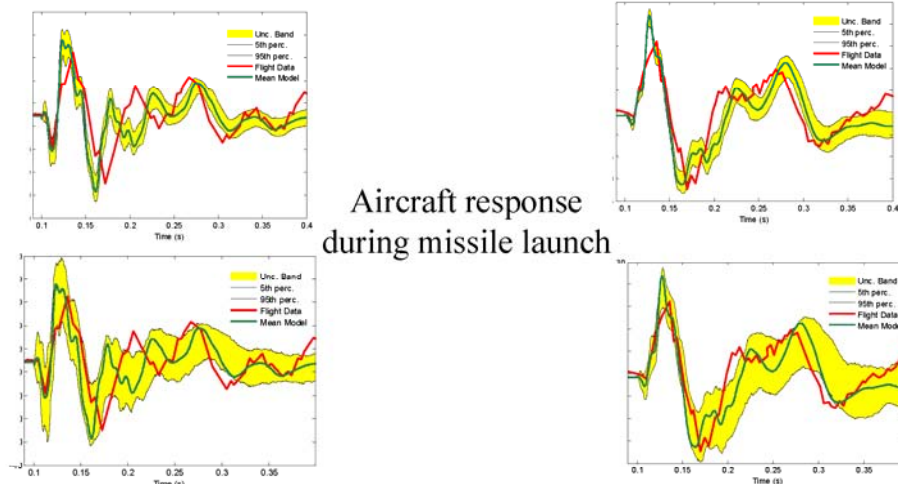

Ira A. Fulton Schools of Engineering
SEMTE, Faculties of Mechanical and Aerospace Engineering
Structural Dynamics Group



4. SUMMARY

The Third International Workshop on Jointed Structures was held in August 2012. At this workshop, 32 researchers from across the world came together to discuss progress made since the previous workshop (in 2009) and to develop a roadmap for the research directions in the area of mechanics of jointed structures over the next five to ten years.

Since the previous workshop, significant progress was made on developing a platform to support the community of researchers for jointed structures. Specifically, a new research committee, the ASME Research Committee on the Mechanics of Jointed Structures, was founded and is being used to foster this research area. Progress on the technical challenges identified at the previous workshop is further detailed in the minutes from this workshop.

The direct outcome from the Third International Workshop on Jointed Structures was a series of challenges that will serve as a roadmap for the next five to ten years of research on the mechanics of jointed structures. These challenges have each been developed through the consensus of the attendees of the workshop, and are designed to address the pressing issues observed in the area of interfacial mechanics for joints, namely: understanding the uncertainty and variation in joints, incorporating high fidelity models into simulations while still generating tractable/efficient solutions, understanding the physical phenomena that leads to energy dissipation in joints, and motivating the new generation of researchers and funding agents of the importance of studying joint mechanics. The specific challenges formulated by the workshop are as follows

1. Round Robin/Benchmark Exercise for Hysteresis Measurements
2. Round Robin/Benchmark for Measurement/Prediction of Dissipation in Standard Joints
3. Methodology to quantify cost benefits of improved joint design
4. Define Mechanisms of Friction (Interface Mechanics)
5. Modelling non-metallics
6. Multiscale modeling framework
7. Definition of variability and uncertainty (linked to Round Robin Challenges 1 and 2, also address how to model in the absence of experimental data)
8. Epistemic and Aleatoric Modeling
9. Time varying model parameters, modeling and experiment “surface chemistry”
10. The derivation of constitutive equations based on physical parameters (including measurement of spatial dependence of key physical parameters)
11. Eventual implementation of prediction methods in commercial numerical codes
12. Develop Statement of Mission and Workshop Report

5. REFERENCES

1. *Report on the SNL/AWE/NSF International Workshop on Joint Mechanics, Dartington, United Kingdom, 27-29 April 2009. Segalman, Daniel J., Bergman, Lawrence A. and Ewins, David J.* Sandia National Laboratories, 2010. SAND2010-5458.

6. DISTRIBUTION

All distributions are electronic unless otherwise noted.

- 1 Dr. Matthew S. Allen
University of Wisconsin-Madison
535 Engineering Research Building
1500 Engineering Drive
Madison, WI 53706, USA
msallen@engr.wisc.edu

- 1 Dr. Edward J. Berger
Department of Mechanical and Aerospace Engineering
School of Engineering and Applied Science
University of Virginia
Charlottesville VA 22904, USA
berger@virginia.edu

- 1 Prof. Lawrence A. Bergman
Department of Aerospace Engineering
University of Illinois at Urbana-Champaign
104 South Wright St.
MC-236
321E Talbot Laboratory
Urbana, IL 61801, USA
lbergman@illinois.edu

- 1 Daniel Brown
DSE/SED/Structural Dynamics
AWE, Aldermaston, Reading, RG7 4PR, UK
Daniel.Brown@awe.co.uk

- 1 Dr. Daniele Dini
Department of Mechanical Engineering
Room 696, Tribology Group
Imperial College London
Exhibition Road, London SW7 2AZ, UK
d.dini@imperial.ac.uk

- 1 Prof. Melih Eriten
University of Wisconsin – Madison
2039 Mechanical Engineering Building
1513 University Ave.
Madison, WI 53706, USA
eriten@engr.wisc.edu

- 1 Prof. David J Ewins
Professor of Vibration Engineering
Imperial College London
South Kensington Campus
London SW7 2AZ UK
d.ewins@imperial.ac.uk
- 1 Prof. Al Ferri
George W. Woodruff School of Mechanical Engineering
Georgia Institute of Technology
Atlanta, GA 30332-0405
al.ferri@me.gatech.edu
- 1 Dr.-Ing. Lothar Gaul
Director Institute of Applied and Experimental Mechanics (IAM)
University of Stuttgart
Pfaffenwaldring 9
70550 Stuttgart Germany
gaul@iam.uni-stuttgart.de
- 1 Prof. Muzio Gola
Politecnico di Torino
corso Duca degli Abruzzi 24
10129 Torino; Italy
muzio.gola@polito.it
- 1 Prof. Hugh Goyder
Cranfield University
Defence Academy of the United Kingdom
Shrivenham, Swindon
SN6 8LA, UK
h.g.d.goyder@cranfield.ac.uk
- 1 Wes Harris
System Dynamics Test and Analysis
Rolls-Royce Corporation
450 South Meridian Street
Indianapolis, IN 46225-1103, USA
wesley.harris@rolls-royce.com
- 1 Prof. David Hills
Department of Engineering Science,
University of Oxford,
Parks Road
OXFORD OX1 3PJ, UK
david.hills@eng.ox.ac.uk

- 1 Philip Ind
Structural Dynamics, Engineering Analysis & Test Group
AWE, Aldermaston, Reading, RG7 4PR, UK
Philip.Ind@awe.co.uk
- 1 Prof. Arif Masud
Department of Civil and Environmental Engineering
University of Illinois, 3110 Newmark Lab, MC-250
205 N. Mathews Ave., Urbana, IL 61801-2352, USA
amasud@uiuc.edu
- 1 Dr. Simon Medina
Tribology Group
Department of Mechanical Engineering
Imperial College London
London, UK, SW7 2AZ
s.medina@imperial.ac.uk
- 1 Marc Mignolet
School for Engineering of Matter, Transport and Energy
Arizona State University
P.O. Box 9309
Tempe, AZ 85287-9309
marc03@asu.edu
- 1 Prof. David Nowell
Dept of Engineering Science
University of Oxford
Parks Rd
Oxford OX1 3PJ
david.nowell@eng.ox.ac.uk
- 1 Dr. Evgeny Petrov
School of Engineering and Informatics
University of Sussex
Brighton BN1 9QT, United Kingdom
y.petrov@imperial.ac.uk
- 1 Prof. D. Dane Quinn
Department of Mechanical Engineering
The University of Akron
Akron, OH 44325-3903, USA
quinn@uakron.edu

- 1 Dipl.-Ing. Pascal Reuss
Institute of Applied and Experimental Mechanics (IAM)
University of Stuttgart
Allmandring 5B
70550 Stuttgart Germany
reuss@iam.uni-stuttgart.de
- 1 Dr. Christoph Schwingshackl
Room 565b, Mechanical Engineering
Imperial College
Exhibition Road
London SW7 2AZ, UK
c.schwingshackl@imperial.ac.uk
- 1 Dipl.-Ing. Bernhard Stingl
Hamburg University of Technology
Institute of Mechanics and Ocean Engineering
Eissendorfer Strasse 42
Room 0517
D-21073 Hamburg, Germany
bernhard.stingl@tu-harburg.de
- 1 Jenny Stroud
Directorate of Systems Engineering
AWE, Aldermaston, Reading, RG7 4PR, UK
Jenny.Stroud@awe.co.uk
- 1 Prof. Pablo A. Tarazaga
Center for Intelligent Material Systems and Structures
Department of Mechanical Engineering
309 Durham Hall, MC 0261
Virginia Tech
Blacksburg, VA 24061, USA
pablotarazaga@vt.edu
- 1 Prof. Alexander F. Vakakis
Department of Mechanical Science and Engineering
University of Illinois at Urbana - Champaign
3003 Mechanical Engineering Laboratory
1206 W. Green Str.
Urbana, IL 61801, USA
avakakis@illinois.edu

1 Prof. Weidong Zhu
Department of Mechanical Engineering
University of Maryland, Baltimore County
1000 Hilltop Circle Baltimore, MD 21250, USA
wzhu@umbc.edu

1 MS 0346 Michael A. Guthrie, 01523
1 MS 0346 Mikhail Mesh, 01523
1 MS 0346 Diane E. Peebles, 01526
1 MS 0346 Michael J. Starr, 01526
1 MS 0346 D. Gregory Tipton, 01523
1 MS 0351 Duane B. Dimos, 01000
1 MS 0384 Justine E. Johannes, 01500
1 MS 0431 Hartono Sumali, 00231
1 MS 0557 Fernando Bitsie, 01521
1 MS 0557 C. Dennis Croessmann, 01520
1 MS 0557 David Epp, 01522
1 MS 0557 Laura D. Jacobs-Omalley, 01521
1 MS 0557 Darrick M. Jones, 01528
1 MS 0557 Randall L. Mayes, 01522
1 MS 0557 Jerry W. Rouse
1 MS 0557 Todd W. Simmermacher, 01523
1 MS 0557 Eric C. Stasiunas, 01521
1 MS 0828 Michael Ross, 01523
1 MS 0840 H. Eliot Fang, 01524
1 MS 0840 John Pott, 01525
1 MS 0845 Joseph Jung, 01542
1 MS 0845 Garth M. Reese, 01542
1 MS 0845 David E. Womble, 01540
1 MS 1070 Matthew R. Brake, 01526
1 MS 9013 James P. Lauffer, 08231
1 MS 9042 Mike L. Chiesa, 08259
1 MS 9042 Michael D. Jew, 08259
1 MS 9042 Daniel J. Segalman, 08259

1 MS 0899 Technical Library, 9536

