

# Home Energy Displays: Consumer Adoption and Response

J. LaMarche, K. Cheney, C. Akers, K. Roth,  
and O. Sachs  
*Fraunhofer Center for Sustainable Energy Systems*

December 2012

## NOTICE

This report was prepared as an account of work sponsored by an agency of the United States government. Neither the United States government nor any agency thereof, nor any of their employees, subcontractors, or affiliated partners makes any warranty, express or implied, or assumes any legal liability or responsibility for the accuracy, completeness, or usefulness of any information, apparatus, product, or process disclosed, or represents that its use would not infringe privately owned rights. Reference herein to any specific commercial product, process, or service by trade name, trademark, manufacturer, or otherwise does not necessarily constitute or imply its endorsement, recommendation, or favoring by the United States government or any agency thereof. The views and opinions of authors expressed herein do not necessarily state or reflect those of the United States government or any agency thereof.

Available electronically at <http://www.osti.gov/bridge>

Available for a processing fee to U.S. Department of Energy  
and its contractors, in paper, from:

U.S. Department of Energy  
Office of Scientific and Technical Information  
P.O. Box 62  
Oak Ridge, TN 37831-0062  
phone: 865.576.8401  
fax: 865.576.5728  
email: <mailto:reports@adonis.osti.gov>

Available for sale to the public, in paper, from:

U.S. Department of Commerce  
National Technical Information Service  
5285 Port Royal Road  
Springfield, VA 22161  
phone: 800.553.6847  
fax: 703.605.6900  
email: [orders@ntis.fedworld.gov](mailto:orders@ntis.fedworld.gov)  
online ordering: <http://www.ntis.gov/ordering.htm>



## Home Energy Displays: Consumer Adoption and Response

Prepared for:

The National Renewable Energy Laboratory

On behalf of the U.S. Department of Energy's Building America Program

Office of Energy Efficiency and Renewable Energy

15013 Denver West Parkway

Golden, CO 80401

NREL Contract No. DE-AC36-08GO28308

Prepared by:

Janelle LaMarche

Fraunhofer CSE

25 First Street, Suite 101

Cambridge, MA 02141

NREL Technical Monitor: Chuck Booten

Prepared under Subcontract No. KNDJ-0-40345-00

December 2012

**[This page left blank]**

## Contents

<b>Contents</b> .....	<b>v</b>
<b>List of Figures</b> .....	<b>vi</b>
<b>List of Tables</b> .....	<b>vii</b>
<b>Definitions</b> .....	<b>viii</b>
<b>Executive Summary</b> .....	<b>ix</b>
<b>1 Introduction</b> .....	<b>1</b>
1.1 Study Approach .....	3
<b>2 Phase I: User Research</b> .....	<b>4</b>
2.1 Consumer Adoption of HEDs.....	4
2.2 Study 1—Early Adopter Survey .....	4
2.2.1 Method.....	5
2.2.2 Results.....	5
2.2.3 Conclusions.....	7
2.3 Study 2—User-Generated Energy Displays .....	7
2.3.1 Method .....	7
2.3.2 Results.....	8
2.3.3 Conclusions.....	10
2.4 Study 3—Focus Groups.....	11
2.4.1 Method .....	11
2.4.2 Results.....	11
2.4.3 Conclusions.....	12
2.5 Summary of Phase I Findings.....	12
<b>3 Phase II: Field Testing</b> .....	<b>14</b>
3.1 Original Test Plan .....	14
3.1.1 Issues Encountered—Participant Uptake.....	14
3.1.2 Issues Encountered—Hardware Reliability .....	16
<b>4 Results of In-Field Pilot Study</b> .....	<b>19</b>
4.1 Data Analysis .....	19
4.1.1 User Feedback on HEDs.....	19
4.2 Ongoing Deployment at Harvard University .....	20
4.2.1 Revised Study Design .....	23
<b>5 Conclusions and Recommendations</b> .....	<b>23</b>
<b>References</b> .....	<b>25</b>
<b>Appendix A: HEM Stimuli Used in Study 1</b> .....	<b>27</b>
<b>Appendix B: Images Used in Study 2</b> .....	<b>28</b>

## List of Figures

Figure 1. TED device.....	1
Figure 2. myEragy Web portal screenshots.....	2
Figure 3. Preferred presentation medium.....	5
Figure 4. User-generated energy display example.....	7
Figure 5. Ideal user display.....	9
Figure 6. Least effective energy visualizations.....	10
Figure 7. Arborpoint Residences.....	15
Figure 8. Memorial Drive Residences.....	17
Figure 9. TED5000 setup.....	17
Figure 10. Percentage change in consumption for TED versus control group.....	19
Figure 11. Botanic Gardens Residences.....	21
Figure 12. eGauge monitoring system.....	21
Figure 13. Data acquisition setup for Botanic Gardens.....	22
Figure 14. Buxton’s (2008) Long Nose Model of Innovation.....	23

*Unless otherwise noted, all figures were created by Fraunhofer.*

## List of Tables

<b>Table 1. HED Adoption Factors .....</b>	<b>4</b>
<b>Table 2. Perceived Usability Results.....</b>	<b>6</b>
<b>Table 3. Length of Use Frequencies by Medium Type .....</b>	<b>6</b>
<b>Table 4. Interview Results .....</b>	<b>8</b>
<b>Table 5. Focus Group Demographics .....</b>	<b>11</b>
<b>Table 6. Participant Outreach and Uptake.....</b>	<b>16</b>
<b>Table 7. TED Troubleshooting .....</b>	<b>18</b>

*Unless otherwise noted, all tables were created by Fraunhofer.*

## Definitions

HED	Home energy display
HEM	Home energy management
MTU	Measuring transmitting unit
TED	The Energy Detective



## Executive Summary

Home energy management (HEM) systems include hardware and software that monitor residential energy consumption. Among these, home energy displays (HEDs) are stand-alone devices that give whole-home electricity consumption feedback to users. Although previous fieldwork on HEDs has shown that they can reduce electricity consumption by approximately 4%–13%, some studies also suggest that the energy savings do not persist, likely because most HEDs do not continue to engage the user over time.

In this project, the research team led by Fraunhofer Center for Sustainable Energy Systems (CSE) focused on investigating the factors influencing consumer adoption of HEDs and evaluating the resulting electricity consumption. We studied households equipped with basic HEDs versus enhanced HEM feedback methods, such as those that include Web portals or alerts. Our hypothesis was that delivering flexible and relatable information to users, in addition to a basic HED, would make feedback more effective and achieve persistent energy savings.

We posed the following research questions to evaluate this hypothesis. In Phase 1, we asked the following:

- What are desirable attributes of HED products?
- How does the design of energy feedback influence user interaction with HEM/HED devices?

Phase 2 sought to answer this question:

- How effective are HEDs in maintaining energy saving consumer behaviors?

In Phase I, we categorized different barriers to HED adoption. We found that many consumers might find HEDs online that are not available for purchase or have vague specifications on pricing and full home requirements for the model. Specifically, we conducted three user research studies to address different aspects of energy feedback preferences and found that users want energy feedback to have the following attributes:

- **Flexibility in Data Access.** In Study 1 we surveyed early adopters and found that users want to be able to access their energy feedback across multiple media.
- **Clarity and Intuitiveness.** In Study 2 we had users build their own mock energy displays. We learned that users want content that is easy to grasp quickly and do not want to spend time reading text or interpreting graphs.
- **Affordability.** In Study 3 we conducted three focus groups and found that users think HEDs are too expensive. There is a significant gap between how much people are willing to pay and how much even basic models cost.

We further found that the design of energy feedback influences the user experience of HEM/HED devices. Users generally interpreted flexible, multimedia feedback as being easier to use and perceived aesthetically pleasing information as being easy to understand.

Our Phase II goal was to recruit a set of 150 households and manipulate the level of user engagement with energy feedback. One group of participants received only a stand-alone HED; another group also received a supplemental Web portal. One of the main challenges in reaching our target sample size was to reconcile the need for an opt-out study design with the networking needs of the devices. This challenge required us to have access to the tenants' Internet connections, raising privacy and ethical concerns from property management. After extensive outreach campaigns in two buildings, only 8% of the buildings' tenant populations opted in to the HED study.

We were unable to evaluate how effective HEDs are in maintaining energy saving behaviors, or if interaction with supplemental feedback methods would be more effective than a HED device alone. For our pilot deployment, we conducted extensive lab and field testing of The Energy Detective (TED), a leading HED model on the market. We encountered several problems, including parts that were unconfigured, gateway miscommunications, failure to post to a data-hosting third party, beta firmware upgrades, and display malfunctions. We concluded that large-scale deployment and maintenance of TED was unmanageable for our research team and moved forward with alternative technical solutions.

Our findings highlight two general issues involved in technology deployment research. First, opt-in versus opt-out study design plays a significant role in the quality of a user sample. Early adopters permeate the current HEM market and research. This self-selection of samples raises concern for drawing conclusions across populations for energy savings based on other opt-in studies. Second, even with a detailed test plan, unexpected factors always arise. Study designs need to be flexible to accommodate restrictions of property management partners while maintaining research integrity.

In light of these challenges, we continue to pursue a modified study at Harvard University, where we are currently investigating the effect of Web versus alert-based energy feedback in lieu of a physical display. Actively reminding participants with alerts can often minimize user effort and engage users meaningfully at critical time junctures.

We recommend that an initiative using HEDs as problem-solving tools could be the most effective use of these products. For example, utility-based rental programs could allow consumers temporary use of an HED to raise awareness of their own household consumption patterns. As an alternative, product refinement in conjunction with a shift to smart metering infrastructure could make the next generation of HEDs much more sophisticated and useful for consumers. Finally, more research is needed to understand the capacity of feedback to increase the motivation of home occupants for saving energy.

## 1 Introduction

Numerous products and companies have emerged over the past decade on the home energy management (HEM) market. Among these, home energy displays (HEDs) help residents visualize, monitor and/or manage electricity consumption (van Dam et al. 2010). HEDs that have typically dominated the market over the last few years are those that generate raw whole-home electricity feedback, such as The Energy Detective (TED) shown in Figure 1.



**Figure 1. TED device**

Feedback is information about the consequences of household actions that affect energy consumption (Spagnolli et al. 2011). This has been shown as an effective method of making energy information visible to consumers and results in energy savings ranging from 4% to 12% (Ehrhardt-Martinez et al. 2010). Other reviews evaluating the effects of feedback information on electricity consumption report savings in the ranges of 5% to 15% (Darby 2006) and 5% to 12% (Fischer 2008). Note, however, that such studies are often conducted with volunteers who may be more motivated than the average homeowner. Furthermore, Wallenborn and colleagues (2011; p. 147) state: “The overall experimental conditions are diverse and not always mentioned (e.g., duration of the experiment, design of the feedback, help and advice from the researchers, price of the monitor).”

In addition, some HED studies tend to monitor consumption only for a short period (less than 6 months). Others suggest that HEDs might not be able to maintain user interest and achieve persistent energy savings. In their 15-month study of 304 homeowners in the Netherlands, van Dam and coauthors (2010) found an initial overall energy savings of 7.8% among their sample after 4 months. In a critical finding, though, these savings were not sustained during measurements taken at the end of the study. These researchers concluded that home energy monitors “drift into the background of people’s attention” after a successful short period of savings and interaction with the device. This highlights the drawback effect, or a “phenomenon in which the newness of a change causes people to react, but then that reaction diminishes as the newness wears off” (Wilhite and Ling 1995).

Hargreaves and co-investigators (2010) found that drop-off in user engagement might result from device complexity and aesthetics. In their study, users who received a more basic but more

attractive HED continued to interact with the devices regularly after the initial feedback phase. They claimed, “The aesthetic appearance of the devices was central to the way in which they were appropriated into the fabric of different households. If the device did not look good enough, it was hidden away and lost its power to communicate” (p. 6118). In other words, the function of the HED was initially able to maintain user interest but only the product form was able to maintain persistence. In general, product form and design has been shown to be a determinant of overall market success (Bloch 1995).

Such findings suggest that user engagement with HEDs could be related to factors such as the way energy feedback is visualized and presented. A better understanding of how these factors might influence the persistence of energy saving behaviors is crucial to understanding and improving the long-term effectiveness of HED technologies. It is possible, however, that basic HEDs alone will not maintain consumer interest. Other third-party options are coming to market that connect to HEDs and transform raw data into more relevant consumer-oriented information. For example, myEragy offers energy and cost breakdowns and allows the user to request alerts when usage exceeds a threshold set by the user (Figure 2). This raises the question of how processed energy feedback might relate to user engagement: Is more tailored and visually appealing feedback more effective at retaining the user’s attention for longer periods of time? Some researchers have classified elements of feedback design (Froehlich 2009), but little fieldwork has been done that compares the consumer response or energy savings of raw versus processed feedback approaches.

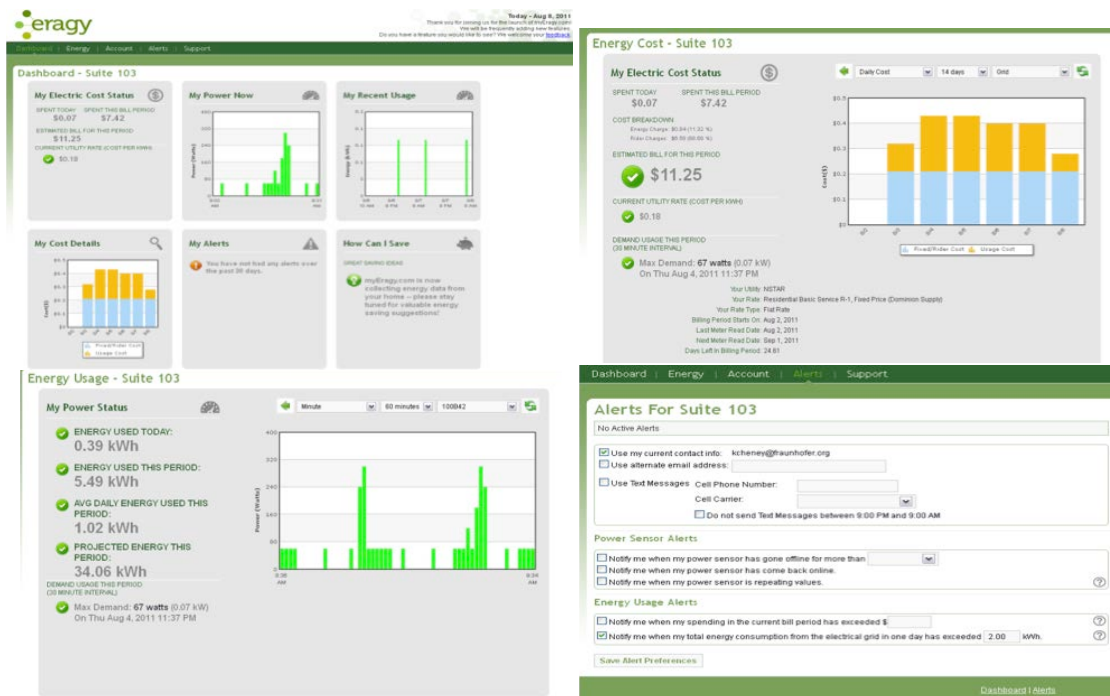

Figure 2. myEragy Web portal screenshots

In this study, the Fraunhofer CSE team sought to determine what users want out of energy feedback to learn how to encourage more habitual use of HEM devices. We hypothesized that

giving users more flexible and relatable information, in addition to a HED, will make feedback more effective and lead to more persistent energy savings.

## **1.1 Study Approach**

To make habitual changes to their behavior, consumers must go through a technology adoption process and be motivated by a device (Rogers 1962). In Phase I of our study, we categorized the barriers the HED adoption process faces, and conducted three user research studies to better understand user perception of HEDs and general HEM preferences. Topics touched on in our user research include the influence of the presentation medium on consumer adoption (Study 1), the influence of aesthetics versus functionality in effective energy visualizations (Study 2), and focus group responses to HEDs across three different age groups (Study 3). Our results speak to how the design of energy feedback influences user interaction with HEM/HED devices.

Phase II of the project was designed to evaluate the real-world effectiveness of 100 HEDs deployed in a multifamily building and to provide a supplementary energy-monitoring Web portal to 50 of these units. Our goal was to evaluate if the consumer-oriented feedback obtained through the Web portal would retain the interest of home occupants for a longer period of time and result in higher overall electricity savings. In this report, we describe several critical issues we encountered, related to participant recruitment and the HED hardware chosen for the study. These issues drastically reduced the study's sample size. We present a limited analysis of user feedback on HEDs after a 3-month pilot installation. Finally, we describe a modified, ongoing study at Harvard University that we developed in light of these issues.

In our conclusions, we discuss the challenges involved in field evaluation of HEM technology, such as self-selection of samples and flexibility in research method and design. Results on consumer interest in HEDs from both phases I and II shape our recommendations on how such devices might be most effective in the current HEM market.

## 2 Phase I: User Research

We aimed to answer two key research questions during Phase I of this project. First, what are desirable HED attributes? Second, how does the design of energy feedback influence user interaction with HEM/HED devices?

### 2.1 Consumer Adoption of HEDs

When consumers purchase new technology, they must perceive the device as something new that will enhance task performance and be free from effort (Davis 1989). HEDs enhance the visibility of real-time electricity consumption, but the extent to which this information is useful for the average energy user is not known. In terms of effort, we take the consumer’s perspective to uncover the barriers to obtaining and using a HED.<sup>1</sup> All of the factors shown in Table 1 could influence HED adoption.

**Table 1. HED Adoption Factors**

<i>Parameter</i>	<i>Example Issues</i>
<b>Pricing</b>	<ul style="list-style-type: none"> <li>• How much does it cost?</li> <li>• Can the consumer calculate return on investment?</li> </ul>
<b>Sophistication</b>	<ul style="list-style-type: none"> <li>• Does the HED come with hardware, software, or both?</li> <li>• Does it require smart metering infrastructure?</li> <li>• Does it need specialized installation?</li> </ul>
<b>User Controls</b>	<ul style="list-style-type: none"> <li>• Is the device easy to use?</li> <li>• Is the device passive or interactive?</li> <li>• Is it controlled via buttons, a touch screen, or additional software?</li> </ul>
<b>Functionality</b>	<ul style="list-style-type: none"> <li>• What feedback information does it provide?</li> <li>• Are the data raw (e.g., real-time consumption) or processed (e.g., comparisons, billing, and goals, among others)?</li> </ul>
<b>Extras</b>	<ul style="list-style-type: none"> <li>• Is the display aesthetically pleasing?</li> <li>• Can it perform any additional functions (e.g., weather or tips on saving energy)?</li> </ul>

We conducted three user research studies to evaluate the user perception of these factors including the medium of presentation, sophistication of feedback design, and pricing.

### 2.2 Study 1—Early Adopter Survey

The first consumers to use and communicate about innovations are typically called early adopters (Rogers 1962). These young, self-motivated consumers often seek out new technologies

<sup>1</sup> See <http://cse.fraunhofer.org/publications/home-energy-management-products-and-trends/> for an internal report detailing products currently on the HEM market.



and others may look to this group to see how a new product or idea works. Our goal in Study 1 was to investigate HEM technology adoption across different presentation media, in an effort to understand how HEDs might differ from feedback presented via Web portal or smartphone application.

### 2.2.1 Method

We recruited 46 volunteers via social media to complete an online survey ( $M_{age} = 35$ , range 21–67, 74% homeowners). Participants were professionals working in the local research community and considered early adopters because of mean age, level of education, and interest in technology research. Seven random participants were chosen by lottery to win an incentive after data collection was completed (up to \$20 at Amazon.com).

Participants viewed 12 HEM systems across three presentation media (four HED exemplars, four Web portal exemplars, and four smartphone application exemplars; see Appendix A for thumbnails). Participants were asked which medium they preferred overall. In addition, for each individual system, they were presented with a representative image of the user interface and asked three yes or no questions that address different facets of perceived usability:

- Is it nice to look at?
- Is it easy to understand?
- Does it make you want to explore more?

Participants were also asked to rate how long they would be willing to use each system in minutes. This hypothetical length-of-use data served as a loose metric of technology adoption.

### 2.2.2 Results

We found multimedia HEM to be the most preferred method of feedback (Figure 3).

**Which medium of home energy management do you think you'd most prefer?**

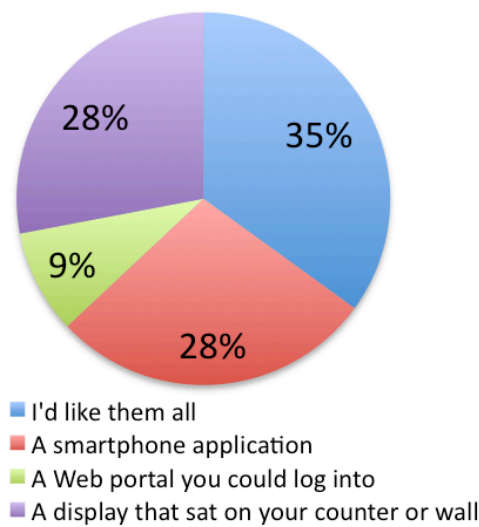

**Figure 3. Preferred presentation medium**

For the perceived usability analysis, we averaged the percentages of yes or no responses for our three questions and compared them across media using a z-test for the difference between proportions. Table 2 summarizes our findings, with the last column indicating statistical significance of the proportions of yes/no responses we collected.

**Table 2. Perceived Usability Results**

<i>Medium</i>	<i>Average (look, ease, explore)</i>	<i>%</i>	<i>z-value</i> <i>z crit = ± 1.96</i>	<i>* p &lt; 0.05</i>
<b>HED</b>	Yes	63	1.80	n.s.
	No	37	-1.80	n.s.
<b>Web</b>	Yes	70	2.66	*
	No	30	-2.66	*
<b>Phone</b>	Yes	61	1.49	n.s.
	No	39	-1.49	n.s.

Web portals are the only energy feedback method where survey responses significantly differed from chance (this effect stems from higher yes responses overall for the “Is it nice to look at?” and “Does it make you want to explore further?” questions). This finding could relate to overall screen size and content ratio, but it also indicates the need for better user interface design for HEDs and smartphone applications.

In addition, we asked respondents how presentation medium affects how long they would be willing to interact with the HEM systems. Table 3 summarizes our findings.

**Table 3. Length of Use Frequencies by Medium Type**

<i>Time willing to spend using</i>	<i>HED</i>	<i>Web</i>	<i>Phone</i>
<b>None</b>	7	4	14
<b>1–5 min</b>	30	24	25
<b>10–15 min</b>	9	16	6
<b>More than 15 min</b>	1	2	1



The highest frequency counts for all media fall within 1 to 5 min; this was expected based on previous estimates (Tendril 2012; Froehlich 2010). We observed, however, that many participants are willing to spend more time with Web portals (16/46), and less time with smartphone applications (14/46) than expected. These distributional differences are statistically significant ( $\chi^2(3) = 24.2, p < 0.001$  and  $\chi^2(3) = 16.2, p < 0.01$ , respectively).

### 2.2.3 Conclusions

HED adoption could be more successful if supplemented by other media such as Web portals. Users are also more willing to spend time with an energy feedback device if it rates highly on usability (i.e., presents information that is well designed, simple, and attention grabbing). Among these usability dimensions, Web portals were preferred compared to HEDs and smartphone applications.

## 2.3 Study 2—User-Generated Energy Displays

Our goals in Study 2 were to evaluate the influence of energy feedback design versus its functionality. We did this by bringing in users to build mock HEDs and interview them about what energy visualizations they found to be most effective.

### 2.3.1 Method

We recruited 20 new participants via a community mailing list, flyers posted in local businesses, and Craigslist ( $M_{age} = 39$ , range 22–73, 70% homeowners). All participants came to our testing facility in Cambridge, Massachusetts, and were paid \$20 for approximately 1 hour of their time. Using screenshots from various energy feedback interfaces, we created 45 laminated “building blocks” displaying an energy-related graph, image, or message in one of seven categories: real-time, history, goals, social, comparisons, extras, tips, and display (see Appendix B for category exemplars). Participants were asked to choose from these pieces and to assemble their own interface in a 15½ in. × 13½ in. taped-off area on a table (Figure 4).



Figure 4. User-generated energy display example

After a participant had made his or her selections, they were asked the following questions:

- Are you familiar with energy saving display technologies?
- Would you use them?
- Did design play a role in the display you created today?

### 2.3.2 Results

We performed a category analysis by calculating the proportion of exemplars for each category that were picked more than four times across participants (see the data in Appendix B). Categories that were generally preferred include goals, history, and social. This is consistent with the idea that processed data might be more valuable to users than real-time consumption (raw data) alone.

Two researchers transcribed and coded audio interviews. Each researcher independently coded user interviews and marked their explanations as design-driven<sup>2</sup> or functionality-driven. After coding the transcripts, comparisons indicated 84% reliability between the two researchers. Table 4 summarizes our results.

**Table 4. Interview Results**

<i>Question</i>	<i>Yes (%)</i>	<i>No (%)</i>	<i>Other</i>
<b>Are you familiar with energy-saving display products?</b>	45	35	-
<b>Would you use them?</b>	56	6	Unsure = 39%
<b>Did design play a role in the display you created today?</b>	85	15	-

Participants were asked to perform a post hoc “think-aloud” procedure to help us better understand why they chose certain display components. Although participants said that design played a role in their choices, interview coding reveals that 74% of subjects mentioned ease of use as a primary motivator. The representative responses below mention the importance of being easy to see and grasp feedback quickly:

“It doesn’t have a lot of extra graphics to interpret, so if you just glance at it, you can figure out what it says really quickly.”

“Because the design and the information is easy to read across the board.”

<sup>2</sup> Note that for the purposes of this study, design refers to aesthetics.

“The visual is very good because you can tell immediately what is going on. You know red is bad and green is good. It’s very intuitive.”

“I want bold graphics, things that you don’t have to read.”

To explore the importance of both aesthetics and ease of use on effective energy visualizations, we had a second group of 13 participants rate the same 45 images on a five-point scale for two questions: Is it nice to look at? Is it easy to understand? By averaging the two, we were able to create a general engagement rating (Appendix B). This rating was cross-referenced with the items chosen during the display-building task, highlighting the pieces that users prefer on a number of design dimensions.

We found overlap between images that were picked frequently during the display-building task and those that had high engagement ratings. We were able to isolate four winning visualization strategies, which are arranged into an ideal user display in Figure 5. The arrangement of these visualizations follows the most common spatial placement by our users.

1. Sleek header that summarizes critical home information
2. Minimalist real-time gauge with cost monitoring and high visual contrast
3. Color-based goal tracking calendar with personal baselines
4. Simple thermostat with controls.



Figure 5. Ideal user display

We found one discrepancy for user alerts. Because alerts can often be part of display settings, they might not be well visualized, but they are highly regarded for their value. During the interview, alerts were mentioned frequently in regard to missing functionality in HED products that users would like to have. For example, one respondent commented, “Actually it would be

good if there was an alert system that would let you know how you're doing and email or change colors or something that would let you know that you're exceeding your target or your average."

Overlap was also found for four pieces that were never chosen and had the lowest engagement rating (Figure 6):

1. Real-time monitor with raw data view
2. Text-heavy tips
3. Chronological energy comparisons for day, week, and month
4. Economic impact bar graph with social component.

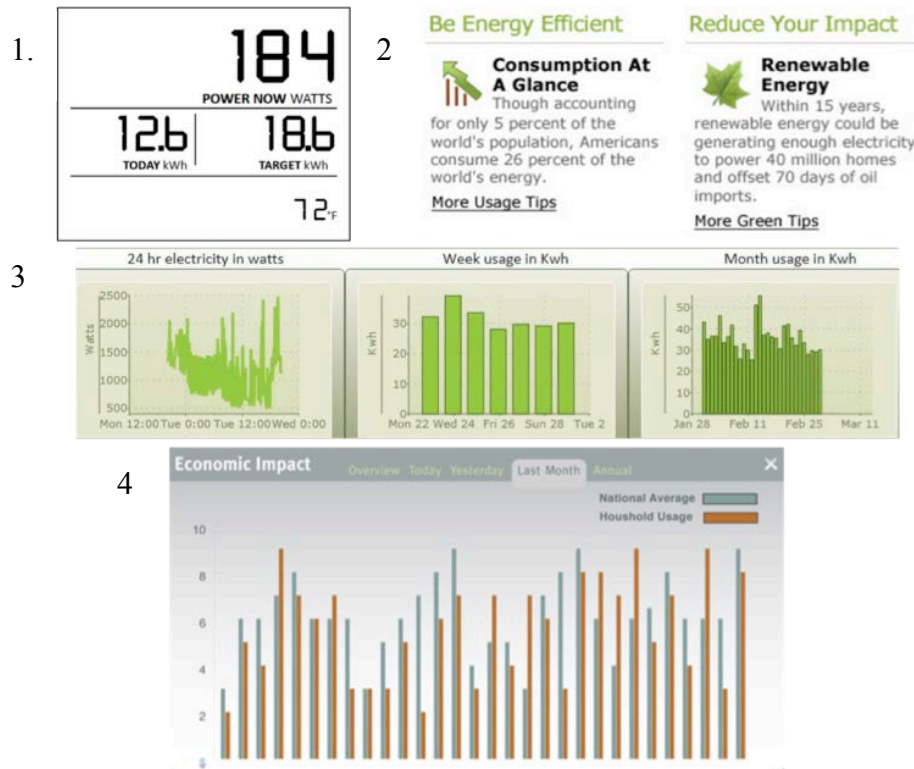

**Figure 6. Least effective energy visualizations**

There are differences between the energy visualizations in Figures 5 and 6. The most effective visualizations offer minimal yet intuitive designs and bright attention-grabbing colors. This is in line with our findings that ease of use is a key factor in energy feedback. In contrast, the least effective visualizations are those that are busy to the eye and would require that users spend time interpreting graphs or reading. Importantly, one of the least preferred visualizations, shown in Figure 6, is very similar to TED's digital interface. This raw data look is typical in some of the leading HEDs on the market today.

### 2.3.3 Conclusions

In general, users choose energy feedback that is more processed (i.e., personal and social comparisons). This could reflect the user relevance of such feedback compared to raw whole-

home electricity monitoring. In addition, ease of use was found as a key determinant of effective energy visualizations rather than aesthetics or functionality alone.

## 2.4 Study 3—Focus Groups

In Study 3, we recruited three groups of users to discuss HEDs and learn more about the viability of consumer adoption of these devices particularly as it relates to pricing. We separated participants into age categories to investigate if there are differences in potential of technology adoption for younger versus older adults (see Anderson and White 2009 for a similar methodology).

### 2.4.1 Method

We recruited 18 people (9 men, 9 women) from the local community and Craigslist and divided them by age into three hour-long focus groups separated by age. Table 5 shows basic demographics of our groups.

**Table 5. Focus Group Demographics**

<i>Focus Group</i>	<i>Mean Age (Range)</i>	<i>Rent, Own</i>	<i>Male, Female</i>
<b>Under 30</b>	27 (23–29)	5, 2	4, 3
<b>30 to 50</b>	41 (35–48)	1, 4	2, 3
<b>Over 50</b>	64 (54–71)	0, 6	3, 3

We made audio recordings of the group discussions and then transcribed the audio recordings for analysis. In each focus group session, we explained HEM products and showed participants pictures of HED products. Participants were asked the following questions:

- Have you heard of HEDs before? Would you want to use them?
- How much would you be willing to pay for a HED?
- What display medium would you prefer?
- How much time would you spend using an energy feedback device?

### 2.4.2 Results

Across all age groups, we found that most people had not heard of HED technologies before. In terms of price, no one was willing to pay more than \$50, with a significant proportion stating that they would only want a device if they did not have to pay at all. Participants perceived the displays as problem-solving tools that they would use temporarily and no longer need after they had lowered their energy use. Consistent with their unwillingness to pay full cost for the displays, a few mentioned that they would rather rent or borrow the device and return it once they had learned from it. Finally, participants wanted the feedback to be straightforward enough that they could understand it at a glance and expected to spend less than 5 minutes a day viewing the device.

We did not find many differences between age groups and HED preferences, except for openness to other HEM feedback media such as smartphone applications. The youngest group thought that apps were “ideal” and seemed more interactive than the static displays. Many did not see the need for a physical device at all. Our oldest group, on the other hand, was more skeptical about the reliability of monitoring away from the home, and thought that their interaction with supplemental feedback methods would be more infrequent than with a HED device.

### 2.4.3 **Conclusions**

Users across all age groups agree that HEDs cost too much, and are doubtful that HEDs can pay for themselves in energy savings. This result is broadly consistent with Southern California Edison (2012), who found that of 42% of participants interested in using an HED, 46% would take a free HED, 39% might pay \$49, 25% might pay \$99, and 12% might pay \$199. Considering that most currently available HEDs cost \$100–\$300, current market solutions are clearly too expensive.

## 2.5 **Summary of Phase I Findings**

In Phase I, we uncovered general barriers that a consumer would encounter when trying to obtain a HED, and compiled data from three studies to evaluate the influence of presentation and design factors on HEM feedback preferences.

In exploring what users want out of HEM technologies, we found three key results:

- **Flexibility in data access.** Users want to be able to access their energy feedback across multiple media.
- **Clarity and intuitiveness.** Users want content that is easy to grasp quickly, and do not want to spend time reading text or interpreting graphs.
- **Affordability.** Users think HEDs are too expensive, and there is a significant gap between how much people are willing to pay and how much even basic products cost.

In evaluating how the design of energy feedback influences user interaction with HEM/HED devices, we found that users interpret data flexibility as being easier to use, and perceive aesthetically pleasing information as being easy to understand.

These findings stress the importance of user-centered design research in the field of energy feedback (LaMarche and Sachs 2011), and consistent with Fischer (2008), who suggests that barriers to HEM adoption can be overcome by conveying simple, actionable information to home energy users for each step of the process—from finding product specifications to post-purchase operability.

Although these are essentially indirect methods, they shaped the field deployment portion of this study, supporting our hypothesis that HEDs alone might not be effective in engaging users and changing energy behaviors. The consumer models of HEDs on the market today typically do not offer users flexibility or processed feedback beyond real-time consumption levels. We incorporated these as variables into our Phase II study design to get a more comprehensive picture of how users engage with and respond to HEM in a real-world application. In particular,



in Phase II we sought to understand how raw versus processed energy data influence usability and user engagement with feedback.

### 3 Phase II: Field Testing

We aimed to answer one key research question during Phase II of this project: How effective are HEDs in maintaining energy saving consumer behaviors? This investigation of HED effectiveness was stopped because we encountered a number of issues during our pilot deployment phase.

#### 3.1 Original Test Plan

Our Phase II goal was to recruit 150 households and manipulate the level of user engagement with energy feedback. This sample size was specified through a prior power analysis given an 8% expected energy savings (van Dam et al. 2010) and 80% power.

For this study, we define low engagement as providing kilowatt-hour or dollar per hour raw data, and high engagement as energy-related information beyond kilowatt-hours or dollars per hour (e.g., historical graphs or comparisons [processed data]). In the original study design, 50 participants in a “low engagement” group were to receive a market-leading HED with raw electricity feedback, 50 participants in a “high engagement” group were to receive additional processed feedback in the form of a Web portal, and 50 participants were to serve as a control group.

We chose Energy, Inc. (TED hardware; refer to Figure 1) and Eragy (myEragy software; see Figure 2) as partners in our field-testing phase. These were chosen because the TED display is a highly popular model on the consumer market today, and the myEragy Web portal is compatible for data posting with TED.

Our team developed and submitted all recruitment and user survey materials to the Central Department of Energy Institutional Review Board and received approval in August 2011.

We targeted multifamily buildings around Boston, Massachusetts, to acquire the sample size needed. These buildings also have similar appliances, heating systems, and building envelope characteristics that minimize confounding variables in measuring residential energy consumption.

In the sections that follow, we describe two critical issues we encountered during the deployment of this study design: participant uptake and hardware reliability.

##### 3.1.1 *Issues Encountered—Participant Uptake*

Our approach to field deployment was to find a property management partner of a building or buildings that met a number of specific building constraints we considered crucial for study implementation (i.e., more than 100 units, Internet access in all units, and submetering of electricity consumption). One of the main challenges in reaching our target sample size was to reconcile the need for an opt-out study design with the networking needs of the TED devices. This challenge required us to have access to the tenants’ private Internet connections/routers, which raised privacy concerns from the property management. As a result, we employed an opt-in scenario for subject recruitment in two buildings in which management was interested in the project.



Location 1 was the Arborpoint Residences at Station Landing (Figure 7).<sup>3</sup> The site comprises three buildings built in 2006 in Medford, Massachusetts, with a total of 460 market-rate units ranging from studios to three-bedroom apartments. One of the three buildings also maintains a green initiative.



**Figure 7. Arborpoint Residences**

We began recruitment at Arborpoint by distributing flyers under the door of all 460 apartments. Tenants had to sign the flyer and return it to the property management office, which was located right outside all three buildings. After 2 weeks, initial signups totaled 17 units. We distributed a second set of flyers, changing the flyer design slightly to emphasize participant incentives. After 1 more week, signups totaled 28 units. Because this number was significantly lower than the sample size required for our study, three researchers began outreach in the building lobbies. One evening from 4:00 p.m. to 7:00 p.m., one researcher campaigned in each lobby. Posters of the example hardware that emphasized participant incentives were created and candy was distributed to raise general interest in the outreach campaign. At the end of this outreach, 39 tenants had signed up for the study (for pilot results at Arborpoint see Section 3.2).

Location 2 was the 808 Memorial Drive residences (Figure 8).<sup>4</sup> This site includes two buildings renovated in 1998 in Cambridge, Massachusetts, with a total of 300 units (50% affordable housing and 50% market rate). The units range from one to three-bedroom apartments.



**Figure 8. Memorial Drive Residences**

---

<sup>3</sup> See <http://www.arborpoint.com/Medford-MA-Apartments/Station-Landing/> for more information.

<sup>4</sup> See <http://www.808memorialdrive.com/> for more information.

We initiated the same recruitment strategy used at Arborpoint at the Memorial Drive Residences, with two rounds of flyer distribution and lobby outreach approximately 3 weeks after flyers were distributed. Again, after a vigorous recruitment campaign, only 25 tenants signed up for the study. This highlights an important study finding. Using an opt-in recruitment strategy, only about 8% of a building’s tenant population opted to receive a free HED as part of our study. Table 6 summarizes these results.

**Table 6. Participant Outreach and Uptake**

<i>Name</i>	<i>Size</i>	<i>Outreach</i>	<i>Number of Signups</i>	<i>% Population</i>
<b>Arborpoint</b>	460	Flyers twice, lobby outreach	39	8.5%
<b>Memorial Drive</b>	300	Flyers twice, lobby outreach	25	8.3%
<b>Total</b>	<b>760</b>	-	<b>64</b>	<b>8.4%</b>

The challenges we faced in recruiting subjects for this study, and across different demographic segments, reinforce what users said in Phase I of the study: They are not particularly interested in the type of energy feedback offered by HEDs. Considering that we were offering the display at no charge with participant incentives, and that we were also hiring and paying for the electrician needed for installation, such low uptake provides further evidence that stand-alone HEDs may not be a scalable market solution.

**3.1.2 Issues Encountered—Hardware Reliability**

We purchased TED5000-C units and 50 TED5000-G units for deployment. Figure 9 shows how the three essential pieces of the TED5000 device (measuring transmitting unit [MTU], gateway, and display) connect to monitor energy usage.



**Figure 9. TED5000 setup**

Preliminary laboratory and field testing showed a high rate of failure in both settings with a large variety of failure modes (Table 7).

We used approximately 40 TED devices for laboratory testing. This consisted of wiring the MTUs to extension cords and plugging them into miscellaneous loads (e.g., computers and water coolers), and gateways into outlets and our internal office network. We found both improperly configured units and mislabeled displays (e.g., the sticker serial number did not match the device serial number).

Initial laboratory attempts to configure and post TED data to the Eragy Web portal were generally successful. We did, however, encounter regular issues with unplugging the TEDs and getting them to reboot reliably and repost data after initial configuration. Our testing also showed that the gateway often had problems obtaining IP addresses from routers.

**Table 7. TED Troubleshooting**

TED #	Currently Working?	Hardware and Communication				Posting to Eragy	
		Display	Gateway	Communication (MTU→ Gateway)	Others	Initial Runs	Firmware Upgrade
6	No	Failure		Failure			
8	No			Failure			
9	No			Failure			
10	No		Failure				
11	Working					Failure	Success
15	No					Failure	Failure
16	Working					Failure	Success
17	Negative readings					Success	
20	No	Failure				Failure	Failure
21	Working					Failure	Success
22	No					Failure	Failure
33	No				Router Connection Failure		
34	Working					Success	
27	No					Failure	Failure

From the laboratory-tested samples, we chose the 15 most reliable units for pilot field deployment. These were installed in the Arborpoint residences (Figure 7) from March 2012 through the first week of April 2012. After initial installation, we found that 11 of the 15 deployed units stopped posting to *Eragy*, most after a very short period of successful posts. After working with TED engineers, and receiving a new beta firmware upgrade, we repeated more extensive in-house testing, and upgraded the units in the field. Even with the upgrade, however, only three units were successfully posting consistently (one unit stopped functioning during the upgrade process). Aside from the installation and networking issues, we also experienced display malfunctions and data processing errors. Four of 15 users noted that their display had shown a constant value even while they were using major appliances.

We concluded that large-scale deployment and maintenance of the TED devices was unmanageable for our deployment and moved forward with alternative technical solutions. It is possible that this consumer-grade product would behave differently in other deployment environments. Researchers in other studies, however, have encountered similar problems. Wallenborn and colleagues (2011) mention that the regular market models of HED chosen for their study were hard to install and not very user friendly.

## 4 Results of In-Field Pilot Study

### 4.1 Data Analysis

Working TED displays were installed in 12 residential units. Because of the networking issues, none of these units were successfully connected to *Eragy* for our data collection purposes. Weekly meter readings were taken on experimental units as well as control units that were matched for size. Weekly changes in energy consumption were derived from the meter readings by subtracting the readings of the previous week from the current week of reading. Change in consumption reflects the proportion of this difference. The results are plotted in Figure 10.



**Figure 10. Percentage change in consumption for TED versus control group**

Data from the first 3 months with our small pilot sample is not statistically significant ( $t(22) = 1.72, p = 0.28$ ). Households using an HED within the first 3 months show no significant difference in electricity consumption compared to control households without energy feedback.

#### 4.1.1 User Feedback on HEDs

We gathered user feedback on HED usage by email. Seven of our users in the pilot study gave us general feedback on the displays. Two said they still look at the display daily:

“I find it very useful. Sometimes it reminds me to turn off my stove and A/C when I see high numbers on the display.”

“Yes, but an app would be much better. Also explanations of how to use the information to make our home more energy efficient would be helpful.”

Five mentioned that they no longer interact with the display for various reasons:

“We still have the display out and I look at it somewhat often. However, as I had mentioned when you came to do the update, it always displays the same information. It always says we are using 130.6 voltage and \$0.03 (even when the washer or microwave is on), it also always says we are projected to spend \$4.24/month (which would be nice, but is obviously not the case, the bill is closer to \$28 each month). I still think the device would be useful if I felt the information displayed was accurate in any way. I think the aesthetics are great, it’s not obtrusive in anyway.”

“My apartment was really small so I learned the energy use combinations really quickly.”

“Once we figured that out over the first week, not much new info since.”

“No, we don’t use it anymore. It was not a very convenient sight for the members of the house. The readings were too high! It has to be more close to my estimates. If it is closer and more precise, I would definitely look at it. It was showing a very high bill for the month!”

“Now I glance at it maybe once per week. I soon came to the realization that since I live in an apartment that’s already designed to be efficient that there’s not really too much I can do to have any real impact on my energy costs/usage without sacrificing personal comfort.”

These admittedly limited user responses indicate that they are quick to stop learning new information from the HED device. It might also corroborate both van Dam and coauthors’ work (2010) and the drawback effect where the novelty of a new device results in an initial user reaction that diminishes quickly. It should be clear that there are both hardware reliability and engagement issues, even after 3 months with a small, albeit strongly self-selecting, pilot sample.

In Phase I, we found support for user alerts as well as presenting feedback through multimedia applications, such as an energy-monitoring Web portal. When the behavior tracked might be sporadic over the long term, as in the case of repeated monitoring of electricity usage, allowing users to get their own feedback or providing alerts to users might increase behavioral change. In the first case, effectiveness could drop off after an initial period, and users could become less motivated to log in to receive energy information. In contrast, actively reminding participants with alerts often can minimize user effort and engage meaningfully at critical junctures (i.e., visual prompts can function as triggers for behavioral response). Behavioral change using triggers has been highly successful in the field of persuasive technology (Fogg 2003). We incorporate these insights into our ongoing study efforts, described next.

## **4.2 Ongoing Deployment at Harvard University**

In May 2012, we partnered with managers of graduate and family housing at Harvard University. The Botanic Gardens was built in 1949, with major renovations in 1993.<sup>5</sup> The site houses seven buildings in Cambridge, Massachusetts, with a total of 117 units ranging from one to two bedrooms (Figure 11).

---

<sup>5</sup> See <http://www.huhousing.harvard.edu/BotanicGardensMA/index.aspx> for more information.





**Figure 11. Botanic Gardens Residences**

#### **4.2.1 Revised Study Design**

In the new study design, approximately 35 participants will be offered a log-in for a free energy monitoring Web portal, 35 participants will be offered weekly alerts on their consumption, and 35 participants will serve as a control group. The first two groups are analogous to the low and high interactive groups from the original study design. Our hypothesis is that participants who receive energy feedback through regular alerts will be more successful in maintaining energy savings than participants who use the Web portal. We are also interested in the initial period of interaction with Web portal features and the overall change in this interaction over the long term.

We modified the study design in two ways to remedy both issues encountered during the Arborpoint and Memorial Drive residences pilot deployment, and to work with constraints imposed by Harvard University.

First, tenants at Botanic Gardens do not pay electricity bills and Harvard University requested that we omit any cost-related energy feedback. Although this factor is not indicative of the average consumer, it allows us to better isolate the effectiveness of the feedback method alone (e.g., presentation medium and frequency). Because TED's display contains this information and was found to be problematic in our previous tests, we changed the study hardware to eGauge (Figure 12).<sup>6</sup>

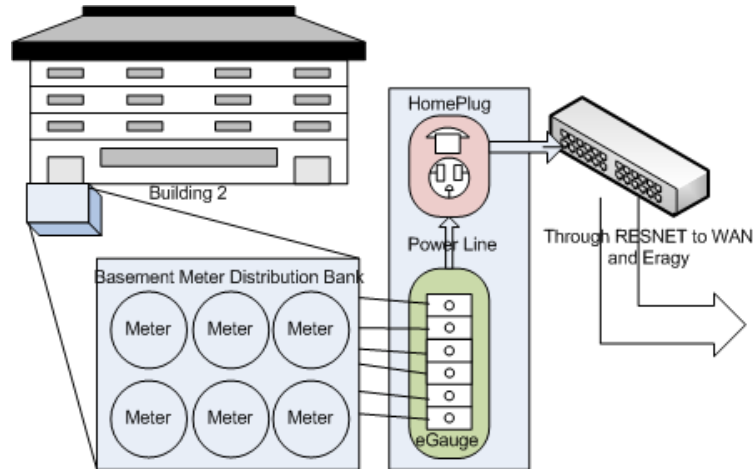

**Figure 12. eGauge monitoring system**

---

<sup>6</sup> See <http://www.egauge.net/> for more information.

This product is usually used in more commercial settings, but retains compatibility with the Eragy Web portal. Critically, the eGauge does not have a physical user interface. Insights from Phase I, as well as earlier recruitment challenges, suggest that cutting out the display might be appropriate. Figure 13 shows the hardware and data acquisition setup for the Botanic Gardens study.



**Figure 13. Data acquisition setup for Botanic Gardens**

Secondly, the eGauge systems will monitor 105 units at the Botanic Gardens complex even though subject recruitment will still take place. We hope for a higher uptake with this population given their connection to the university. We have also acquired permission to contact tenants at subsequent times during the academic year to give us a better understanding of participant uptake as an important study variable, particularly with those tenants who are not initially interested in activating the feedback system.

In addition to energy usage data, we will monitor and analyze the nature of participant interaction with the Eragy system by monitoring the length and frequency of log-in, as well as click patterns. Surveys administered in the middle of the academic year will explore variables such as conscientiousness and intrinsic versus extrinsic motivation to learn about persistence.

The hardware was installed in August 2012. Of the 105 monitored apartments, 46 participants have signed up to receive the myEragy Web portal, and 59 serve as our control group. Tenant feedback was initiated on October 15, 2012, and the study is currently running through the 2012-2013 academic year.



## 5 Conclusions and Recommendations

We investigated consumer adoption and response to HEDs, products that aim to help households to visualize energy consumption. The conventional argument is that providing real-time feedback on energy consumption and costs will motivate users to change their behavior. Although this could be true in some experimental settings, in the real world HEDs face many barriers to widespread, effective use by consumers including cost, ease of use, and product design. Because HEDs are a relatively young technology, this is in line with Buxton’s (2008) Long Nose Model of Innovation (Figure 14). In this model, innovation occurs over a longer time period, taking up to decades for a new product class to gain traction in a consumer market. Therefore, in the case of HEDs, product function and form will likely need to be refined and enhanced before HEDs become a scalable market solution.

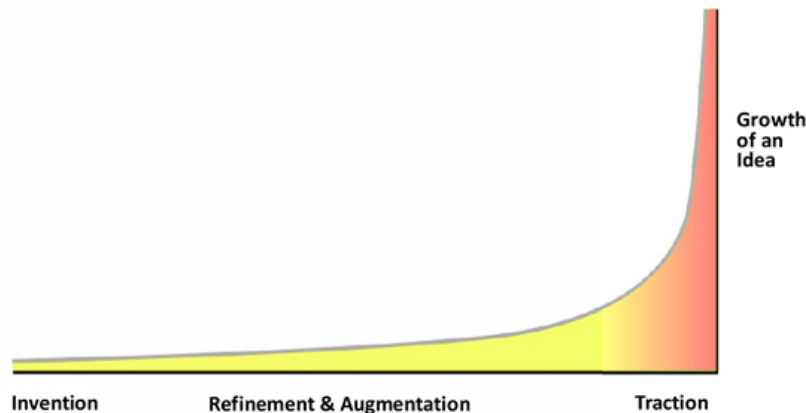

**Figure 14. Buxton’s (2008) Long Nose Model of Innovation**

Our findings support the need for HED product refinement. We chose one of the most common and established HED market solutions for our research and found that the hardware did not work reliably in a multifamily field-deployment environment, even with extensive testing and troubleshooting. Furthermore, current market models typically yield whole-home energy consumption data. This raw feedback approach is not aligned with user preferences. Users in Study 1 wanted an intuitive feedback approach and showed a preference for supplementing HED feedback with Web-based applications. Users in Study 2 chose more processed feedback visualizations. In our field deployments, we encountered many problems with participant uptake even when it was easy for households to obtain a free TED display. This suggests that simply showing consumers their current energy consumption is not sufficiently compelling to achieve widespread product adoption.

In this study, we were unable to determine if interaction with supplemental feedback methods is more effective than using a HED device alone. We did find, however, that the types of feedback that might optimize user engagement include processed (consumer-oriented) data that are presented in a clear and “glanceable” manner. This makes multimedia feedback approaches, such as Web-based interfaces and alerts, viable methods that need to be further explored as substitutes for physical displays. As we transition to a smart grid, these products could potentially be much more convenient for the average consumer because enhanced wireless communications can allow software applications to take the place of labor-intensive hardware setups.

Our findings highlight a critical issue involved in technology deployment research—self-selection of samples. The way people are recruited (opt-in versus opt-out) plays a significant role in the size and quality of the user sample. We have seen that early adopters permeate both the current HED/HEM market as well as current research studies. Even though these subjects are often enthusiastic about energy saving technology research, our study suggests that their opinions and behaviors cannot be readily generalized, raising some doubt if savings that have been shown in other studies can be replicated in the general population (lack of real-world applicability).

We believe that an initiative to use stand-alone HEDs more as problem-solving tools, not as long-term consumer investments, could be effective in raising consumer awareness and prompting positive changes to energy behaviors. After a habit is formed, an individual might not need feedback at all. Our focus group subjects and user feedback on the TED display support such a method. We recommend that work should be done in this area to see if this approach can gain traction (e.g., utility-based rental programs). In addition, reviewing library HED rental programs might help to elucidate this approach.

As another alternative, smart meters could make HEDs more viable because they will be able to communicate real-time pricing information. This would enable equipping the next generations of HEDs with more advanced functions such as disaggregation of the whole-home electricity signal by “top energy users” or by room. This would allow more user-relevant home comparisons and could be the needed catalyst for identifying and motivating actionable energy saving behaviors. To fully capitalize on this opportunity, more research is needed to understand the capacity of feedback to increase home occupants’ motivation for saving energy.

## References

- Anderson, W.; White, V. (2009). *Exploring Consumer Preferences for Home Energy Display Functionality: Report to the Energy Saving Trust*. Bristol: Centre for Sustainable Energy.
- Bloch, P. (1995). "Seeking the Ideal Form: Product Design and Consumer Response." *Journal of Marketing* (59); 16–29.
- Buxton, B. (2008). "The Long Nose of Innovation." *Business Week*, January 2, 2008.
- Darby, S. (2006). *The Effectiveness of Feedback on Energy Consumption: A Review for DEFRA of the Literature on Metering, Billing and Direct Displays*. Environmental Change Institute, University of Oxford.
- Davis, F.D. (1989). "Perceived Usefulness, Perceived Ease of Use and User Acceptance of Information Technology." *MIS Quarterly* (13); 319–340.
- Ehrhardt-Martinez, K.; Donnelly, K.A.; Laitner, J.A. (2010). "Advanced Metering Initiatives and Residential Feedback Programs: A Meta-Review for Household Electricity-Saving Opportunities." Prepared for the American Council for an Energy-Efficient Economy, Washington, DC.
- Fischer, C. (2008). "Feedback on Household Electricity Consumption: A Tool for Saving Energy?" *Energy Efficiency* (1:1); 79–104.
- Fogg, B.J. (2003). *Persuasive Technology: Using Computers To Change What We Think And Do*. Amsterdam: Morgan Kaufmann Publishers.
- Froehlich, J. (2009). "Promoting Energy Efficient Behaviors in the Home through Feedback: The Role of Human-Computer Interaction." HCIC [Human Computer Interaction Consortium] 2009 Winter Workshop Boaster Paper, Colorado.
- Froehlich, J. (2010). "Moving Beyond Line Graphs: A (Brief) History and Future of Eco-Feedback Design." Presented at the 4th Annual Behavior, Energy, & Climate Change Conference, November 14–17, Sacramento, California.
- Hargreaves, T.; Nye, M.; Burgess, J. (2010). "Making Energy Visible: A Qualitative Field Study of How Householders Interact with Feedback from Smart Energy Monitors." *Energy Policy* (38); 6111–6119.
- LaMarche, J.; Sachs, O. (2011). "Designing Interfaces for Home Energy Users: A Preference Study." *Posters, Part I, HCII 2011, CCIS 173*, edited by C. Stephanidis. Berlin: Springer; pp. 58–62.
- Rogers, E.M. (1962). *Diffusion of Innovations*. Glencoe: Free Press.

Roth, K.; Brodrick, J. (2008). “Home Energy Displays.” *ASHRAE Journal* (50:7);136–137.

Southern California Edison (2012). *Future Outlook for Residential Energy Management Research*. Rosemead, CA: Southern California Edison.

Spagnolli, A.; Corradi, N.; Gamberini, L.; Hoggan, E.E.; Jacucci, G.; Katzeff, C.; Broms, L.; Jönsson, L. (2011). “Eco-Feedback on the Go: Motivating Energy Awareness.” *IEEE Computer* (44:5); 38–45.

Tendril (2012). “The Inspiration That Was SXSW 2012.” Accessed March 20, 2012: <http://www.tendrilinc.com/blog/the-inspiration-that-was-sxsw-2012/>.

van Dam, S.S.; Bakker, C.A.; van Hal, J.D.M. (2010). “Home Energy Monitors: Impact over the Medium-Term.” *Building Research & Information* (38:5); 458–469.

Wallenborn, G.; Orsini, M.; Vanhaverbeke, J. (2011). “Household Appropriation of Electricity Monitors.” *International Journal of Consumer Studies* (35); 146–152.

Wilhite, H.; Ling, R. (1995). “Measured Energy Savings from a More Informative Energy Bill.” *Energy and Buildings* (22); pp. 145–155.

## Appendix A: HEM Stimuli Used in Study 1.





Four exemplars were shown to participants for each medium type (HED, Web, and smartphone). This table provides the company and representative display for all 12 exemplars used in Study 1:

Medium	Exemplar			
<i>HED</i>	* Cisco Home Energy Controller	General Electric Brillion Energy Display	Onzo Energy Display	Current Cost Energy Monitor
<i>Web</i>	~ Tendril Vantage Dashboard	eMeter Energy Engage Consumer Portal	eMonitor Dashboard Server	The Energy Detective Footprints Software
<i>Smartphone</i>	* Microsoft Hohm App Concept	* Google Powermeter for smartphone	JouleBug iPhone App	Meter Timer PRO iPhone App



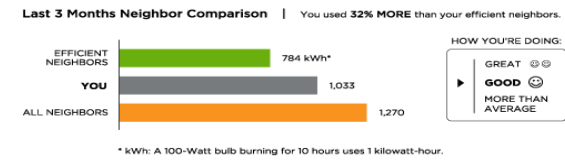

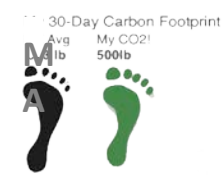
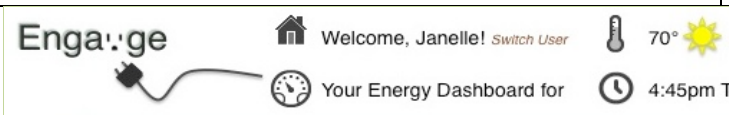
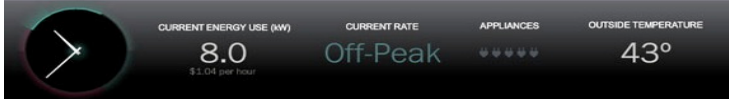
\* Product no longer available / ~ Interface has changed since time of study

## Appendix B: Images Used in Study 2





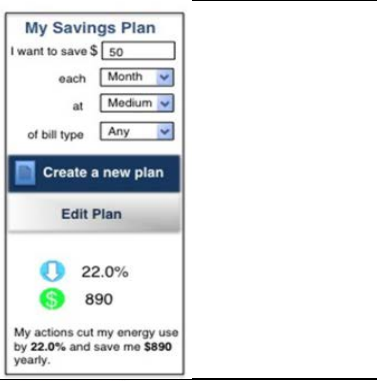

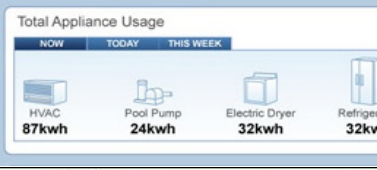
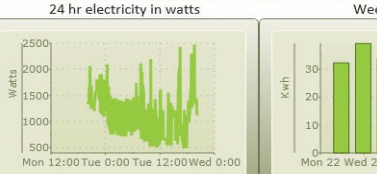
These images show category type, times picked, and engagement rating.

Thumbnail	Category_ Exemplar	Times Picked	Engagement Rating
	Compare_1	8	3.50
	Compare_2	6	3.65
	Compare_3	1	2.50
	Compare_4	1	3.08
	Display_1	1	3.15
	Display_2	12	3.68
	Display_3	0	3.42
	Display_4	0	2.58

Thumbnail	Category_ Exemplar	Times Picked	Engagement Rating																
 <p>Usage Alerts</p> <p><input type="checkbox"/> Notify me weekly of changes in my energy use An easy way to keep track of trends.</p> <p><input type="checkbox"/> Notify me when a particular circuit is drawing little or no power for an extended period Select this alert, for example, to check on medical equipment or computers you would like to keep on, or to make sure your furnace is running.</p> <p><input type="checkbox"/> Notify me when one of the selected appliances uses at least <input type="text" value="15"/> % more energy than it did before This may be an indication of a problem.</p> <p><input type="checkbox"/> Notify me when my use per load for the selected appliances has increased by at least <input type="text" value="15"/> % Find out when your dishwasher, washer, or dryer is using more energy per load than before.</p>	Display_5	9	3.04																
 <p>Phoenix, AZ</p> <p> <b>48°</b></p> <p>73° 48° Partly Cloudy Humidity: 24% Wind: 5 km/h</p>	Extra_1	2	3.73																
 <p>Temperature</p> <p>Indoor <b>74°</b>  </p> <p>Outdoor <b>76°</b>  Sunny</p>	Extra_2	3	4.19																
 <p>Thermostat Living Room</p> <p>Hold Until: January 9, 2011</p> <p><b>68°</b> <input type="text" value="70"/> Cool <input type="text" value="60"/> Heat m: auto f: auto</p>	Extra_3	8	3.73																
 <p>55° 65° <b>76°</b> 85° 95°</p> <p>72° Current Cool Fan Auto</p> <p>82     </p>	Extra_4	4	3.35																
 <p>Current Thermostat Settings (Thursday, April 21, 2011, 12:42 PM)</p> <p> Mode: <input checked="" type="radio"/> Heating <input type="radio"/> Cooling <input type="radio"/> Off Fan: <input checked="" type="radio"/> Auto <input type="radio"/> On Workday Away Setting: 62°F <input type="button" value="Hold"/></p> <p>Outdoor Temp: 52°F</p>	Extra_5	3	3.42																
 <p>80°  5 mph  32%</p>	Extra_6	2	2.73																
 <p>Goal Progress This Week   Billing Period   Year to Date</p> <p>Your Goal This Billing Period: <b>\$97</b></p> <p>Estimated Cost To Date  \$52 of \$97</p> <p>Projected Cost This Period  \$102 of \$97</p> <p> You need to save \$5 in the next 4 days to make your goal this week. <a href="#">Edit your 15% goal</a>   <a href="#">How is this calculated?</a></p>	Goals_1	5	3.81																
 <p>This Week's Cost</p> <p></p> <table border="1"> <thead> <tr> <th>Day</th> <th>Cost</th> </tr> </thead> <tbody> <tr> <td>SUN JUN 18</td> <td>\$4.24</td> </tr> <tr> <td>MON JUN 19</td> <td>\$5.01</td> </tr> <tr> <td>TUE JUN 20</td> <td>\$4.76</td> </tr> <tr> <td>WED JUN 21</td> <td>\$5.66</td> </tr> <tr> <td>FRI JUN 23</td> <td>\$5.12</td> </tr> <tr> <td>THU JUN 22</td> <td>\$3.12</td> </tr> <tr> <td>SAT JUN 24</td> <td>\$2.19</td> </tr> </tbody> </table>	Day	Cost	SUN JUN 18	\$4.24	MON JUN 19	\$5.01	TUE JUN 20	\$4.76	WED JUN 21	\$5.66	FRI JUN 23	\$5.12	THU JUN 22	\$3.12	SAT JUN 24	\$2.19	Goals_2	4	3.38
Day	Cost																		
SUN JUN 18	\$4.24																		
MON JUN 19	\$5.01																		
TUE JUN 20	\$4.76																		
WED JUN 21	\$5.66																		
FRI JUN 23	\$5.12																		
THU JUN 22	\$3.12																		
SAT JUN 24	\$2.19																		



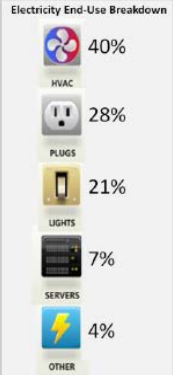

Thumbnail	Category_ Exemplar	Times Picked	Engagement Rating
	Goals_3	9	4.50
	Goals_4	2	3.50
	Goals_5	2	3.38
	Goals_6	4	3.73
	History_1	2	3.38
	History_2	0	3.15



Thumbnail	Category_ Exemplar	Times Picked	Engagement Rating												
 <p>Day <a href="#">Daily Totals</a> <a href="#">Week</a> <a href="#">more</a></p> <p>power in W</p> <p>Monday 8.2 kWh used Tuesday 2.7 kWh used Nice! (63%)</p> <p>About even with expected usage so far today</p> <p>used: night   morning   2.7 kWh exp.: night   morning   all   evening   9.5 kWh</p>	History_3	4	2.92												
 <p>Energy Usage</p> <p>Usage is up <b>32%</b></p> <p>This billing period so far compared to last billing period at this time.</p>	History_4	3	3.84												
 <p>By day   By week   By month   By year</p> <p>watts</p>	History_5	4	3.04												
 <p>My Energy Report Card</p> <table border="1"> <thead> <tr> <th></th> <th>This Month</th> <th>Previous 8 Months</th> </tr> </thead> <tbody> <tr> <td>Average Daily Cost</td> <td>\$2.33</td> <td>\$2.82</td> </tr> <tr> <td>Average Daily kWh</td> <td>16.3 kWh</td> <td>19.8 kWh</td> </tr> <tr> <td>Average Daily CO2</td> <td>15.2 lbs</td> <td>18.3 lbs</td> </tr> </tbody> </table>		This Month	Previous 8 Months	Average Daily Cost	\$2.33	\$2.82	Average Daily kWh	16.3 kWh	19.8 kWh	Average Daily CO2	15.2 lbs	18.3 lbs	History_6	3	3.54
	This Month	Previous 8 Months													
Average Daily Cost	\$2.33	\$2.82													
Average Daily kWh	16.3 kWh	19.8 kWh													
Average Daily CO2	15.2 lbs	18.3 lbs													
 <p>Electricity End-Use Breakdown</p> <ul style="list-style-type: none"> <li>HVAC 40%</li> <li>PLUGS 28%</li> <li>LIGHTS 21%</li> <li>SERVERS 7%</li> <li>OTHER 4%</li> </ul>	History_7	6	3.50												
 <p>Top 5 Appliances/Circuits On Now</p> <ul style="list-style-type: none"> <li>Kitchen Fridge (155w)</li> <li>Office (122w)</li> <li>Furnace (104w)</li> <li>Basement Refrigerator (103w)</li> <li>Study (50w)</li> </ul>	History_8	4	3.57												

Thumbnail	Category_ Exemplar	Times Picked	Engagement Rating
	History_9	8	3.92
	Real-time_1	11	3.73
	Real-time_2	3	3.65
	Real-time_3	0	3.42
	Real-time_4	3	3.38
	Real-time_5	3	3.54
	Real-time_6	3	3.12

Thumbnail	Category_ Exemplar	Times Picked	Engagement Rating
	Real-time_7	1	3.27
<p>Real-Time Use</p> <p><b>\$0.48</b> per Hour</p> <p><b>3.940</b> kilowatts</p> <p>January 12 1:18PM</p>	Real-time_8	0	3.12
	Social_1	6	3.85
	Social_2	4	3.12
	Social_3	8	3.58
	Social_4	0	3.50
	Tips_1	4	3.77

Thumbnail	Category_ Exemplar	Times Picked	Engagement Rating
<p><b>Be Energy Efficient</b>      <b>Reduce Your Impact</b></p> <div style="display: flex; justify-content: space-between;"> <div style="width: 45%;">  <p><b>Consumption At A Glance</b> Though accounting for only 5 percent of the world's population, Americans consume 26 percent of the world's energy. <a href="#">More Usage Tips</a></p> </div> <div style="width: 45%;">  <p><b>Renewable Energy</b> Within 15 years, renewable energy could be generating enough electricity to power 40 million homes and offset 70 days of oil imports. <a href="#">More Green Tips</a></p> </div> </div>	Tips_2	1	2.92
<div style="background-color: #0056b3; color: white; padding: 10px;"> <h2 style="margin: 0;">Electricity</h2> <p><b>Measured in Kilowatts per hour</b> The kilowatt (symbol: kW), is equal to one thousand watts.</p> <p><b>Did you know?</b> Most electronic devices continue to draw electricity even when turned off or left in "standby" mode. In fact, according to ENERGY STAR, the amount of electricity used nationally by idle equipment is roughly equal to the output of 17 power plants. <a href="#">learn more</a></p> </div>	Tips_3	3	3.04
 <p><a href="#">Learn More</a></p> <p>Before you leave your home, change your thermostat setting by dropping it 8-10 degrees.</p>  <p><b>I Did It!</b></p>	Tips_4	7	3.42

*buildingamerica.gov*

U.S. DEPARTMENT OF  
**ENERGY** | Energy Efficiency &  
Renewable Energy

DOE/GO-102012-3805 • December 2012

Printed with a renewable-source ink on paper containing at least 50% wastepaper, including 10% post-consumer waste.