

**GA-A24488**

**CONDITIONING AND PROTECTION CIRCUITRY FOR  
EXTERNAL MODULATION OF A PREPROGRAMMED  
GYROTRON CATHODE VOLTAGE COMMAND WAVEFORM**

**by  
D. PONCE, J.R. FERRON, and R.A. LEGG**

**MARCH 2004**

## DISCLAIMER

This report was prepared as an account of work sponsored by an agency of the United States Government. Neither the United States Government nor any agency thereof, nor any of their employees, makes any warranty, express or implied, or assumes any legal liability or responsibility for the accuracy, completeness, or usefulness of any information, apparatus, product, or process disclosed, or represents that its use would not infringe privately owned rights. Reference herein to any specific commercial product, process, or service by trade name, trademark, manufacturer, or otherwise, does not necessarily constitute or imply its endorsement, recommendation, or favoring by the United States Government or any agency thereof. The views and opinions of authors expressed herein do not necessarily state or reflect those of the United States Government or any agency thereof.

GA-A24488

**CONDITIONING AND PROTECTION CIRCUITRY FOR  
EXTERNAL MODULATION OF A PREPROGRAMMED  
GYROTRON CATHODE VOLTAGE COMMAND WAVEFORM**

by

**D. PONCE, J.R. FERRON, and R.A. LEGG\***

**\*Synchrotron Radiation Center**

This is a preprint of a paper presented at the 20th IEEE/NPSS Symposium on Fusion Engineering, San Diego, California, October 14-17, 2003 and to be published in *Fusion Science and Technology*.

**Work supported by  
the U.S. Department of Energy  
under Contract No. DE-AC03-99ER54463**

**GENERAL ATOMICS PROJECT 30033  
MARCH 2004**

# Conditioning and Protection Circuitry for External Modulation of a Preprogrammed Gyrotron Cathode Voltage Command Waveform

Dan Ponce, J.R. Ferron, and R.A. Legg<sup>a</sup>

General Atomics, PO Box 85608, San Diego, CA 92186-5608

<sup>a</sup>Synchrotron Radiation Center, 3731 Schneider Dr., Stoughton, WI 53589-3097

**Abstract.** The modulating voltages applied to the DIII-D gyrotrons are controlled by reference signals which are synthesized by arbitrary waveform generators. These generators allow ECH operators to pre-program reference waveforms consisting of ramps, flat tops, and various modulation shapes. This capability is independent of the DIII-D central timing and waveform facilities, which provides the ECH operators operational flexibility. The waveform generators include an amplitude modulation input, providing a means to control the pre-programmed waveform externally. This input is being used to allow the DIII-D plasma control system (PCS) to control gyrotron power in response to selected feedback signals. As the PCS control signal could potentially modulate the gyrotrons beyond operational limits or otherwise in a manner leading to recalcitrant rf generation, the control signal is conditioned so that its effect upon the ECH pre-programmed reference waveform is limited by conditions set by the ECH operators. The design of the circuitry which restricts the range over which the PCS control signal may modulate the reference waveform will be discussed. Test and DIII-D experimental results demonstrating the utility and effectiveness of gyrotron power modulated by the PCS will be presented.

## I. INTRODUCTION

There are five gyrotrons available at the DIII-D National Fusion Facility for electron cyclotron heating (ECH) and current drive (ECCD). Together, they inject an average power of 3.5 MW. They participated in the successful demonstration of plasma science experiments such as neo-classical tearing mode (NTM) suppression and current profile control [1].

DIII-D uses a real-time computer control system, designated the plasma control system (PCS), to control and respond to plasma parameters and events within the tokamak [2]. Allowing this system to control injected gyrotron power expands the range of parameters which can be controlled and hence the breadth of experiments which can be conducted.

Philosophically, it is desirable to maintain responsibility for establishing gyrotron operating parameters with the gyrotron control system (GCS) [3]. This is in lieu of relying on the PCS for gyrotron operation and unnecessarily burdening the PCS. To accomplish this, the PCS provides a real-time dimensionless input to the GCS, which is interpreted as a throttle signal. The GCS is responsible for conditioning this throttle signal into a modulation input to be used by the gyrotron cathode reference waveform generator.

## II. CIRCUIT DESIGN REQUIREMENTS

Circuit design requirements were established with the goal of ECH retaining responsibility for controlling the operating regime of the gyrotrons and for the PCS to modulate

output rf power within that regime. A method for accomplishing this was conveniently provided by the arbitrary waveform generator already used to form the reference signal for the gyrotron cathode voltage. The Wavetek model 395 includes an AM input which modulates its output. This feature could be used by the PCS to modulate a baseline reference waveform preprogrammed by the GCS. The PCS signal would have to be limited to avoid over-modulating the waveform. Overly enhancing the waveform could cause the gyrotrons to exceed their design parameters. Overly depressing the waveform could cause the gyrotrons to change mode, leading to recalcitrant rf generation. It could also cause excessive charging currents if the waveform was subsequently raised too quickly. The charging currents might be interpreted as fault currents by the protective circuitry and lead to pulse termination. To avoid these scenarios and remain in a desirable operating regime, the AM input to the waveform generator would be formed by weighing the PCS signal, the predetermined gyrotron cathode voltage operating range, and the peculiarities of how the AM input signal is used by the waveform generator.

In practice, the GCS shall program the reference waveform for maximum available gyrotron performance, under the discretion of the ECH operators. Thus, the AM input will be used only to reduce, and not enhance, gyrotron output power. Importantly, the GCS waveform also establishes the baseline pulse initiation ramps, which encourage development of the desired RF mode without excessive charging currents.

The GCS will interpret the PCS signal as a throttle input. A maximal signal will allow the preprogrammed GCS waveform to pass unaltered, resulting in maximum available power. A minimal PCS signal will result in passing a reference level previously determined to result in minimal rf generation without driving the gyrotron into an unrecoverable operating regime.

## III. CIRCUIT DESIGN

The circuit which conditions the input from the PCS is built around the Analog Devices AD633 4-quadrant analog multiplier IC. It includes two differential scaling inputs and a summing input (Fig. 1).

The Wavetek 395 uses a 2.5 Vpp signal fed to its AM input to modulate a pre-programmed waveform. A voltage of 1.25 V corresponds to 100% scaling and -1.25 V results in 0% scaling. The desired signal to the AM input can be determined by assuming that (1) it is desired to keep the reference signal output by the Wavetek between predefined HiLimit and LoLimit values; (2) that the preprogrammed signal is

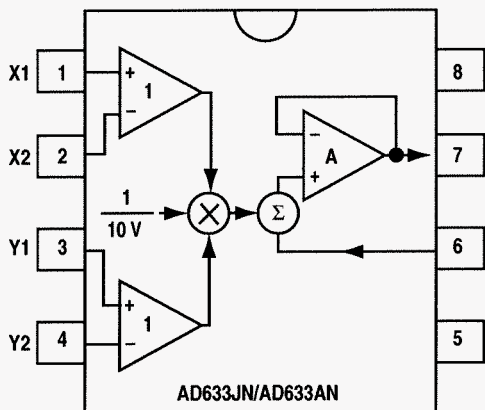

Fig. 1. AD633 analog multiplier IC pin-out. © Analog Devices, Inc.

nominally at the level of HiLimit; and (3) that the PCS throttle signal,  $V_{pcs}$ , ranges from 0 to 10 V. Assumptions 1 and 2 apply to the portion of the reference signal following the pulse initiation ramps. In practice, this portion of the reference signal will be at a constant level if PCS modulation is to be applied. The desired signal to the AM input is then given by

$$\frac{2.5}{HiLimit} \left[ \frac{V_{pcs}}{10} (HiLimit - LoLimit) + LoLimit \right] - 1.25 \quad (1)$$

Reformulated so the operands map to the inputs of the AD633, this equation becomes

$$\left[ \left( 10 - \frac{10LoLimit}{HiLimit} \right) \frac{V_{pcs}}{10} + \frac{10LoLimit}{HiLimit} \right] \frac{1}{4} - 1.25 \quad (2)$$

The factor of 1/4 and the offset of 1.25 are applied to the output of the AD633.

A biased, bipolar diode limiter sub-circuit (Fig. 2) restricts the incoming PCS signal to a 0 V to +10 V range. An analog output channel of a programmable logic controller (PLC) supplies the 10VLoLimit/HiLimit reference level.

The data sheets for the AD633 claim an accuracy of 2% of full scale and a non-linearity of up to 0.4% of full scale. With a scaling factor of  $10 \text{ V} = 100 \text{ kV}$ , 2% accuracy equates to 2 kV. The 10 V bandwidth is 1 MHz, the slew rate is  $20 \text{ V}/\mu\text{s}$ , and noise is less than  $100 \mu\text{V}$ . These specifications are adequate for the application.

#### IV. CIRCUIT TESTING

The circuit for each gyrotron was tested to verify the protection and performance aspects of the design prior to first use with high voltage. The diode limiter sub-circuit was closely examined along with the rest of the circuit to ensure that the PCS signal could not drive the cathode voltage reference waveform beyond the desired operating range. The circuits were also checked for linearity and accuracy within the operating range.

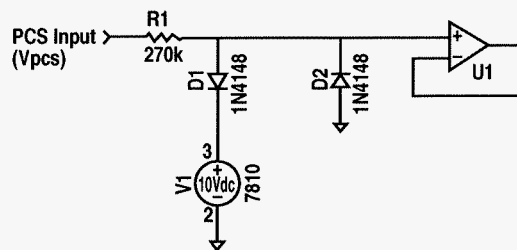

Fig. 2. Diode limiter sub-circuit restricts range of input PCS signal.

Full system tests including the PCS were performed using DIII-D plasmas as targets. These tests demonstrated that gyrotron output power would follow complex PCS command signals with sufficient fidelity. Fig. 3 illustrates one of the test signals and the resultant gyrotron rf output. The PCS commands nine periods of 50 Hz square wave modulation followed by a 300 ms ramp-down. The pre-programmed GCS waveform (not shown) ramps up for about 30 ms and then remains flat for the remainder of the 500 ms pulse. The rf output follows the product of these two waveforms. The irregularity seen in the rf output is partially due to non-fundamental components present at the waveguide power monitor used, which is located close to the gyrotron.

#### V. EXPERIMENTAL USAGE

The usefulness of this capability is realized when the PCS is used in feedback mode to control plasma parameters. An example of this is using the PCS to control the electron temperature ( $T_e$ ) profile with ECH [4]. Fig. 4 illustrates a test using a saw-tooth waveform as the target for  $T_e$ . Tracking is quite good when gyrotron power is required to increase the electron temperature.  $T_e$  is lowered passively, where the PCS control signal is minimized. Interestingly, gyrotron power is insufficient to reach the target on the last peak, and the PCS control signal reaches a plateau as would be expected. Ref. [4] provides additional examples of  $T_e$  profile control.

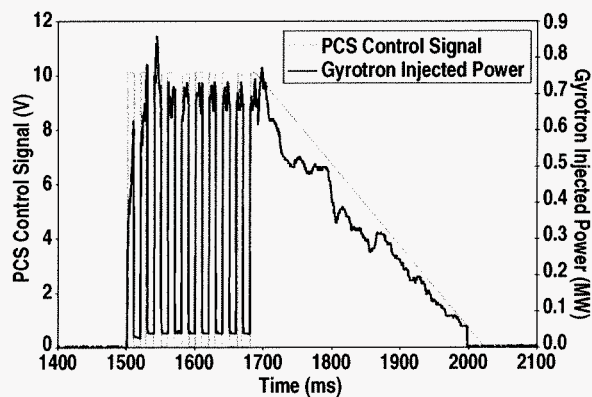

Fig. 3. Gyrotron output power sufficiently follows complex PCS control signals.

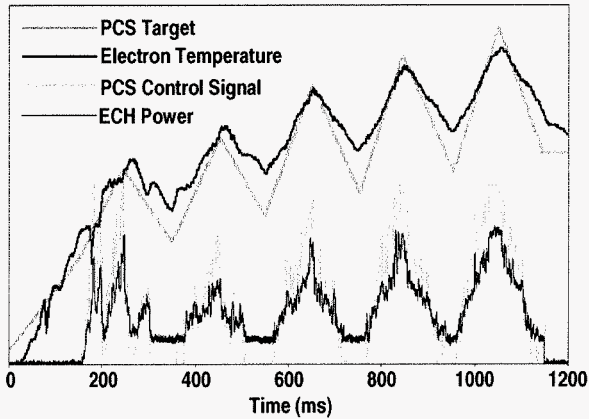

Fig. 4. Arbitrary control of the plasma electron temperature using PCS control with feedback. Since gyrotron power can raise but not lower the electron temperature, fidelity is best near the target peaks. On the last cycle, gyrotron power is insufficient to reach the target, as evidenced by the plateau on the PCS control signal.

#### CONCLUSIONS

The conditioning and protection circuitry presented allows the DIII-D Plasma Control System to regulate gyrotron output power without burdening the PCS with maintaining gyrotron operation. Responsibility for controlling the operating regime of the gyrotrons remains with the gyrotron control system and its operators. Gyrotron output power follows the PCS control signal with sufficient fidelity to be useful for plasma experiments. When used with feedback control, the PCS and

ECH can control plasma parameters such as the electron temperature profile.

#### ACKNOWLEDGMENT

Work supported by Department of Energy Contract No. DE-AC03-99ER54463.

#### REFERENCES

- [1] R. Callis, et. al., "Maturing ECRF technology for plasma control," *Proc. of the 19th IAEA Fusion Energy Conference*, Lyon, France, (International Atomic Energy Agency, Vienna), 2002.
- [2] D. Piglowski, B. Penaflor, and J. Ferron, "Interprocess communication within the DIII-D Plasma Control System," *Proc. of the 11th IEEE/NPSS Real Time Conference*, Santa Fe, New Mexico, (Institute of Electrical and Electronics Engineers, Inc., Piscataway, New Jersey), 1999.
- [3] D. Ponce, H. Chiu, M. Condon, I. Gorelov, R. Legg, and F. W. Baity, Jr., "The DIII-D multiple gyrotron control system," *Proc. of the 19th IEEE/NPSS Symposium on Fusion Engineering*, Atlantic City, New Jersey, (Institute of Electrical and Electronics Engineers, Inc., Piscataway, New Jersey), 2002, pp. 184-187.
- [4] J. Lohr, J. Ferron, Y. Gorelov, K. Kajiwara, D. Ponce, and M. Wade, "Feedback control of the DIII-D ECH system," *Proc. of the 27th International Conference on Infrared and Millimeter Waves*, San Diego, California, 2002, submitted for publication.