

**OFFICE OF CIVILIAN RADIOACTIVE WASTE MANAGEMENT
CALCULATION COVER SHEET**

1. QA: QA

Page: 1 Of: 50

2. Calculation Title
TRIGA Fuel Phase I and II Criticality Calculation

MOL.19991209.0195

3. Document Identifier (including Revision Number)
CAI-MGR-NU-000001 REV 00

4. Total Attachments
5

5. Attachment Numbers - Number of pages in each
I-4, II-4, III-1, IV-2, V-7
III-1 LA 11/22/99

	Print Name	Signature	Date
6. Originator	Laetitia Angers	<i>Laetitia Angers</i>	11/22/99
7. Checker	Leland Montierth	<i>for John W. Davis</i>	11/23/99
8. Lead	J. Wesley Davis	<i>John W. Davis</i>	11/23/99

9. Remarks
Attachment V is the Document Input Reference Sheet

Revision History

10. Revision No.	11. Description of Revision
00	Initial Issue

CONTENTS

	Page
1. PURPOSE.....	7
2. METHOD.....	7
3. ASSUMPTIONS.....	8
4. USE OF COMPUTER SOFTWARE AND MODELS.....	10
4.1 SOFTWARE APPROVED FOR QUALITY ASSURANCE (QA) WORK.....	10
4.1.1 MCNP.....	10
4.2 SOFTWARE ROUTINES.....	10
4.2.1 Excel.....	10
4.3 MODELS.....	10
5. CALCULATION.....	11
5.1 INTACT WP.....	12
5.1.1 Codisposal Waste Package.....	12
5.1.2 SRS HLW Glass Pour Canister.....	13
5.1.3 DOE SNF Canister.....	13
5.1.4 DOE TRIGA Fuel.....	15
5.1.4.1 Stainless Steel-Clad TRIGA Rods.....	16
5.1.5 Materials Compositions.....	20
5.1.6 Intact Cases.....	25
5.2 DEGRADED CASES.....	26
5.2.1 Waste Form Degrades Before the Other Internal Components.....	27
5.2.1.1 WF Degrades but the DOE SNF Canister and the Basket are Intact..	27
5.2.1.2 WF and Basket Degrade but the DOE SNF Canister, SRS HLW Glass, SRS HLW Glass Pour Canister, and Web-Like Structure are Intact..	29
5.2.1.3 All WP Components Degrade.....	31
5.2.2 Waste Form Degrades After the Other Internal Components.....	31
5.2.2.1 DOE SNF Canister Intact.....	32
5.2.2.2 Waste Form Intact, Other Internal Component Degraded.....	33
5.2.3 Intermediate Degraded Configuration.....	34
6. RESULTS.....	36
6.1 INTACT CASES.....	36
6.2 DOE SNF CANISTER DEGRADED.....	38
6.2.1 Waste Form Degrades Before the Other Internal Components.....	38
6.2.1.1 WF Degrades but the DOE SNF Canister and the Basket are Intact..	38
6.2.1.2 WF and Basket Degrades but the DOE SNF Canister, SRS HLW Glass, SRS HLW Glass Pour Canister, and Web-Like Structure are Intact.....	41
6.2.1.3 All WP Components Degrade.....	43

6.2.2 Waste Form Degrades After the Other Internal Components..... 44
 6.2.2.1 DOE SNF Canister Intact..... 44
 6.2.2.2 Waste Form Intact, Other Internal Components Degraded..... 47
6.2.3 Intermediate Degraded Configuration..... 49
7. ATTACHMENTS..... 50

FIGURES

	Page
5-1. Cross Section of the Intact Codisposal WP.....	12
5-2. DOE SNF Canister Section View.....	14
5-3. Cross-Sectional View of the DOE SNF Canister with Basket.....	15
5-4. Sketch of Stainless Steel-Clad TRIGA Rods, TRIGA-SS.....	17
5-5. Cross-Sectional Sketch of a TRIGA-SS Rod.....	18
5-6. WP and DOE SNF Canister Dimensions (in cm) Used in this Calculation.....	24
5-7. Longitudinal Cross Section of the DOE SNF Canister.....	26
5-8. Cross Section of DOE SNF Canister (basket intact, clad degraded).....	27
5-9. Cross Section of DOE SNF Canister (fuel partially fractured).....	28
5-10. Cross Section of DOE SNF Canister (SS tubes degraded).....	30
5-11. Cross Section of DOE SNF Canister (advanced absorber matrix accumulated among the rods).....	30
5-12. Cross Section of the DOE SNF Canister (the fuel degrades).....	31
5-13. Cross Section of a Degraded WP.....	32
5-14. Cross Section of the WP with the WF Intact at the Bottom.....	33
5-15. Cross Section of the WP with the WF Degraded at the Bottom.....	34
5-16. Cross Section of the WP in an Intermediate Degradation Stage.....	35
6-1. Emplacement of the Advanced Absorber Matrix Coat.....	37
6-2. Cross Section of the DOE SNF Canister with the Emplacement of 45 Advanced Absorber Matrix Coated Tubes.....	39

TABLES

	Page
5-1. Stainless Steel-Clad TRIGA Rods Components and Materials.....	18
5-2. Stainless Steel-Clad Fuel Elements Initial Loadings.....	19
5-3. Composition of SS 304L	20
5-4. Composition of Alloy 22 (UNS N06022).....	20
5-5. SRS HLW Glass Chemical Composition	21
5-6. Composition of A 516 Carbon Steel Grade 70.....	21
5-7. Composition of Fuel Types FLIP and FLIP-LEU-I	22
5-8. Composition of Stainless Steel 316L.....	22
5-9. Composition of the Advanced Absorber Matrix (Alloy 22 with 8 atom % of Gd).....	22
5-10. Composition of Stainless Steel 304.....	23
6-1. Results for the Intact Configuration with Different Fuel Types	36
6-2. Results for the Configuration with the Basket of the DOE SNF Canister Intact, the Fuel Rod Clad Degraded.....	38
6-3. Results for the Configuration with the Fuel Partially Fractured	40
6-4. Results for the Configurations where the U Separates from the ZrH _x	40
6-5. Results for the Configuration with Fuel Element Fully Degraded.....	40
6-6. Results for the Configuration with the Basket Fully Degraded.....	41
6-7. Results for the Configuration with the Fuel Partially Fractured	42
6-8. Results for the Configuration with the Fuel Element and the Basket Fully Degraded	43
6-9. Results for the Configuration with All the Internal Components of the WP Degraded.....	43
6-10. Results for the Configuration with Clad, SRS HLW Glass, SRS HLW Glass Pour Canister, and Web-like Structure Degraded	44
6-11. Results for the Configuration with Clad, Basket, SRS HLW Glass, SRS HLW Glass Pour Canister, and Web-like Structure Degraded.....	45
6-12. Results for the Configuration where All the Internal Components are Degraded Excluding the DOE SNF Canister	46

6-13. Results for the Configuration with the WF Intact and the OIC of the WP Degraded 47

6-14. Results for the Configuration where Some Portion of the Fuel Rods is Degraded while the
SRS HLW Glass is Intact..... 49

7-1. List of Attachments 50

1. PURPOSE

The purpose of this calculation is to characterize the criticality aspect of the codisposal of TRIGA (Training, Research, Isotopes, General Atomic) reactor spent nuclear fuel (SNF) with Savannah River Site (SRS) high-level waste (HLW). The TRIGA SNF is loaded into a Department of Energy (DOE) standardized SNF canister which is centrally positioned inside a five-canister defense SRS HLW waste package (WP).

The objective of the calculation is to investigate the criticality issues for the WP containing the five SRS HLW and DOE SNF canisters in various stages of degradation.

This calculation will support the analysis that will be performed to demonstrate the viability of the codisposal concept for the Monitored Geologic Repository (MGR).

2. METHOD

The calculational method used to perform the criticality calculations consisted of using the MCNP Version 4B2 code (Briesmeister 1997) to calculate the effective neutron multiplication factor (k_{eff}) of the codisposal WP. The calculation was performed using the continuous-energy cross-section libraries from the Evaluated Nuclear Data Files (ENDF). All calculations were performed with fresh fuel (Assumption 3.3).

3. ASSUMPTIONS

- 3.1 For degraded mode criticality calculations, the iron in the stainless steel degrades to goethite (FeOOH) and/or to hematite (Fe_2O_3). In this calculation, goethite is assumed to be the final degradation product. The basis of this assumption is that it is conservative to consider goethite rather than hematite since hydrogen (moderator) is a component of goethite. All the other constituents of the steel are neglected.

One cm^3 of iron expands into 2.9 cm^3 of goethite after degradation (Attachment III, "05-24-99.xls", set1). However, in this calculation, the volume of goethite is assumed to be equal to the volume of iron, thus some iron is neglected. The basis of this assumption is that it is conservative to neglect iron since it provides only a small amount of neutron absorption. This assumption is used throughout Section 5.

- 3.2 It is assumed that there is no erbium in the waste package, i.e., no credit is taken for the erbium. The basis of this assumption is that it is conservative to neglect the erbium since it is a neutron absorber, and hence its absence provides a conservative (higher) value for the k_{eff} of the system. This assumption is used throughout Section 5.
- 3.3 No credit is taken for the fuel burnup, i.e., fuel is assumed to be fresh (non-irradiated). The basis of this assumption is that it is conservative because fresh fuel is more neutronically reactive than spent fuel. This assumption is used throughout Section 5.
- 3.4 The neutron absorber (referred to as advanced absorber matrix in this calculation) is assumed to be made of Alloy 22 with 8 atom % of gadolinium. The basis of this assumption is that this material is currently being developed at Idaho National Engineering and Environmental Laboratory (INEEL) and material property data are unavailable. The composition of this material is given in Attachment III, Excel file named "gd compo.xls". This assumption is conservative, as the components of Alloy 22 have low thermal neutron absorption cross sections. This assumption is used throughout Section 5.
- 3.5 The skirt at each end of the codisposal waste package is neglected. The basis of this assumption is that it is conservative since the skirt is made of stainless steel and that the stainless steel components are neutron absorbers. This assumption is used throughout Section 5.

- 3.6 Ba-138 cross section is used instead of Ba-137 cross section in the MCNP input since the cross section of Ba-137 is not available in either ENDF/B-V or ENDF/B-VI cross-section libraries. The basis of this assumption is that it is conservative since the thermal neutron capture cross section and the resonance integral of Ba-137 (5.1 and 4 barn, respectively, Parrington et al. 1996, p. 34) are greater than the thermal neutron capture cross section and the resonance integral of Ba-138 (0.43 and 0.3 barn, respectively, Parrington et al. 1996, p. 34). This assumption is used throughout Section 5.
- 3.7 The density of the graphite was assumed to be the same as that of graphite grade A (Lynch 1975, p. 367). The basis of this assumption is that it is conservative as shown in Table 6-6 (case set49b.O). This assumption is used throughout Section 5.
- 3.8 Aluminum cross section is used instead of zinc cross section in the MCNP input since the cross section of zinc is not available in either ENDF/B-V or ENDF/B-VI cross-section libraries. The basis of this assumption is that it is conservative since the thermal neutron capture cross section and the resonance integral of zinc (1.1 and 2.8 barn, respectively, Parrington et al. 1996, p. 26) are greater than the thermal neutron capture cross section and the resonance integral of aluminum (0.23 and 0.17 barn, respectively, Parrington et al. 1996, p. 20). This assumption is used throughout Section 5.
- 3.9 The SRS HLW glass is assumed to occupy 100% of the HLW glass pour canister instead of 85%. The HLW glass pour canister is represented as a cylinder. It has an outer diameter of 610 mm and an inner length of 2980.95 mm. The basis of this assumption is that it is conservative since the volume of glass and thus the volume of fissile material is increased. This assumption is used throughout Section 5.
- 3.10 The DOE SNF basket brackets are not represented in the cases where the DOE SNF canister is intact. The basis of this assumption is that it is conservative since the basket brackets are made of stainless steel and that the stainless steel components are neutron absorbers. This assumption is used throughout Section 5.

4. USE OF COMPUTER SOFTWARE AND MODELS

4.1 SOFTWARE APPROVED FOR QUALITY ASSURANCE (QA) WORK

4.1.1 MCNP

The MCNP (Civilian Radioactive Waste Management System Management and Operating Contractor [CRWMS M&O] 1998) code was used to calculate the k_{eff} of the codisposal waste package. The software specifications are as follow:

- Software name: MCNP
- Software version/revision number: Version 4B2
- Software tracking number: 30033 V4B2LV
- Computer type: Hewlett Packard (HP) 9000 Series Workstations.

The input and output files attributes for the various MCNP calculations are documented in Attachments I and II, respectively (the electronic reference containing these is CRWMS M&O 1999a). The calculation files described in Sections 5 and 6 are such that an independent repetition of the software used may be performed.

The MCNP software used was: (a) appropriate for the k_{eff} calculations performed, (b) used only within the range of validation as documented in CRWMS M&O (1998), (c) obtained from the Software Configuration Manager in accordance with appropriate procedures.

4.2 SOFTWARE ROUTINES

4.2.1 Excel

- Title: Excel
- Version/Revision Number: Microsoft® Excel
- This software is installed on a personal computer running Microsoft Windows 95.

The Excel spreadsheet programs were used to calculate the isotopic composition of the materials in the waste package, as documented in Section 5 of this calculation (Attachment III, spreadsheets "05-24-99.xls", "EQ6 runs.xls", and "Allde_EQ6.xls"). The user-defined formulas, inputs, and results are documented in sufficient detail in Section 5 to allow an independent repetition of computations.

4.3 MODELS

None Used.

5. CALCULATION

This section describes the calculations performed to calculate the k_{eff} of an intact and a degraded WP containing HLW clayey material outside and TRIGA SNF inside a DOE SNF canister. Section 5.1 gives a description of the intact WP. The k_{eff} of different configurations of a degraded WP is investigated in Section 5.2. Section 5.2.1 describes calculations performed assuming intact SRS HLW glass and TRIGA fuel. In Section 5.2.2, the DOE SNF canister remains intact but the SRS HLW glass degrades. The MCNP output files attributes are presented in Attachment II (the electronic reference is CRWMS M&O 1999a). The results of the calculations are presented in Section 6.

The description of the TRIGA fuel is from the TRIGA description document (DOE 1999). All fuel-related information is from this reference unless otherwise noted.

Compositions for structural and other nonfuel-related materials are from CRWMS M&O (1999b). The material compositions obtained from CRWMS M&O (1999b) are considered accepted data. Data in this reference are taken from standard handbooks, and due to the nature of these sources, these data are established facts and are therefore considered accepted.

The SRS HLW glass degraded composition is from CRWMS M&O (1999f) and the SRS HLW glass composition is from Stout and Leider (1991). These data are unqualified.

Avogadro's number is from Parrington et al. (1996). Atomic weights are from Parrington et al. (1996) and from Benedict et al. (1981); these data are established facts and are therefore considered accepted due to the nature of the references cited therein.

This calculation is based in part on unqualified data such as those from DOE (1999). However, the unqualified data are only used to determine the bounding values and items that are important to safety for the fuel group. The fuel group is identified by the National Spent Nuclear Fuel Program (NSNFP) by establishing the limits based on the representative fuel type (TRIGA) for this group (U fuel). Therefore, the input values used to evaluate the codisposal viability of TRIGA SNF do not constitute data that have to be qualified prior to use of any results from this calculation for input into document supporting procurement, fabrication, or construction. They merely establish the bounds for acceptance. Since the input values are not relied upon directly to address radiological safety and waste isolation issues, nor do the design inputs affect a system characteristic that is critical for satisfactory performance, data do not need to be controlled as TBV.

The number of digits in the values cited herein may be the result of a calculation or may reflect the input from another source; consequently, the number of digits should not be interpreted as an indication of accuracy.

5.1 INTACT WP

The dimensions and material compositions of the codisposal WP are provided in the following subsections. A cross section of the WP is shown in Figure 5-1.

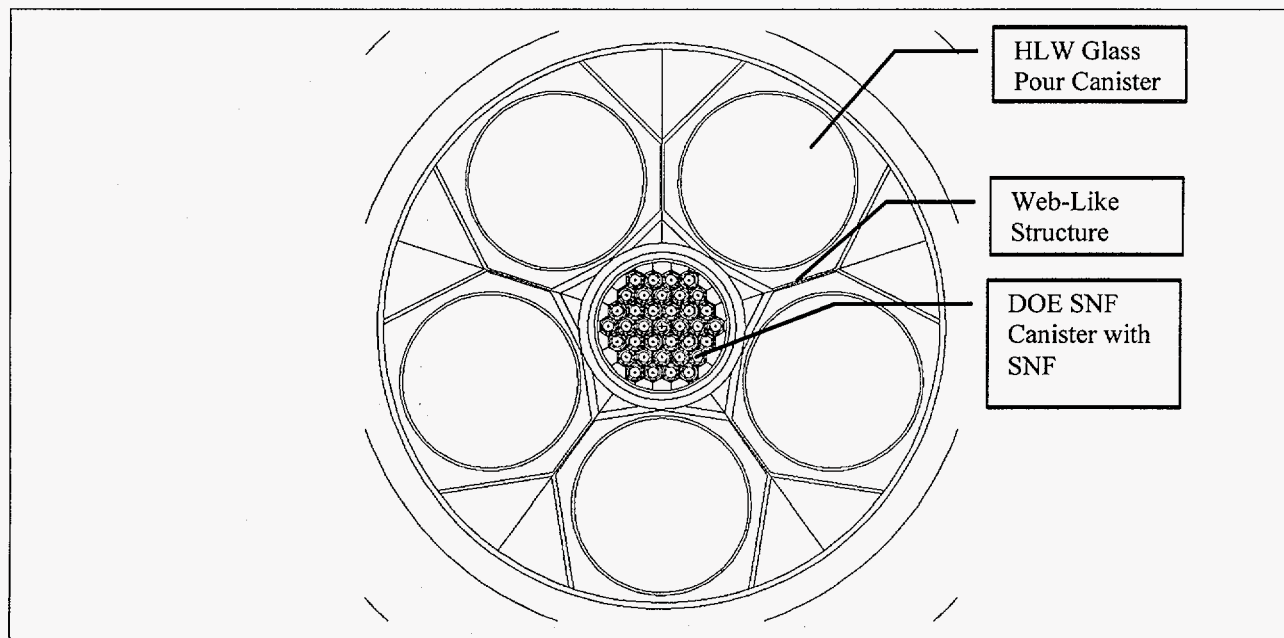

Figure 5-1. Cross Section of the Intact Codisposal WP

5.1.1 Codisposal Waste Package

The codisposal waste package (Attachment IV, p. IV-1) contains five SRS HLW glass canisters surrounding a DOE SNF codisposal canister. The waste package barrier materials are typical of those used for commercial SNF waste containers. The inner barrier shell is composed of 20 mm of Alloy 22 (CRWMS M&O 1999b, p. 30) and serves as a corrosion resistant material. The outer barrier shell is composed of 100 mm of carbon steel (ASTM A 516 Grade 70) and serves as a corrosion allowance material (CRWMS M&O 1997, pp. 56 and 72). The outside diameter of the waste container is 2120 mm and the outer length is 3790 mm. The inner barrier lids are 25 mm thick and the outer barrier lids are 110 mm thick. There is a 30-mm closure lid gap between the upper inner and outer barrier lids. There is a 225-mm long, 60-mm thick skirt at each end of the container.

5.1.2 SRS HLW Glass Pour Canister

The SRS Defense Waste Processing Facility (DWPF) HLW canister is a stainless (Type 304L) steel cylinder shell (Department of Energy [DOE] 1992, pp. 3.3-4 through 3.3-6). It has an outer diameter of 24.00 in. (610 mm is used in this calculation for the outer diameter), a wall thickness of 9.525 mm, and a nominal length of 3000 mm. The flanged head and neck of the canister is 225.6 mm high. The SRS HLW glass occupies 85% of the canister's volume. The glass weight is 1682 kg and the approximate total loaded weight is 2182 kg. The nominal dimensions of the canister are used for the calculations (see Assumption 3.9). The heat generation from a single canister is 690 watts at time of loading based upon maximum activity contents.

5.1.3 DOE SNF Canister

The conceptual design for the DOE one-assembly SNF canister is shown in Figure 5-2 (DOE 1998, Appendix A). It is a right circular cylinder of stainless steel (Type 316L). The canister must be able to stand vertically when placed on a flat surface after being loaded with the SNF. The dimensions for the DOE SNF canister are a 457.2-mm (18.00-in.) outer diameter with a 9.525-mm (0.375-in.) wall thickness. The minimum inner diameter of the canister is 430 mm (16.93 in.). The minimum internal length of the canister is 2547 mm (100 in.) and the nominal overall length is 3000 mm (118.11 in.). The canister maximum total weight is 2270 kg. There is a curved-bottom, carbon steel rupture disk that varies in thickness from 15.24 mm to 50.8 mm at the top and bottom boundaries of the canister. The curved-bottom, carbon steel rupture disk is represented by a 33-mm thick $([50.8+15.24]/2)$ plate.

A basket will be constructed to hold 37 fuel elements, as illustrated in Figure 5-3. Stainless steel tubes will be welded together at the top and bottom with the bottom of the tubes welded to a steel base plate. Three such basket assemblies will be stacked in the SNF container to provide a total of 111 elements per container. Dimensions and materials of the basket are given in Attachment IV, page IV-2.

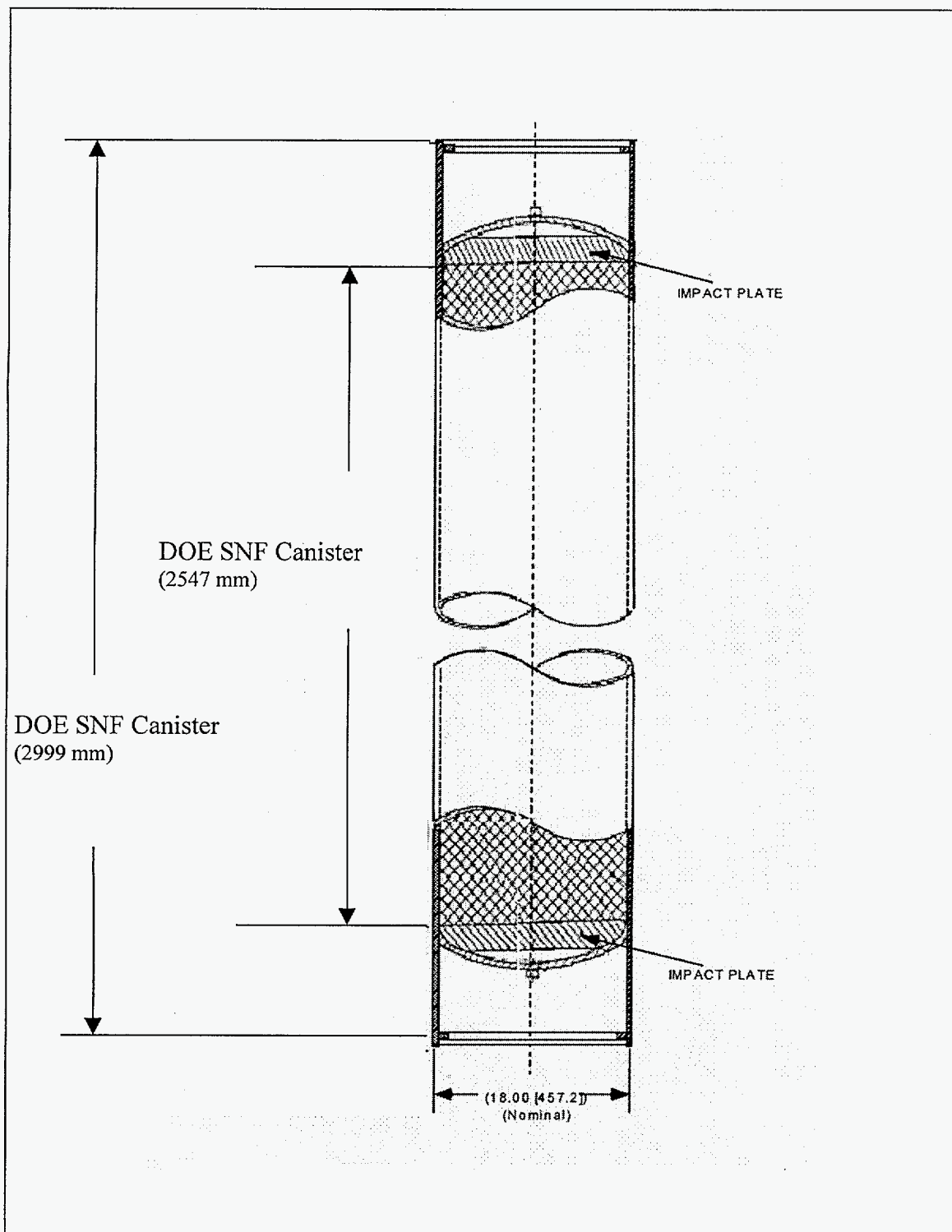

Figure 5-2. DOE SNF Canister Section View

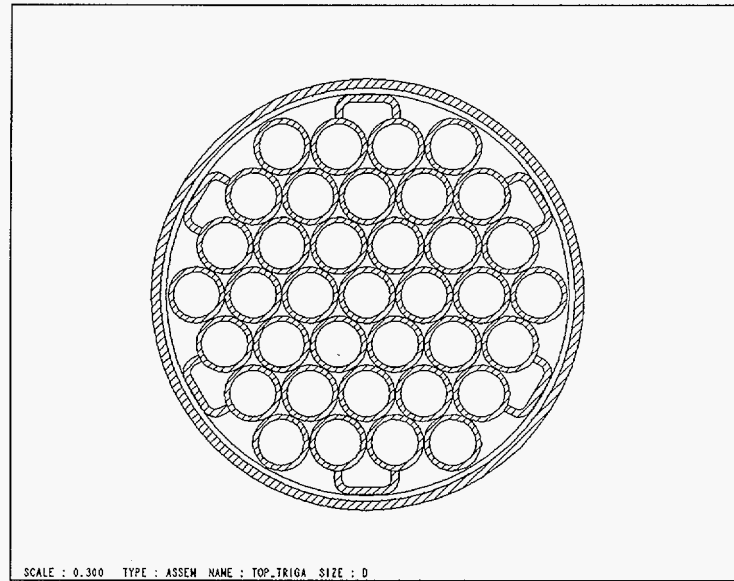

Figure 5-3. Cross-Sectional View of the DOE SNF Canister with Basket

5.1.4 DOE TRIGA Fuel

TRIGA fuel contains various uranium loadings as a fine metallic dispersion in the zirconium hydride matrix. The hydrogen to zirconium (H/Zr) atom ratio is nominally 1.6 (in the face-centered cubic delta phase), although earlier fuels used a H/Zr atom ratio of 1.0. The highly enriched version of TRIGA fuel (discontinued after 1979), as well as new fuels with higher loadings of low enriched uranium, contains up to about 3 weight percent (wt%) erbium as a burnable neutron absorber. This increases the core lifetime and contributes to the prompt negative coefficient in high-power (1 to 14 MW) TRIGA reactors (cores with steady-state power levels above 3 MW are not pulsing cores).

Most of the earlier TRIGA fuels contained a nominal 8.5 wt% uranium. However, TRIGA fuel with up to 12 wt% uranium has also been produced.

The spent TRIGA fuel from Foreign Research Reactors (FRR) will be held in interim storage at the Irradiated Fuel Storage Facility (IFSF) of the INEEL. The inventory of TRIGA fuel falls into four basic categories: aluminum-clad elements, stainless steel-clad elements, Alloy 800 "Incoloy"-clad elements, and fuel follower control rod elements (DOE 1999, p. 9). Each of these basic fuel types has differences in loading, dimensions, and rod components. The TRIGA elements contain fuel rods with a homogeneous mixture of uranium and zirconium-hydride. A fuel composition is identified by an indicator such as U20ZrH1.6. This means that the uranium is 20 wt% enriched U-235 with a H/Zr atom ratio of 1.6. The fuel rods may also contain the burnable neutron absorber erbium. Aluminum-clad TRIGA is referred to as TRIGA-AL, stainless steel-clad TRIGA as TRIGA-SS, and Incoloy-clad TRIGA as TRIGA-IN. The FRR

TRIGA elements include all of these various TRIGA clad fuel rods. In this calculation, only TRIGA-SS is studied.

5.1.4.1 Stainless Steel-Clad TRIGA Rods

There are four types of TRIGA-SS rods; namely, standard streamline type, standard plain type, four-rod cluster type, and Annular Core Pulsed Reactor (ACPR) type. These are illustrated in Figure 5-4 (DOE 1999, p. 13). All TRIGA-SS rods have a 38.1 cm (15.0 in.) length and are clad with 0.0508-cm (0.02-in.) thick stainless steel, see Figure 5-5 for a cross-sectional sketch. A 0.5715-cm (0.225-in.) diameter zirconium rod is placed in a 0.635-cm (0.25-in.) diameter hole drilled through the center of the fuel rods.

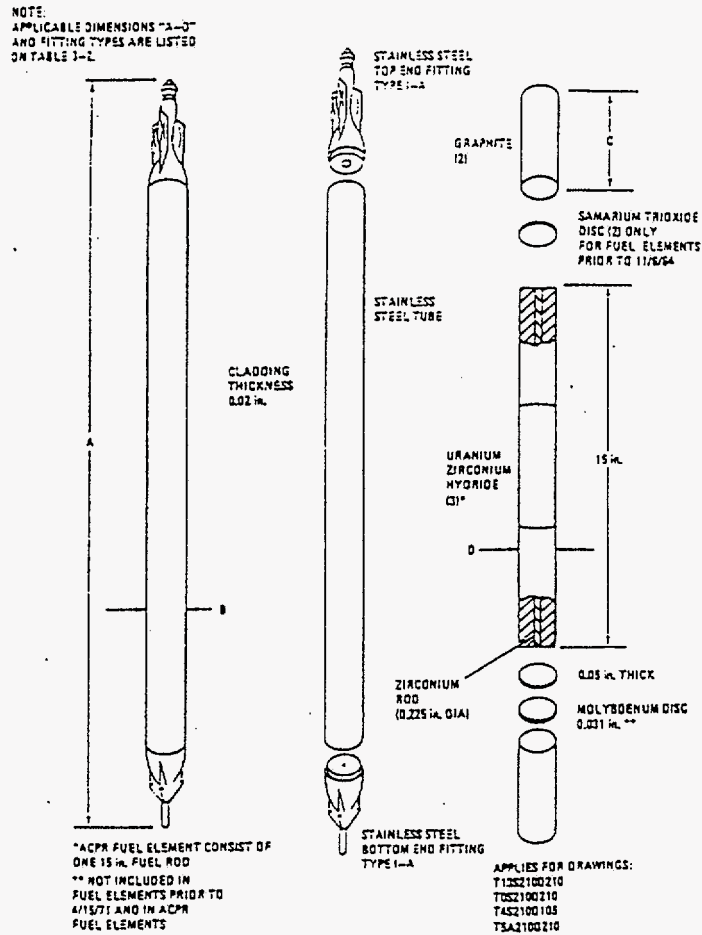

Drawing No.	TRIGA Fuel Type	Fitting Type	A (in.)	B (in.)	C (in.)	D (in.)
T13S210D210	Standard-streamline	I-A	29.63	1.478	2.56(a)	1.435
TOS210D210	Standard-plain	II-A	28.9	1.478	3.42	1.435
T4S210D105	4 rod cluster	III-A	29.88	1.414	3.42	1.37
T5A210D210	ACPR	IV-A	28.89	1.478	3.45	1.40

(a) Lower graphite is longer than upper graphite. Lower graphite - 3.72 in.

Figure 5-4. Sketch of Stainless Steel-Clad TRIGA Rods, TRIGA-SS

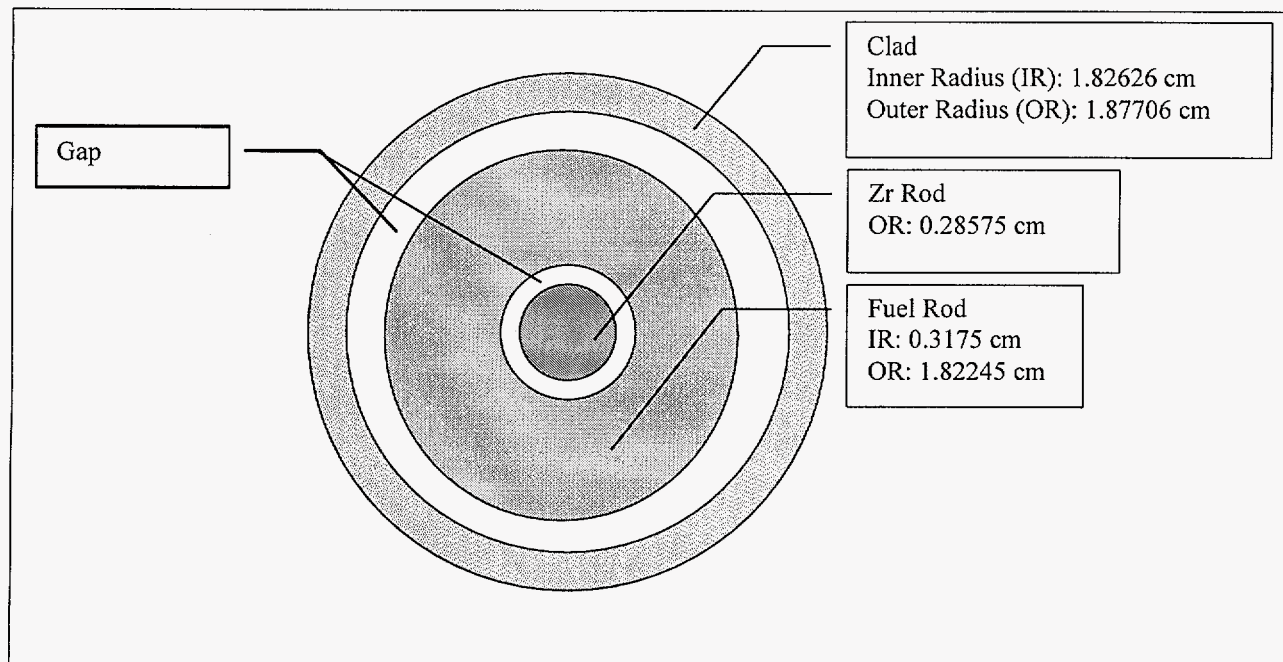

Figure 5-5. Cross-Sectional Sketch of a TRIGA-SS Rod (not to scale)

Table 5-1 shows the components and materials of these rods (DOE 1999, p. 10). The beginning of life (BOL) U-235 enrichment for the many variations of these stainless steel-clad rods is 20 wt%, except for the Fuel Life Improvement Program (FLIP) rod that is 70 wt% (DOE 1999, p. 12). It is stated on page 19 of DOE (1999) that the most reactive rod is the four-rod cluster type TRIGA-SS FLIP. However, results given in Table 6-1 show that the k_{eff} value of a WP containing standard streamline rods is statically identical to the k_{eff} value of a WP containing four-rod cluster rods. In this calculation, the standard streamline type rods are studied.

Table 5-1. Stainless Steel-Clad TRIGA Rods Components and Materials

Component	Material
Fuel	Uranium Zirconium Hydride
Center Rod	Zirconium
Burnable Neutron Absorber Discs	Samarium Trioxide
Reflectors	Graphite
Cladding	Stainless Steel (Type 304)
Fittings	Stainless Steel (Type 304)
Tubing	Stainless Steel

There are five variations for the uranium loading of the standard streamline type rods. Before 1965, the standard (TRIGA-SS Standard) rods were U20ZrH1.0 fuel rods loaded with 39 g U-235, 8% of the total fuel mass being uranium. After 1965, the TRIGA-SS standard rods were U20ZrH1.7 fuel rods loaded with 39 g U-235, 8.5-9% of the total fuel mass being uranium. Also, there are three types of TRIGA-SS FLIP loading; namely TRIGA-SS FLIP, TRIGA-SS FLIP Low Enriched Uranium (FLIP-LEU-I), and TRIGA-SS FLIP-LEU-II. The TRIGA-SS FLIP rods are U70ZrH1.6 fuel rods loaded with 137 g U-235, 8.5% of the total fuel mass being uranium. The TRIGA-SS FLIP-LEU-I rods are U20ZrH1.6 fuel rods loaded with 101 g U-235, 20% of the total fuel mass being uranium. TRIGA-SS FLIP-LEU-II rods are U20ZrH1.6 fuel rods loaded with 165 g U-235, 30% of the total fuel mass being uranium. Table 5-2 summarizes these and the ACPR rod loadings (DOE 1999, p. 14).

Table 5-2. Stainless Steel-Clad Fuel Elements Initial Loadings

Designation	Initial Uranium Content (wt%)	Initial Uranium-235 Enrichment (wt%)	H/Zr Atom Ratio
Standard—Prior to 11/6/64	8.0	20.0	1.0
Standard—1965 on	8.5-9.0	20.0	1.7
FLIP ^a	8.5	70.0	1.6
LEU-I ^b	20.2	20.0	1.6
LEU-II	30.0	20.0	1.6
ACPR ^c	12.0	20.0	1.7

a) Fuel Life Improvement Program.

b) LEU: Low Enriched Uranium.

c) Annular Core Pulsed Reactor (loading applies only to TRIGA ACPR fuel elements).

5.1.5 Materials Compositions

Tables 5-3 through 5-9 provide the composition of the materials used in the codisposal WP.

Table 5-3. Composition of SS 304L*

Element	Weight Percent
C	0.030
N	0.100
Si	0.750
P	0.045
S	0.030
Cr	19.000
Mn	2.000
Ni	10.000
Fe	68.045
Density = 7.94 g/cm ³	
* CRWMS M&O (1999b, p. 17)	

Table 5-4. Composition of Alloy 22 (UNS* N06022)**

Element	Weight Percent	Element	Weight Percent
C	0.015	Si	0.080
P	0.020	S	0.020
V	0.350	Cr	21.250
Mn	0.500	Fe	4.000
Co	2.500	Ni	54.765
Mo	13.500	W	3.000
Density at 24°C = 8.69 g/cm ³			
* Universal Numbering System			
** CRWMS M&O (1999b, p. 30)			

Table 5-5. SRS HLW Glass Chemical Composition

Element / Isotope	Weight Percent	Element / Isotope	Weight Percent
O	4.4770E+01	Ni	7.3490E-01
U-234	3.2794E-04	Pb	6.0961E-02
U-235	4.3514E-03	Si	2.1888E+01
U-236	1.0415E-03	Th	1.8559E-01
U-238	1.8666E+00	Ti	5.9676E-01
Pu-238	5.1819E-03	Zn	6.4636E-02
Pu-239	1.2412E-02	B-10	5.9176E-01
Pu-240	2.2773E-03	B-11	2.6189E+00
Pu-241	9.6857E-04	Li-6	9.5955E-02
Pu-242	1.9168E-04	Li-7	1.3804E+00
Cs-133	4.0948E-02	F	3.1852E-02
Cs-135	5.1615E-03	Cu	1.5264E-01
Ba-137**	1.1267E-01	Fe	7.3907E+00
Al	2.3318E+00	K	2.9887E+00
S	1.2945E-01	Mg	8.2475E-01
Ca	6.6188E-01	Mn	1.5577E+00
P	1.4059E-02	Na	8.6284E+00
Cr	8.2567E-02	Cl	1.1591E-01
Ag	5.0282E-02		
Density at 25 °C = 2.85 g/cm ³ (Stout and Leider 1991, p. 2.2.1.1-4)			
* CRWMS M&O (1999d, p. 7)			
** See Assumption 3.6			

Table 5-6. Composition of A 516 Carbon Steel Grade 70*

Element	Weight Percent	Element	Weight Percent
C	0.300	Mn	1.025
Si	0.275	S	0.035
P	0.035	Fe	98.33
Density = 7.85 g/cm ³			
* CRWMS M&O (1999b, p. 17)			

Table 5-7. Composition of Fuel Types FLIP and FLIP-LEU-I (Attachment III, Excel file named "gd compo.xls" & INEEL 1999, pp. 20 and 29)

Element / Isotope	Fuel Type FLIP Atomic Density (atom/barn-cm)	Fuel Type FLIP-LEU-I Atomic Density (atom/barn-cm)
H	5.6444E-02	5.4149E-02
Zr	3.5278E-02	3.3843E-02
U-235	9.1057E-04	6.6732E-04
U-238	3.8719E-04	2.6291E-03
Nominal Density	6.02 g/cm ³	6.02 g/cm ³
Calculated Density (for a standard streamline rod)	5.95 g/cm ³	6.52 g/cm ³

Table 5-8. Composition of Stainless Steel 316L*

Element	Weight Percent	Element	Weight Percent
C	0.030	Mn	2.000
P	0.045	S	0.030
Si	1.000	Cr	17.000
Ni	12.000	Mo	2.500
N	0.1	Fe	65.295
Density = 7.98 g/cm ³			
* CRWMS M&O (1999b, p. 13)			

Table 5-9. Composition of the Advanced Absorber Matrix (Alloy 22 with 8 atom % of Gd)*

Element	Weight Percent	Element	Weight Percent
C	0.012	Mn	0.409
Si	0.065	Cr	17.369
Mo	11.034	Co	2.043
W	2.452	V	0.286
Fe	3.269	P	0.016
S	0.016	Gd	18.264
Ni	44.763		
Density** = 8.55 g/cm ³			
* Attachment III, Excel file named "gd compo.xls"			
** The density is calculated using the density of the Alloy 22, the density of Gd, and the weight percentage of Gd in the Alloy 22 (see Attachment III, Excel file named "gd compo.xls").			

Table 5-10. Composition of Stainless Steel 304*

Element	Weight Percent	Element	Weight Percent
C	0.08	Cr	19
Ni	9.25	Mn	2
P	0.045	S	0.03
Si	1.0	N	0.1
Fe	68.495		
Density = 7.94 g/cm ³			
* CRWMS M&O (1999b, p. 20)			

The Graphite density is 1.73 g/cm³ (Lynch 1975, p. 367). The density of Zr is 6.49 g/cm³ (CRC Press 1985, p. B-160). Atomic masses and densities are taken from Parrington et al. (1996) unless otherwise specified. The atomic mass of Pu-241 is taken from page 976 of Benedict et al. (1981). The dimensions used to represent the WP and the DOE SNF canister are shown in Figure 5-6.

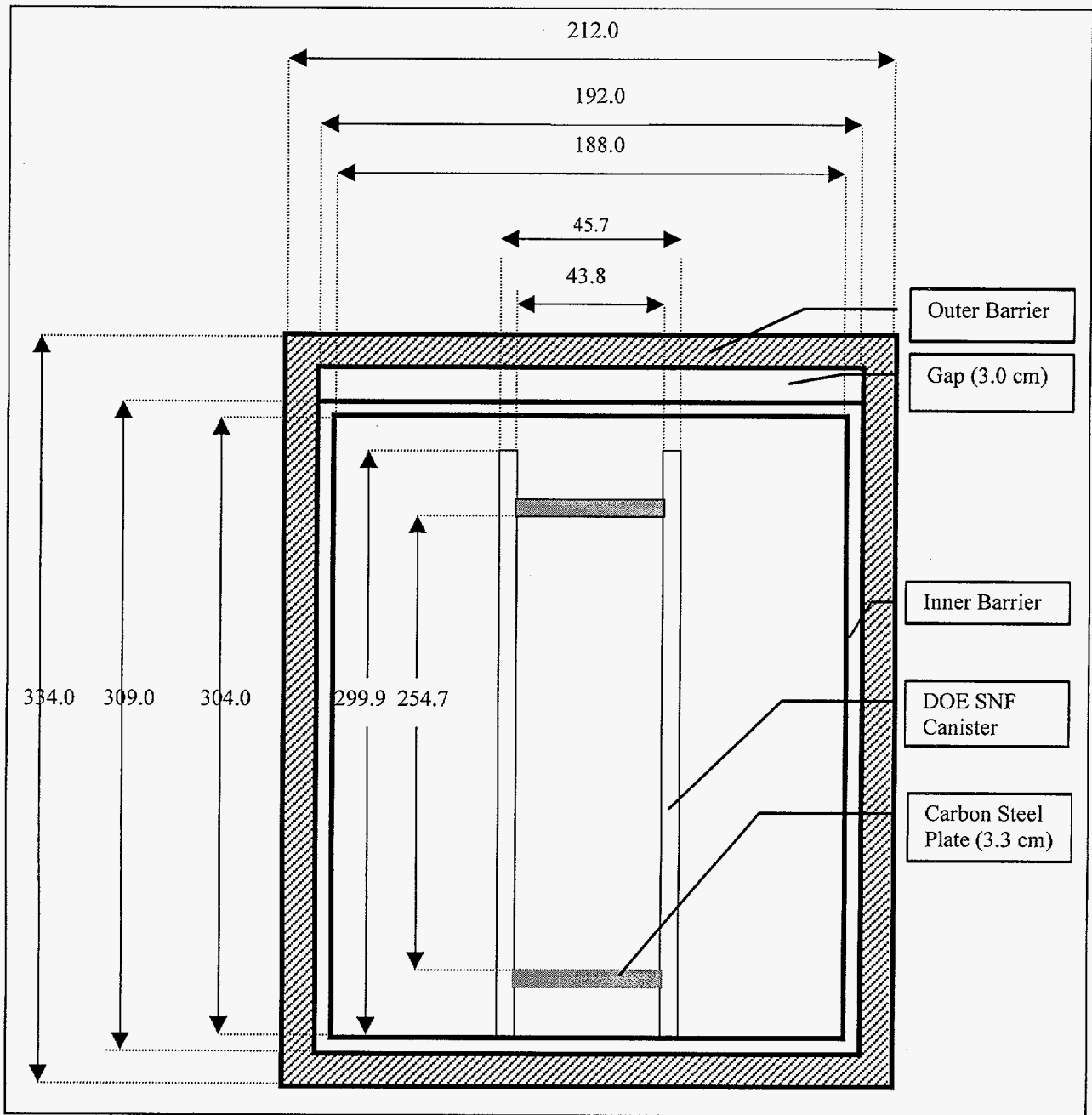

Figure 5-6. WP and DOE SNF Canister Dimensions (in cm) Used in this Calculation (not to scale)

5.1.6 Intact Cases

Material volumes and densities used to generate the number densities are provided in Attachment III, Excel file named "05-24-99.xls". The composition of the degraded SRS HLW glass clayey material is given in Attachment III, Excel files named "EQ6 runs.xls" and "Allde_EQ6.xls". The equation used to calculate the number density values throughout Section 5 is shown below:

$$N = (m/V) \times N_a / M$$

where: N is the number density in atoms/barn · cm
 m is the mass in grams
 V is the volume in cm³
 N_a is the Avogadro's number (6.022 E+23 atoms/mole, Parrington et al. 1996, p. 59)
 M is the atomic mass in g/mole.

Volumes of a cylinder segment (volume = segment of a circle × length of the cylinder) are also calculated throughout Attachment III. The equation for the segment of a circle is shown below (Beyer 1987, p. 125):

$$\text{Segment of a Circle} = \left(R^2 \cos^{-1} \left(\frac{R-h}{R} \right) - (R-h) \sqrt{2Rh - h^2} \right)$$

where: R is the cylinder radius
 h is the height of the segment.

The reactivity of the intact configuration was studied. Two types of fuel are represented: the FLIP and the FLIP-LEU-I. Figures 5-1 and 5-7 give a representation of the intact case. The upper and lower end-fitting of each fuel rod are represented as a cylinder in the intact cases (see Table 6-1). The mass and density of the upper and lower end-fitting (CRWMS M&O 1999c, p. 7) are used for the other configurations.

The MCNP input files developed for this section are presented in Attachment I (the electronic reference is CRWMS M&O 1999a). The MCNP output files are presented in Attachment II (the electronic reference is CRWMS M&O 1999a).

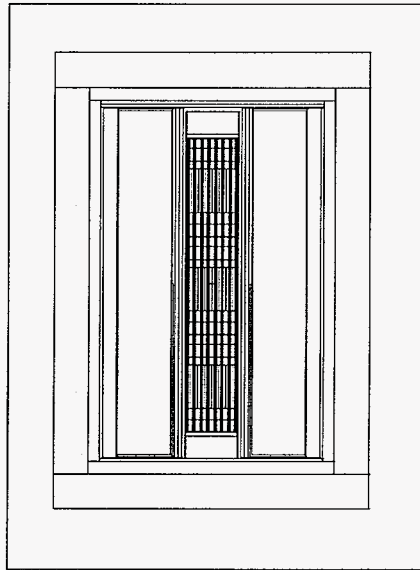

Figure 5-7. Longitudinal Cross Section of the DOE SNF Canister

5.2 DEGRADED CASES

The criticality evaluations conducted for the degraded cases are discussed in the following sections. Several configurations are considered. Detailed descriptions of these configurations are given on pages 27 through 37 of CRWMS M&O (1999e). In Section 5.2.1, configurations are analyzed resulting from the degradation scenarios in which the waste form (TRIGA Fuel) degrades before the other internal components (OIC) of the WP (CRWMS M&O 1999e, pp. 27-29). In Section 5.2.2, configurations resulting from degradation scenarios in which the waste form (WF) degrades after the OIC of the WP are discussed (CRWMS M&O 1999e, pp. 30-31). In configurations resulting from a flow through the WP, it has been shown (CRWMS M&O 1999f) that the fissile material will be flushed out of the WP. This eliminates the risk of internal criticality. In the calculation described below, the fuel type is FLIP unless otherwise specified. The dimensions used to represent the WP and the DOE SNF canister are shown in Figure 5-6.

The MCNP input files developed for this section are presented in Attachment I (the electronic reference is CRWMS M&O 1999a). The MCNP output files are presented in Attachment II (the electronic reference is CRWMS M&O 1999a).

In this calculation, the terms “fraction of water” or “percent of water” refer to a volume fraction or to a percentage of volume. The DOE SNF canister is always considered to be flooded and the WP is dry unless otherwise specified.

In the following, the term advanced absorber matrix refers to the Alloy 22 with 8 atom % of Gd whose composition is given in Table 5-9. The advanced absorber matrix can be either placed on the inner surface of the tube of the basket or on the outer surface of the tube of the basket. If the

advanced absorber matrix is placed on the inside of the basket's tubes, it has a 1-mm thickness and covers the length of the tube. If it is placed on the outside of the basket tubes, it is flame sprayed and has a 0.1-mm thickness and covers the length of the tube.

5.2.1 Waste Form Degrades Before the Other Internal Components

In the cases described in this section, the WF degrades faster than the surrounding components (CRWMS M&O 1999e, p. 27). The WP and the DOE SNF canister are considered to be breached at the top with water dripping inside. The following presents the different configurations analyzed under this scenario.

5.2.1.1 WF Degrades but the DOE SNF Canister and the Basket are Intact

In this configuration group, the WF degrades first (the clad surrounding the waste form degrades first, then the fuel). All the OIC of the WP remain intact.

Clad Degrades. Several cases are developed which considered the basket and the DOE SNF canister intact. The web-like structure, the SRS HLW glass pour canister and the SRS HLW glass are also intact. The stainless steel clad degrades (see Assumption 3.1) but the fuel is not degraded yet. The goethite settles in each tube and is either accumulated on the bottom of each tube or homogenized over the volume of the tube. The gap between the Zr rod and the fuel rod is filled with water. The amount and location of the advanced absorber matrix coat varies. Other cases where the Zr rod is replaced by water are analyzed. Figure 5-8 shows the cross section of the WP in this configuration.

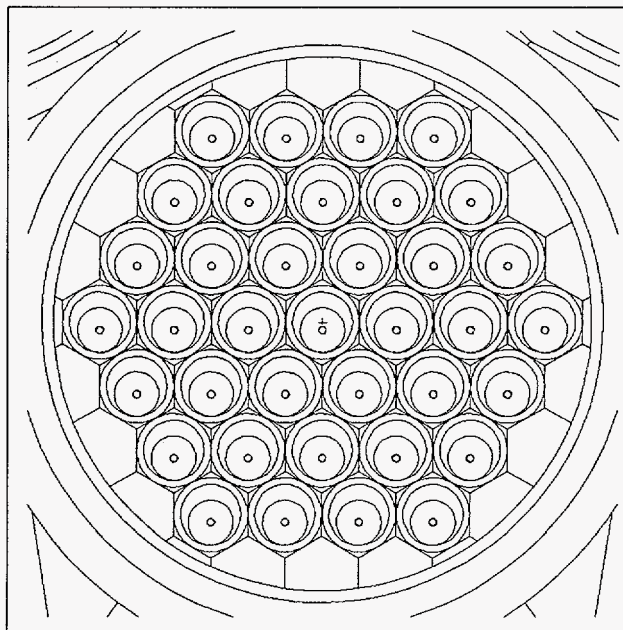

Figure 5-8. Cross Section of DOE SNF Canister (basket intact, clad degraded)

Fuel Degrades. The following configuration group is similar to the previous one except that the fuel degrades. Cases where the fuel is breached and is partially fractured are analyzed. The pieces of fuel are represented as sphere. The radius of the sphere varies for each case. In this set of cases, the graphite reflectors and the Zr rod are intact and positioned as they are in the intact configuration, but the clad is degraded. A homogenized mixture of water and degraded stainless steel surrounds each sphere. Figure 5-9 shows the cross section of the SNF canister in this configuration.

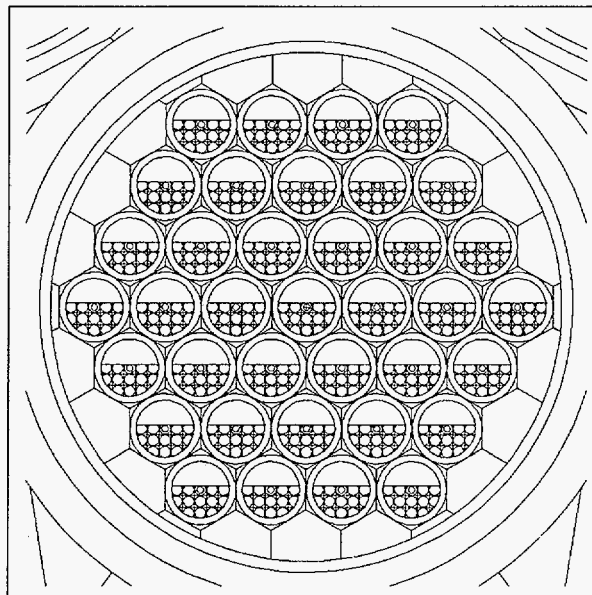

Figure 5-9. Cross Section of DOE SNF Canister (fuel partially fractured)

In the next configuration analyzed, the uranium (U) is assumed to have been separated from the Zr in the fuel. The uranium spheres of radius 0.001 cm are assumed to have settled onto the bottom of the DOE SNF canister; surrounded by a homogenized mixture of goethite and water, and covered by a layer of zircaloy-hydride (ZrH_x) mixture. The rest of the DOE SNF canister was filled with a homogenized mixture of degraded stainless steel and water. In this configuration, a case was analyzed where the ZrH_x was replaced by ZrO_2 , its oxidized form.

A configuration is studied where the fuel element (fuel matrix, clad, Zr rod, and graphite reflectors) is fully degraded and the basket is still intact. In these cases, the percentage of water in the clay resulting from the degradation of the fuel element varies.

5.2.1.2 WF and Basket Degrade but the DOE SNF Canister, SRS HLW Glass, SRS HLW Glass Pour Canister, and Web-Like Structure are Intact

In this configuration group, the basket degrades. As a result of this degradation, the degraded fuel element will fall onto the bottom of the DOE SNF canister. Different stages of degradation of the fuel element are considered:

Clad Surrounding the Fuel is Degraded. In this configuration the bare fuel pins have settled onto the bottom of the DOE SNF canister. The degradation product of both the clad and the basket surrounds the fuel pins. Water is added to the degradation product. A representation of this configuration is shown in Figure 5-10. When present, the advanced absorber matrix coating is degraded and mixed with the goethite. The number and locations of the coated rods, and the thickness of the coating vary.

Several cases are developed where the advanced absorber matrix is degraded but not mixed with the degraded products. A case is developed where the advanced absorber matrix coating has fallen onto the bottom of the DOE SNF canister forming a layer with fuel rods sitting on this layer. Another case considers the accumulation of advanced absorber matrix coating among rods as it degrades (Figure 5-11).

Degraded Clad and Partially Fractured Fuel. The pieces of the fuel are represented as spheres. The radius of the spheres varies. A mixture of water and degraded stainless steel surrounds each sphere. In this series, the graphite reflector and the Zr rods form layers above the goethite. The advanced absorber matrix coating is neglected in this configuration.

Fully Degraded Fuel, Zr Rods, Graphite Reflector, and Clad. In this configuration, the fuel and the degraded product of both the clad and the basket form a slurry. The fuel rods are partially fractured and represented as spheres. The amount of water in this slurry varies. A representation of this configuration is shown in Figure 5-12.

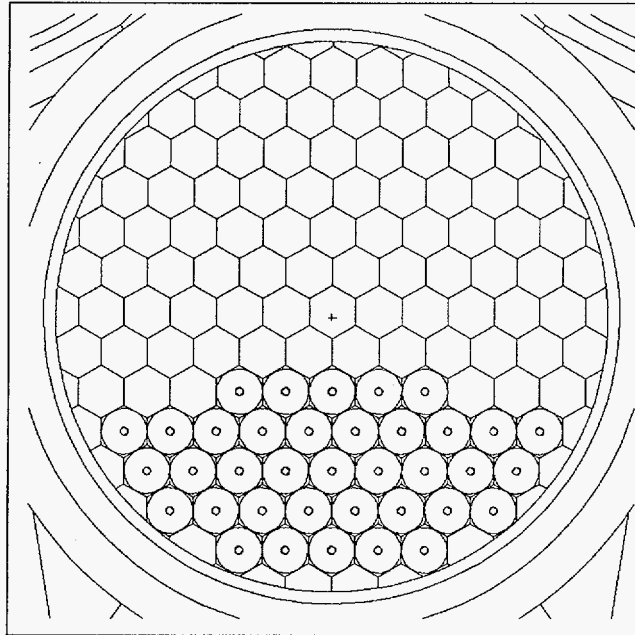

Figure 5-10. Cross Section of DOE SNF Canister (SS tubes degraded)

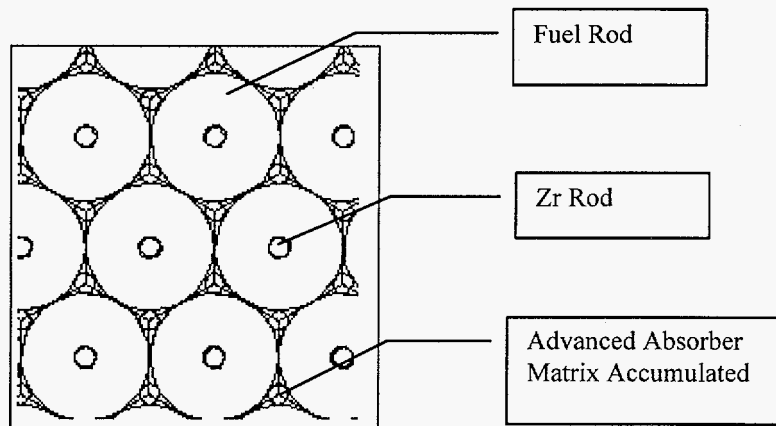

Figure 5-11. Cross Section of DOE SNF Canister (advanced absorber matrix accumulated among the rods)

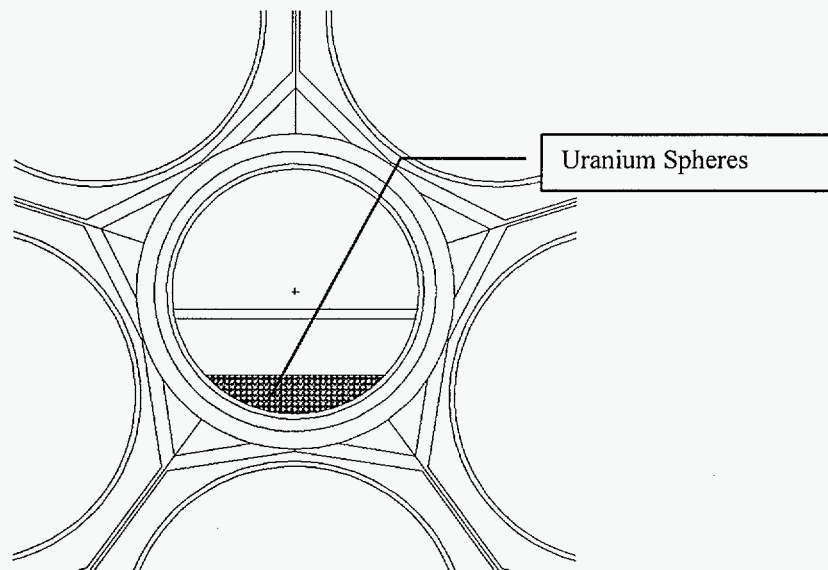

Figure 5-12. Cross Section of the DOE SNF Canister (the fuel degrades)

5.2.1.3 All WP Components Degrade

In this section, configurations resulting from the final stage of any degradation scenario are evaluated. In these configurations, all components of the WP are in a degraded form (clay). The composition of this clay is given on page 43 of CRWMS M&O (1999f). Different volumes of water are added to this mixture. Composition and volume of the clay in these configurations are given in Attachment III, Excel file named "alldc_EQ6.xls".

5.2.2 Waste Form Degrades After the Other Internal Components

In the cases described in this section, the flooded components external to the DOE SNF canister are being the first ones exposed to aqueous attack, and start to degrade first (CRWMS M&O 1999e, p. 31). The web-like structure (made of carbon steel) degrades fastest and much of the SRS HLW glass has degraded before water penetrates the DOE SNF canister. Then the DOE SNF canister starts to degrade.

In the following sections, different stages of degradation of the DOE SNF canister and its internal components are analyzed given that the OIC of the WP are fully degraded.

5.2.2.1 DOE SNF Canister Intact

In this group of configurations, the DOE SNF canister is partially intact; it has degraded on the outer surface only (CRWMS M&O 1999f, p. 46). The composition of the clay outside the DOE SNF canister (results of the degradation of the web-like structure, the SRS HLW glass pour canister and the SRS HLW glass) is given on page 43 of CRWMS M&O (1999f). The amount of intact 304L from the SRS HLW glass pour canister (CRWMS M&O 1999f, p. 46) is added to this composition. Different volumes of water are mixed with this clay. The compositions of these mixtures are given in the file named "alldc_EQ6.xls", spreadsheet "all but DOESNF" (Attachment III). The canister either sits on the bottom of the WP or is located in the upper part of the clay. Different stages of degradation of the internal components of the DOE SNF canister are considered:

- Only the clad is degraded, the basket and the fuel are still intact.
- The clad and the basket are degraded, the fuel rods are confined at the bottom of the DOE SNF canister. A cross section of the WP in this configuration is shown in Figure 5-13.
- All the internal components of the DOE SNF canister are degraded.

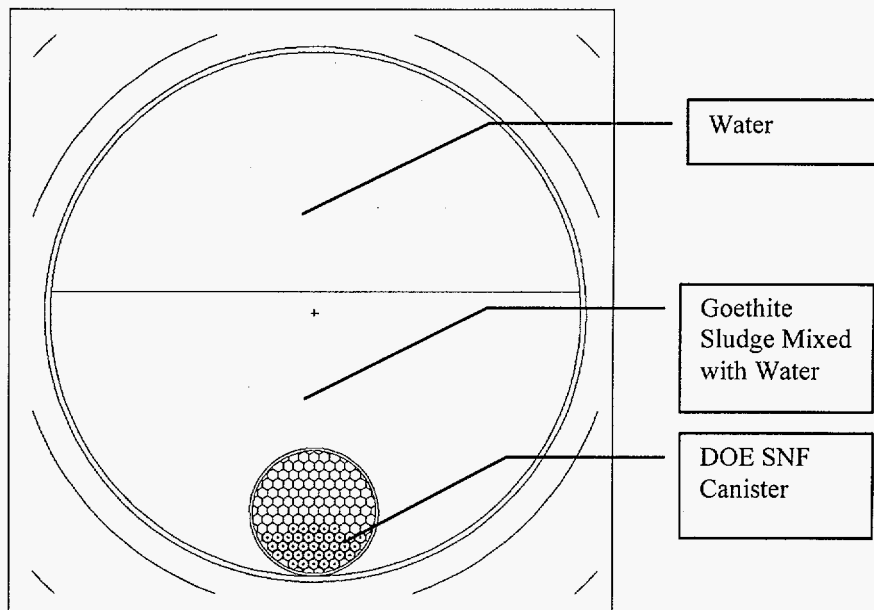

Figure 5-13. Cross Section of a Degraded WP

5.2.2.2 Waste Form Intact, Other Internal Component Degraded

In this group of configurations, all the internal components of the WP are degraded but the fuel is intact. The composition of the clay resulting from the degradation of these materials is calculated as follows:

The composition of the intact fuel matrix is subtracted from the composition of the clay resulting from the degradation of the all components in the WP (CRWMS M&O 1999f, p. 43). Different volumes of water are added to this mixture. The compositions obtained are given in the spreadsheet “all but fuel” located in the file “alldc_EQ6.xls” in Attachment III.

A configuration where the intact WF is surrounded by clay and stacked at the bottom of the WP (in a highly unlikely configuration) is analyzed. Gd is added in the WP. Figure 5-14 shows a cross section of the WP in this configuration.

Then the WF degrades and is confined at the bottom of the WP with the clay above it. Figure 5-15 shows a cross section of the WP in this configuration.

The last stage of degradation for this scenario is identical to the one described in Section 5.2.1.3.

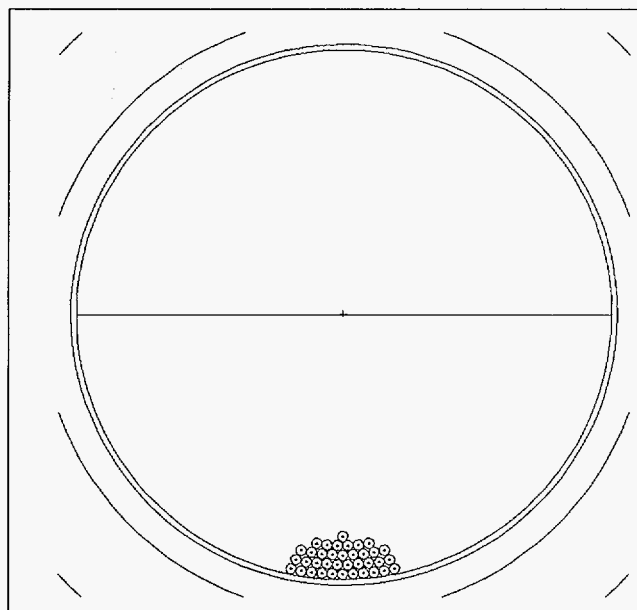

Figure 5-14. Cross Section of the WP with the WF Intact at the Bottom

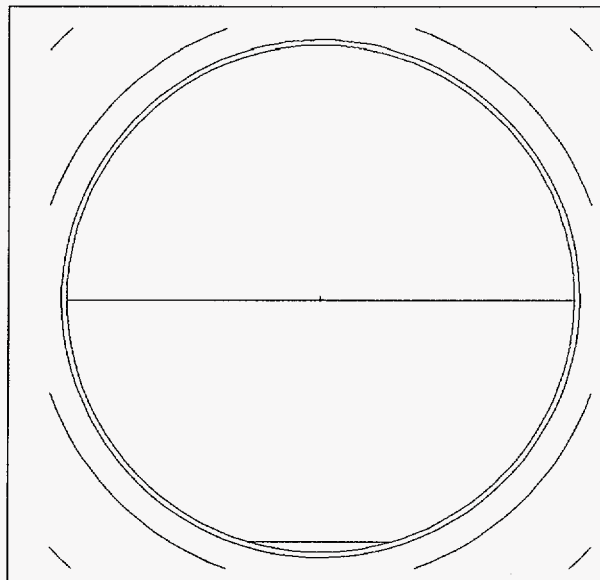

Figure 5-15. Cross Section of the WP with the WF Degraded at the Bottom

5.2.3 Intermediate Degraded Configuration

In this section, a configuration using inputs from CRWMS M&O (1999f) is developed (CRWMS M&O 1999f, pp. 40 and 41, cases 13 and 14). This case was selected because it is the worst case found in the geochemistry calculation from a criticality point of view; most of the fissile material (99%) is still in the waste package and only 46% of the Gd remains in the WP. In this configuration, the glass is quasi intact but the DOE SNF canister is fully degraded and the WF is partially degraded. All the degraded components are in clay whose composition is given in the spreadsheet "Corrosion only" located in the file "EQ6 runs.xls" in Attachment III. A cross section of the WP in this configuration is given in Figure 5-16.

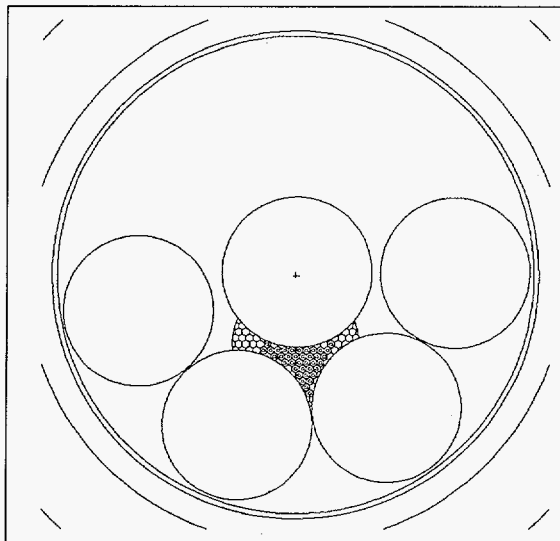

Figure 5-16. Cross Section of the WP in an Intermediate Degradation Stage

6. RESULTS

This calculation documents various intact and degraded configurations of the TRIGA fuel codisposal WP. Sections 6.1 and 6.2 present the k_{eff} for each configuration. The k_{eff} results represent the average collision, absorption, and track length estimator from the MCNP calculations. The standard deviation (σ) represents the standard deviation of k_{eff} about the average combined collision, absorption, and track length estimate due to Monte Carlo calculation statistics. Also given in Tables 6-1 through 6-14 are the average energy of neutron causing fission in MeV (AENCF) and the hydrogen/fissile material (U-235 in this calculation) atom ratio (H/X atom ratio). For the intact cases, the H/X atom ratio is calculated over the volume of one of the basket tubes. For the degraded cases, the H/X atom ratio is calculated over the volume that contains the degraded fuel. H/X atom ratios are given in Attachment III, Excel file named "05-24-99.xls" spreadsheet "HtoXratio". All the results are listed in Attachment III, Excel file named "res.xls".

Unqualified data were used in the development of the results presented in this section. If the results from this section are used as input into documents directly relied upon for safety or waste isolation issues, then they are required to be identified and tracked as TBV in accordance with appropriate procedures.

6.1 INTACT CASES

In this section, results of the calculations described in Section 5.1.6 are presented. Table 6-1 gives the k_{eff} of the intact configuration assuming that the fuel is the TRIGA FLIP type or the FLIP-LEU-I type. Two types of rod are considered: the standard-streamline and the 4-rod cluster. Both the DOE SNF canister and the WP are flooded unless otherwise specified.

Table 6-1. Results for the Intact Configuration with Different Fuel Types

File Name	k_{eff}	$k_{eff}+2\sigma$	AENCF (MeV)	H/X Atom Ratio	Fuel Type
intact.O*	0.7874	0.7890	0.0267	279	FLIP.
int_08.O	0.7736	0.7753	0.0276	235	FLIP (water density=0.8 g/cm ³).
int_05.O	0.7380	0.7395	0.0315	170	FLIP (water density=0.5 g/cm ³).
int_03.O	0.7019	0.7035	0.0348	127	FLIP (water density=0.3 g/cm ³).
intaFL.O	0.6883	0.6911	0.0451	375	FLIP-LEU-I.
4rod6.O*	0.7907	0.7926	0.0265	279	FLIP in a 4-rod cluster rod.
int12a.O	0.5843	0.5858	0.0347	279	FLIP with a 1 mm of advanced absorber matrix tube on the inner surface** of 36 tubes (3 x 12). Configuration 1 (Figure 6-1).

Table 6-1. Results for the Intact Configuration with Different Fuel Types (continued)

File Name	k_{eff}	$k_{eff}+2\sigma$	AENCF (MeV)	H/X Atom Ratio	Fuel Type
inta12.O	0.6880	0.6894	0.0308	279	FLIP with a 1 mm of advanced absorber matrix tube on the inner surface** of 36 tubes. Configuration 2 (Figure 6-1).
intaou.O	0.6115	0.6130	0.0348	279	FLIP with a 0.1 mm of advanced absorber matrix coat on the outer surface** of 111 tubes.
indry.O	0.6239	0.6253	0.0447	62	FLIP, the WP, and the DOE SNF canister are dry.
int_1.O	0.8188	0.8204	0.0254	279	The fuel is homogenized over the free volume in the clad (gaps in the clad and the fuel rod are filled with fuel and water).
int_2.O	0.8150	0.0252	0.0252	279	Water is added to the fuel to reach the theoretical density (6.02 g/cm ³ , DOE 1999, p. 20).

* These two results are statistically identical.
 ** No space between the stainless steel tube and the advanced absorber matrix.

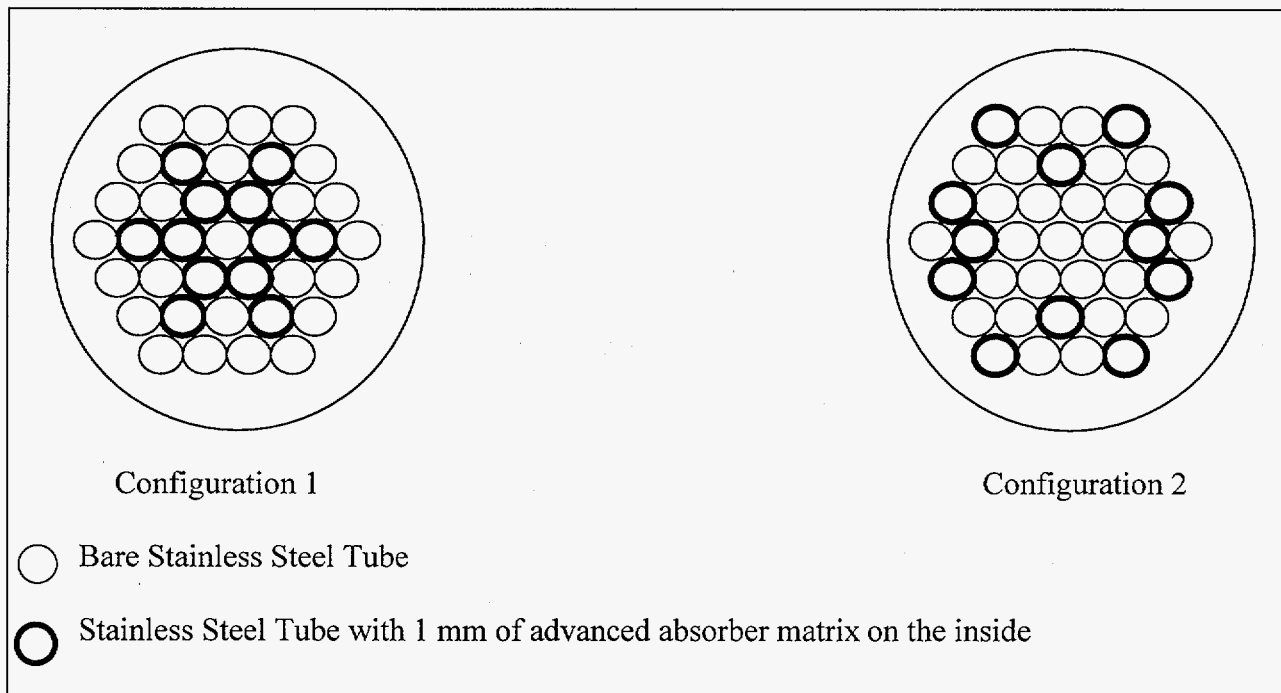

Figure 6-1. Emplacement of the Advanced Absorber Matrix Coat

6.2 DOE SNF CANISTER DEGRADED

In the following section, k_{eff} values for a WP with a degraded DOE SNF canister (degraded basket) are presented.

6.2.1 Waste Form Degrades Before the Other Internal Components

6.2.1.1 WF Degrades but the DOE SNF Canister and the Basket are Intact

Results of the calculations described in section 5.2.1.1 are in Tables 6-2 through 6-5.

The results for the configuration where the stainless steel clad has degraded and the bare fuel rods sit on the bottom of the pipe surrounded by goethite are presented in Table 6-2.

Table 6-2. Results for the Configuration with the Basket of the DOE SNF Canister Intact, the Fuel Rod Clad Degraded

File Name	k_{eff}	$k_{\text{eff}}+2\sigma$	AENCF (MeV)	H/X Atom Ratio	Description
set1_1.O	0.6620	0.6649	0.0329	227	Degraded clad and water homogenized over the entire volume of the tube (45 [3 × 15] tubes are coated with a 1-mm thick advanced absorber matrix)*.
set1_2.O	0.6639	0.6655	0.0322	227	Degraded clad with 66% void filled with water. Water fills the canister. 45 tubes are coated with a 1-mm thick advanced absorber matrix*.
set1_3.O	0.6638	0.6656	0.0324	227	Degraded clad with 40% void filled with water. Water fills the canister. 45 tubes are coated with a 1-mm thick advanced absorber matrix*.
set1_4.O	0.8045	0.8069	0.0266	227	Degraded clad with 77% void filled with water, no advanced absorber matrix coating.
set108	0.7958	0.7985	0.0272	195	Like case set1_4 but density of the water is 0.8 g/cm ³ .
set105	0.7709	0.7735	0.0290	147	Like case set1_4 but density of the water is 0.5 g/cm ³ .
set103	0.7494	0.7519	0.0310	115	Like case set1_4 but density of the water is 0.3 g/cm ³ .
set1_5.O	0.6560	0.6587	0.0327	227	Degraded clad and water homogenized over the entire volume of the tube (45 tubes are coated with a 1-mm advanced absorber matrix thickness)*. The WP is flooded.

Table 6-2. Results for the Configuration with the Basket of the DOE SNF Canister Intact, the Fuel Rod Clad Degraded (continued)

File Name	k_{eff}	$k_{eff}+2\sigma$	AENCF (MeV)	H/X Atom Ratio	Description
set1_6.O	0.6061	0.6089	0.0557	305	Degraded clad and water homogenized over the entire volume of the tube (45 tubes are coated with a 1-mm advanced absorber matrix thickness)*. The fuel type is FLIP-LEU-I.
set1_7.O	0.6698	0.6724	0.0321	227	Degraded clad and water homogenized over the entire volume of the tube (45 tubes are coated with a 1-mm advanced absorber matrix thickness)*. No Zr rod.
set1_8.O	0.6114	0.6139	0.0350	251	Degraded clad and water homogenized over the entire volume of the tube. All the tubes have a 0.1-mm coat of advanced absorber matrix deposit on the outside.

* See Figure 6-2

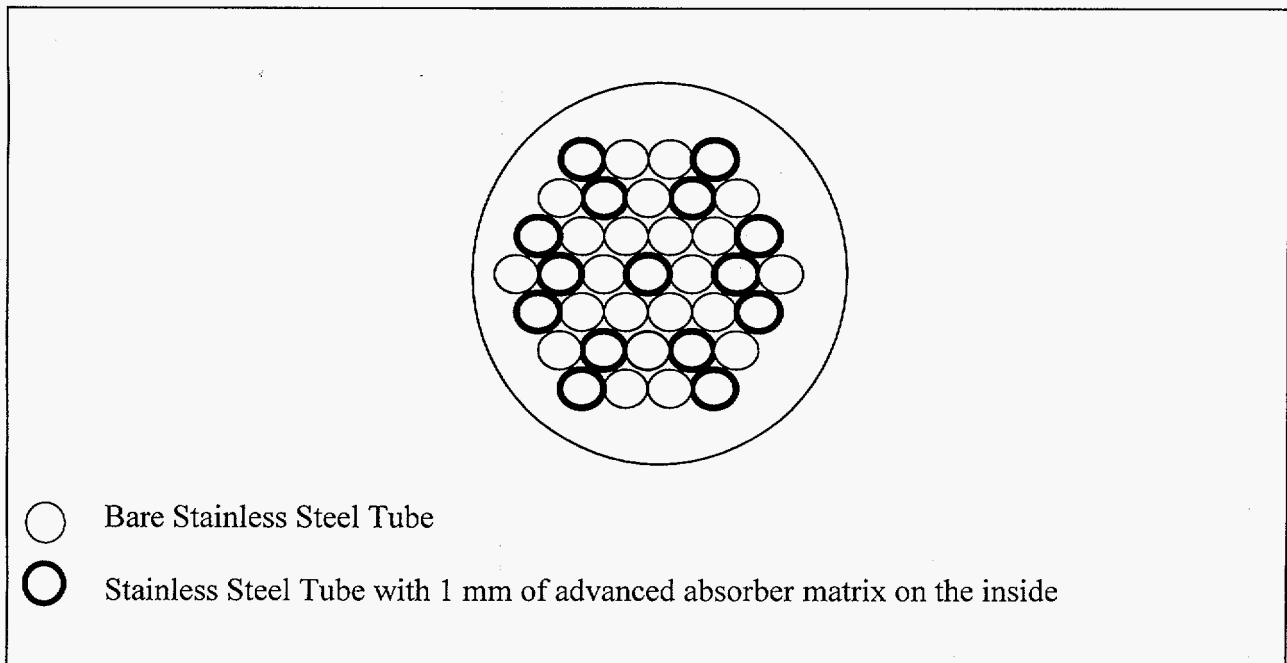

Figure 6-2. Cross Section of the DOE SNF Canister with the Emplacement of 45 ([15 stainless steel tubes with the advanced absorber matrix per layer] * [3 layers]) Advanced Absorber Matrix Coated Tubes

In the next set of cases, the fuel is assumed to have breached. The advanced absorber matrix coating is not present in the DOE SNF canister. Table 6-3 lists the results obtained for this configuration.

Table 6-3. Results for the Configuration with the Fuel Partially Fractured

File Name	k_{eff}	$k_{eff}+2\sigma$	AENCF (MeV)	H/X Atom Ratio	Sphere Radius
set2_1.O	0.6606	0.6623	0.0184	227	0.1 cm
set2_2.O	0.7508	0.7525	0.0176	227	0.5 cm
set2_3.O	0.7604	0.7621	0.0183	227	1.0 cm

The results assuming that the uranium separates from the Zr are presented in Table 6-4.

Table 6-4. Results for the Configurations where the U Separates from the ZrH_x

File Name	k_{eff}	$k_{eff}+2\sigma$	AENCF (MeV)	H/X Atom Ratio	Description
set3_1.O	0.5025	0.5048	0.2200	227	Dry ZrH _x on the top of a layer of U DOE SNF is flooded.
set3_2.O	0.5068	0.5088	0.2413	165	ZrH _x replaced by ZrO ₂ .

Table 6-5 presents the results for the configuration where the fuel elements are fully degraded.

Table 6-5. Results for the Configuration with Fuel Element Fully Degraded

File Name	k_{eff}	$k_{eff}+2\sigma$	AENCF (MeV)	H/X Atom Ratio	Description
set6_1.O	0.6496	0.6512	0.0184	67	The clay resulting from the degradation of the fuel is dry.
set6_2.O	0.6726	0.6743	0.0170	93	The clay resulting from the degradation of the fuel has 20% water.
set6_3.O	0.7234	0.7252	0.0143	137	The clay resulting from the degradation of the fuel has 40% water.
set6_4.O	0.7958	0.7974	0.0118	224	The clay resulting from the degradation of the fuel has 60% water.
set6_5.O	0.8141	0.8158	0.0112	267	The clay resulting from the degradation of the fuel has 65.7% water (tube full).

6.2.1.2 WF and Basket Degrades but the DOE SNF Canister, SRS HLW Glass, SRS HLW Glass Pour Canister, and Web-Like Structure are Intact

The results of the calculation described in Section 5.2.1.2 are presented in Tables 6-6 through 6-8. In this configuration, the basket is assumed fully degraded; however, the canister is still intact. The remains of the fuel rods sit at the bottom of the DOE SNF canister.

Table 6-6 gives the reactivity of the WP assuming that the clad, the stainless steel pipe, and the basket support brackets are degraded. The remains of the fuel rod (fuel, graphite reflector, and Zr rod for the first four cases) are settled at the bottom of the DOE SNF canister and surrounded by a mixture of degraded stainless steel and water (the percentage of dilution of the stainless steel varies).

Table 6-6. Results for the Configuration with the Basket Fully Degraded

File Name	k_{eff}	$k_{\text{eff}+2\sigma}$	AENCF (MeV)	H/X Atom Ratio	Description, % of Water in the Mixture of Goethite and Water, Mass of Gd (kg)
set4_1.O	0.8361	0.8390	0.0433	856	Zr rods intact, 78%, 8.9 (1-mm coat inside 45 tubes degraded).
set4_2.O	0.7814	0.7842	0.0467	136	Zr rods intact, 40%, 8.9 (1-mm coat inside 45 tubes degraded).
set4_3.O	0.8507	0.8537	0.0426	482	Zr rods intact, 78%, 7.1 (1-mm coat inside 36 tubes degraded).
st4_3a.O	0.9020	0.9050	0.0403	482	Zr rods intact, 78%, 3.6 (1-mm coat inside 18 tubes degraded).
set438.O	0.9010	0.9041	0.0402	396	Like st4_3a but water density is 0.8 g/cm ³ .
set435.O	0.8933	0.8960	0.0408	268	Like st4_3a but water density is 0.5 g/cm ³ .
set433.O	0.8809	0.8840	0.0424	182	Like st4_3a but water density is 0.3 g/cm ³ .
set4_4.O	1.1049	1.1078	0.0309	483	Zr rods intact, no coat, 78%, 0.
set4_5.O	0.7989	0.8015	0.0444	484	Zr rods are gone, 1-mm coat inside 45 tubes, 78%, 8.9.
set4_6.O	0.8199	0.8231	0.0430	485	Zr rods are gone, 78%, 7.1 (1-mm coat inside 36 tubes).
set4_7.O	1.0890	1.0920	0.0322	481	Advanced absorber matrix for 45 coated tubes degraded forms a layer on the bottom of the canister. The rods sit on this layer, 78%, 8.9.
set4_8.O	0.8311	0.8339	0.0426	481	Advanced absorber matrix between two rods, 78%, 1.5. See Figure 5-11.
set4_9.O	0.9220	0.9252	0.0388	481	0.1-mm coat of 111 tubes, 77%, 2.7.
set49a.O	0.9254	0.9284	0.0389	481	Like set4_9 but the four-cluster rods are used.

Table 6-6. Results for the Configuration with the Basket Fully Degraded (continued)

File Name	k_{eff}	$k_{\text{eff}+2\sigma}$	AENCF (MeV)	H/X Atom Ratio	Description, % of Water in the Mixture of Goethite and Water, Mass of Gd (kg)
set49b.O	0.9203	0.9232	0.0386	481	Like set4_9 but the density of graphite grade B (instead of graphite grade A) is used (Lynch 1975, p. 367 and Assumption 3.7).
set49c.O	0.8920	0.8945	0.0405	481	0.15 mm coat of 111 tubes, 77%, 4.1.
set49d.O	0.8701	0.8732	0.0412	481	0.2 mm coat of 111 tubes, 77%, 5.5.
set498.O	0.9174	0.9202	0.0394	396	Like set4_9 but water density is 0.8 g/cm ³ .
set495.O	0.9082	0.9112	0.0404	267	Like set4_9 but water density is 0.5 g/cm ³ .
set493.O	0.8979	0.9004	0.0414	182	Like set4_9 but water density is 0.3 g/cm ³ .

Table 6-7 presents the k_{eff} values for the following configuration: the partially fractured fuel has settled onto the bottom of the DOE SNF canister and is surrounded by goethite. The Zr and the graphite have settled onto the goethite layer.

Table 6-7. Results for the Configuration with the Fuel Partially Fractured

File Name	k_{eff}	$k_{\text{eff}+2\sigma}$	AENCF (MeV)	H/X Atom Ratio	Sphere Radius, Description
set5_1.O	0.6354	0.6373	0.0273	134	1 cm
set5_2.O	0.6585	0.6604	0.0257	134	0.5 cm
set5_3.O	0.6651	0.6670	0.0249	134	0.1 cm
set5_4.O	0.6632	0.6650	0.0248	134	0.1 cm, layers of graphite and Zr are neglected.
set5_5.O	0.6655	0.6673	0.0251	134	0.1 cm, layer of Zr has disappeared.
set5_6.O	0.6635	0.6652	0.0253	134	0.1 cm, layer of graphite has disappeared.

Table 6-8 presents the results for the configuration where the fuel elements and the basket are fully degraded.

Table 6-8. Results for the Configuration with the Fuel Element and the Basket Fully Degraded

File Name	k_{eff}	$k_{eff}+2\sigma$	AENCF (MeV)	H/X Atom Ratio	Description
set6_6.O	0.9060	0.9078	0.0194	114	The clay resulting from the degradation of the fuel elements and the basket is dry.
set6_7.O	0.9940	0.9958	0.0147	167	The clay resulting from the degradation of the fuel elements and the basket has 20% water.
set6_8.O	1.0682	1.0699	0.0108	253	The clay resulting from the degradation of the fuel elements and the basket has 40% water.
set6_9.O	1.1236	1.1250	0.0073	427	The clay resulting from the degradation of the fuel elements and the basket has 60% water.
st6_10.O	1.1272	1.1286	0.0061	565	The clay resulting from the degradation of the fuel elements and the basket has 68.41% water (tube full).
st6_11	0.1833	0.1836	0.0364	565	Like st6_10 but with 2.7 kg of Gd in the clay.
st6-12	0.5896	0.5907	0.0116	565	Like st6_10 but with 0.27 kg of Gd in the clay.
st6-13	0.8274	0.8288	0.0082	565	Like st6_10 but with 0.10 kg of Gd in the clay.

6.2.1.3 All WP Components Degrade

In this section, all the components in the WP are degraded (see Section 5.2.1.3). The volume of water in the clay varies. Results are listed in Table 6-9.

Table 6-9. Results for the Configuration with All the Internal Components of the WP Degraded

File Name	k_{eff}	$k_{eff}+2\sigma$	AENCF (MeV)	H/X Atom Ratio*	Description
set7_1.O	0.0721	0.0722	0.0245	633	The clay resulting from the degradation of all the Internal Components (IC) is dry.
set7_2.O	0.0521	0.0522	0.0203	2392	The clay resulting from the degradation of all the IC has 20% water.
set7_3.O	0.0420	0.0421	0.0145	5323	The clay resulting from the degradation of all the IC has 40% water.
set7_4.O	0.0384	0.0385	0.0119	7742	The clay resulting from the degradation of all the IC has 50.26% water.

* H/X atom ratio given in the Excel file named "alldc_EQ6.xls", spread sheet "all".

6.2.2 Waste Form Degrades After the Other Internal Components

Tables 6-10 through 6-13 present the results of the calculation described in Section 5.2.2.

6.2.2.1 DOE SNF Canister Intact

Table 6-10 presents the results for a configuration where the web-like structure, the SRS HLW glass, the SRS HLW glass pour canister, and the clad of the fuel element have degraded. The DOE SNF canister thickness is reduced to take into account the degradation of the canister shell (CRWMS M&O 1999f, p. 46). All the OIC are intact. The internal components of the DOE SNF canister are in the same configuration as in case set1_4 (see Table 6-2).

Table 6-10. Results for the Configuration with Clad, SRS HLW Glass, SRS HLW Glass Pour Canister, and Web-like Structure Degraded

File Name	k_{eff}	$k_{eff}+2\sigma$	AENCF (MeV)	H/X Atom Ratio*	Description
st11_2.O	0.8079	0.8095	0.0254	227	The clay resulting from the degradation of the HLW glass and the HLW glass pour canister is dry. The DOE SNF canister is on the bottom of the WP.
st11_4.O	0.8012	0.8030	0.0261	227	The clay resulting from the degradation of the HLW glass and the HLW glass pour canister has 20% water. The DOE SNF canister is on the bottom of the WP.
st11_5.O	0.7995	0.8014	0.0260	227	The clay resulting from the degradation of the HLW glass and the HLW glass pour canister has 40% water. The DOE SNF canister is in the middle of the WP.
st11_6.O	0.7984	0.8004	0.0263	227	The clay resulting from the degradation of the HLW glass and the HLW glass pour canister has 40% water. The DOE SNF canister is on the bottom of the WP.
st11_7.O	0.7995	0.8013	0.0262	227	The clay resulting from the degradation of the HLW glass and the HLW glass pour canister has 53.04% water. The DOE SNF canister is in the middle of the WP.
st11_8.O	0.7973	0.7996	0.0263	227	The clay resulting from the degradation of the HLW glass and the HLW glass pour canister has 53.04% water. The DOE SNF canister is on the bottom of the WP.

* See Table 6-2 case set1_4

Table 6-11 presents the k_{eff} values for the cases where DOE SNF canister is in the same configuration as in case set4_9 (see Table 6-6) and the component outside of the DOE SNF canister are fully degraded.

Table 6-11. Results for the Configuration with Clad, Basket, SRS HLW Glass, SRS HLW Glass Pour Canister, and Web-like Structure Degraded

File Name	k_{eff}	$k_{eff}+2\sigma$	AENCF (MeV)	H/X Atom Ratio*	Description
st12_1.O	0.9362	0.9394	0.0376	481	The clay resulting from the degradation of the SRS HLW glass and the SRS HLW glass pour canister is dry. The DOE SNF canister is on the bottom of the WP.
st121a.O	0.9067	0.9095	0.0388	481	Like st12_1 but with 4.1 kg of Gd in the DOE SNF canister.
st12_2.O	0.9272	0.9297	0.0385	481	The clay resulting from the degradation of the SRS HLW glass and the SRS HLW glass pour canister has 20% water. The DOE SNF canister is on the bottom of the WP.
st12_3.O	0.9198	0.9229	0.0387	481	The clay resulting from the degradation of the SRS HLW glass and the SRS HLW glass pour canister has 40% water. The DOE SNF canister is on the bottom of the WP.
st12_4.O	0.9219	0.9247	0.0385	481	The clay resulting from the degradation of the SRS HLW glass and the SRS HLW glass pour canister has 53.04% water. The DOE SNF canister is on the bottom of the WP.
* See Table 6-6 case set4_9					

Table 6-12 lists the results for the configuration where all the internal components of the WP are degraded but the DOE SNF canister is intact. The internal components of the DOE SNF canister are in the same configuration as in case st6_13 (see Table 6-8).

Table 6-12. Results for the Configuration where All the Internal Components are Degraded Excluding the DOE SNF Canister

File Name	k_{eff}	k_{eff+2}	AENCF (MeV)	H/X Atom Ratio*	Description
st13_1.O	0.8322	0.8338	0.0079	565	The clay resulting from the degradation of the SRS HLW glass and the SRS HLW glass pour canister is dry. The DOE SNF canister is on the bottom of the WP.
st13_2.O	0.8207	0.8226	0.0078	565	The clay resulting from the degradation of the SRS HLW glass and the SRS HLW glass pour canister has 20% water. The DOE SNF canister is on the bottom of the WP.
st13_3.O	0.8185	0.8203	0.0081	565	The clay resulting from the degradation of the SRS HLW glass and the SRS HLW glass pour canister has 40% water. The DOE SNF canister is on the bottom of the WP.
st13_4.O	0.8161	0.8179	0.0078	565	The clay resulting from the degradation of the SRS HLW glass and the SRS HLW glass pour canister has 53.04% water. The DOE SNF canister is on the bottom of the WP.
* See Table 6-8 case st6-13.					

6.2.2.2 Waste Form Intact, Other Internal Components Degraded

Table 6-13 presents the results of the calculation described in Section 5.2.2.2.

Table 6-13. Results for the Configuration with the WF Intact and the OIC of the WP Degraded

File Name	k_{eff}	$k_{\text{eff}}+2\sigma$	AENCF (MeV)	Description
set8_2.0	1.0184	1.0202	0.0355	Fuel is intact, and stacked on the bottom of the WP. OIC of the WP are degraded. Clay has 0% water. 2.7 kg of Gd is in the clay.
set8_3.0	1.0143	1.0160	0.0344	Fuel is intact, and stacked on the bottom of the WP. OIC of the WP are degraded. Clay has 20% water. 2.7 kg of Gd is in the clay.
set8_4.0	1.0267	1.0286	0.0331	Fuel is intact, and stacked on the bottom of the WP. OIC of the WP are degraded. Clay has 40% water. 2.7 kg of Gd is in the clay.
set8_5.0	1.0360	1.0378	0.0327	Fuel is intact, and stacked on the bottom of the WP. OIC of the WP are degraded. Clay has 50.5% water. 2.7 kg of Gd is in the clay.
set8_6.0	0.9409	0.9427	0.0385	Fuel is intact, and stacked on the bottom of the WP. OIC of the WP are degraded. Clay has 0% water. 2.7 kg of Gd is in a layer of clay at the bottom of the WP.
set86a.0	0.9129	0.9146	0.0394	Like set8_6 but 4.1 kg of Gd is in a layer of clay at the bottom of the WP.
set8_7.0	0.9222	0.9241	0.0383	Fuel is intact, and stacked on the bottom of the WP. OIC of the WP are degraded. Clay has 20% water. 2.7 kg of Gd is in a layer of clay at the bottom of the WP.
set8_8.0	0.9121	0.9138	0.0378	Fuel is intact, and stacked on the bottom of the WP. OIC of the WP are degraded. Clay has 40% water. 2.7 kg of Gd is in a layer of clay at the bottom of the WP.
set8_9.0	0.9092	0.9110	0.0377	Fuel is intact, and stacked on the bottom of the WP. OIC of the WP are degraded. Clay has 50.5% water. 2.7 kg of Gd is in a layer of clay at the bottom of the WP.
st8_10.0	0.9340	0.9357	0.0387	Fuel is intact, and stacked on the bottom of the WP. OIC of the WP are degraded. Clay with 0% water. 2.7 kg of Gd is in cylinder (Radius=24 cm) centered at the bottom of the WP.
st8_11.0	0.9135	0.9152	0.0385	Fuel is intact, and stacked on the bottom of the WP. OIC of the WP are degraded. Clay with 20% water. 2.7 kg of Gd is in cylinder (Radius=24 cm) centered at the bottom of the WP.
st8_12.0	0.9039	0.9056	0.0383	Fuel is intact, and stacked on the bottom of the WP. OIC of the WP are degraded. Clay with 40% water. 2.7 kg of Gd is in cylinder (Radius=24 cm) centered at the bottom of the WP.
st8_13.0	0.8993	0.9011	0.0380	Fuel is intact, and stacked on the bottom of the WP. OIC of the WP are degraded. Clay with 50.5% water. 2.7 kg of Gd is in cylinder (Radius=24 cm) centered at the bottom of the WP.

Table 6-13. Results for the Configuration with the WF Intact and the OIC of the WP Degraded (continued)

File Name	k_{eff}	$k_{eff}+2\sigma$	AENCF (MeV)	Description
set8_1.O	0.6343	0.6359	0.0423	Fuel has degraded and is confined at the bottom of the WP.
st8_14.O	0.0146	0.0146	0.0037	Layer of fuel and 40% of the clay with 50.55% of the water and 2.7 kg of Gd at the bottom of the WP. Layer of clay with 50.55% of water fills the WP. H/X=13.65.
st8_15.O	0.0128	0.0128	0.0047	Layer of fuel and 60% of the clay with 50.55% of the water and 2.7 kg of Gd at the bottom of the WP. Layer of clay with 50.55% of water fills the WP. H/X=20.34.
st8_16.O	0.0128	0.0128	0.0034	Like st8_15 with 4.1 kg of Gd in the clay + fuel + water mix.
st8_17.O	0.0127	0.0128	0.0058	Like st8_15 with 5.5 kg of Gd in the clay + fuel + water mix.
Note: H/X in a fuel pin = 0.612 for all cases unless otherwise specified				

6.2.3 Intermediate Degraded Configuration

Results of the calculation described in Section 5.2.3 are given in Table 6-14. In the configuration considered, most of the glass remains intact and some portion of the fuel rods is degraded.

Table 6-14. Results for the Configuration where Some Portion of the Fuel Rods is Degraded while the SRS HLW Glass is Intact

File Name	k_{eff}	$k_{\text{eff}}+2\sigma$	AENCF (MeV)	H/X Atom Ratio in the Slurry	Description
st14_1.O	0.7117	0.7133	0.0413	49	0% of the slurry volume is water. The rods are stacked up in the bottom of the WP. The remaining Gd is in the clay.
st14_2.O	0.9578	0.9596	0.0204	11287	40% of the slurry volume is water. The rods are stacked up in the bottom of the WP. The remaining Gd is in the clay.
st14_3.O	0.9909	0.9927	0.0183	17893	51% of the slurry volume is water. The rods are stacked up in the bottom of the WP. The remaining Gd is in the clay.
st14_4.O	0.9959	0.9977	0.0193	17893	51% of the slurry volume is water. The rods are stacked up in the middle of the WP. The remaining Gd is in the clay.
st14_5.O	0.6877	0.6892	0.0286	17893	51% of the slurry volume is water. The rods are stacked up in the middle of the WP. The remaining Gd is located in a cylinder (Radius=24 cm) of clay located around the fuel rods.

7. ATTACHMENTS

Attachments to this calculation are listed in Table 7-1 below.

Table 7-1. List of Attachments

Attachment Number	Description	Pages
I	MCNP Input Files (hard copy listing of the content of the directory "INPUT" on the CD).	4
II	MCNP Output Files (hard copy listing of the content of the directory "OUTPUT" on the CD).	4
III	Hard copy listing of the Electronic Media (Compact Disc), CRWMS M&O (1999a).	1
VI	Sketches: 5 DHLW/DOE Spent Fuel Disposal Container (SK-0069 REV 01) TRIGA DOE SNF Basket Assembly (SK-0124 REV 00).	2
V	Document Input Reference Sheets.	7

Title: TRIGA Fuel Phase I and II Criticality Calculation

Document Identifier: CAL-MGR-NU-000001 REV 00 Attachment I, Page I-1 of I-4

List of all the files in the directory /Rev00b/INPUT on the electronic media (CRWMS M&O 1999a).

Table I-1. List of the files in the subdirectory table6-1

File Name	File Size (bytes)	Date Last Accessed	Time Last Accessed
4rod6	13,514	08/11/99	10:08a
indry	13,176	08/11/99	10:08a
int12a	14,363	08/11/99	10:08a
inta12	14,357	08/11/99	10:08a
intact	13,488	08/11/99	10:08a
intaFL	13,480	08/11/99	10:08a
intaou	13,669	08/11/99	10:08a
int_03	13,481	08/11/99	10:08a
int_05	13,481	08/11/99	10:08a
int_08	13,484	08/11/99	10:08a
int_1	13,431	08/11/99	10:08a
int_2	13,513	08/11/99	10:08a

Table I-2. List of the files in the subdirectory table6-2

File Name	File Size (bytes)	Date Last Accessed	Time Last Accessed
set103	12,965	08/11/1999	10:08a
set105	12,965	08/11/1999	10:08a
set108	12,965	08/11/1999	10:08a
set1_1	12,966	08/11/1999	10:08a
set1_2	15,371	08/11/1999	10:08a
set1_3	15,375	08/11/1999	10:08a
set1_4	12,963	08/11/1999	10:08a
set1_5	13,002	08/11/1999	10:08a
set1_6	12,964	08/11/1999	10:08a
set1_7	12,963	08/11/1999	10:08a
set1_8	12,768	08/11/1999	10:08a

Table I-3. List of the files in the subdirectory table6-3

File Name	File Size (bytes)	Date Last Accessed	Time Last Accessed
set2_1	12,755	08/11/1999	10:08a
set2_2	12,742	08/11/1999	10:08a
set2_3	12,735	08/11/1999	10:08a

Table I-4. List of the files in the subdirectory table6-4

File Name	File Size (bytes)	Date Last Accessed	Time Last Accessed
set3_1	12,794	08/11/1999	10:08a
set3_2	12,798	08/11/1999	10:08a

Title: TRIGA Fuel Phase I and II Criticality Calculation

Document Identifier: CAL-MGR-NU-000001 REV 00 Attachment I, Page I-2 of I-4

Table I-5. List of the files in the subdirectory table6-5

File Name	File Size (bytes)	Date Last Accessed	Time Last Accessed
set6_1	12,449	08/11/1999	10:08a
set6_2	12,447	08/11/1999	10:08a
set6_3	12,446	08/11/1999	10:08a
set6_4	12,446	08/11/1999	10:08a
set6_5	12,451	08/11/1999	10:08a

Table I-6. List of the files in the subdirectory table6-6

File Name	File Size (bytes)	Date Last Accessed	Time Last Accessed
set433	12,479	08/11/1999	10:08a
set435	12,479	08/11/1999	10:08a
set438	12,479	08/11/1999	10:08a
set493	12,492	08/11/1999	10:08a
set495	12,492	08/11/1999	10:08a
set498	12,492	08/11/1999	10:08a
set49a	12,488	08/11/1999	10:08a
set49b	12,488	08/11/1999	10:08a
set49c	12,488	08/11/1999	10:08a
set49d	12,488	08/11/1999	10:08a
set4_1	12,476	08/11/1999	10:08a
set4_2	12,614	08/11/1999	10:08a
set4_3	12,476	08/11/1999	10:08a
set4_4	12,477	08/11/1999	10:08a
set4_5	12,476	08/11/1999	10:08a
set4_6	12,476	08/11/1999	10:08a
set4_7	12,555	08/11/1999	10:08a
set4_8	12,966	08/11/1999	10:08a
set4_9	12,488	08/11/1999	10:08a
st4_3a	12,476	08/11/1999	10:08a

Table I-7. List of the files in the subdirectory table6-7

File Name	File Size (bytes)	Date Last Accessed	Time Last Accessed
set5_1	10,249	08/11/1999	10:08a
set5_2	10,257	08/11/1999	10:08a
set5_3	10,257	08/11/1999	10:08a
set5_4	10,261	08/11/1999	10:08a
set5_5	10,243	08/11/1999	10:08a
set5_6	10,261	08/11/1999	10:08a

Title: TRIGA Fuel Phase I and II Criticality Calculation

Document Identifier: CAL-MGR-NU-000001 REV 00 Attachment I, Page I-3 of I-4

Table I-8. List of the files in the subdirectory table6-8

File Name	File Size (bytes)	Date Last Accessed	Time Last Accessed
set6_6	11,006	08/11/1999	10:08a
set6_7	11,003	08/11/1999	10:08a
set6_8	11,003	08/11/1999	10:08a
set6_9	11,003	08/11/1999	10:08a
st6_10	11,000	08/11/1999	10:08a
st6_11	11,030	08/11/1999	10:08a
st6_12	11,030	08/11/1999	10:08a
st6_13	11,030	08/11/1999	10:08a

Table I-9. List of the files in the subdirectory table6-9

File Name	File Size (bytes)	Date Last Accessed	Time Last Accessed
set7_1	4,037	08/11/1999	10:08a
set7_2	3,872	08/11/1999	10:08a
set7_3	3,607	08/11/1999	10:08a
set7_4	4,202	08/11/1999	10:08a

Table I-10. List of the files in the subdirectory table6-10

File Name	File Size (bytes)	Date Last Accessed	Time Last Accessed
st11_2	9,555	08/11/1999	10:08a
st11_4	9,558	08/11/1999	10:08a
st11_5	9,364	08/11/1999	10:08a
st11_6	9,461	08/11/1999	10:08a
st11_7	9,357	08/11/1999	10:08a
st11_8	9,451	08/11/1999	10:08a

Table I-11. List of the files in the subdirectory table6-11

File Name	File Size (bytes)	Date Last Accessed	Time Last Accessed
st121a	9,331	08/11/1999	10:08a
st12_1	9,331	08/11/1999	10:08a
st12_2	9,351	08/11/1999	10:08a
st12_3	9,351	08/11/1999	10:08a
st12_4	9,363	08/11/1999	10:08a

Table I-12. List of the files in the subdirectory table6-12

File Name	File Size (bytes)	Date Last Accessed	Time Last Accessed
st13_1	7,859	08/11/1999	10:08a
st13_2	7,870	08/11/1999	10:08a
st13_3	7,839	08/11/1999	10:08a
st13_4	7,837	08/11/1999	10:08a

Title: TRIGA Fuel Phase I and II Criticality Calculation

Document Identifier: CAL-MGR-NU-000001 REV 00 **Attachment I, Page I-4 of I-4**

Table I-13. List of the files in the subdirectory table6-13

File Name	File Size (bytes)	Date Last Accessed	Time Last Accessed
set86a	7,754	08/11/1999	10:08a
set8_1	4,287	08/11/1999	10:08a
set8_2	6,493	08/11/1999	10:08a
set8_3	6,748	08/11/1999	10:08a
set8_4	6,749	08/11/1999	10:08a
set8_5	6,826	08/11/1999	10:08a
set8_6	7,760	08/11/1999	10:08a
set8_7	8,278	08/11/1999	10:08a
set8_8	8,282	08/11/1999	10:08a
set8_9	8,448	08/11/1999	10:08a
st8_10	7,773	08/11/1999	10:08a
st8_11	8,284	08/11/1999	10:08a
st8_12	8,289	08/11/1999	10:08a
st8_13	8,459	08/11/1999	10:08a
st8_14	4,617	08/11/1999	10:08a
st8_15	4,740	08/11/1999	10:08a
st8_16	4,740	08/11/1999	10:08a
st8_17	4,740	08/11/1999	10:08a

Table I-14. List of the files in the subdirectory table6-14

File Name	File Size (bytes)	Date Last Accessed	Time Last Accessed
st14_1	8,186	08/11/1999	10:08a
st14_2	8,198	08/11/1999	10:08a
st14_3	8,118	08/11/1999	10:08a
st14_4	8,220	08/11/1999	10:08a
st14_5	9,128	08/11/1999	10:08a

Title: TRIGA Fuel Phase I and II Criticality Calculation

Document Identifier: CAL-MGR-NU-000001 REV 00 **Attachment II, Page II-1 of II-4**

List of all the files in the directory Rev00b/OUTPUT on the electronic media (CRWMS M&O 1999a)

Table II-1. List of the files in the subdirectory table6-1

File Name	File Size (bytes)	Date Last Accessed	Time Last Accessed
4rod6.O	430,472	08/11/1999	10:09a
indry.O	490,536	08/11/1999	10:09a
int12a.O	514,299	08/11/1999	10:09a
inta12.O	513,147	08/11/1999	10:09a
intact.O	493,395	08/11/1999	10:09a
intaFL.O	390,296	08/11/1999	10:09a
intaou.O	500,754	08/11/1999	10:09a
int_03.O	493,859	08/11/1999	10:09a
int_05.O	493,957	08/11/1999	10:09a
int_08.O	494,322	08/11/1999	10:09a
int_1.O	486,272	08/11/1999	10:09a
int_2.O	494,020	08/11/1999	10:09a

Table II-2. List of the files in the subdirectory table6-2

File Name	File Size (bytes)	Date Last Accessed	Time Last Accessed
set103.O	374,262	08/11/1999	10:11a
set105.O	374,115	08/11/1999	10:11a
set108.O	374,262	08/11/1999	10:11a
set1_1.O	375,273	08/11/1999	10:11a
set1_2.O	470,807	08/11/1999	10:11a
set1_3.O	470,936	08/11/1999	10:11a
set1_4.O	374,325	08/11/1999	10:11a
set1_5.O	377,096	08/11/1999	10:11a
set1_6.O	375,207	08/11/1999	10:11a
set1_7.O	375,460	08/11/1999	10:11a
set1_8.O	372,484	08/11/1999	10:11a

Table II-3. List of the files in the subdirectory table6-3

File Name	File Size (bytes)	Date Last Accessed	Time Last Accessed
set2_1.O	436,927	08/11/1999	10:11a
set2_2.O	435,647	08/11/1999	10:11a
set2_3.O	434,365	08/11/1999	10:11a

Table II-4. List of the files in the subdirectory table6-4

File Name	File Size (bytes)	Date Last Accessed	Time Last Accessed
set3_1.O	407,086	08/11/1999	10:11a
set3_2.O	408,129	08/11/1999	10:11a

Title: TRIGA Fuel Phase I and II Criticality Calculation

Document Identifier: CAL-MGR-NU-000001 REV 00 Attachment II, Page II-2 of II-4

Table II-5. List of the files in the subdirectory table6-5

File Name	File Size (bytes)	Date Last Accessed	Time Last Accessed
set6_1.O	442,979	08/11/1999	10:11a
set6_2.O	443,171	08/11/1999	10:11a
set6_3.O	442,154	08/11/1999	10:12a
set6_4.O	443,234	08/11/1999	10:12a
set6_5.O	439,078	08/11/1999	10:12a

Table II-6. List of the files in the subdirectory table6-6

File Name	File Size (bytes)	Date Last Accessed	Time Last Accessed
set433.O	369,569	08/11/1999	10:12a
set435.O	369,129	08/11/1999	10:12a
set438.O	369,242	08/11/1999	10:12a
set493.O	369,990	08/11/1999	10:12a
set495.O	369,672	08/11/1999	10:12a
set498.O	369,751	08/11/1999	10:12a
set49a.O	368,650	08/11/1999	10:12a
set49b.O	369,848	08/11/1999	10:12a
set49c.O	370,188	08/11/1999	10:12a
set49d.O	370,012	08/11/1999	10:12a
set4_1.O	369,402	08/11/1999	10:12a
set4_2.O	371,999	08/11/1999	10:12a
set4_3.O	369,402	08/11/1999	10:12a
set4_4.O	369,030	08/11/1999	10:12a
set4_5.O	368,709	08/11/1999	10:12a
set4_6.O	369,873	08/11/1999	10:12a
set4_7.O	371,727	08/11/1999	10:12a
set4_8.O	404,057	08/11/1999	10:12a
set4_9.O	369,848	08/11/1999	10:12a
st4_3a.O	369,305	08/11/1999	10:12a

Table II-7. List of the files in the subdirectory table6-7

File Name	File Size (bytes)	Date Last Accessed	Time Last Accessed
set5_1.O	366,268	08/11/1999	10:12a
set5_2.O	366,268	08/11/1999	10:12a
set5_3.O	367,440	08/11/1999	10:12a
set5_4.O	364,800	08/11/1999	10:12a
set5_5.O	366,454	08/11/1999	10:12a
set5_6.O	366,290	08/11/1999	10:12a

Title: TRIGA Fuel Phase I and II Criticality Calculation

Document Identifier: CAL-MGR-NU-000001 REV 00 Attachment II, Page II-3 of II-4

Table II-8. List of the files in the subdirectory table6-8

File Name	File Size (bytes)	Date Last Accessed	Time Last Accessed
set6_6.O	381,806	08/11/1999	10:12a
set6_7.O	381,051	08/11/1999	10:12a
set6_8.O	382,023	08/11/1999	10:12a
set6_9.O	381,813	08/11/1999	10:12a
st6_10.O	380,871	08/11/1999	10:12a
st6_11.O	381,182	08/11/1999	10:12a
st6_12.O	381,500	08/11/1999	10:12a
st6_13.O	381,500	08/11/1999	10:12a

Table II-9. List of the files in the subdirectory table6-9

File Name	File Size (bytes)	Date Last Accessed	Time Last Accessed
set7_1.O	325,746	08/11/1999	10:12a
set7_2.O	323,358	08/11/1999	10:12a
set7_3.O	324,797	08/11/1999	10:12a
set7_4.O	323,653	08/11/1999	10:12a

Table II-10. List of the files in the subdirectory table6-10

File Name	File Size (bytes)	Date Last Accessed	Time Last Accessed
st11_2.O	461,121	08/11/1999	10:09a
st11_4.O	459,890	08/11/1999	10:09a
st11_5.O	460,892	08/11/1999	10:09a
st11_6.O	122,880	08/11/1999	10:10a
st11_7.O	458,897	08/11/1999	10:10a
st11_8.O	389,995	08/11/1999	10:10a

Table II-11. List of the files in the subdirectory table6-11

File Name	File Size (bytes)	Date Last Accessed	Time Last Accessed
st121a.O	346,049	08/11/1999	10:10a
st12_1.O	346,000	08/11/1999	10:10a
st12_2.O	346,327	08/11/1999	10:10a
st12_3.O	345,820	08/11/1999	10:10a
st12_4.O	348,755	08/11/1999	10:10a

Table II-12. List of the files in the subdirectory table6-12

File Name	File Size (bytes)	Date Last Accessed	Time Last Accessed
st13_1.O	258,325	08/11/1999	10:10a
st13_2.O	257,536	08/11/1999	10:10a
st13_3.O	258,883	08/11/1999	10:10a
st13_4.O	257,835	08/11/1999	10:10a

Title: TRIGA Fuel Phase I and II Criticality Calculation

Document Identifier: CAL-MGR-NU-000001 REV 00 Attachment II, Page II-4 of II-4

Table II-13. List of the files in the subdirectory table6-13

File Name	File Size (bytes)	Date Last Accessed	Time Last Accessed
set86a.O	450,403	08/11/1999	10:10a
set8_1.O	363,924	08/11/1999	10:10a
set8_2.O	442,426	08/11/1999	10:10a
set8_3.O	442,674	08/11/1999	10:10a
set8_4.O	442,856	08/11/1999	10:11a
set8_5.O	442,407	08/11/1999	10:11a
set8_6.O	450,401	08/11/1999	10:11a
set8_7.O	450,554	08/11/1999	10:11a
set8_8.O	450,469	08/11/1999	10:11a
set8_9.O	448,379	08/11/1999	10:11a
st8_10.O	449,467	08/11/1999	10:11a
st8_11.O	449,779	08/11/1999	10:11a
st8_12.O	449,778	08/11/1999	10:11a
st8_13.O	448,902	08/11/1999	10:11a
st8_14.O	372,014	08/11/1999	10:11a
st8_15.O	371,671	08/11/1999	10:11a
st8_16.O	369,847	08/11/1999	10:11a
st8_17.O	369,847	08/11/1999	10:11a

Table II-14. List of the files in the subdirectory table6-14

File Name	File Size (bytes)	Date Last Accessed	Time Last Accessed
st14_1.O	536,037	08/11/1999	10:11a
st14_2.O	536,755	08/11/1999	10:11a
st14_3.O	536,403	08/11/1999	10:11a
st14_4.O	532,329	08/11/1999	10:11a
st14_5.O	534,606	08/11/1999	10:11a

Title: TRIGA Fuel Phase I and II Criticality Calculation

Document Identifier: CAL-MGR-NU-000001 REV 00 Attachment III, Page III-1 of III-1

Tables III-1 and III-2 provide the list of directories and files on the electronic media (CRWMS M&O 1999a).

Table III-1. The Directories and Files on the Electronic Media in the Directory Rev00b

File Name	Size (bytes)	Date Last Accessed	Time Last Accessed
INPUT	Directory*	08/11/1999	10:32a
OUTPUT	Directory**	08/11/1999	10:32a
res.xls	47,616	08/11/1999	9:54a
gd compo.xls	30,720	08/11/1999	9:54a
allde_EQ6.xls	111,616	08/10/1999	5:36p
05-24-99.xls	234,496	08/17/1999	2:26p
EQ6 runs.xls	452,608	07/19/1999	8:28a
* See Attachment I			
** See Attachment II			

Table III-2. The Directories and Files on the Electronic Media in the Directory Rev00a/Disc

File Name	Size (bytes)	Date Last Accessed	Time Last Accessed
05-24-99.xls	231,424	07/15/1999	4:51p
allde_EQ6.xls	110,592	07/15/1999	4:51p
AP3-12.doc	2,866,176	07/19/1999	9:46a
attachment1.doc	62,464	07/19/1999	9:44a
attachment2.doc	50,176	07/19/1999	9:45a
attachment3.doc	57,344	07/19/1999	10:11a
attachment4.doc	337,920	07/19/1999	9:45a
EQ6 run.xls	452,608	07/19/1999	8:28a
gd comp.xls	25,088	07/07/1999	1:21p
INPUT	Directory	08/25/1999	3:02p
OUTPUT	Directory	08/25/1999	3:02p

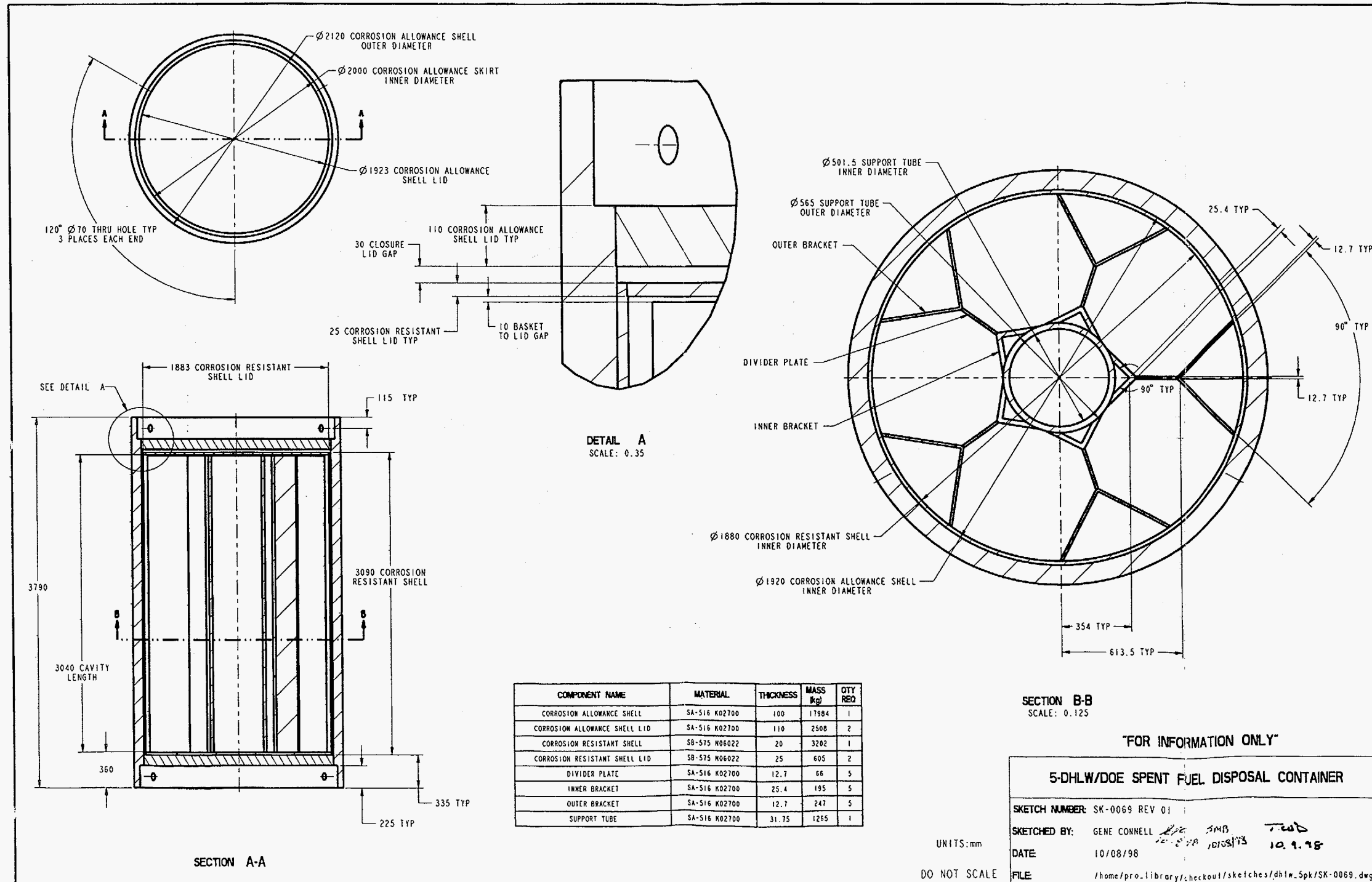

COMPONENT NAME	MATERIAL	THICKNESS	MASS (kg)	QTY REQ
CORROSION ALLOWANCE SHELL	SA-516 K02700	100	17984	1
CORROSION ALLOWANCE SHELL LID	SA-516 K02700	110	2508	2
CORROSION RESISTANT SHELL	S8-575 N06022	20	3292	1
CORROSION RESISTANT SHELL LID	S8-575 N06022	25	605	2
DIVIDER PLATE	SA-516 K02700	12.7	66	5
INNER BRACKET	SA-516 K02700	25.4	195	5
OUTER BRACKET	SA-516 K02700	12.7	247	5
SUPPORT TUBE	SA-516 K02700	31.75	1255	1

SECTION B-B
 SCALE: 0.125

"FOR INFORMATION ONLY"

5-DHLW/DOE SPENT FUEL DISPOSAL CONTAINER

SKETCH NUMBER: SK-0069 REV 01
 SKETCHED BY: GENE CONNELL *Gene Connell* *10/08/98*
 DATE: 10/08/98
 FILE: /home/pro.library/checkout/sketches/dhlw_5pk/SK-0069.dwg

UNITS: mm
 DO NOT SCALE

SECTION A-A

DETAIL A
 SCALE: 0.35

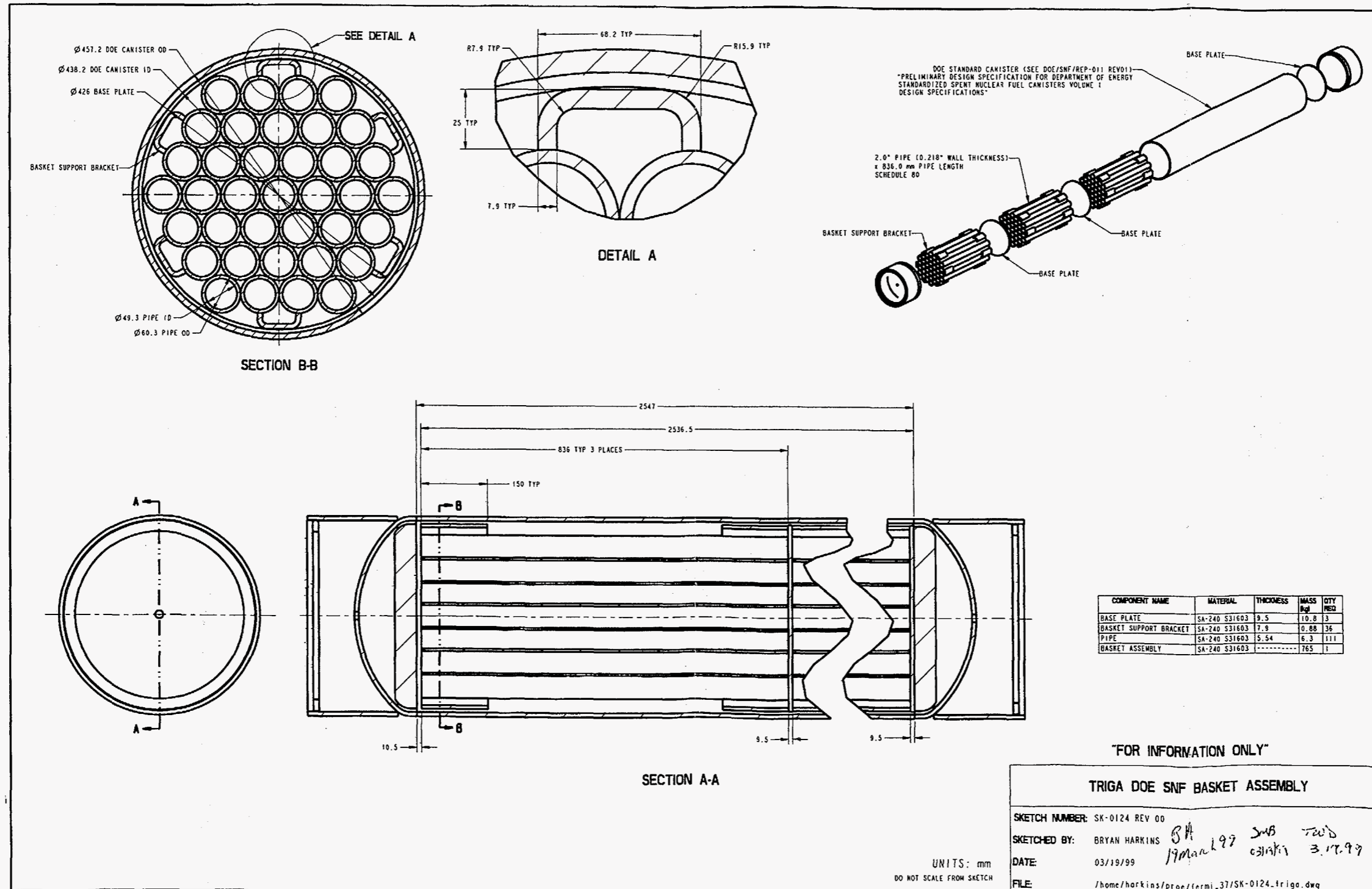

**OFFICE OF CIVILIAN RADIOACTIVE WASTE MANAGEMENT
DOCUMENT INPUT REFERENCE SHEET**

1. Document Identifier No./Rev.:		Change:	Title:						
CAL-MGR-NU-000001 REV 00		N/A	TRIGA Fuel Phase I and II Criticality Calculation						
Input Document			4. Input Status	5. Section Used in	6. Input Description	7. TBV/TBD Priority	8. TBV Due To		
2. Technical Product Input Source Title and Identifier(s) with Version		3. Section					Unqual.	From Uncontrolled Source	Un-confirmed
2a	CRC Press 1985. <i>CRC Handbook of Chemistry and Physics, 66th Edition, 1985-1986.</i> Boca Raton, Florida: CRC Press, Inc. TIC: 216054.	p. B-160	N/A	5	Density of Zr.	N/A	N/A	N/A	N/A
1					This datum is taken from a standard handbook, and due to the nature of this source, this datum is an established fact and is, therefore, considered accepted.				
2	Beyer, W.H. 1987. <i>CRC Standard Mathematical Tables, 28th Edition.</i> Boca Raton, Florida: CRC Press, Inc. TIC: 240507.	p. 125	N/A	5	Formula of the Segment of a Circle. This formula is taken from a standard handbook, and due to the nature of this source, this datum is an established fact and is, therefore, considered accepted.	N/A	N/A	N/A	N/A
3	Benedict, M.; Pigford, T.H.; and Levi, H.W. 1981. <i>Nuclear Chemical Engineering, Second Edition.</i> New York, New York: McGraw-Hill Book Company. TIC: 245089.	p. 976	N/A	5	Atomic Weight of Pu-241. This datum is taken from a standard handbook, and due to the nature of this source, this datum is an established fact and is, therefore, considered accepted.	N/A	N/A	N/A	N/A

**OFFICE OF CIVILIAN RADIOACTIVE WASTE MANAGEMENT
DOCUMENT INPUT REFERENCE SHEET**

1. Document Identifier No./Rev.:		Change:	Title:						
CAL-MGR-NU-000001 REV 00		N/A	TRIGA Fuel Phase I and II Criticality Calculation						
Input Document		3. Section	4. Input Status	5. Section Used in	6. Input Description	7. TBV/TBD Priority	8. TBV Due To		
2. Technical Product Input Source Title and Identifier(s) with Version							Unqual.	From Uncontrolled Source	Un-confirmed
2a	CRWMS M&O 1998. <i>Software Qualification Report for MCNP Version 4B2, A General Monte Carlo N-Particle Transport Code.</i> CSCI: 30033 V4B2LV. 30033-2003 REV. 01. Las Vegas, Nevada: CRWMS M&O. ACC: MOL.19980622.0637.	Entire	N/A	Sect. 4, Att. I, Att. II	Software Qualification. Not an input, reference only.	N/A	N/A	N/A	N/A
4									
5	CRWMS M&O 1999d. <i>DOE SRS HLW Glass Chemical Composition.</i> BBA000000-01717-0210-00038 REV 00. Las Vegas, Nevada: CRWMS M&O. ACC: MOL.19990215.0397.	Sect. 6	TBV-3022	5	Chemical Composition of the HLW Glass. This reference uses existing preliminary data from "Preliminary Waste Form Characteristics Report" ACC: MOL.19940726.0118	3	✓	N/A	N/A
6	CRWMS M&O 1999a. <i>Electronic Media (CD): TRIGA Fuel Phase I and II Criticality Calculation, CAL-MGR-NU-000001 REV 00.</i> Las Vegas, Nevada: CRWMS M&O. ACC: MOL.19990902.0464	Entire	N/A	Sect. 5 and 6	Calculation output files supporting the document CAL-MGR-NU-000001 REV 00. Not an input, reference only.	N/A	N/A	N/A	N/A

**OFFICE OF CIVILIAN RADIOACTIVE WASTE MANAGEMENT
DOCUMENT INPUT REFERENCE SHEET**

1. Document Identifier No./Rev.:		Change:	Title:						
CAL-MGR-NU-000001 REV 00		N/A	TRIGA Fuel Phase I and II Criticality Calculation						
Input Document			4. Input Status	5. Section Used in	6. Input Description	7. TBV/TBD Priority	8. TBV Due To		
2. Technical Product Input Source Title and Identifier(s) with Version		3. Section					Unqual.	From Uncontrolled Source	Un-confirmed
2a	CRWMS M&O 1999f. <i>EQ6 Calculations for Chemical Degradation of TRIGA Waste Packages</i> . CAL-EDC-MD-000001 REV 00. Las Vegas, Nevada: CRWMS M&O. ACC: MOL.19991118.0050 "INITAL USE"	Sect. 5	TBV-3147	5	Compositions of the Degraded Materials. Inputs used in this calculation are unqualified.	3	✓	N/A	N/A
7									
8	CRWMS M&O 1999e. <i>Generic Degradation Scenario and Configuration Analysis for DOE Codisposal Canister</i> . BBA000000-01717-0200-00071 REV 00. Las Vegas, Nevada: CRWMS M&O. ACC: MOL.19991118.0180	Sect. 6.2.2	N/A	5	Degradation Scenarios. Not an input, reference only.	N/A	N/A	N/A	N/A
9	CRWMS M&O 1999c. <i>Volume/Mass of DOE Canister and TRIGA SNF</i> . BBA000000-01717-0210-00046 REV 00. Las Vegas, Nevada: CRWMS M&O. ACC: MOL.19990713.0238. "INITAL USE"	Sect. 5 p. 7	TBV-3148	5	Mass of the Upper and Lower End Fittings. Inputs used in this calculation are unqualified.	3	✓	N/A	N/A

**OFFICE OF CIVILIAN RADIOACTIVE WASTE MANAGEMENT
DOCUMENT INPUT REFERENCE SHEET**

1. Document Identifier No./Rev.:		Change:	Title:						
CAL-MGR-NU-000001 REV 00		N/A	TRIGA Fuel Phase I and II Criticality Calculation						
Input Document		3. Section	4. Input Status	5. Section Used in	6. Input Description	7. TBV/TBD Priority	8. TBV Due To		
2. Technical Product Input Source Title and Identifier(s) with Version							Unqual.	From Uncontrolled Source	Un-confirmed
2a	CRWMS M&O 1999b. <i>Waste Package Materials Properties</i> . BBA000000-01717-0210-00017 REV 00. Las Vegas, Nevada: CRWMS M&O. ACC: MOL.19990407.0172. "INITAL USE"	Sect. 5	TBV-3149	5	Materials Composition. These data are accepted but need concurrence from the DOE AMOPE.	N/A	N/A	N/A	N/A
10									
11	DOE 1992. <i>Characteristics of Potential Repository Wastes</i> . Volume 1. DOE/RW-0184-R1. Washington, D.C.: U.S. Department of Energy, Office of Civilian Radioactive Waste Management. ACC: HQO.19920827.0001. "INITAL USE"	Sect. 3 pp. 3.3-4 through 3.3-6	TBV-3150	5	HLW Glass Canister Dimensions. This document has not been produced under the OCRWMS QA program.	3	✓	N/A	N/A
12	DOE 1998. <i>Preliminary Design Specification for Department of Energy Standardized Spent Nuclear Fuel Canisters, Volume 1 - Design Specification</i> . DOE/SNF/REP-011, Rev. 1. Washington, D.C.: U.S. Department of Energy, Office of Civilian Radioactive Waste Management. TIC: 241528. "INITAL USE"	Appendix A	TBV-3151	5	DOE SNF Canister Dimensions. This document has not been produced under the OCRWMS QA program.	3	✓	N/A	N/A

**OFFICE OF CIVILIAN RADIOACTIVE WASTE MANAGEMENT
DOCUMENT INPUT REFERENCE SHEET**

1. Document Identifier No./Rev.:		Change:	Title:						
CAL-MGR-NU-000001 REV 00		N/A	TRIGA Fuel Phase I and II Criticality Calculation						
Input Document			4. Input Status	5. Section Used in	6. Input Description	7. TBV/TBD Priority	8. TBV Due To		
2. Technical Product Input Source Title and Identifier(s) with Version		3. Section					Unqual.	From Uncontrolled Source	Un-confirmed
2a 13	Briesmeister, J.F., ed. 1997. <i>MCNP - A General Monte Carlo N-Particle Transport Code</i> . LA-12625-M, Version 4B. Los Alamos, New Mexico: Los Alamos National Laboratory. TIC: 241044.	Entire	N/A	5	MCNP Manual. This is not an input, it is a reference.	N/A	N/A	N/A	N/A
14	Lynch, C.T., ed. 1975. <i>CRC Handbook of Materials Science, Volume Three: Nonmetallic Materials and Applications</i> . Cleveland, Ohio: CRC Press, Inc. TIC: 240575.	Table 3.6-6 p. 367	N/A	5	Density of Graphite. This datum is taken from a standard handbook, and due to the nature of this source, this datum is an established fact and is, therefore, considered accepted.	N/A	N/A	N/A	N/A

**OFFICE OF CIVILIAN RADIOACTIVE WASTE MANAGEMENT
DOCUMENT INPUT REFERENCE SHEET**

1. Document Identifier No./Rev.:		Change:	Title:						
CAL-MGR-NU-000001 REV 00		N/A	TRIGA Fuel Phase I and II Criticality Calculation						
Input Document		3. Section	4. Input Status	5. Section Used in	6. Input Description	7. TBV/TBD Priority	8. TBV Due To		
2. Technical Product Input Source Title and Identifier(s) with Version							Unqual.	From Uncontrolled Source	Un-confirmed
2a	Parrington, J.R.; Knox, H.D.; Breneman, S.L.; Baum, E.M.; and Feiner, F. 1996. <i>Nuclides and Isotopes, Fifteenth Edition</i> . San Jose, California: General Electric Company. TIC: 233705.	Entire	N/A	5	Atomic Weight of the Elements/Isotopes Used in this Calculation (except Pu-241). Data in this reference are taken from standard handbooks, and due to the nature of this source, these data are established facts and are, therefore, considered accepted.	N/A	N/A	N/A	N/A
15									
16	Stout, R.B. and Leider, H.R., eds. 1991. <i>Preliminary Waste Form Characteristics Report</i> . Version 1.0. Livermore, California: Lawrence Livermore National Laboratory. ACC: MOL.19940726.0118.	Sect. 2, p. 2.2.1.1- 4	TBV- 3022	5	Density of the HLW Glass. This document has not been produced under the OCRWMS QA program.	3	✓	N/A	N/A

**OFFICE OF CIVILIAN RADIOACTIVE WASTE MANAGEMENT
DOCUMENT INPUT REFERENCE SHEET**

1. Document Identifier No./Rev.:		Change:	Title:						
CAL-MGR-NU-000001 REV 00		N/A	TRIGA Fuel Phase I and II Criticality Calculation						
Input Document			4. Input Status	5. Section Used in	6. Input Description	7. TBV/TBD Priority	8. TBV Due To		
2. Technical Product Input Source Title and Identifier(s) with Version		3. Section					Unqual.	From Uncontrolled Source	Un-confirmed
2a	DOE 1999. <i>TRIGA (UZrH) Fuel Characteristics for Disposal Criticality Analysis.</i> DOE/SNF/REP-048, Rev. 0. Washington, D.C.: U.S. Department of Energy, Office of Civilian Radioactive Waste Management. TIC: 244162.	Sect. 3	N/A	5	Fuel Rod Materials Composition, Fuel Rod Dimensions. This calculation is based in part on unqualified data such as DOE (1999). However, the unqualified data is only used to determine the bounding values and items that are important to safety for the fuel group that is identified by the National Spent Nuclear Fuel Program by establishing the limits based on the representative fuel type (TRIGA) for this group. Hence, the input values used for evaluation of codisposal viability of TRIGA SNF do not constitute data that have to be qualified prior to use of any results from this calculation for input into document supporting procurement, fabrication, or construction. They merely establish the bounds for acceptance. Since the input values are not relied upon directly to address safety and waste isolation issues, nor do the design inputs affect a system characteristic that is critical for satisfactory performance, data do not need to be controlled as TBV.	N/A	N/A	N/A	N/A
17									