

GA-A23277

REDUCTION OF CARBON INFLUX BY MINIMIZING TILE HEATING IN DIII-D

by
M.E. FRIEND, C.B. BAXI, M.A. MAHDAVI, and R.C. O'NEILL

This is a preprint of a paper to be presented at the 18th IEEE/NPSS Symposium on Fusion Engineering, October 25-29, 1999, in Albuquerque, New Mexico, and to be published in the *Proceedings*.

Work supported by
the U.S. Department of Energy
under Contract No. DE-AC03-99ER54463

GA PROJECT 30033
NOVEMBER 1999



DISCLAIMER

This report was prepared as an account of work sponsored by an agency of the United States Government. Neither the United States Government nor any agency thereof, nor any of their employees, make any warranty, express or implied, or assumes any legal liability or responsibility for the accuracy, completeness, or usefulness of any information, apparatus, product, or process disclosed, or represents that its use would not infringe privately owned rights. Reference herein to any specific commercial product, process, or service by trade name, trademark, manufacturer, or otherwise does not necessarily constitute or imply its endorsement, recommendation, or favoring by the United States Government or any agency thereof. The views and opinions of authors expressed herein do not necessarily state or reflect those of the United States Government or any agency thereof.

DISCLAIMER

Portions of this document may be illegible in electronic image products. Images are produced from the best available original document.

Reduction of Carbon Influx by Minimizing Tile Heating in DIII-D*

M.E. Friend, C.B. Baxi, M.A. Mahdavi, and R.C. O'Neill
 General Atomics, P.O. Box 85608, San Diego, California 92186-5608

Abstract

As predicted by theoretical models, under certain plasma configurations the edges of the graphite tiles lining the walls of the DIII-D vacuum vessel can exceed 2000°C. This is the temperature at which ablation occurs for the ATJ graphite material for localized heating (1500°C for the face of the tile) and thus represents an operational limit for the tokamak. This theoretical prediction is confirmed by observed increased carbon contamination in the plasma and wearing of the tile edges.

Several approaches were investigated to minimize tile edge heating by reducing the amount of heat flux on the tiles toroidal and poloidal surfaces. This was accomplished by modifying the geometry of the top two rows of the DIII-D centerpost tiles. For the toroidal surfaces, the geometry of the tile was changed from a faceted to a curved configuration, thereby reducing the angle of surface relative to the plasma field line. For the poloidal surfaces, it is predicted that the heat flux will be reduced by closing the gaps between the tiles. Both of these design changes will be implemented in the DIII-D tokamak during the Radiative Divertor Program (RDP) upgrade in the fall of 1999.

I. INTRODUCTION

The Radiative Divertor Program (RDP) is currently in the final stages of installation [1] (Fig. 1). The goal of this program is to study the reduction in peak heat flux with creation of a radiating zone in the divertor area formed by puffing neutral gas into the scrape off layer. This is accomplished in conjunction with particle control to limit the neutral gas from entering the plasma core. Particle control will be addressed in two ways; in the RDP baffle structures to limit the transport of gases from the divertor region to the core, and density control by a divertor cryopump at the inner and outer strike points of the divertor.

The RDP is designed for either single or double-null high triangularity plasma shape with a maximum plasma current of 3.0 MA. This baseline shape was chosen based on a systematic study of plasma shape and performance. The new divertor hardware enables continuing research towards this goal of DIII-D: integrated long pulse demonstration of well confined high-beta divertor plasma with non inductive current drive. The divertor hardware will provide the pumping and baffling required for the low density target plasmas of the advanced tokamak program, in addition to continuing the divertor research program [2].

Since the design effort on the RDP involved the creation of new and re-design of the plasma facing components, such

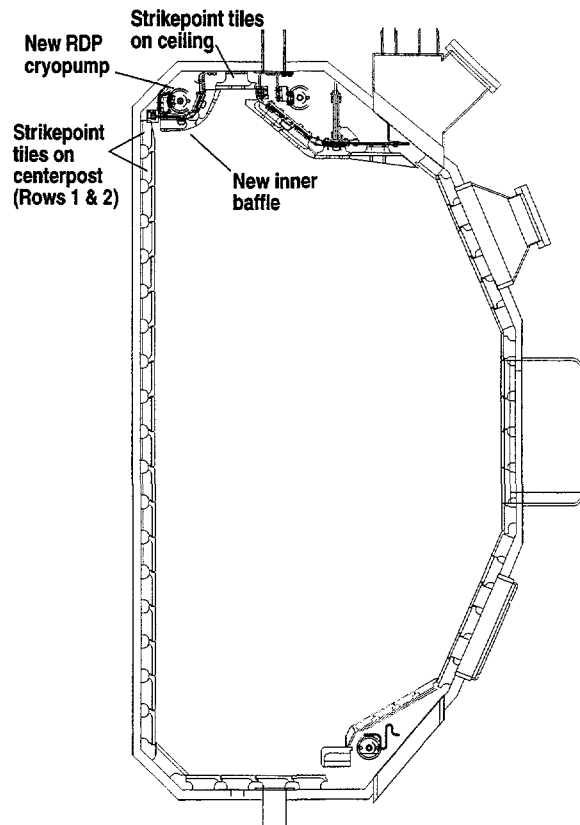

Fig. 1. Vertical cross section of DIII-D.

as the graphite tiles, the opportunity was taken to investigate possible improvements of their thermal operational characteristics. This was driven specifically by a desire to improve the operational time of the Thomson scattering diagnostic camera which was being saturated with light generated from overheated tiles. Additionally there was a desire to reduce the carbon contamination of the plasma, which was reaching greater than 6% in high performance plasmas [3], which is generated from the ablation of overheated tile surfaces. These specific issues will be addressed following a general examination of tile design and operational characteristics.

II. TILE DESIGN

For the RDP structures, the inertially cooled, plasma facing, graphite tiles are mechanically attached to the water-cooled support plates or rings whereas the majority of the tiles are attached directly to the water-cooled walls of the vacuum vessel. A layer of flexible graphite (Grafoil®) is used as a compliant heat transfer interface between the tiles and the cooled walls and rings. To ensure good contact and maintain

*Work supported by U.S. Department of Energy under Contract No. DE-AC03-99ER54463.

tile position in the event of creep of the compliant Grafoil® interface (Fig. 2), a stack of four Belleville washers at each attachment point are pre-loaded during the installation of the tiles. In the existing configuration, the nominal toroidal installation gap between the tiles is 2.5 mm. On the centerpost of the vacuum vessel, in addition to the 2.5 mm gap, the tiles also have a flat plasma facing surface. This creates a faceted surface on the centerpost, with the facets being equal to the tile width. The tile design with the features described here utilizes the experience gained from the previous extensive engineering, analysis, and testing effort [4] and in the successful operation of 1500 tiles in the divertor and first wall of DIII-D for the past 12 years. Though the tile performance has been adequate, a requirement to increase plasma performance by reducing plasma carbon contamination is prompting a re-examination of tile geometry and material.

III. THERMAL PERFORMANCE

The tiles are machined out of blocks of ATJ graphite material which has an axisymmetric thermal conductivity of 90 W/m-K° . For this material, the maximum permissible temperature on the face of the tiles is 1500°C while the localized limit on the edges is 1800°C , the temperature at which ablation occurs. These inertially cooled tiles absorb energy during a plasma experiment, or pulse, and cool down to 30°C in the 10 min between pulses by conducting through the Grafoil®, to the water-cooled panels and vacuum vessel wall. The temperature of a plasma facing component PFC is thus a function of tile geometry, the material of the tile, the heat of the plasma (q_{II}), the angle of the field line (FLA), the duration of the pulse, and area of the surface exposed.

IV. TILE EDGE HEATING

Tile geometry is critical in plasma heat loading on tile surfaces. For tiles on the vacuum vessel centerpost, the angle of the faceted tile increases the angle of the tile relative to the plasma. As can be seen in Fig. 2, the toroidal facets of the tiles concentrate the heat flux on the edges of the tiles rather than evenly distributing along the face. Making these surfaces cylindrical will effectively re-distribute the heat load along the face of the tile. This change is being incorporated in the RDP upgraded at the strikepoint regions on the centerpost, specifically on the top two rows of tiles on the centerpost (Fig. 1).

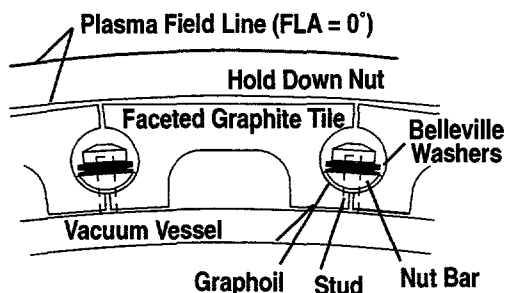

Fig. 2. Horizontal section of centerpost tiles.

Closer examination of tile geometry reveals an additional feature with an increased angle relative to the plasma field lines. This feature occurs at the gap between the tiles (Fig. 3). In this region a surface approximately perpendicular to the plasma field lines is exposed. This area increases even further as the field line angle increases. Assuming a $q_{II} = 100 \text{ MW/m}^2$, a FLA of 5° will produce a tile surface heat flux of 8.71 MW/m^2 . With these values, it is calculated that the surface of the tile will reach its limiting temperature of 1500°C in 3.5 s. Under these conditions, the tile edges are calculated to reach 2200°C [4]. For a shallower FLA of 2.5° , the surface heat flux will be 4.36 MW/m^2 and the limiting surface temperature will be reached in 11 s. Edge temperatures for these conditions are calculated to be 2039°C [5]. For both of these cases, the tile edge temperatures exceeded the ablation temperature of 1800°C . Observed tile wear and increased plasma carbon contamination support these calculations.

One way to reduce the heat load on the edges of the tiles is to reduce the angle of the surface relative to the plasma by chamfering it. Since the plasma is run in both toroidal directions, both sides of the tile have to be chamfered. While this will reduce the heat flux on the surface, chamfering on both sides increases the area exposed. The edge temperature rise was calculated [6] for a range of chamfer widths. As was previously discussed, no chamfer produces an edge temperature of 2200°C . Increasing this chamfer to 5 mm and 10 mm reduces the heat flux on the chamfered surfaces to 21.3 and 19.22 MW/m^2 , respectively, but because of the increased area the edge temperature increases as the chamfer increases to 2530°C and 2630°C . Thus, because of the requirement to have chamfers on both sides of the tile, chamfering increases the temperature rise on the tile edges.

Another method to reduce the heat load on the edges of the tiles is to reduce the area of the perpendicular surface exposed to the plasma. This is achieved by reducing the gap between the tiles. Closing the gap entirely will completely cover the perpendicular surfaces, however, this is impractical

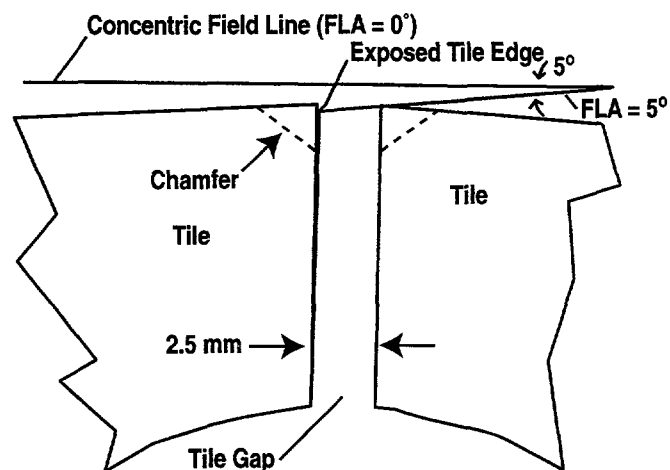

Fig. 3. Detail of horizontal section of centerpost tiles illustrating tile edge heating.

considering manufacturing and installation tolerances. Reducing the gap from 2.5 mm down to 1 mm can be achieved with a reasonable amount of tile customization as well tighter tolerances on tile machining. For a 1 mm gap and a q_{II} of 100 MW/m^2 , tile edge temperatures were calculated to reach 1747° and 1840°C respectively. This reduced tile gap is incorporated along with the cylindrical tile faces in the RDP upgrade.

V. THOMSON DUMP

Another localized region in DIII-D that was receiving an excessive heat load was in the tiles that border the Thomson dump on the vacuum vessel centerpost. These tiles are designed to provide an area on the centerpost that is shadowed from the field lines, with the possibility that field lines can run in either toroidal orientation as is shown in rows three and four in Fig. 4. While this has the effect of shadowing the tile on one side of the dump, it greatly increases the angle of the tile relative to the plasma field line on the other side of the dump. The geometry of the Thomson dump border tiles is shown in Fig. 5. A calculation was performed using the data of an actual plasma shot [6], with an input power of 6.9 MW and the ratio of total radiated power to total input power of 0.69. With these values, the heat flux on the 64.18° surface of the tile is 18 MW/m^2 . This is calculated with Eq. (1) [7],

$$Q_{\text{tile}} = \frac{P_{\text{input}} \times (1 - f_{\text{rad}}) \times f_{i/t} \times \sin[\alpha] \times \sin[\gamma + \beta + \nu]}{2\pi R_{\text{tan}} \times \sin[\beta] \times f_{\text{exp}} \times \lambda_p} \quad (1)$$

where

- Q_{tile} is the peak heat flux at the divertor strike point.
- P_{input} is the total input power.
- f_{rad} is the ratio of total radiated power to total input power = **0.69**.
- $f_{i/t}$ is the ratio of power into the outboard SOL to the power flowing into both the inboard and outboard SOL = **0.3**.
- R_{tan} is the major radius of the divertor strike point = **1.02 m**.
- f_{exp} is the flux expansion at the divertor target = **10**.
- λ_p is the midplane heat flux scrape off length = **0.01 m**.
- α is the angle between the divertor incline and the separatrix = **90°** .
- β is the angle between the impinging field line and the front side surface of the shield of the shield \approx **1.7°** .
- γ is the angle between the cut tile surface and the uncut tile surface = **25.82°** .
- ν is the angle between the uncut tile surface and the circle defined by $r = R_{\text{tan}}$ for a given Z location (positive or negative) = **-1.9°** .

which determines the heat flux on the Thomson dump border tiles as a function of plasma parameters, border tile geometry, and the geometry of the rest of the tiles in the toroidal row.

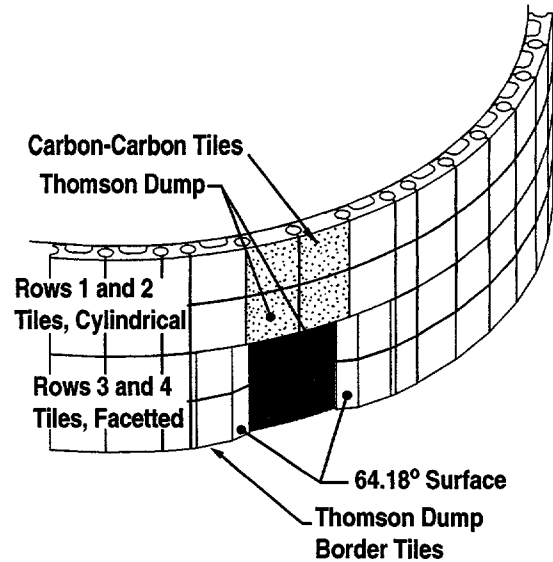

Fig. 4. Isometric view of Thomson dump and centerpost.

The heat flux on the rest of the facetted centerpost tiles in the row was calculated to be 6.9 MW/m^2 on the tile edges and 240 W/cm^2 for an average heat flux on the tile surface using the same plasma parameters as above. Applying the same aforementioned surface criteria and the above heat fluxes, the tiles will reach 1500°C in approximately 5 s. Meanwhile being exposed to 18 MW/m^2 during the same shot, the 64.18° surface of the Thomson dump border tiles will reach 2000°C in only 1 s. This calculation is confirmed by physical examination of these tile surfaces which indicates the presence of high heat flux by tile discoloration and worn edges.

Obviously, the surface heat flux on the tiles bordering the Thomson dump must be reduced. As was presented earlier, this can be accomplished by making the tile surfaces as parallel as possible to the plasma field lines. Ideally, this is a tile with a cylindrical plasma facing surface, which is the improvement that was made for the top two rows of tiles on the centerpost. However, there is an additional criteria of the Thomson dump diagnostics that needs to be addressed. This is that the infrared camera that views the dump becomes saturated if anything in its view exceeds 600°C . The goal is to maximize the operational time of the camera.

In light of this, a 2-dimensional analysis was performed of a basic tile shape for two different tile materials; an axisymmetric graphite material, grade ATJ Isomolded graphite (available from Ucar Carbon company) with a thermal conductivity of approximately 90 W/m-k , and a 3-dimensional carbon-carbon material supplied by Allied

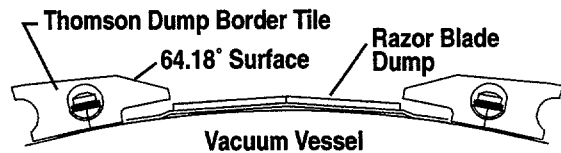

Fig. 5. Horizontal section of Thomson dump on centerpost of vacuum vessel.

Signal (865-19-4, Type II) with a thermal conductivity of approximately 220 W/m-K° . The results are presented in Fig. 6 which plots the time required to reach 600°C as a function of the heat flux and the material. For this geometry, as previously mentioned, and the worst case of $q_{II} = 100 \text{ MW/m}^2$ and a $\text{FLA} = 5^\circ$, the surface heat flux on the tiles is 8.71 MW/m^2 . For the standard, ATJ material, the time for the tile to reach 600°C to approximately 0.4 s. Using the carbon-carbon composite material, with a significantly higher thermal conductivity, roughly doubles to the time to thermal ablation by approximately 0.8 s. The edge heating of the tiles can be reduced by closing the gaps (which can be accomplished in localized areas) between the two sets of tiles in view of the Thomson infrared camera. These changes are being incorporated on the top two rows of the Thomson dump, which are the high heat flux strike point locations.

VI. SUMMARY AND CONCLUSION

The opportunity is being taken during the installation of the RDP upgrade to increase the thermal capabilities of PFCs and to possibly reduce plasma carbon contamination by reducing tile edge heating in high heat flux areas. Specifically, for rows one and two on the centerpost, the tile faces are being changed from a faceted face to a cylindrical face and the gaps between the tiles are being reduced from 2.5 mm to 1 mm. In the region of the Thomson dump, the top two rows of the dump are being replaced with cylindrical tiles made out of a carbon-carbon composite material with double the thermal conductivity of the standard material. This is done to improve plasma purity by removing carbon sources and improve diagnostic capability to better examine the plasma.

REFERENCES

[1] S.L. Allen, *et al.*, "Development of a Radiative Divertor for DIII-D," *J. Nucl. Mater.* **220-222**, 336 (1995).

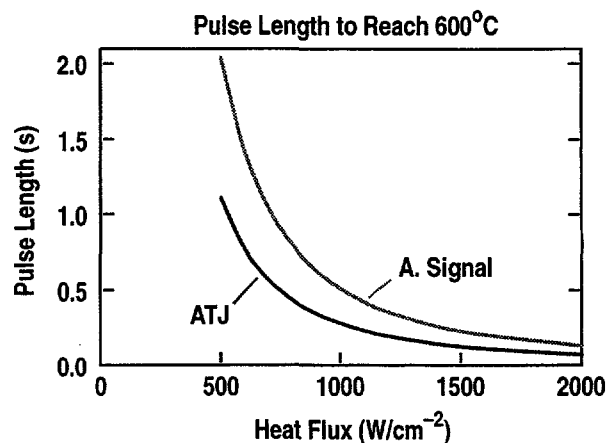

Fig. 6. Time to reach 600°C for a single pulse as a function of heat flux and material.

- [2] E.A. Lazarus, *et al.*, "A Comparison of Performance for Various Plasma Shapes in DIII-D," *Bull. Am. Phys. Soc.* **38** 1936 (1993).
- [3] W.P. West, *et al.*, "Carbon Influx in He and D Plasmas in DIII-D," *J. Nucl. Mater.* 266-269 (1999).
- [4] P.M. Anderson, *et al.*, "Development, Installation, and Initial Operation of DIII-D Graphite Armor Tiles," *Fusion Engineering and Design* **9**, 9 (1989).
- [5] C.B. Baxi, "Temperatures on the Edges of the Tiles," Internal Memo, February 9, 1999.
- [6] C.B. Baxi, "Effect of Chamfering Tile Edges," Internal Memo, February 16, 1999.
- [7] T.W. Petrie, "Power Loading on the Bump Tile Limiters Adjacent to the Inner Wall Thomson Dump," Internal Memo, September 15, 1998.