

LA-UR- 00 - 3896

Approved for public release;
distribution is unlimited.

Title: OPERATION OF A TRITIUM GLOVEBOX CLEAN-UP
SYSTEM USING ZIRCONIUM MANGANESE IRON AND
ZIRCONIUM TWO IRON METAL GETTERS

Author(s): Erica J. Larson
Katie J. Cook
Joseph R. Wermer
Dale G. Tuggle

Submitted to: International Symposium on Metal Hydrogen Systems
Noosa, Queensland, Australia
October 1-6
Conference Chair: Evan Gray
School of Science, Griffith University
Brisbane, QLD 4111, Australia
phone: +61 7 3875 7240

Unclassified/Not UCN

[Signature]
date

AUG 22 2000

Los Alamos

NATIONAL LABORATORY

Los Alamos National Laboratory, an affirmative action/equal opportunity employer, is operated by the University of California for the U.S. Department of Energy under contract W-7405-ENG-36. By acceptance of this article, the publisher recognizes that the U.S. Government retains a nonexclusive, royalty-free license to publish or reproduce the published form of this contribution, or to allow others to do so, for U.S. Government purposes. Los Alamos National Laboratory requests that the publisher identify this article as work performed under the auspices of the U.S. Department of Energy. Los Alamos National Laboratory strongly supports academic freedom and a researcher's right to publish; as an institution, however, the Laboratory does not endorse the viewpoint of a publication or guarantee its technical correctness.

DISCLAIMER

This report was prepared as an account of work sponsored by an agency of the United States Government. Neither the United States Government nor any agency thereof, nor any of their employees, make any warranty, express or implied, or assumes any legal liability or responsibility for the accuracy, completeness, or usefulness of any information, apparatus, product, or process disclosed, or represents that its use would not infringe privately owned rights. Reference herein to any specific commercial product, process, or service by trade name, trademark, manufacturer, or otherwise does not necessarily constitute or imply its endorsement, recommendation, or favoring by the United States Government or any agency thereof. The views and opinions of authors expressed herein do not necessarily state or reflect those of the United States Government or any agency thereof.

DISCLAIMER

Portions of this document may be illegible in electronic image products. Images are produced from the best available original document.

Operation of a Tritium Glovebox Clean-up System Using Zr-Mn-Fe and Zr₂Fe Metal Getters

Erica. J. Larson, Katie J. Cook, Joseph R. Wermer, Dale G. Tuggle
Engineering Sciences and Applications Division,
Tritium Science and Engineering Group, Mailstop C348
Los Alamos National Laboratory,
Los Alamos, NM 87545 USA

Abstract

A metal hydride-based tritium clean-up system has been successfully operated for more than four years on an 11 m³ helium/nitrogen glovebox which was used for handling metal tritide powders. The clean-up system consists of two beds: 1) a Zr-Mn-Fe (in a 10% by weight Al binder, SAES ST909) bed operating at 675°C followed by 2) a Zr₂Fe (SAES ST198) bed operating at 250°C. The Zr-Mn-Fe bed serves to condition the gas stream by cracking hydrogenous impurities (such as H₂O and hydrocarbons) and absorbing oxygen and carbon. The Zr₂Fe bed absorbs the hydrogen isotopes from the flowing stream by forming a solid hydride compound. These beds contain 3 kilograms of Zr₂Fe and have been loaded routinely with 230-250 STP liters of hydrogen isotopes in earlier trials.

The Zr-Mn-Fe alloy exhibits an anomaly during activation, namely an exotherm upon initial exposure to nitrogen. The purpose of this work is to better understand this reaction. Nitrogen absorption studies were done in order to quantify the nitrogen taken up by the getter and to characterize the reaction kinetics. In addition, ST909 phases before and after the reaction were studied with x-ray diffraction.

Keywords: Zr₂Fe, Zr-Mn-Fe, ST198, ST909, getters

1. Introduction

Getters are composed of a metal or alloy that can trap particular chemical species. One subset of getters is metal hydrides. Because these materials will selectively remove hydrogen isotopes from a gas stream by forming hydrides, they provide an attractive way to clean-up tritium gas streams[1-4]. Unlike collection on molecular sieve beds, tritium can be trapped with getters without generating tritiated water, which is highly radiotoxic compared to gas phase tritium[1-5]. Furthermore, hydrogen isotopes trapped in a metal hydride getter can be recovered in their elemental form at a later time[4].

Zr₂Fe (SAES Getters ST198) is a metal hydride getter used at LANL to separate and store hydrogen isotopes including tritium from contaminated glovebox gas streams[4]. Gas stream impurities such as Q₂O, CQ₄, and NQ₃ (where Q is any hydrogen isotope) inhibit the ability of ST198 to absorb hydrogen isotopes by reducing the gettering capacity and slowing the sorption kinetics[6]. For this reason, impurities are normally removed from the gas stream with ZrMnFe (SAES Getters ST909) before sending the stream into the ST198 bed.

RECEIVED

DEC 13 2000

OSTI

ST909 is composed of equimolar quantities of zirconium (40.5% by weight), iron (25% by weight), manganese (24.5% by weight), and aluminum binder (10% by weight)[6, 7]. An ST909 getter bed will crack water with >90% efficiency when operated at temperatures exceeding 400°C and residence times of about 1 second[5]. The atomic oxygen is retained by the getter, but very little of the hydrogen isotopes are absorbed[6-9]. ST909 has also been shown to crack methane, carbon monoxide, and ammonia and retain the atomic carbon and nitrogen[6, 10].

The Zr-Mn-Fe alloy exhibits an anomaly during activation, namely an exotherm upon initial exposure to nitrogen. Understanding the source of this exotherm is important in determining the optimal activation conditions for the ST909. The purpose of this work is to characterize the reaction of nitrogen with ST909. Nitrogen absorption measurements were done in order to quantify the amount of nitrogen taken up by the ST909 pellets and to study the kinetics. The phases present in the ST909 material were also studied before and after heating and before and after nitriding with powder X-ray Diffraction (XRD) in order to understand changes that occur during activation and exposure to nitrogen. The results are used to suggest a reaction that may be responsible for the exotherm observed during the initial activation of the material.

2.0 Experimental

2.1 Nitrogen Absorption Experiments

Nitrogen absorption experiments were performed in order to quantify the amount of nitrogen absorbed by a known amount of getter material and to study the kinetics of nitrogen absorption. Figure 1 shows a schematic diagram of the stainless steel process loop used to perform the measurements. Three type J thermocouples were spot-welded to the sample tube to provide inputs to an Omega CN8500 temperature controller, an Omega CN375 high temperature limit controller, and a Field Point thermocouple input device interfaced to the data collection computer. Eight whole or crushed ST909 pellets (~ 4.8 g) were placed in a 50-70 mL stainless steel sample tube. The sample tube and manifold were evacuated to 5 microns with an Edwards ESDP12 scroll pump backed by a Pfeiffer TCP015 turbomolecular drag pump. Before exposing to nitrogen, the ST909 pellets were activated under vacuum by heating the sample tube to 725°C for one hour with a Watlow ceramic fiber heater. The sample tube temperature was regulated with the Omega CN8500 Temperature Controller, using one of the sample tube thermocouples as a sensory input. The pellets were then cooled to 675°C and a known volume of high purity (99.999%) nitrogen was delivered by measurement with a calibrated volume. While the temperature was held at 675°C, the drop in manifold pressure was monitored with two MKS Baratron capacitance manometers and the number of moles of nitrogen removed from the gas phase could be calculated at a given time. The number of moles of nitrogen absorbed by the ST909 pellets was equated to the number of moles removed from the gas phase. The output from the manometers was interfaced to the data collection computer with a Field Point 16 bit analog input device. Temperature and pressure data were collected and logged at regular intervals with an in-house LabView program.

2.2 Temperature Profile Experiments

Temperature profile experiments were done in order to determine at what conditions the exothermic reaction would be observed. The same manifold as described in section 2.1 and shown in Figure 1 was used. Eight whole or crushed ST909 pellets were placed in the sample tube and the manifold was evacuated for about 15 minutes. The ST909 pellets were then subjected to heating under the controlled conditions listed below:

- 1) Heat from room temperature to 725°C at ~ 7°C/minute under vacuum
- 2) Heat from room temperature to 725°C at ~ 7°C/minute without removing any outgassing from the pellets
- 3) Heat from room temperature to 725°C at ~ 7°C/minute in the presence of high purity nitrogen
- 4) Repeat Experiments (2) and (3). Before removing the pellets from the sample tube, cool to ~ 40°C and heat a second time in the presence of high purity nitrogen

The sample tube temperature was plotted over time. During the reaction, the heat released during the reaction was great enough that the temperature controller could no longer regulate the sample tube temperature. Therefore, a spike in the temperature profile indicated the presence of the exotherm.

2.3 Powder X-Ray Diffraction (XRD)

ST909 pellets were crushed with a mortar and pestle prior to collecting XRD data. Powder XRD patterns were obtained with a model TED Scintag X-Ray Powder Diffractometer with 1.540562Å X-Rays from Cu K α radiation. The diffractometer was continuously scanned through the two theta range of 20 to 100° with a step size of 0.03 and a scan rate of 0.5°/min. Phases were identified by comparing the peak interplanar spacings (d-values) and relative intensities to patterns in the Powder Diffraction Files (PDF) compiled by the JCPDS – International Center for Diffraction Data and previously published Zr-Mn-Fe data[8, 11, 12].

3.0 Results and Discussion

3.1 Nitrogen Absorption Experiments

Figure 2 displays the kinetics of the nitrogen absorption for two different lot numbers of ST909 pellets. Although the kinetics between the two different lots of sample differ substantially, ~0.0028 moles of nitrogen per gram of getter material were finally absorbed in both cases. Differences in the kinetics may be due to differences in particle sizes. Nitrogen absorption measurements on ST909 samples of different particle sizes are underway.

3.2 Temperature Profile Experiments

The results of the temperature profile experiments are shown in figures 3-4. In figure 3, the sample tube temperature versus time is plotted for experiments 1, 2, and 3 described in the experimental section. As can be seen, a temperature spike is observed only when the sample is heated in the presence of nitrogen. The manifold pressure is also plotted for the experiment in which nitrogen was present. It can be seen that a large absorption of nitrogen occurs at the same time as the heat release. From this data, we attribute the exotherm to a reaction between nitrogen and the getter or an impurity in the getter. The results of experiment 4 are plotted in figure 4. Plot (a) shows the temperature profile of

ST909 pellets that were first heated to 725°C without nitrogen, cooled, and reheated to 725°C with nitrogen, and plot (b) shows the corresponding moles of nitrogen that were absorbed. Plot (c) is the temperature profile of ST909 pellets that were heated twice with nitrogen present both times, and plot (d) shows the corresponding moles of nitrogen that were absorbed. Plots (a) and (c) demonstrate that the temperature spike is not observed during the second heating, whether the sample had previously been exposed to nitrogen or not. The temperature spike will not be observed at all if the pellets are heated in the absence of nitrogen first as shown in plot (a). This result suggests that the exothermic reaction normally observed during the activation of the ST909 beds can be avoided by heating the pellets to 725°C in vacuum before placing the beds in a nitrogen atmosphere. The second heating cycles in plots (c) and (d) shows that a temperature spike need not accompany nitrogen absorption, suggesting two different reactions involving nitrogen. One reaction is exothermic, and can be avoided by heating the pellets in vacuum beforehand as described earlier. The second reaction does not produce an exotherm.

3.3 Powder X-Ray Diffraction

Figure 5 shows an expanded region of the XRD patterns obtained from unreacted, heated, and nitrided ST909 pellets. The as received pellets produced a pattern containing three phases: Zr-Mn-Fe, Al, and a trace of ZrC. The calculated and observed diffraction pattern of the Zr-Mn-Fe intermetallic compound has been reported [8, 11, 12], and we observe the same pattern in our data. The presence of aluminum in the diffraction pattern is expected, because aluminum is a binder present in equimolar amounts to the other metals. After heating intact pellets to 725°C for about an hour, the XRD pattern changes somewhat. The Zr-Mn-Fe phase is still present, but the aluminum is gone. Some additional unidentified peaks have appeared, particularly at low diffraction angles. Figure 5 shows that the aluminum peaks at approximately 38.7° and 44.9° have disappeared in the heated ST909, while unidentified peaks at 38.2°, 44.2° and 45.5° have appeared. Because the melting point of aluminum is 660°C and the aluminum peaks no longer appear in the XRD pattern after the heating step, aluminum likely melts and alloys with one or more of the other ST909 constituents. This new alloy could be responsible for some of the new, unidentified peaks. ST909 pellets that were nitrided resulted in dramatically different XRD patterns as shown in figure 5. The hexagonal C14 Zr-Mn-Fe phase is virtually absent from the nitrided sample, and a new pattern that can be attributed to ZrN appears. Other unidentified peaks are also present.

Although we haven't been able to identify all of the phases present in the heated or nitrided ST909 samples, we can use the XRD information with the temperature cycling experiments to suggest an explanation for the exothermic reaction. When the ST909 pellets are heated for the first time in the presence of nitrogen, a large release of heat is observed once the pellets reach approximately 450°C. Perhaps the nitrogen is reacting exothermically with the zirconium in the Zr-Mn-Fe phase, resulting in the ZrN phase observed in the XRD patterns of the nitrided samples. If the pellets are initially heated without nitrogen, no exotherm is observed even when the pellets are heated a second time with nitrogen. Perhaps when heating without nitrogen, the aluminum alloys with the zirconium in the Zr-Mn-Fe. It is possible that this new alloy is not as reactive toward

nitrogen and would not produce an observable exotherm upon a second heating with nitrogen.

Unfortunately, we do not have direct evidence to support this explanation, because we have not yet been able to identify the source of all the peaks. We do not know exactly where the aluminum goes after the heating step. The peaks attributed to the ZrN phase in the nitrated XRD pattern are somewhat shifted from the positions recorded in the PDF database, suggesting that the zirconium involved in the nitrating reaction may be alloyed to some other metal like aluminum. There are other experiments that could be performed in order to demonstrate whether or not the proposed explanation is correct. For example, the temperature cycling experiments could be repeated with a mixture of aluminum and zirconium powders to see if an exothermic reaction is also observed during an initial heating in the presence of nitrogen. The phases present in the mixture before and after heating and before and after nitrating could also be studied with XRD to see whether an aluminum-zirconium alloys forms after heating to 725°C and to determine which phase absorbs the nitrogen. The XRD patterns would be much simpler and easier to interpret than the patterns associated with the ST909 material.

4.0 Conclusion

The absorption of nitrogen by the getter material Zr-Mn-Fe (SAES ST909) was characterized by absorption studies, temperature profile experiments, and XRD. An exothermic reaction between nitrogen and the getter material was observed at ~450°C when the ST909 was initially heated in the presence of nitrogen. Heating the getter material in the absence of nitrogen resulted in no observed exotherm even when the sample was heated a second time in nitrogen. It was suggested that nitrogen reacts with the zirconium in the ST909 to produce the exothermic reaction during the initial heating. Heating in the absence of nitrogen may cause the aluminum to melt and alloy with the zirconium, and reduce its reactivity toward the nitrogen. Further experiments to prove or disprove this speculation were proposed. Although the nitrogen-absorbing behavior of the ST909 is still not completely understood, these studies demonstrate that the ST909 getter beds could be heated once in vacuum before being placed on-line in the LANL clean-up system in order to avoid an exothermic reaction when nitrogen is introduced.

Acknowledgements

The authors would like to express their thanks to Dr. Ricardo Schwarz and Jose Archuleta for their help with the X-Ray Diffraction experiments and to Dr. Angus Lawson for his help in the analysis of the X-Ray Diffraction data. Valuable discussions with Michael Ferris and Dr. Claudio Boffito of SAES Getters is also acknowledged. This work was supported by ...

References

- [1] A. Nobile, W.C. Mosley, J.S. Holder, K.N. Brooks, *J. Alloys. Comp.* 206 (1994) 83.
- [2] K.J. Maynard, N.P. Kherani, W.T. Shmayda, *Fusion Technol.* 28 (1995) 1546.
- [3] S. Fukada, K. Tokunaga, M. Nishikawa, *Fusion Eng. Des.* 36 (1997) 471.
- [4] A. Nobile, T. Bieniewski, K. Frame, R. Little, K. Fisher, *Fusion Technol.* 28 (1995) 1558.
- [5] F. Ghezzi, W.T. Shmayda, G. Bonizzoni, *Fusion Technol.* 31 (1997) 75.
- [6] J.D. Baker, D.H. Meikrantz, R.J. Pawelko, R.A. Anderl, D.G. Tuggle, *J. Vac. Sci. Technol. A* 12 (1994) 548.
- [7] D.H. Meikrantz, J.D. Baker, G.L. Bourne, R.J. Pawelko, R.A. Anderl, D.G. Tuggle, H.R. Maltrud, *Trans. Fusion Technol.* 27 (1995) 14.
- [8] C. Boffito, A. Conte, G. Gasparini, *Trans. Fusion Technol.* 27 (1995) 69.
- [9] F. Ghezzi, C. Boffito, *Vacuum* 47 (1996) 991.
- [10] A.B. Antoniazzi, W.T. Shmayda, *Fusion Technol.* 30 (1996) 879.
- [11] D. Shaltiel, I. Jacob, D. Davidov, *J. Less Comm. Metals* 53 (1977) 117.
- [12] A. Suzuki, N. Nishimiya, S. Ono, *J. Less Comm. Metals* 89 (1983) 263.

Fig.1

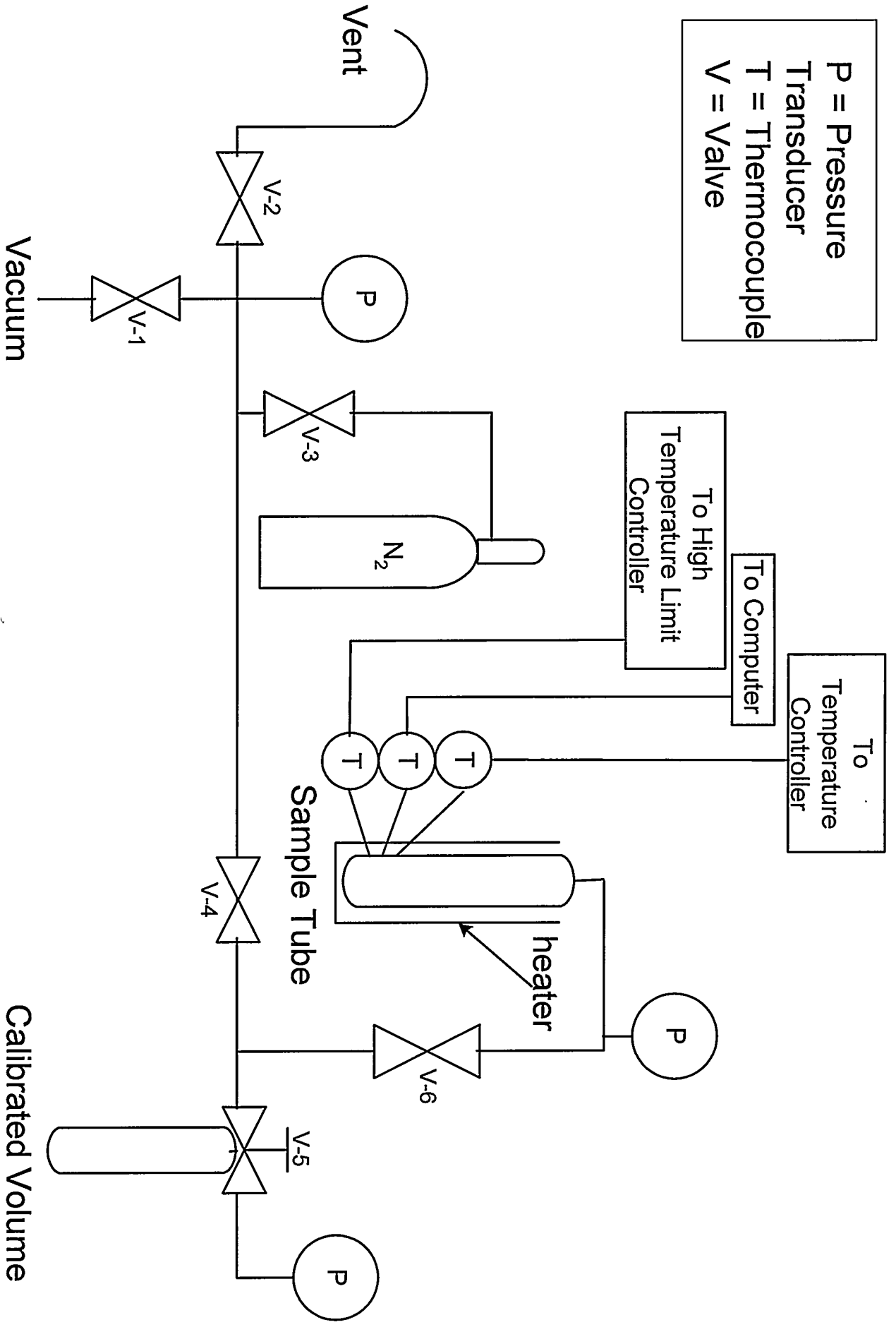

Fig. 2

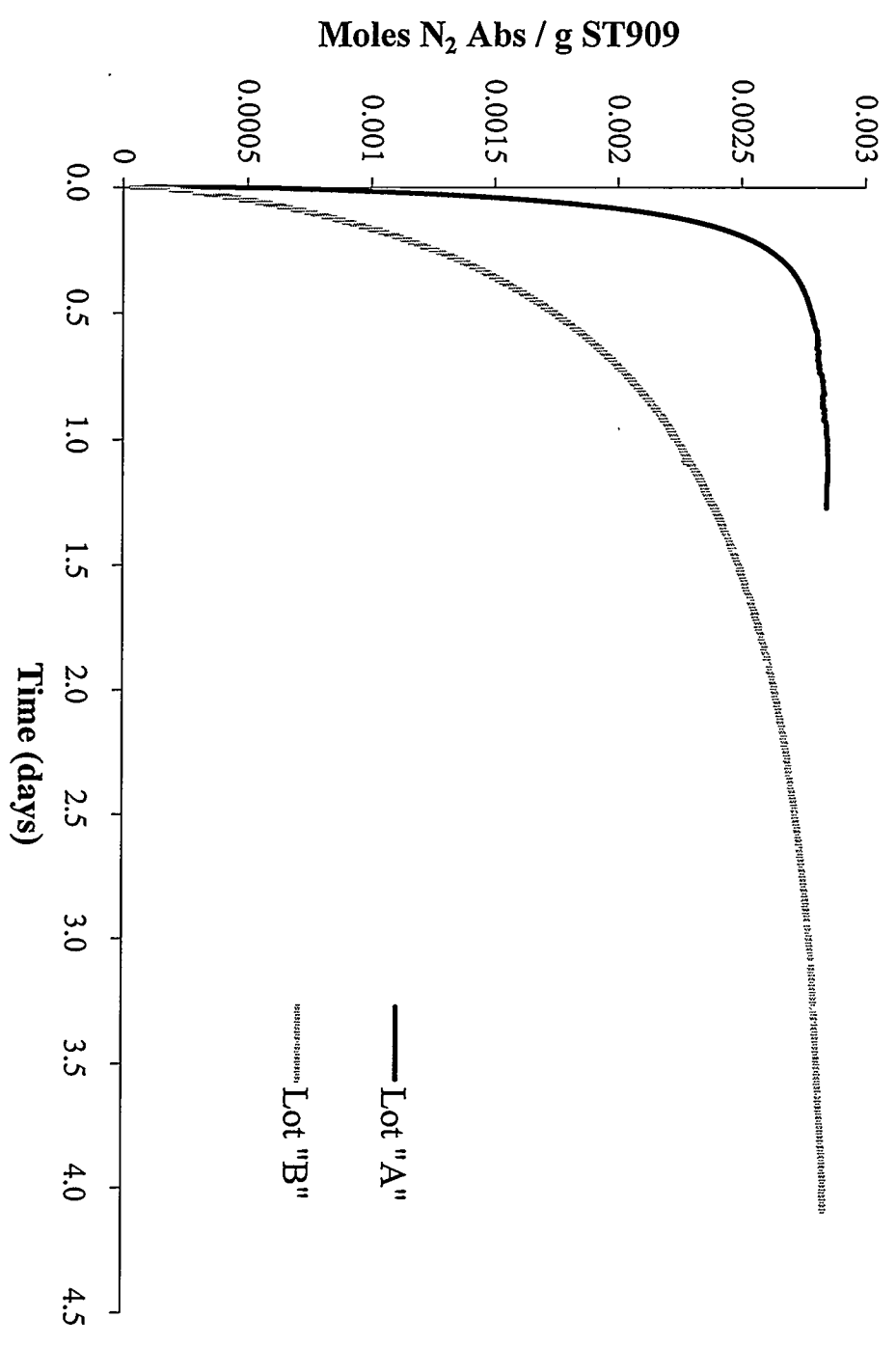

Fig 3

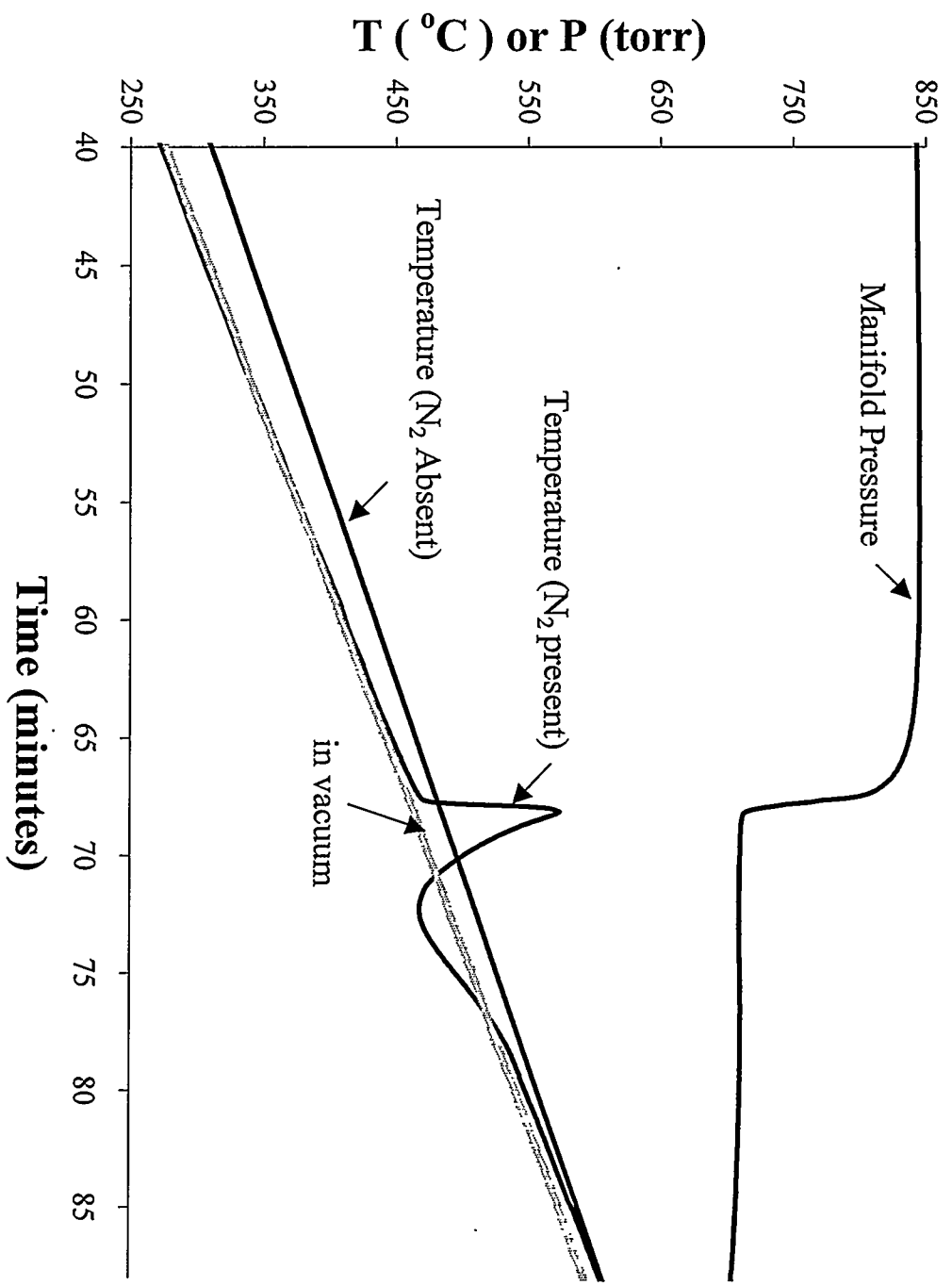

Fig 4

