

RECEIVED

DEC 8 1 1987

OSTI

CONF-980518--

SEISMIC ENGINEERING FOR AN EXPANDED TRITIUM FACILITY
AT LOS ALAMOS NATIONAL LABORATORY

Douglas E. Volkman¹, William B. Oliver², Elton E. Endebrock³,
Pradip K. Khan⁴, William R. Rebillet⁵, and John W. Cox⁶

Abstract

An existing complex of three single story concrete and masonry shear wall buildings will be integrated into an expanded tritium facility for neutron tube target loading. Known as the NTTL Project, the expanded plant is a major element of the Department of Energy's tritium program at the Los Alamos National Laboratory. This paper describes seismic evaluation and upgrade modifications for the 1950's concrete shear wall building; drift analyses of two 1980's CMU shear wall buildings; design of a new CMU shear wall building linking existing structures and providing personnel change room services; and design of a new steel frame building housing HVAC and electrical power and communication equipment for the complex. All buildings are closely adjacent and drift analysis to establish separation to prevent pounding is a major seismic engineering concern for the project.

¹Structural Engineer and Seismic Coordinator, Los Alamos National Laboratory,
Los Alamos, NM 87544

^{2,3,4,5,6}Structural Engineers, Merrick & Company, 195 East Road, Los Alamos, NM
87544

DTIC QUALITY INSPECTED 1

19980528 001

DISCLAIMER

This report was prepared as an account of work sponsored by an agency of the United States Government. Neither the United States Government nor any agency thereof, nor any of their employees, makes any warranty, express or implied, or assumes any legal liability or responsibility for the accuracy, completeness, or usefulness of any information, apparatus, product, or process disclosed, or represents that its use would not infringe privately owned rights. Reference herein to any specific commercial product, process, or service by trade name, trademark, manufacturer, or otherwise does not necessarily constitute or imply its endorsement, recommendation, or favoring by the United States Government or any agency thereof. The views and opinions of authors expressed herein do not necessarily state or reflect those of the United States Government or any agency thereof.

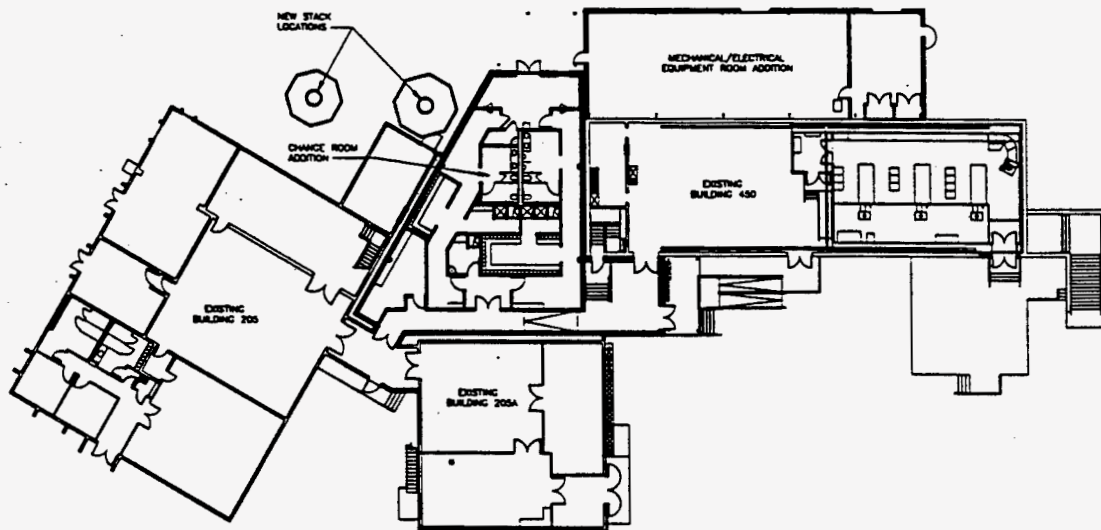

 OVERALL FLOOR PLAN

Introduction

This paper describes seismic engineering conducted during Title II definitive design phase for the Neutron Tube Target Loading (NTTL) Project at Los Alamos National Laboratory (LANL). Design was completed in CY 1996 and construction was begun in CY 1997. It is expected that the expanded NTTL facilities will be operational in CY 1998. The project is under direction of the Facilities, Security and Safeguards Division of LANL. Title II A/E design services and Title III project management services for configuration control during construction are provided by the Los Alamos Core Team of Merrick & Company.

An overall floor plan for the expanded NTTL facility is shown in Figure 1. Building 450 is an existing reinforced concrete building with a basement floor 3.9m (13 ft.) below grade having plan dimensions of 10.2m (34 ft.) by 33.6m (112 ft.). There are two roof heights at the first floor, 3.6m (12 ft.) and 6.3m (21 ft.) separated by a 2.7m (9 ft.) deep spandrel supported by the walls. The perimeter walls together with monolithic concrete floor and roof slabs form the shear wall system that resists lateral and vertical seismic loads. The building was constructed in 1951.

Figure 1: Overall floor plan for expanded tritium facility at Los Alamos National Laboratory

Buildings 205 and 205A are existing buildings of reinforced concrete masonry shear wall construction. They were constructed in the 1980's to house the present tritium engineering operations at LANL. The primary purpose for including these structures in the NTTL project was to evaluate drift under postulated seismic loads. This information was used in setting clearances from the new change room addition.

The Change Room Addition links the three existing buildings at the site and provides change room and entrance lobby space for operating personnel. This is a new building constructed with reinforced concrete masonry perimeter shear walls tied together with a reinforced concrete roof diaphragm supported on steel decking and bar joists. Interior gypsum board partitions were used as shear walls to carry seismic forces from the ceiling and ceiling-mounted equipment to ground.

Mechanical and electrical equipment servicing NTTL are installed in the Mechanical/Electrical Equipment Room (MEER) addition. This is a pre-engineered metal building constructed over a slab-on-grade foundation. Because it is closely adjacent to the Change Room and Building 450, the steel structure of the MEER is designed to the same level of seismic demand applied to the adjacent concrete and masonry structures.

The controlling design criteria were given in DOE-STD-1020 (DOE, 1994) and ASCE 4-86 (ASCE, 1986). Normalized site response spectra were provided by LANL through their structural design standards (LANL, 1995). Peak ground acceleration was established at 0.31g for the project. These together formed the design basis earthquake (DBE) for the NTTL site. The DBE was established from an extensive seismic hazards evaluation conducted by LANL (Wong, 1995).

Existing Building 450

This building is classified as Performance Category 3 (PC-3) for natural phenomenon (NPH) design. The PC-3 target seismic performance goals are occupant safety, continued operation and hazard confinement in case of a 10,000 year return period earthquake (DOE, 1995). Following is a description of evaluation of earthquake response and acceptance criteria for Building 450, and the upgrading required to meet current code criteria. An unusual requirement was to restore strength at new openings in walls for an emergency exit and for HVAC ducting penetrations. Details of the wall reinforcing are described.

Seismic Analysis

Criteria

Seismic evaluation of Building 450 was conducted following DOE-STD-1020. Acceptance Criteria are that scaled inelastic seismic demand plus concurrent non-seismic demand must be less than code capacity. This requirement is stated as follows:

$$D_{NS} + (SF) \times D_{S10}/F\mu \leq C_C \quad (1)$$

Where D_{NS} is the concurrent non-seismic demand, SF is a scale factor equal to 1.0 for PC-3 structures, D_{S10} is the elastic seismic demand at 10% damping determined from a dynamic analysis, $F\mu$ is an inelastic absorption factor applied to members, and C_C is the code-based

capacity. Since no allowance was made for inelastic response $F\mu$ was taken as 1.0

DOE-STD-1020 through referenced codes requires the following load combinations for ultimate strength analysis:

$$U = 1.4D + 1.7L + 1.7H \quad (2)$$

$$U = D + L' + E/F\mu \quad (3)$$

Where D is dead load, L is design live load including snow load, H is static soil load, L' is realistic live load conservatively taken as L, and E is seismic load including dynamic soil load. Seismic mass included dead weight of structure plus ten percent to include permanent attachments. No live load was included in the seismic mass since the first floor is not designated as a storage area.

Soil - structure interactions (SSI) have been found to be insignificant for buildings at LANL founded on undisturbed tuff. This is the case for Building 450. Potential frequency shifting as a result of SSI was provided for by broadening peaks of DBE response spectra to encompass frequencies of fundamental modes.

Stick Model

Stick modeling procedures described in ASCE 4 were used to capture the mass and stiffness characteristics of Building 450. Figure 2 shows the stick model features. Beam elements were used to represent each major structural element including walls, columns, spandrel beams, combined floor beams and slab, and combined roof beams and slab. Customary stick modeling procedures were extended to include out-of-plane flexibilities of the roof and floor systems. The model thus provided useful demand loads for vertical as well as lateral seismic input.

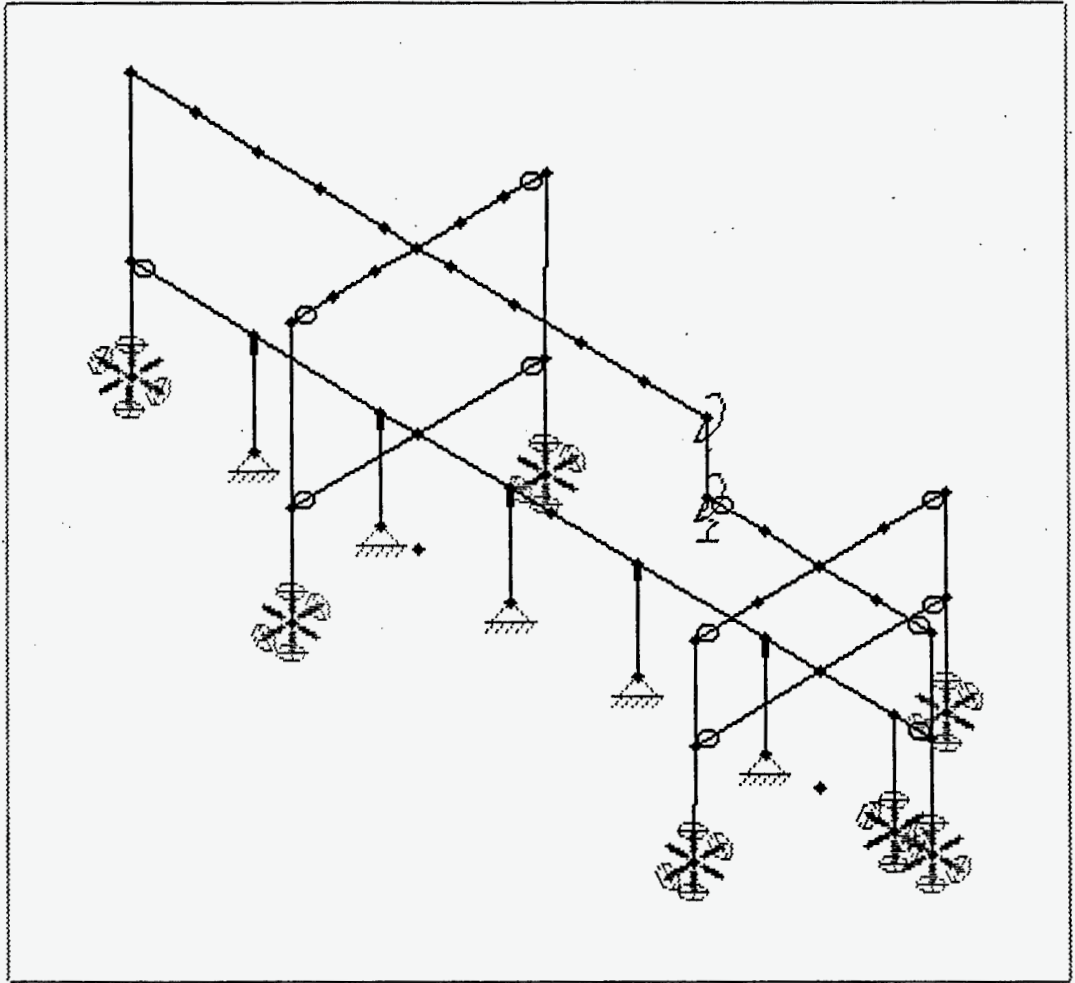

4

5"

Figure 2. Stick model of Building 450. Wheel symbols at supports indicate locked rotational degrees of freedom.

Code-specified concrete modulus of elasticity was reduced by 25% to account for cracking, as recommended by the ASCE working group (LLNL, 1993). Moment releases were specified at roof and floor beam connections to walls due to lack of sufficient dowels and embedment lengths required by modern codes to carry dead load moments at these locations.

Static, dynamic and seismic response spectrum analyses were conducted using the RISA-3D program. The output of computer runs were combined in spread sheets developed in MS Excel to calculate total demand on each element for the load combinations given in Equations 2 and 3.

Results

Fifty modes were sufficient to include more than 95% of mass in the dynamic analysis. In both lateral directions there were two dominant adjacent modes which captured 80% of mass. Vertical mass participation was spread over several separated modes. More than half of the important modes were at frequencies above 10 Hz. The significance of this is discussed in the following section.

With one exception all demand/capacity ratios (D/C) were less than 1.0, as required by Equation 1. Capacities were determined from current national consensus codes referenced in DOE-STD-1020, including those of the American Concrete Institute and the Uniform Building Code. DOE-STD-1020 recommends using strength properties for existing components at 95% exceedence levels. Accordingly, concrete compressive strength was taken as 2,285 psi based on results of a condition survey conducted on the building.

As mentioned above, Building 450 was constructed in 1951. Typical for many concrete buildings designed and constructed then, gravity loads were the main consideration. This is reflected in the detailing of reinforcement which shows very little continuity at intersections of walls with roof and floor slabs. Also, chord reinforcement for roof and floor diaphragms and at

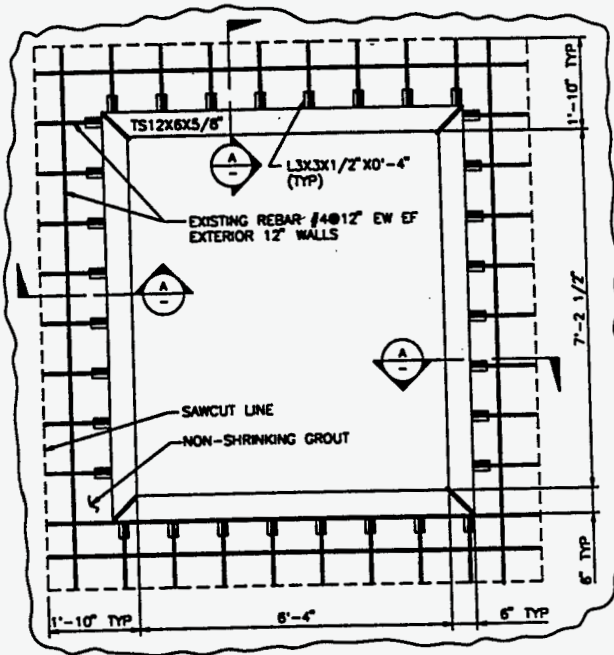
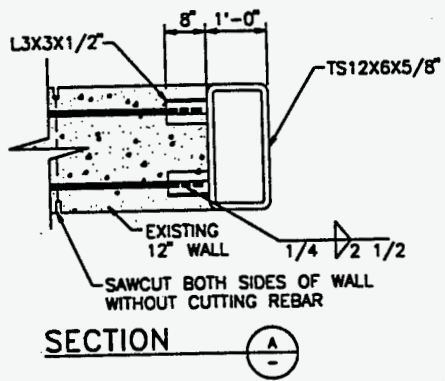

1.3

ends of shear walls is minimal. Nevertheless, the evaluation shows that structural performance is up to the NTTL seismic criteria except for the first floor shear connection at the west wall. The D/C ratio at this location was made less than 1.0 by infilling an existing floor opening to increase effective length of the connection.

Strengthening New Wall Openings

In order to provide HVAC service and an emergency exitway it was necessary to cut three new large openings in the existing outside walls of Building 450. The walls are 305 mm (12 inches) thick and have two curtains of #4 steel reinforcing bars at 305 mm (12 inches) on center each way. A "large opening" was defined as one causing one or more reinforcing bars in either or both directions to be severed. Finished opening sizes are 508 x 1118 mm (1'-8" x 3'-8") and 1092 x 2438 mm (3'-7" x 8'-0") for HVAC ducting. Finished opening size for the emergency exitway is 1930 x 2147 mm (6'-4" x 7'-2 1/2").

NTTL project criteria did not permit cutting any wall openings involving severed reinforcement without restoring the strength of the wall. Figure 3 shows typical details of how this was done (Ringo , 1996). The tubular steel perimeter frame is connected to exposed existing reinforcing bar by welding. Out-of-plane bending forces in the wall are collected as torsion in the frame member on one side of the opening, carried to the opposite side by bending of adjacent perpendicular members, then re-distributed to the wall again by torsion. It is essential that steel framing members are efficient in torsion and that the corner joints are mitered and carefully welded.

Figure 3. Details for strengthening at new wall openings to restore out-of-plane bending capacity.

This procedure was developed by Professor Boyd C. Ringo, P.E. It has been used widely by one major manufacturer in facilities requiring retrofit of concrete floor slabs to accommodate new openings for machinery and material handling equipment. Because of this successful application the procedure was considered proven technology for the NTTL project.

Existing Buildings 205 and 205A

Figure 3 shows the general arrangement of Building 205. The building is classified as performance category three (PC-3). All perimeter walls are constructed of 200 mm (8 inch) concrete masonry units (CMU) reinforced and fully grouted in every third cell. An exception is the north partition wall in the low bay area which is constructed of 300 mm (12 inch) CMU. The two levels of roof are constructed of precast prestressed double-T concrete beams. Connections between roof beams and walls is by matching steel plates embedded in T-beams and walls. Details follow industry standards for this type of construction.

A recent study conducted by LANL concluded that several structural upgrades to Building 205 were necessary to meet PC-3 seismic criteria for the site. These include a 75 mm (3 inch) thick lightweight reinforced concrete topping on the roof beams connected continuously to the perimeter shear walls. Modeling the building for seismic analysis proceeded with the upgraded configuration.

Building 205A construction is similar to Building 205. Main differences are that the CMU walls are fully grouted and reinforced and roof-to-wall connections are more robust. The LANL study concluded that building 205A is PC-3 service worthy.

Seismic Analysis

Seismic analysis of Building 205 was conducted primarily to estimate maximum lateral drift toward the NTTL change room addition in the event of a DBE. Figure 4 shows the stick model used for this purpose. Rectangular wall dimensions were entered as a standard shape allowing the computer graphics to produce the rendered members shown.

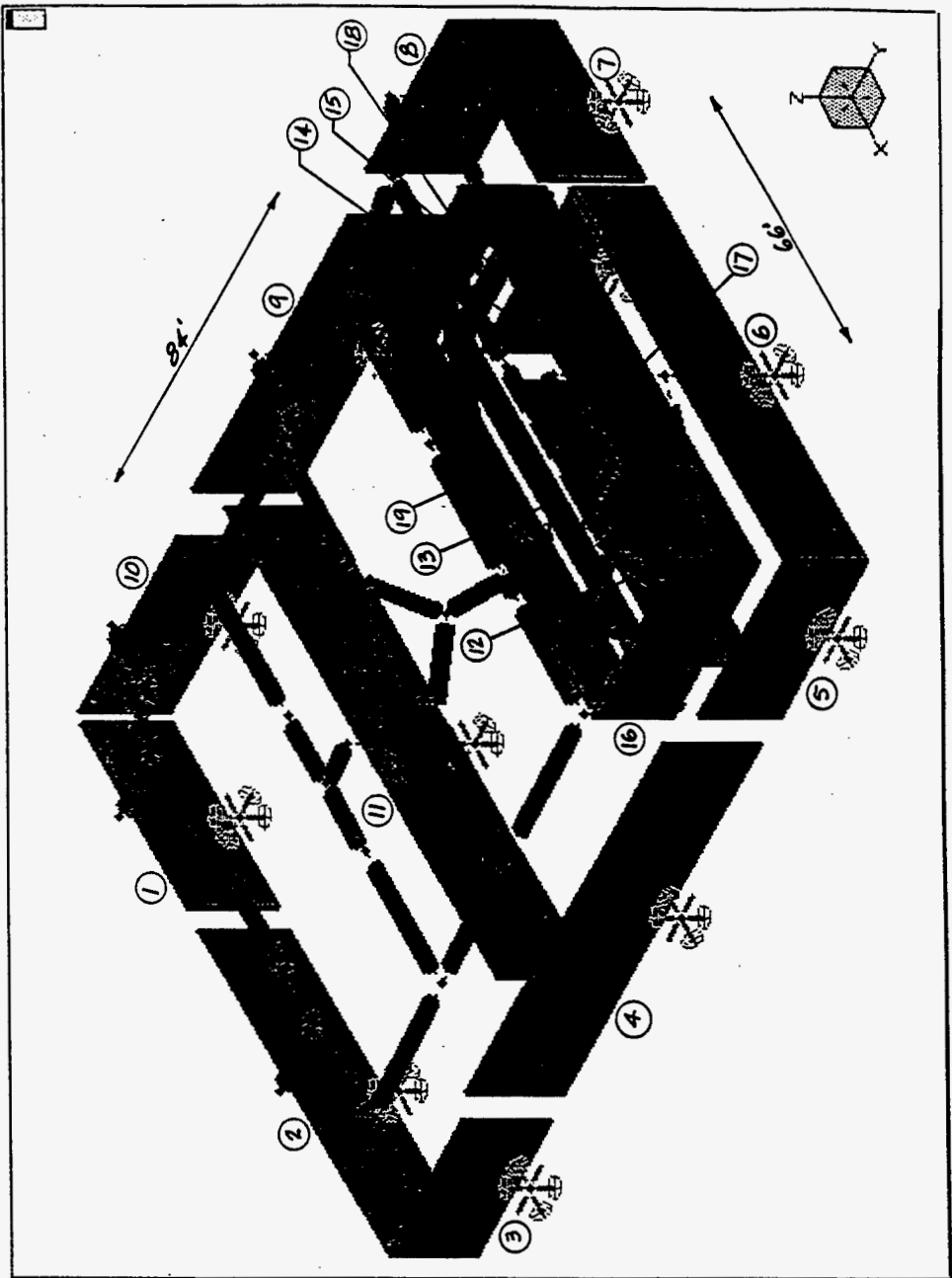

Figure 4. Stick model of Building 205 with walls rendered to show general arrangement of elements.

For purposes of stick modeling the building was partitioned into nineteen shear walls connected at the top with a rigid, weightless framework in the plane of the roof to simulate a rigid diaphragm. A rigid roof diaphragm was assumed based on the plans for upgrading described above. Roof mass was lumped at the trusswork node points to account for in-plane mass moment of inertia of the roof. It was also assumed that response to vertical acceleration will not contribute to lateral drift at roof level. For this reason out-of-plane flexibility of the roof was not modeled.

Twenty modes were sufficient to include 100% of mass in the dynamic analysis. Response computations by RISA-3D were done using the SRSS method of modal combination modified by the CQC procedure to accommodate closely spaced modes. Of the six most important modes, five were at frequencies above 10 Hz. Kennedy concludes that the in-phase tendencies of these higher frequency modes can lead to unconservative results in response spectrum analysis when SRSS/CQC procedures for combining modes are used (Kennedy, 1994). He states that the Gupta or a similar method of modal combination should be used when the dynamic model contains more than one significant mode at a frequency higher than that associated with the peak region of the

response spectrum. These methods are described by Kennedy in his paper. The Gupta method has been adopted for inclusion in the revised version of ASCE 4, now in publication, where it is referred to as the general modal combination (GMC) rule.

Comparison of Modal Combination Procedures

To determine the difference in seismic response values for SRSS/CQC and GMC methods of modal combination, the RISA-3D model of Building 205 was also run on SAP 2000. This program was recently revised to include the GMC option. Results are given in Table 1. In-plane wall shears follow the trend described by Kennedy. The SRSS/CQC method leads to significantly unconservative values for total base shear and for in-plane shear for most of the first level walls, all of which are at the building supports. For the upper level walls away from supports, the SRSS/CQC method of modal combination leads to significant conservatism.

Results and Conclusions

Building 205A was analyzed in a manner similar to that used for Building 205. Roof level drift values computed for each building, including soil compliance at footings, are less than 7 mm (1/4 inch).

GMC, the Gupta method of ASCE 4 Revised, is the proper method of modal combination for response spectra analysis of structures with important mode frequencies above 10 Hz. The availability of GMC in commercial software makes this a practical requirement.

Table 1. Comparison of in-plane wall shear and base shear for Building 205 for two methods of modal combination in response spectrum analysis.

WALL	GMC	CQC	GMC+CQC
1	33.3	26.7	1.25
2	72.4	58.1	1.25
3	34.4	28.1	1.22
4	133.8	109.4	1.22
5	46.5	52.9	.88
6	85.0	88.0	.97
7	33.6	32.7	1.03
8	30.3	24.2	1.25
9	93.7	74.8	1.25
10	53.2	42.5	1.25
11	130.1	111.6	1.17
12	125.3	115.9	1.08
13	98.3	92.9	1.06
14	22.4	21.4	1.05
15	18.3	18.9	.97
16	37.2	46.0	.81
17	58.2	66.9	.87
18	45.0	54.9	.82
19	28.4	39.1	.73

(a) In-plane wall shear, kips

GMC General modal combination rule of ASCE 4 Revised
 CQC Complete quadratic combination variation of SRSS

X-DIR		Y-DIR	
GMC	CQC	GMC	CQC
447	384	382	295
GMC 16%>		GMC 29%>	

(b) Total base shear, kips

New Change Room Addition

This single story building includes both PC-2 and PC-3 areas. The south corridor and adjoining room and airlock are PC-3 and the remainder of the area is operationally PC-2. All structure in the building is designed to PC-3 criteria. Detailed design of the CMU shear walls using ultimate strength procedures was greatly facilitated by the CMD94 computer program (CMACN, 1996).

Seismic analysis was performed using stick modeling techniques described above for Buildings 450 and 205. The building is very stiff, having a minimum modal frequency of about 22 Hz. Calculated maximum drift is less than 1.0 mm (0.04 inches). Ten modes were sufficient to include more than 98% of the mass.

The change room addition is supported on continuous spread footings everywhere except adjacent to Building 450. The backfill here was not adequate for foundation pressures, and piers drilled to competent tuff and capped with grade beams were used for shear wall support. This design is adequate for vertical loads but could not resist lateral loading. For this purpose the floor slab was designed as a rigid diaphragm to transfer lateral seismic loads at the base of the walls supported by piers to other foundation elements.

Partition walls were designed to function as shear walls to carry ceiling lateral seismic loads to ground. The technology base which made this feasible was developed by the American Iron and Steel Institute in recently-completed testing of steel studs and gypsum board shear-walls

(AISI, 1996, and Serrett, 1996). This work together with low D/C ratios and additional attention to edge and field attachment details for the gypsum board led to an adequate design.

From the above discussion of modal combination methods for Building 205 it is clear that the change room addition and Building 450 are also candidates for GMC. The change room shear-walls are all at the building supports and all of the important horizontal modes have frequencies well above 10 Hz. The CQC method can be expected to show unconservative results for these members.

However, the horizontal response spectra with peaks extended to account for soil/structure interaction resulted in wall loads at least 50% higher than those for unaltered spectra. Assuming GMC increases over CQC are about the same as for Building 205 leaves about 25% margin to account for soil/structure interaction. Since only insignificant SSI effects for NTTL buildings are expected this margin is considered adequate.

A similar argument applies for Building 450.

New Mechanical/Electrical Equipment Room Addition

This structure is a pre-engineered metal frame building designed to PC-3 criteria. The requirement is due to proximity to Building 450 and the new change room addition making it necessary to impose close limits on lateral seismic drift. Control of building superstructure design to NTTL seismic criteria was accomplished through a specification imposing the standards and design basis earthquake described above in the introduction.

Wind loading was not controlling for any elements of the building. Confinement was not an issue in the structure design. As a result, the PC-3 wind missile requirement of DOE-STD-1020 was waived, making conventional metal siding and roof panels acceptable.

The foundation was designed by the NTTL project engineering team. It consists of spread footings, drilled piers adjacent to Building 450, and an integral floor slab serving as a rigid diaphragm tying the foundation elements together. The above discussion for the change room foundation also applies here.

References

- AISI (American Iron and Steel Institute). "Shear Wall Design Guide." Publication RG-9604, Washington, 1996.
- ASCE (American Society of Civil Engineers). "Standard for Seismic Analysis of Safety-Related Nuclear Structures and Commentary." ASCE Standard 4-86, New York, 1986.
- CMACN (Concrete Masonry Association of California and Nevada). "Computer Aided Design of Reinforced Concrete and Clay Masonry Elements in Accordance with the 1994 Uniform Building Code." Citrus Heights, CA, 1996.

DOE (U.S. Department of Energy). "Standard for Natural Phenomena Hazards Design and Evaluation Criteria for Department of Energy Facilities." DOE-STD-1020-94, Washington, 1994.

Kennedy, R. P. "Position Paper on Response Combinations." Appendix B, NUREG-1061, Volume 4, U.S. Nuclear Regulatory Commission, Washington, 1994.

LANL (Los Alamos National Laboratory). "Facilities Engineering Standards - Structural." Facilities, Security and Safeguards Division, Los Alamos, 1995.

LLNL (Lawrence Livermore National Laboratory). "Stiffness of Low Rise Reinforced Concrete Shear Walls." Prepared by the Working Group on Stiffness of Concrete Shear Wall Structures of the American Society of Civil Engineers, UCRL-ID-113164, 1993.

Ringo, B. C. "Tubular Frame Openings in Existing Concrete Construction." Unpublished design record prepared for NTTL Project ID #13801 at Los Alamos National Laboratory. Cincinnati, 1996.

Serrett, R. "Shear Wall Values for Lightweight Steel Framing." Final Report Prepared for the American Iron and Steel Institute, Santa Clara, 1996.

Wong, I. "Seismic Hazards Evaluation of the Los Alamos National Laboratory." Final Report, Woodward-Clyde Federal Services, Oakland, 1995.

M98001306



Report Number (14) LA-UR--97-3243
CONF-980518--

Publ. Date (11) 199710

Sponsor Code (18) ^{DOE} MA, XF

JC Category (19) UC-903, DOE/ER

DOE