

ANL/XFD/CP-93013
CONF-970889--

RECEIVED

SEP 22 1997

OSTI

Submitted to SRI'97

As a Contributed Paper

Using the SRI'97 word template v1.2

**Smart X-ray Beam Position Monitor System Using Artificial
Intelligence Methods for the Advanced Photon Source Insertion-
Device Beamlines**

MASTER

DISTRIBUTION OF THIS DOCUMENT IS UNLIMITED *ph*

Corresponding author: Deming Shu

Experimental Facilities Division, Advanced Photon Source, Argonne

National Laboratory, Argonne, Illinois 60439, U. S. A.

Email: shud@aps.anl.gov

Phone: (630) 252-4684

Fax: (630) 252-9350

19980406 088

The submitted manuscript has been authored by a contractor of the U.S. Government under contract No. W-31-109-ENG-38. Accordingly, the U.S. Government retains a nonexclusive, royalty-free license to publish or reproduce the published form of this contribution, or allow others to do so, for U.S. Government purposes.

DISCLAIMER

This report was prepared as an account of work sponsored by an agency of the United States Government. Neither the United States Government nor any agency thereof, nor any of their employees, make any warranty, express or implied, or assumes any legal liability or responsibility for the accuracy, completeness, or usefulness of any information, apparatus, product, or process disclosed, or represents that its use would not infringe privately owned rights. Reference herein to any specific commercial product, process, or service by trade name, trademark, manufacturer, or otherwise does not necessarily constitute or imply its endorsement, recommendation, or favoring by the United States Government or any agency thereof. The views and opinions of authors expressed herein do not necessarily state or reflect those of the United States Government or any agency thereof.

Smart X-ray Beam Position Monitor System Using Artificial Intelligence Methods for the Advanced Photon Source Insertion-Device Beamlines

Deming Shu,^{a*} Hai Ding,^a Juan Barraza,^a Tuncer M. Kuzay,^a Dean Haeffner,^a and Mohan Ramanathan^a

^aExperimental Facilities Division, Advanced Photon Source, Argonne National Laboratory, Argonne, Illinois 60439, U. S. A., U. S. A.

Email: shud@aps.anl.gov

Abstract

At the Advanced Photon Source (APS), each insertion device (ID) beamline front end has two XBPMs to monitor the X-ray beam position for both that vertical and horizontal directions. Performance challenges for a conventional photoemission-type X-ray beam position monitor (XBPM) during operations are contamination of the signal from the neighbouring bending-magnet sources and the sensitivity of the XBPM to the insertion-device (ID) gap variations. Problems are exacerbated because users change the ID gap during their operations, and hence the percentage level of the contamination in the front-end XBPM signals varies.

A smart XBPM system with a high-speed digital signal processor has been built at the Advanced Photon Source for the ID beamline front ends. The new version of the software, which uses an artificial intelligence method, provides a self-learning and self-calibration capability to the smart XBPM system. The structure of and recent test results with the system are presented in this paper.

1. Introduction

At the Advanced Photon Source (APS), each insertion device (ID) beamline front end has two XBPMs to monitor the X-ray beam position for both that vertical and horizontal directions. Both the first and second XBPM are located upstream of the user photon shutter so that they are functional whether the user shutter is open or closed. The XBPMs measure photoelectrons

generated by the sensory blades and deduce the beam position by comparison of the relative signals from the blades. Analytical and experimental results proved that CVD diamond is a good choice for the APS high-heat-load XBPM blade material because of its superior thermophysical properties (Shu et al., 1992). The major advantage of the XBPM is its high positioning sensitivity. Besides that, compared to the particle beam position monitors in the storage ring, the front end XBPMs have much higher sensitivity to the X-ray beam angular motion simply because they are located far away from the source.

A design challenge for a conventional photoemission-type XBPM for ID beamline is the bending-magnet contamination of the signal and the sensitivity of the XBPM to the ID gap variations. Work at synchrotron radiation laboratories has shown that contamination signals caused by the bending-magnet (BM) emitted radiation become a major problem (Warwick, 1995). Problems are exacerbated for the XBPM when the IDs operate with different magnet gaps, because the percentage level of the contamination will be variable.

Since 1994, efforts have been made to design and develop a digital signal processor (DSP) based smart XBPM system for APS ID beamline front ends (Shu et al., 1996a). In this paper, we are presenting the recent progress on the development of the APS smart XBPM system, including the software structure, which uses an artificial intelligence method and provides a self-learning and self-calibration capability to the XBPM system. Test results with this novel smart system are also presented.

2. System Hardware Configuration

The APS smart XBPM system hardware configuration is depicted in Fig. 1. It includes:

- a pair of photoelectron emission-style beam position monitors using CVD diamond blades for the undulator beamline front ends,
- a set of photoelectron current amplifiers with an eight channel digitizer and auto-ranging controller (Meng, 1995),
- a digital signal processor (DSP) unit with an EEPROM database and input/output communication interfaces.(Wu, 1996),
- a system calibration controller with motor driver and encoder interface for XBPM calibration processes.

The XBPM in the front end is supported by a precision supporting unit, which consists of stepping-motor-driven vertical, horizontal, and rotational stages for XBPM calibration use.

The heart of the smart system is the DSP unit, which is equipped with a high-speed digital signal processor TMS320c40 from Texas Instruments Inc. The TMS320c40 is a floating-point processor designed specifically for digital parallel processing and real-time embedded applications. The key features of the TMS320c40 device, especially those to be used in this system, are its high-performance DSP CPU with 40 ns instruction cycle times and 40/32 bit single-cycle floating-point/integer multiplier for high performance in computationally intensive algorithms (Texas Instruments Inc., 1993). We have added 2 Mbytes EEPROM and 1 Mbytes RAM as external memory on the unit. Besides the three 24 bit digital parallel input/output interface and one RS232 serial port, we have also mounted a 4 channel, 12 bit A/D converter and a 5 channel, 12 bit D/A converter on the unit to provide the capability for a 4-20 mA current-loop analog interface.

3. Database Preparation

During the beamline and front end commissioning activities, the final fine-tuning of the storage ring and/or final adjustment of the front-end components is attempted. Based on the measurement data for the beam position in two locations in experiment stations with a pair of transmitting x-ray beam position monitors (Shu et al., 1996b), and in comparison with the data from the front-end X-ray BPMs, a new zero position is set after the synchrotron radiation beam commissioning. Fig. 2 shows a typical setup for the beamline front-end commissioning and XBPM database preparation.

Once the zero point of the beam-position coordinate system has been determined, the XBPM calibration unit, which includes a portable computer-based data acquisition system with interfaces to drive the XBPM stages in the beamline front end, launches a two-dimensional (vertical and horizontal) data-mapping scan for each XBPM. The mapping scan covers a 1.2 mm X 1.2 mm cross-sectional area for each XBPM with ten different undulator gap settings from 11 mm to 30 mm. During the mapping scan, the photoemission raw signals from each blade are recorded and labelled into a database. This database contains the calibration information about the XBPM local sensitivities and offset values with different gap sizes and different vertical and horizontal beam positions within the mapping range.

4. Software Using Artificial Intelligence Methods

In the operating mode, the DSP unit gets the XBPM signal raw data from the pre-amplifier/digitizer through one of the digital parallel port and groups them into an input buffer

array. Then the DSP calculates the data under the control of a signal normalization program. Based on the current undulator gap-size information from the real-time input, this self-adaptive program searches a previously prepared database from an EEPROM. After a step-by-step approaching process, the final beam position data (a pair for the beam positions at the first XBPM location and a pair for the beam angular displacement) is resolved and transmitted to a signal output buffer. There are two types of output data format available for users: 24 bit digital parallel output and 4-20 mA current loop for analog output. Both digital and analog output will keep the final beam position signal with a DC-100 Hz bandwidth.

Fig. 3 shows the smart XBPM system software structure, which consists of four major parts:

- a interrupt service program for XBPM raw data and undulator gap size input,
- a self-adaptive program with step-by-step approaching process for signal resolving and normalization output,
- a self-monitoring and self-learning program with a historical dynamic database,
- a self-calibration routine for second order correction.

Fig. 4 shows the step-by-step approaching process searching for beam position resolution. A typical searching process takes four steps and reaches a stable status as shown in Fig. 5.

The self-monitoring and self-learning program periodically records the smart XBPM output with the undulator gap setting and creates a historical dynamic database. Researching this historical performance database, the program determines if a second-order correction is necessary. If it is needed, a self-calibration process will be launched, and the program records the smart XBPM output results with different undulator gaps, then creates a second order correction table and puts it in use.

5. Test Results and Conclusions

To date, three smart XBPM systems have been installed on APS ID front ends, and they are operational. On-line preliminary tests began in August 1996. Fig. 6 shows a typical test result at the APS undulator beamline 1-ID front end. Table 1 shows the apparent x-ray beam position and angle measurements with and without the smart XBPM system, for varying undulator gaps from 11 to 30 mm while the particle beam beam position is stable.

The rest of the twenty ID front ends at the APS are expected to be furnished with smart XBPM systems within a year. Based on the experience from the prototype operation, we will determine the time duration of the calibration period and optimize the database structure.

Automatic calibration is necessary if the particle beam orbit changes frequently. If needed, the beam position at the neighboring bending-magnet front end may also be used as another database reference input.

Table 1

Apparent x-ray beam position and angle measurements with and without the smart XBPM system, for varying undulator gaps from 11 to 30 mm while the particle beam beam position is stable.

X BPM Readout	Without smart system	With smart system
1st XBPM vertical position (μm)	700	12
1st XBPM horizontal position (μm)	300	30
2nd XBPM vertical position (μm)	325	19
2nd XBPM horizontal position (μm)	2400	42
Vertical angular measurement (μrad)	275	6
Horizontal angular measurement (μrad)	600	8

Figure 1

Schematic of the APS ID front-end smart XBPM system hardware configuration.

Figure 2

Schematic of the setup for beamline front end commissioning and XBPM database preparation.

Figure 3

Block diagram of the smart XBPM system software structure.

Figure 4

The step-by-step approaching process searching for beam position resolution.

Figure 5

A typical step-by-step approaching takes four steps reaching a stable status.

Figure 6

Test results at the APS undulator beamline 1-ID front end showing the apparent x-ray vertical beam position measurement at the front-end 1st XBPM with and without the DSP-based smart system, for varying undulator gaps from 11 to 30 mm.

Acknowledgements

We acknowledge the help with the smart XBPM test from Messrs. Mark Keeffe, Michel Lehmuller, Tim Cundiff and Martin Smith. This work was supported by the U.S. Department of Energy, BES Materials Sciences, under Contract No. W-31-109-Eng-38.

References

- Meng F., Unpublished M. Sc Thesis, IIT, May 1995.
- Shu D., Rodricks B., Barraza J., Sanchez T., and Kuzay T., Nucl. Instru. and Meth. A 319 (1992) 56.
- Shu D., and Kuzay T., Smart X-ray Beam Position Monitor System for the Advanced Photon Source, Rev. Sci. Instrum. 67 (9), Sept. 1996a CD-ROM.
- Shu D., and Kuzay T., Design of the Commissioning filter/Mask/Window Assembly for Undulator Beamline Front Ends at the Advanced Photon Source, Rev. Sci. Instrum. 67 (9), Sept. 1996b CD-ROM.
- Texas Instruments Inc., TMS320c4x User's Guide, 1993.
- Warwick T. et al., Rev. Sci. Instru. 66(2) Feb. 1995.
- Wu X., Unpublished M. Sc Report, IIT, May 1996.

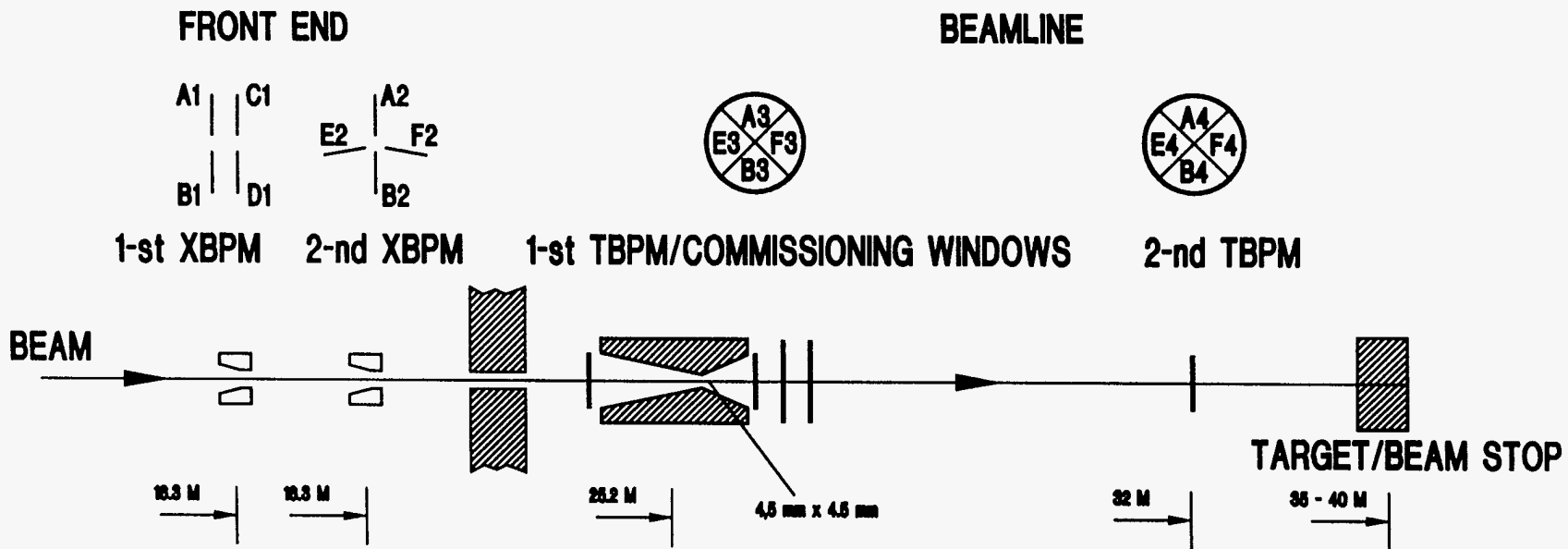

Fig 2.

Main Application Program

Initialization

Judge if the self calibration is enabled

Input: Gap size
Ring current
Orbit information
Other beam information

Search gap size

Calculate Vn1, Hn1, Vn2, Hn2

Locate V1, H1, V2, H2

Calculate Va, Ha

Output V1, H1, Va, Ha

Interrupt Service

Protect context

Read DIO input

Judge the channel selection bits, store in corresponding memory

Restore context

Wait for next interrupt

Self Monitoring Routine

Set monitoring principles and rules

Read gap size, V1, H1, Va, Ha

Compare the present result with the history database

Error range > set standard?

Wait for next monitoring period

Enable self calibration flag to be ready for self calibration

Wait for undulator gap size change to start self calibration

Self Calibration Routine

Undulator gap opens to 200mm and starts closing

Read present gap size

Record available gap size (11mm to 10mm) and position information (V1, H1, Va, Ha)

Undulator closing complete?

Wait for next gap size input from main application program

Modify the present data base, put in new calibration information and reconstruct

Disable self calibration flag

Wait for next self calibration period

Fig. 3

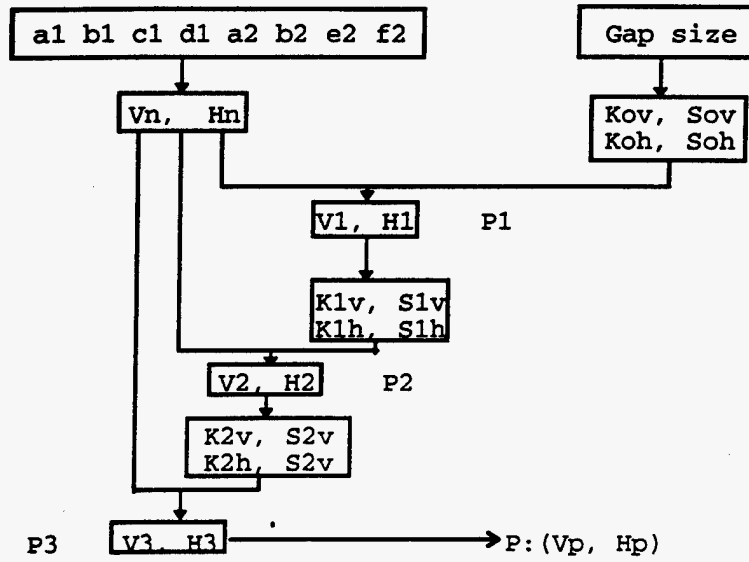
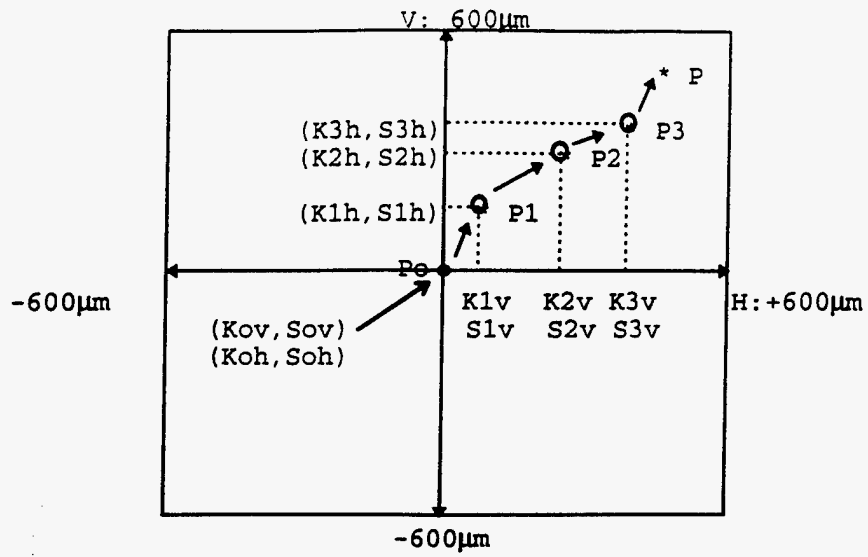

Fig. 4

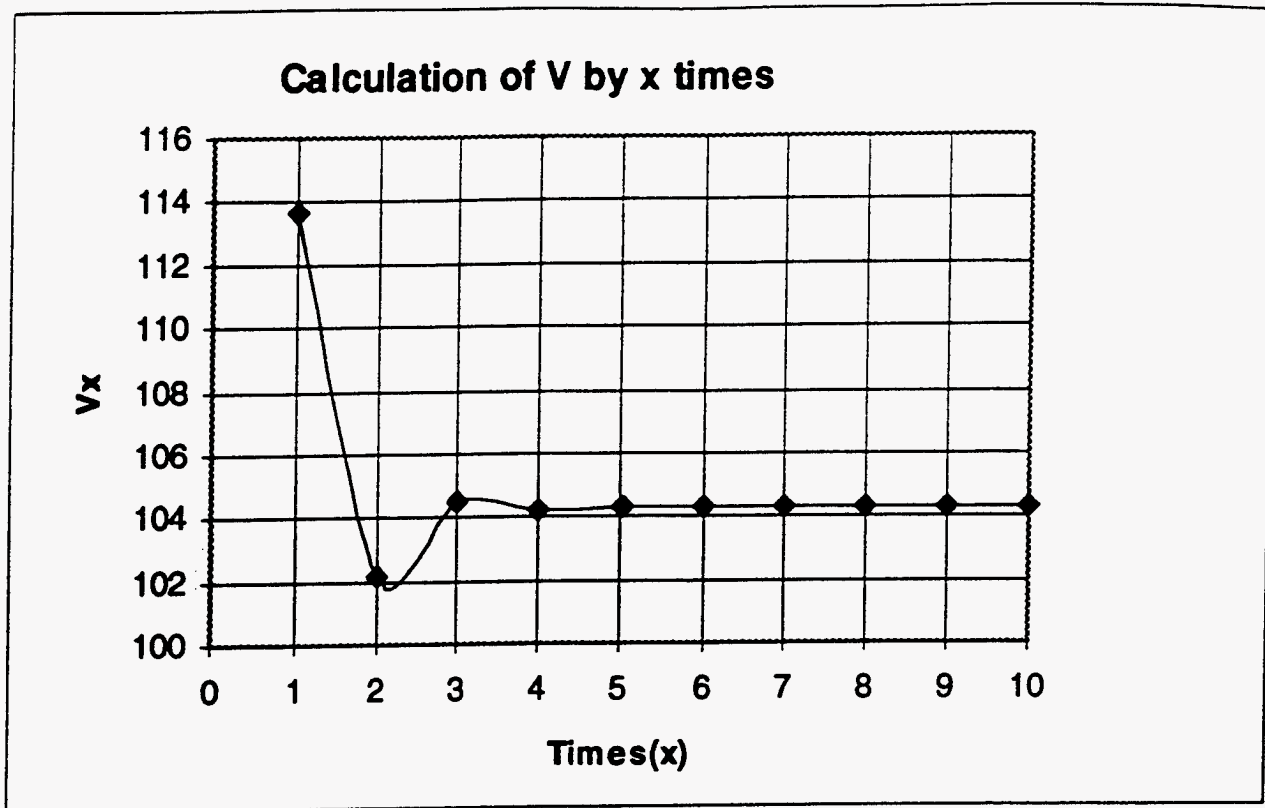

Fig. 5

APS Front End Smart XBPM Test at 1-ID

97030900.dat

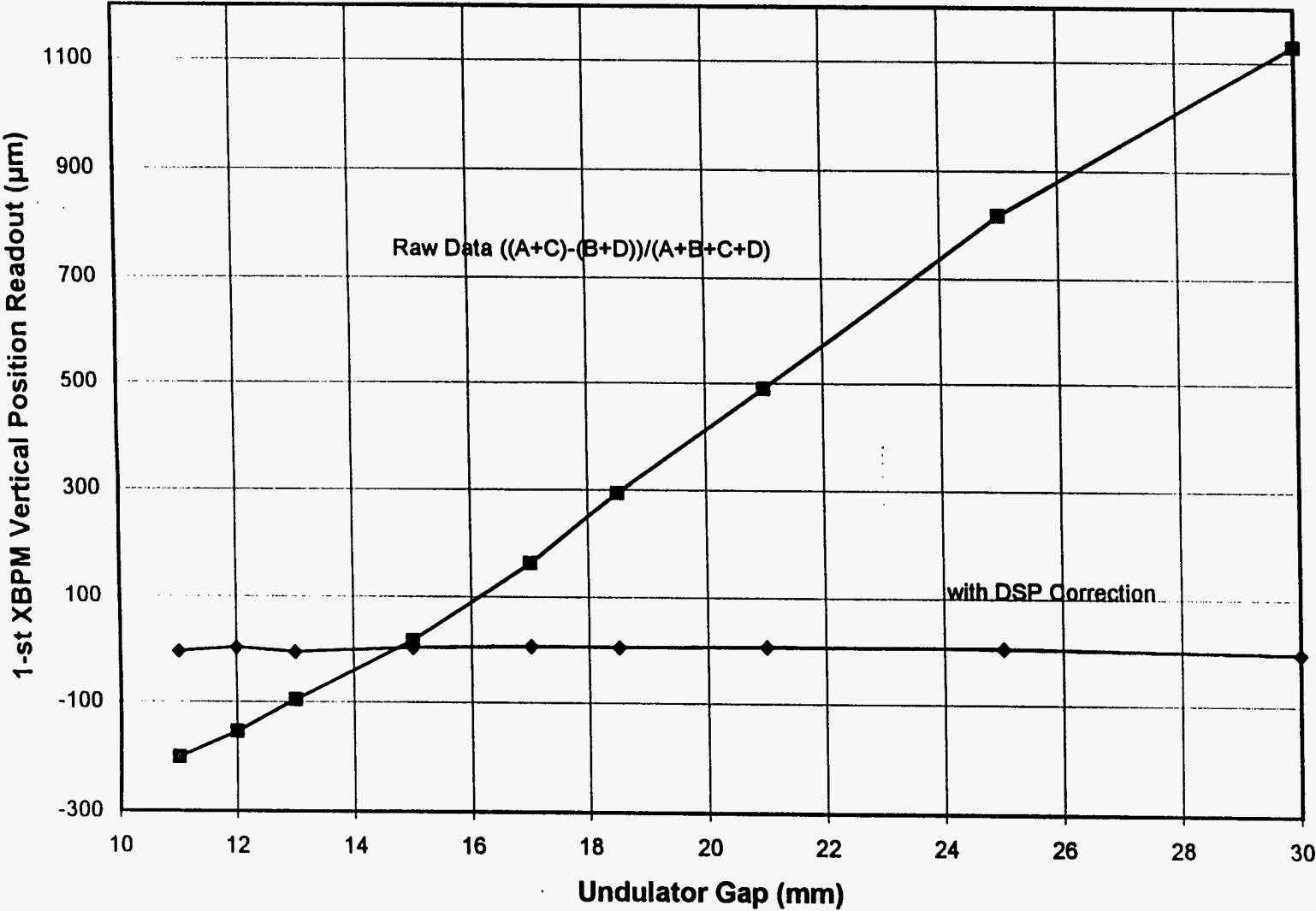

Fig. 6

M97054394



Report Number (14) ANL/XFD/CP--93013
CONF-970889--

Publ. Date (11) 199709

Sponsor Code (18) DOE/ER, XF

UC Category (19) UC-404, DOE/ER

DOE