

CONF-970464--11

**AN INVESTIGATION OF A PASSIVELY
CONTROLLED HAPTIC INTERFACE***

Hurley T. Davis
Oak Ridge National Laboratory
Robotics and Process Systems Division
P. O. Box 2008
Oak Ridge, Tennessee 37831-6426
(423) 576-9690

Wayne J. Book
Georgia Institute of Technology
The George W. Woodruff School
of Mechanical Engineering
Atlanta, Georgia 30332-0405
(404) 894-3247

RECEIVED

FEB 06 1997

OSTI

DISTRIBUTION OF THIS DOCUMENT IS UNLIMITED

To be presented at the
ANS SIXTH TOPICAL MEETING
on Robotics and Remote Systems
in Augusta, Georgia
April 27 - May 1, 1997

DISCLAIMER

MASTER

This report was prepared as an account of work sponsored by an agency of the United States Government. Neither the United States Government nor any agency thereof, nor any of their employees, makes any warranty, express or implied, or assumes any legal liability or responsibility for the accuracy, completeness, or usefulness of any information, apparatus, product, or process disclosed, or represents that its use would not infringe privately owned rights. Reference herein to any specific commercial product, process, or service by trade name, trademark, manufacturer, or otherwise does not necessarily constitute or imply its endorsement, recommendation, or favoring by the United States Government or any agency thereof. The views and opinions of authors expressed herein do not necessarily state or reflect those of the United States Government or any agency thereof.

*Oak Ridge National Laboratory, managed by Lockheed Martin Energy Research Corp. for the U.S. Department of Energy under contract number DE-AC05-96OR22464.

AN INVESTIGATION OF A PASSIVELY CONTROLLED HAPTIC INTERFACE*

Hurley T. Davis
Oak Ridge National Laboratory
P. O. Box 2008
Oak Ridge, Tennessee 37831-6426
(423) 576-9690

Wayne J. Book
Georgia Institute of Technology
School of Mechanical Engineering
Atlanta, Georgia 30332-0405
(404) 894-3247

ABSTRACT

Haptic interfaces enhance cooperation between humans and robotic manipulators by providing force and tactile feedback to the human user during the execution of arbitrary tasks. The use of active actuators in haptic displays presents a certain amount of risk since they are capable of providing unacceptable levels of energy to the systems upon which they operate. An alternative to providing numerous safeguards is to remove the sources of risk altogether. This research investigates the feasibility of trajectory control using passive devices, that is, devices that cannot add energy to the system. Passive actuators are capable only of removing energy from the system or transferring energy within the system. It is proposed that the utility of passive devices is greatly enhanced by the use of redundant actuators.

In a passive system, once motion is provided to the system, presumably by a human user, passive devices may be able to modify this motion to achieve a desired resultant trajectory. A mechanically passive, 2-Degree-of-Freedom (D.O.F.) manipulator has been designed and built. It is equipped with four passive actuators: two electromagnetic brakes and two electromagnetic clutches. This paper gives a review of the literature on passive robotics and describes the experimental test bed used in this research. Several control algorithms are investigated, resulting in the formulation of a *passive control law*.

*Research sponsored by the Office of Technology Development, U. S. Department of Energy, under contract DE-AC05-96OR22464 with Lockheed Martin Research Corp.

Several issues specific to controlling passive and/or redundantly actuated mechanisms are presented, and an algorithm for transforming general (active) controller commands into an appropriate set of passive actuator commands is presented. This algorithm capitalizes on the overlapping capabilities of the actuators and the enhanced control capabilities they provide for a passive device.

I. INTRODUCTION

There has been increasing interest in the study of passivity in the area of robotics in recent years. Many robotic applications, including haptic interfaces, surgical robots, and mechanical devices for exercise and rehabilitation, involve substantial interaction between the robotic manipulators and humans. The issue of safety, especially in health care applications, is of utmost concern. One commonly used approach to the issue of safety is the incorporation of redundant safety features and extensive testing before use. However, this does not remove the possibility of error and ensuing harm to nearby humans. An alternative approach is to remove the power-supplying components, such as electric motors or hydraulic cylinders, altogether.

In this work, investigation is made of a device made up entirely of *passive* components. By definition, passivity requires that the device do no positive work on its environment. Therefore, the passive components cannot generate arbitrary forces or motions but may be able to modify forces or motions provided by an external source, such as a human user, to produce passively controlled forces and motions. In addition to safety, passivity of the human-manipulator interface guarantees stability.

DISCLAIMER

**Portions of this document may be illegible
in electronic image products. Images are
produced from the best available original
document.**

However, uncertainties as to the utility of passive devices limit their present use. What are the limitations introduced by passivity? How can a manipulator perform useful tasks without doing any positive work on its environment? Are there any implications for control algorithms used with passive mechanisms?

This paper explores the use of passive mechanisms for control as well as control methodologies that enhance their capabilities. Several passive components and devices appearing in the literature are reviewed.

Finally, the Passive Trajectory Enhancing Robot (P-TER) is introduced. P-TER is a mechanically passive, 2-D.O.F. device developed at the Georgia Institute of Technology's Intelligent Machine Dynamics Laboratory.¹ This device uses electromagnetic brakes and clutches to constrain externally generated motion to a computer programmable path.

Research involving the development and use of passive devices in the broad area of robotics is reviewed. This is followed by a discussion of the concepts employed in the design of P-TER and the development of the experimental test bed. Then, an investigation of control algorithms for P-TER is presented, culminating in the proposal of a *passive impedance control* formulation. Finally, some preliminary simulation results are given, followed by conclusionary remarks and a list of references.

II. PASSIVE ROBOTICS

The issue of passivity comes up in several research areas. The use of passive systems in medical tasks offers a potentially higher level of safety. Continuous Passive Motion (CPM) is an application of robotic assistance in the physical therapy domain.² The physical therapist "teaches" the robot arm an appropriate path, and the arm is equipped with force sensors that could be used for trajectory control as well as to gather data during therapy. Unfortunately, current CPM arms tend to be inflexible and nonreprogrammable. Researchers at Oklahoma State University developed a passive robot to evaluate surgical correction of the scoliotic spine in the operating room.³

In more traditional robotics and control domains, the issue is often stability. It has been suggested that passivity of the manipulator can guarantee stability in tasks that require stable dynamic interaction with their environments. Dynamic interaction is a primary issue in the implementation of haptic, or tactile feedback,

interfaces. Haptic displays often attempt to implement virtual environments and tasks with force and sensory feedback. Hogan presented a unified approach to the control of dynamic interaction between a manipulator and its environment.⁴

Goswami and Peshkin introduced the topic of passive robotics in the context of mechanical computation.⁵ The mechanical device, or manipulator, computes a particular motion in response to a particular forcing. This relationship between force and motion, the admittance, can be thought of as the control law for the device. Goswami and Peshkin established a formulation to quantify the range of admittances passive devices could be designed to have. Schimmels and Peshkin extended this formulation to the problem of robotic assembly.^{6,7} They demonstrated an algorithm for designing a constant admittance matrix *a priori* for a particular device to perform a particular task.

Chapel and Su gave a manipulator a passive admittance to ensure the stability of the manipulator coupled with its environment.⁸ Li and Horowitz proposed the definition of a passive velocity field where a vector tangent to the desired velocity is defined everywhere in the workspace.⁹ In this case, the controller stores and releases energy but does not generate any.

One approach to building a programmable passive device is to develop programmably passive components. Laurin-Kovitz et. al. have developed designs and prototypes of components with programmable stiffness and programmable damping.¹⁰ A prototype tunable spring was designed which utilized two opposing, nonlinear springs. The effective stiffness is programmable by changing the spring lengths. A prototype damper consisting of seven channels of varying cross-section was designed and built which allows for 128 quantized impedances. These Programmable Passive Impedance (PPI) components are proposed to be incorporated into the drive of a robot.

The most recent work by Peshkin, Colgate, and Moore¹¹ explores the use of nonholonomic elements in implementing haptic displays. In this case passive actuators or nonholonomic elements are used to impose geometric constraints, as opposed to transmitting passive torques or forces. The idea is based upon using a nonholonomic element, such as a rolling wheel, as a continuously variable transmission (CVT) and then increasing its apparent degrees of freedom using feedback control.

III. EXPERIMENTAL TEST BED

To investigate the feasibility of controlled manipulation with a passive device, an experimental test bed has been designed and developed. The P-TER is a 2-D.O.F., mechanically passive manipulator (see Fig. 1). Kinematically, P-TER consists of a five-bar linkage, with the base of the robot serving as the ground link. The links labeled "1" and "2" are considered the primary links. These links are connected to concentric shafts, an inner shaft and an outer shaft, sharing a common axis of rotation perpendicular to the plane of motion. The angular positions of these two shafts define the joint angles of the manipulator. The remaining two links, "3" and "4", complete the parallelogram linkage. This design also allows for simplifications in the dynamic equations of motion for the manipulator.

A human user moves the device through the end-effector. The four electromagnetic actuators, two brakes and two clutches, share a common axis of rotation with each other as well as with the driven links. All four actuators are physically identical, consisting of opposing rotating plates lined with a friction material. The distinction between brakes and clutches lies in their function. Each driven link has a dedicated brake whose function is to remove energy from its corresponding link. One side of the brake is held stationary, while the other rotates with the corresponding link. Applying a current to the brake brings its friction surfaces together, resulting in a resistive torque being applied. Again, the brakes are used as control devices, and the magnitude of the resistive torque transmitted by the brake is proportional to the applied current.

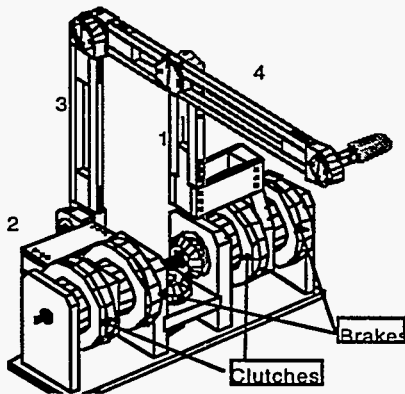

Fig. 1: The Passive Trajectory Enhancing Robot (P-TER)

The function of the clutches, on the other hand, is to couple the two primary links together in some advantageous way. In this case, one side of the clutch is connected to link 1, while the other is connected to link 2. Applying a current to a clutch essentially couples the two links together. The motivation behind this is as follows: instead of only being able to decelerate the individual links through the use of the brakes alone, the clutches allow energy to be transferred between links. This effectively allows us to accelerate one of the links without requiring additional energy flow into the system, thereby maintaining passivity.

P-TER is equipped with two clutches, each with distinct functionality. One clutch is the direct-coupling clutch, and the other is the inverted-coupling clutch. The control mechanism provided can be described as a superposition of the two separate devices shown in Fig. 2 and Figure 3.

Figure 2 depicts the two primary links connected to each other through two shafts coupled by a clutch. The clutch can be controlled to couple or release the shafts as appropriate for transferring energy between the links. Termed "direct coupling," this action would tend to make the two links rotate in the same direction. For example, if both links are moving in the same direction with arbitrary speeds, the direct-coupling clutch would slow down the faster link and speed up the slower link. However, if the links are moving in opposite directions, one of the links would be forced to stop and possibly change its direction. This action is implemented through the *inner* shaft, to which both links are directly connected.

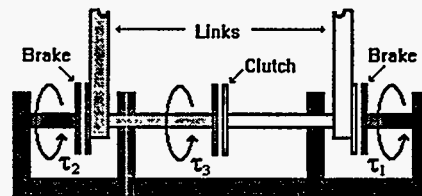

Fig. 2: Direct joint coupling mechanism

The second device shown in Figure 3 is nearly the same as the first, with the exception of the bevel gear differential placed between the two links. This is implemented through the *outer* shaft on P-TER. The outer shaft is actually two half-shafts connected through a bevel gear assembly such that the two halves rotate in opposite directions. In this mechanism, engaging the

clutch will tend to force the links to rotate in opposite directions. This action is termed "inverting coupling."

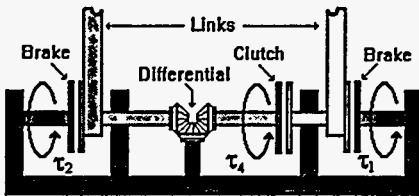

Fig. 3: Inverting joint coupling mechanism

The real advantage in using the clutches is the capability of transferring kinetic energy from one link to another. In general, the kinetic energy of the two links is arbitrary and dependent upon the user-input forces and velocities. By allowing the clutch friction surfaces to slip, a varying amount of energy can be transferred from one link to another.

P-TER is equipped with two potentiometers used to measure the joint positions. This joint position signal is differentiated and filtered numerically to yield the joint velocities. A strain gauge circuit mounted onto the handle acts as a 2-D.O.F. force sensor measuring the tip forces in the plane of motion.

The link lengths were chosen to simplify the equations of motion for the device. All terms dependent on the cross-product of the two joint velocities were thereby eliminated. An additional benefit is that all motion control devices are mounted at the stationary axis of rotation, eliminating the need to translate them with the linkage. By orienting P-TER for motion in a horizontal plane, gravity effects are eliminated, as seen in Figure 4.

The real-time control of P-TER is performed by an IBM-compatible personal computer running the DOS operating system. The PC houses an 80486 processor operating at 50 MHz and is equipped with analog-to-digital and digital-to-analog boards. All codes for the controller and the graphical user interface were written in the object-oriented language, C++.

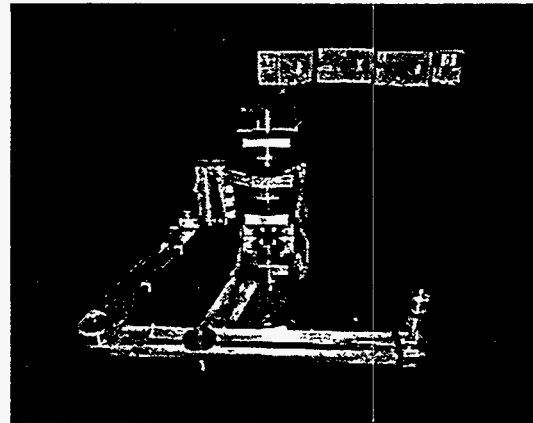

Fig. 4: P-TER: Current configuration

IV. INVESTIGATION OF CONTROL ALGORITHMS

To investigate the utility of P-TER, several control schemes were considered. As a precursor to the development of a full-featured haptic display, the initial focus is to achieve trajectory following. The goal is to be able to define a programmable path in software and have the arm follow this trajectory in response to arbitrary input tip forces and/or motions.

A. Passive Force Control

In his landmark paper on impedance control, Hogan argued that interaction between robotic manipulators and their environments is inherently nonlinear, and as such, sharp distinction should be made between impedances and admittances.⁴ Because of the existence of inertial objects in most environments, which yield motion in response to imparted forces, the environment should be modeled as an admittance; and, likewise, the manipulator should take on the role of an impedance.

For our task, we consider a different approach. It is the motion of the manipulator that we ultimately want to control. Likewise, the "environment" in this case is some external energy source, such as a human user applying forces to the manipulator end-effector. In a sense, we are proposing "admittance control." A similar approach was taken by Goswami et. al., who introduced the following "passive force control" law:

$$v = Af + v_0 \quad (1)$$

where v_0 is the nominal, or commanded, velocity; f is the applied force; and v is the resultant velocity. Each is a six-element column vector of translational and rotational components. A is the 6 x 6 accommodation, or inverse damping, matrix of the manipulator, mapping imparted forces into resultant velocities.

One shortcoming of this approach is that it only accounts for the force-velocity relationships of the system; no compliance or inertia is modeled.

B. Programmable Damping

An idea similar to both impedance control and passive force control was formulated for P-TER. By modeling the passive actuators as programmable dampers, an additional damping term could simply be added to the existing manipulator dynamics. The four passive actuators could be modeled as

$$\begin{aligned}\tau_{br1} &= -c_1\dot{\theta}_1 \\ \tau_{br2} &= -c_2\dot{\theta}_2 \\ \tau_{dir} &= -c_3(\dot{\theta}_1 - \dot{\theta}_2) \\ \tau_{inv} &= -c_4(\dot{\theta}_1 + \dot{\theta}_2)\end{aligned}\quad (2)$$

The t_i are the actuator torques for the two brakes and two clutches, respectively, and the c_i are the programmable joint space damping coefficients for each actuator. The coefficients are multiplied by the relative velocities of the friction surfaces of the corresponding brake or clutch. If all of the joint space damping coefficients are required to be nonnegative, then the above formulation will always result in a passive actuation strategy.

The dynamic equations for P-TER are given in Eq. (3). M is the 2 x 2 inertia tensor, V is the 2-element column vector of centrifugal terms, J is the manipulator Jacobian, F_{in} is the input force at the end-effector, and t_{act} is the vector of actuator torques. The usual Coriolis and gravity terms have been eliminated by the kinematic design of the linkages and the mounting of the links in the parallel plane, respectively.

$$M(\theta)\ddot{\theta} + V(\theta, \dot{\theta}) = J(\theta)^T F_{in} + t_{act} \quad (3)$$

It is important to note that the vector of actuator torques, t_{act} , is a 2-element column vector representing the net torque from all four of the actuators on each of the two primary links. It can be shown that this vector

takes on the form given in Eq. (4). Substitution of Eq. (4) into Eq. (2) yields Eqs. (5,6).

$$t_{act} = \begin{bmatrix} \tau_1 \\ \tau_2 \end{bmatrix} = \begin{bmatrix} \tau_{br1} - \tau_{dir} + \tau_{inv} \\ \tau_{br2} + \tau_{dir} + \tau_{inv} \end{bmatrix} \quad (4)$$

$$t_{act} = - \begin{bmatrix} (c_1 + c_3 + c_4) & -(c_3 - c_4) \\ -(c_3 - c_4) & (c_2 + c_3 + c_4) \end{bmatrix} \begin{bmatrix} \dot{\theta}_1 \\ \dot{\theta}_2 \end{bmatrix} \quad (5)$$

$$t_{act} = -C\dot{\theta}, \quad C = \begin{bmatrix} (c_1 + c_3 + c_4) & -(c_3 - c_4) \\ -(c_3 - c_4) & (c_2 + c_3 + c_4) \end{bmatrix} \quad (6)$$

Finally, the programmable damper formulation for the actuators can be substituted back into the original equation of motion, (3), to yield the joint space form of the programmable damping formulation, Eq. (7). This formulation improves on the passive force control law by including the existing dynamics of the manipulator in the equation of motion.

$$M\ddot{\theta} + C\dot{\theta} + V = J^T F_{in} \quad (7)$$

To achieve trajectory control, the desired trajectory is most easily defined in Cartesian task space coordinates rather than the joint space coordinates. By using the Jacobian, $J(q)$, and a rotation transformation, $R(q)$, the joint space dynamics (7) can be written in terms of task space coordinates (8). M_x , B_x , V_x , and f_{in} , are the transformed inertia, damping, centrifugal, and force terms, respectively. The task space coordinates are defined by a Cartesian coordinate frame fixed to the manipulator end-effector. The relationship between the task space and joint space damping matrices in particular is given in Eq. (9).

$$M_x \ddot{x} + B_x \dot{x} + V_x = f_{in} \quad (8)$$

$$C = J^T R B_x R^T J \quad (9)$$

The goal of trajectory control using programmable damping is summed up into three basic tasks:

- Specification of the desired trajectory in task space coordinates.
- Design of task space damping matrix to achieve desired path.
- Determination of corresponding joint space damping coefficients.

Several comments should be made about the programmable damping formulation. Both it and the

passive force control law were aimed toward programming a manipulator to provide "corrective action" in the completion of some tasks. Instead of being strict motion control laws, they are designed to modify arbitrary input forces/motions to improve overall task performance. In a sense, these formulations perform a sort of velocity control since the control action only directly affects the velocity. In the case of trajectory control, this control law would be used to redirect erroneous motion "back toward" the path, but it is not clear how to use the "velocity control" approach to achieve pure trajectory following, which is more formally a form of position control. Furthermore, once a desired path is specified in task space, it is not clear how to proceed in designing a satisfactory damping matrix, B_x , to follow this trajectory. One possibility may be to specify only a desired velocity *direction*, without regard for the magnitude of the velocity. It may then be possible to program the damping matrix to have preferential directions.

C. Passive Impedance Control

At this point we return to the original impedance control concept suggested by Hogan. The desired manipulator impedance is designed such that errors in the input motion produce corrective manipulator tip forces so that an arbitrary trajectory can be followed.

The use of impedance control is nothing new. However, implementing an impedance control law, or any control law for that matter, on a passive device has several implications. In general, the impedance controller commands torques that may violate the passivity condition and therefore will not be achievable by the passive actuators. Also, P-TER has four passive actuators to control only 2-D.O.F. The controller yields two components of control torque while the excitations of the four actuators must be determined.

The impedance controller attempts to replace the robot dynamics with a desired sum of task space impedances. A general, task space impedance control law is given in Eq. (10). X is the global Cartesian position vector, and M_x , B_x , K_x , and F_{in} are the desired task space inertia matrix, damping matrix, stiffness matrix, and input force vector, respectively. X_d is the desired position.

$$M_x \ddot{X} + B_x \dot{X} + K_x (X - X_d) = F_{in} \quad (10)$$

The Cartesian dynamics are solved for acceleration in Eq. (11). Using the Jacobian, the acceleration is then transformed into an equivalent joint space acceleration (12), and the actuator torques are then specified to achieve this desired acceleration (13).

$$\ddot{X} = M_x^{-1} [F_{in} - B_x \dot{X} - K_x (X - X_d)] \quad (11)$$

$$\ddot{\theta} = J^{-1} [\ddot{X} - \dot{J}\dot{\theta}] \quad (12)$$

$$\tau_{act} = \begin{bmatrix} \tau_{act1} \\ \tau_{act2} \end{bmatrix} = M\ddot{\theta} + V - J^T F_{in} \quad (13)$$

Where t_{act1} and t_{act2} are the two components of the desired torque vector. At this point the constraints of passivity are the primary concern. There are two primary manifestations of these constraints for impedance control implementation on P-TER.

- The torques generated by the actuators must be passive; that is, they must not perform work on the environment. In other words, the actuators must absorb energy, and the power output of the actuators is nonpositive.

$$\tau_{act}^T \dot{\theta} = P \leq 0 \quad (14)$$

- The excitations of four actuators must be determined from only two components of desired torque.

Charles attempted a geometric approach to the problem.¹² By manipulating the governing equations and using available manipulator state information, a "geometric region" of acceptable actuator excitations could be found.

Equation (15) shows the relationship between the vector of commanded torques and the individual actuator excitations. The variables t_1 and t_2 are the two components of torque commanded by the impedance controller. These torques must be achieved by specification of the four actuator torques - t_{br1} , t_{br2} , t_{dir} , and t_{inv} . The problem is mathematically underconstrained since there are four unknowns and only two equations. The equations can be rearranged to yield the actuator excitations in terms of the components of commanded torque, Eq. (16).

$$\begin{bmatrix} \tau_{act1} \\ \tau_{act2} \end{bmatrix} = \begin{bmatrix} \tau_{br1} + \tau_{dir} + \tau_{inv} \\ \tau_{br2} - \tau_{dir} + \tau_{inv} \end{bmatrix} \quad (15)$$

$$\begin{aligned}\tau_{dir} &= \frac{\tau_1 - \tau_2 - \tau_{br1} + \tau_{br2}}{2} \\ \tau_{inv} &= \frac{\tau_1 + \tau_2 - \tau_{br1} - \tau_{br2}}{2}\end{aligned}\quad (16)$$

The method is summarized as follows. First, the valid range of torques (magnitudes and directions) is determined for each actuator, depending on the current joint velocities, input forces, and actuator saturation levels. This results in a minimum and maximum commandable torque for each actuator. The minimum and maximum clutch torque values are used with Eqs. (16) and (17) to plot four intersecting lines in the $(\mathbf{t}_{br1}, \mathbf{t}_{br2})$ plane. The interior region of these intersecting lines defines a region of valid clutch torques. Four similar lines for the brake torques define a region of valid brake torques. Finally, if these two regions intersect, then any pair of brake torque values $(\mathbf{t}_{br1}, \mathbf{t}_{br2})$ in that region will satisfy Eq. (15).

Unfortunately, a region of valid solutions does not always exist. When a valid region does not exist, it is not clear if it is possible to modify the algorithm such that a solution does exist, and if so, how. Secondly, the algorithm for performing the geometric analysis is computationally expensive. This could be a serious impediment to real-time control.

D. Torque Translation Algorithm

An alternative method of specifying actuator excitations based upon commanded torques will be presented briefly here. A complete description of the torque translation algorithm will be presented in future publications, along with experimental results of trajectory control experiments.¹³ This algorithm is based on characterization of passive actuator capabilities based on accessible manipulator state information.

As stated earlier, the problem of specifying four actuator torques from only two components of commanded torque is mathematically underconstrained. A direct consequence of this fact is that the four passive actuators have overlapping capabilities. Therefore, in most cases, it will not be necessary to utilize all four actuators at all times.

The technique is based upon exploiting the specific nature of the passivity constraints. In the case of P-TER, passivity primarily limits the *direction* in which torques can be applied at any given time. The achievable

torque directions for each actuator are dependent upon the relative velocities of the friction surfaces for each actuator. For example, for brakes, only torques that oppose the existing motion of its corresponding link can be generated. For clutches, only torques that oppose the relative motion between the two links can be generated. In the case that there is no existing motion associated with a particular actuator, that actuator can only apply torques that oppose any impending motion.

For an N degree-of-freedom device, these passivity constraints can be visualized in N-space. At any instant in time, the capability of an actuator is represented by a vector with a fixed direction and variable magnitude in N-space. Likewise, the commanded torque is represented by a single vector in N-space. For the task of specifying actuator torques, there are only two primary cases:

- The commanded torque vector lies *within* the N-dimensional volume spanned by the actuator vectors.
- The commanded torque vector is *outside* the N-dimensional volume spanned by the actuator vectors.

In the first case, the controller can use a subset of up to N actuator vectors to construct the vector of commanded torques. All other actuator's excitations are set to zero. Constructing the N-dimension torque vector with N basis vectors is straightforward. The choice of the N actuators to use as basis vectors is arbitrary and can be optimized for the particular application.

In the second case, the passivity constraints state that there is no exact solution. However, in this case, the best approximation will be to use the projection of the torque vector onto the nearest boundary of the N-dimensional volume of achievable actuator torques. This yields a well defined actuation strategy even in the case of no exact solution.

V. CONCLUSIONS

The development of the experimental test bed is a major contribution of this research. Although numerous passive mechanisms exist, P-TER is unique in several aspects. P-TER utilizes computer controlled brakes and clutches as passive actuators. These actuators allow a full range of resistance to motion from "almost" frictionless motion to completely locked joints. In addition, the overlapping capabilities of the actuators provide enhanced control capabilities for a passive device.

The investigation of control algorithms and implications given here should be valuable to future work in the area of haptic displays and passive robotics in particular. The programmable damping formulation may be useful, especially where relationships between interaction forces and velocities are of primary concern. Similar work has shown that control of force-velocity relationships may provide "corrective action" during task execution.

The most important contribution may be the groundwork for the torque translation algorithm. The algorithm "translates" general (active) controller commands into commands achievable by the passive actuators of the device. The algorithm uses manipulator state information with knowledge of the actuator capabilities to choose a favorable passive actuation strategy in all cases. The torque translator introduced here has been formulated specifically for P-TER, but the foundations of its development should be widely applicable.

ACKNOWLEDGMENTS

This research has been partially supported by NSF Research Grant IRI-9526322.

REFERENCES

1. W. J. Book, R. A. Charles, H. T. Davis, and M. Gomes, "The Concept and Implementation of Passive Trajectory Enhancing Robot," *Proc. of the ASME International Mechanical Engineering Conference and Exhibition*, 1996.
2. B. Preising, T. C. Hsia, and B. Mittelstadt, "A Literature Review: Robot in Medicine," *IEEE Engineering in Medicine and Biology*, pp. 13-22, June 1993.
3. A. H. Soni, M. R. Gudvalli, W. A. Herndon, and H. A. Sullivan, "Application of Passive Robot in Spine Surgery," *Proc. IEEE Conference Engineering Biology and Med. Society*, pp. 1186-1191, 1986.
4. N. Hogan, "Impedance Control: An Approach to Manipulation," Parts I-III, *ASME Journal of Dynamic Systems, Measurement, and Control*, Vol. 107, No. 1, pp. 1-24, March 1985.
5. A. Goswami and M. A. Peshkin, "Mechanical Computation for Passive Force Control," *Proc. IEEE Conference on Robotics and Automation*, pp. 476-483, 1993.
6. J. M. Shimmels and M. A. Peshkin, "Admittance Matrix Design for Force Guided Assembly", pp. 213-217, *IEEE Transactions on Robotics and Automation*, Vol. 8, No. 2, April 1992.
7. J. M. Shimmels and M. A. Peshkin, "Force Assembly with Friction", pp. 465 - 479, *IEEE Transactions on Robotics and Automation*, Vol. 10, No. 4, August 1994.
8. J. D. Chapel and R. Su, "Coupled Stability Characteristics of Nearly Passive Robots," *Proc. of IEEE International Conference on Robotics and Automation*, pp. 1342-1347, 1992.
9. P. Y. Li and R. Horowitz, "Passive Velocity Field Control of Mechanical Manipulators," *Proc. of the IEEE International Conference on Robotics and Automation*, pp. 2764-2770, 1995.
10. K. F. Laurin-Kovitz, J. E. Colgate, and S. D. R. Carnes, "Design of Components for Programmable Passive Impedance," *Proc. of IEEE International Conference on Robotics and Automation*, pp. 1476-1481, 1991.
11. M. Peshkin, J. E. Colgate, and C. Moore, "Passive Robots and Haptic Displays Based on Nonholonomic Elements," *Proc. of the IEEE International Conference on Robotics and Automation*, pp. 551-556, April 1996.
12. R. A. Charles, "The Development of the Passive Trajectory Enhancing Robot," M.S. Thesis School of Mechanical Engineering, Georgia Institute of Technology, March 1994.
13. H. T. Davis and W. J. Book, "Torque Control of a Redundantly Actuated Passive Manipulator," submitted to *American Control Conference* 1997.