

*Preliminary Risk Assessment
of the Mexican Spotted Owl
under a Spatially-Weighted Foraging Regime
at the Los Alamos National Laboratory*

RECEIVED

APR 23 1997

OSTI



Los Alamos
NATIONAL LABORATORY

Los Alamos National Laboratory is operated by the University of California for the United States Department of Energy under contract W-7405-ENG-36.

Edited by Hector Hinojosa, Group CIC-1

Cover photo: A night-hunting Mexican spotted owl capturing prey. (Corel, Inc.)

*This work was supported by the U.S. Department of Energy,
Office of Environmental Management.*

An Affirmative Action/Equal Opportunity Employer

This report was prepared as an account of work sponsored by an agency of the United States Government. Neither The Regents of the University of California, the United States Government nor any agency thereof, nor any of their employees, makes any warranty, express or implied, or assumes any legal liability or responsibility for the accuracy, completeness, or usefulness of any information, apparatus, product, or process disclosed, or represents that its use would not infringe privately owned rights. Reference herein to any specific commercial product, process, or service by trade name, trademark, manufacturer, or otherwise, does not necessarily constitute or imply its endorsement, recommendation, or favoring by The Regents of the University of California, the United States Government, or any agency thereof. The views and opinions of authors expressed herein do not necessarily state or reflect those of The Regents of the University of California, the United States Government, or any agency thereof. Los Alamos National Laboratory strongly supports academic freedom and a researcher's right to publish; as an institution, however, the Laboratory does not endorse the viewpoint of a publication or guarantee its technical correctness.

*Preliminary Risk Assessment
of the Mexican Spotted Owl
under a Spatially-Weighted Foraging Regime
at the Los Alamos National Laboratory*

Anthony F. Gallegos,
Gilbert J. Gonzales**,
Kathryn D. Bennett†, and
Lawrence E. Pratt‡*

DISTRIBUTION OF THIS DOCUMENT IS UNLIMITED

ph

*Senior Radioecologist, Environmental Sciences Group

**Ecologist, Ecology Group

†Field Biologist, Ecology Group

‡Graduate Research Assistant, Ecology Group

MASTER

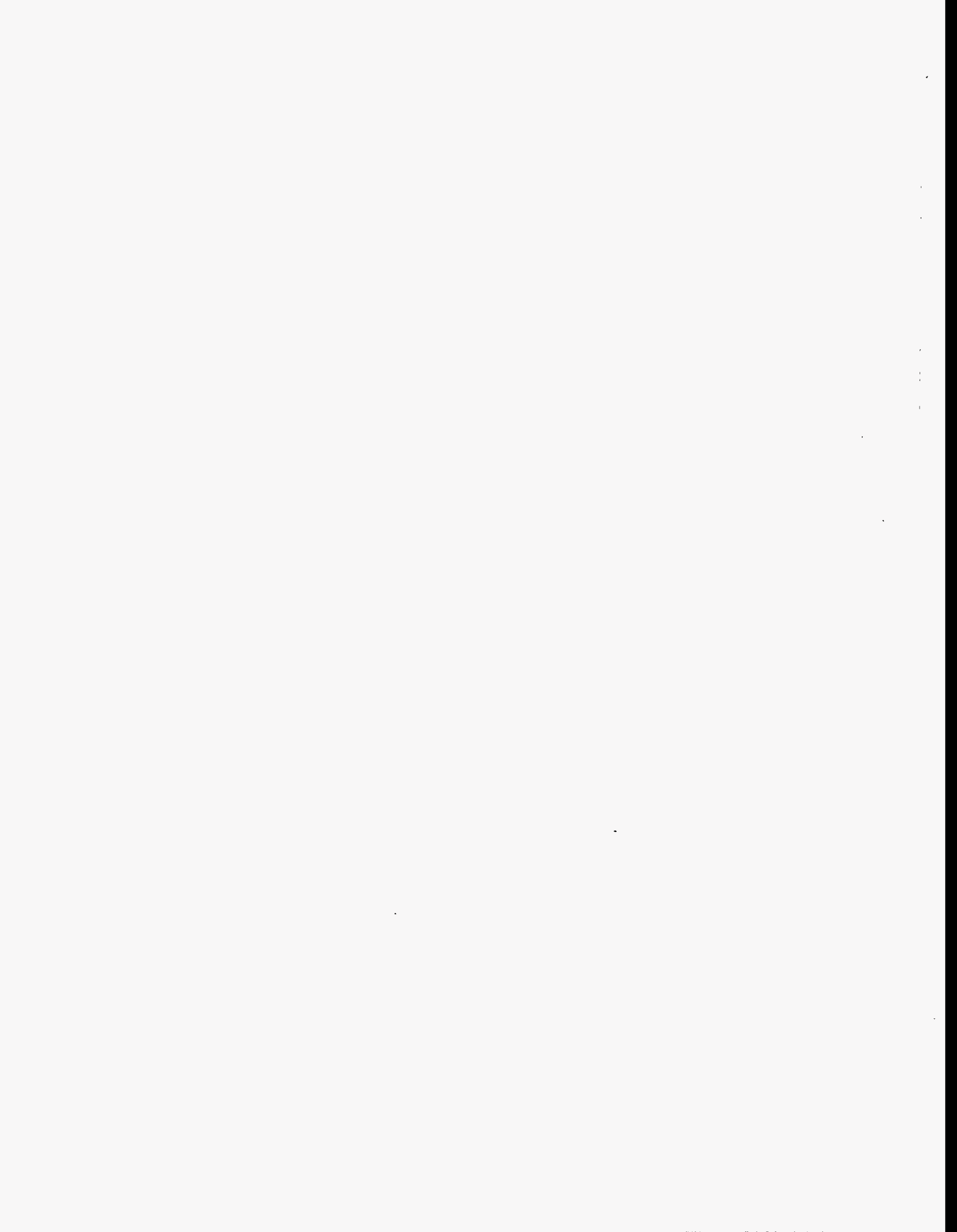

CONTENTS

LIST OF ACRONYMS.....	VII
ABSTRACT	1
1.0 INTRODUCTION.....	1
2.0 METHODS	2
2.1 BACKGROUND	2
2.2 DEVELOPMENT OF ECOLOGICAL EXPOSURE UNITS.....	2
2.3 DATA COMPILATION PROCEDURE.....	7
2.4 PRELIMINARY LIST OF CONTAMINANTS OF POTENTIAL ECOLOGICAL CONCERN.....	8
2.5 FOOD WEB DEFINITION	9
2.6 PATHWAYS OF EXPOSURE	10
2.7 RISK CALCULATION	10
2.7.1 Nonradionuclide Contaminants.....	10
2.7.2 Radionuclides	11
2.7.3 Fraction of Food Intake as Soil, F_s	11
2.7.4 Reference Doses.....	12
2.7.4.1 Nonradionuclides	12
2.7.4.2 Radionuclides.....	13
2.8 RISK SOURCES AND HAZARD VALUE TYPES	13
2.9 MODEL.....	14
2.9.1. Computer Code Software Development for Ecorisk Determination.....	14
2.9.1.1 Cumulative HQ Estimation Method using ECORSK4.....	18
2.9.1.2 Daily Food Consumption (Food).....	18
2.9.1.3 Soil Intake Fraction (Soil f) and Body Weight (BODWT)	19
2.9.1.4 Occupancy Factor (Occup).....	19
2.9.2 ECORSK4 Model Operation Strategies	19
2.9.2.1 Nest Site Establishment.....	20
2.9.2.2 Model Selection of Foraging Area (Home Range)	20
2.9.2.3 Identification of Contaminated Grid Cells in the HR for a Given Nest Site	20
2.9.2.4 HQ Estimation Procedure.....	20
2.9.3 Model Output.....	22
2.9.3.1 Demonstrated 3-d Graphics of HIs by Nest Site	22
2.9.3.2 Demonstrated 3-d Graphics of Total HQs by COPEC	22
2.10 STATISTICAL ANALYSES	22
2.10.1 Simple Distribution.....	22
2.10.2 Hypothesis Testing.....	22
3.0 RESULTS.....	26
3.1 UNADJUSTED MEAN HAZARD INDEX.....	26
3.2 HAZARD INDEX DISTRIBUTION.....	26
4.0 DISCUSSION.....	29
4.1 MANAGEMENT USE OF RESULTS	29
4.2 LIMITATIONS AND UNCERTAINTY.....	29

5.0 CONCLUSIONS.....32
ACKNOWLEDGMENTS33
LITERATURE CITED33
APPENDIX.....39

List of Acronyms

BAF	Bioaccumulation factor
BODWT	Body Weight
COPEC	Contaminant of Potential Ecological Concern
DARHT	Dual Axis Radiographic Hydrodynamic Test Facility
EES-15	Earth and Environmental Sciences Division, Environmental Sciences Group
EEU	Ecological Exposure Unit
EIS	Environmental Impact Statement
EPA	U.S. Environmental Protection Agency
ESH-20	Environmental, Safety and Health Division, Ecology Group
ESRI	Environmental Systems Research Institute
FIMAD	Facility for Information Management, Analysis, and Display
F _i	Fraction of Food Intake as Soil
GIS	Geographic Information System
HI	Hazard Index
HMP	Habitat Management Plan
HQ	Hazard Quotient
HR	Home Range
IAEA	International Atomic Energy Agency
LANL	Los Alamos National Laboratory
LOAEL	Lowest Observed Adverse Effects Level
NOAEL	No Observed Adverse Effects Level
RfD	Reference Dose (e.g., NOAEL)
SAL	Screening Action Level (soil)
SC	Soil Concentration
TA	Technical Area
TES	Threatened and Endangered Species
UF	Uncertainty Factor
UTL	Upper Tolerance Level (e.g., 95 th percentile)

Preliminary Risk Assessment of the Mexican Spotted Owl under a Spatially-Weighted Foraging Regime at the Los Alamos National Laboratory

Anthony F. Gallegos, Gilbert J. Gonzales, Kathryn D. Bennett, and Lawrence E. Pratt

Abstract

The Record of Decision on the Dual Axis Radiographic Hydrodynamic Test Facility at the Los Alamos National Laboratory requires that the Department of Energy takes special precautions to protect the Mexican Spotted Owl (*Strix occidentalis lucida*). In order to do so, risk to the owl presented by radiological and nonradiological contaminants must be estimated. A preliminary risk assessment on the Mexican Spotted Owl in two Ecological Exposure Units (EEUs) was performed using a modified Environmental Protection Agency Quotient method, the FORTRAN model ECORSK4, and a geographic information system. Estimated doses to the owl under a spatially-weighted foraging regime were compared against toxicological reference doses generating hazard indices (HIs) and hazard quotients (HQs) for three risk source types. The average HI was 0.20 for EEU-21 and 0.0015 for EEU-40. Under the risk parameter assumptions made, hazard quotient results indicated no unacceptable risk to the owl, including a measure of cumulative effects from multiple contaminants that assumes a linear additive toxicity type. An HI of 1.0 was used as the evaluative criteria for determining the acceptability of risk. This value was exceeded (1.06) in only one of 200 simulated potential nest sites. Cesium-137, Ni, ²³⁹Pu, Al and ²³⁴U were among the constituents with the highest partial HQs. Improving model realism by weighting simulated owl foraging based on distance from potential nest sites decreased the estimated risk by 72% (0.5 HI units) for EEU-21 and by 97.6% (6.3E-02 HI units) for EEU-40. Information on risk by specific geographical location was generated, which can be used to manage contaminated areas, owl habitat, facility siting, and/or facility operations in order to maintain risk from contaminants at acceptably low levels.

1.0 Introduction

The Record of Decision on the Dual Axis Radiographic Hydrodynamic Test Facility (DARHT) Environmental Impact Statement (EIS) mandates that the Department of Energy takes special precautions to protect the Mexican spotted owl (*Strix occidentalis lucida*) at the Los Alamos National Laboratory (LANL) (DOE 1996, DOE 1995). In order to do so, risks to the owl presented by radiological and nonradiological contaminants must be estimated. This report presents the results of a preliminary risk assessment on the Mexican spotted owl and is a component of a Habitat Management Plan

(HMP) on threatened and endangered plant and animal species (TES) at LANL. The assessment is regulated by the US Fish and Wildlife Service as the statutory authority of the Endangered Species Act of 1973.

The general approach for performing the assessment was to make a quantitative appraisal of the potential effects that soil contaminants might have on the owl when introduced through soil ingestion pathways using a modified Quotient Method described by the US Environmental Protection Agency (EPA) (EPA 1996, EPA 1992a). The methodology generally involved comparing calculated doses to the owl against reference

doses (RfDs) either provided in or calculated from the scientific literature. Two Mexican spotted owl potential habitats at LANL were evaluated. Each consisted of a predetermined potential nesting/roosting zone and a calculated foraging area. Collectively the nesting/roosting zone and the foraging area comprised a Mexican spotted owl "ecological exposure unit" (EEU) (Figure 1).

2.0 Methods

2.1 Background

The development of methods for estimating the effects of toxic substances on animal and plant populations at LANL, with particular interest in ecosystem dynamics, is an ongoing program at this laboratory. Recent efforts to standardize the estimation methods have been published for LANL by the Environmental Science Group (EES-15) and are used as a guide for this study (Ferenbaugh et al. 1996). The EES-15 methodology employs a tiered approach whereby conservative risk screening is conducted first, and then successive stages of progressively more complex risk assessments are performed in subsequent "tiers". The HMP risk component for a TES does not include an initial conservative screening of contaminated sites, because, for individual screenings, unlike the proposed methodology of EES-15, the sites are not grouped into potential release sites, but into sampling locations that have identifiable north-south (N-S) and east-west (E-W) coordinates obtained from a geographic information system (GIS) through LANL's Facility for Information, Management, and Display (FIMAD) database. This study is considered a "Tier 2", or preliminary risk assessment, and the level of detail and complexity of risk parameters are commensurate with the tiered approach.

2.2 Development of Ecological Exposure Units

An EEU is a unit defined by the biology of a species or group, within which an ecological risk assessment is conducted (Ferenbaugh et al. 1996). As mentioned, each EEU for Mexican spotted owl consists of a predetermined potential nesting/roosting

zone (Johnson 1993) and a calculated foraging area.

Potential nesting/roosting zones were based on work performed by Johnson (1993) in which he developed a topographic model to rate the physical potential of habitat for breeding spotted owls. Topographic data of United States Geological Survey 1-degree Digital Elevation Models provided the input for modeling the potential habitat. Historical owl locations were extracted from a New Mexico Department of Game and Fish database prepared by the New Mexico Natural Heritage Program. The model was developed by examining topographic characteristics of owl locations and random locations to find a scalar function of topography that quantitatively separated inhabited areas from random locations. The database included 1,383 records of historical reports and United States Forest Service inventory and monitoring daytime follow up field work through 1991. See Johnson (1993) for more detail on the methodology for identifying potential owl nesting habitat.

For defining the foraging area or home range (HR) of the owl, reviews were made of the draft "Recovery Plan for the Mexican Spotted Owl" (Block et al. 1995) and other literature including reports by Allen and Brewer 1986, Forsman and Meslow 1985, and Marcot and Holthausen 1987 (see Gonzales et al. 1996). Home range varies considerably by geographic variation and local experts indicate that HR is considerably smaller in the southern Rocky Mountains than in other areas. Therefore the decision was made to estimate HR, or foraging area, according to Peters (1993) as based on body weight because this resulted in an HR that is closer to estimates of local experts and because this would provide a consistent optional method for estimating HRs for additional species to be assessed in the future. Nevertheless, the model (described later) used for calculating estimated risk was developed with the flexibility to entertain any desired HR.

Thus, the foraging area around a specific nesting site or HR was estimated according to Peters (1993) for various animal types as

$$\begin{array}{ll} \text{HR} = 1.39 \times \text{BODWT}^{1.37} & \text{mammal, carnivore, (1a)} \\ = 0.032 \times \text{BODWT} & \text{mammal, herbivore, (1b)} \end{array}$$

DISCLAIMER

**Portions of this document may be illegible
in electronic image products. Images are
produced from the best available original
document.**

	= (Eq. 1a + Eq. 1b)/2	mammal, omnivore	(1c)*
HR	= $8.3 \times \text{BODWT}^{1.37}$	bird, carnivore,	(1d)
	= $0.026 \times \text{BODWT}^{1.71}$	bird, herbivore,	(1e)
	= (Eq. 1d + Eq. 1e)/2	bird, omnivore,	(1f)*
HR	= $0.12 \times \text{BODWT}^{0.95}$	reptiles and amphibians,	(1g)

where

HR = animal home range, km² and
BODWT = animal body weight, kgfwt.

* Estimated from scatter plot data of Peters (1993) for all 3 types of foragers.

As a result of employing the Peters (1993) method for calculating HR, the maximum foraging area and the extreme boundaries of each owl EEU were established by mapping an area that was 3,000 ft from the extreme-most north, south, west, and east boundary of the nesting/roosting zone. The resultant EEUs are shown in Figures 2, 3. "EEU-21" includes foraging and nesting/roosting areas that center around Los Alamos Canyon and encompass all or portions of LANL Technical Areas (TAs) 02, 05, 21, 35, 53, 60, 61, and 73. "EEU-40" includes foraging and nesting/roosting areas that center around Pajarito Canyon and Cañon de Valle and encompass all or portions of LANL TAs 06, 09, 11, 14, 15, 16, 22, 35, 36, 37, 39, 40, 46, 48, 49, 50, 52, 55, 63, 64, 66, and 67.

Each EEU was mapped using a GIS and the GIS software ARC/INFO. ARC/INFO is a GIS software developed by Environmental Systems Research Institute, Inc. (ESRI 1989).

GIS was used to create spatial data sets, combine information from different spatial data sets, generate a spatial grid, and produce maps. The spatial extent of the nesting and roosting spotted owl habitat was digitized into ARC/INFO to create a coverage (theme or layer). This habitat was assigned an attribute coverage factor (map code value). The modeling also required additional coverages to be developed, a grid set, and a forage habitat coverage.

More specifically, a grid was developed that would encompass the spatial extent needed for the modeling activity. In ARC/INFO, a grid was created using the command GENERATE with the fishnet

option. Adequate potential release site areal definition was not available for use in the risk estimation method to be described, therefore an alternative subunit area definition was sought. The requirements for grid size were that sufficient grid cell density was achieved to allow accurate development of spatial risk estimates within the limits of available personal computer capabilities and that presentation of spatial risk data did not appear to achieve greater resolution than is supported by the limitations of the GIS. Based on these criteria the chosen grid cell size was 100 ft by 100 ft. This assignment was assumed to be a conservative measure in most cases. However, as discussed in Section 2.9, provision is made for modification of the animal occupancy estimates if deemed necessary.

The ecological risk model required that each row and column of the grid was designated by a label. In addition, the coordinates of the center of each grid cell were needed. To accomplish this the *Basic* program listed in Table A-1 in the appendix was developed. These attributes were then added to the grid spatial data set.

The next coverage developed in ARC/INFO was the forage coverage. The forage coverage was created by selecting 30 grid cells above the maximum x, y extent of the owl habitat and 30 grid cells below the minimum x, y extent. The forage habitat was assigned an attribute factor of 1.

After these three coverages were made, additional information was needed that required combining coverages. First, the grid coverage was intersected with the sample location coverage to create a new coverage. This new coverage contained the sample locations as well as the grid attributes of row, column, and coordinates.

The three coverages were then combined to obtain one coverage with the attribute factor from the grid, the owl habitat, and the forage habitat. Separate map code values (attribute factors) were assigned for the owl nesting/roosting habitat, for the foraging habitat that was not within the owl nesting/roosting, and for the grid that was not within either (i.e., surrounding the foraging habitat). This was accomplished through a couple of coverage intersects and defining a

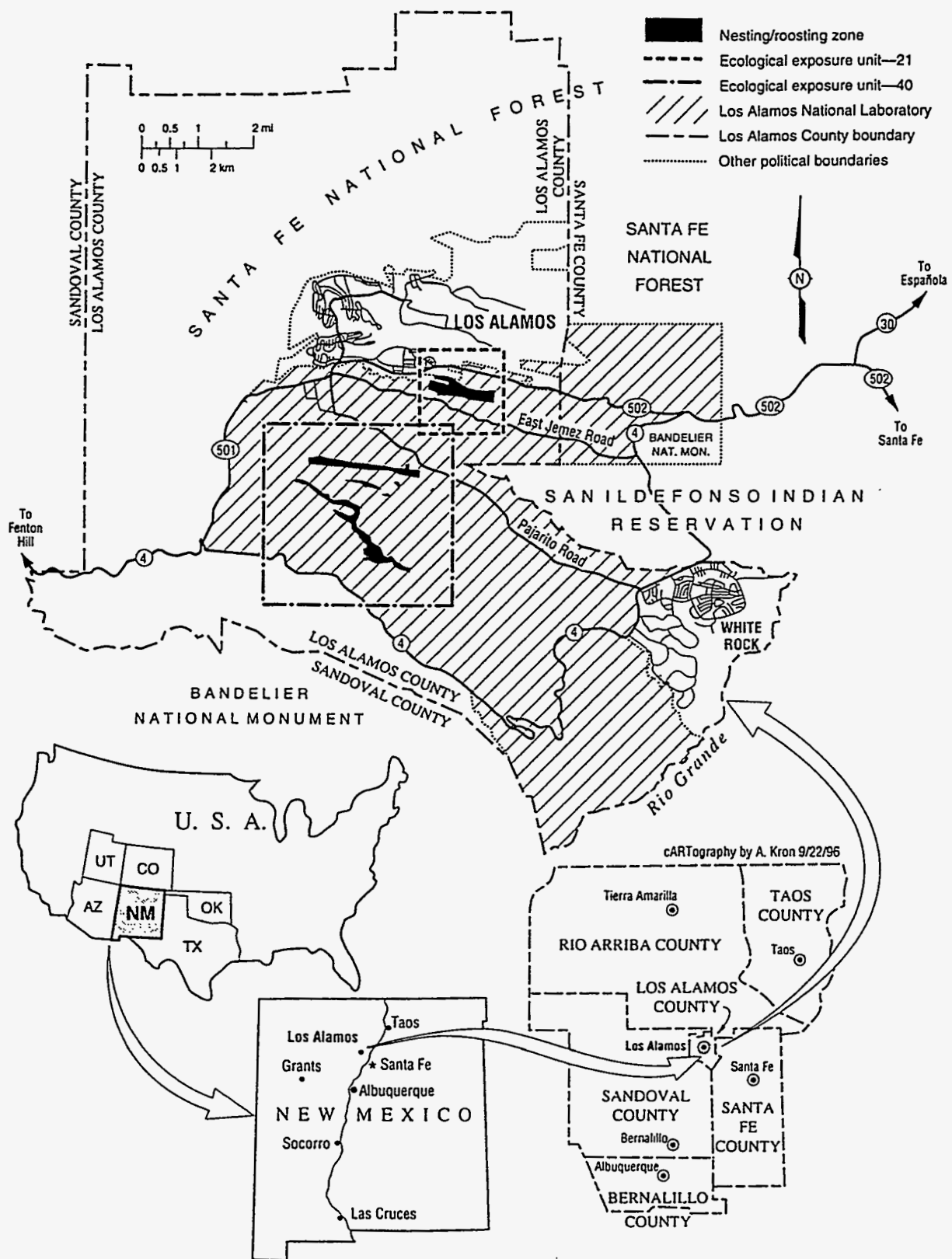

Figure 1. Location of Ecological Exposure Units (EEUs) for risk assessment of the Mexican spotted owl at the Los Alamos National Laboratory.

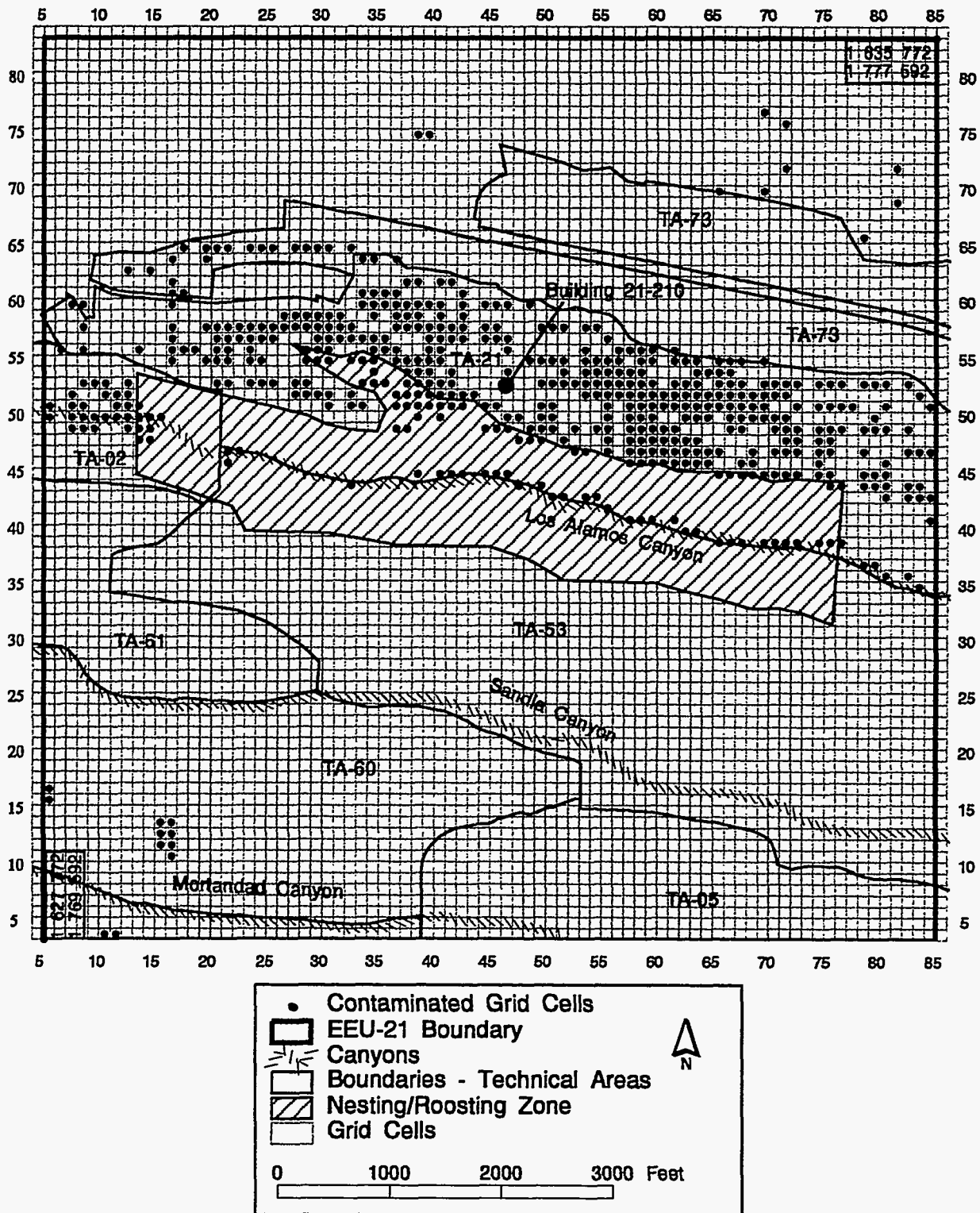

Figure 2. Ecological Exposure Unit 21 and location of sampled grid cells.

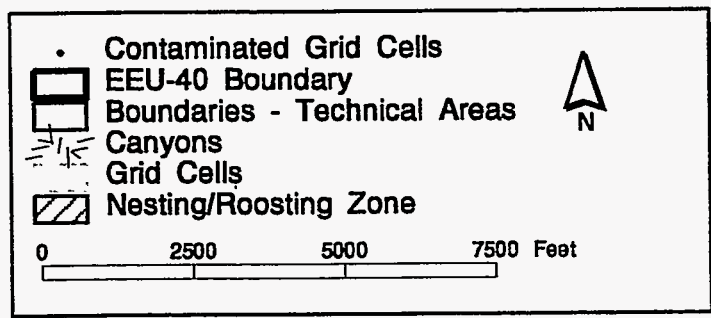
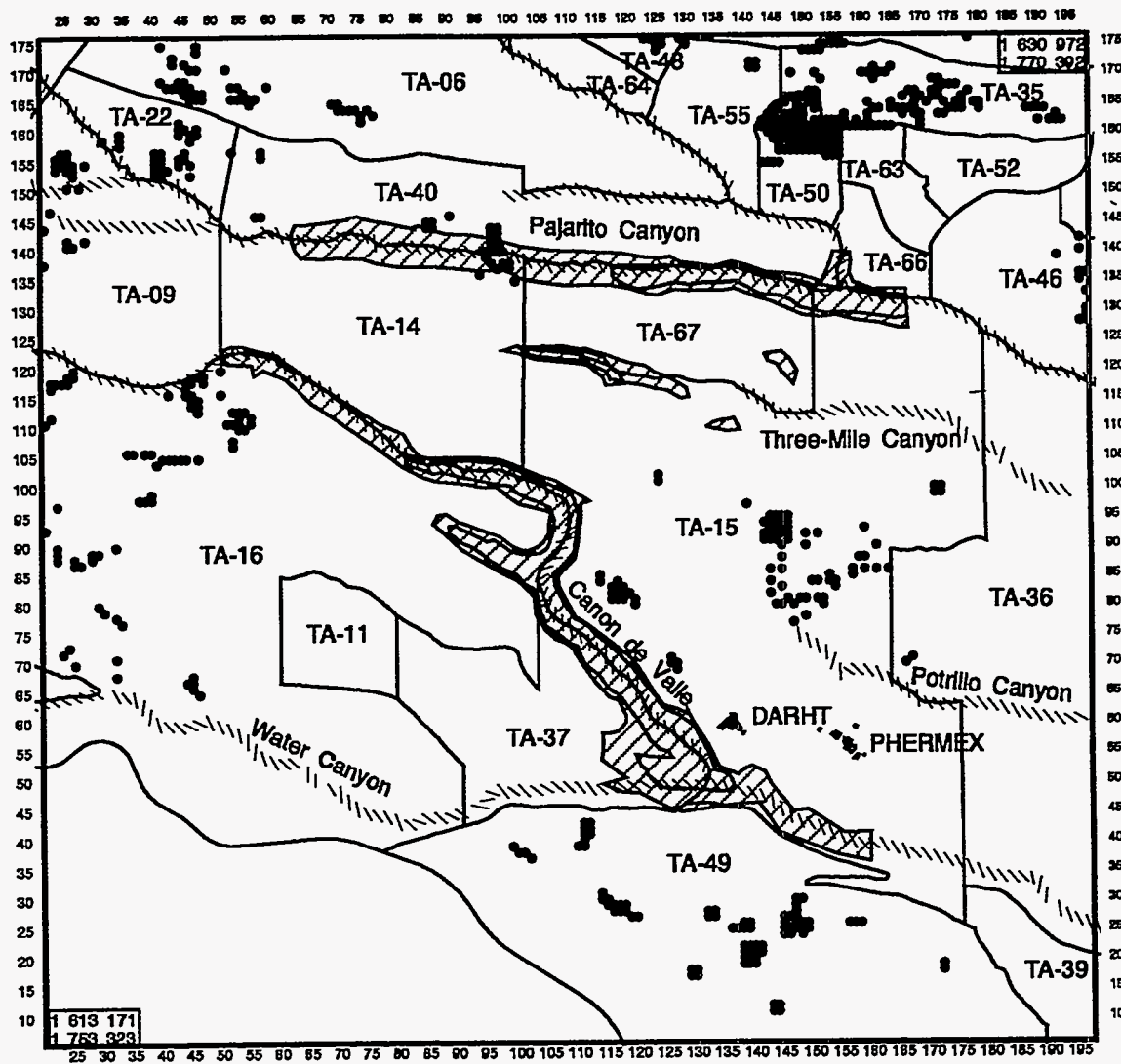

Figure 3. Ecological Exposure Unit 40 and location of sampled grid cells.

single new attribute factor.

When all coverages had been developed, maps were generated either in ARC/PLOT or ARC/INFO or ArcView. ArcView is a desktop GIS for map display, production, and query. It was also developed by ESRI (1989).

2.3 Data Compilation Procedure

Data used for this risk assessment were collected for environmental restoration activities at LANL by sampling and analyzing soils for inorganic, organic, and radioactive contaminants. Analytical results from this sampling are maintained in an Oracle database by FIMAD. FIMAD data can be accessed through the command line Structured Query Language or through the graphical interface Databrowser. The data for the risk assessment component of the TES project was accessed primarily with the latter.

Soil sampling data are stored in several tables, depending on the attribute of the data, when the data was collected, and the field unit from which the data was collected. If a sample was taken before April 1, 1995, the results are stored in one of the "analytical_info" tables, and if a sample was taken after April 1, 1995, the results are stored in the "stage" tables.

The data for the TES project were compiled from the FIMAD database for each foraging area according to the following procedure:

- In order to determine which samples were relevant to the TES study, all FIMAD-identified sampling locations within each foraging area were identified graphically from a map showing all the sampling locations stored in FIMAD (see Figures 2 and 3).
 - Sampling locations were then linked to sample identification numbers and field units to determine where the analytical results would be stored.
 - Five FIMAD tables were queried for the analytical results:
 - analytical_info_fu01,
 - analytical_info_fu02,
 - analytical_info_fu03,
 - analytical_info, and
 - sample_request_header_stage (verified).
- The "analytical" tables contain data for the field units 1-5 gathered prior to April 1, 1995, and the "stage" table contains data for samples gathered after April 1, 1995. Analytical table data are quality assured prior to loading into FIMAD. Stage table data were submitted for special quality assurance review.
- As part of the query language, analytical results were screened to contain only samples with a beginning depth = "0". The data was then exported to a personal computer and modified further using Excel software.
 - All records were screened by "sample units", and those records not given in grams or kilograms were discarded. All remaining records were converted to mg/kg for organic elements and heavy metals or to pCi/g for radioactive elements, leaving only the surface soil sample data relevant to the TES study. Although higher quantities of contaminants have been found at intermediate soil depths than at shallow depths elsewhere at LANL (Gonzales and Newell 1996), their bioavailability to aboveground biota is unknown.
 - All sample values for records which were below the detection limits of the instrumentation used in the analysis were changed to zero.
 - Every sample record was assigned the appropriate cell (100 ft by 100 ft) of the grid covering the feeding area. The grid cells are labeled with the row and column in which they are found (see Figures 2 and 3).
 - Averages were calculated for each analyte within every grid cell containing at least one record of data. The "grid" was superimposed onto a map of sampling locations that were concentrated around preidentified "potential release sites". Sample locations were not scattered evenly throughout cells of the grid because generally more samples were taken where higher levels, greater variation, or larger spread of

contamination were expected. Consequently, some cell averages include the data from several samples, others include the data from only one sample, while still others have no analytical data.

Many models exist for assigning contaminant concentrations to unsampled points. Of these most assume continuity or gradation in contamination levels between sampling points (Clifford et al. 1995). In this study the large HR of the Mexican spotted owl resulted in the creation of such large EEUs that the contaminant distribution was very heterogeneous, not continuous. Although there are extrapolation methods that do not presume continuity, they also were deemed inappropriate for the level of risk assessment applied in this study. For example, use of the Thiessen polygon technique (ESRI 1989) would have applied a "nearest neighbor" approach to assigning each and every spatial sample value to its own polygon such that any location within the polygon is closer to the polygon's sample location than to any other sample point (Clifford et al. 1995). Applied to this study, the Thiessen technique would likely more accurately represent soil concentrations in areas of high sample number density but would overestimate soil concentrations in areas of low or no sample densities. Since the areas of low or no sampling are vast within the EEUs, and it is assumed with some degree of confidence that contaminant concentrations in these unsampled areas are actually relatively low, soil concentration estimates for each EEU as a whole made using the Thiessen technique would be overestimated. This is undesirable because the location of sampling is already biased toward areas known or likely to contain or concentrate contaminants. Thus while more sophisticated estimation techniques are available, they are not always appropriate. For the TES Habitat Management Project, spatial weighting will be more important for animals with small HRs where differences in contaminant concentrations between points of relatively small distance within a 100-ft² grid cell would have more of an impact. Such is likely the case for the New Mexico meadow jumping mouse (*Zapus hudsonius luteus*) and

the Jemez Mountains salamander (*Plethodon neomexicanus*) as examples.

Not all cells have analytical results for the same set of analytes, because the same analyses were not performed for all the "potential release sites" in the area. Lastly, an entire 100- by 100-ft area was assumed to contain an analyte concentration that was measured in as few as one sample. This would be considered a conservative assumption in many cases in which contamination is confined to an area less than 100 ft².

- The number of analytes with sample results was calculated for each cell.
- The grid cells were assigned the x- and y-coordinates calculated at the center of each cell.
- Mean "natural" (inorganics) or "regional" (radionuclides) soil background concentration values of analytes were assigned to each analyte within each grid cell, and zeros were assigned in the absence of a background value such as for organics. Sources of background values were Fresquez et al. (1996) and Longmire et al. (1996).
- RfDs, RfD adjustment factors, and occupancy factors (all discussed in a later section) were then assigned to each analyte within each grid cell.

The final data contained the fields: grid cell id, analyte, analyte code, analyte average (by grid cell), RfD, RfD adjustment factor, occupancy factor, background value, number of analytes per cell, x-coordinate, and y-coordinate. Finally, the fields were formatted as a database ("eeuinp.dat") for input to the model "ECORSK4".

2.4 Preliminary List of Contaminants of Potential Ecological Concern

Contaminants of potential ecological concern (COPECs) are those

- known to have been used or to be present in the EEU,
- to which receptors within the EEU are known to be sensitive,

- identified as of concern during any human health risk assessment conducted in the same area, and
- which warrant concern because of other factors such as toxicity, persistence, exposure potential, or food chain transfer (Ferenbaugh et al. 1996).

A preliminary list of COPECs for each EEU was generated by querying LANL's FIMAD database for surface layer soil analytical results. Any analyte listed in the FIMAD database for which no analytical detections were made in the entire EEU were not included in the list. A preliminary COPEC list for the two EEUs may be found in Tables A-5 and A-6 in the appendix. Contribution to risk by any given COPEC could be calculated, as discussed later, only if a RfD was available for that COPEC. The preliminary COPEC list for the Mexican spotted owl should ultimately be revised on the basis of its sensitivity, and whether complete pathways exist from the sources to the owl (Ferenbaugh et al. 1996).

2.5 Food Web Definition

The Mexican spotted owl is a first-order carnivore, feeds primarily at night (Forsman et al. 1984, Ganey 1988), and is known to consume woodrats (*Neotoma*), mice, voles (*Microtus*), cottontail rabbits (*Sylvilagus audubonii*), pocket gophers (*Thomomys bottae*), bats, other mammals, birds, reptiles, and insects (Ganey 1992). In Arizona, Ganey (1992) reported that woodrats, white-footed mice (*Peromyscus*), and voles constitute between 61 to 83% of prey on a frequency basis and between 59 to 88% on a biomass basis. Prey abundance was the main factor influencing selection of the rodent species. Based on data reported by Biggs (1995) for Los Alamos Canyon and Cañon de Valle, which are two of the three major canyons or portions of canyons that comprise the Mexican spotted owl potential habitat in this study, our estimates of weighted mean Mexican spotted owl diet on a composition basis are

- 46% *Peromyscus maniculatus* (deer mouse),

- 23% *Microtus longicaudus* (long-tailed vole),
- 14% *Peromyscus boylii* (brush mouse),
- 6.2% *Microtus montanus* (montane vole),
- 5.8% *Neotoma mexicana* (Mexican woodrat),
- 2% *Sorex vagrens* (vagrant shrew), and
- 4% insects and other.

These estimates are based solely on species abundance and can be considered the primary sources of food to the Mexican spotted owl at LANL until a more detailed food web is developed. Local experts are finding from pellet analysis that more birds and bats are consumed by the spotted owl than in the Arizona study on which our current estimate of diet is based. This could result in a lower F_s value (the fraction of food intake as soil), however, the study is not yet citable. Additional comments on specific prey to the owl are as follows. The deer mouse is strictly nocturnal (Bailey 1971), has been particularly noted as a dominant source of food to owls (Bailey 1971), and is most abundant in potential owl habitat at LANL. These facts support its identification as the likely dominant food source to the Mexican spotted owl at LANL. The abundance of the pocket gopher in Los Alamos County has been studied only on a limited basis because of its subsurface dwelling, but its occurrence at LANL has been documented (Bennett et al. 1996, Hakonson et al. 1982). The pocket gopher is known to interact significantly with soil contaminant distribution (Gonzales et al. 1995), however, it would not be expected to comprise a significant source of food to the owl because of its effectively continuous subterranean dwelling (Martin et al. 1961).

"Studies on cattle, sheep, and swine have shown that soil was the main source of exposure to environmental contaminants that included lead, PCBs [polychlorinated biphenyls], PBBs [polybrominated biphenyls], hexachlorobenzene, and DDT [dichloro diphenyl trichloroethane]" (Beyer et al. 1994). Because soil-ingestion rates of some wildlife species are estimated to be at least as great as those for domestic species, soil ingestion is an important route of

exposure to environmental contaminants for wildlife (Beyer et al. 1994). Wildlife may ingest amounts of soil while feeding that are substantial enough to constitute the main source of exposure to environmental contaminants.

2.6 Pathways of Exposure

A general conceptual model, based on Ferenbaugh et al. (1996), on pathways of contaminant exposure for the Mexican spotted owl are as follows:

- Primary Source of Contamination: Burial and outfalls;
- Primary Release Mechanisms: Burial and disposal of liquids through drains;
- Migration Pathways: Infiltration/sorption, biodegradation, organic volatilization, chemical reactions, and radioactive decay;
- Contact Pathways: Soil, volatiles/airborne dust, sediment, surface water;
- Intermediate Pathways: Transport from soil and soil contaminated vegetation to herbivores; and
- Primary Direct Exposure Route: Ingestion of soil-contaminated pellets as a first-order carnivore.

The preceding section on food webs established consumption of rodents as the main activity leading to potential contamination of the owl. This activity results in ingestion of soil-contaminated pellets as the dominant contaminant exposure pathway for the Mexican spotted owl. *Peromyscus* burrow into the near surface soil, which serves as the primary source of contamination. Based on abundance, they may serve as a more dominant exposure source than other prey.

2.7 Risk Calculation

Defined simplistically, ecological risk is the actual or potential effects of contaminants on flora and fauna. The measure used in this study to quantitatively appraise risk from contaminants to the Mexican spotted owl is the Quotient Method (EPA 1996, 1992)

whereby the Hazard Quotient (HQ) serves as the measure of potential risk.

2.7.1 Nonradionuclide Contaminants

The general form of the HQ used for the inorganic metal and organic contaminants is defined as

$$HQ = \text{Exposure (mg/kg-d)} / \text{RfD (mg/kg-d)}, \quad (2)$$

which is the ratio of exposure to a toxicity reference dose (RfD). When HQs for all contaminants are summed, it becomes a cumulative HQ and is termed Hazard Index (HI). With a threshold evaluative criteria of 1.0, HIs or HQs >1.0 are considered indicative of potentially unacceptable risk and, more conclusively, indicates the need to further assess risk to the species. A more detailed version of the formula above for computing the HI from multiple contaminated areas is

$$HI = [I \times F_s / BW] \sum_j O_j \sum_i C_{i,j} / \text{RfD}_j, \quad (3)$$

where

- HI = cumulative HQ over all contaminated grid cells and contaminants (COPECs),
- I = food intake, kgfwtd (3.94 by 10⁻² kgfwtd for owl)
- BW = body wt = 0.55 kgfwtd for owl,
- F_s = fraction of food intake as soil = 0.05,
- C_{i,j} = contaminant concentration in soil, mg/kg, for the *i*th contaminated grid cell, and the *j*th contaminant,
- RfD_j = receptor (owl) reference toxicological dose in mg/kg-d for the *j*th contaminant (Note: RfDs are discussed in the next section), and
- O_i = the fraction of time that an animal spends feeding in a given area.

Two cases of O_i were considered:

(I) "Unweighted foraging": the owl feeds within its calculated foraging area with no

regard to distance of any feeding area from a potential nest site; and

(II) "Weighted foraging": $O_i = e^{-r/400}$ (Johnson 1990), which estimates the relative probability of foraging as a function of radial distance in meters from the center of the foraging area. This results in almost 75% of the foraging within 1 km (Johnson 1990).

2.7.2 Radionuclides

Animal toxicity data such as no observed adverse effects levels (NOAELs) for radionuclides are largely unavailable, therefore an alternative method must be employed. Levels of radionuclides in soil called screening action levels (SALs) have been estimated for use as standards protective of humans. The SALs for radionuclides are estimated using the RESRAD code for radionuclide exposure to humans from elements of the food chain and non-food chain deposition processes (LANL 1993). The application of human standards to animals is conservative as discussed in section 2.7.4.2.

The HQ method applying human SALs to animals is similar to the HQ method involving ingested doses:

$$HQ = SC / SAL, \quad (4)$$

where

HQ = hazard quotient,
SC = soil concentration of radioactive
COPEC, pCi-COPEC/kg-soil, and
SAL = screening action level, pCi-
COPEC/kg-soil.

This study uses the above relationship for estimating radionuclide HQs, although they are additive with HQs developed from dose information. As with the nonradionuclides, two cases of foraging were considered for the radionuclides—unweighted foraging and weighted foraging.

2.7.3 Fraction of Food Intake as Soil, F_s

The fraction of food intake as soil, F_s , is currently an issue under consideration at LANL. The amount of soil consumed by

wildlife animals during feeding varies considerably depending on feeding strategy and type of food consumed (Beyer et al. 1994). According to Ferenbaugh et al. (1996), EPA guidance is that, for screening purposes, this parameter should be 50%, given that soil ingestion can range from less than 2% in some small birds and small mammals to approximately 100% in earthworms. LANL guidance is that the screening approach to this parameter may be examined to determine if the use of less conservative assumptions is justified in order to better reflect specific site and/or receptor conditions (Ferenbaugh et al. 1996). Beyer et al. (1994) conducted laboratory and field studies to estimate F_s in 28 herbivore or carnivore avian, mammal, and reptile species. Although the range in mean F_s for the avian species was <2–30%, all of the avian species evaluated either consume soil organisms as a dominant source of food or deliberately consume sediment for proper functioning of the gizzard. This is in contrast to the feeding habits of the Mexican spotted owl. Since the owl is a first-order carnivore, it would not have the exposure from soil ingestion that the avian species in the Beyer et al. study did. Also, for the two omnivores studied by Beyer et al. that prey on rodents like the owl, the red fox, and the raccoon, the average F_s was 6.1%. Of these two, only the diet of the red fox was predominantly carnivore, therefore its F_s of 2.8 is more applicable to the owl. For these reasons, the F_s value at the lower end of the range established by Beyer et al. (1994) is justified. This F_s value is also supported by a risk assessment on the burrowing owl that used an F_s value of 3% (Clifford et al. 1995). Therefore, a conservative F_s value of 5.0% was assumed for the Mexican spotted owl in this study. An F_s of about 3% may be used for the owl in future runs of the model.

A more detailed formula for computing the HQ is presented in a later section. Considering the estimated diet of the owl and studies cited by Beyer et al. 1994, ingestion of soil-contaminated pellets is likely the major source of potential contamination to the owl.

Upon randomly selecting a potential nest site within the defined nesting habitat of an EEU, the model ECORSK4 (described later in this report) developed a foraging area of

3.66 km² for the Mexican spotted owl and calculated a HQ for each COPEC within each 100- by 100-ft grid cell of the foraging area. The model repeated this process 99 times, thus there was a total of 100 repetitions. Contaminated grid cells "selected" during one repetition were "replaced" for possible selection during another repetition, but any given nest site was selected no more than once.

By assuming that the owl forages in noncontaminated as well as contaminated grid cells, our risk estimate lessens a source of error that Tiebout and Brugger (1995) conclude leads to overestimation of risk; i.e., the error associated with the implicit assumption normally made in the Quotient Method that birds remain in a contaminated zone. This also satisfies EPA guidance that "for many terrestrial animals, adjustments of exposure estimates may be needed to account for the possibility that all food obtained by a given animal may not be from the affected area" (EPA 1989). This is especially true for wide ranging animals such as the Mexican spotted owl.

2.7.4 Reference Doses

Little, if any, toxicological information on owls is available in the published literature. Esselink et al. (1995) found no indications of toxic effects on the barn owl (*Tyto alba guttata*) from Cd, Cu, Pb, Mn, or Fe at respective median levels of 1.09, 14.5, 0.94, 6.7, and 785 mg contaminant/kg drywt organ tissue for the kidney. Respective levels of these same metals in the liver that were associated with no toxic effects were 0.55, 29.2, 0.64, 9.8, and 1466 mg/kg. Respective tibia levels of 0.03, 1.80, 1.54, 2.60, and 45 mg/kg also were not associated with adverse effects.

2.7.4.1 Nonradionuclides

The RfDs chosen to use as contribution to the HQs for organic and metal COPECs were the chronic NOAELs in units of mg COPEC per kg body wt of the owl per day. The NOAELs and related information used are listed in Table A-2 in the appendix. In order of descending use, the manner in which NOAELs were compiled was

- 1) obtained directly from the scientific literature or from published databases (EPA 1992b, EPA 1993a, EPA 1993b, LANL 1994),
- 2) computed from chronic intake doses, and
- 3) computed from LD_{50s}.

Table A-2 identifies (1) the NOAELs used in this assessment; (2) references from which the NOAELs were derived; in some cases, (3) test species on which they are based; (4) the chemical form on which the NOAEL is based; (5) the toxicological test endpoint; and (6) comparison or alternative NOAELs or RfDs which could have been used. The NOAELs for the metal COPECs are based on avian test species. The NOAELs for the organic COPECs are based primarily on laboratory rats. NOAELs based on avian test species were identified and used for some of the organic COPECs, including the PCBs (aroclor), DDT and its metabolites, 2,4-D and dieldrin. No adjustments were made for extrapolating between phylogenetic lines of species. In human risk assessments, RfDs are typically adjusted (lowered) by a factor of 10 to account for (make conservative) the uncertainty of extrapolating RfDs within and between species. Because of a broader range of uncertainty in ecological risk, an uncertainty factor (UF) of 10 may be inadequate in ecological risk assessment (Calabrese and Baldwin 1993). Attempts to calculate extrapolations of RfDs have been made by some researchers, however, the bases vary from one researcher to another. For example, Sample et al. (1995) assumed that "smaller animals have higher metabolic rates and are usually more resistant to toxic chemicals because of more rapid rates of detoxification and that metabolism is proportional to body weight." Conversely, in a study of risk to vertebrates from pesticides, Tiebout and Brugger (1995) predicted that small-bodied insectivores faced the highest risk. Other possible sources of uncertainty that are not necessarily exclusive of each other include

- extrapolation of acute dose derived NOAELs to chronic responses,

- lowest observed adverse effect level (LOAEL) to NOAEL conversions,
- extrapolation of sensitive-test-species data to nonsensitive or "normal" life stages
- extrapolation of less-than-lifespan toxicological data to lifespan,
- time to achievement of contaminant steady-state in laboratory tests on which NOAELs are based, and
- laboratory to field extrapolation (Calabrese and Baldwin 1993).

Some of the above-listed factors have the potential to increase or decrease (under- or overestimate) toxicological values. Also, several instances of interdependence of UFs exist, therefore the assumption that these factors are independent in their application as UFs would likely lead to over-conservatism (Calabrese and Baldwin 1993). For these reasons, the authors believe that the collective amount of uncertainty originating from different sources is great enough and/or variable enough such that adjustment for such uncertainty would make the results unusable because of large total margins of introduced error.

2.7.4.2 Radionuclides

Ecological risk assessment at LANL sometimes does not address risk from radiation because of guidance of the International Atomic Energy Agency (IAEA) which says that if humans are adequately protected from the effects of radiation, then other organism populations are likely to be sufficiently protected (IAEA 1992). Under this assumption, if the results of human risk assessment(s) of the same contaminated areas as assessed for the Mexican spotted owl indicated that humans are adequately protected, the conclusion would be that populations of other organisms are adequately protected. The basis for this argument applied to the specifics of this study is that the human protection standard used by RESRAD (10 mrem/yr) is 3650 times more protective than the current IAEA animal protection criteria of about 100 mrad/day, assuming a biological quality factor of 1.0 or 185 times more protective, assuming a quality factor of 20. However, this theory

applies to populations of organisms and it is the individual Mexican spotted owl that is of concern in this study. More importantly, the theory has never been formally defended, "sufficient protection" has never been quantified nor the assumption proven and sensitivity to chronic radiation varies markedly among different taxa (IAEA 1992). For these reasons, TES are being assessed for potential impact from radionuclides.

Reproduction is the most radiation-sensitive biological process of concern for populations of organisms (IAEA 1992). Populations can remain healthy if only a small percentage of their population has their reproductive capability adversely impaired, but individuals cannot contribute to maintaining the health of a population if those individuals are irreparably damaged. Because RfDs for radionuclides in avian species were unavailable, human risk SALs, in mg of radionuclide per kg of soil were used in place of RfDs. A list of SALs used appears in Table A-2. Comparison with other models, sensitivity analyses, and verification analyses have demonstrated that the model which is used to calculate SALs is conservative (Wolbarst et al. 1996).

2.8 Risk Sources and Hazard Value Types

HQs were generated for three "Hazard Value Types" and three "Risk Sources" as follows:

Risk Sources

- Unadjusted risk - Contains the risk associated with Laboratory activities. Sources of HQ values include (i) HQs associated with contaminated grid cells, making no adjustment for background soil concentrations; and (ii) for grid cells where sampled COPEC soil concentrations result in Unadjusted HQs < Background HQs then Background HQs are entered.
- Background risk - Represents the risk associated with "natural" (nonradionuclides) and "regional" (radionuclides) mean background concentrations of COPECs. The mean natural or regional background soil

concentration is entered into the HQ formula for grid cells within a foraging area for which COPECs existed in the Unadjusted data set. Background levels were not entered for cells in which sampling has not been conducted because, for an animal with a large foraging area or HR, risk would be somewhat more proportional to area than to contamination levels. Clifford et al. (1995) have shown that assignment of background levels in Quotient Method risk estimation can be inconsequential in terms of final results.

- Contaminated Nest Site - Represents the unadjusted risk resulting from "situating" potential nest sites on contaminated grid cells within the "nesting/roosting" zone. There were 86 contaminated grid cells in the nesting habitat of EEU-21 out of a total of 743 nesting habitat grid cells and approximately 6400 total grid cells in the EEU. There were 16 contaminated grid cells in the nesting habitat of EEU-40 out of a total of 2,115 nesting habitat grid cells and approximately 30,600 total grid cells in the EEU.

Hazard Value Type

- HI (Hazard Index) - A sum of the HQs for all COPECs and all grid cells in a foraging area (or HR) averaged across the number of "repetitions".
- Mean Partial HQ \times Location (grid cell) - A sum of the HQs for all COPECs separated by location.
- Mean Partial HQ \times Location (grid cell) \times COPEC. A sum of the HQs separated by location (grid cell) and COPEC.

The most useful Hazard Value Type for conveying total risk is the Hazard Index (HI). For each of 100 randomly selected potential nest sites of the Mexican spotted owl and thus 100 repetitions, an HQ was calculated for a 3.66 km² HR, or foraging area, for each COPEC at each grid cell. The HI (or Mean Total HQ) sums the HQs for all COPECs and all grid cells in a foraging area and is an average of the 100 sets of data

(repetitions). Because the HI is the sum of the HQs for all COPECs, it serves as an index of cumulative effects from multiple contaminants and is the most conservative of the three Hazard Value Types.

2.9 Model

Some of the approach and methodology discussed earlier is presented again in this section to illustrate the method by which ECORSK4 develops the basic building blocks of the risk assessment.

2.9.1. Computer Code Software Development for Ecorisk Determination

A set of computer codes, one of which is called ECORSK4, written in FORTRAN 77 (Salford Software Limited 1994) with graphics capability (Interactive Software Services 1992), was developed to transform GIS-FIMAD into three-dimensional graphics and to utilize the data to perform a risk assessment of the Mexican spotted owl in a given EEU as illustrated in Figure 4. These codes integrate EEU, nesting area, HR data, and toxicological substances locations and concentrations within a given EEU to estimate risk to a specific animal and produce visual and statistical representations of these estimates.

The files obtained from ECORSK4 output can be further processed to produce more specific graphics via overlays onto the EEU mapping. For example, the 3-d plots in Figures 5a and 5b were produced from the gridxy.dat output file from the EEU-21 and EEU-40 runs of ECORSK4, whereas, the plots in Figures 6a and 6b for EEU-21 and EEU-40, respectively, were produced from specific nesting site information stored in the output file habit.dat. The user of the model also has the option of entering the variables such as the HR directly into the code. Examples of 3-d plot overlays and other plots involving other output files listed in Figure 4 will be illustrated in later sections of this report when the specific type of information is under discussion. Finally, the executable versions of these codes are MS-DOS PC versions which are transportable to other PCs (for PC users without Salford/Interactive software) by appropriate Run DBOS software that is provided by Salford for this

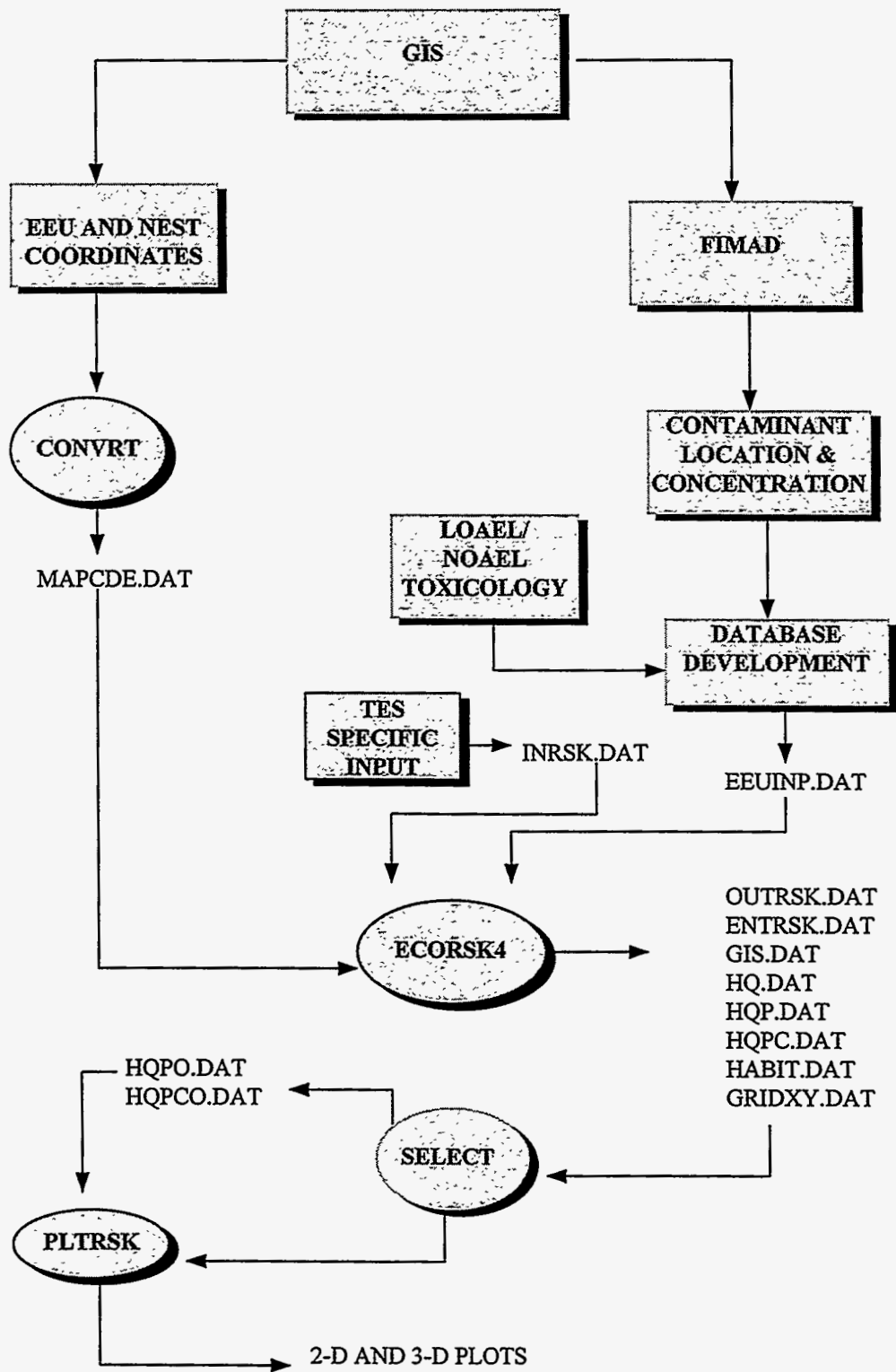

Figure 4. Schematic of strategy for integrating FORTRAN code with GIS and FIMAD data.

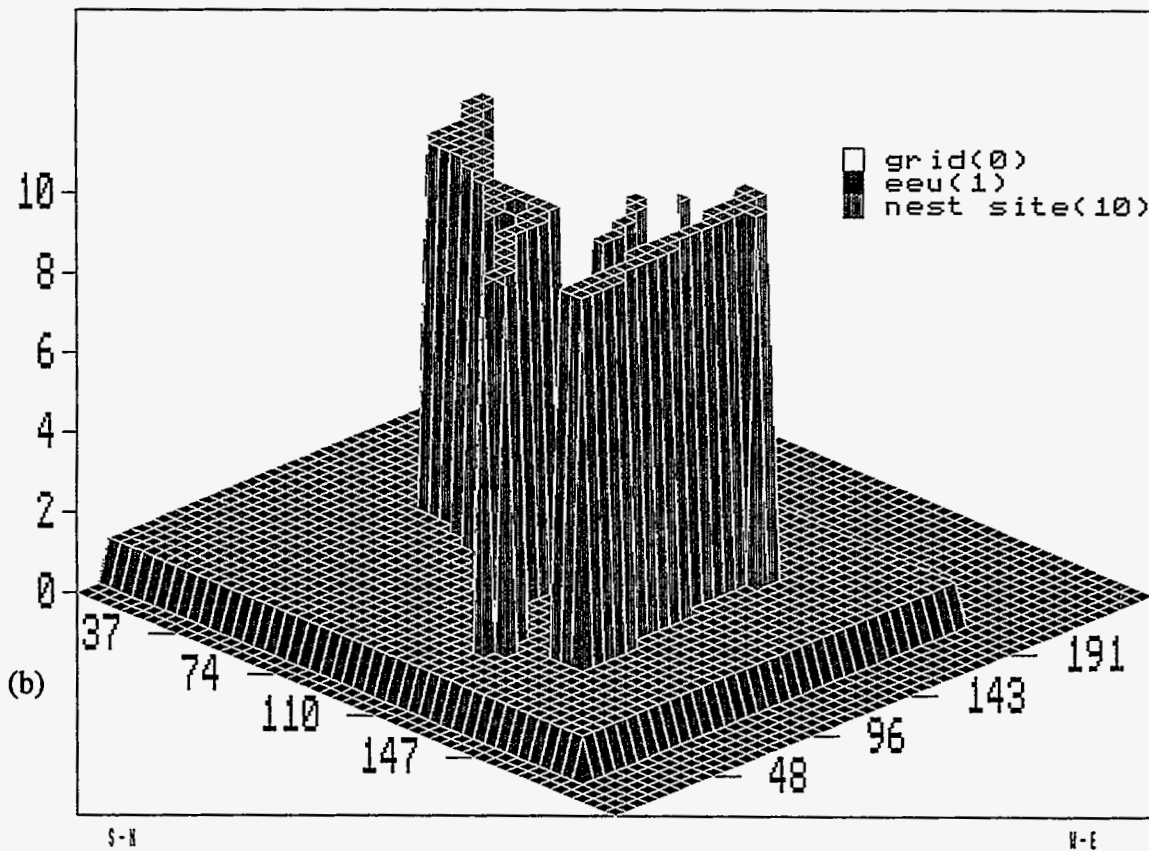
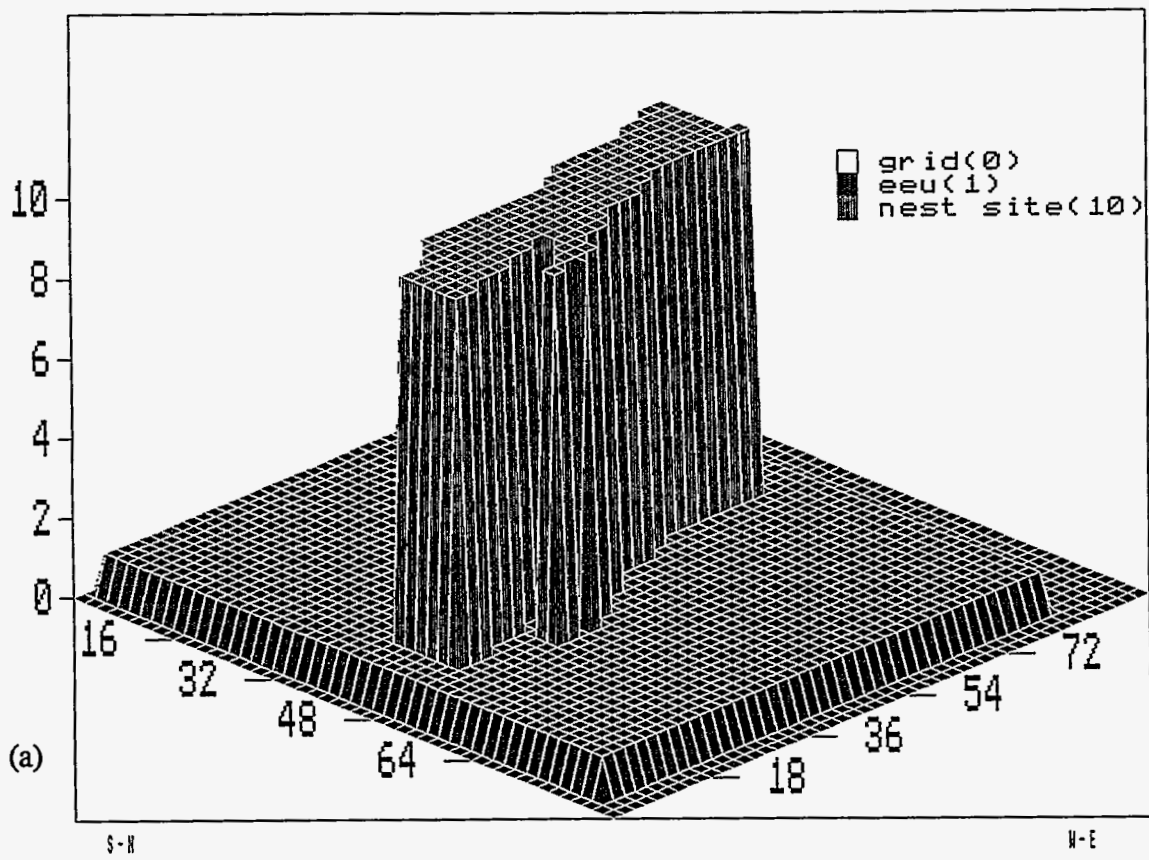

Figure 5. Demonstrated computer-simulated 3-d plots of Ecological Exposure Units (a) 21 and (b) 40, and respective nesting habitats for the Mexican spotted owl at the Los Alamos National Laboratory.

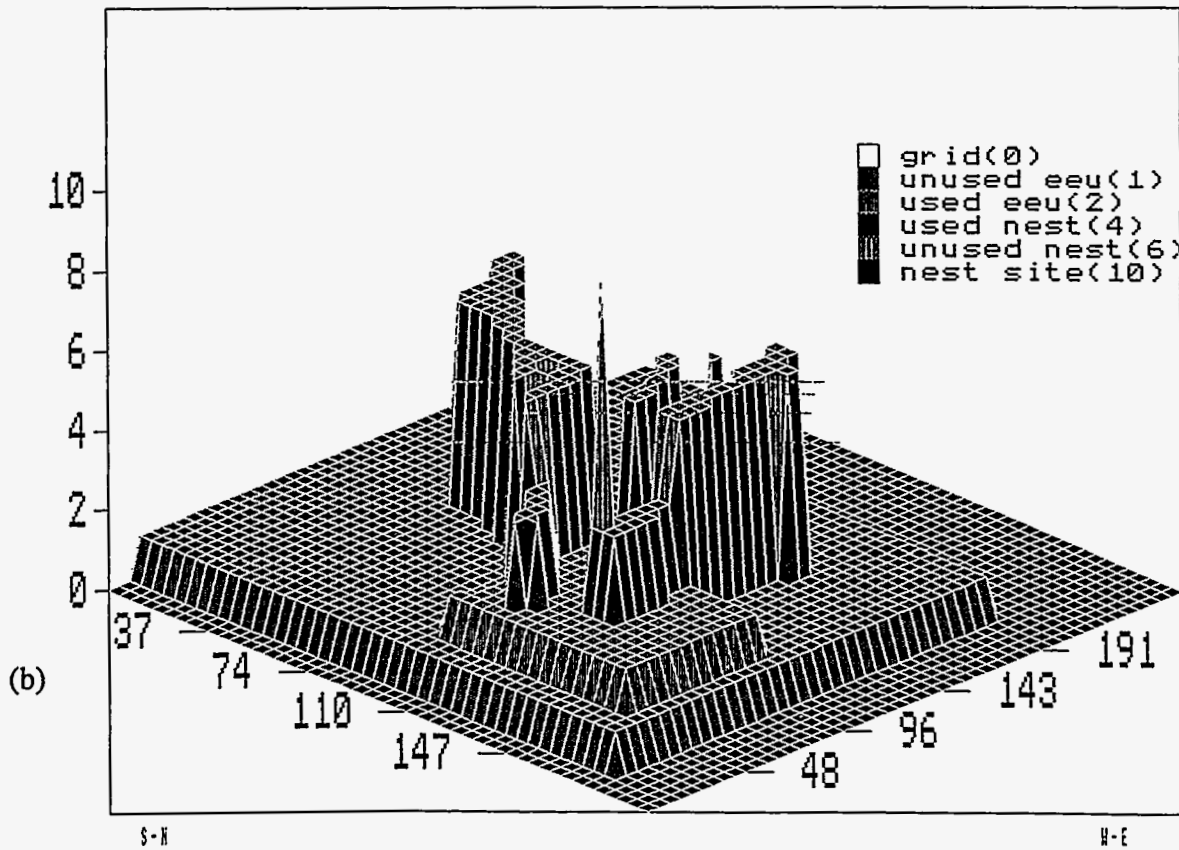
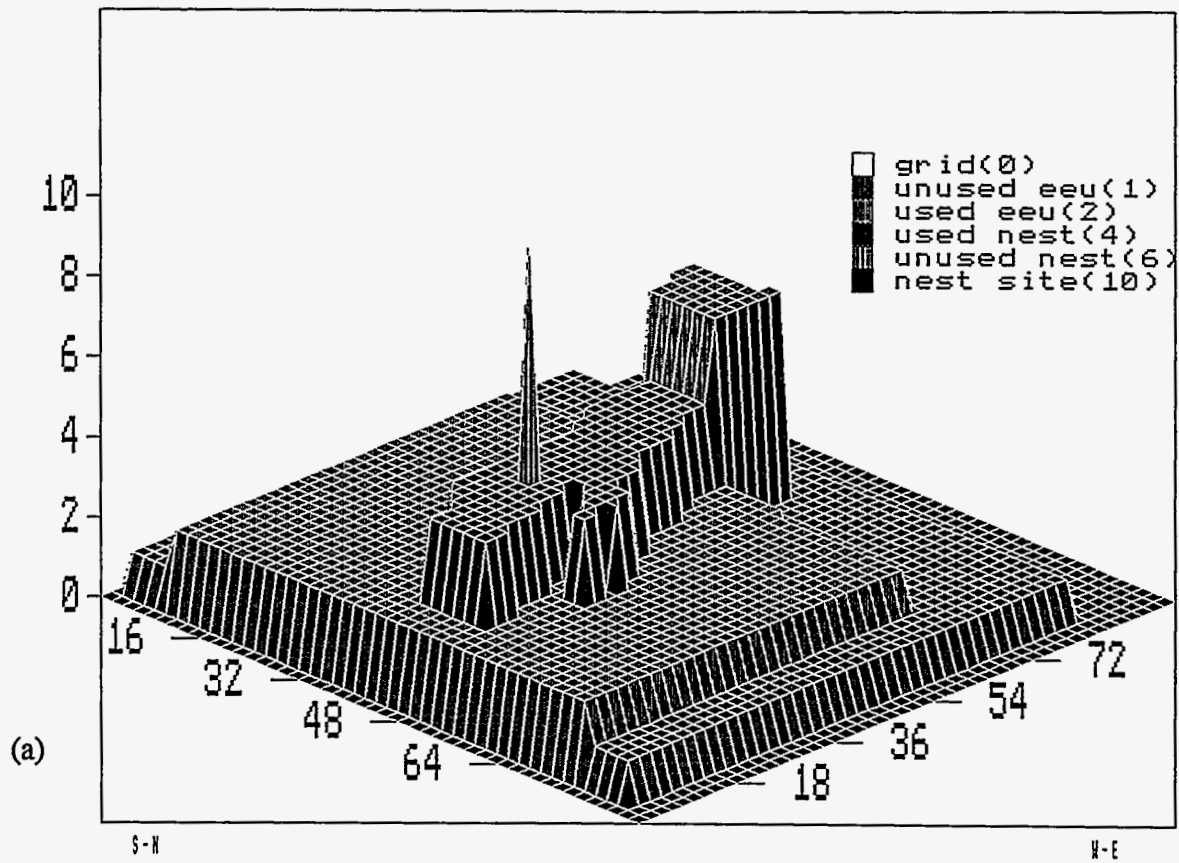

Figure 6. Demonstrated computer-simulated plots showing (a) potential nest site 53-46 of Ecological Exposure Unit 21 and (b) potential nest site 105-79 of Ecological Exposure Unit 40.

purpose. Satisfactory transport and use of these codes has been demonstrated at LANL's Ecology Group (ESH-20).

2.9.1.1 Cumulative HQ Estimation Method using ECORSK4

COPEC ingestion must be integrated from HR and potential nest site considerations. The method of cumulative HQ quantification is presented again in this section to illustrate how ECORSK4 develops the basic building blocks of the risk estimate. The model ECORSK4 integrates GIS information with basic toxicological information on a number of COPECs with basic physiological data to estimate Hazard Indices (cumulative HQs) from more than one COPEC in the EEU of a specific animal such as the Mexican spotted owl:

for nonradionuclides

$$HI = \text{Food} \times \text{Soilf} / \text{Bodwt} \times \sum_{j=1}^{ncs} \text{Occup}_j \times \sum_{l=1}^{ncoc} \text{SC}_{j,l} / (\text{Dr}_1 \times \text{Dar}_1), \quad (5a)$$

or,

for radionuclides

$$HI = \sum_{j=1}^{ncs} \text{Occup}_j \times \sum_{l=1}^{ncoc} \text{SC}_{j,l} / (\text{SAL}_1 \times \text{SALa}_1), \quad (5b)$$

where

- HI = cumulative HQ for all COPECs,
- Food = amount of food consumed by a given animal, kg/day,
- Soilf = fraction of food ingestion consumed as soil,
- Occup_j = occupancy factor on the jth contamination site,
- Dc_{j,l} = chronically consumed dose, mg-COPEC/kg-body weight-day for the jth contamination site (exposure dose) of the lth COPEC
- Dr₁ = consumed dose above which observable adverse effects may occur, mg-COPEC/kg-body weight-day of the lth COPEC,
- Dar₁ = adjustment factor for Dr₁ above for the lth COPEC,
- SC_{j,l} = soil concentration of COPEC, pCi-COPEC/kg-soil for the jth

- contamination site of the lth COPEC,
- SAL₁ = screening action level, pCi-COPEC/kg-soil of the lth COPEC,
- SALa₁ = adjustment factor for SAL₁ above for the lth COPEC,
- ncs = number of contamination sites,
- and
- ncoc = number of contaminants in the jth contamination site.

This approach assumes that sublethal doses of various contaminants are additive in their effect, rather than synergistic, antagonistic, or independent.

The following subsections will present a discussion of those elements in the above relationships which have not received adequate attention to clarify the model's use of the equations.

2.9.1.2 Daily Food Consumption (Food)

Daily food consumption of a given animal is estimated in ECORSK4 using the following relationships (EPA 1993a):

$$\text{Food} = 0.0687 \times \text{BODWT}^{0.886} \text{ mammals}, \quad (6a)$$

$$\text{Food} = 0.0582 \times \text{BODWT}^{0.651} \text{ birds}, \quad (6b)$$

$$\text{Food} = 0.0135 \times (\text{BODWT} \times 1000)^{0.773} \text{ reptiles and amphibians}, \quad (6c)$$

where;

Food = food consumption rate, kg/day, of dry matter and

BODWT = body weight of animal, kgfw.

It should be noted that these equations represent relationships that can be applied to the general types of animals specified above, however, more specific relationships for special subtypes are also available if more precision is required.

2.9.1.3 Soil Intake Fraction (Soilf) and Body Weight (BODWT)

A detailed discussion on the selection of Soilf (or F_s) was presented in Section 2.7.3 of this report. A body weight of 0.55 kgfw was assumed for both male and female Mexican spotted owl, although some variation occurs between and within sexes.

2.9.1.4 Occupancy Factor (Occup)

Occupancy factors are defined in this study as the fraction of the time in a given day that an animal spends feeding in a given area. Occupancy is assumed to be time averaged over a long period to obtain a probabilistic relationship. This factor can be determined on an areal basis if it is assumed that any given area within an animal's habitat is equally likely to serve as a feeding location for a given animal over the long term. However, many factors could restrict or enhance a given area to support feeding activities depending on the distribution of food in the EEU, the relative accessibility of feeding areas, and feeding patterns/habits of the predator. Two different cases were considered regarding the occupancy factor used for this study involving the Mexican spotted owl:

(I) all grid areas are equally accessible if they are within the HR of the animal:

$$Occup_i = A_i \sqrt{\sum_{j=1}^{ng} A_j E_{f_j}} \quad (7)$$

where;

- Occup_i = occupancy factor of the *i*th grid,
- A_i = area, km², of the *i*th grid within the HR of a given animal,
- A_j = area, km², of the *j*th grid within the HR of a given animal,
- E_{f_j} = enhancement factor of the *j*th grid within the HR of a given animal, and
- ng = number of grid cell sites within the HR of a given animal.

(II) occupancy is weighted based on the distance from a potential nest site following the form

$$e^{-r/400} \text{ (Johnson 1990),} \quad (8)$$

where *r* is the distance of a grid cell from the potential nest. This results in 60% of the foraging within about 188 ha and 95% within 821 ha (Johnson 1990).

Since the enhancement factor is part of the ECORSK4 input, the user is able to modify this relationship to reflect increased or decreased feeding in a specific grid area. It was noted earlier in this section that the mean contamination of a given COPEC is assumed to apply to the entire grid cell as defined in the model. Hence, the enhancement factor can be used to modify this assumption if desired. The location of the potential nesting site within an EEU determines which contaminated and noncontaminated grid cells are going to be included in the summation portion of Eq. 7. The selection process is discussed in the following subsection.

2.9.2 ECORSK4 Model Operation Strategies

Model operation follows an ordered procedure that can be summarized as follows:

- Create output files and enter input parameters;
- From input parameters
 - create grid system,
 - define EEU on grid system,
 - define potential nesting area on grid system,
 - locate COPECs on EEU,
 - define the HR from animal allometric data, and
 - define food intake rate from animal allometric data.
- Establish potential nesting sites in nesting area on
 - contaminated grids within the nesting area,
 - random nest sites within the nesting area, or
 - selected or known nesting sites within the nesting area.

- Establish grid cells to be included within the HR from a given potential nest site.
- Determine contaminated grid cells within the HR from a given nest site.
- Estimate HI from all contaminated grid cells in HR from a given nest site for a given COPEC.
- Repeat for each COPEC.
- Repeat for another potential nest site.
- Output partial and total HQ estimates.
- Plot 3-d graphics of partial and total HQ estimates.

2.9.2.1 Nest Site Establishment

ECORSK4 has the option of selecting potential nest sites on the basis of:

- randomness,
- automated placement on "contaminated" grid cells that are within the nesting habitat,
- user-specific locations, or
- any combination of the above three.

Figures 7A and 7b are computer simulated 3-d plots of the second option for the Mexican spotted owl on EEU-21 and EEU-40 sites, respectively.

2.9.2.2 Model Selection of Foraging Area (Home Range)

In this study it was assumed that the Mexican spotted owl would not have nesting sites outside of the nesting areas, but could forage in both the nesting and adjoining EEU-designated areas. After establishment of a given nest site to be used in the HQ determination, the model uses the HR estimate to determine specific grid cells within the EEU that are included around the specific nest site.

This is accomplished by systematically increasing the coordinates around a potential nest site in inscribed squares within increasing concentric circles formed around the nest site that results in a "square doughnut" appearance, and increasing square

doughnut holes in the middle. This iterative process is repeated until the sum of the enclosed grid cells equals the HR of the animal in question. The selected grid cells must be within the EEU of the animal in question, or they are ejected. Consequently, the final pattern of the selected grid cells may deviate from a perfect square around the potential nest site. Finally, this routine is repeated for each potential nest site selected in the model.

2.9.2.3 Identification of Contaminated Grid Cells in the HR for a Given Nest Site

The model searches each grid cell within a HR around a nest site for COPECs to be included in HQ calculations. In addition, it searches the perimeter of the HR and includes contaminated grid cells within one grid cell length in the HQ calculations for a given nest site. This strategy is followed because all contaminated grid cells are assigned the next highest cell numbers on both grid axes. For example, if the grid coordinates of a given contaminated grid are estimated as 15.5 and 120.2, for X- and Y-axes, respectively, they are coded as 16 and 121 for use in the model. The model also addresses contamination areas which may exceed the area of a grid cell. If the latter is made to occupy more than one grid area, then the overlap from the perimeter of the HR can exceed the length of a grid cell.

2.9.2.4 HQ Estimation Procedure

The model tests each contaminated grid cell within the HR of an animal at a given potential nest site for completeness of information required for executing Eqs. 5a and 5b. This is necessary because the database obtained through FIMAD may not have information for all COPECs it identifies within the EEU of a given animal such as the Mexican spotted owl. Hence, all concentration values that are reported as being less than zero are set to zero. Furthermore, if the reported contaminant concentration is below mean background (organic contaminants excluded), then the sample concentrations are made equal to the reported background levels. Similarly, if the toxicological reference dose (D_r) described in

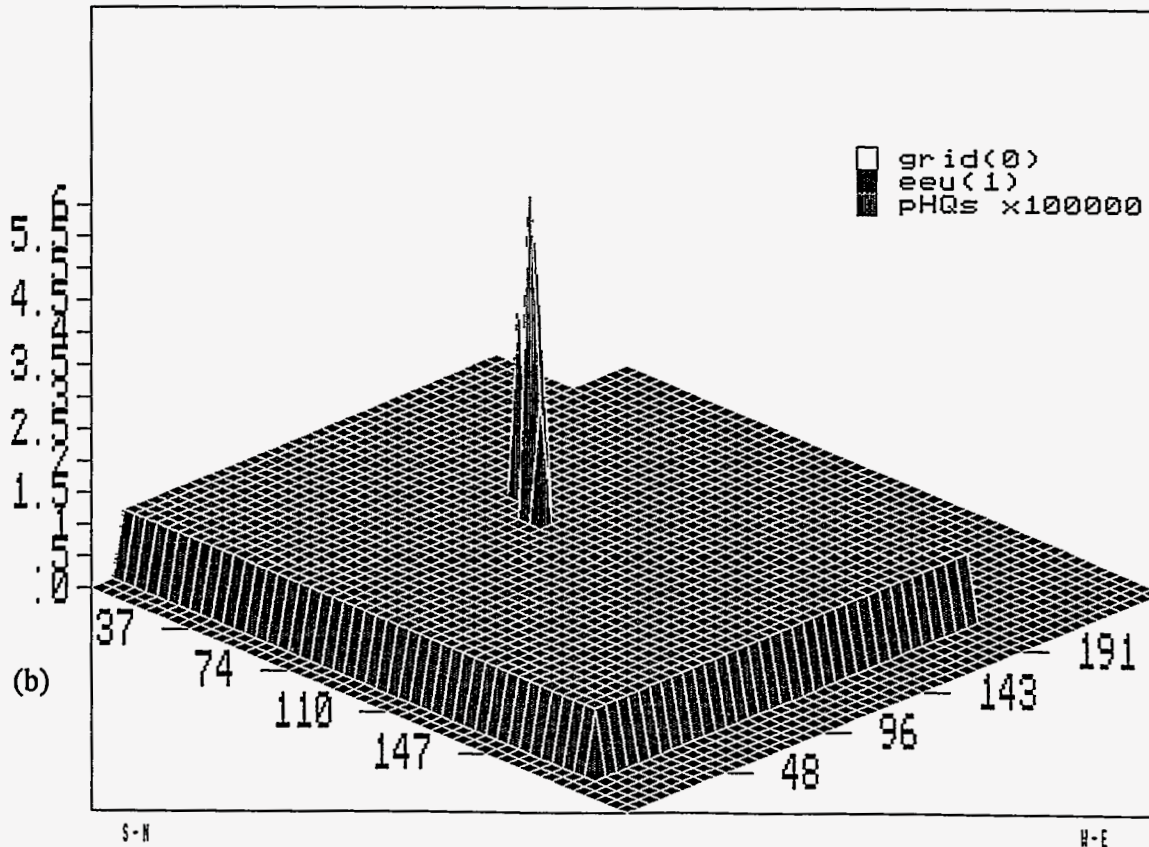
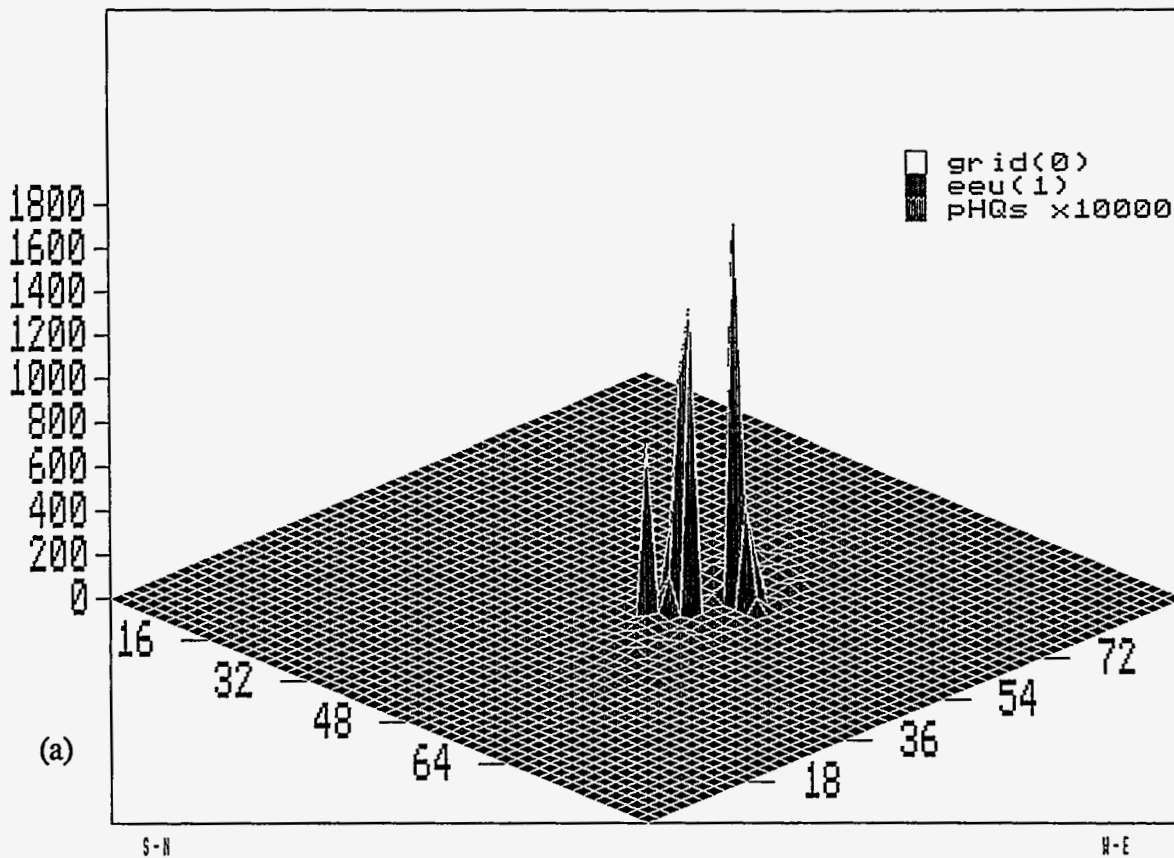

Figure 7. Demonstration of computer simulated plots of hazard index values for (a) EEU-21 and (b) of EEU-40, respectively when the nest location option selected is automated placement on "contaminated" nesting area grid cells.

Eq. 5a was not included or reported as zero, then the corresponding COPEC is excluded from the HQ calculations. The same criteria applies to SAL data reporting (Eq. 5b). Hence, the number of COPECs for which an HQ is estimated may vary from one grid cell to another. The database containing this information (eeuinp.dat) should be updated, and HQ estimates should be recalculated periodically.

2.9.3 Model Output

The reporting of results in this section from the output of ECORSK4 will be limited to examples of 3-d graphical output. A more complete set of results from other analytical output is discussed in the results and discussion sections of this report. The presentation given here is only a small portion of the potential output for this model, but should suffice in illustrating 3-d output capabilities. Three 3-d plots have already been presented, one of which required overlaying of HI data output (hq.dat) for a given random nest site on the EEU grid file (gridxy.dat). Other plotting options are described below.

2.9.3.1 Demonstrated 3-d Graphics of HIs by Nest Site

The ECORSK4 model outputs (hqp.dat) partial HQs contributed by all contaminated grid cells within the HR surrounding each potential nest site. Using the SELECT code (hqpo.dat, see Figure 4), the user can select a specific nest site and view the partial HQs by COPEC from each contaminated grid within the HR of a given animal's nest. ECORSK4 sums HQs for all COPECs to generate HIs by nest site and places this summary data in hq.dat. The plots shown in Figures 8a and 8b show the HIs by nest site (hq.dat) for EEU-21 and EEU-40, respectively. There is a significant difference in size between the sites, and it is reflected in the observed variance of the HIs. On the EEU-21 site, practically all of the EEU is included in most HR determinations, and one can see less variation (see Figure 8a) than where the EEU is significantly larger than the HR. The latter results in greater variation in HIs such as is shown in Figure 8b. All 3-d plots are generated from the code PLTRSK as illustrated in Figure 4.

2.9.3.2 Demonstrated 3-d Graphics of Total HQs by COPEC

The model also outputs total HQs by COPEC for 3-d graphics presentation (hqpc.dat) which can then be used as input to SELECT to produce an output (hqpc.dat) which is then used as input to PLTRSK to create the desired plots. The plots shown in Figures 9a and 9b for EEU-21, and Figures 10a and 10b for EEU-40 show the HQ contribution from several COPECs. The specific COPECs selected for plotting contributed substantially to the HI in each case. Note the unequal contribution of HQ from these COPECs from different nest sites.

2.10 Statistical Analyses

2.10.1 Simple Distribution

Model output data were imported to spreadsheet format and COPECs and contaminated grid cell locations were sorted by HQ in descending order. This enabled the identification of the most problematic COPECs and locations on a relative basis. Hazard Index distributions were listed in table format and arithmetic means were computed by Risk Source and Hazard Value Type as defined in Section 2.8.

2.10.2 Hypothesis Testing

In comparison to issues regarding the parameters used to quantify risk and the values derived or chosen to represent those parameters, statistical analyses of differences in Risk Source means is relatively unimportant.

It is important not to use "natural" background levels of COPECs to screen contaminants from further consideration. Because COPECs can exert their effect on a threshold basis even in small amounts, statistics are not presented in this report for testing hypotheses of Risk Source parameter or distribution differences.

For those interested in separating risk associated with different sources, statistical analyses should be performed. The key question likely to confront those who perform this type of analysis would be whether to apply *parametric* or *nonparametric* statistics. For example, if one considers the

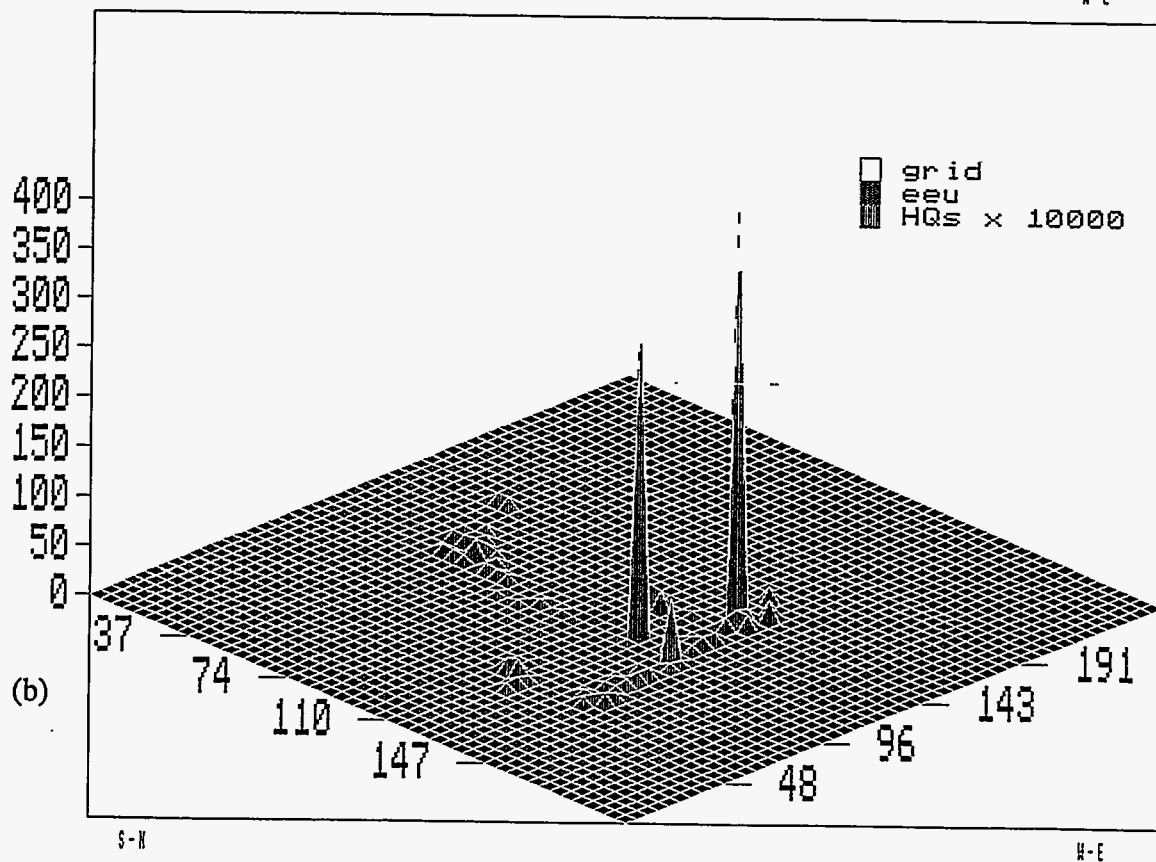
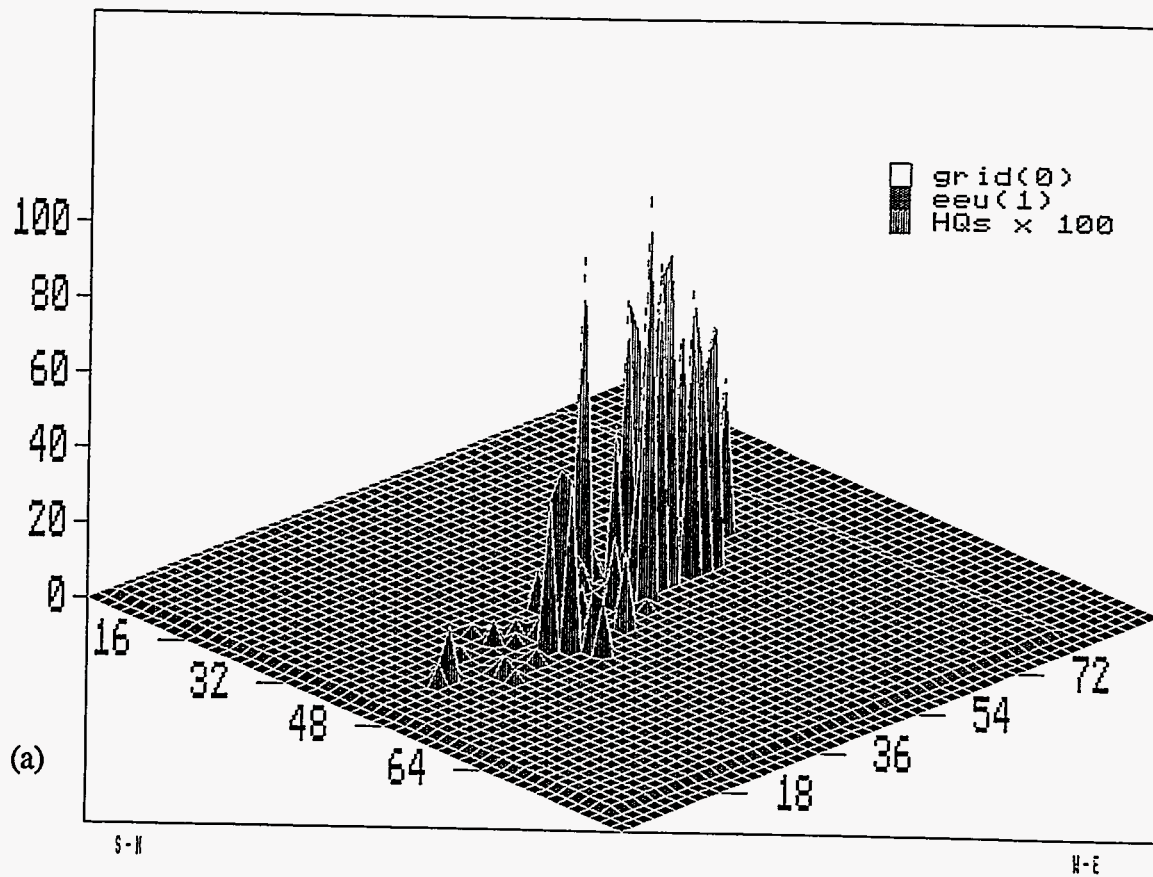

Figure 8. Unadjusted hazard index (cumulative hazard quotient) for each of 100 randomly selected potential nest sites of the Mexican spotted owl in (a) Ecological Exposure Unit 21 and (b) Ecological Exposure Unit 40.

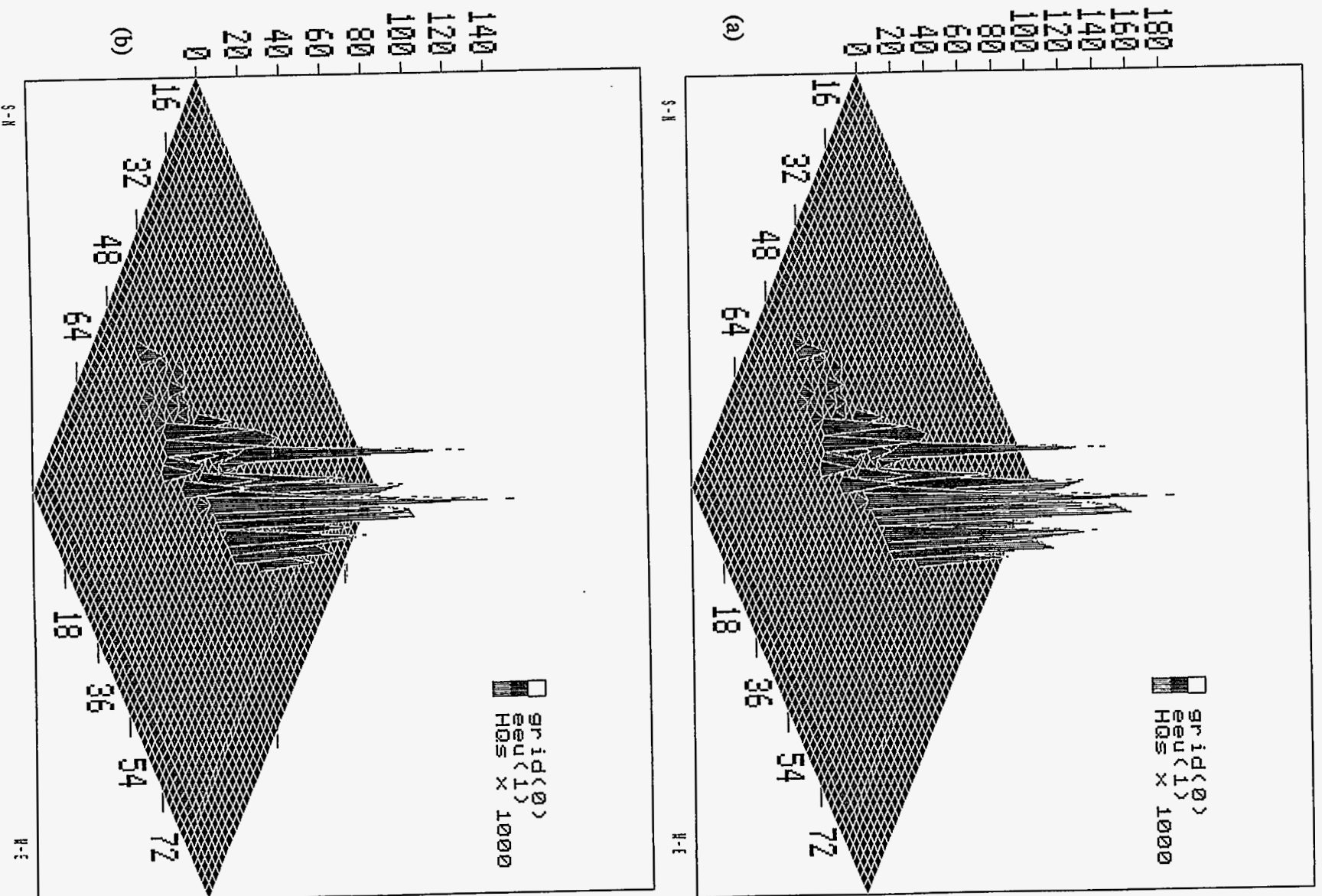

Figure 9. Hazard quotient from (a) nickel and (b) Cs-137 at random nest sites of Ecological Exposure Unit 21.

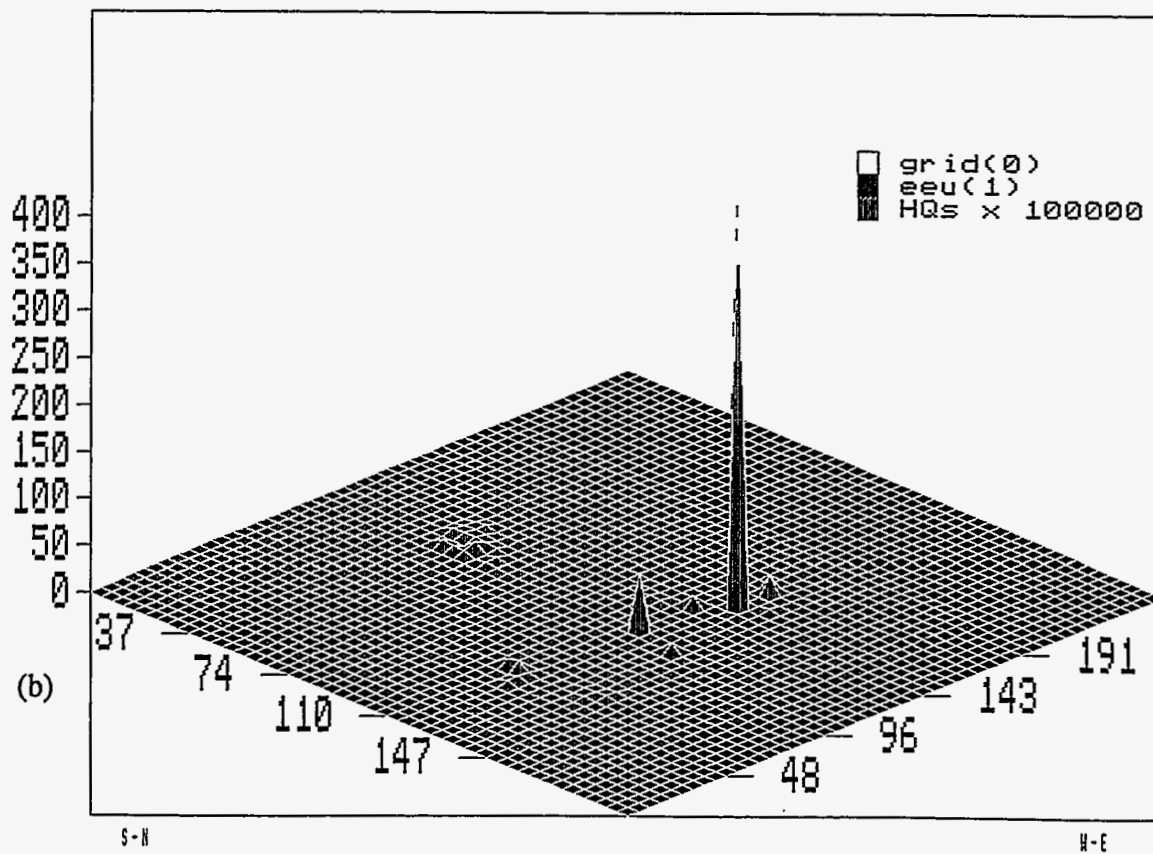
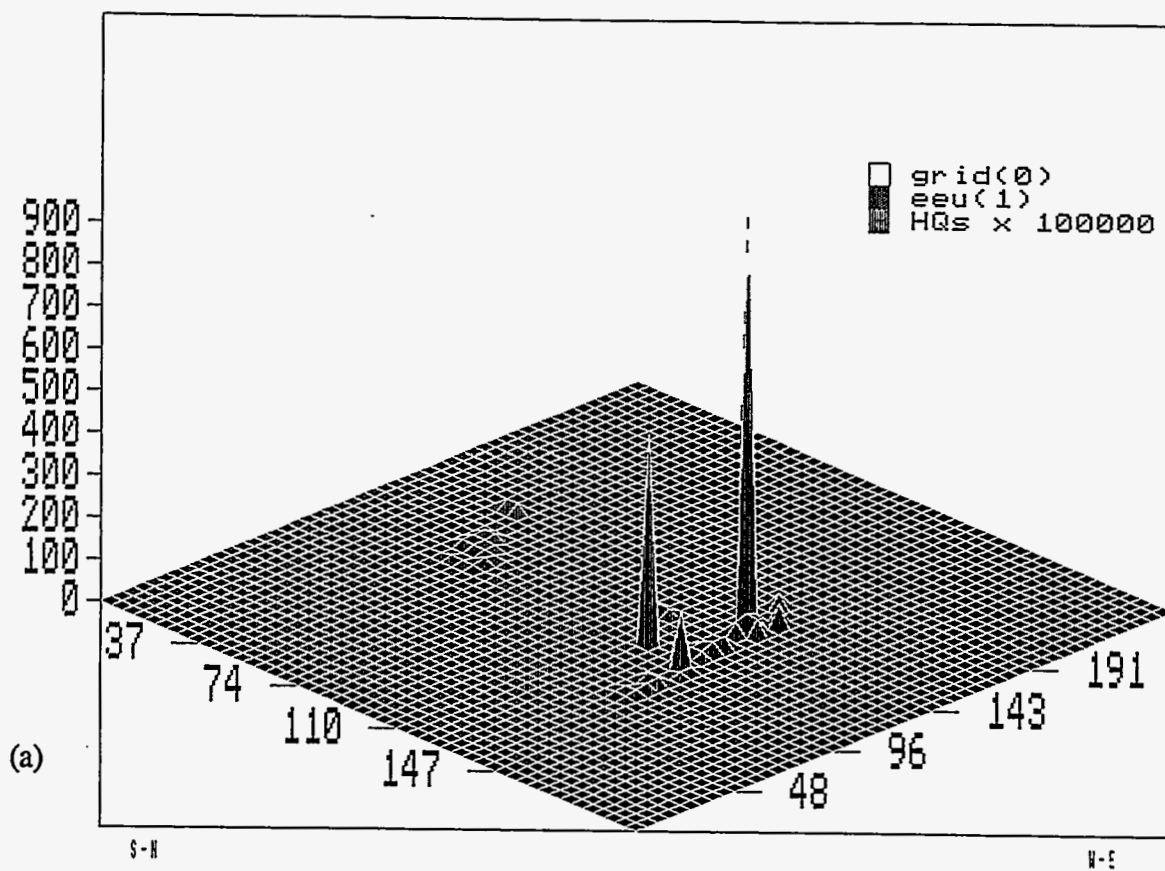

Figure 10. Total hazard quotient from (a) antimony and (b) Th-232 at random nest sites of Ecological Exposure Unit 40.

data on concentration of COPECs in soil, the collection of sampling data is not a complete population in the truest sense because it does not consist of this type of information for each and every grid cell in the EEU's. The data, however, represent the complete population of "known" values sampled for each EEU and entered into FIMAD at some point in time. Finally, the assumption that the distributions of data underlying the risk source estimates made in this study are normal would not be unlike assumptions of independence and randomness made in similar studies accepted by refereed peer review (Clifford et al. 1995).

3.0 Results

3.1 Unadjusted Mean Hazard Index

Table 1 reports the HI averaged for 100 potential nest sites for (a) "weighted" and (b) "unweighted" foraging cases. As stated previously, the weighted occupancy case is more realistic. The unweighted occupancy case is presented for comparison purposes in order to gain an understanding of how risk distributions and their variance are affected by improvements in model realism, but only the weighted case (Table 1B) is discussed with regard to risk.

The Unadjusted HI, calculated as the mean total HQ, is 0.20 and 0.0015 for EEU-21 and EEU-40, respectively. The HI is a sum of the HQs for all COPECs, thus serving as an index of cumulative effects from multiple contaminants and multiple sites. Hazard indices less than 1.0 indicate that, under the assumptions and conditions applied, the sites pose no unacceptable risk to the Mexican spotted owl. The HI measures additive or linear effects, making no measure of synergistic effects, amelioristic effects, bioaccumulation, bioconcentration, nor biomagnification.

3.2 Hazard Index Distribution

Figure 11 shows plots of the frequency distribution of cumulative HQs for the 100 repetitions of model nest location for EEU-21 and -40. The actual values are listed in Tables A-3 and A-4 in the appendix. When each set of 100 values is averaged, the result is the Unadjusted mean HIs of Table 1B. Table A-3 and A-4 values are also plotted in

3-d view in Figure 8. In the weighted case, occupancy is positively related to distance from potential nest sites such that an owl spends more time foraging close to the theoretical nest. Since the contaminated grid cells occur in a cluster close to the nesting habitat compared to the rest of the foraging area in EEU-21, the weighted case generated several HIs in the distribution of 100 that were substantially higher than the maximum HI in the unweighted case. One of 100 HI values were greater than 1.0 (Table A-3). Despite this, the mean HI for all 100 repetitions was much lower for the weighted case (0.20, Table 1B) compared to the unweighted case (0.69, Table 1A). This was true for both EEU's. Thus, improving model/foraging realism, in this case, decreased the risk estimate by 0.5 HI units on average.

The standard error of the mean around HIs represents the variability associated with spatial changes in sampling results within and between repetitions. This variation was substantially greater (precision lower) when occupancy was weighted for both EEU's. In the unweighted cases, in effect there is more "foraging" on the same grid cells from one repetition to another. In the weighted case, there is greater distinction between groups of grid cells that most impact HIs from one nest location to another.

Tables A-5 and A-6 in the appendix present HQs by COPEC totaled across contaminated sites (grid cells). These results also indicate that the sites pose no unacceptable risk to the Mexican spotted owl. Cesium-137, K-40, Al, V, Ra-226, and Sr-90 are among the highest ranked COPECs common to the two EEU's. The COPEC with the highest HQ for either EEU, Cs-137 (Table A-6), is about an order of magnitude below the value necessary to present an unacceptable potential risk to the owl. However, since radionuclides accounted for a substantial portion of the relative risk (Tables A-5 and A-6), it is important to recall from the discussion in Section 2.7.4.2 that risk from radionuclides has likely been overestimated because the radionuclide RfDs (SALs) used are more protective than that suggested by the IAEA.

Table 1. Mean hazard index (HI) and mean partial hazard quotients (HQs) by Hazard Value Type and Risk Sources for (A) distance-unweighted and (B) distance-weighted foraging for the preliminary risk assessment of the Mexican spotted owl at the Los Alamos National Laboratory. HI and HQ values are followed by the mean standard error and number of observations in parenthesis. (See Section 2.8 for definitions of Hazard Value Types and Risk Sources.)

A. UNWEIGHTED FORAGING Ecological Exposure Unit - 21			
Risk Source	Hazard Index (Cumulative COPEC)	Mean Partial HQ × Grid Cell	Mean Partial HQ × Grid Cell × COPEC
Unadjusted × Random Nest	0.69 (±6.16E-02) (100)	1.82E-03 (±7.50E-03) (37749)	8.66E-05 (±1.04E-03) (790866)
Background × Random Nest	0.19 (±2.14E-02) (100)	5.11E-04 (±2.87E-04) (37749)	2.66E-05 (±6.21E-05) (724629)
Nest on Contaminated Grid Cell Within Nesting Zone	0.70 (±4.96E-02) (86)	1.81E-03 (±7.43E-03) (33429)	8.60E-05 (±1.03E-03) (701425)
Ecological Exposure Unit - 40			
Unadjusted × Random Nest	6.43E-02 (±3.73E-02) (100)	9.07E-04 (±1.18E-03) (7095)	4.44E-05 (±2.22E-04) (144734)
Background × Random Nest	4.41E-02 (±3.20E-02) (100)	6.26E-04 (±4.46E-04) (7051)	3.29E-05 (±9.46E-05) (133947)
Nest on Contaminated Grid Cell Within Nesting Zone	3.17E-02 (±1.56E-02) (16)	8.84E-04 (2.59E-03) (574)	4.32E-05 (±5.65E-04) (11745)
B. WEIGHTED FORAGING Ecological Exposure Unit - 21			
Risk Source	Hazard Index (Cumulative COPEC)	Mean Partial HQ × Grid Cell	Mean Partial HQ × Grid Cell × COPEC
Unadjusted × Random Nest	0.20 (±0.26) (100)	5.25E-04 (±3.92E-03) (37749)	2.50E-05 (±5.40E-04) (790866)
Background × Random Nest	5.22E-02 (±6.62E-02) (100)	1.38E-04 (±2.68E-04) (37749)	7.20E-06 (±3.24E-05) (724629)
Nest on Contaminated Grid Cell Within Nesting Zone	0.15 (±0.28E-02) (86)	3.85E-04 (±3.77E-03) (33429)	1.83E-05 (± 5.21E-04) (701425)
Ecological Exposure Unit - 40			
Unadjusted × Random Nest	1.53E-03 (±5.06E-03) (100)	2.16E-05 (±1.09E-04) (7095)	1.06E-06 (±1.56E-05) (144734)
Background × Random Nest	1.12E-03 (±3.96E-03) (100)	1.59E-05 (±8.27E-05) (7051)	8.37E-07 (±1.03E-05) (133947)
Nest on Contaminated Grid Cell Within Nesting Zone	2.44-02 (±6.53E-03) (16)	6.80E-04 (8.63E-04) (574)	3.32E-05 (±1.21E-04) (11745)

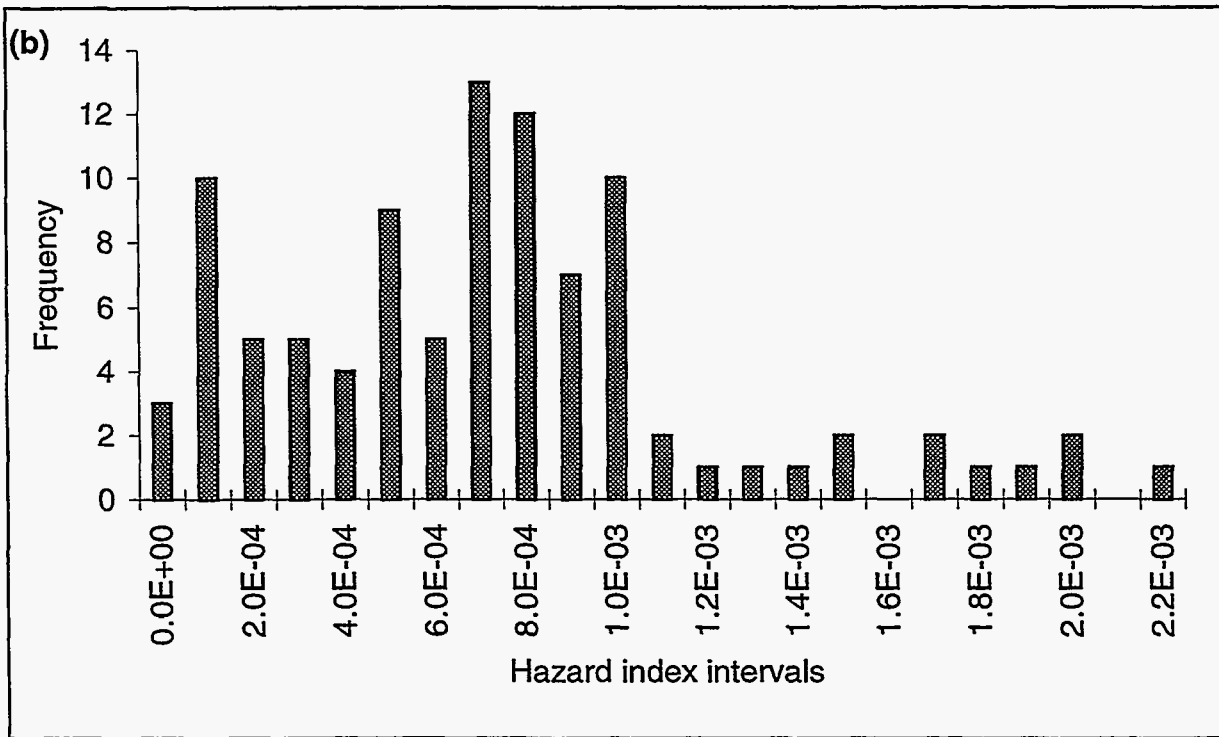
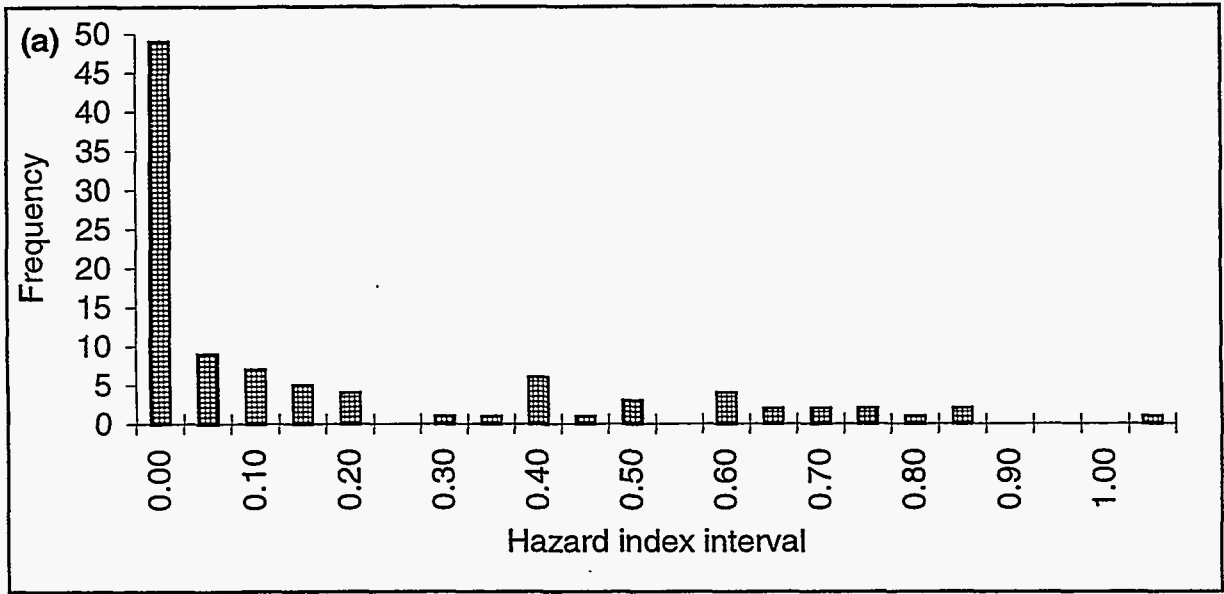

Figure 11. Distribution of hazard index values (cumulative hazard quotient) across range of 100 randomly selected potential nest sites of the Mexican spotted owl in (a) Ecological Exposure Unit 21 and (b) Ecological Exposure Unit 40.

Figure 12 is a map of the spatial distribution of Unadjusted HIs (cumulative HQs) for each of 100 random potential nest sites of EEU-21. The potential nest sites with the highest relative risk are clustered generally in the third quarter of the nesting zone going from west to east. The spatial distribution of HIs for EEU-40 was not mapped because the estimated risk for this area was low (\bar{x} , Unadjusted = 0.00153; \bar{x} , NOC = 0.0244), and of no consequence.

Figure 13 shows the spatial distribution of HQ ranges for contaminated grid cells in EEU-21. The plotted HQs in Figure 13 represent the risk contributed by each contaminated grid cell to the total risk (HI) for potential nest #1 of EEU-21 (nest site #1 shown in both Figs. 12 and 13). The highest contribution to risk in EEU-21 is from a small cluster of partial HQs located centrally (east to west) along the northern edge of the nesting/roosting zone, and extending north-easterly across TA-21 and into DP Canyon (Fig. 13).

4.0 Discussion

4.1 Management Use of Results

Data such as that in Figure 13 can be used to identify the particular source locations of contamination, which if managed, would most effectively maintain the risk to the owl from contamination at acceptably low levels. Data such as that in Figure 12 on the geographical distribution of risk by nest location can be used to identify how to manage the spatial aspects of owl habitat so that risk to the owl is maintained at acceptably low levels; this could include the management of owl habitat, facility operations, and/or siting of new facilities.

4.2 Limitations and Uncertainty

The potential for COPECs to bioaccumulate, bioconcentrate, or biomagnify in the Mexican spotted owl was not assessed in this study. A few cases in history have implied that the higher the trophic level of an organism on a food chain, the greater is its susceptibility for biomagnification (Leidy 1980). In this scenario, carnivores such as the Mexican spotted owl could be more subject to biomagnification than herbivores.

However biomagnification is more apparent in aquatic systems than terrestrial and recent studies question the validity of biomagnification in terrestrial systems (Laskowski 1991). While biomagnification of the chlorinated hydrocarbons (organochlorines) is fairly well proven (Walker 1990), the concentration of heavy metals in animals is not necessarily a property of food chains (Laskowski 1991). Heavy metal biomagnification has been implicated mostly in mammals (Shore and Douben 1994, Hegstrom and West 1989, Ma 1987). Conclusions to the contrary are that

- heavy metal biomagnification is not a rule in terrestrial food chains (Laskowski 1991, Beyer et al. 1985, Grodzinska et al. 1987, Willamo and Nuorteva 1987, Nuorteva 1988),
- "biomagnification alone cannot lead to very high concentrations of most heavy metals in top carnivores" (Laskowski 1991), and
- "biomagnification cannot be responsible for toxic effects of heavy metals in terrestrial carnivores" (Laskowski 1991).

Of the top 10 COPECs in EEU-21 and EEU-40, nickel, aluminum, antimony, lead, vanadium, and manganese are metals.

Organic forms of mercury (Hg) are documented as being especially prone to biomagnification. Only inorganic Hg was considered in this study. Although canyon bottoms are likely to contain anaerobes that are capable of methylating Hg, its relative rank in cumulative HQ for EEU-21 was thirty-third with an HQ of 1.56E-04 and for EEU-40 it was twenty-first with an HQ of 1.02E-05. The highest ranked organics for EEU-21 were aroclor-1260 and -1254 with HQs of 4.45E-04 and 6.15E-05, respectively (Table A-5). For EEU-40 the highest ranked organics were also aroclor-1260 and -1254 with HQs of 3.68E-06 and 3.17E-06, respectively (Table A-6).

If a worst case UF of 1000 (Calabrese and Baldwin 1993) for extrapolating RfDs across phylogenetic lines in aquatic systems were applied in this terrestrial system to the chlorinated hydrocarbon COPECs, the

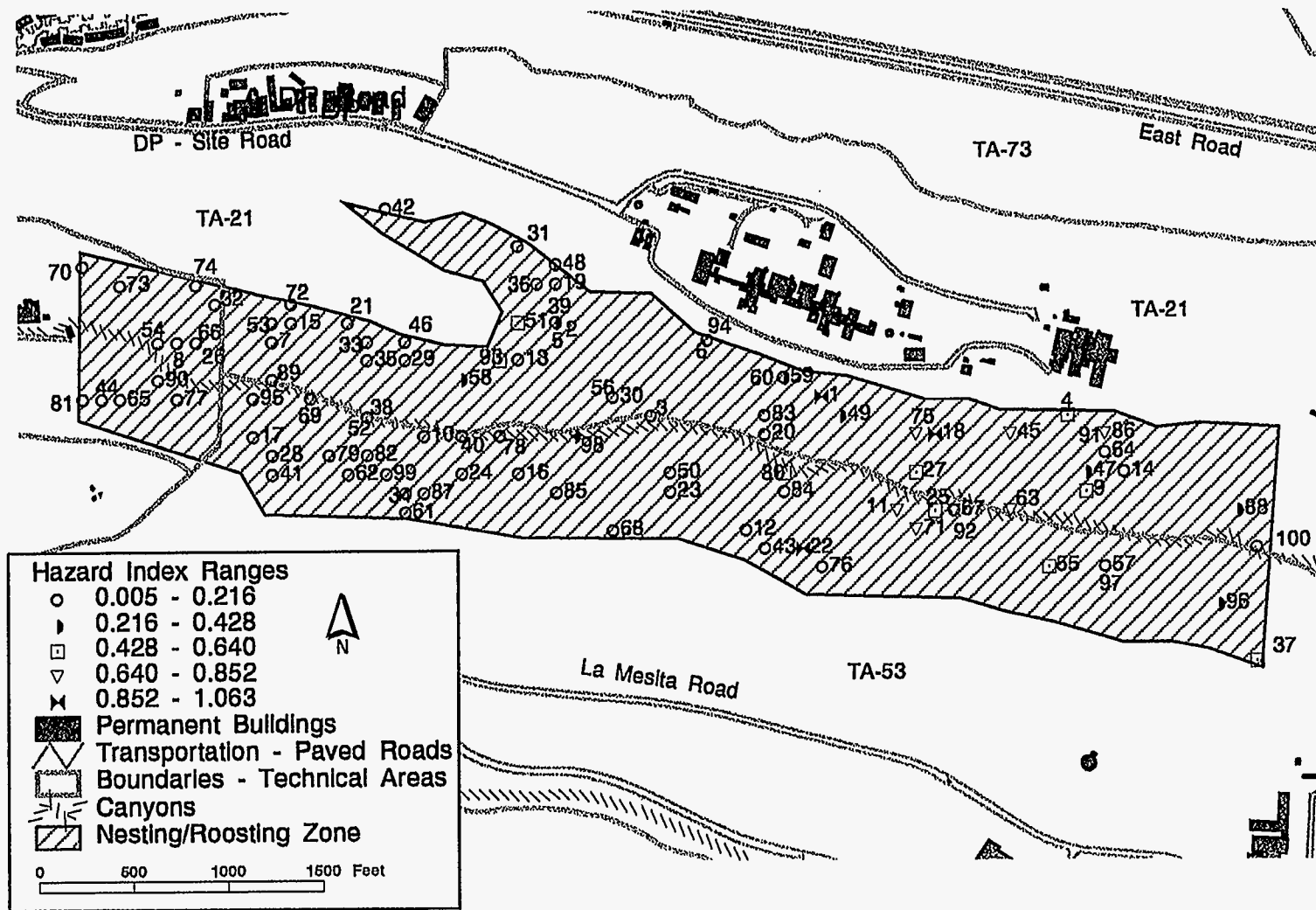

Figure 12. Spatial distribution of Unadjusted HIs (cumulative HQs) for each of 100 random potential nest sites of the Mexican spotted owl in EEU-21 in the spatially-weighted foraging case.

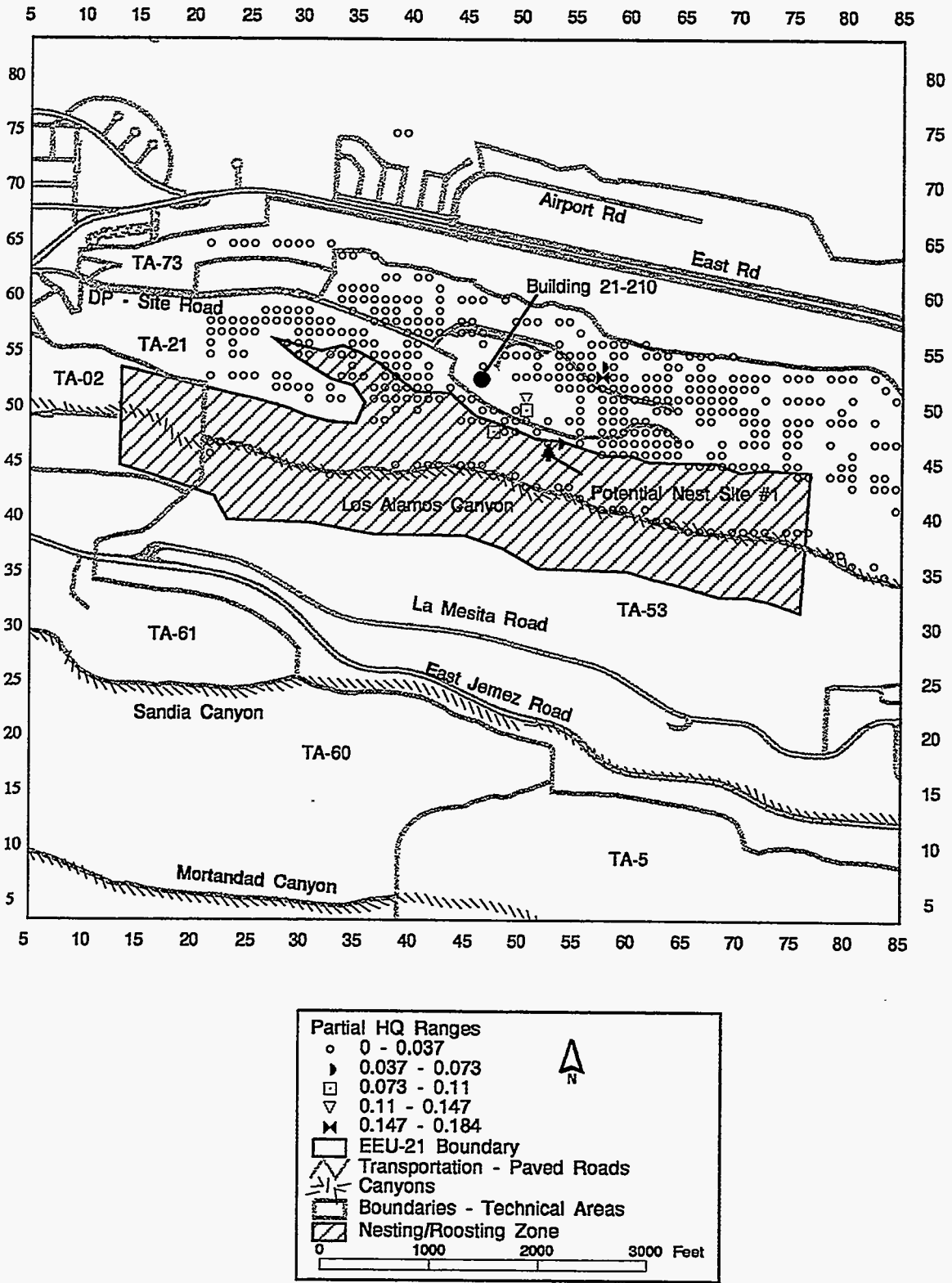

Figure 13. Spatial distribution of Unadjusted HQs by grid cell for the first of 100 random potential nest sites of the Mexican spotted owl in EEU-21 in the spatially-weighted foraging case. Identifies the sources of partial risk contributing to the total risk at potential nest site No. 1.

highest ranked HQ would be about 4.5E-01. Nevertheless, the issue of contaminant potential biomagnification in the Mexican spotted owl cannot yet be completely dispelled because

- biomagnification of heavy metals to toxic levels can occur from relatively low concentrations in soil (Ma 1987),
- even if a chemical or its metabolites have high NOAELs in long-term ecotoxicity or toxicity tests, incomplete metabolic elimination of contaminants, also known as bound residues, can result in unacceptable risk from bioaccumulation or biomagnification (Franke et al. 1994),
- bioaccumulation factors (BAFs) have not yet been specifically established for the particular site conditions and receptor of this study.

The Quotient Method does not assess the likelihood of the effect(s) under consideration. Using a more sophisticated ecological transport model such as BIOTRAN.2 (Gallegos 1996), greater insight into the magnitude of the effects expected at various levels of exposure can be obtained by evaluating the full stressor-response curve instead of a single point and by considering the frequency, timing, and duration of the exposure (EPA 1996, EPA 1992a).

Some of the uncertainties associated with the use of reference doses have been discussed or listed in Section 2.7.4. Limitations of this study with regard to the potential for contaminant bioaccumulation or biomagnification have been discussed in this section. Other sources of uncertainty have been discussed throughout the report and additional discussion is provided by Calabrese and Baldwin (1993) and Clifford et al. (1995). Table 2 summarizes the assumptions made in this study, categorized according to whether we consider them "conservative", "realistic", or "nonconservative". As previously stated, an adjustment of values that serve as input to the risk determinations was not applied because the collective amount of uncertainty originating from different sources is great enough and/or variable enough such that adjustment for such

uncertainty would make the results unusable because of large total margins of introduced error.

Finally, this study assessed the potential risk to the Mexican spotted owl from existing soil contaminants at LANL. The existing contamination studied has no particular relevance to the DARHT except for any, if any, additional contribution that the DARHT may make to the existing contaminant load. Potential effects to the Mexican spotted owl from activities related specifically to the DARHT have only been qualitatively postulated (DOE 1996; Keller and Risberg 1995). Potential contaminant releases from normal and off-normal operations and from postulated accidents involving the DARHT as identified in the DARHT EIS (DOE 1996) and in the DARHT Biological Assessment (Keller and Risberg 1995) must be quantitatively assessed for potential impact to the Mexican spotted owl in order to meet the DARHT-related commitments made by the DOE regarding protection of natural resources. In a pilot study at LANL (LANL 1995) a methodology was developed which can be modified for making this assessment.

Additional TES to be assessed in fiscal year 1997 include the peregrine falcon (*Falco peregrinus*), bald eagle (*Haliaeetus leucocephalus*), southwestern willow flycatcher (*Empidonax traillii extimus*), Jemez Mountain salamander, and New Mexico meadow jumping mouse. As with the owl, EEU's specific to each species will be developed and corresponding toxicological reference data that is closest to each species phylogenetically will be used so that particularly sensitive taxa are given full consideration.

5.0 Conclusions

The assumptions in Table 2 were made in calculating risk from contaminants to the Mexican spotted owl. The assumption perhaps of greatest importance is that the use of human-based RfDs for radionuclides most likely leads to an overestimate of risk to the owl. Under the stated assumptions, the sites pose no unacceptable risk to the Mexican spotted owl. Additional assessment is needed in the areas of

- potential biomagnification,

Table 2. The assumptions, conditions, and factors used in calculating risk from contaminants.

Conservative (overestimate risk)	Realistic	Nonconservative (underestimate risk)
all COPECs assumed to have same biological effect	FIMAD database is current and accurate	risk not estimated for contaminants for which RfDs not available
radioactive decay of radionuclides not calculated	RfDs/NOAELs for metals based on avian test species and are chronic	environmental restoration not factored
antagonism not assessed		quotient method not probabilistic
FIMAD database is current and accurate	mean natural background COPEC values, not UTLs, used for inorganics	FIMAD database is current and accurate
	average, not maximum, COPEC soil concentrations used	
RfDs (SALs) for radionuclides based on humans, which are between 185 and 3650 times more protective of animals than IAEA standard for protection of animals	uncertainty factor not applied to across-animal-class NOAELs for organic COPECs	
contamination level measured at sampling points assumed for 100 by 100 ft area		
assumed bioavailability of COPECs = 100%		
% of dietary food intake as soil = 5		

- the establishment of NOAELs for the organic and radionuclide COPECs that are more directly applicable to avian species,
- exposure pathway definition,
- toxicological information on the Mexican spotted owl, and
- grouping of COPECs by biological effect types, including the consideration of synergism and/or antagonism.

Impact to the Mexican spotted owl from potential contaminant releases identified in the DARHT EIS as related to normal, off-normal and accident conditions remain to be quantitatively assessed in order to meet commitments made by the Department of Energy.

Acknowledgments

We appreciate the value of ESH-20 management (Teralene Foxx, John Huchton,

and Diana Webb) providing us with the resources to complete this work and for creating the conditions necessary for us to be productive. Terrell Johnson provided information on owl nesting habitat and foraging patterns. Kim Nguyen and Hector Hinojosa edited this report. Belinda Gutierrez compiled the report. Reviewers included Joel Lusk of the US Fish and Wildlife Service, John Huchton, Roger Ferenbaugh, Randy Balice, and Leslie Hansen.

Literature Cited

Allen H, Brewer L (1986) Progress report no. 2 for the cooperative administrative study to monitor spotted owl management areas in national forests in Washington. USDA Forest Service, Pacific Northwest Region, Portland, OR.

Bailey, VB (1971) Mammals of the southwestern United States, with special

reference to New Mexico. Dover Publications, Inc., New York.

Bennett K, Biggs J, Fresquez P (1996) Radionuclide Contaminant Analysis of Small Mammals, Plants, and Sediments within Mortandad Canyon, 1994. Los Alamos National Laboratory report LA-13104-MS.

Beyer WN, Conner EE, Gerould S (1994) Estimates of Soil Ingestion by Wildlife. *J Wildlife Manage* 58(2):375-382.

Beyer WN, Pattee OH, Sileo L, Hoffman DJ, Mulherin BM (1985) Metal Contamination in Wildlife Living Near Smelters. *Environ. Pollut A* 38:63-86 In Laskowski R 1991 Are the Top Carnivores Endangered by Heavy Metal Biomagnification? *Oikos* 60:387-390.

Biggs JB (1995) Biological Information Document for the Radioactive Liquid Waste Treatment Facility. Los Alamos National Laboratory report LA-UR-95-2681.

Block WM, Clemente F, Cully JF, Dick JL, Franklin AB, Ganey JL, Howe FP, Moir WH, Spangle SL, Rinkevich SE, Urban DL, Vahle JP, White GC (1995) Recovery plan for the Mexican spotted owl (*Strix occidentalis lucida*). USDI Fish and Wildlife Service, Vol. I, Albuquerque, NM.

Calabrese EJ, Baldwin LA (1993) Performing Ecological Risk Assessments. Lewis Publishers, Chelsea, Michigan.

Carriere D, Fischer K, Peakall D, Angehrn P (1986) Effects of Dietary Aluminum in Combination with Reduced Calcium and Phosphorus on the Ring Dove (*Streptopelia risoria*). *Water, Air, and Soil Poll* 30:757-764.

Cecil HC, Bitman J, Lillie RJ, Fries GF, Verrett J (1974) Embryotoxic and teratogenic effects in unhatched fertile eggs for hens fed PCBs. *Bull Envir Cont and Toxicol* 11(6):489-495.

Clifford PA, Barchers DE, Ludwig DF, Sielken RL, Klingensmith JS, Grahm RV, Marcy IB (1995) An approach to

quantifying spatial components of exposure for ecological risk assessment. *Environ Toxicol Chem* 14(5):895-906.

Davison KL, Sell JL (1974) DDT thins shells of eggs from mallard ducks maintained on *ad libitum* or controlled-feeding regimens. *Arch Environ Contam Toxicol* 2(3):222-232.

DOE (U.S. Department of Energy) (1996) Dual Axis Radiographic Hydrodynamic Test Facility Final Environmental Impact Statement: Mitigation Action Plan. Department of Energy, Albuquerque Operations Office, Los Alamos Area Office, Albuquerque, New Mexico, DOE/EIS-0228.

DOE (U.S. Department of Energy) (1995) Dual Axis Radiographic Hydrodynamic Test Facility Final Environmental Impact Statement. U.S. DOE report DOE/EIS-0228.

Edens FW, Benton E, Bursian SJ, Morgan GW (1976) Effect of Dietary Lead on Reproductive Performance in Japanese Quail (*Coturnix coturnix japonica*). *Toxicol Appl Pharmacol* 38:307-314.

EPA (U.S. Environmental Protection Agency) (1989) Risk assessment guidance for Superfund, Vol. 2, Environmental evaluation manual. EPA/540/1-89/001, Office of Emergency and Remedial Response, Washington, DC.

EPA (U.S. Environmental Protection Agency) (1992a). Framework for Ecological Risk Assessment. EPA report EPA/630/R-92/001, Risk Assessment Forum, Washington, DC.

EPA (U.S. Environmental Protection Agency) (1992b) IRIS2 (Integrated Risk Information System) User Guide, Version 2. Environmental Protection Agency, Office of Health and Environmental Assessment, Office of Research and Development, data base (Draft).

EPA (U.S. Environmental Protection Agency) (1993a) Wildlife Exposure Factors Handbook, Vol. I and II. EPA report EPA/600/R-93/187 a & b.

EPA (U.S. Environmental Protection Agency) (1993b) Health Effects Assessment Summary Tables. EPA/540/R-93/058, Office of Solid Waste and Emergency and Remedial Response, Washington, DC.

EPA (U.S. Environmental Protection Agency) (1996) Proposed Guidelines for Ecological Risk Assessment. EPA/630/R-95/002B, Risk Assessment Forum, Washington, DC.

ESRI (Environmental Systems Research Institute) (1989) Triangulated Irregular Networks. ARC/Info User's Manual, Redlands, CA.

Esselink H, van der Geld M, Jager P, Posthuma-Trumpie A, Zoun F, Baars J (1995) Biomonitoring Heavy Metals Using the Barn Owl (*Tyto alba guttata*): Sources of Variation Especially Relating to Body Condition. Arch Environ Contam Toxicol 28:471-486.

Ferenbaugh RW, Meyers OB, Ebinger MH, Gallegos AF, Breshears DD (1996) Ecological Risk Assessment Approach For Los Alamos National Laboratory. Los Alamos National Laboratory report LA-UR-96-766.

Forsman ED, Meslow EC (1985) Old-growth forest retention for spotted owls - how much do they need? Pages 58-59 in R. J. Gutierrez and A. B. Carey, eds., Ecology and management of the spotted owl in the Pacific Northwest. USDA Forest Service Gen. Tech. Rpt. PNW - 185, Portland, OR.

Franke C, Studinger G, Berger G, Bohling S, Bruckmann U, Cohors-Fresenborg D, Johncke U (1994) The Assessment of Bioaccumulation. Chemosphere 29(7):1501-1514.

Fresquez PA, Mullen MA, Ferenbaugh JK, Perona RA (1996) Radionuclides and radioactivity in soils within and around Los Alamos National Laboratory, 1974 through 1994: concentrations, trends and dose comparisons. Los Alamos National Laboratory report LA-13149-MS.

Gallegos AF (1996) Documentation and Utilization of the Ecological Transport Model (BIOTRAN.2) Part 1 of 2 Parts, Los Alamos National Laboratory report (Draft).

Ganey L (1992) Food Habits of Mexican spotted owls in Arizona. Wilson Bull 104(2):321-326.

Gonzales GJ, Newell PG (1996) Ecotoxicological Screen of Potential Release Site 50-006(d) of Operable Unit 1147 of Mortandad Canyon and Relationship to the Radioactive Liquid Waste Treatment Facilities Project. Los Alamos National Laboratory report LA-13148-MS.

Gonzales GJ, Robinson RJ, Cross S, Nottleman H, Foxx T (1996) Literature review and [threatened and endangered] species habitat use documentation. Los Alamos National Laboratory report LA-UR-96-3526.

Gonzales GJ, Saladen MT, Hakonson TE (1995) Effects of pocket gopher burrowing on cesium-133 distribution in engineered test plots. J Environ Qual 24:1056-1062.

Grodzinska K, Godzik B, Darowska E, Pawlowska B (1987) Concentration of Heavy Metals in Trophic Chains of Niepolomice Forest, S. Poland. Ekol. Pol. 35:327-344. In Laskowski R: 1991 Are the Top Carnivores Endangered by Heavy Metal Biomagnification? Oikos 60:387-390.

Hakonson TE, Martinez JL, White GC (1982) Disturbances of low level waste site covers by pocket gophers. Health Phys 42(6):868-871.

Heath RG, Spann JW, Hill EF, Kreitzer JF (1972) Comparative dietary toxicities of pesticides to birds. US Fish Wild Serv, Special Sci Rpt, Wildlife No. 152, Washington, D.C.

Hegstrom LJ, West SD (1989) Heavy metal accumulation in small mammals following sewage sludge application to forests. J Environ Qual 18:345-349.

- Heinz GH, Hoffman DJ, Gold LG (1989) Impaired Reproduction of Mallards Fed an Organic Form of Selenium. *J. Wildl. Manage.* 53:418-428.
- Hill CH, Matrone G (1970) Chemical Parameters in the Study of In-Vitro and In-Vitro Interactions of Transition Elements. *Fed. Proc.* 29(4):1474-1481.
- Hill EF, Camardese MB (1986) Lethal dietary toxicities of environmental contaminants and pesticides to coturnix. US Fish and Wildlife Service technical report No. 2.
- Hill EF, Heath RG, Spann JW, Williams JD (1975) Lethal dietary toxicities of enviral pollutants to birds. Special scientific report, Wildlife No. 191, Washington, D.C.
- Hudson RH, Tucker RK, Haegele MA (1984) Handbook of Toxicity of Pesticides to Wildlife. 2nd ed., U.S. Fish and Wildlife Serv, Resource Pub. 153.
- IAEA (International Atomic Energy Agency) (1992) Effects of Ionizing Radiation on Plants and Animals at Levels Implied by Current Radiation Standards. Technical Report Series No. 332 Vienna, Austria.
- Interactive Software Services (1992) INTERACTER, The Portable Fortran 77 User-interface Development System. Interactive Software Services Ltd., Stafford, England.
- Johnson Jr. D, Mehring Jr. AL, Titus HW (1960) Tolerance of Chickens for Barium. *Proc Soc Exp Biol Med* 104:436-438.
- Johnson TH (1993) Topographic model of potential spotted owl habitat in New Mexico. New Mexico Dept Game and Fish contract 80-516.6-56.
- Keller DC, Risberg D (1995) Biological and Floodplain/Wetland Assessment for the Dual-Axis Radiographic Hydrodynamics Test Facility (DARHT). Los Alamos National Laboratory report LA-UR-95-647.
- LANL (Los Alamos National Laboratory) (1995) Integrated Ecological Risk Assessment and Hazards Analysis Pilot Project for the Proposed Waste Treatment and Storage Facilities. Probabilistic Risk and Hazard Analysis Group, Technology and Safety Assessment Division, Los Alamos National Laboratory report LA-UR-95-255.
- LANL (Los Alamos National Laboratory) (1994). Preliminary Ecological Screening Assessment for Operable Unit 1147. (Ebinger MH, Ferenbaugh RW, Gallegos AF, Hansen WR, Myers OB, Wenzel WJ) Los Alamos National Laboratory report LA-UR-94-3885.
- LANL (Los Alamos National Laboratory) (1993) Installation Work Plan for Environmental Restoration. Revision 3, Los Alamos National Laboratory report LA-UR-93-3987.
- Laskowski R (1991) Are the Top Carnivores Endangered by Heavy Metal Biomagnification? *Oikos* 60:387-390.
- Leidy RB (1980) Aquatic Organisms. pp 120-134 In: Introduction to Environmental Toxicology, Guthrie E F, Perry J J (Eds), Elsevier North Holland, Inc.
- Lepore PD, Miller RF (1964) Embryonic Viability as Influenced by Excess Molybdenum in Chicken Breeder Diets. *Proc Soc Exp Biol Med* 118:155-156.
- Lillie RJ, Cecil HC, Bitman J, Fires GF, Verrett J (1975) Toxicity of certain polychlorinated and polybrominated biphenyls on reproductive efficiency of caged chickens. *Poult Sci* 54:1500-1555.
- Longcore JR, Samson FB, Whittendale TW (1971) DDT thins eggshells and lowers reproductive success of captive black ducks. *Bull Envir Contam Toxicol* 6(6):485-490.
- Longmire PA, Reneau SL, Watt PM, McFadden LD, Gardner JN, Duffy CJ, Ryt RT (1996) Natural background geochemistry, geomorphology, and pedogenesis of selected soil profiles and Bandelier Tuff at Los Alamos, New Mexico.

Los Alamos National Laboratory report LA-12913-MS.

Ma WC (1987) Heavy metal accumulation in the mole, *Talpa europea*, and earthworms as an indicator of metal bioavailability in terrestrial environments. *Bull Environ Contam Toxicol* 30:424-427.

Marcot BB, Holthausen R (1987) Analyzing population viability of the spotted owl in the Pacific Northwest. *Transactions of the Conference on North American Wildlife and Natural Resources* 52:333-347.

Martin AC, Zim HS, Nelson AL (1961) *American Wildlife and Plants*. Dover Publications, Inc., New York.

Mehring Jr. AL, Brumbaugh JH, Sutherland AJ, Titus HW (1960) The Tolerance of Growing Chickens for Dietary Copper. *Poult Sci* 39:713-719.

Nuorteva P (1988) Tutkimuksia metallien osuudesta metsia tuhoavassa monistressisairaudessa. (Finnish) (The Role of Metals in the Multistress Disease Killing Forests in Europe), *Lounais-Hameen Luonto* 75:62-76. In: Laskowski R, 1991 Are the Top Carnivores Endangered by Heavy Metal Biomagnification? *Oikos* 60:387-390.

Oh SH, Nakaue H, Deagen JT, Whanger PD, Arscott GH (1979) Accumulation and Depletion of Zinc in Chick Tissue Metallothionein. *J Nutr* 109:1720-1729.

Opresko DM, Sample BE, Suter III GW (1994) Toxicological Benchmarks for Wildlife: 1994 Revision. Oak Ridge National Laboratory report ES/ER/TM-6/R1.

Peters RH (1993) *The Ecological Implications of Body Size*. Cambridge University Press, New York.

Sample BE, Suter II GW (1994) Estimating Exposure of Terrestrial Wildlife to Contaminants. Oak Ridge National Laboratory report ES/ER/TM-125.

Sample BE, Baron LA, Jackson BL (1995) Preliminary Assessment of the Ecological

Risks to Wide-ranging Wildlife Species on the Oak Ridge Reservation. Oak Ridge National Laboratory report DOE/OR/01-1407&D1.

Salford Software Limited (1994) FTN77/x86tm Reference Manual. Vol 1 and 2 University of Salford, Salford England.

Scott ML, van Tienhoven A, Holm ER, Reynolds RE (1960) Studies on the Sodium, Chlorined, and Iodine Requirements of Young Pheasants and Quail. *J Nutrition* 71:282-288.

Shane SM, Young RJ (1968) Renal and Parathyroid Changes Produced by High Calcium Intake in Growing Pullets. *Avian Disease* 13:558-567.

Shore RF, Douben PE (1994) The ecotoxicological significance of cadmium intake and residues in terrestrial small mammals. *Ecotox and Environ Safety* 29:101-112.

Stahl JL, Greger JL, Cook ME (1990) Breeding-hen and Progeny Performance When Hens Are Fed Excessive Dietary Zinc. *Poultry Sci* 69:259-263.

Smith GJ, Anders VP (1989) Toxic Effects of Boron on Mallard Reproduction. *Envir Toxicol Chem* 8:943-950.

Tiebout HM, Brugger KE (1995) Ecological Risk Assessment of Pesticides for Terrestrial Vertebrates: Evaluation and Application of the U.S. Environmental Protection Agency's Quotient Model. *Conserv Biol* 9(6):1605-1618.

Vohra P, Kratzer FH (1968) Zinc, Copper, and Manganese Toxicities in Turkey Poults and their Alleviation by EDTA. *Poult Sci* 47:699-703.

Walker CH (1990) Kinetic Model to Predict Bioaccumulation of Pollutants. *Funct Ecol* 4:295-301. In Laskowski R: 1991 Are the Top Carnivores Endangered by Heavy Metal Biomagnification? *Oikos* 60:387-390.

Weber CW, Reid BL (1968) Nickel Toxicity in Growing Chicks. *J. Nutr.* 95:612-616.

Willamo R, Nuorteva P (1987) The Role of Heavy Metals in Forest Die-Off. In Anttila P, Kauppi P (eds); Symp Finnish Res Proj Acidification (HAPRO) Ministry of the Environment, Ministry of Agriculture and Forestry, pp 64-67 In Laskowski R: 1991 Are the Top Carnivores Endangered by Heavy Metal Biomagnification? *Oikos* 60:387-390.

WESTON (Roy F Weston, Inc) (1995) Travis Air Force Base Remedial Investigation Report, East Industrial Operable Unit; Critical Toxicity Values for Avian Receptors Travis Air Force Base, CA.

White DH, Finley MT, Ferrell JF (1978) Histopathological Effects of Dietary Cadmium on Kidneys and Testes of Mallard Ducks. *J. Toxicol. Environ. Health.*

Whitworth MR, Pendleton GW, Hoffman DJ, Camardese MB (1991) Effects of Boron and Arsenic on the Behaviour of Mallard Ducklings. *Envir Toxicol Cont* 10(7):911-916.

Wolbarst AB, Mauro J, Anigstein R, Back D, Bartlett JW, Beres D, Chan D, Clark ME, Doehnert M, Durman E, Hay S, Hull HB, Lailas N, MacKinney J, Ralston L, Tsirigotis PL (1996) Technical basis for EPA's proposed regulation on the cleanup of sites contaminated with radioactivity. *Health Phys* 71(5):644-660.

APPENDIX



Table A-1. Basic program used to label grid cells and to generate x- and y-coordinate values by grid cell.

```
REM GRID Program
REM This program generates the label id for the rows and columns of the grid
REM It also generates the x,y coordinate of the center of each grid cell.
REM The input #1 file should contain the x minimum and y minimum values.
REM The user must edit the program with the input and output filename.
REM The user must input the number of rows and columns needed for the grid.
REM This information is required at the DO WHILE statements.
countr = 0
OPEN "c:\<filename>" FOR INPUT AS #1
OPEN "c:\<filename>" FOR OUTPUT AS #2
  INPUT #1, x, y
  LET yo = y
  DO
    LET countr = countr + 1
    LET rowo = countr
    LET countc = 0
    LET xo = x
    DO WHILE (countc) <= 259
      LET countc = countc + 1
      LET colo = countc
      WRITE #2, rowo, colo, xo, yo
      LET xo = xo + 100
    LOOP
    LET yo = yo + 100
  LOOP WHILE countr <= 199
```

Table A-2. Reference doses (RfDs) used in the preliminary ecological risk assessment of the Mexican Spotted owl at the Los Alamos National Laboratory.

ANALYTE	NOAEL (mg/kg/d)	Reference	Test Species	Chemical Form	Endpoint, Comment and/or Test Species	Comparison NOAEL (mg/kg/d)	Reference to Comparison Value
Inorganics							
Aluminum	109.700	Carriere et al., 1986	ringed dove	Al (SO4)	reproduction		
Antimony	0.035	LANL, 1994.				0.035=rat LOAEL, whole body & blood	LANL, 1994 and EPA, 1996
Arsenic	1.160	Whitworth et al., 1991 <u>In:</u> Weston, 1995.	1-d mallard		Chronic NOAEL, behavioral effects	1) 0.001; 2) 0.009 mg/L = human oral NOAEL	1) LANL, 1994; 2) EPA, 1996
Barium	20.800	Johnson et al., 1960	1-day chicks	hydroxide	mortality	0.21= oral human NOAEL for BaCn, cardiovasc. target	LANL, 1994
Boron	28.800	Smith and Anders, 1989	mallard ducks	boric acid	reproduction	28.8	
Beryllium	0.540	LANL, 1994			Oral rat NOAEL (EPA, 1996)	= oral rat NOAEL (EPA, 1996)	
Cadmium	1.450	White et al., 1978	mallard ducks	chloride	reproduction	1. 0.005; 2. 19.1 = oral NOAEL in rat	1. EES-15 Append; 2. EPA, 1996
Calcium	24.000	Shane and Young, 1968 <u>In:</u> Weston, 1995	White leghorn chick		Chronic death from renal failure	None	
Chromium III	3.810	Hill and Matrone, 1970 <u>In:</u> Weston, 1995	3-wk chick		Chronic weight loss and mortality	1. 1468; 2. 5% = oral NOAEL, rat	1. LANL, 1994; 2. EPA, 1996
Chromium VI	3.800	Hill and Matrone, 1970 <u>In:</u> Weston, 1995	3-wk chick		Chronic NOAEL, body weight	2.4 = oral NOAEL, rat	LANL, 1994 /EPA, 1996

Table A-2 (cont.)

ANALYTE	NOAEL (mg/kg/d)	Reference	Test Species	Chemical Form	Endpoint, Comment and/or Test Species	Comparison NOAEL (mg/kg/d)	Reference to Comparison Value
Inorganics							
Cobalt							
Copper	46.970	Mehring et al., 1960	1 day chicks	oxide	growth, mortality	5.3 mg = single dose NOAEL, human	
Cyanide	10.800	LANL, 1994				oral NOAEL, rat	
Fluorides	4.500	LANL, 1994				0.06 = oral NOAEL, human	
Hydrogen Fluoride							
Iron							
Lead	1.130	Edens et al., 1976	Japanese quail	acetate	reproduction	0.9	LANL, 1994
Lithium	480.000	Opresko et al., 1994	red-winged blackbird	LiCl ₂	NOAEL = [15,000 ppm (feeding dose) x bw]/bw; no endpoint stated		
Magnesium	32.000	Opresko et al., 1994	Japanese quail		NOAEL = [1,000 ppm (feeding dose) x bw]/bw; endpoint=physiology	no EPA, 1996 value	
Manganese	9.140	Vohra and Kratzer, 1968 <u>In</u> : Weston, 1995	turkey poults		Acute NOAEL	1) 0.14=oral human NOAEL; 2) 0.005	1) EPA, 1996; 2) LANL, 1994
Mercury	0.064	Opresko et al., 1994	Japanese quail	HgCl	NOAEL = [2 ppm (feeding dose) x bw]/bw; endpoint=physiology	1) 0.32; 2) 0.0064	1) LANL, 1994; 2) ORNL, CH ₃ Hg NOAEL for mallard
Molybdenum	0.280	Lepore and Miller, 1964 <u>In</u> : Weston, 1995	7-mo hen		50% embryo mortality [LD ₅₀] x 0.01		

Table A-2 (cont.)

Analyte	NOAEL (mg/kg/d)	Reference	Test Species	Chemical Form	Endpoint, Comment and/or Test Species	Comparison NOAEL (mg/kg/d)	Reference to Comparison Value
Nickel	0.676	Weber and Reid, 1968 <u>In</u> : Weston, 1995	1-d chick		wt. gain	1) 5.0; 2)100 ppm = rat diet NOAEL	1) LANL, 1994; 2) EPA, 1996
Nitrate	1.600	LANL, 1994					
Nitrite	1.000	LANL, 1994				10 ppm = oral human NOAEL, methemoglobinemia	
Potassium		LANL, 1994					
Selenium	0.400	Heinz et al., 1989	mallard duck		reproduction	1. 0.015; 2. 0.853 mg/d = human NOAEL, whole body	1. LANL, 1994; 2. EPA, 1996
Silver	0.344	___ and Jensen, 1975 <u>In</u> : Weston, 1995	1-d chick		Chronic growth and mortality	0.0014	LANL, 1994
Sodium	124.000	Scott et al., 1960 <u>In</u> : Weston, 1995	1-d quail		Chronic NOAEL, "no effects"	20.4=oral NOAEL in rat, CNS	EPA, 1996
Thallium	1.200	Opresko et al., 1994	golden eagle	TiSO ₄	LD ₅₀ x 0.01	1) 0.22=oral NOAEL, rat (ThO ₂); 2) 0.192=LC ₅₀ pheasant.	1) Hudson et al., 1984 <u>In</u> : Weston, 1995.
Vanadium	0.320	Opresko et al., 1994	mallard duck	VaSO ₄	NOAEL = [10 ppm (feeding dose) x bw]/bw; endpoint=blood chemistry	5 ppm=rat oral diet NOAEL	EPA, 1996

Table A-2 (cont.)

Analyte	NOAEL (mg/kg/d)	Reference	Test Species	Chemical Form	Endpoint, Comment and/or Test Species	Comparison NOAEL (mg/kg/d)	Reference to Comparison Value
Zinc	1.935	Stahl et al., 1990	white leghorn hens		reproduction	1) 10.1="chronic "no effects" NOAEL in 1-d chicks; 2) 0.2231="acute dose" x 0.01 in great horned owl; 3) 0.1	1) Oh et al., 1979 In: Weston, 1995; 2) Opresko et al., 1994 ; 3) LANL, 1994

Volatile Organic Compounds	NOAEL (mg/kg/d)	Reference	Test Species	Chemical Form	Endpoint, Comment and/or Test Species	Comparison NOAEL (mg/kg/d)	Reference to Comparison Value
1,1,1,2-Tetrachloroethane						89.300	LANL, 1994
1,1,1-Trichloroethane							
1,1,2,2-Tetrachloroethane							
1,1,2-trichloro-1,2,2-trifluoroethane						273.000	LANL, 1994
1,1,2-Trichloroethane						3.900	LANL, 1994
1,1-Dichloroethane							
1,1-Dichloroethene						9.000	LANL, 1994
1,2,3-Trimethyl benzene(d)							
1,2,4-Trimethylbenzene							
1,2-di bromo-3-Chloropropane							
1,2-Dichloroethane							
1,2-Dichloropropane							
1,3,5-Trimethylbenzene							
1,3- Dichloropropene	3.0	LANL, 1994					
2-Butanone (Methyl ethyl ketone)	1771.0	LANL, 1994					
2-Hexanone(g)							
3-carene(d)							

Table A-2 (cont.)

Volatile Organic Compounds	NOAEL (mg/kg/d)	Reference	Test Species	Chemical Form	Endpoint, Comment and/or Test Species	Comparison NOAEL (mg/kg/d)	Comparison Value Reference
4-hydroxy-4-methyl-2-pentanone(d)							
4-isopropyltoluene							
4-Methyl-2-pentanone (MIK)							
Acetone	565.0	Hill and Camardese, 1986	Japanese quail	acute toxicity			
Benzene							
Benzoic acid	4.46	LANL, 1994					
Bromobenzene(d)							
Bromochloromethane(d)							
Bromodichloromethane	17.9	LANL, 1994					
Bromoform	17.9	LANL, 1994					
Bromomethane	1.4	LANL, 1994					
Carbon disulfide	11.0	LANL, 1994					
Carbon tetrachloride	0.71	LANL, 1994					
Chlorobenzene	19.0	LANL, 1994					
Chloroethane							
Chloroethane							
Chloroform	12.9	LANL, 1994					
Chloromethane							
cis-1,2-Dichloroethene							
cis-1,3-Dichloropropene							
Dibromochloromethane	21.4	LANL, 1994					
Dibromoethane							
dibromomethane(d)							
Dichlorodifluoromethane (1,2)-(1,3)-(2,2)	15.0	LANL, 1994					
Dichloropropane (1,2)							

Table A-2 (cont.)

Volatile Organic Compounds	NOAEL (mg/kg/d)	Reference	Test Species	Chemical Form	Endpoint, Comment and/or Test Species	Comparison NOAEL (mg/kg/d)	Comparison Value Reference
Ethyl benzene	97.1	LANL, 1994					
hexanone (methyl butyl ketone)(d)							
Isopropyl benzene							
Limonene(d)							
Methanol	500.0	LANL, 1994					
Methyl Iodide(d)							
Methylene Chloride	5.85	LANL, 1994					
n-butylbenzene(d)							
n-Hexane							
Nitrotoluenes							
o-Chlorotoluene	20.0	LANL, 1994					
p-Chlorotoluene(d)							
propyl benzene(d)							
Styrene	200.0	LANL, 1994					
Tetrachloroethylene	14.0	LANL, 1994					
Toluene	223.0	LANL, 1994					
trans-1,2-Dichloroethene	17.0	LANL, 1994					
Vinyl Chloride							
Xylene (Total)	179.0	LANL, 1994					
Trichloropropane (1,2,3)	5.71	LANL, 1994					
(2,4-Dichlorophenoxy) propionic acid (dichloroprop)(d)							
1,2,4-Trichlorobenzene	14.8	LANL, 1994					
1,2-Dichlorobenzene	85.7	LANL, 1994					
1,3-Dichlorobenzene							
1,4-Dichlorobenzene							
1,4-methan Azulene, decahydro-4,4,8(d)							
2,2-Oxybis(1-chloropropane) (bis[2-chloroisopropyl]ether)							
2,4,5 -Trichlorophenoxyacetic acid	3.0	LANL, 1994					

Table A-2 (cont.)

Volatile Organic Compounds	NOAEL (mg/kg/d)	Reference	Test Species	Chemical Form	Endpoint, Comment and/or Test Species	Comparison NOAEL (mg/kg/d)	Comparison Value Reference
2,4,5-Trichlorophenoxy Propionic Acid	0.75	LANL, 1994					
2,4,5-Trichlorophenol	100.0	LANL, 1994					
2,4,6-Trichlorophenol							
2,4- D	0.8	Hudson et al., 1984		chuckar	mortality		
2,4-DB	8.0	LANL, 1994					
2,4-Dichlorophenol	0.3	LANL, 1994					
2,4-Dimethylphenol	50.0	LANL, 1994					
2,4-Dinitrophenol	2.0	LANL, 1994					
2- Nitrophenol(d)							
2-Chloronaphthalene							
2-Chlorophenol	5.0	LANL, 1994					
2-Methyl-4,6-dinitrophenol(d)							
2-Methylnaphthalene(d)							
trans-1,3-Dichloropropene							
Trichloroethene							
Trichlorofluoromethane	349.0	LANL, 1994					
2-Methylnaphthalene(g)							
2-Methylphenol (o-cresol)	50.0	LANL, 1994					
2-Nitroaniline, (o-Nitroaniline)							
2-Nitroaniline							
2-Nitrophenol(g)							
2-Nitrophenol(g)							
2H-1-benzo-pyran-2-one(d)							
3,3'-Dichlorobenzidine							
3-Nitroaniline(m-nitroaniline)(g)							
3-Nitroaniline							
4-Chloro-3-methylphenol (p-chloro-m-cresol)							
4,6-Dinitro-2-methylphenol(g) (4,6-dinitro-o-creso)							

Table A-2 (cont.)

Volatile Organic Compounds	NOAEL (mg/kg/d)	Reference	Test Species	Chemical Form	Endpoint, Comment and/or Test Species	Comparison NOAEL (mg/kg/d)	Comparison Value Reference
4- Nitrophenol							
4-Bromophenyl phenyl ether(d)							
4-Bromophenyl-phenylether(g)							
4-Chloro o-tolyoxyacetic acid(d)							
p-Chloroaniline	12.5	LANL, 1994					
4-Chlorophenyl phenyl ether(d)							
4-Chlorophenyl phenylether(g)							
4-Methylphenol (p-cresol)	5.0	LANL, 1994					
4-Nitroaniline(p-nitroaniline)(g)							
4-Nitroaniline							
Acenaphthene	175.0	LANL, 1994					
Acenaphthylene(d)							
Acenaphthylene(g)							
Adipic ester(d)							
Aldrin	0.025	LANL, 1994					
Alpha-BHC							
Aniline							
Anthracene	1000.0	LANL, 1994					
Arochlors (mixed)	0.4759					0.007	LANL, 1994
Aroclor-1248	0.00272	Cecil et al., 1974	chicken		chronic reproductive		
Aroclor-1254	0.0052	Lillie et al., 1975	leghorn (pullets)		mortality		
Azobenzene							
Benzene acetic acid(d)							
Benzidine							
Benzo[a]anthracene							
Benzo[a]pyrene							
Benzo[b]fluoranthene							
Benzo[ghi]perylene							
Benzo[k]fluoranthene							
Benzyl alcohol(d)							

Table A-2 (cont.)

Volatile Organic Compounds	NOAEL (mg/kg/d)	Reference	Test Species	Chemical Form	Endpoint, Comment and/or Test Species	Comparison NOAEL (mg/kg/d)	Comparison Value Reference
Benzyl alcohol							
Beta-BHC							
Bis(2-ethylhexyl)phthalate							
Bis(2chloroethoxy)methane(g)							
Bis-(2-chloroethyl)ether							
Butyl benzyl phthalate						159.0	LANL, 1994
Carbazole							
Cetyl alcohol(d)							
Chlordane						0.055	LANL, 1994
Chlorophenoxy acetic acid (2-methy-4)							
Chrysene							
Dalapon						8.45	LANL, 1994
DDD	0.236	Hill et al., 1975	ring-necked pheasant		mortality	165.0	LANL, 1994
DDE	0.00224	Longcore et al., 1971	black duck		egshell thinning	42.0	LANL, 1994
DDT	0.0066	Davison and Sell 1974	mallard		reproduction	0.05	LANL, 1994
delta-BHC(d)							
Di-n-butylphthalate							
Di-n-octyl phthalate						175.0	LANL, 1994
Dibenzo[a,h]anthracene							
Dibenzofuran(d)							
Dicamba	3.0	LANL, 1994.					
Dieldrin	0.24	Heath et al., 1972				0.005	LANL, 1994
Diethylphthalate	750.0	LANL, 1994					
Dimethyl phthalate	1000.0	LANL, 1994					
Dimethylformamide							

Table A-2 (cont.)

Volatile Organic Compounds	NOAEL (mg/kg/d)	Reference	Test Species	Chemical Form	Endpoint, Comment and/or Test Species	Comparison NOAEL (mg/kg/d)	Comparison Value Reference
Dinoseb	1.0	LANL, 1994					
Endosulfan I & II	0.15	LANL, 1994					
Endosulfan sulfate(d)							
Endosulfan							
Endrin	0.025	LANL, 1994					
Ethyl acetate	900.0	LANL, 1994					
Ethylene glycol	200.0	LANL, 1994					
Fluoranthene	125.0	LANL, 1994					
Fluorine	125.0	LANL, 1994					
Hepachlor Epoxide	0.013	LANL, 1994					
Hepachlor	0.150	LANL, 1994					
Hexachlorobenzene	0.080	LANL, 1994					
Hexachlorobutadiene							
Hexachlorocyclopentadiene	7.0	LANL, 1994					
Hexachloroethane	1.0	LANL, 1994					
Hexadecanoic acid(d)							
Indeno[1,2,3-cd]pyrene							
Isophorone	150.0	LANL, 1994					
Lindane (gamma BHC)	0.33	LANL, 1994					
Mecoprop (MCP)	3.0	LANL, 1994					
Mecoprop(d)							
Methoxychlor	5.01	LANL, 1994					
N-Nitrosodi-N-propylamine							
N-Nitrosodimethylamine							
N-Nitrosodiphenylamine							
Naphthalene							

Table A-2 (cont.)

Volatile Organic Compounds	NOAEL (mg/kg/d)	Reference	Test Species	Chemical Form	Endpoint, Comment and/or Test Species	Comparison NOAEL (mg/kg/d)	Reference to Comparison Value
Nitrobenzene	4.6	LANL, 1994					
Octacosane(d)							
Octadecanoic acid(d)							
Octamethyleyclotetrasiloxane(d)							
PCB (aroclor)	0.007	LANL, 1994					
Pentachlorophenol	3.0	LANL, 1994					
Phenanthrene carboxylic acid(d)							
Phenanthrene(d)							
Phenanthrene(g)							
Phenol	60.0	LANL, 1994					
Phthalate ester(d)							
Pyrene	75.0	LANL, 1994					
Tetradecanoic acid(d)							
Toxaphene							
Vinyl Acetate	100.0	LANL, 1994					
High Explosives							
1,3,5-TNB (trinitrobenzene)	0.51	LANL, 1994					
1,3-DNB (dinitrobenzene)	0.4	LANL, 1994					
2,4,6-TNT (trinitrotoluene)	0.5	LANL, 1994					
2,4-DNT (dinitrotoluene)	0.2	LANL, 1994					
2,6-DNT (dinitrotoluene)							
2-amino-2,6-DNT (aminodinitrotoluene)(g)							
2-amino-4,6-Dinitrotoluene(d)							

Table A-2 (cont.)

High Explosives	NOAEL (mg/kg/d)	Reference	Test Species	Chemical Form	Endpoint, Comment and/or Test Species	Comparison NOAEL (mg/kg/d)	Reference to Comparison Value
4-amino-2,6-DNT (amino-dinitrotoluene)(g)							
Ammonium nitrate(g)							
Barium nitrate (soluble barium)							
CEF (tri[b-chloroethyl]phosphate)(g)							
DPA (diphenylamine)	2.5	LANL, 1994					
HMX (cyclotetramethylenete-tranitramine)	50.0	LANL, 1994					
Nitrocellulose (non-toxic)(g/k)							
Nitromethane(g)							
NP (bis[2,2-dinitropropyl]acetyl/formal)(g)							
PETN (pentaerythritol tetra-nitrate)							
RDX (trimethylenetri-nitramine)	0.30	LANL, 1994					
TATB (triaminotrinitrobenzene)(g)							
Tetryl (N-methyl-N,2,4,6-tetranitrobenzeneamine)							

Table A-2 (cont.)

Radionuclide	SAL (pCi/g)	Reference	Radionuclide	SAL (pCi/g)	Reference
Americium-241	17.0	FIMAD	Ruthenium-106	14.0	FIMAD
Carbon-14	41.0	FIMAD	Sodium-22	1.3	FIMAD
Cerium-144	56.0	FIMAD	Strontium-90	5.9	FIMAD
Cesium-134	1.8	FIMAD	Technetium-99	38.0	FIMAD
Cesium-137	4.0	FIMAD	Thorium-228	1.7	FIMAD
Cobalt-57	40.0	FIMAD	Thorium-230	5.0	FIMAD
Cobalt-60	0.9	FIMAD	Thorium-232	5.0	FIMAD
Gross Alpha Activity			Tritium	820.0	FIMAD
Iodine-129	41.0	FIMAD	Uranium-233	86.0	FIMAD
Manganese-54	3.4	FIMAD	Uranium-234	86.0	FIMAD
Plutonium-238	20.0	FIMAD	Uranium-235	18.0	FIMAD
Plutonium-239	18.0	FIMAD	Uranium-238	59.0	FIMAD
Potassium-40	12.0	FIMAD	Depleted Uranium	59.0	FIMAD
Radium-226	5.0	FIMAD	Uranium	66.0	FIMAD
Radium-228	5.0	FIMAD			

Table A-3. Hazard index (cumulative hazard quotient) for each of 100 randomly selected potential nest sites of the Mexican spotted owl in Ecological Exposure Unit 21.

Nest Site Location		Hazard Index	Nest Site No.
Column	Row		
53	46	1.06322	1
39	50	0.216764	2
44	45	5.34E-02	3
66	45	0.520538	4
39	50	0.144044	5
47	49	0.104409	6
24	49	9.19E-03	7
19	49	6.55E-03	8
67	41	0.617791	9
32	44	3.72E-02	10
57	40	0.687549	11
49	39	7.96E-02	12
37	48	0.195895	13
69	42	0.205372	14
25	50	5.95E-02	15
37	42	2.36E-02	16
23	44	6.89E-03	17
59	44	0.874638	18
39	52	0.159943	19
50	44	0.179247	20
28	50	1.76E-02	21
52	38	0.852956	22
45	41	0.111726	23
34	42	4.84E-02	24
59	40	0.620007	25
20	49	2.35E-02	26
58	42	0.511308	27
24	43	3.72E-02	28
31	48	1.78E-02	29
42	46	5.80E-02	30
37	54	1.76E-02	31
21	51	7.63E-03	32
29	49	1.07E-02	33
31	41	8.86E-03	34
29	48	1.04E-02	35
38	52	1.73E-02	36
76	32	0.509501	37
29	45	2.28E-02	38
39	50	2.90E-02	39
34	44	1.18E-02	40
24	42	6.63E-03	41
30	56	1.24E-02	42
50	38	0.103932	43
15	46	4.79E-03	44
63	44	0.747317	45
31	49	4.48E-02	46
67	42	0.409567	47
39	53	0.151297	48
54	45	0.344775	49

Table A-3 (cont.)

Nest Site Location		Hazard Index	Nest Site No.
Column	Row		
45	42	2.81E-02	50
37	50	0.446934	51
29	45	1.93E-02	52
24	50	8.71E-03	53
18	49	6.24E-03	54
65	37	0.615521	55
42	46	0.115947	56
68	37	3.72E-02	57
34	47	0.400373	58
51	47	0.360547	59
51	47	3.54E-02	60
31	40	3.06E-02	61
28	42	8.23E-03	62
63	40	0.78044	63
68	43	7.82E-02	64
16	46	6.02E-02	65
20	49	8.99E-03	66
60	40	0.682506	67
42	39	0.110792	68
26	46	1.56E-02	69
14	53	5.51E-03	70
58	39	0.719411	71
25	51	3.67E-02	72
16	52	6.27E-03	73
20	52	7.33E-03	74
58	44	0.822677	75
53	37	8.11E-02	76
19	46	0.146623	77
36	44	4.60E-02	78
27	43	8.26E-03	79
51	42	0.44739	80
14	46	5.86E-03	81
29	43	1.01E-02	82
50	45	2.53E-02	83
51	41	1.85E-02	84
39	41	1.27E-02	85
68	44	0.770087	86
32	41	2.48E-02	87
75	40	0.410672	88
24	47	2.03E-02	89
18	47	6.01E-03	90
68	44	0.641103	91
60	40	7.04E-02	92
36	48	0.463727	93
47	49	0.206315	94
23	46	1.10E-02	95
74	35	0.416407	96
68	37	2.64E-02	97
40	44	0.237029	98
30	42	7.06E-02	99
76	38	0.184763	100

Table A-4. Hazard index (cumulative hazard quotient) for each of 100 randomly selected potential nest sites of the Mexican spotted owl in Ecological Exposure Unit 40.

Nest Site Location		Hazard Index	Nest Site No.
Column	Row		
115	122	3.19E-02	1
124	58	1.87E-03	2
105	79	3.76E-04	3
65	119	1.52E-03	4
145	121	3.99E-04	5
125	53	1.01E-03	6
67	114	1.40E-03	7
111	138	2.09E-03	8
73	144	7.70E-04	9
71	139	6.47E-04	10
74	114	3.03E-04	11
89	95	6.97E-05	12
131	54	8.66E-04	13
129	46	9.62E-04	14
76	112	2.53E-04	15
77	110	2.01E-04	16
113	137	6.35E-03	17
137	109	2.22E-03	18
90	101	5.96E-05	19
108	86	4.21E-04	20
65	141	8.58E-04	21
78	140	5.49E-04	22
122	117	1.86E-04	23
137	48	1.06E-03	24
160	36	9.96E-04	25
125	117	1.91E-04	26
117	72	7.87E-04	27
111	90	5.38E-04	28
123	67	9.37E-04	29
64	116	1.79E-03	30
129	136	1.02E-03	31
126	49	8.57E-04	32
95	101	1.01E-04	33
124	119	1.76E-04	34
127	133	6.22E-04	35
147	136	1.48E-03	36
122	134	5.17E-04	37
126	139	8.48E-04	38
139	47	8.74E-04	39
119	67	7.91E-04	40
106	100	1.97E-04	41
131	50	8.18E-04	42
64	142	7.13E-04	43
118	49	8.50E-04	44
122	58	7.21E-04	45
125	116	2.09E-04	46
75	144	5.78E-04	47
111	123	2.22E-04	48
167	131	1.71E-03	49

Table A-4 (cont.)

Nest Site Location		Hazard Index	Nest Site No.
Column	Row		
70	140	6.31E-04	50
126	60	7.48E-04	51
114	138	4.18E-04	52
78	107	1.25E-04	53
125	136	6.74E-04	54
84	139	6.16E-04	55
129	45	9.58E-04	56
154	129	4.04E-02	57
58	122	8.55E-04	58
91	91	9.08E-05	59
95	139	1.02E-03	60
115	71	7.67E-04	61
146	135	1.51E-03	62
126	54	9.33E-04	63
111	99	3.46E-04	64
127	58	9.41E-04	65
88	141	7.59E-04	66
161	40	1.05E-03	67
64	120	5.33E-04	68
65	117	5.25E-04	69
135	137	1.04E-03	70
119	54	7.55E-04	71
91	143	8.60E-04	72
144	135	1.18E-03	73
156	39	1.02E-03	74
124	56	7.75E-04	75
135	52	8.46E-04	76
93	143	1.04E-03	77
135	49	8.16E-04	78
117	56	7.10E-04	79
57	121	7.47E-04	80
72	110	3.05E-04	81
96	141	1.04E-03	82
138	112	1.98E-03	83
155	133	1.13E-03	84
143	132	8.77E-04	85
120	138	5.59E-04	86
68	145	1.23E-03	87
83	137	5.56E-04	88
95	89	1.55E-04	89
96	101	1.07E-04	90
121	64	7.85E-04	91
158	139	2.10E-03	92
98	100	1.29E-04	93
135	46	9.09E-04	94
114	140	4.37E-04	95
103	102	1.36E-04	96
74	112	2.84E-04	97
145	133	1.02E-03	98
106	140	5.87E-04	99
67	116	4.74E-04	100

Table A-5. Mean partial hazard quotient (HQ) by contaminant of potential ecological concern (COPEC) for the Mexican spotted owl at Ecological Exposure Unit 21.

Rank	COPEC	HQ	Mean Stnd Error	% of Total HI	No. Obs.
1	Cesium-137	3.01E-02	4.29E-02	15	100
2	Nickel	2.11E-02	2.96E-02	11	100
3	Plutonium-239	2.07E-02	3.00E-02	10	100
4	Aluminum	1.73E-02	2.25E-02	8.7	100
5	Uranium-234	1.43E-02	2.00E-02	7.2	100
6	Potassium-40	1.40E-02	1.70E-02	7.1	100
7	Calcium	1.36E-02	1.82E-02	6.9	100
8	Strontium-90	8.92E-03	1.28E-02	4.5	100
9	Thorium-228	7.06E-03	9.49E-03	3.6	100
10	Uranium-235	6.21E-03	8.68E-03	3.1	100
11	Vanadium	5.98E-03	7.76E-03	3.0	100
12	Radium-226	5.28E-03	7.15E-03	2.7	100
13	Magnesium	5.08E-03	6.55E-03	2.6	100
14	Manganese	4.51E-03	5.71E-03	2.3	100
15	Sodium	4.24E-03	5.54E-03	2.1	100
16	Zinc	3.07E-03	4.01E-03	1.6	100
17	Americium-241	2.72E-03	3.70E-03	1.4	100
18	Antimony	2.59E-03	3.67E-03	1.3	100
19	Lead	2.48E-03	3.14E-03	1.2	100
20	Thorium-232	2.00E-03	2.74E-03	1.0	100
21	Thorium-230	1.35E-03	1.85E-03	0.68	100
22	Plutonium-238	1.19E-03	1.72E-03	0.60	100
23	Barium	7.77E-04	1.00E-03	0.39	100
24	Aroclor 1260	4.45E-04	6.93E-04	0.22	100
25	Aroclor [Mixed-]	4.29E-04	6.94E-04	0.22	100
26	Uranium-238	3.21E-04	4.14E-04	0.16	100
27	Chromium	3.16E-04	4.02E-04	0.16	100
28	Cesium-134	2.99E-04	4.11E-04	0.15	100
29	Ruthenium-106	1.98E-04	3.09E-04	0.10	100
30	Silver	1.98E-04	2.40E-04	0.10	100
31	Arsenic	1.83E-04	2.37E-04	0.09	100
32	Beryllium	1.73E-04	2.21E-04	0.09	100
33	Mercury	1.56E-04	2.18E-04	0.08	100
34	Thallium	1.46E-04	2.30E-04	0.07	100
35	Molybdenum	1.38E-04	1.85E-04	0.07	100
36	Selenium	1.21E-04	1.42E-04	0.06	100
37	Manganese-54	1.20E-04	1.67E-04	0.06	100
38	Cobalt-60	1.18E-04	1.70E-04	0.06	100
39	Aroclor 1254	6.15E-05	1.09E-04	0.03	98
40	Sodium-22	4.38E-05	5.37E-05	0.02	100
41	Cadmium	4.17E-05	5.67E-05	0.02	100
42	Radium-228	3.06E-05	3.72E-05	0.02	64
43	Copper	2.97E-05	4.06E-05	0.01	100
44	Cobalt-57	1.42E-05	1.99E-05	0.01	100
45	Uranium	7.27E-06	9.36E-06	3.67E-03	100
46	Cerium-144	3.01E-06	4.61E-06	1.52E-03	100
47	Chromium	1.58E-06	2.14E-06	7.99E-04	68
48	Lithium	1.57E-06	2.07E-06	7.93E-04	100
49	Pyrene	1.16E-06	1.73E-06	5.84E-04	100
50	Fluoranthene	9.32E-07	1.40E-06	4.70E-04	100
51	Iodine-129	7.56E-07	9.88E-07	3.81E-04	100
52	Pentachlorophenol	5.74E-07	7.25E-07	2.90E-04	100
53	Tritium	5.54E-07	8.67E-07	2.79E-04	100
54	Benzoic acid	3.43E-07	4.28E-07	1.73E-04	100

Table A-5 (cont.)

Rank	COPEC	HQ	Mean Stnd Error	% of Total HI	No. Obs.
55	Boron	1.00E-07	1.99E-07	5.06E-05	98
56	Cyanide	9.93E-08	1.39E-07	5.01E-05	100
57	Chlorobenzene	4.10E-08	6.05E-08	2.07E-05	100
58	Fluorene	3.15E-08	4.75E-08	1.59E-05	100
59	Acenaphthene	2.86E-08	4.09E-08	1.44E-05	100
60	Phenol	1.67E-08	2.13E-08	8.45E-06	100
61	Anthracene	7.89E-09	1.19E-08	3.98E-06	100
62	Methylene chloride	4.74E-09	7.07E-09	2.39E-06	100
63	Acetone	2.28E-09	3.02E-09	1.15E-06	100
64	Technetium-99	1.42E-09	1.90E-09	7.15E-07	98
65	Toluene	1.31E-09	1.93E-09	6.60E-07	100
66	Di-n-octylphthalate	1.29E-09	1.93E-09	6.49E-07	87
67	Tetrachloroethylene	1.18E-09	1.62E-09	5.93E-07	100
68	Butyl benzyl phthalate	8.68E-10	1.10E-09	4.38E-07	100
69	Carbon disulfide	6.92E-10	8.82E-10	3.49E-07	68
70	Trichlorofluoromethane	3.00E-11	4.00E-11	1.51E-08	100
71	Styrene	6.10E-12	7.64E-12	3.08E-09	100

Table A-6. Mean partial hazard quotient (HQ) by contaminant of potential ecological concern (COPEC) for the Mexican spotted owl at Ecological Exposure Unit 40.

Rank	COPEC	HQ	Mean Std Error	% of Total HI	No. Obs.
1	Potassium-40	4.45E-04	1.85E-03	26	98
2	Radium-226	2.59E-04	1.07E-03	15	98
3	Calcium	1.61E-04	4.74E-04	9.6	100
4	Thorium-232	1.11E-04	4.60E-04	6.6	51
5	Antimony	7.72E-05	4.25E-04	4.6	100
6	Aluminum	7.11E-05	2.22E-04	4.2	100
7	Vanadium	5.93E-05	1.75E-04	3.5	100
8	Lead	5.27E-05	9.89E-05	3.1	100
9	Cesium-137	5.14E-05	1.89E-04	3.1	100
10	Manganese	4.74E-05	1.59E-04	2.8	100
11	Strontium-90	4.54E-05	1.52E-04	2.7	57
12	Magnesium	4.43E-05	1.39E-04	2.6	100
13	Plutonium-238	3.84E-05	2.13E-04	2.3	53
14	Zinc	3.71E-05	1.15E-04	2.2	100
15	Barium	2.97E-05	6.13E-05	1.8	100
16	Uranium-238	2.52E-05	4.73E-05	1.5	70
17	Nickel	2.12E-05	5.54E-05	1.3	100
18	Uranium-234	1.69E-05	3.29E-05	1.0	70
19	Thorium-228	1.43E-05	2.59E-05	0.85	22
20	Plutonium-239	1.08E-05	5.49E-05	0.64	53
21	Mercury	1.03E-05	4.79E-05	0.61	100
22	Chromium	5.73E-06	1.70E-05	0.34	100
23	Aroclor [Mixed-]	5.49E-06	1.81E-05	0.33	29
24	Arsenic	5.45E-06	1.50E-05	0.32	100
25	Selenium	4.75E-06	8.30E-06	0.28	100
26	Uranium-235	4.52E-06	1.07E-05	0.27	98
27	Aroclor 1260	3.68E-06	9.15E-06	0.22	20
28	Aroclor 1254	3.16E-06	1.08E-05	0.19	27
29	Cobalt-60	2.72E-06	1.20E-05	0.16	100
30	Silver	2.68E-06	5.65E-06	0.16	87
31	Beryllium	2.46E-06	7.51E-06	0.15	100
32	Copper	2.05E-06	5.54E-06	0.12	100
33	Americium-241	1.81E-06	6.56E-06	0.11	100
34	Cadmium	1.59E-06	4.49E-06	0.09	100
35	Sodium	1.58E-06	4.61E-06	0.09	100
36	Thallium	1.20E-06	1.89E-06	0.07	100
37	Radium-228	1.16E-06	1.56E-06	0.07	11
38	Sodium-22	8.14E-07	3.11E-06	0.05	98
39	Thorium-230	7.98E-07	1.18E-06	0.05	7
40	Ruthenium-106	5.70E-07	2.82E-06	0.03	97
41	Uranium	3.85E-07	8.76E-07	0.02	100
42	Cesium-134	3.45E-07	3.61E-07	0.02	24
43	Methoxychlor	1.81E-07	0.00E+00	0.01	1
44	DDE [p,p']	8.63E-08	0.00E+00	0.01	1

Table A-6 (cont.)

Rank	COPEC	HQ	Mean Stnd Error	% of Total HI	No. Obs.
45	Dieldrin	8.49E-08	7.09E-08	0.01	10
46	Cerium-144	6.32E-08	2.93E-07	0.004	99
47	DDT [p,p']	4.40E-08	7.59E-08	0.003	11
48	Manganese-54	3.16E-08	1.96E-08	0.002	35
49	Pentachlorophenol	2.26E-08	6.43E-08	0.001	16
50	Cyanide	1.19E-08	1.11E-08	0.001	25
51	Heptachlor epoxide	1.08E-08	0.00E+00	0.001	1
52	Aldrin	8.86E-09	1.37E-08	0.001	11
53	Endrin	5.50E-09	7.40E-09	3.3E-04	10
54	Cobalt-57	2.66E-09	9.12E-10	1.6E-04	19
55	Nitrobenzene	1.65E-09	2.11E-09	9.8E-05	24
56	Pyrene	1.32E-09	3.49E-09	7.8E-05	82
57	Acenaphthene	1.05E-09	2.30E-09	6.3E-05	22
58	Fluoranthene	7.59E-10	2.11E-09	4.5E-05	82
59	Heptachlor	6.07E-10	0.00E+00	3.6E-05	1
60	DDD [p,p']	4.75E-10	3.14E-10	2.8E-05	10
61	Fluorene	1.55E-10	1.50E-10	9.2E-06	9
62	Tritium	1.38E-10	4.07E-10	8.2E-06	43
63	Lithium	6.67E-11	8.06E-11	4.0E-06	6
64	Butyl benzyl phthalate	4.20E-11	9.41E-11	2.5E-06	11
65	Anthracene	3.90E-11	5.45E-11	2.3E-06	18
66	Acetone	3.00E-11	1.05E-10	1.8E-06	26
67	Di-n-octyl phthalate	1.95E-11	1.87E-11	1.2E-06	32
68	Methylene chloride	1.88E-11	3.72E-11	1.1E-06	27
69	Toluene	7.36E-13	2.08E-12	4.4E-08	15
70	Carbon disulfide	3.64E-13	2.39E-13	2.2E-08	2