

JUL 18 1997

SANDIA REPORT

SAND97-1150 • UC-2020

Unlimited Release

Printed May 1997

RECEIVED

JUL 29 1997

OSTI

Scoping Evaluation of the Technical Capabilities of DOE Sites for Disposal of Hazardous Metals in Mixed Low-Level Waste

Marilyn M. Gruebel, Robert D. Waters, Brenda S. Langkopf

Prepared by
Sandia National Laboratories
Albuquerque, New Mexico 87185 and Livermore, California 94550

Sandia is a multiprogram laboratory operated by Sandia Corporation, a Lockheed Martin Company, for the United States Department of Energy under Contract DE-AC04-94AL85000.

Approved for public release; distribution is unlimited.

MASTER

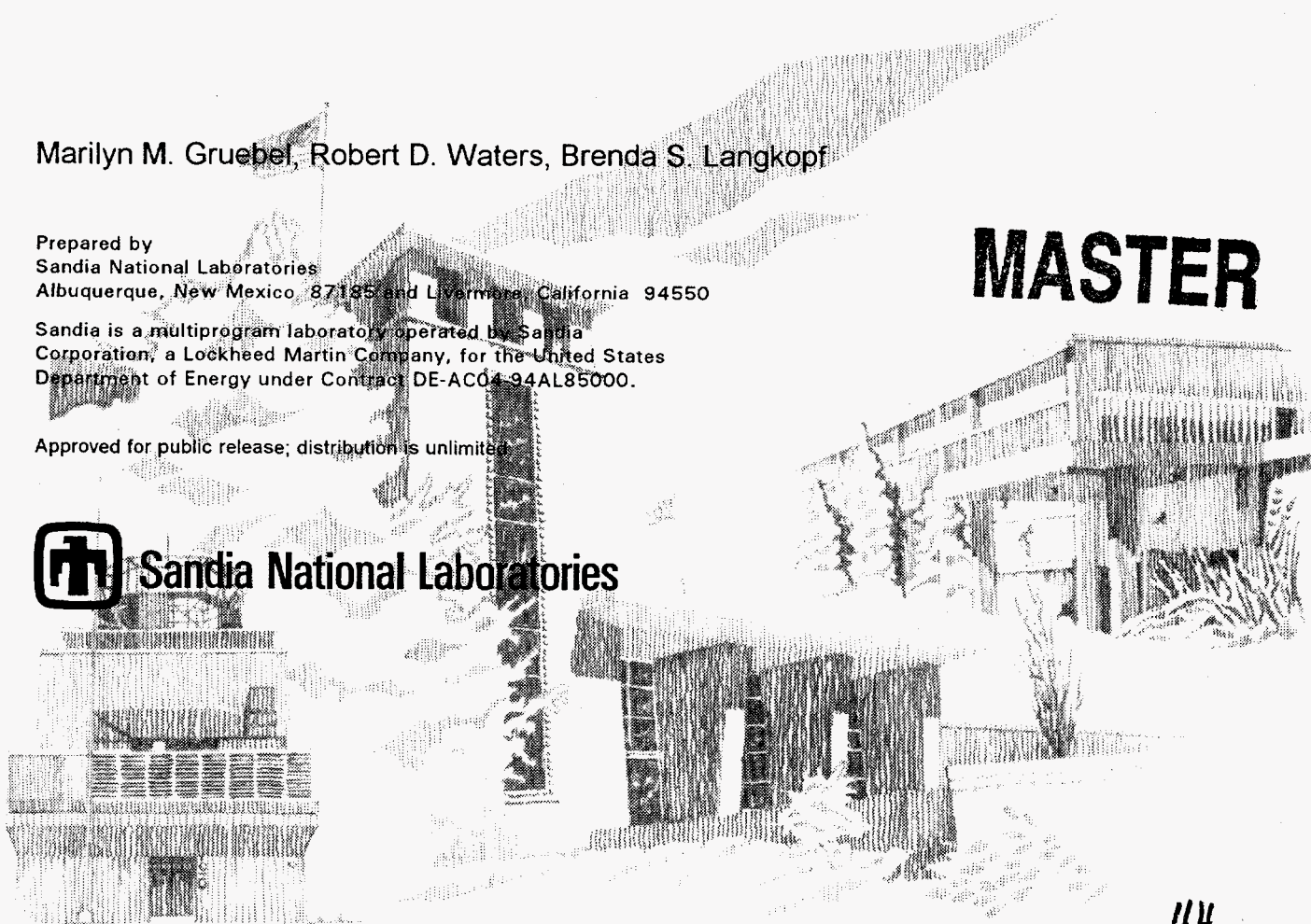

HH

Issued by Sandia National Laboratories, operated for the United States Department of Energy by Sandia Corporation.

NOTICE: This report was prepared as an account of work sponsored by an agency of the United States Government. Neither the United States Government nor any agency thereof, nor any of their employees, nor any of their contractors, subcontractors, or their employees, makes any warranty, express or implied, or assumes any legal liability or responsibility for the accuracy, completeness, or usefulness of any information, apparatus, product, or process disclosed, or represents that its use would not infringe privately owned rights. Reference herein to any specific commercial product, process, or service by trade name, trademark, manufacturer, or otherwise, does not necessarily constitute or imply its endorsement, recommendation, or favoring by the United States Government, any agency thereof, or any of their contractors or subcontractors. The views and opinions expressed herein do not necessarily state or reflect those of the United States Government, any agency thereof, or any of their contractors.

Printed in the United States of America. This report has been reproduced directly from the best available copy.

Available to DOE and DOE contractors from
Office of Scientific and Technical Information
P.O. Box 62
Oak Ridge, TN 37831

Prices available from (615) 576-8401, FTS 626-8401

Available to the public from
National Technical Information Service
U.S. Department of Commerce
5285 Port Royal Rd
Springfield, VA 22161

NTIS price codes
Printed copy: A08
Microfiche copy: A01

DISCLAIMER

This report was prepared as an account of work sponsored by an agency of the United States Government. Neither the United States Government nor any agency thereof, nor any of their employees, make any warranty, express or implied, or assumes any legal liability or responsibility for the accuracy, completeness, or usefulness of any information, apparatus, product, or process disclosed, or represents that its use would not infringe privately owned rights. Reference herein to any specific commercial product, process, or service by trade name, trademark, manufacturer, or otherwise does not necessarily constitute or imply its endorsement, recommendation, or favoring by the United States Government or any agency thereof. The views and opinions of authors expressed herein do not necessarily state or reflect those of the United States Government or any agency thereof.

DISCLAIMER

**Portions of this document may be illegible
in electronic image products. Images are
produced from the best available original
document.**

**SAND97-1150
Unlimited Release
Printed May 1997**

**Distribution
Category UC-2020**

**SCOPING EVALUATION OF THE TECHNICAL CAPABILITIES
OF DOE SITES FOR DISPOSAL OF HAZARDOUS METALS
IN MIXED LOW-LEVEL WASTE**

**Prepared for the Department of Energy (DOE)
Office of Waste Management
Federal Facility Compliance Act Disposal Workgroup**

by

**Marilyn M. Gruebel, Robert D. Waters, and Brenda S. Langkopf
Sandia National Laboratories
P. O. Box 5800
Albuquerque, New Mexico 87185-0734**

Abstract

A team of analysts designed and conducted a scoping evaluation to estimate the technical capabilities of fifteen Department of Energy sites for disposal of the hazardous metals in mixed low-level waste (i.e., waste that contains both low-level radioactive materials and hazardous constituents). Eight hazardous metals were evaluated: arsenic, barium, cadmium, chromium, lead, mercury, selenium, and silver. The analysis considered transport only through the groundwater pathway. The results are reported as site-specific estimates of "maximum concentrations of each hazardous metal in treated mixed low-level waste" that do not exceed the performance measures established for the analysis. Also reported are site-specific estimates of travel times of each hazardous metal to the point of compliance.

Members of the DOE FFCAct Disposal Workgroup

Joel Case - Chairman
Maurice Ades
Larry Bustard
Bill Gilbert
Carol Irvine
Jeff Kerridge
Martin Letourneau
Lance Mezga
Colleen O'Laughlin
Jim Orban
Roger Piscitella
Tim Sloan
Joanne Steingard
Linda Suttora
Joe Waring

DOE/Idaho
Westinghouse Savannah River Company
Sandia National Laboratories
DOE/Oak Ridge
DOE/Oakland
DOE/Rocky Flats
DOE/EM-35
Lockheed Martin Energy Systems/Oak Ridge
DOE/Nevada
DOE/Albuquerque
Idaho National Engineering Laboratory
Los Alamos National Laboratory
BDM Federal
DOE/EM-431
DOE/Richland

Contents

EXECUTIVE SUMMARY	vii
1. INTRODUCTION	1-1
1.1 PURPOSE OF REPORT.....	1-1
1.2 SUMMARY OF PLANS FOR TREATMENT OF DOE MLLW	1-2
1.3 SELECTION OF SITES FOR EVALUATION.....	1-3
1.4 LIMITATIONS OF THE ANALYSIS	1-4
2. ASSUMPTIONS AND APPROACH USED IN THE SCOPING EVALUATION	2-1
2.1 PERFORMANCE MEASURES	2-1
2.1.1 Performance Boundary.....	2-2
2.1.2 Concentrations of Hazardous Constituents in Groundwater	2-2
2.1.3 Time Period of the Analysis	2-3
2.2 SOURCE TERM.....	2-3
2.2.1 Waste Form	2-3
2.2.2 Disposal-Facility Design	2-4
2.3 WATER PATHWAY TRANSPORT	2-7
2.3.1 Source CRF	2-9
2.3.2 Water Pathway Transport CRF	2-11
2.3.3 Solubilities of Hazardous Metals.....	2-13
2.3.4 Estimation of Travel Time.....	2-14
3. EFFECTS OF CONCEPTUAL MODEL ASSUMPTIONS AND PARAMETER SENSITIVITY.....	3-1
3.1 MAJOR ASSUMPTIONS USED IN CONCEPTUAL MODELS	3-1
3.1.1 Applicable Regulations	3-1
3.1.2 Waste Form and Performance	3-1
3.1.3 Type of Disposal Facility	3-1
3.1.4 Performance of Engineered Barriers	3-2
3.1.5 Solubility Constraints	3-2
3.1.6 Transport Retardation Model and Sorption Effects.....	3-3
3.1.7 Continuous Source	3-4
3.1.8 Treatment of Fracture Flow.....	3-5
3.1.9 Regional Recharge	3-5
3.2 PARAMETER SENSITIVITY	3-5
4. RESULTS AND CONCLUSIONS	4-1
4.1 SUMMARY OF NATURAL SITE CHARACTERISTICS.....	4-1
4.2 SUMMARY OF RESULTS.....	4-5
4.2.1 Performance of Sites	4-5
4.2.2 Fate of Hazardous Metals.....	4-7
4.3 CONCLUSIONS.....	4-8
5. REFERENCES	5-1
Appendix A: Hazardous Constituents in Treated Mixed Low-Level Waste	A-1
Appendix B: Site Evaluations.....	B-1

Figures

Figure 1-1. Sites considered in the scoping evaluation for disposal of hazardous metals in treated MLLW.....	1-4
Figure 2-1. Schematic representation of a generic trench.....	2-5
Figure 2-2. Assumed performance of engineered barriers.....	2-6
Figure 2-3. Generic conceptual model for the water pathway.....	2-11
Figure 4-1. Selected characteristics of the 15 sites.....	4-3
Figure 4-2. Conservative estimates of vertical and lateral components of water travel times (y) based on this scoping evaluation of hazardous metals.....	4-4

Tables

Table 1. Sites Considered in the Scoping Evaluation for Disposal of Hazardous Metals in Treated MLLW.....	vii
Table 1-1. Proposed Treatment Options for MLLW	1-3
Table 2-1. Maximum Concentrations of Hazardous Metals in Groundwater Used as Performance Measures.....	2-3
Table 2-2. Summary of Grout and Facility Parameters That Affect the Source Term CRF (CRF_{Source}).....	2-10
Table 2-3. Values for K_d^G for Hazardous Metals in Grout Used in the Scoping Evaluation and Resulting Concentration Reduction Factors for the Source (CRF_{Source}).....	2-11
Table 2-4. Solubility Values for Possible Hazardous Metal Compounds in a MLLW Disposal Facility and for the Associated Metals	2-14
Table 2-5. Generic Soil K_d Values Used in the Scoping Analysis.....	2-16
Table 3-1. Comparison of Maximum Soil Concentrations Used in the Scoping Evaluation with Maximum Sorption Capacities Reported in the Literature for RCRA Hazardous Metals.....	3-3
Table 4-1. Summary of Maximum Hazardous Metals Concentrations in Treated MLLW	4-6

Nomenclature

ANLE	Argonne National Laboratory-East
CRF	concentration reduction factor
DAF	dilution attenuation factor
DOE	U.S. Department of Energy
DWG	Disposal Workgroup
EPA	U.S. Environmental Protection Agency
FEMP	Fernald Environmental Management Project
FFCAct	Federal Facility Compliance Act
INEL	Idaho National Engineering Laboratory
LANL	Los Alamos National Laboratory
LDR	land disposal restrictions
LLNL	Lawrence Livermore National Laboratory
LLW	low-level waste
MLLW	mixed low-level waste
NTS	Nevada Test Site
ORR	Oak Ridge Reservation
PATT	Performance Assessment Task Team
PGDP	Paducah Gaseous Diffusion Plant
PORTS	Portsmouth Gaseous Diffusion Plant
RCRA	Resource Conservation and Recovery Act
RFETS	Rocky Flats Environmental Technology Site
SNL	Sandia National Laboratories
SRS	Savannah River Site
STP	site treatment plan
WVDP	West Valley Demonstration Project

EXECUTIVE SUMMARY

The Federal Facility Compliance Act of 1992 requires the U.S. Department of Energy (DOE) to work with its regulators and with members of the public to establish plans for the treatment of DOE's mixed low-level waste (MLLW). The act does not specifically address disposal of treated MLLW. However, both DOE and the states that host DOE facilities recognize that disposal is an integral part of treatment issues and maintain an open dialogue on issues pertaining to the disposal of treated MLLW.

A performance evaluation was completed in early 1996 that quantified and compared the potential technical capabilities of 15 DOE sites for disposal of the radionuclides in treated MLLW. During discussions about the focus of the performance evaluation, the affected states requested additional analyses, similar to the water pathway analysis conducted in the performance evaluation of radionuclides, that would address disposal of the hazardous component of (i.e., the hazardous metals in) treated MLLW.

The purpose of this report is to provide consistent scoping-level analyses of the performance of a hypothetical MLLW disposal facility at fifteen DOE sites (Table 1) for selected hazardous metals expected to be in treated DOE MLLW. The primary results of the analyses are site-specific estimates of "maximum concentrations of hazardous metals in treated MLLW" that do not exceed the performance measures established for this analysis. As was the case with the performance evaluation for radionuclides in treated MLLW, this scoping evaluation only considered the technical capabilities of the sites for waste disposal: No ethical, social, or policy considerations relevant to siting MLLW disposal facilities are discussed in this report.

Table 1. Sites Considered in the Scoping Evaluation for Disposal of Hazardous Metals in Treated MLLW

Lawrence Livermore National Laboratory (LLNL), California
Rocky Flats Environmental Technology Site (RFETS), Colorado
Idaho National Engineering Laboratory (INEL), Idaho
Argonne National Laboratory -East (ANLE), Illinois
Paducah Gaseous Diffusion Plant (PGDP), Kentucky
Nevada Test Site (NTS), Nevada
Los Alamos National Laboratory (LANL), New Mexico
Sandia National Laboratories (SNL), New Mexico
West Valley Demonstration Project (WVDP), New York
Fernald Environmental Management Project (FEMP), Ohio
Portsmouth Gaseous Diffusion Plant (PORTS), Ohio
Savannah River Site (SRS), South Carolina
Oak Ridge Reservation (ORR), Tennessee
Pantex Plant (Pantex), Texas
Hanford Site (Hanford), Washington

Current federal regulations for disposal of hazardous waste do not require the specific types of analyses described in this report. As indicated by the Resource Conservation and Recovery Act (RCRA), protection of the environment is implicitly assumed to be attained through a combination of prescriptive standards for treatment of hazardous waste and design of disposal facilities to contain this waste. States that have been delegated the authority to enforce the hazardous waste regulations under RCRA may, at their discretion, enact requirements that exceed those described in the federal regulations. However, the experience of the DOE sites that have permits for hazardous waste disposal facilities indicates that no additional long-term performance requirements for these types of facilities have been imposed by the states.

Eight hazardous metals were evaluated: arsenic, barium, cadmium, chromium, lead, mercury, selenium, and silver. Only hazardous metals were evaluated for three reasons: the amounts and concentrations of hazardous organic constituents in treated MLLW are expected to be small; many of the hazardous organic constituents are expected to be destroyed during treatment; and site-specific data related to transport of hazardous organic constituents through the environment are not readily available.

Several generic assumptions were made that allowed consistent analysis across the fifteen sites:

- The point of compliance (performance boundary) was 100 m from the edge of the disposal facility.
- The performance measures were the maximum concentrations of hazardous metals for groundwater protection identified in Table 1 of 40 CFR 264.94.
- No specific time period of analysis was used. Instead, the estimated travel times to the performance boundary of the maximum concentrations of the hazardous metals in groundwater are reported.
- The treated MLLW was stabilized with grout.
- The disposal facility design used in the analysis was a trench that complied with RCRA regulations.
- Engineered barriers remained intact for 100 years after closure of the disposal facility.

A generic conceptual model was used to describe transport in the water pathway. Values provided by each site were used for the hydrogeologic parameters, and the model was modified as necessary to reflect site-specific conditions.

The results of the scoping evaluation are reported as maximum concentrations of hazardous metals in treated MLLW in a disposal facility. The solubilities of the evaluated metals were used as potential limits on the maximum concentrations of hazardous metals in the leachate exiting the disposal facility and thus on the maximum concentrations of hazardous metals in treated MLLW: if the calculated maximum concentration of a hazardous metal in the leachate (i.e., in the solution containing hazardous metals dissolved in water) exiting the disposal facility was greater than the solubility of the metal, then the maximum concentration of that metal in disposed waste at that site was considered to have "no limit."

Also reported as results of the scoping evaluation are estimates of travel times of hazardous metals to the performance boundary. These estimates were influenced by metal/soil distribution coefficients (i.e., by K_d values). Travel times were calculated as the sum of the retarded contaminant travel times in the vadose (unsaturated) and saturated zones. While site-specific analyses such as performance assessments for radioactive waste disposal attempt to be conservative representations of actual site behavior, the model used in this scoping evaluation likely provided even more conservative results (i.e., lower maximum concentrations of hazardous metals allowed in treated MLLW and shorter travel times to the performance boundary) because of the simple transport assumptions that were used.

To facilitate observations about the results of the scoping evaluation, the fifteen sites considered in this scoping evaluation were classified as "arid" or "humid" based on their climatological characteristics. The sites classified as arid are LLNL, Hanford, NTS, INEL, RFETS, SNL, LANL, and Pantex. The sites classified as humid are ANLE, PGDP, FEMP, PORTS, ORR, SRS, and WVDP. Based on the results of this scoping evaluation, the following general conclusions can be made about disposal of hazardous metals in treated MLLW:

- All fifteen DOE sites considered in this analysis have the technical capability for disposal of some hazardous metals in treated MLLW. However, the technical capabilities for disposal of hazardous metals differ somewhat among the sites. Some sites have an estimated maximum concentration of a particular hazardous metal that is one to two orders of magnitude greater than that of another site.
- In general, travel times of the hazardous metals to the performance boundary were greater than 10,000 years at the arid sites and between 1000 and 10,000 years at the humid sites.
- Of the eight hazardous metals considered in the analysis, barium and lead tended to be relatively immobile at both the arid and humid sites; selenium tended to be the most mobile.
- The modeling in this analysis is believed to be conservative (i.e., provide lower maximum concentrations of hazardous metals allowed in treated MLLW and shorter travel times to the performance boundary) compared to more rigorous analyses. Therefore, in cases where maximum concentrations of hazardous metals in treated MLLW are high or unlimited, a more rigorous analysis would be of little additional benefit, provided performance measures similar to those assumed in this analysis were applied to future disposal facilities. Conversely, in cases where the maximum concentrations of hazardous metals in treated MLLW are relatively low (e.g., at ORR), more refined analyses that account for additional site-specific factors for transport of hazardous metals in water could result in higher maximum concentrations. Additionally, as site characterization continues and more information becomes available, exposure pathways other than those evaluated here may be identified that could also change the maximum concentrations of hazardous metals in treated MLLW.

Intentionally left blank

1. INTRODUCTION

The Federal Facility Compliance Act (FFCA) of 1992 (FFCA, 1992) requires the U.S. Department of Energy (DOE) to work with its regulators and with members of the public to establish plans for the treatment of DOE's mixed low-level waste (MLLW). Along with other radioactive and hazardous waste, wastes that are now considered MLLW have been generated for more than 50 years through DOE activities related to the production of materials for nuclear weapons and research with nuclear materials; however, the regulatory recognition of MLLW originated in the Resource Conservation and Recovery Act (RCRA) of 1976 (RCRA, 1976). Although the FFCA does not specifically address disposal of treated MLLW, both DOE and the states that host DOE facilities (the States) recognize that disposal issues are an integral part of treatment discussions.

The DOE established the FFCA Disposal Workgroup (DWG) in June 1993 to work with the States in defining and developing a process for evaluating disposal options for treated MLLW. The focus of the DWG process and of discussions on disposal with the States has been to identify, from among the sites currently storing or expected to generate MLLW, those that are suitable for further evaluation in terms of their disposal capabilities.

A three-volume report prepared by the DWG describes a performance evaluation that quantified and compared the potential technical capabilities of 15 DOE sites for disposal of stabilized residuals resulting from the treatment of MLLW (DOE, 1996). That report discusses the methodology, describes the evaluated sites, and provides estimates of permissible concentrations of radionuclides in treated MLLW for disposal at each site. During discussions about the focus of the performance evaluation, the States requested additional analyses, similar to the water pathway analysis conducted in the performance evaluation for radionuclides, that would address disposal of the hazardous component of MLLW. This report encompasses the analysis of some of the hazardous metals expected to be present in treated MLLW.

1.1 PURPOSE OF REPORT

The purpose of this report is to provide consistent scoping-level analyses of the performance of hypothetical DOE disposal facilities for selected hazardous metals expected to be in DOE MLLW after it is treated. The primary results of the analyses are site-specific estimates of "maximum concentrations of each evaluated hazardous metal in treated MLLW" that do not exceed the performance measures established for the analysis. These estimates are based on assumptions about the concentration attenuation provided by the waste form, disposal facility, and water pathway.

An analysis of the hazardous organic constituents in treated MLLW was not performed because (1) the amounts and concentrations of these constituents in treated MLLW are expected to be small, (2) future treatment processes may destroy or remove most of the hazardous organic constituents from MLLW, and (3) site-specific data related to transport of hazardous organic

constituents are not readily available. A summary of the types of hazardous constituents that may be expected to be present in treated MLLW is provided in Appendix A.

The technical analyses described in this report were based on assumptions pertaining to (1) performance measures, (2) long-term performance of the waste form and hypothetical disposal facility, and (3) transport of the hazardous constituents through the water pathway. The assumptions made about each of these components of the analysis are presented in Chapter 2. No ethical, social, or policy considerations relevant to siting MLLW disposal facilities are discussed in this report.

Current federal regulations for disposal of hazardous waste do not specifically require the types of analyses described in this report. Protection of the environment is implicitly assumed to be attained through a combination of prescriptive standards for treatment of hazardous waste and design of disposal facilities to contain this waste. States that have been delegated the authority to enforce the hazardous waste regulations under RCRA may, at their discretion, enact requirements that exceed those described in the federal regulations. However, the experiences of the DOE sites permitting hazardous waste disposal facilities have not revealed that long-term performance calculations such as those contained in this report have been required. At sites where disposal of treated MLLW is planned, the specific requirements of state and federal regulations are expected to be addressed through site-specific performance assessments and other analyses required to demonstrate compliance with applicable regulations.

1.2 SUMMARY OF PLANS FOR TREATMENT OF DOE MLLW

The DOE currently generates, stores, or expects to generate (over the next five years) about 130,000 m³ of MLLW at 39 sites in 19 states (Waters et al., 1997) as identified in DOE's database for its 1995 Mixed Waste Inventory Report. Because MLLW has a hazardous component, it must be treated to comply with the land disposal restrictions of RCRA. However, there is either insufficient capacity to treat all the waste or a lack of available technologies to treat all the waste within the one-year storage time allowed by RCRA 3004(j). The FFCAct requires the Secretary of Energy to develop and submit site treatment plans (STPs) for the development of capacity for treating mixed waste for each facility where the DOE stores or generates this waste. These plans identify how the DOE will provide necessary treatment capacity for mixed waste, including schedules for bringing new treatment facilities into operation. In collaboration with the States and the National Governors' Association, the DOE has developed the required treatment plans at 35 DOE sites. Most of these STPs have since resulted in consent or compliance orders with the appropriate state or federal regulating body.

A summary of the proposed treatment options for MLLW and the associated volume of waste to be treated by each treatment type is provided in Table 1-1. All treatment methods will result in solid waste forms for disposal.

Table 1-1. Proposed Treatment Options for MLLW (Waters et al., 1996, Table 1-2)

WASTE TYPE	VOLUME OF WASTE (m ³) ^a	% OF TOTAL VOLUME
Alkali Metals Treatment	690	0.
Amalgamation	20	<0.1
Deactivation	810	0.4
Inorganic Debris Treatment	8,600	4.3
Mercury Separation	1,170	0.6
Neutralization/Non-Aqueous	10	<0.1
None/Meets LDR	31,660	15.7
Organic Destruction	24,280	12.1
Pre- or Post-Treatment	26,620	13.2
Soil Washing	6,590	3.3
Stabilization	57,270	28.5
To Be Determined	29,250	14.5
Wastewater Treatment	4,430	2.2
Waste Isolation Pilot Plant	9,830	4.9
TOTAL	201,230	100.0^b

a Includes both waste with and without identified treatment options and waste stream volumes proposed for treatment by multiple systems (i.e., treatment train volumes). Consideration of multiple treatment systems causes total volume shown in Table 1-1 to be greater than the actual total volume.

b Does not add to 100.0% because of rounding

1.3 SELECTION OF SITES FOR EVALUATION

The sites selected for evaluation in this analysis are the same as those sites evaluated in the performance evaluation for radionuclides (Figure 1-1). These sites were selected from an initial universe of 49 DOE sites that either currently stored or were expected to generate MLLW over the next five years.* The 49 sites were screened to 26 sites by (1) grouping sites in geographic proximity and (2) evaluating the sites using three criteria with regulatory or operational bases. The 26 remaining sites were further screened to 15 sites after evaluating factors related to technical, potential receptor, and practical considerations that would make hosting a MLLW disposal facility at a particular site extremely difficult. The DOE and States reached agreement on the list of 15 sites to consider for further evaluation at a joint meeting in July 1994. Additional detail on these screening analyses is provided in Chapter 2 of Waters et al. (1996).

* Information compiled since 1993 indicates that the DOE currently generates, stores, or expects to generate (over the next five years) MLLW at 39 sites.

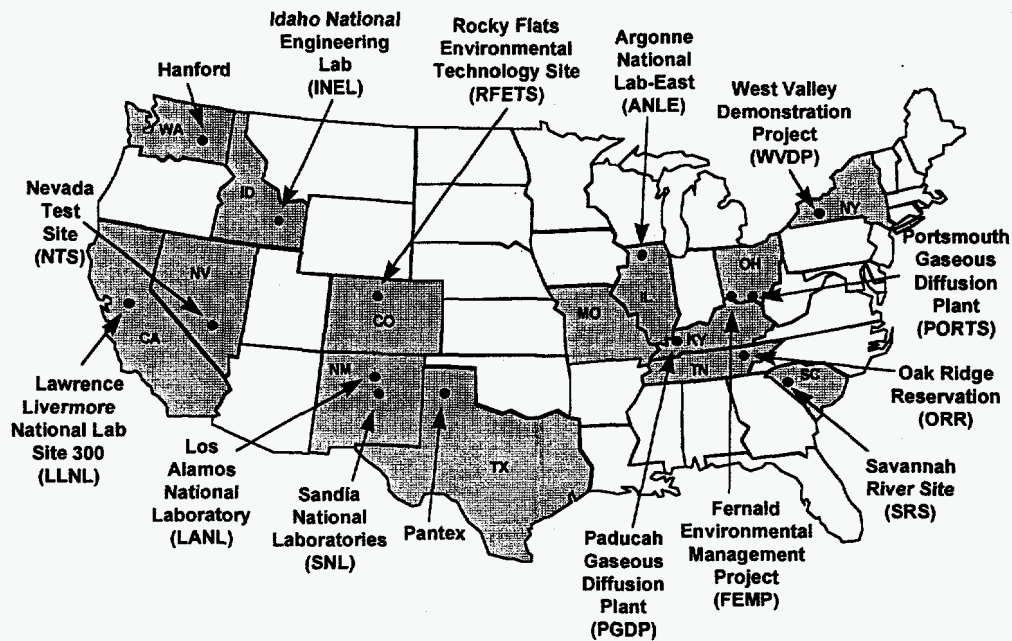

Figure 1-1. Sites considered in the scoping evaluation for disposal of hazardous metals in treated MLLW.

1.4 LIMITATIONS OF THE ANALYSIS

The determination of the maximum concentrations of hazardous metals in MLLW is a scoping-level analysis that considered only water pathway transport. The concentration limits were determined by using a set of modeling assumptions that included sufficient detail to capture major site-specific characteristics but were general enough for consistent application at all sites. As site characterization continues and more information becomes available, exposure pathways other than water might be identified that could also change the maximum concentrations of hazardous metals in treated MLLW.

In addition, there are no federally regulated compliance measures for hazardous metals. The DOE Performance Assessment Task Team (PATT) recommended some guidelines related to conducting performance assessments that were used to determine performance measures for this analysis. The U. S. Environmental Protection Agency (EPA) regional administrator will specify the concentration limits in groundwater for hazardous constituents identified when permitting a hazardous waste disposal facility.

Neither the existing levels of contamination that may exist at the 15 sites nor the effects of overlapping plumes from nearby disposal facilities or accidental releases were considered in this scoping analysis.

2. ASSUMPTIONS AND APPROACH USED IN THE SCOPING EVALUATION

The analysis described in this report was a scoping evaluation for estimating the technical capabilities of 15 DOE sites for disposal of hazardous metals in treated MLLW. The principal goal of the scoping evaluation was to estimate, for stabilized residuals resulting from the treatment of MLLW, the maximum concentrations of hazardous metals in treated MLLW for disposal at each site that do not exceed the selected performance measures at the performance boundary. These maximum concentrations of hazardous metals were based solely on performance of the disposal facility and surrounding hydrogeological environment and did not take into account any operational waste acceptance criteria that might have been developed for a particular site.

The elements of the assumptions and approach used in the scoping evaluation are described in this chapter. Many of these assumptions are similar to those used in the performance evaluation for radionuclides in treated MLLW (Waters et al., 1996). Three major components constitute the assumptions and approach of the scoping evaluation: (1) performance measures; (2) source term; and (3) transport of contaminants through the water pathway. These components are discussed in Sections 2.1 through 2.3.

2.1 PERFORMANCE MEASURES

The selection of measures for analyzing the performance of disposal facilities containing hazardous metals is hampered by the lack of both regulatory drivers and precedent. The hazardous metals evaluated in this analysis were assumed to be contained in treated MLLW, and the performance objectives in DOE Order 5820.2A (DOE, 1988) for evaluating performance of disposal facilities containing low-level radioactive waste were first considered as the basis for the performance measures. Two of the four objectives are applicable to the performance of disposal facilities containing hazardous metals as well as to those containing radioactive constituents. They are: (1) "protect public health and safety in accordance with standards specified in applicable Environmental Health orders and other DOE orders," and (2) "protect ground water resources, consistent with Federal, State, and local requirements." The other two objectives are applicable only to radioactive constituents.

Because the DOE order is silent or not specific on many other issues related to performance of radioactive waste disposal facilities, the DOE formed the PATT to recommend specific guidelines related to conducting performance assessments. The PATT, which is comprised of DOE contractor specialists in performance assessment, has issued several recommendations for implementing DOE Order 5820.2A (Wood et al., 1994a). Some of these recommendations are applicable to this performance analysis of disposal facilities for treated MLLW containing hazardous metals.

Guidelines related to three additional performance measures are necessary for this analysis: the location of a point of compliance (performance boundary), the maximum

concentrations of hazardous metals for protection of groundwater at or beyond the performance boundary, and the time period of the analysis.

2.1.1 Performance Boundary

According to the regulations enforcing RCRA, the point of compliance for measuring concentrations of hazardous contaminants in groundwater released from a hazardous waste disposal facility is determined by the regional administrator (40 CFR Part 264.95) and may be site specific. Based on a recommendation of the PATT, the performance boundary (i.e., the point of compliance) was assumed to be located at 100 m from the edge of the disposal facility. The 100-m performance boundary was used in this analysis as the location for applying the performance measures for the maximum concentrations of hazardous metals in groundwater from which the maximum concentrations of hazardous metals in treated MLLW were estimated. The 100-m performance boundary has been used in the performance evaluation for radionuclides in MLLW (Waters et al., 1996) and in site-specific performance assessments for disposal of low-level waste.

2.1.2 Concentrations of Hazardous Constituents in Groundwater

To protect groundwater resources, performance assessments for low-level radioactive waste are based on a specified performance objective, often interpreted as a limit on effective dose equivalent of 4 mrem (0.04 mSv) per year in the drinking water pathway for all radionuclides. Because a performance assessment for hazardous waste disposal facilities is currently not required, specific performance objectives do not exist. However, in a permit for a hazardous waste disposal facility, the EPA regional administrator will specify the concentration limits in groundwater for hazardous constituents identified in the permit.

In the scoping evaluation described in this report, the maximum concentrations of metals for groundwater protection identified in Table 1 of 40 CFR Part 264.94 (Table 2-1) were used as performance measures. The metal concentrations listed in this table are the same as those listed in 40 CFR Part 265 Appendix III as the "EPA interim primary drinking water standards." These 8 hazardous metals were chosen because they were expected to be present in treated MLLW, had an identified performance measure, and represented a range of the transport characteristics for all the hazardous metals expected to be present in DOE MLLW. For these reasons, the 8 hazardous metals listed in Table 2-1 were considered representative of other hazardous metals expected to be in treated MLLW.

Hazardous organic constituents of MLLW were not analyzed, although according to current plans for waste treatment some of these constituents are expected to be present in treated MLLW (see Appendix A). The amounts and concentrations of hazardous organic constituents in treated MLLW are expected to be small, although this assumption cannot be specifically supported due to insufficient data. Also, data for site-specific hydrologic and transport-related parameters required for the analysis of hazardous organic constituents were not readily available. Because an evaluation of the long-term performance of disposal facilities for hazardous waste is not currently required, this situation is expected to continue. Additionally, future revisions to site treatment plans may provide for treatment that will either remove or destroy the hazardous organic constituents that will remain after treatment using current plans.

Table 2-1. Maximum Concentrations of Hazardous Metals in Groundwater Used as Performance Measures (based on 40 CFR Part 264.94)

Constituent	Maximum Concentration (mg/L)
Arsenic (As)	0.05
Barium (Ba)	1.0
Cadmium (Cd)	0.01
Chromium (Cr)	0.05
Lead (Pb)	0.05
Mercury (Hg)	0.002
Selenium (Se)	0.01
Silver (Ag)	0.05

2.1.3 Time Period of the Analysis

An additional recommendation of the PATT regarding disposal of low-level radioactive waste was the consideration of 10,000 years after disposal as the time period of analysis. For radionuclides whose peak release occurs at the performance boundary beyond 10,000 years after disposal, the PATT recommended that the analysis be extended to the time of peak release. This analysis would be more a mathematical exercise than a compliance prediction because major climatic, geologic, and anthropological changes may occur at later times (Wood et al., 1994a, p. 35). Although this recommendation was incorporated into the performance evaluation for radionuclides in MLLW (DOE, 1996), it was not incorporated into this scoping evaluation of hazardous metals.

The RCRA regulations do not specifically require a long-term performance assessment of disposal facilities for hazardous waste (the required post-closure monitoring period is 30 y). Thus, a performance objective for the time period of the analysis has never been defined. Also, because hazardous metals do not decay with time, a time-associated performance measure does not hold the same value as it does for radionuclides. In this scoping evaluation, no specific time period of analysis was used. Instead, the estimated travel time of the maximum concentration of the hazardous metals to the performance boundary is reported.

2.2 SOURCE TERM

Two subcomponents are important in determining the release of contaminants from the source in the disposal facility: physical and chemical characteristics of the waste form and design of the disposal facility. These two subcomponents are described below.

2.2.1 Waste Form

Although almost any combination of waste matrix and contaminant can be found within the DOE waste inventory, some combinations are more common. The major categories of waste

matrices that are known or are expected to contain hazardous metals are aqueous solutions and inorganic solids (i.e., mainly sludges, filter cakes, and residuals) (DOE, 1993). These waste streams form a significant portion of the DOE MLLW inventory. Hazardous metals also occur in cemented solids (including liquids and sludges that have been solidified/stabilized with Portland cement but do not meet land disposal restrictions [LDR] treatment standards), soils, debris, organic solutions/sludges, and other MLLW types found in the DOE system.

The STPs developed for each DOE site specify the preferred treatment for each mixed waste stream. Because final waste forms are not indicated in many site treatment plans, assumptions were made in the scoping evaluation about the waste form. In these analyses, the waste form was assumed to be grouted treatment residuals. Grout, consisting primarily of hydrated Portland cement and fly ash, is often used to stabilize waste containing hazardous metals or to stabilize residuals resulting from thermal treatment. Grout is considered the primary waste-form stabilizer in three low-level waste performance assessments: Oak Ridge Solid Waste Storage Area 6 (SWSA 6) (ORNL, 1994); Hanford tanks (Kincaid et al., 1993); and Savannah River Z-Area (MMES et al., 1992). Although other waste forms may be proposed in the site treatment plans, grouted treatment residuals are common. Additional information and assumptions used to evaluate the behavior of a grouted waste form are presented in Section 2.3.1.

To date, two types of MLLW streams containing hazardous metals—lead solids and elemental mercury—have technology-based LDR standards as specified in the RCRA regulations (40 CFR Part 268.40). All MLLW containing bulk lead must be macroencapsulated. Because elemental mercury is easily volatilized, it cannot be immobilized by the same technologies as other hazardous metals and must be removed and treated separately. In order to meet RCRA regulations, radioactively contaminated elemental mercury must be amalgamated (made into a stable solid form) prior to disposal. For this reason, DOE has subdivided metal-bearing waste into two groups based on the presence or absence of mercury (DOE, 1993).

The results of the analyses in this report are not applicable to bulk lead and elemental mercury because of the specific treatment technologies that are required by RCRA for these wastes. However, the results in this report are applicable to waste that contains trace amounts of lead and mercury and that is stabilized in grout.

2.2.2 Disposal-Facility Design

A generic facility design was used in the scoping evaluation that allowed common assumptions for consistent comparison of the disposal capabilities of the 15 sites. A RCRA-compliant trench (Figure 2-1) was the disposal facility used in this analysis, although actual facility designs for disposal of MLLW may be different. The RCRA-compliant trench was chosen because it represents a disposal facility with minimal engineered barriers.

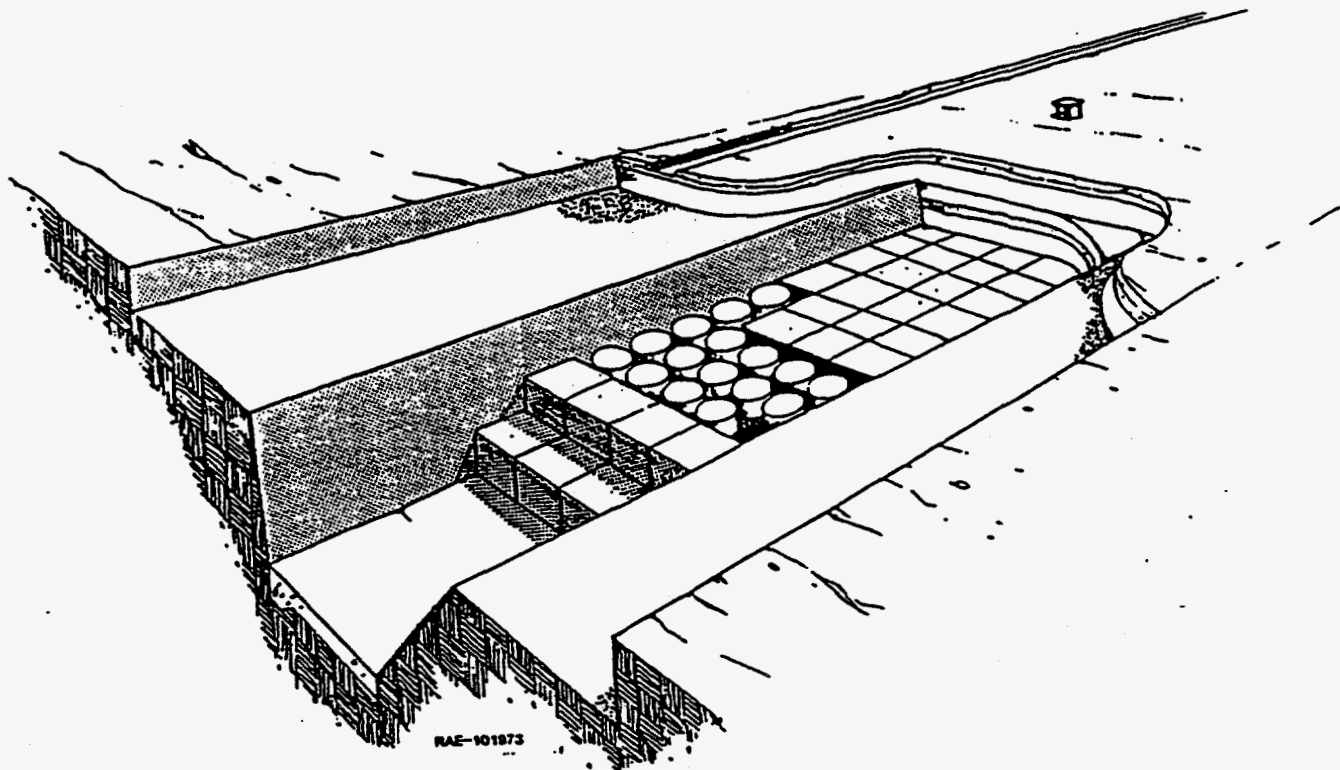

Figure 2-1. Schematic representation of a generic trench.

At sites in the humid region of the country, disposal facilities for low-level waste generally contain more engineered features (e.g., tumulus facilities are used at ORR and vault facilities are used at SRS). While the additional engineered features of these facilities minimize infiltration of water and prevent mobilization of wastes due to contact with water, the duration of the performance of these features is not known, and assumptions must be made in the performance assessments for these facilities. An assumption commonly made is that, regardless of the assumed duration of performance, the facility performance eventually is similar to that of the surrounding geologic environment. Therefore, because all facility types (e.g., trench, tumulus, and vault) are assumed to eventually perform similarly after failure, one disposal design was used to represent all facilities for contaminants such as hazardous metals that do not degrade or decay.

At a few sites (i.e., PGDP, PORTS, WVDP, and ORR), the standard trench design may not be the most feasible because of the shallow depth to groundwater; these exceptions are noted in the individual site-evaluation sections in Appendix B. For most of these sites, the disposal facility was assumed to have the characteristics of a RCRA-compliant trench but was located nearer to or on the ground surface to provide some distance between the bottom of the disposal facility and the groundwater.

At all sites, the trench facility was assumed to be square with a plan area of 2500 m², although trench facilities are generally more rectangular than square. Because the length of the disposal facility parallel to the flow of groundwater is usually the most important dimension for evaluating protection of groundwater, the orientation of a rectangular disposal facility must be specified to determine the expected performance of the facility. Using a square-shaped facility does not require orienting the trench with respect to the direction of groundwater flow; the square shape tends to provide “average” results for rectangular facilities of unknown orientation. A facility of 2500 m² was chosen because it was the largest area that could be located on all of the 15 sites being evaluated. Grouted waste packages were assumed to be placed directly into the trench and then backfilled with natural soils. The waste was assumed to account for 2/3 of the volume of the disposal facility, with the remaining 1/3 of the disposal facility assumed to be non-waste packaging and backfill. No credit was taken for any non-waste packaging or backfill.

Compliance with RCRA was assumed by designing engineered barriers for the disposal facility in the manner prescribed in the regulations (40 CFR Part 264, Subpart N, and 40 CFR Part 265, Subpart N). The major RCRA requirements for disposal facility design are a cover system with low hydraulic conductivity and a leachate collection system and liner. The behavior of these engineered components was assumed to be the same for all 15 sites, regardless of site-specific climate and other mechanisms that may promote or slow their degradation.

The liner and leachate collection system were assumed to function as designed for 30 years, the required minimum period of active monitoring (10 CFR Part 264.117). For the first 30 years following closure, the leachate collection system was assumed to collect all leachate from the facility so that no releases from the site occurred during that time (Figure 2-2).

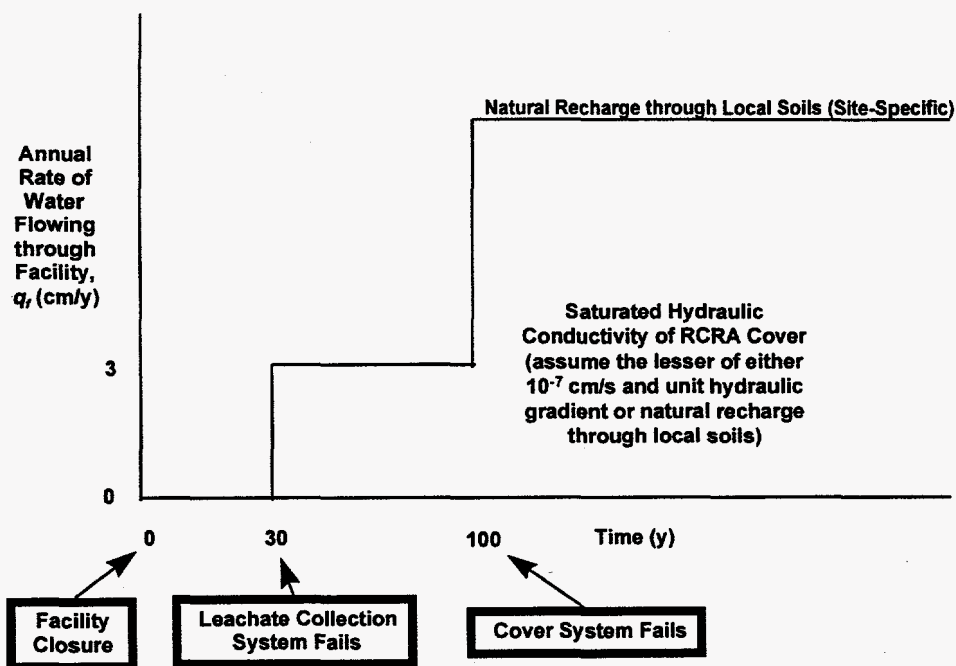

Figure 2-2. Assumed performance of engineered barriers.

The liner and leachate collection system were assumed to fail abruptly at 30 years after closure. At that time, releases of hazardous metals from the facility were possible by movement of water through the RCRA cover into the facility. The rate of water movement through the cover into the facility was calculated based on the lesser of either a unit hydraulic gradient and a saturated hydraulic conductivity of 1×10^{-7} cm/s (0.03 m/y) (as required by RCRA for the cover system in 40 CFR Parts 264.301 and 264.310), or the site-specific value for natural recharge through local soils.

Active institutional controls were assumed to last for 100 years, a standard period of time used in performance assessments for the duration of such controls (ORNL, 1994; Kincaid et al., 1993; MMES et al., 1992). After this time the facility cover was assumed to receive no maintenance, so the rate of water movement through the disposal facility became the same as the average annual recharge through local soils. In other words, after 100 years, the RCRA cover system and the liner were assumed to have degraded in such a way that they were indistinguishable from the local soils.

The location of the hypothetical disposal facility was based on input from site technical personnel. For sites with MLLW disposal plans, the planned location of the facility was used in the scoping evaluation. For sites with no existing low-level waste (LLW) or planned MLLW disposal facilities, considerations such as current operations, hydrogeology, and future land use were used in designating a location for a hypothetical disposal facility. Larger sites with relatively uniform hydrogeologic conditions had many possible site locations. For these sites, an approximate location was chosen for the disposal facility.

2.3 WATER PATHWAY TRANSPORT

The transport component of the scoping evaluation addressed the migration and attenuation of hazardous metals through the water pathway from the time they were released from the disposal facility until they reached the performance boundary. The maximum allowable concentration in water at the performance boundary was defined for each evaluated hazardous metal (shown in Table 2-1). Using these concentrations as performance measures, maximum concentrations of hazardous metals in treated MLLW in the disposal facility were estimated by accounting for attenuation at each site due to release from the waste form and transport through the water pathway to the performance boundary.

Concentration reduction factors (CRFs) were used to represent the attenuation that occurred between the waste in the disposal facility and the performance boundary. The CRF approach was used so that intermediate results could be displayed in a transparent manner that allowed comparison of the effects of the disposal facility and the site on overall performance. This approach also allowed comparison of results from different sites. Two CRFs were used in analyzing the transport of hazardous metals—one for the source and the other for water pathway transport. The CRF for the source accounted for the attenuation between the waste and the leachate exiting the bottom of the disposal facility. Dilution of leachate with groundwater was the only CRF mechanism used in the water pathway transport of contaminants.

The scoping evaluation for each site began with a generic conceptual model that was modified based on site-specific environmental characteristics. Results are reported as maximum concentrations of hazardous metals in treated MLLW in the disposal facility and estimated travel times of the hazardous metals in the water pathway to the performance boundary. The maximum concentrations in treated MLLW in the disposal facility based on transport through the water pathway were calculated using

$$C_{Waste} = C_{Water} \times CRF_{Source} \times CRF_{Water} \times \frac{1}{\rho_b^*} \quad (2-1)$$

where

C_{Waste} is the maximum concentration of a hazardous metal in treated MLLW in the disposal facility corresponding to its maximum concentration in water at the performance boundary (mg/kg);

C_{Water} is the maximum allowable concentration in water at the performance boundary for a specific hazardous metal (mg/L);

CRF_{Source} is the concentration reduction factor for the source (dimensionless);

CRF_{Water} is the concentration reduction factor for water pathway transport (dimensionless); and

ρ_b^* is the bulk density of the grouted waste (2.4 g/cm³).

The maximum allowable concentration of the hazardous metal in water at the performance boundary, C_{Water} , is different for each hazardous metal and is shown in the Table 2-1. The CRF_{Source} accounts for the attenuation between the waste and the leachate exiting the bottom of the disposal facility. Estimates of CRF_{Source} values are the same for all 15 sites, and the method for estimating CRF_{Source} is described in Section 2.3.1. The CRF_{Water} accounts for the attenuation between the leachate exiting the disposal facility and the resulting concentration in water at the performance boundary. This term is analogous to the EPA's dilution attenuation factor (DAF) used in the soil screening rules. The method for estimating CRF_{Water} is described in Section 2.3.2. The values for CRF_{Water} are site-specific and are reported in the site-evaluation sections of Appendix B.

Estimates of the travel times of the hazardous metals to the performance boundary (t) were calculated as the sum of the retarded contaminant travel times in the vadose (unsaturated) and saturated zones by

$$t = t_{cv} + t_{cs} \quad (2-2)$$

where

t_{cv} is the retarded travel time of the contaminant from the disposal facility to the aquifer (y); and

t_{cs} is the retarded travel time of the contaminant through the saturated zone (y).

The method for estimating contaminant travel time is described in Section 2.3.4.

2.3.1 Source CRF

For a stabilized waste form, the source CRF, CRF_{Source} , was defined as

$$CRF_{Source} = C_W / C_L \quad (2-3)$$

where

C_W is the concentration in the grouted waste form for each hazardous metal averaged over the entire volume of waste in the disposal facility (mg/L), and

C_L is the corresponding concentration in the leachate for each hazardous metal as it exits the bottom of the disposal facility (mg/L).

The partitioning of hazardous metals between the solid phase (i.e., hazardous metals sorbed onto the grout) and the liquid phase (i.e., hazardous metals dissolved in the pore water) was assumed to be determined by equilibrium sorption. This assumption is consistent with analyses in the three LLW performance assessments that have evaluated grouted waste forms (ORNL, 1994; MMES et al., 1994; Kincaid et al., 1993). Based on this assumption, the hazardous metal concentration in the leachate due to desorption in infiltrating water can be described by (ORNL, 1994)

$$C_L = \frac{C_W f_m}{(\theta_G + K_d^G \rho_G)} \quad (2-4)$$

where

θ_G is the volumetric water content of the grouted waste form (excluding water of hydration) (mL/mL);

K_d^G is the distribution coefficient (i.e., solid/liquid partition coefficient) of the hazardous metal in the grout (mL/g);

ρ_G is the dry bulk density of the grouted waste form (excluding water of hydration) (g/cm^3); and

f_m is the mixing fraction, defined as the ratio of the volume of waste disposed of in a unit volume of the facility.

Combining Equations 2-3 and 2-4 derives a relationship for CRF_{Source} in terms of the properties of the stabilized waste (θ_G , ρ_G , and f_m) and the grout distribution coefficient (K_d^G):

$$CRF_{Source} = \frac{(\theta_G + K_d^G \rho_G)}{f_m} \quad (2-5)$$

Because the values for ρ_G , θ_G , and f_m are specific to the waste form (i.e., grout) and to the design of the disposal facility (i.e., trench) rather than to the site, the values used for these parameters in the scoping evaluation were the same for all 15 sites. These three parameters are described in Table 2-2.

Table 2-2. Summary of Grout and Facility Parameters That Affect the Source Term CRF (CRF_{Source}) (based on Waters et al., 1996, Table 5-2)

Parameter	Value	Comments
Grout Dry Bulk Density (ρ_G)	1.8 g/cm ³	The dry bulk density of grout is defined as the oven-dried mass per unit volume of grout. Value is based on Oak Ridge SWSA 6 performance assessment (ORNL, 1994).
Grout Volumetric Water Content (θ_G)	0.3	The volumetric water content of the grout is defined as the volume of water per unit volume of grout. The grout is assumed to be saturated, which reflects the hygroscopic nature of cementitious grouts. Under saturated conditions the water content and the porosity are the same.
Mixing Fraction (f_m)	2/3	This factor is the fraction of waste volume in the disposal facility (see Section 2.2.2).

Limited information exists on appropriate values for distribution coefficients in grout, in part because of the wide variety of methods used to measure waste leachability from different waste forms. Because of this variability, conservative K_d^G values (i.e., low K_d^G values that yield relatively high hazardous metal concentrations in the leachate) were used in the scoping evaluation. These values are based largely on the analysis in the Oak Ridge SWSA 6 performance assessment for low-level radioactive waste (ORNL, 1994). The grouted waste form considered in the formulation of K_d^G values in the Oak Ridge performance assessment was based on mixing dry waste with pumpable grout. Conversely, K_d^G values in the Hanford tanks performance assessment (Kincaid et al., 1993) and the Savannah River vaults performance assessment (MMES et al., 1994) were based on grout formulations in which radionuclides in water are mixed into the grout material. Much higher K_d^G values were used in the Savannah River and Hanford performance assessments than for Oak Ridge. The lower values used in the Oak Ridge performance assessment are more conservative in that they result in smaller values for CRF_{Source} ; thus, these values were used as the primary basis for the values for barium, cadmium, lead, and selenium in the scoping evaluation (Table 2-3).

The K_d^G values for arsenic and chromium were based on empirical metal-sediment partitioning relationships that were pH dependent with an assumed pH of 12.5 (Loux et al., 1990). The K_d^G value for mercury was based on geochemical modeling for the following conditions: high pH of solution, low pH in iron oxides, and matrix of natural organic content (EPA, 1992). The value for silver was based on the sorption database developed from European experience for the cementitious near-field of a low/intermediate-level waste repository (Bradbury and Sarott, 1995). Because of the high degree of associated uncertainty, the K_d^G values in the table are the result of rounding to the nearest order of magnitude. The resulting calculated values for CRF_{Source} are also shown in Table 2-3.

Table 2-3. Values for K_d^G for Hazardous Metals in Grout Used in the Scoping Evaluation and Resulting Concentration Reduction Factors for the Source (CRF_{Source}) (from ORNL, 1994 unless otherwise noted)

Hazardous Metal	K_d^G (mL/g)	CRF_{Source}
Arsenic (As)	10^a	27
Barium (Ba)	10	27
Cadmium (Cd)	100	270
Chromium (Cr)	10^a	27
Lead (Pb)	100	270
Mercury (Hg)	10^b	27
Selenium (Se)	1	3.2
Silver (Ag)	1^c	3.2

a Loux et al., 1990

b EPA, 1992

c Bradbury and Sarott, 1995

2.3.2 Water Pathway Transport CRF

A generic conceptual model was used in the scoping evaluation to describe the water pathway (Figure 2-3). For each site, site-specific geometry and water flow paths based on information provided by site technical staff were incorporated into a simple transport analysis.

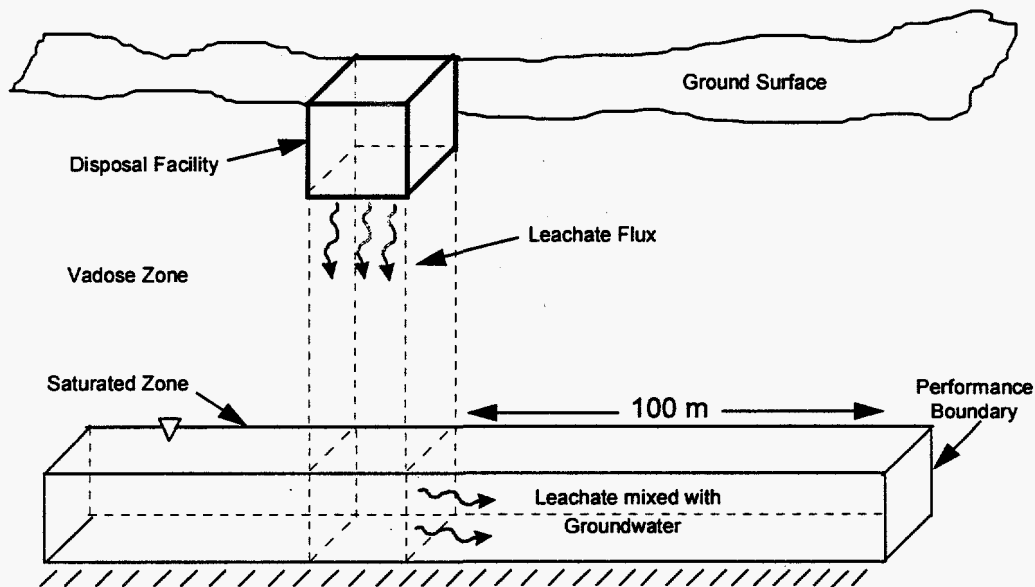

Figure 2-3. Generic conceptual model for the water pathway.

A number of assumptions related to flow and transport were made in the generic model. The most important of these are

- Steady-state flow in the vadose (unsaturated) and saturated zones.
- Continuous source release from the disposal facility with step increases at the times of failure of the engineered barriers (see Section 2.2.2).
- One-dimensional flow and transport in the vadose zone with no lateral spreading from diffusion or hydrodynamic dispersion. As a result of this assumption, the CRF for transport through the vadose zone is unity.
- Elimination of fractured sections from the analysis by reducing the vadose zone thickness when the relevant geologic formations in the vadose zone at a site were known to contain fractures. This procedure simplified the transport calculations and resulted in shorter estimates of travel time.
- Combination of fractured porosity and matrix porosity into an effective porosity when the relevant geologic formations in the saturated zone were known to contain fractures.
- One-dimensional flow and transport in the saturated zone with no diffusion or hydrodynamic dispersion in the longitudinal or transverse directions.
- Complete mixing across an appropriate depth representing dilution in the saturated zone.
- Sorption of dissolved hazardous metals on the porous media in both the vadose and saturated zones, resulting in retarded travel times of hazardous metals.

The assumption of a continuous release of hazardous metals from the disposal facility was used for two reasons. First, the hazardous metal inventory in the disposal facility is unknown, so the duration of release is also unknown; assuming a continuous-release source was conservative. Second, the assumption allowed the effects of longitudinal dispersion and diffusion on peak concentration in the vadose and saturated zones to be disregarded. The use of this assumption is discussed in more detail in Section 3.1.7.

The volumetric flow through the facility of water that generates leachate (Q_f) was based on the assumed performance and size of the facility. It is defined as

$$Q_f = q_f A \quad (2-6)$$

where

q_f is the rate of water moving through the facility (m/y); and
 A is the facility plan area (m^2) with length, a_1 , and width, a_2 (m).

As shown in Figure 2-2, q_f is controlled by the minimum of either the properties of the RCRA cover (the RCRA-regulated value of 10^{-7} cm/s) or natural recharge from 30 to 100 years. When all engineered barriers have failed at 100 years, q_f is assumed to be equal to the natural recharge through local soils, i .

No lateral spreading was assumed, so the leachate flux through the vadose zone is confined to the soil column directly below the plan area of the facility.

As contaminated water enters the aquifer, the contaminant was assumed to mix with uncontaminated groundwater, forming a plume with a shape controlled by aquifer and contaminant properties. Complete mixing within the aquifer was assumed to occur directly below the facility.

The dilution of contaminants by mixing with uncontaminated groundwater was the only attenuation effect in the water pathway, and the CRF is determined by

$$CRF_{water} = \frac{(Q_f + Q_{gw})}{Q_f} \quad (2-7)$$

where Q_{gw} is the volumetric groundwater flow (m^3/y), defined as

$$Q_{gw} = q_{gw} d_m a_2 \quad (2-8)$$

where

q_{gw} is the groundwater Darcy velocity (i.e., the volume discharge per unit bulk area) (m/y);
 d_m is the contaminant mixing depth in the groundwater (m); and
 a_2 is the width of the facility (m).

The contaminant mixing depth in the groundwater, d_m , was estimated according to aquifer properties. Thin aquifers were assumed to be completely mixed across their entire depth. For thicker aquifers, the mixing depth was estimated by the plume thickness due to vertical dispersion at 100 m from the facility. A one-dimensional flow, three-dimensional transport code (Chu et al., 1991) was used, with compiled estimates for dispersivity values (EPRI, 1985) based on the type of geologic formation in the saturated zone.

2.3.3 Solubilities of Hazardous Metals

A characteristic feature of most trace metals in aquatic environments is the tendency to form hydrolyzed and complexed species by combining with inorganic and organic complexes. The percent total concentration existing as hydrolyzed species increases with increasing pH of the water. Therefore, hydroxide (and/or carbonate) phases can be important solubility-controlling solids in neutral and alkaline geochemical environments. Solubility limits for trace metals under field conditions are affected by many factors related to the particular hydrogeological environment (e.g., pH and Eh of the solution, presence of complexing ligands, ion composition of groundwater, and chemical speciation of waste leachate).

Little information is available about the reactions of inorganic compounds in disposal facilities. Most discussions of solubilities generally consider compounds in terms of reducing/oxidizing conditions and pH. Although the formation of some chemical compounds in a disposal facility containing grouted MLLW may be predicted (e.g., $FeAsO_4$, $CdCO_3$, and $Cr(OH)_3$ [Rai and Zachara, 1984, Table S-2]), many of these compounds are relatively insoluble. The solubility values used for the hazardous metals in the scoping evaluation, therefore, were based on the reactions of the metals dissolved in groundwater (Fetter, 1993, Chapter 6). These

solubility values tended to be more conservative (i.e., greater) than those for compounds that have been predicted to be formed in disposal facilities. The compounds, their solubilities, and the solubilities of the associated metals are listed in Table 2-4. The metal solubilities were used in the scoping evaluation to determine whether inventory limits were appropriate for a particular hazardous metal: if the calculated maximum concentration of a hazardous metal in the leachate exiting the disposal facility at a site was greater than the solubility of the metal compound, the metal concentration was assumed to be solubility limited, and the maximum concentration of the metal in treated MLLW was considered to have "no limit."

Table 2-4. Solubility Values for Possible Hazardous Metal Compounds in a MLLW Disposal Facility and for the Associated Metals

Hazardous Metal	Compound		Solubility of Metal (mg/L)
	Chemical Formula ^a	Solubility ^b (mg/L)	
Arsenic (As)	As ₂ S ₃	0.5	0.3
Barium (Ba)	BaSO ₄	3	1.8
Cadmium (Cd)	CdS	1	0.8
Chromium (Cr)	CrSO ₄ · 7H ₂ O	1E+05	2.1E+04
Lead (Pb)	PbCO ₃	1	0.8
Mercury (Hg)	HgS	0.1	0.009
Selenium (Se)	SeO ₂	4E+06	2.8E+06
Silver (Ag)	AgCl	0.9	0.7

a Based on Fetter (1993, Chapter 6)

b Values from CRC (1985)

2.3.4 Estimation of Travel Time

The water travel time in the vadose (unsaturated) zone was estimated by

$$t_{wv} = \frac{l \theta_w}{q_f} \quad (2-9)$$

where

t_{wv} is the water travel time in the vadose zone for steady-state, one-dimensional flow under unit gradient conditions (y):

l is the distance between the disposal facility and the groundwater (m); and

θ_w is the volumetric moisture content in the vadose zone (mL/cm³).

Retarded travel time for a hazardous metal in the vadose zone was estimated by

$$t_{cv} = t_{vv} \left(1 + \frac{K_d \rho_b}{\theta_w} \right) \quad (2-10)$$

where

t_{cv} is the contaminant travel time from the disposal facility to the aquifer (y);
 K_d is the distribution coefficient (i.e., solid/liquid partition coefficient) of the hazardous metal in the vadose (unsaturated) zone (mL/g); and
 ρ_b is the dry bulk density of the soil in the vadose zone (g/cm^3).

The water travel time in the saturated zone was estimated by

$$t_{ws} = \frac{100 n}{q_{gw}} \quad (2-11)$$

where

t_{ws} is the water travel time in the saturated zone for steady-state, one-dimensional flow under unit gradient conditions (y);
 100 is the distance in the aquifer between the edge of the disposal facility and the performance boundary (m); and
 n is the porosity of the saturated zone.

Retarded contaminant travel time in the saturated zone (t_{cs}) was defined as

$$t_{cs} = t_{ws} \left(1 + \frac{K_d \rho_b}{n} \right). \quad (2-12)$$

The environmental chemistry of hazardous metals is relatively complex, and attempting to predict the transport behavior of trace metals within groundwater systems is difficult (Freeze and Cherry, 1979). For simplified analyses, the transport parameter of greatest importance for hazardous metals is the metal-soil distribution coefficient (K_d).

Whenever site-specific sorption parameters were available, these were used in the calculations of contaminant transport. The main sources for these data were site-specific radiological performance assessments and transport studies. If site-specific sorption data are available, they are presented in Appendix B in the site evaluation. However, for a number of sites, sorption data that are site-specific were not available.

A generic list of K_d values for hazardous metals was compiled for use in the scoping evaluation for those sites that had incomplete or no sorption data (Table 2-5). The general approach adopted in this study of selecting generic K_d values for hazardous metals is similar to one frequently used in performance assessments of radioactive-waste repositories: in the absence of reliable site-specific data, conservative estimates for sorption parameters were determined. Thus, in situations where no direct data existed, sorption data for materials that are known to be weaker adsorbents (e.g., sand and granite) than other geological materials were used. Also shown in Table 2-5 is general information about the chemical classification of each of the hazardous metals and their relative mobility.

Table 2-5. Generic Soil K_d Values Used in the Scoping Analysis

Hazardous Metal	K_d (mL/g)	Chemical Classification	Relative Mobility ^a	K_d Reference
Arsenic (As)	6	Anionic	High	Baes and Sharp, 1983
Barium (Ba)	500	Cationic	Low	Ashton and Sumerling, 1988
Cadmium (Cd)	80	Cationic	Medium	Sheppard and Thibault, 1990
Chromium (Cr)	70	Redox-sensitive	Medium	Sheppard and Thibault, 1990
Lead (Pb)	270	Cationic	Low	Sheppard and Thibault, 1990
Mercury (Hg)	100	Cationic	Medium	Estimate using data from Rai and Zachara, 1984
Selenium (Se)	8	Redox-sensitive	High	Vandergraaf and Ticknor, 1994
Silver (Ag)	90	Cationic	Medium	Sheppard and Thibault, 1990

^a Metals with a $K_d < 50$ mL/g are considered to have high mobility; those with a K_d of 50 to 100 mL/g are considered to have medium mobility; and those with a $K_d > 100$ are considered to have low mobility.

3. EFFECTS OF CONCEPTUAL MODEL ASSUMPTIONS AND PARAMETER SENSITIVITY

An examination of the major assumptions for the conceptual model used in the scoping evaluation for hazardous metals is summarized in this chapter. In addition, the results of the parameter sensitivity analysis conducted for the performance evaluation for radionuclides in treated MLLW (Waters et al., 1996, Sections 6.1 and 6.2) that are applicable to the scoping evaluation of hazardous metals are discussed here.

3.1 MAJOR ASSUMPTIONS USED IN CONCEPTUAL MODELS

The evaluation of hazardous metals was developed as a scoping tool. As such, many simplifying assumptions were used to develop the conceptual model for contaminant transport through the water pathway. Most of these simplifying assumptions tended to provide conservatism. For purposes of this discussion, conservative means that the maximum concentrations of hazardous metals in treated MLLW for disposal calculated by the method described in this report are likely to be lower than if a more detailed analysis were done.

3.1.1 Applicable Regulations

The performance measures are the maximum concentrations of hazardous metals permissible for groundwater protection that are identified in Table 1 of 40 CFR Part 264.94. However, in permits for hazardous waste disposal facilities, the EPA regional administrator may specify different concentration limits in groundwater for hazardous constituents identified in the permits. Should regulatory limits be set in the future that are different from the performance measures in this scoping evaluation, the results of the evaluation could be modified simply by multiplying the affected waste concentration by the ratio of the new and old concentrations and comparing the result to the solubility limit. The method used in the scoping evaluation has sufficient flexibility to accommodate such changes.

3.1.2 Waste Form and Performance

The choice of waste form significantly affects estimates of the maximum concentrations of hazardous metals in the waste. A grouted waste form was used in this analysis because it is expected to be a common waste form for treated MLLW disposal. However, from a performance perspective, the main effect of a more stable waste form (e.g., one resulting from vitrification) would be to increase the maximum concentrations of hazardous metals in the waste because the hazardous metals would be released more slowly. The framework of the modeling was designed to allow direct substitution of other waste form performance models.

3.1.3 Type of Disposal Facility

The type of disposal facility chosen for the scoping evaluation for hazardous metals was a trench design. This design is considered by many sites when planning a disposal facility. However, at some sites in the humid region of the country, more engineered disposal facilities are used; the tumulus design is used at ORR (ORNL, 1994) and the vault design is used at SRS

(MMES et al., 1994). These facilities are designed to minimize the contact of infiltrating water with the waste and may result in higher maximum concentrations of hazardous metals in waste.

Some sites lack a sufficiently thick vadose (unsaturated) zone to accommodate a trench design like that used in the scoping evaluation (e.g., ORR, PGDP, and PORTS). Although in the scoping evaluation the generic trench design was incorporated by allowing a portion to be above ground as a mounded trench, other facility designs could be used (e.g., the vault design considered at SRS, the tumulus design considered at ORR, or the generic tumulus design used in the performance evaluation of radionuclides in MLLW [DOE, 1996]). Using a facility design that is sited on the land surface would increase travel times to the performance boundary because of longer travel times through the vadose zone. Depending on the specifications for the engineered barriers, travel times could also be nominally increased by additional detention time of hazardous metals in the disposal facility (see Section 3.1.4).

3.1.4 Performance of Engineered Barriers

The design of the disposal facility in the scoping evaluation for hazardous metals included engineered barriers. A RCRA-specified, low-permeability cover and leachate collection system were assumed to preclude releases from the disposal site for the first 30 years following closure. The collection system was assumed to fail abruptly at 30 years after closure, at which time releases of hazardous metals were assumed possible for the following 70 years by infiltration through the RCRA cover into the facility. Infiltration through the RCRA cover was assumed to be the lesser of 1×10^{-7} cm/s (0.03 m/y) or the annual recharge through local soils. At 100 years after closure, infiltration through the trench facility was assumed to be the annual recharge through local soils. The 30 years of detention in the facility and 100 years of reduced infiltration into the facility may be an effective means for containment of short-lived radionuclides while they decay to insignificant levels. However, because hazardous metals do not decay as their radioactive counterparts do, this 100-y period only delays their maximum release rate and has essentially no effect on the resulting concentrations.

3.1.5 Solubility Constraints

Because the highest aqueous concentrations of hazardous metals estimated in the scoping evaluation are in the leachate exiting the disposal facility, the calculated concentrations of hazardous metals in the leachate for each site were compared to the solubilities of the associated metals. The leachate concentration was determined by dividing the maximum waste concentration of hazardous metals by the CRF_{Source} and multiplying by the bulk density.

The use of solubility limits is complicated by many factors, including the assumed chemical speciation of the element; interactions of multiple elements; and the conditions of pH and redox potential (Eh) in the aqueous environment, which changes from a grouted waste form with a high pH to a more pH-neutral groundwater. Depending on the assumed speciation, wide ranges of solubilities are possible for many hazardous metals. The exact chemical speciation of the hazardous metal is generally not known after disposal and therefore must be assumed. The uncertainty in solubilities that are based on assumed chemical forms of the hazardous metals can be very large. The compounds that were assumed to be present in the disposal facility in the

scoping evaluation are, in most cases, those that are expected to be formed in the presence of naturally infiltrating water of typical composition (Fetter, 1993, Chapter 6). These compounds and the solubilities of the associated hazardous metals are listed in Table 2-4.

Selection of solubility values is hampered by the lack of knowledge of environmental conditions, particularly pH and Eh, especially considering the large changes in conditions between a grouted waste and natural waters at a site. Solubility is a function of these parameters, and the lack of knowledge of long-term, site-specific conditions makes selection of solubilities for hazardous metals difficult.

3.1.6 Transport Retardation Model and Sorption Effects

The transport retardation model used in the scoping evaluation is based on the linear isotherm sorption model. In this model, contaminant sorption by the soil matrix is described by one parameter, the distribution coefficient, over the whole range of contaminant concentrations of interest. The drawback of this model is that it assumes that the sorption capacity of the sorbent is infinite, which is not correct. However, when considering trace concentrations of sorbing species in radiological performance assessments, this assumption is justified because sorption is linear at low concentrations of sorbing species (Vandergraaf and Ticknor, 1994).

In the scoping evaluation for hazardous metals, literature data (Rai and Zachara, 1984) for maximum soil sorption capacities (i.e., Langmuir maximum adsorption constants) for hazardous metals were compiled and compared to the maximum soil concentrations (i.e., the characteristic matrix soil loadings assumed in linear sorption) (Table 3-1). As shown in Table 3-1, in all cases these characteristic adsorbed concentrations are several orders of magnitude lower than the corresponding Langmuir maximum adsorption constants. Thus, using the linear sorption model in the scoping evaluation for hazardous metals is justified.

Table 3-1. Comparison of Maximum Soil Concentrations Used in the Scoping Evaluation with Maximum Sorption Capacities Reported in the Literature for RCRA Hazardous Metals

RCRA Hazardous Metal	Atomic Weight (g/mol)	Generic K_d (mL/g)	Maximum Soil Concentration ^a ($\mu\text{mol/g}$)	Langmuir Maximum Adsorption Constant ^b ($\mu\text{mol/g}$)
Arsenic (As)	74.92	6	0.004	3.3 - 4.4
Barium (Ba)	137.34	500	3.6	2050
Cadmium (Cd)	112.4	80	0.007	0.1 - 460
Chromium (Cr)	52	70	0.07	0.3 - 2700
Lead (Pb)	207.12	270	0.065	8 - 7000
Mercury (Hg)	200.59	100	0.001	1.6 - 237
Selenium (Se)	78.96	8	0.005	2 - 240

^a Soil concentration in equilibrium with solution concentration

^b Compiled from Rai and Zachara (1984)

Sorption was treated as a linear and reversible equilibrium process in the scoping evaluation, which resulted in retardation of the hazardous metals but no concentration attenuation because of the assumption of a continuous source. Other approaches have been used in LLW performance assessments that include processes that cause concentration attenuation during transport (e.g., partially irreversible sorption). Calculations for the LLW performance assessment at Oak Ridge were based on an vadose (unsaturated) zone sorption model that provided concentration attenuation proportional to the assumed partition coefficient and duration of release (ORNL, 1994). Calculations for the Hanford performance assessment of the 200 West Area (Wood et al., 1994b) were based on a sorption model that provided concentration attenuation proportional to the retardation factor, with larger values for the retardation factor resulting in increased concentration attenuation. The sorption model used in this scoping evaluation provided more conservative results than these two models by as much as two orders of magnitude (see Waters and Gruebel, 1996, Section A.4).

A wide variety of sorption models have been developed. However, most of these models require a considerable amount of knowledge of the nature of the sorbent, sorbate, and the solution chemistry, which is beyond the scope of this evaluation. This scoping evaluation incorporated a simple and widely used approach consisting of a linear model utilizing a distribution coefficient (K_d). As discussed by Galya (1987), when chemical dispersive effects are considered for a finite-duration source, sorption accentuates the dispersive concentration attenuation by slowing contaminant movement and providing more time for the dispersive effects to occur.

3.1.7 Continuous Source

Although in reality the duration of the source release will be limited by the hazardous metals inventory, a continuous source of hazardous metals from the disposal facility was assumed in the scoping evaluation because site-specific waste inventories were not known. With a continuous release source, the concentration at the base of the vadose zone eventually equals the leachate concentration, and the concentration in groundwater at the performance boundary eventually equals the concentration beyond the leachate-groundwater mixing zone. Also because of the continuous source, mechanical dispersion in the longitudinal direction affects the shape of the contaminant front but provides no attenuation of the concentration peak. Mechanical dispersion in the lateral transverse direction is a much weaker (10 to 100 times smaller) effect than dispersion in the longitudinal direction except under low-flow conditions (Freeze and Cherry, 1979, p. 396). While lateral transverse dispersion provides some attenuation of the centerline concentration peak, the effect is minor. That the effect is minor is particularly true for the calculations in this report because the distance to the compliance boundary of 100 m is small in comparison to the size of the disposal facility (50 m by 50 m in cross section). Transverse lateral dispersion would have negligible effect on centerline concentrations at the 100-m performance boundary.

The continuous source assumption can also affect attenuation in the subsurface. Calculations for the LLW performance assessment at Oak Ridge (ORNL, 1994) were based on the assumption that sorption effects in the vadose zone attenuated the dissolved radionuclide

concentrations in the subsurface. This attenuation effect is related to the duration of the source from the facility, with shorter source durations providing larger attenuation effects (Waters et al., 1996, Section A.3). The effect is more pronounced for hazardous metals with higher K_d values.

3.1.8 Treatment of Fracture Flow

Fractured geologic media is known to be present at a few of the sites analyzed in the scoping evaluation. When fractured media were known to be present in the vadose (unsaturated) zone, flow through these media was assumed to be complete and instantaneous. This approach is consistent with that used in the INEL performance assessment for LLW (Maheras et al., 1994). In general, due to capillary effects, only the smaller pores within the rock matrix contain water while the fractures contain air, with the result that fractures can be an effective barrier to flow and transport. Therefore, eliminating sections of the vadose zone from the conceptual model due to the presence of fractures may be extremely conservative because fractures tend not to transmit water except during extreme events such as flooding.

When fractured media were present in the saturated zone, flow through these media was assumed to be accounted for by pore velocity and contaminant travel times that were based on effective porosity and hydraulic conductivity. This approach is a common way of treating regional groundwater flow through fractured media because aquifer properties derived from field data typically result in these "effective" properties, based on averages over large portions of the aquifer. The physics and chemistry of flow and transport in fractured media are complex, and these simplifying assumptions provide a conservative approach to modeling their behavior.

3.1.9 Regional Recharge

In the scoping evaluation, the concentration in the saturated zone resulting from dilution of leachate with groundwater was assumed to be constant during transport to the 100-m performance boundary. Additional concentration dilution in the ORR performance assessment from the mixing of infiltrating water from regional recharge with the contaminated groundwater provided an additional concentration attenuation factor of about three (Waters and Gruebel, 1996, Section A.3). While this effect is quite small, dilution at ORR because of regional recharge provided more attenuation than dilution of leachate with groundwater. Sites with high recharge rates relative to groundwater flow and low CRF_{Water} values would benefit most from inclusion of dilution from regional recharge.

3.2 PARAMETER SENSITIVITY

In the performance evaluation for radionuclides in MLLW, the water pathway estimates of the permissible concentrations of radionuclides in the waste were shown to be relatively insensitive to variations in all but five parameters (grout distribution coefficient, K_d^G ; natural recharge rate, i ; groundwater Darcy velocity, q_{gw} ; plan area of the disposal facility, A ; and soil distribution coefficients, K_d) (Waters et al., 1996, Section 6.2). Differences in the values for the other parameters when varied to their practical maximums and minimums changed the estimates

of the permissible concentrations of radionuclides in the waste by less than an order of magnitude.

Only three of these five parameters (i , q_{gw} , and A) were important in the scoping evaluation for hazardous metals. Because generic values were used, variations in the grout distribution coefficient affect all sites in the same manner. Variations in soil K_d values were not important in this analysis but were important in the performance evaluation for radionuclides because radionuclides decay and the time period for consideration was 10,000 y.

The three parameters identified as important in the scoping evaluation for hazardous metals are used in the calculation of CRF_{Water} . Based on Equation 2-7 for CRF_{Water} , Equations 2-6 and 2-8 can be combined as

$$CRF_{Water} = \frac{q_{gw} d_m a_2}{q_f A} + 1 \quad (3-1)$$

where $q_f = i$ when all engineered barriers have failed. The exact effects on CRF_{Water} due to changes in the three parameters are site specific because the values for the parameters are site specific.

Changes in CRF_{Water} are inversely proportional to changes in i (i.e., increasing the recharge rate decreases dilution in groundwater). Because natural recharge is difficult to measure, it is potentially important with regard to sensitivity; however, estimating values for this parameter with a high degree of confidence was difficult for most sites considered in the scoping evaluation.

For the groundwater Darcy velocity, q_{gw} , changes in CRF_{Water} are generally proportional to changes in q_{gw} (i.e., increasing the groundwater velocity increases dilution).

Because the size of the disposal facility depends on the amount of waste to be disposed of at a site, the actual size of a facility may be much different than that assumed here. The disposal facility plan area, A , and facility width, a_2 , are generic parameters, and the same values were used in the scoping evaluation for all of the sites (2500 m² and 50 m, respectively). By assuming that the shape of the facility is square, changes in maximum concentrations of hazardous metals in treated MLLW are generally proportional to the inverse square root of the change in the area, A . Doubling the size of the disposal facility causes a reduction in the maximum concentration of a hazardous metal that is slightly smaller than the square root of the change in A .

4. RESULTS AND CONCLUSIONS

For the 8 hazardous metals considered in the scoping evaluation, site-by-site estimates of the maximum concentrations of the hazardous metals in treated MLLW that would not exceed their maximum allowable concentrations in groundwater are presented in Appendix B. These estimates were based on the methodology presented in Chapter 2. A summary of the conceptual model assumptions used in the analyses and parameter sensitivity analyses is presented in Chapter 3. Summarized in this chapter are the results of the analyses performed for all of the sites. The chapter also contains the conclusions that were reached on the basis of these results.

The scoping evaluation is focused on the disposal of hazardous metals in the physical and chemical forms expected to be present in treated and stabilized DOE MLLW. Many important issues related to treated MLLW disposal have not been considered in this analysis, including social, ethical, and policy factors, MLLW treatment performance and costs, and transportation risks and costs. These issues may be addressed in later phases of the planning process for MLLW disposal. The disposal performance of the radionuclides that will also be present in treated MLLW was previously addressed (DOE, 1996).

The evaluation represents a first-order scoping study only. The results are limited in applicability, having been developed for the sole purpose of comparing the various DOE sites on the basis of estimated limits of hazardous metal concentrations in treated MLLW that can be placed in a hypothetical disposal facility. The methodology provides a simple and conservative analysis that can be applied in a consistent manner to all of the sites.

The water pathway analysis was based on site-specific modification of a generic conceptual model for flow and transport of water containing hazardous metals and used a framework that provides consistency of analysis for all of the sites. The attenuation in the concentrations between the disposed waste and the performance boundary was represented by the source concentration reduction factor, CRF_{Source} , and the concentration reduction factor for the water pathway, CRF_{Water} . The CRF_{Source} represented the concentration attenuation between the disposed waste and the leachate exiting the disposal facility and was modeled as a process that incorporates desorption and infiltration. The CRF_{Water} represented the attenuation in concentrations of the hazardous metals between the leachate emerging from the waste and that in the groundwater reaching the 100-m performance boundary. It was modeled as a dilution of leachate in the groundwater flowing beneath the disposal facility.

4.1 SUMMARY OF NATURAL SITE CHARACTERISTICS

The scoping evaluation showed that the estimates of maximum concentrations of hazardous metals in treated MLLW were highly dependent on the subsurface geology and the natural characteristics of the site. Of these, the natural recharge rate is directly affected, and the depth to groundwater is affected to some extent, by the climate of the region in which the disposal facility is located. For this reason, the 15 sites were divided into arid and humid groups, with the former including LLNL, Hanford, NTS, INEL, RFETS, SNL, LANL, and Pantex and the

latter including ANLE, PGDP, FEMP, PORTS, ORR, SRS, and WVDP. Several important characteristics of the sites are shown in Figures 4-1 and 4-2.

For three of the sites, the subsurface geology was a special consideration in determining flow and transport through the vadose (unsaturated) zone. For LANL, ORR, and WVDP, portions of the geologic media in the vadose zone were not considered for various reasons. The maximum hazardous metals concentrations at these sites reflect the reduced total thickness of the vadose zone used in the scoping evaluation.

The natural recharge rate is used to estimate the amount of water passing through the disposal facility after the cover has failed. The recharge rate is also used to estimate the leachate velocity through the vadose zone. With the exception of NTS, estimated recharge rates range from less than 0.01 m/y at Pantex to 0.40 m/y at SRS. A recharge rate of zero is reported for NTS because hydrological investigation documents for the LLW facility at that site indicate that no net recharge occurs under current conditions. In general, the natural recharge rate for each site is determined by many factors including precipitation, evapotranspiration, surface topography and runoff, and the hydraulic conductivity of the subsurface geology. For example, ORR, which has the highest precipitation rate of all sites, has less than half the natural recharge of SRS due to the low hydraulic conductivity of the underlying formations and a hilly terrain that promotes surface and shallow subsurface runoff. As illustrated in Figure 4-1(a), with the exception of WVDP, which overlies a formation with very low hydraulic conductivity, the eastern sites have higher natural recharge rates than the western sites.

The depth to groundwater (Figure 4-1[b]) controls the time required for water and hazardous metals to reach the groundwater. At the 15 sites, this depth, commonly referred to as the "vadose (unsaturated)" or "vadose zone," ranges from 1 m at WVDP to 360 m (including the fractured zone) at LANL. With the exception of RFETS, the western sites generally have much thicker vadose zones than the eastern sites. The thickness of the vadose zones at LANL and ORR were assumed to be equal to the non-fractured portion only. The vadose zone at WVDP was not pertinent to the scoping evaluation; based on site practice, the disposal facility was located below the vadose zone.

The vertical and lateral components of water travel times are illustrated in Figure 4-2. In most instances, the vertical component of travel time is associated with travel time through the vadose zone. For PGDP and WVDP, however, at least some of the vertical travel is through the saturated zone before reaching the zone of lateral transport. For sites with relatively thick vadose zones (Figure 4-1[b]) (i.e., LLNL, Hanford, NTS, INEL, SNL, LANL, Pantex, and ANLE), the estimated vertical component of travel time through the vadose zone is 9 to 600 times larger than that for lateral travel. The SNL ratio of 9 is due to the low hydraulic gradient in the regional aquifer; this low gradient results in low groundwater velocities and thus, low dilution of leachate. The remaining sites have much thinner vadose zones, and the vertical and lateral components of travel times are on the same order of magnitude. The larger time for lateral travel in the saturated zone at WVDP is due to the low hydraulic conductivity of one formation and the low hydraulic gradient in the aquifer.

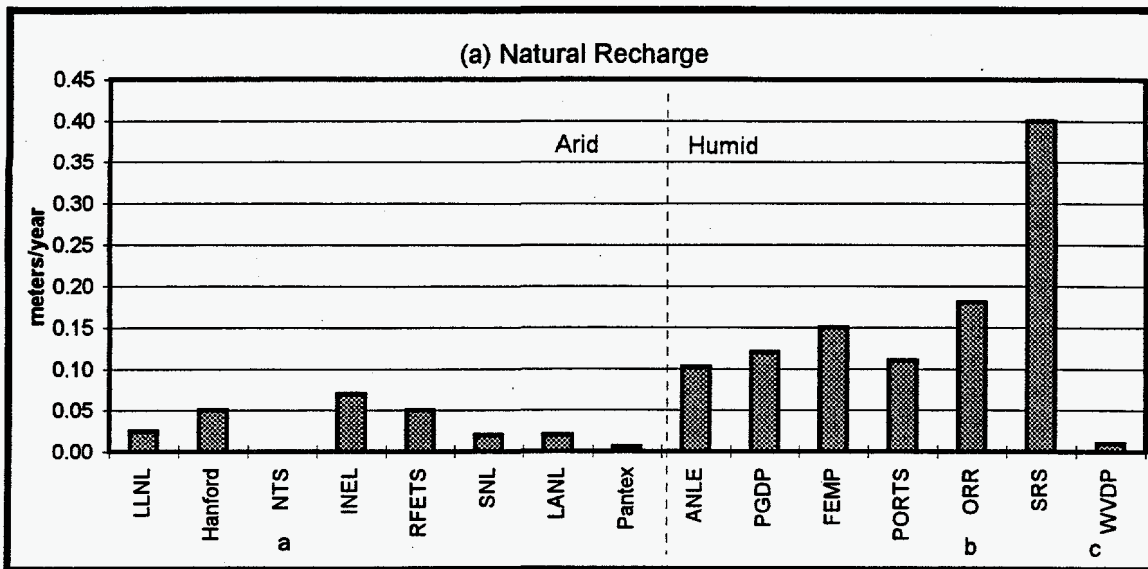

- a Hydrological investigation documents for the site indicate no net downward migration of water.
- b Movement of water through the disposal facility due to contributions from up-slope runoff is estimated to be 2.2 m/y. The majority of recharge flows laterally in the shallow subsurface, so that only 0.18 m/y contributes to the leachate flux entering the groundwater system.
- c Natural recharge is 0.07 m/y; the majority of recharge flows laterally in the weathered till, so that only 0.01 m/y contributes to the leachate flux entering the groundwater system.

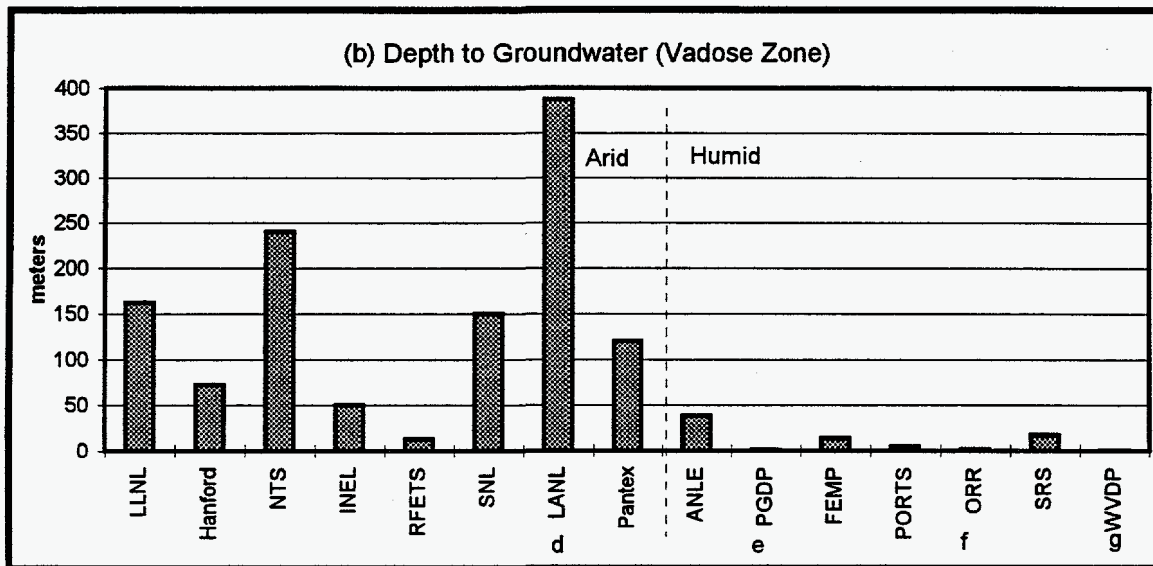

- d Unsaturated zone thickness used in the scoping evaluation is 333 m, which is the result of eliminating 27 m of fractured tuff from the conceptual model.
- e Unsaturated zone thickness is 1.5 m; depth to zone of horizontal transport is 15.5 m, which is the result of adding 1.5 m of unsaturated zone to 14 m of vertical transport through saturated media.
- f Unsaturated zone thickness used in the scoping evaluation is 0 m, which is the result of eliminating 2 m of fractured saprolite from the conceptual model.
- g Thickness of unsaturated zone is 1 m; based on site practice, trench is located 4 m below unsaturated/saturated zone interface and below near-surface zone of lateral transport.

Figure 4-1. Selected characteristics of the 15 sites (references for the natural recharge and depth to groundwater for each site are provided in Appendix B).

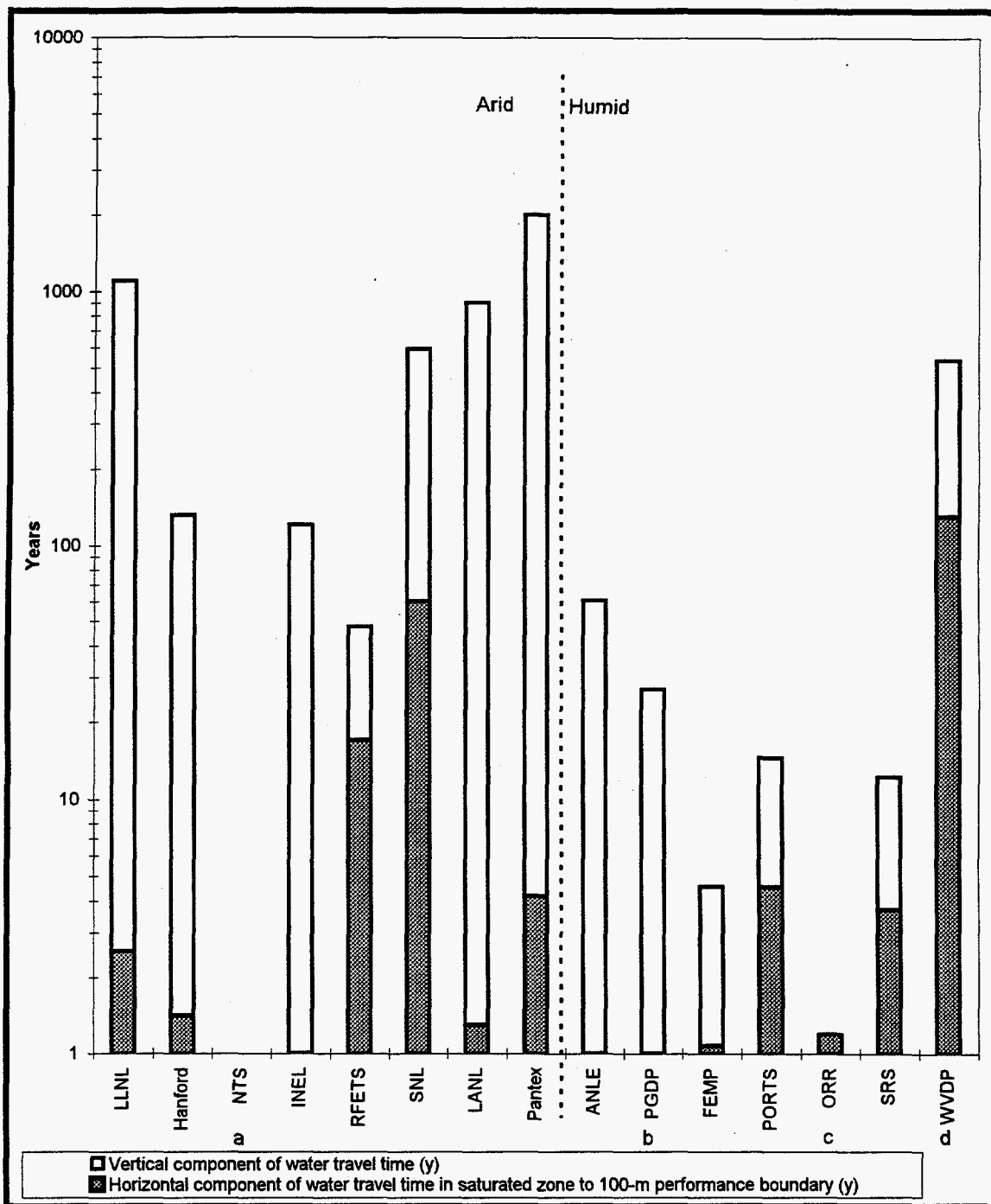

- a Hydrological investigation documents for the site indicate no net downward migration of water to the saturated zone.
- b Includes travel time through unsaturated zone and vertical component of travel time through saturated media to zone of horizontal transport.
- c Leachate flux exits disposal facility directly into the zone of horizontal transport.
- d The majority of recharge flows laterally in the weathered till—only 0.01 m/y contributes to the leachate entering the groundwater system.

Figure 4-2. Conservative estimates of vertical and lateral components of water travel times (y) based on this scoping evaluation of hazardous metals (see Appendix B).

These site characteristics are generally similar among the humid sites (high natural recharge and thin vadose zones) and the arid sites (low natural recharge and thick vadose zones), although there are some exceptions. For example, the vadose zone is relatively thin at RFETS although it is otherwise consistent with an arid site, and the recharge rate at WVDP is relatively low for a humid site. Based on these considerations, concentration limits for disposal of hazardous metals in humid regions will generally be more restrictive than those in arid regions.

The presence of certain natural characteristics at disposal sites can improve their performance relative to retarding the migration of hazardous metals. For example, if a disposal facility is underlain with a clay-rich formation having a large sorption capacity, the movement of hazardous metals may be significantly retarded even though water travel times may be short. For this reason, it is important to consider site-specific factors in conducting performance analyses. Such factors were considered to the extent possible in conducting the scoping evaluation while, at the same time, maintaining a consistent framework throughout the analyses.

4.2 SUMMARY OF RESULTS

A site-by-site summary of the maximum concentrations and travel times for each of the 8 hazardous metals is shown in Table 4-1. These values are from the summary tables for the site evaluations described in Appendix B. The observations based on the analyses contained in this report can be grouped into two categories: (1) performance of sites (Section 4.2.1) and (2) fate of hazardous metals (Section 4.2.2).

Some hazardous metals listed in Table 4-1 have no limit (NL) on their maximum concentration. Hazardous metals concentrations in treated MLLW were considered unlimited if their calculated leachate concentrations were greater than the solubilities of the associated metals. In addition, the hazardous metals concentrations for NTS were considered unlimited because research conducted at the site indicates that no net downward migration occurs at this site. The cells for which hazardous metals concentrations are considered unlimited are shaded gray in Table 4-1.

4.2.1 Performance of Sites

- Most of the arid sites had 5 or more maximum concentrations of hazardous metals in waste that were unlimited, due primarily to greater dilution (a combination of low recharge rates and moderate to rapid groundwater Darcy velocities). The exceptions are SNL, which had 3 unlimited concentrations, and RFETS, which had one unlimited concentration. At SNL and RFETS, the groundwater Darcy velocities are relatively slow (0.5 m/y and 0.59 m/y, respectively, as compared to LANL with 23 m/y), effectively resulting in less dilution.

Table 4-1. Summary of Maximum Hazardous Metals Concentrations in Treated MLLW

Site	Maximum Concentration in Treated MLLW (mg/kg)								
	Arsenic	Barium	Cadmium	Chromium	Lead	Mercury	Selenium	Silver	
Arid	LLNL	NL ♦	NL ♦	NL ♦	50 ♦	NL ♦	NL ♦	1 ♦	NL ♦
	Hanford	NL ♦	NL ♦	50 ♦	30 ♦	NL ♦	NL ♦	0.6 ■	NL ♦
	NTS ^a	—	—	—	—	—	—	—	—
	INEL	NL ♦	NL ♦	NL ♦	100 ♦	NL ♦	NL ♦	2 ●	NL ♦
	RFETS	2 ●	NL ♦	4 ♦	2 ♦	20 ♦	0.1 ♦	0.05 ●	0.2 ♦
	SNL	NL ♦	NL ♦	10 ♦	5 ♦	50 ♦	NL ♦	0.1 ♦	0.6 ♦
	LANL	NL ♦	NL ♦	NL ♦	100 ♦	NL ♦	NL ♦	3 ♦	NL ♦
	Pantex	NL ♦	NL ♦	NL ♦	100 ♦	NL ♦	NL ♦	3 ♦	NL ♦
Humid	ANLE	3 ●	NL ♦	5 ♦	3 ♦	30 ♦	NL ♦	0.1 ●	0.3 ♦
	PGDP	NL ♦	NL ♦	40 ♦	20 ♦	NL ♦	NL ♦	0.5 ●	NL ♦
	FEMP	NL ■	NL ♦	10 ●	7 ●	70 ♦	NL ●	0.2 ■	0.8 ●
	PORTS	3 ■	NL ♦	5 ●	3 ●	30 ●	NL ●	0.1 ■	0.3 ●
	ORR	1 ■	NL ♦	2 ●	1 ●	10 ♦	0.05 ●	0.03 ■	0.1 ●
	SRS	3 ■	NL ■	6 ■	3 ●	30 ●	NL ●	0.1 ■	0.3 ●
	WVDP	1 ●	20 ♦	2 ♦	1 ♦	9 ♦	0.04 ♦	0.02 ●	0.1 ♦

■ Contaminant travel time to the performance boundary less than 1000 y

● Contaminant travel time to the performance boundary 1000-10,000 y

♦ Contaminant travel time to the performance boundary greater than 10,000 y

^a Water pathway was not evaluated for this site

NL means "no limit": the maximum leachate concentration is greater than the solubility of the metal

Most of the humid sites had 3 or fewer maximum waste concentrations that were unlimited, due primarily to less dilution (a combination of high recharge rates and moderate to slow groundwater Darcy velocities). The exception is PGDP, which had 5 unlimited concentrations. At PGDP, the recharge rate is relatively low for a humid site (0.12 m/y) and the groundwater Darcy velocity is relatively fast (25 m/y).

- At the arid sites, travel times to the performance boundary for hazardous metals that were not solubility limited tended to be greater than 10,000 y. This trend is the result of relatively thick vadose (unsaturated) zones and low natural recharge. At RFETS, both arsenic and selenium have travel times between 1000 and 10,000 years, and at INEL, selenium has a travel time between 1000 and 10,000 years. These two sites have thinner vadose zones than the other arid sites.

At the humid sites, travel times to the performance boundary for hazardous metals that were not solubility limited tended to be greater than 1000 y but less than 10,000 y. This trend shows that even with relatively thin vadose zones and higher recharge rates, sorption provides

for relatively long travel times. However, for arsenic and selenium, travel times were estimated to be less than 1000 years for several sites, reflecting the relative mobility of these metals in the environment. Travel times to the performance boundary for 6 of the 8 hazardous metals at WVDP are greater than 10,000 years due to long travel times in the saturated zone.

4.2.2 Fate of Hazardous Metals

- Maximum concentrations in treated MLLW for two hazardous metals, barium and mercury, are unlimited at almost all of the sites. Maximum concentrations for barium are unlimited at all but one site because the performance measure in groundwater for the metal is large (1 mg/L), allowing maximum leachate concentrations to be greater than the solubility of the metal. Barium is not solubility limited at WVDP because the CRF_{Water} value for the metal is small. Because mercury has a very low solubility (0.009 mg/L), maximum concentrations of mercury in treated MLLW at most of the sites are unlimited. The exceptions are RFETS, ORR, and WVDP, which have the smallest CRF_{Water} values among the sites.
- Maximum concentrations in treated MLLW for chromium and selenium are limited at all sites except NTS. The solubilities of these two metals are very large (21,000 and 2.8 million mg/L, respectively). In the scoping analysis, calculated leachate concentrations ranged from 0.08 to 11 mg/L for chromium and from 0.02 to 2.2 mg/L for selenium. These ranges are well below the solubilities of the two metals.
- At almost all of the sites, travel times to the performance boundary for barium and lead were greater than 10,000 y. Travel times to the performance boundary for barium, with a relatively high environmental K_d value of 500 mL/g or greater for most of the sites, was greater than 10,000 years at all but two sites. At SRS, the travel time to the performance boundary for barium was less than 1000 y and at Hanford the travel time was between 1000 and 10,000 y, primarily because their site-specified environmental K_d values (5 mL/g and 1 mg/L, respectively) were considerably smaller than those used at most of the sites. Travel times to the performance boundary for lead, also with a relatively high environmental K_d value (greater than 250 mL/g at most of the evaluated sites), was greater than 10,000 years at all but two sites. At SRS and PORTS, travel time to the performance boundary for lead was between 1000 and 10,000 years. At SRS, this longer travel time was again due to a smaller, site-specified K_d value for lead (100 mL/g). At PORTS, the shorter travel time was due primarily to the short distance (1 m) from the bottom of the trench to groundwater.
- At all but four of the sites, the travel time to the performance boundary for selenium, which has a low environmental K_d value of 8 mL/g or less at the evaluated sites, was less than 10,000 years. The travel time to the performance boundary for selenium was greater than 10,000 years at four arid sites: LLNL, SNL, LANL, and Pantex. These four sites have the longest distances to groundwater of the sites included in the evaluation.

4.3 CONCLUSIONS

- All 15 DOE sites considered in this analysis have the technical capability for disposal of some hazardous metals in treated MLLW. This conclusion is based on the maximum concentrations of hazardous metals in treated MLLW that were estimated for the trench disposal facility. However, the technical capabilities for disposal of hazardous metals in treated mixed waste differ somewhat among the sites. For some hazardous metals, the range of the maximum concentrations among the sites spans two orders of magnitude.
- In general, travel times of the hazardous metals to the performance boundary were greater than 10,000 years at the arid sites and between 1000 and 10,000 years at the humid sites.
- Of the 8 hazardous metals evaluated in the analysis, barium and lead tended to be relatively immobile at both the arid and humid sites, while selenium tended to be the most mobile.
- The modeling in this analysis is believed to be conservative (i.e., provide lower maximum concentrations of hazardous metals allowed in treated MLLW and shorter travel times to the performance boundary) compared to more rigorous analyses. Therefore, in cases where maximum concentrations of hazardous metals in treated MLLW are high or unlimited, a more rigorous analysis would be of little additional benefit, provided performance measures similar to those assumed in this analysis were applied to future disposal facilities. However, in cases where maximum concentrations of hazardous metals in treated MLLW are relatively low (e.g., at ORR), more refined analyses that account for additional site-specific factors for transport of hazardous metals in water could result in higher maximum concentrations. Additionally, as site characterization continues and more information becomes available, exposure pathways other than those evaluated here might be identified that could also change the maximum concentrations of hazardous metals in treated MLLW.

The scoping evaluation was demonstrated as a useful tool that provides a readily available and simplified approach for representing important transport mechanisms. The methodology of the evaluation can also be used to identify the need for more detailed site-specific analyses that may be required to refine estimates of maximum concentrations of hazardous metals in treated MLLW.

The purpose of the analyses described in this report was to provide a scoping-level evaluation of the technical performance of a hypothetical disposal facility located at selected DOE sites with respect to the hazardous constituents in treated MLLW. Federal regulations for disposal of hazardous waste currently do not specifically require these types of analyses. Protection of the environment is implicitly assumed to be attained through a combination of prescriptive standards for treatment of hazardous wastes and design of disposal facilities to contain these wastes. States that have been delegated the authority to enforce the hazardous waste regulations under RCRA may, at their discretion, enact requirements that exceed those described in the federal regulations. At sites where disposal of MLLW is planned, application of the specific requirements of state and federal regulations will be addressed through site-specific performance assessments and other analyses required to demonstrate compliance with applicable regulations.

5. REFERENCES

- Ashton, J., and T.J. Sumerling, 1988. *Biosphere Database for Assessments of Radioactive Waste Disposal*. UK DOE rep. DOE/RW/88.083. London, UK: Department of the Environment.
- Baes III, C.F., and R.D. Sharp, 1983. "A Proposal for Estimation of Soil Leaching, and Leaching Constants for Use in Assessment Models," *Journal of Environmental Quality*. V. 12, pp. 17-28.
- Bradbury, Michael H., and Flurin-Andry Sarott, 1995. Sorption Database for the Cementitious Near-Field of a L/ILW Repository for Performance Assessment. PSI Ber. 95-06. Paul Scherrer Institut.
- Chu, M.S.Y., M.W. Kozak, J.E. Campbell, and B.M. Thompson, 1991. *A Self-Teaching Curriculum for the NRC/SNL Low-Level Waste Performance Assessment Methodology*. NUREG/CR-5539, SAND90-0585. Albuquerque, NM: Sandia National Laboratories.
- CRC (Chemical Rubber Company), 1985. *CRC Handbook of Chemistry and Physics*. Eds. Robert C. Weast and Melvin J. Astle. Boca Raton, FL: CRC Press, Inc.
- DOE (U.S. Department of Energy), 1988. "Low-Level Waste," Chap. III in *Radioactive Waste Management*, Order 5820.2A.
- DOE (U.S. Department of Energy), 1993. *U.S. Department of Energy Interim Mixed Waste Inventory Report: Waste Streams, Treatment Capacities and Technologies*. DOE/NBM-1100. Vol. 1.
- DOE (U.S. Department of Energy), 1996. *Performance Evaluation of the Technical Capabilities of DOE Sites for Disposal of Mixed Low-Level Waste*. DOE/ID-10521. 3 vol. Idaho Falls, ID: U.S. Department of Energy, Office of Waste Management (EM-30).
- EPA (U.S. Environmental Protection Agency), 1992. *Background Document for Finite Source Methodology for Waste Containing Metals*. Washington, DC: U.S. Environmental Protection Agency, Office of Solid Waste.
- EPI (Electric Power Research Institute), 1985. *A Review of Field-Scale Physical Solute Transport Processes in Saturated and Unsaturated Porous Media*. EPRI EA-4190. Norris, TN: Tennessee Valley Authority.
- FFCAct, 1992. Federal Facility Compliance Act (FFCAct) of 1992. P.L. 102-386, October 1992.
- Fetter, C.W., 1993. *Contaminant Hydrogeology*. New York, NY: Macmillan Publishing Company.

- Freeze, R.A., and J.A. Cherry, 1979. *Groundwater*. Prentice-Hall, Inc. 604 p.
- Galya, D.P., 1987. "A Horizontal Plane Source Model for Ground-Water Transport," *Ground Water*. Vol. 25, No. 6, pp. 733-739.
- INEL (Idaho National Engineering Laboratory), 1995. MWIR 1995, DOE National Mixed and TRU Waste Database User's Guide. DOE ILLW-233. Idaho Falls, ID: Radioactive Waste Technical Support Program, Lockheed Idaho Technologies Company.
- Kincaid, C.T., J.W. Shade, G.A. Whyatt, M.G. Piepho, K. Rhoads, J.A. Voogd, J.H. Westsik, Jr., M.D. Freshley, K.A. Blanchard, and B.G. Lauzon, eds., 1993. *Performance Assessment of Grouted Double-Shell Tank Waste Disposal at Hanford*. WHC-SD-WM-EE-004, Rev. 0. U.S. Department of Energy, Pacific Northwest Laboratory and Westinghouse Hanford Company.
- Loux, N.T., C.R. Chafin, and S.M. Hassan, 1990. *Statistics of Aquifer Material Properties and Empirical pH-dependent Partitioning Relationships for As, Ba, Be, Cd, Cr, Cu, Hg, Ni, Pb, Sb, Se, Tl, and Zn*. Athens, GA: U.S. Environmental Protection Agency.
- Maheras, Steven J., Arthur S. Rood, Swen O. Magnuson, Mary E. Sussman, and Rajiv N. Bhatt, 1994. *Radioactive Waste Management Complex Low-Level Waste Radiological Performance Assessment*. EGG-WM-8773. Idaho Falls, ID: U.S. Department of Energy Office of Environmental Restoration and Waste Management, DOE Idaho Operations Office.
- MMES (Martin Marietta Energy Systems, Inc.), EG&G Idaho, Inc., Westinghouse Hanford Company, and Westinghouse Savannah River Company, 1992. *Radiological Performance Assessment for the Z-Area Saltstone Disposal Facility (U)*. WSRC-RP-92-1360, Rev. 0. Aiken, SC: Westinghouse Savannah River Company.
- MMES (Martin Marietta Energy Systems), EG&G Idaho, Inc., and Westinghouse Savannah River Company, 1994. *Radiological Performance Assessment for the E-Area Vaults Disposal Facility (U)*. WSRC-RP-94-218, Rev. 0. Aiken, SC: Westinghouse Savannah River Company.
- ORNL (Oak Ridge National Laboratory), 1994. *Performance Assessment for Continuing and Future Operations at Solid Waste Storage Area 6*. ORNL-6783. Oak Ridge, TN: U.S. Department of Energy, Oak Ridge National Laboratory.
- Rai, D., and J.M. Zachara, 1984. *Chemical Attenuation Rates, Coefficients, and Constants in Leachate Migration, Volume I: A Critical Review*. EPRI EA-3356/1. Palo Alto, CA: Electric Power Research Institute.
- RCRA, 1976. *Resource Conservation and Recovery Act (RCRA) of 1976*, P.L. 94-580, Stat. 2795.
- Sheppard, M.I., and D.H. Thibault, 1990. "Default Soil Solid/Liquid Partition Coefficients, Kds, for Four Major Soil Types: A Compendium," *Health Physics*. V. 59, pp. 471-482.

Vandergraaf, T.T., and K.V. Ticknor, 1994. *A Compilation of Sorption Coefficients used in the Geosphere Model of SYVAC for the 1990 Assessment of the Whiteshell Research Area*. AECL-10546. Pinawa, Manitoba, Canada: Whiteshell Laboratories.

Waters, Robert D., and Marilyn M. Gruebel, eds., 1996. *Performance Evaluation of the Technical Capabilities of DOE Sites for Disposal of Mixed Low-Level Waste—Volume 3: Site Evaluations*. DOE/ID-10521/3. Idaho Falls, ID: U.S. Department of Energy, Office of Waste Management (EM-30).

Waters, Robert D., Marilyn M. Gruebel, Maryann B. Hospelhorn, Alva M. Parsons, Bruce M. Thomson, Margaret S.Y. Chu, Gregory P. Zimmerman, John D. Tauxe, Douglas A. Lombardi, Maria L. Socolof, James C. Wang, David Kocher, and Donald W. Lee, 1996. *Performance Evaluation of the Technical Capabilities of DOE Sites for Disposal of Mixed Low-Level Waste—Volume 2: Technical Basis and Discussion of Results*. DOE/ID-10521/2. Idaho Falls, ID: U.S. Department of Energy, Office of Waste Management (EM-30).

Waters, Robert D., Marilyn M. Gruebel, Brenda S. Langkopf, and Paul B. Kuehne, 1997. *Analysis of the Technical Capabilities of DOE Sites for Disposal of Residuals from the Treatment of Mixed Low-Level Waste*. SAND97-1098. Albuquerque, NM: Sandia National Laboratories.

Wood, D. E., R. U. Curl, D. R. Armstrong, J. R. Cook, M. R. Dolenc, D. C. Kocher, K. W. Owens, E. P. Regnier, G. W. Roles, R. R. Seitz, and M. I. Wood, 1994a. *Performance Assessment Task Team Progress Report*. DOE/LLW-157, Rev. 1. Idaho Falls, ID: Idaho National Engineering Laboratory.

Wood, M. W., R. Khaleel, P. D. Rittman, A. H. Lu, S. H. Finfrock, R. J. Serne, K. J. Cantrell, T. H. DeLorenzo, 1994b. *Performance Assessment for the Disposal of Low-Level Waste in the 200 West Area Burial Grounds*, WHC-EP-0645, prepared for the U. S. Department of Energy, Office of Environmental Restoration and Waste Management by Westinghouse Hanford Company, Richland, Wash.

Intentionally left blank

Appendix A:

Hazardous Constituents in Treated Mixed Low-Level Waste

Intentionally left blank

A.

Hazardous Constituents in Treated Mixed Low-Level Waste

Because they cannot be broken down to a more fundamental level, hazardous metals are expected to be present in treated mixed low-level waste (MLLW) regardless of the method of treatment, while the presence of hazardous organic constituents will depend on the method of treatment. Some treatment processes either destroy or remove essentially all hazardous organic constituents while other treatment processes (e.g., direct stabilization) do not.

A database created by merging U.S. Department of Energy's (DOE's) Mixed Waste Inventory Report (MWIR) database and the Site Treatment Plan (STP) database was used to assess the hazardous constituents expected to be in treated MLLW. This new database contains all MLLW streams and their volumes, hazardous constituents, characterization data, and associated site-specific plans for treatment. The procedure used to query the database, which is presented in greater detail below, is summarized here.

- The waste streams were sorted based on presence or absence of hazardous organic constituents, and the volumes of waste associated with these two categories were identified. In addition, some waste streams had either no associated treatment process or unidentified hazardous constituents. These waste streams were a small volume percentage of the total waste streams and were eliminated from further consideration.
- The waste streams that contain hazardous organic constituents were further sorted based on waste type and whether the treatment process was expected to destroy or remove all appreciable hazardous organics.
- The specific hazardous constituents associated with each of these different categories of waste were identified.

Sorting on the Presence of Hazardous Organic Constituents

The waste streams were sorted using a portion of the contaminant parameter category (CPC) field in the database. The CPC includes information related to the regulatory classification of the waste, the presence of hazardous organics and metals, and the presence of ignitable, corrosive, or reactive components (Kirkpatrick, 1995). The portion of the CPC indicating the presence of hazardous organics (code O11) was the sort value. The results are shown in Table A-1.

Approximately 60% by volume of the current inventory and 70% by volume of the projected inventory contain hazardous organic wastes. Approximately 5% by volume of current inventory and 14% by volume of the projected inventory had components that were not identifiable.

Table A-1. Volumes of MLLW Streams

Category	Current Inventory (m ³)	Projected Inventory (m ³)
Hazardous Organics Present	63,238	18,148
Hazardous Organics Not Present	42,210	4,516
Not Identifiable	4,978	3,644
Totals	110,426	26,308

The U.S. Environmental Protection Agency (EPA) hazardous waste codes (Kirkpatrick, 1995) were used to associate the specific hazardous constituents to the waste streams. Some waste streams in the database could not be evaluated because they had no associated Resource Conservation and Recovery Act (RCRA) codes. Other waste streams could not be evaluated because they used state codes in lieu of RCRA codes and the hazardous constituents associated with these state codes were not readily available. Lastly, some waste streams did not have treatment processes associated with them and could not be evaluated. These waste streams are the "Not Identifiable" category of Table A-1 and are summarized in Table A-2. The volume totals are equal to the values in Table A-1 for "Not Identifiable" waste. These wastes represent only about 6% of the entire MLLW current and projected inventory and were not considered further.

Table A-2. Volumes of MLLW Streams for Which Treatment Processes Have Not Been Identified or for Which Only State Codes Are Available

Process Flow to Be Determined	Current Inventory (m ³)	Projected Inventory (m ³)
Debris	3385	442
Encapsulation	0	1065
Inorganic Homogeneous Solids and Soils	689	2008
Unique	895	128
Wastes with State Codes	9	1
Total	4978	3644

Sorting on Treatments that Destroy or Remove the Hazardous Organics

Some of the waste streams that contain hazardous organics will be treated by processes that are expected either to destroy or remove essentially all of the hazardous organic constituents. All treatment processes other than direct stabilization and mercury amalgamation were considered either to destroy or remove the hazardous organics. The waste volumes associated with these treatment processes are given in Table A-3.

Table A-3. Process Flows for Which Hazardous Organics Are Assumed To Be Destroyed or Removed

Waste Type, Process Flow	Current Inventory (m ³)	Projected Inventory (m ³)
Combustible Organics, Non-Thermal	247	1362
Combustible Organics, Thermal	2311	1185
Compressed gases/aerosols, Thermal oxidation	8	0
Debris, Non-Thermal	1273	1002
Debris, Thermal	20,321	5356
Debris, Thermal Desorption	64	16
Inorganic Homogeneous Solids and Soils, Extraction/Oxidation	184	158
Inorganic Homogeneous Solids and Soils, Thermal	3801	55
Inorganic Homogeneous Solids and Soils, Thermal Desorption	5085	498
Lab Packs, Chemical Oxidation	9	7
Lab Packs, Thermal Oxidation	219	191
Wastewater, Non-Thermal	751	1034
Wastewater, Thermal Treatment	597	366
Total	34,870	11,230

Direct stabilization and mercury amalgamation are not expected to destroy or remove the hazardous organics. The waste volumes associated with these treatment processes are given in Table A-4.

Table A-4. Process Flows for Which Hazardous Organics Are Assumed Not To Be Destroyed or Removed

Waste Type, Process Flow	Current Inventory (m ³)	Projected Inventory (m ³)
Debris, Stabilization	812	2757
Elemental mercury, Amalgamation	1	0
Inorganic Homogeneous Solids and Soils, Stabilization	27,520	4146
Lab Packs, Stabilization	28	14
Lead, cadmium, beryllium, and other hazardous metals	7	2
Total	28,368	6,919

Over 97% by volume of the current inventory of waste streams that contain hazardous organic constituents that will not be destroyed or removed by treatment are in the "Inorganic Homogeneous Solids and Soils" category. Of these, approximately 75% by volume are inorganic

homogeneous solids and approximately 25% by volume are soil, gravel, or debris (Table A-5), for which organics are typically present in trace quantities.

Table A-5. Volumes of Waste Classified as Inorganic Homogeneous Solids and Soils for Which Hazardous Organics Are Assumed Not To Be Destroyed or Removed

Residual Waste Stream	Current Inventory (m ³)	Projected Inventory (m ³)
Organic Liquids	10	2
Inorganic Homogeneous Solids	20,710	3,724
Organic Homogeneous Solids	2	0
Soil/Gravel	6461	66
Soil	54	200
Soil/Debris	122	153
Unknown/Other Soil/Gravel	155	0
Inorganic Debris	6	0
Total	27,520	4,145

Identify Specific Hazardous Constituents

The hazardous constituents that are expected to be in treated MLLW are those that are present in MLLW and are not removed or destroyed by treatment. For the hazardous waste streams that do not contain hazardous organics and those containing hazardous organics that are not removed or destroyed by treatment, all the hazardous constituents associated with these wastes were identified. For the waste streams that contain hazardous organics that are assumed to be destroyed or removed by treatment, the hazardous metals associated with the waste streams were identified. All the hazardous constituents expected to remain in treated MLLW are shown in Table A-6. Due to limitations in the database, the volumes of waste associated with these hazardous waste constituents cannot be estimated.

References

Kirkpatrick, T.D., 1995. *DOE Waste Treatability Group Guidance*, Rev. 0. DOE/LLW-217. Idaho Falls, ID: Idaho National Engineering Laboratory, Lockheed Idaho Technology Company.

Table A-6. Constituents Expected to be Present in Disposed DOE MLLW (Part 1 of 2)

EPA Code	present in			Chemical Name
	A	B	C	
D004	•	•	•	Arsenic
D005	•	•	•	Barium
D006	•	•	•	Cadmium
D007	•	•	•	Chromium
D008	•	•	•	Lead
D009	•	•	•	Mercury
D010	•	•	•	Selenium
D011	•	•	•	Silver
D012			•	Endrin
D015			•	Toxaphene
D016			•	2,4-D
D018			•	Benzene
D019			•	Carbon tetrachloride
D020			•	Chlordane
D021			•	Chlorobenzene
D022			•	Chloroform
D023			•	o-cresol
D024			•	m-cresol
D025			•	p-cresol
D026			•	Cresol
D027			•	1,4-dichlorobenzene
D028			•	1,2-dichloroethane
D029			•	1,1-dichloroethylene
D030			•	2,4-dinitrotoluene
D031			•	Heptachlor
D032			•	Hexachlorobenzene
D033			•	Hexachlorobutadiene
D034			•	Hexachloroethane
D035			•	Methyl ethyl ketone
D036			•	Nitrobenzene
D037			•	Pentachlorophenol
D038			•	Pyridine
D039			•	Tetrachloroethylene
D040			•	Trichloroethylene
D041			•	2,4,5-trichlorophenol
D042			•	2,4,6-trichlorophenol
D043			•	Vinyl chloride
F001			•	1,1,1-trichloroethane; Tetrachloroethylene; Carbon tetrachloride; Trichloroethylene; Methylene chloride

EPA Code	present in			Chemical Name
	A	B	C	
F002			•	1,1,2-trichloro- 1,2,2-trifluoroethane; Methylene chloride; 1,1,1-trichloroethane; Trichloroethylene; Chlorobenzene; Ortho-dichlorobenzene; Trichlorofluoromethane; 1,1,2-trichloroethane; Tetrachloroethylene
F003			•	Ethyl ether; Ethyl benzene; n-butyl alcohol; Cyclohexanone; Methanol; Methyl isobutyl ketone; Ethyl acetate; Acetone; Xylene
F004			•	Cresol; Cresylic acid; Nitrobenzene
F005			•	Pyridine; Toluene; 2-nitropropane; Benzene; Methyl ethyl ketone; Carbon disulfide; Isobutanol; 2-ethoxyethanol
F006	•		•	Cadmium, chromium, lead, nickel, silver; Plating waste- if cyanides used in process
F007	•	•	•	Cadmium, chromium, lead, nickel, silver; Plating waste
F008	•	•	•	Cadmium, chromium, lead, nickel, silver; Plating waste
F009	•		•	Cadmium, chromium, lead, nickel, silver; Plating waste
F010			•	Cyanide (salts)
F011		•	•	Cadmium, chromium, lead, nickel, silver
F039			•	Multiple organic com- pounds, including tetra-, penta-, and hexachlorodibenzo-dioxins; tetra-, penta-, and hexachlorodibenzo-furans (leachate from hazardous waste disposal);antimony, arsenic, barium, beryllium, cadmium, chromium, copper, lead, mercury, nickel, selenium, silver, thallium, vanadium, and zinc

- A - Waste Streams with No Hazardous Organic Constituents
- B - Waste Streams with Hazardous Organic Constituents that Have Been Removed or Destroyed by Treatment
- C - Waste Streams with Hazardous Organic Constituents that Have Not Been Removed or Destroyed by Treatment

Table A-6. Constituents Expected to be Present in Disposed DOE MLLW (Part 2 of 2)

EPA Code	present in			Chemical Name
	A	B	C	
P010		•	•	Arsenic acid
P011	•	•	•	Arsenic pentoxide
P012	•	•	•	Arsenic trioxide
P015	•	•	•	Beryllium dust
P022			•	Carbon disulfide
P023			•	Chloroacetaldehyde
P029			•	Copper cyanide
P030			•	Cyanides (soluble salts, complexes)
P051			•	Endrin
P063			•	Hydrogen cyanide
P073	•		•	Nickel carbonyl
P074		•	•	Nickel cyanide
P087	•	•	•	Osmium tetroxide
P092		•	•	Phenyl mercury acetate
P098			•	Potassium cyanide
P104	•	•	•	Silver cyanide
P106			•	Sodium cyanide
P108			•	Strychnine and salts
P113	•	•	•	Thallic oxide
P119	•	•	•	Ammonia vanadate
P120	•	•	•	Vanadium petoxide
P121			•	Zinc cyanide
P122			•	Zinc phosphide
P123			•	Toxaphene
U001			•	Acetaldehyde
U002			•	Acetone
U003			•	Acetonitrile
U011			•	Amitrole
U018			•	Benz(a)anthracene
U019			•	Benzene
U025			•	bis(2-chloroethyl) ether
U026			•	Chlornaphazin
U031			•	n-butyl alcohol
U032	•	•	•	Calcium chromate
U036			•	Chlordane (alpha & gamma)
U037			•	Chlorobenzene
U041			•	1-chloro-2,3-epoxypropane
U043			•	Vinyl chloride
U044			•	Chloroform
U050			•	Chrysene
U052			•	Cresol (cresylic acid)
U056			•	Cyclohexane
U069			•	Di-n-butyl phthalate
U070			•	o-dichlorobenzene
U075			•	Dichlorodifluoromethane
U077			•	1,2-dichloroethane
U078			•	1,1-dichloroethylene
U079			•	1,2-dichloroethylene
U080			•	Methylene chloride
U103			•	Dimethyl sulfate

EPA Code	present in			Chemical Name
	A	B	C	
U107			•	Di-n-octyl phthalate
U108			•	1,4-dioxane
U112			•	Ethyl acetate
U117			•	Ethyl ether
U121			•	Trichloromonofluoromethane
U123			•	Formic acid
U127			•	Hexachlorobenzene
U131			•	Hexachloroethane
U134			•	Hydrofluoric acid
U135			•	Hydrogen sulfide
U136	•		•	Cacodylic acid
U144	•	•	•	Lead acetate
U145		•	•	Lead phosphate
U146	•		•	Lead subacetate
U151		•	•	Mercury
U154			•	Methanol
U157			•	3-methylchloanthrene
U159			•	Methyl ethyl ketone
U160			•	Methyl ethyl ketone peroxide
U161			•	Methyl isobutyl ketone
U166			•	1,4-naphthoquinone
U170			•	4-nitrophenol
U188			•	Phenol
U196			•	Pyridine
U201			•	Resorcinol
U204	•	•	•	Selenium dioxide
U210			•	Tetrachlorethylene
U211			•	Carbon tetrachloride
U213			•	Tetrahydrofuran
U214		•	•	Thallium (I) acetate
U215	•	•	•	Thallium (I) carbonate
U216	•	•	•	Thallium (I) chloride
U217	•	•	•	Thallium (I) nitrate
U219			•	Thiourea
U220			•	Toluene
U226			•	1,1,1-trichloroethane
U228			•	Trichloroethylene
U234			•	sym-trinitrobenzene
U236			•	Trypan blue
U237			•	Uracil mustard
U239			•	Xylenes
U240			•	2,4-dichlorophenoxyacetic acid
U328			•	Benzenamine, 2-methyl
U359			•	2-ethoxyethanol

- A - Waste Streams with No Hazardous Organic Constituents
- B - Waste Streams with Hazardous Organic Constituents that Have Been Removed or Destroyed by Treatment
- C - Waste Streams with Hazardous Organic Constituents that Have Not Been Removed or Destroyed by Treatment

Appendix B:
Site Evaluations

Intentionally left blank

Contents

B.1 California: LAWRENCE LIVERMORE NATIONAL LABORATORY SITE 300 (LLNL)	B-7
B.1.1 Conceptual Model and Site-Specific Data Used in the Scoping Evaluation	B-7
B.1.2 Results of the Scoping Evaluation	B-10
B.2 Colorado: ROCKY FLATS ENVIRONMENTAL TECHNOLOGY SITE (RFETS)	B-12
B.2.1 Conceptual Model and Site-Specific Data Used in the Scoping Evaluation	B-12
B.2.2 Results of the Scoping Evaluation	B-15
B.3 Idaho: IDAHO NATIONAL ENGINEERING LABORATORY (INEL)	B-17
B.3.1 Conceptual Model and Site-Specific Data Used in the Scoping Evaluation	B-17
B.3.2 Results of the Scoping Evaluation	B-20
B.4 Illinois: ARGONNE NATIONAL LABORATORY—EAST (ANLE)	B-22
B.4.1 Conceptual Model and Site-Specific Data Used in the Scoping Evaluation	B-22
B.4.2 Results of the Scoping Evaluation	B-25
B.5 Kentucky: PADUCAH GASEOUS DIFFUSION PLANT (PGDP)	B-27
B.5.1 Conceptual Model and Site-Specific Data Used in the Scoping Evaluation	B-27
B.5.2 Results of the Scoping Evaluation	B-30
B.6 Nevada: NEVADA TEST SITE (NTS)	B-32
B.7 New Mexico: LOS ALAMOS NATIONAL LABORATORY (LANL)	B-33
B.7.1 Conceptual Model and Site-Specific Data Used in the Scoping Evaluation	B-33
B.7.2 Results of the Scoping Evaluation	B-37
B.8 New Mexico: SANDIA NATIONAL LABORATORIES (SNL)	B-40
B.8.1 Conceptual Model and Site-Specific Data Used in the Scoping Evaluation	B-40
B.8.2 Results of the Scoping Evaluation	B-43
B.9 New York: WEST VALLEY DEMONSTRATION PROJECT (WVDP)	B-45
B.9.1 Conceptual Model and Site-Specific Data Used in the Scoping Evaluation	B-45
B.9.2 Results of the Scoping Evaluation	B-49
B.10 Ohio: FERNALD ENVIRONMENTAL MANAGEMENT PROJECT (FEMP)	B-51
B.10.1 Conceptual Model and Site-Specific Data Used in the PE	B-51
B.10.2 Results of the Scoping Evaluation	B-54
B.11 Ohio: PORTSMOUTH GASEOUS DIFFUSION PLANT (PORTS)	B-56
B.11.1 Conceptual Model and Site-Specific Data Used in the Scoping Evaluation	B-56
B.11.2 Results of the Scoping Evaluation	B-59
B.12 South Carolina: SAVANNAH RIVER SITE (SRS)	B-61
B.12.1 Conceptual Model and Site-Specific Data Used in the Scoping Evaluation	B-61
B.12.2 Results of the Scoping Evaluation	B-64
B.13 Tennessee: OAK RIDGE RESERVATION (ORR)	B-67
B.13.1 Conceptual Model and Site-Specific Data Used in the Scoping Evaluation	B-67
B.13.2 Results of the Scoping Evaluation	B-72
B.14 Texas: PANTEX PLANT	B-74
B.14.1 Conceptual Model and Site-Specific Data Used in the Scoping Evaluation	B-74
B.14.2 Results of the Scoping Evaluation	B-77
B.15 Washington: HANFORD SITE	B-79
B.15.1 Conceptual Model and Site-Specific Data Used in the Scoping Evaluation	B-79
B.15.2 Results of the Scoping Evaluation	B-83
B.16 References	B-85

Figures

Figure B-1. Site map for Lawrence Livermore National Laboratory Site 300.....	B-8
Figure B-2. Conceptual model for the water pathway at LLNL.....	B-9
Figure B-3. Site map for Rocky Flats Environmental Technology Site.....	B-13
Figure B-4. Conceptual model for the water pathway at RFETS.....	B-14
Figure B-5. Site map for the Idaho National Engineering Laboratory.....	B-18
Figure B-6. Conceptual model for the water pathway at INEL.....	B-19
Figure B-7. General location near the 800 Area Landfill for the generic MLLW disposal facility at ANLE.....	B-23
Figure B-8. Conceptual model for the water pathway at ANLE.....	B-24
Figure B-9. Possible MLLW disposal sites identified by the PGDP technical staff.....	B-28
Figure B-10. Conceptual model for the water pathway at PGDP.....	B-29
Figure B-11. Site map for Los Alamos National Laboratory.....	B-34
Figure B-12. Conceptual model for the water pathway at LANL.....	B-35
Figure B-13. Location of the Radioactive and Mixed Waste Management Facility and the Chemical Waste Landfill in Technical Area III at SNL.....	B-41
Figure B-14. Conceptual model for the water pathway at SNL.....	B-42
Figure B-15. General location of the hypothetical disposal facility at the WVDP.....	B-46
Figure B-16. Conceptual model for the water pathway at WVDP.....	B-47
Figure B-17. Site map for the Fernald Environmental Management Project.....	B-52
Figure B-18. Conceptual model for the water pathway at FEMP.....	B-53
Figure B-19. Possible MLLW disposal sites (north, east, and south) at PORTS.....	B-57
Figure B-20. Conceptual model for the water pathway at PORTS.....	B-58
Figure B-21. Location of the proposed mixed waste disposal facility (MWDF) within the E-Area at the Savannah River Site.....	B-62
Figure B-22. Conceptual model for the water pathway at SRS.....	B-63
Figure B-23. Site map for Oak Ridge Reservation.....	B-68
Figure B-24. Conceptual model for the water pathway at ORR.....	B-69
Figure B-25. Site map for Pantex Plant.....	B-75
Figure B-26. Conceptual model for the water pathway at the Pantex Plant.....	B-76
Figure B-27. Location of the proposed mixed waste disposal facility within the 200 West Area at the Hanford Site.....	B-80
Figure B-28. Conceptual model for the water pathway at Hanford.....	B-81

Tables

Table B-1. Site-Specific Parameters and Values Used in the Scoping Evaluation for the Water Pathway at LLNL	B-9
Table B-2. Results of Calculations for the Water Pathway at LLNL	B-11
Table B-3. Site-Specific Parameters and Values Used in the Scoping Evaluation for the Water Pathway at RFETS	B-14
Table B-4. Results of Calculations for the Water Pathway at RFETS	B-16
Table B-5. Site-Specific Parameters and Values Used in the Scoping Evaluation for the Water Pathway at INEL	B-19
Table B-6. Results of Calculations for the Water Pathway at INEL	B-21
Table B-7. Site-Specific Parameters and Values Used in the Scoping Evaluation for the Water Pathway at ANLE	B-24
Table B-8. Results of Calculations for the Water Pathway at ANLE	B-26
Table B-9. Site-Specific Parameters and Values Used in the Scoping Evaluation for the Water Pathway at PGDP	B-29
Table B-10. Results of Calculations for the Water Pathway at PGDP	B-31
Table B-11. Site-Specific Parameters and Values Used in the Scoping Evaluation for the Water Pathway at LANL	B-36
Table B-12. Results of Calculations for the Water Pathway at LANL	B-38
Table B-13. Site-Specific Parameters and Values Used in the Scoping Evaluation for the Water Pathway at SNL	B-42
Table B-14. Results of Calculations for the Water Pathway at SNL	B-44
Table B-15. Site-Specific Parameters and Values Used in the Scoping Evaluation for the Water Pathway at WVDP	B-48
Table B-16. Results of Calculations for the Water Pathway at WVDP	B-50
Table B-17. Site-Specific Parameters and Values Used in the Scoping Evaluation for the Water Pathway at FEMP	B-53
Table B-18. Results of Calculations for the Water Pathway at FEMP	B-55
Table B-19. Site-Specific Parameters and Values Used in the Scoping Evaluation for the Water Pathway at PORTS	B-58
Table B-20. Results of Calculations for the Water Pathway at PORTS	B-60
Table B-21. Site-Specific Parameters and Values Used in the Scoping Evaluation for the Water Pathway at SRS	B-64
Table B-22. Results of Calculations for the Water Pathway at SRS	B-65
Table B-23. Site-Specific Parameters and Values Used in the Scoping Evaluation for the Water Pathway at ORR	B-71
Table B-24. Results of Calculations for the Water Pathway at ORR	B-73
Table B-25. Site-Specific Parameters and Values Used in the Scoping Evaluation for the Water Pathway at Pantex	B-76
Table B-26. Results of Calculations for the Water Pathway at Pantex	B-78
Table B-27. Site-Specific Parameters and Values Used in the Scoping Evaluation for the Water Pathway at the Hanford	B-82
Table B-28. Results of Calculations for the Water Pathway at the Hanford Site	B-84

Nomenclature

ANLE	Argonne National Laboratory-East
CERCLA	Comprehensive Environmental Response, Compensation, and Liability Act
CRF	concentration reduction factor
DOE	U.S. Department of Energy
EPA	U.S. Environmental Protection Agency
FEMP	Fernald Environmental Management Project
GMA	Great Miami Aquifer
INEL	Idaho National Engineering Laboratory
LANL	Los Alamos National Laboratory
LLNL	Lawrence Livermore National Laboratory
LLW	low-level waste
MLLW	mixed low-level waste
MWDF	mixed waste disposal facility
NTS	Nevada Test Site
ORR	Oak Ridge Reservation
PGDP	Paducah Gaseous Diffusion Plant
PORTS	Portsmouth Gaseous Diffusion Plant
RGA	Regional Gravel Aquifer
RCRA	Resource Conservation and Recovery Act
RFETS	Rocky Flats Environmental Technology Site
RRR	Risk Reduction Rules
SNL	Sandia National Laboratories
SRS	Savannah River Site
UGMA	Unsaturated Great Miami Aquifer
WVDP	West Valley Demonstration Project

B. SITE EVALUATIONS

The results of the scoping evaluation for hazardous metals for each of 15 DOE sites are reported in this appendix. Also provided in this appendix are brief descriptions of the conceptual models considered in the evaluation of each site as well as the site-specific data used in the calculations. Much of this information is derived from the performance evaluation for radionuclides in treated MLLW (Waters and Gruebel, 1996). Parameter values that are the same for all sites are listed in Chapter 2. The effects on the results of both the major assumptions used in the conceptual model and the assumed values for parameters used in the scoping evaluation are summarized in Chapter 3. An overall discussion of the results for all 15 sites is presented in Chapter 4.

B.1 California: LAWRENCE LIVERMORE NATIONAL LABORATORY SITE 300 (LLNL)

Lawrence Livermore National Laboratory (LLNL) Site 300 is located approximately 24 km (15 mi) southeast of Livermore, California, in the sparsely populated hills of the Diablo Range. Land use surrounding Site 300 is predominantly agricultural. The Carnegie State Vehicular Recreation Area is located south of the site. South and east of the site, a corridor along Corral Hollow Road is designated as an ecological preserve. The nearest urban area is the city of Tracy (population 42,000), approximately 12 km (8 mi) northeast of Site 300.

At the time of the evaluation, site personnel had no plans for on-site disposal of treated MLLW. Site technical personnel proposed two sites as potential locations for the hypothetical disposal facility in the scoping evaluation. Of the two, the selected location within Site 300 was the 829 Site (Figure B-1), primarily because greater amounts of site characterization data were available. This location is near some burn pits for high explosives but is otherwise undeveloped.

B.1.1 Conceptual Model and Site-Specific Data Used in the Scoping Evaluation

The conceptual model for the water pathway at LLNL Site 300 is illustrated in Figure B-2. The site is located on a hilltop at an elevation of approximately 365 m (1200 ft) above mean sea level. The regional water table is located in the Neroly formation at an elevation of approximately 207 m (680 ft) above mean sea level. Groundwater investigations identified the presence of perched groundwater in a monitoring well near the site, with water located at an elevation of 300 m (976 ft) above mean sea level. This perched water zone appears to be the result of human activities at the surface. Because of the transient nature of the perched water zone, the regional aquifer in the Neroly formation was used to establish the maximum hazardous metals concentrations for the water pathway. The site-specific data used in this scoping evaluation are listed in Table B-1.

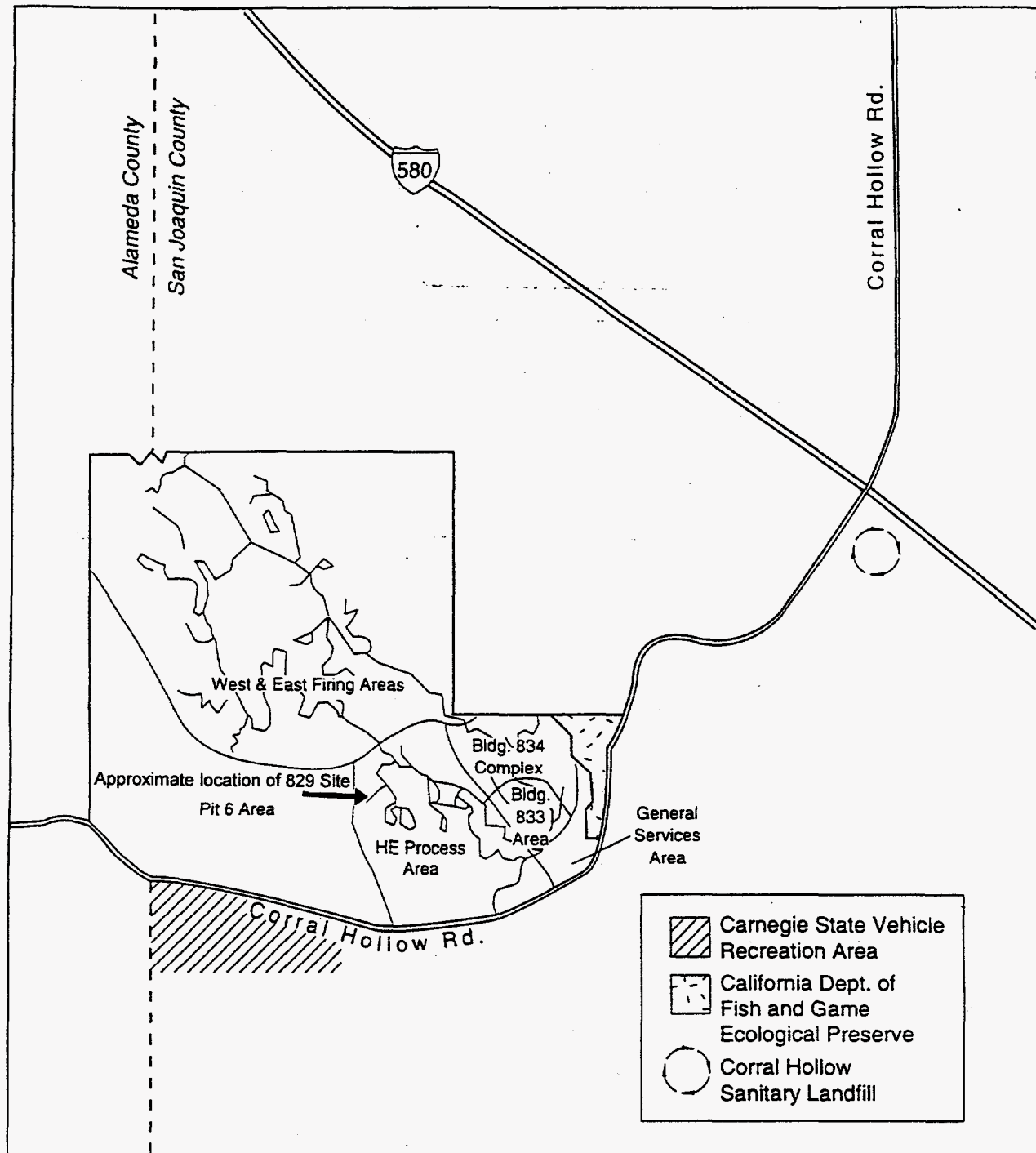

TRI-6622-32-1

Figure B-1. Site map for Lawrence Livermore National Laboratory Site 300.

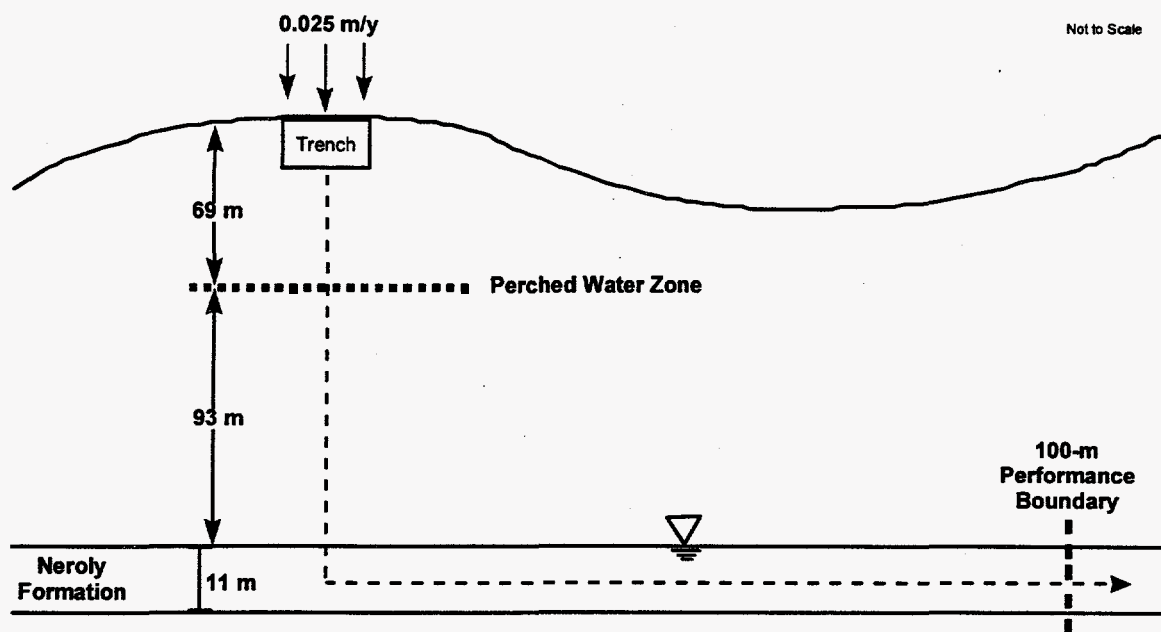

Figure B-2. Conceptual model for the water pathway at LLNL.

Table B-1. Site-Specific Parameters and Values Used in the Scoping Evaluation for the Water Pathway at LLNL (generic values are listed in Chapter 2)

Parameter	Value	Data Type	Comments
UNSATURATED ZONE			
Natural recharge through local soils, i	0.025 m/y	A	Raber and Carpenter, 1983
Annual rate of water flowing through intact disposal facility, q_f	0.025 m/y	A	Natural recharge is less than that assumed for the performance of the engineered barriers
Moisture content, θ_w	0.17	A	Madrid, 1992
Bulk density, ρ_b	2.0 g/cm ³	C	Dry bulk density of quartz at 25% porosity
Distribution coefficients for geologic media, K_d	Various		Default values; see Table 2-5
Thickness between trench and saturated zone, l_v	153.2 m	A	Monitoring wells W-829-06 and W-829-08; Table 13-17 in Webster-Scholten, 1994
SATURATED ZONE			
Porosity, n	0.25	C	Ferry, 1994
Bulk density, ρ_b	2.0 g/cm ³	C	Dry bulk density of quartz at 25% porosity
Distribution coefficients for geologic media, K_d	Various		Default values; see Table 2-5
Mixing depth, d_m	11 m		Calculated by Sandia National Laboratories using PAGAN (Chu et al., 1991)
Darcy velocity, q_{gw}	9.9 m/y	B	Based on hydraulic gradient of 0.017 (Carpenter, 1994) [based on dip of formation] and hydraulic conductivity of 1.85×10^{-3} cm/s (Webster-Scholten, 1994; Carpenter, 1994)

* A=site measurement; B=result of site numerical analysis; C=literature value selected by site technical staff

Although engineered barriers were assumed to remain intact for 100 y (30 y of detention plus 70 y limited by the RCRA cover system), vertical flow through the facility immediately after disposal was assumed to be the average recharge through local soils, 0.025 m/y, because it is less than the assumed rate of water moving through the facility's intact RCRA cap (0.03 m/y [see Section 2.2.2]). Engineered barriers were assumed to fail instantaneously at 100 y, and the rate of water flowing through the facility after that time was assumed to remain the same as the average recharge through local soils, 0.025 m/y.

As leachate entered the saturated zone, it was assumed to mix with uncontaminated groundwater, forming a plume with a shape controlled by aquifer and contaminant properties. Complete mixing within the aquifer was assumed to occur directly below the facility. The contaminant mixing depth was an estimated value of plume thickness due to vertical dispersion at the 100-m performance boundary (see Section 2.3.2).

B.1.2 Results of the Scoping Evaluation

Application of the methodology outlined in Chapter 2 produced the results shown in Table B-2. The table shows a maximum concentration in treated MLLW (C_{Waste}) and travel time to the performance boundary for each hazardous metal as well as the values used in calculating these results.

In the analysis, the attenuation that occurred between the waste in the disposal facility and the performance boundary was represented by the product of the source concentration reduction factors (CRFs) for the source (CRF_{Source}) and for environmental transport (CRF_{Water}). For the 8 hazardous metals listed in Table B-2, this value ranged from about 280 to 24,000.

The travel time of water from the disposal facility to the 100-m performance boundary was calculated as a basis for comparison with the retarded travel time of the hazardous metals. For LLNL, water travel time from the land surface to the performance boundary (i.e., without consideration of a disposal facility) was estimated at about 1100 y. Of that time, travel time in the saturated zone was about 2.5 y.

Based on the results of the scoping analysis, the following observations can be made about disposal at LLNL of hazardous metals contained in treated MLLW:

- Calculated maximum leachate concentrations for 6 of the 8 hazardous metals are greater than the solubilities of the associated metals. These metals are considered to have unlimited values for C_{Waste} .
- Of the two hazardous metals that are not solubility limited, selenium has the smallest value for C_{Waste} (1 mg/kg) and chromium the largest (50 mg/kg).
- For selenium and chromium, the two metals that are not solubility limited, calculated travel times to the performance boundary are 99,000 y and 860,000 y, respectively. Travel time through the unsaturated zone accounts for almost all of the total subsurface travel time.

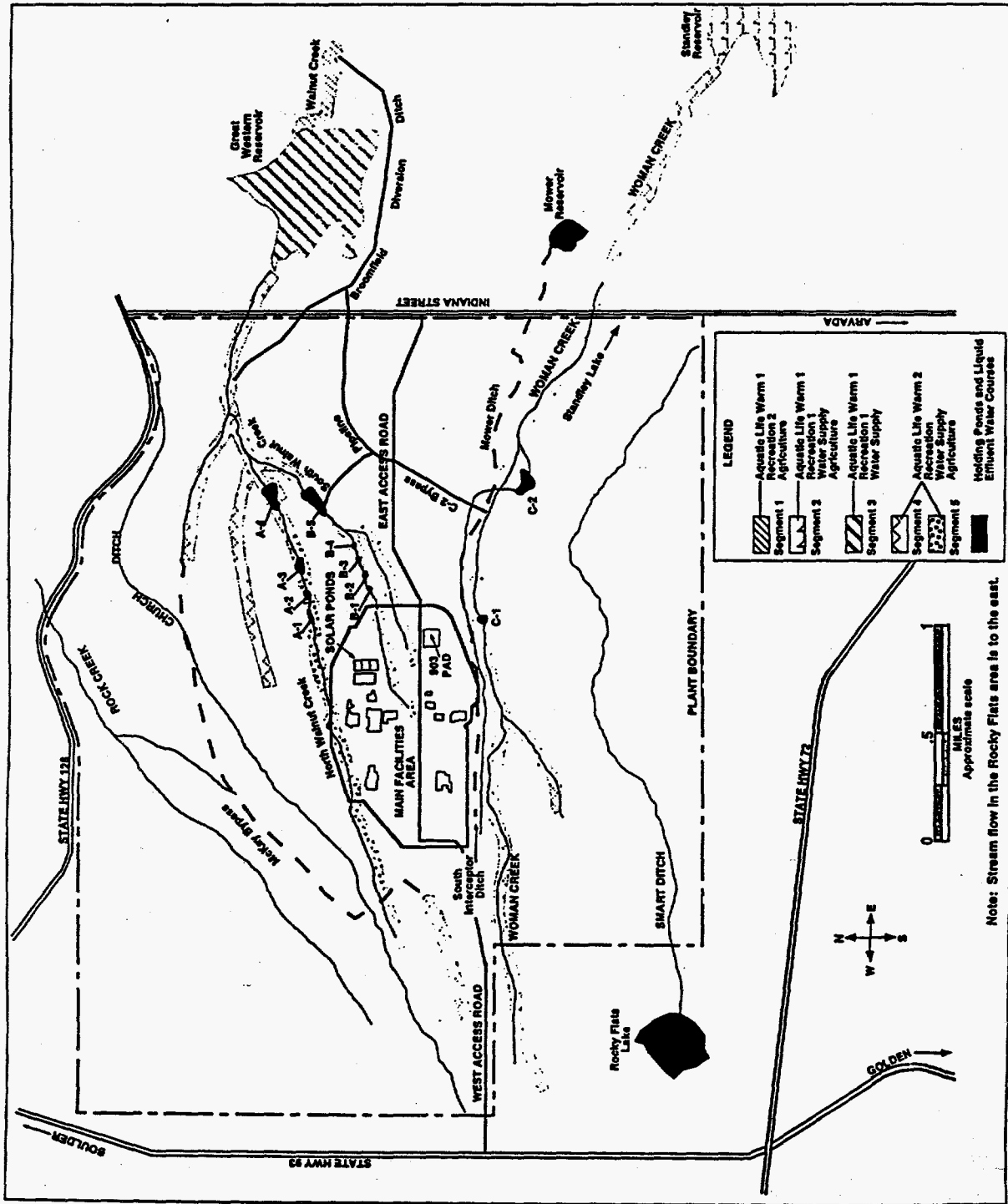

Figure B-3. Site map for Rocky Flats Environmental Technology Site (EG&G Rocky Flats, Inc., 1993, Figure 2.3.3-2).

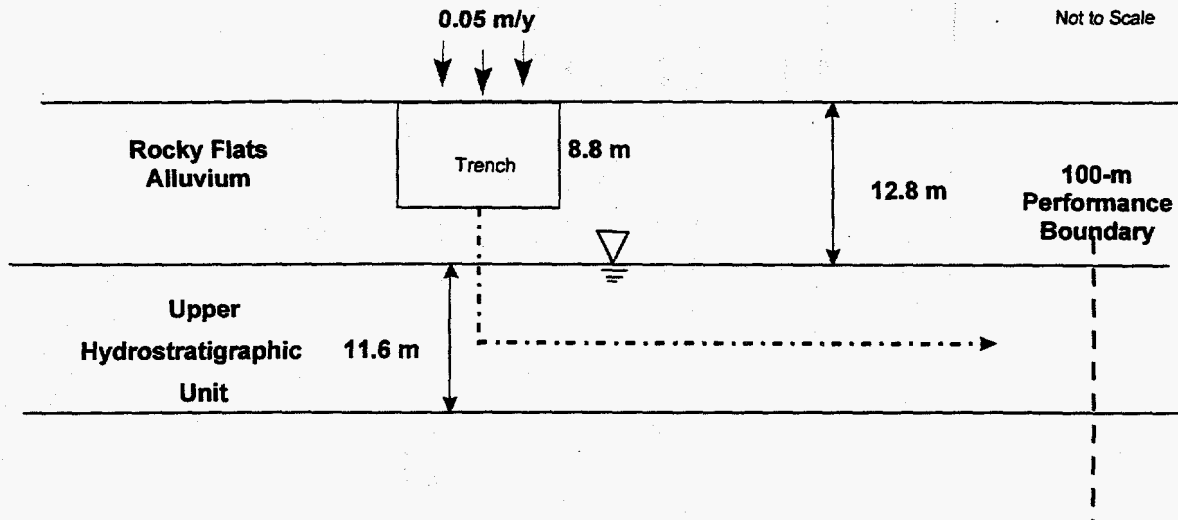

Figure B-4. Conceptual model for the water pathway at RFETS.

Table B-3. Site-Specific Parameters and Values Used in the Scoping Evaluation for the Water Pathway at RFETS (generic values are listed in Chapter 2)

Parameter	Value	Data Type*	Comments
UNSATURATED ZONE			
Natural recharge through local soils, i	0.05 m/y	B	EG&G, 1993
Moisture content, θ_w	0.12	B	ASI, 1993
Bulk density, ρ_b	1.34 g/cm ³	C	Fedors & Warner, 1993
Distribution coefficients for geologic media, K_d	Various		Default values; see Table 2-5
Thickness between trench and saturated zone, l_v	4 m	A	EG&G, 1995
SATURATED ZONE			
Porosity, n	0.1	C	Hurr, 1976
Bulk density, ρ_b	1.34 g/cm ³	C	Fedors & Warner, 1993
Distribution coefficients for geologic media, K_d	Various		Default values; see Table 2-5
Mixing depth, d_m	11.6 m		Calculated by Sandia National Laboratories using PAGAN (Chu et al., 1991)
Darcy velocity, q_{gw}	0.59 m/y	B	Calculated from data in EG&G, 1995

* A=site measurement; B=result of site numerical analysis; C=literature value selected by the site

B.2.2 Results of the Scoping Evaluation

Application of the methodology outlined in Chapter 2 produced the results shown in Table B-4. The table shows a maximum concentration in treated MLLW (C_{Waste}) and travel time to the performance boundary for each hazardous metal as well as the values used in calculating these results.

In the analysis, the attenuation that occurred between the waste in the disposal facility and the performance boundary was represented by the product of the CRF_{Source} and the CRF_{Water} . For the 8 hazardous metals listed in Table B-4, this value ranged from about 12 to 1000.

The travel time of water from the disposal facility to the 100-m performance boundary was calculated as a basis for comparison with the retarded travel time of the hazardous metals. For RFETS, water travel time from the land surface to the performance boundary (i.e., without consideration of a disposal facility) was estimated at about 48 y. Of that time, travel time in the saturated zone was about 17 y.

Based on the results of the scoping analysis, the following observations can be made about disposal at RFETS of hazardous metals contained in treated MLLW:

- The calculated maximum leachate concentration for one of the 8 hazardous metals is greater than the solubility of the associated metal. This metal, barium, is considered to have an unlimited value for C_{Waste} .
- Values for C_{Waste} for 7 hazardous metals that are not solubility limited range over 3 orders of magnitude. The smallest values for C_{Waste} are for selenium and mercury, and the largest is for lead.
- Among the 7 hazardous metals that are not solubility limited, travel times to the performance boundary range from about 2000 y to 89,000 y. The shortest travel time is for arsenic, and the longest is for lead. Travel time through the unsaturated zone accounts for about one-third of the total subsurface travel time.

Table B-4. Results of Calculations for the Water Pathway at RFETS

Hazardous Metal	Maximum Allowable Concentration in Groundwater, C_{Water}	CRF_{Source}	CRF_{Water}	Maximum Leachate Concentration, C_L	Solubility ^a	Maximum Concentration in Treated MLLW, C_{Waste}^b	Travel Time to Performance Boundary		
							Unsaturated (Vadose) Zone	Saturated Zone	Total
							(y)	(y)	(y)
	(mg/L)	(dimensionless)	(dimensionless)	(mg/L)	(mg/L)	(mg/kg)			
Arsenic (As)	0.05	27	3.7	1.9E-01	3.0E-01	2E+00	6.2E+02	1.4E+03	2.0E+03
Barium (Ba)	1	27	3.7	3.7E+00	1.8E+00	NL	5.1E+04	1.1E+05	1.6E+05
Cadmium (Cd)	0.01	270	3.7	3.7E-02	8.0E-01	4E+00	8.2E+03	1.8E+04	2.6E+04
Chromium (Cr)	0.05	27	3.7	1.9E-01	2.1E+04	2E+00	7.1E+03	1.6E+04	2.3E+04
Lead (Pb)	0.05	270	3.7	1.9E-01	8.0E-01	2E+01	2.8E+04	6.1E+04	8.9E+04
Mercury (Hg)	0.002	27	3.7	7.5E-03	9.0E-03	9E-02	1.0E+04	2.3E+04	3.3E+04
Selenium (Se)	0.01	3.2	3.7	3.7E-02	2.8E+06	5E-02	8.2E+02	1.8E+03	2.7E+03
Silver (Ag)	0.05	3.2	3.7	1.9E-01	7.0E-01	2E-01	9.2E+03	2.0E+04	3.0E+04

a The solubility of the metal in a selected hazardous metal compound in groundwater (see Section 2.3.3)

b NL means "no limit": the maximum leachate concentration is greater than the solubility of the metal

B.3 Idaho: IDAHO NATIONAL ENGINEERING LABORATORY (INEL)

The Idaho National Engineering Laboratory (INEL) is located along the northwestern edge of the Eastern Snake River Plain in southeastern Idaho, near the city of Idaho Falls. The INEL site lies at the base of three mountain ranges—the Lost River range, the Lemhi range, and the Bitterroot-Centennial range—and covers 2315 km² (895 mi²) of semiarid shrub steppe. Most of the land at INEL withdrawn from public domain for use by DOE is undeveloped. The INEL site is located within Resource Areas administered by the Bureau of Land Management. The largest town near the INEL boundary is Arco with a population of 1100 residents, located 11 km (7 mi) to the west.

At the time of the evaluation, personnel at INEL had no specific plans for on-site disposal of treated MLLW. Available land for additional expansion of activities at the Radioactive Waste Management Complex is limited. However, site technical staff had begun to identify possible suitable locations for disposal of treated MLLW. The hypothetical disposal facility evaluated in this scoping evaluation is located in the north-central portion of INEL in the general vicinity of and just south of the Test Area North (Figure B-5).

B.3.1 Conceptual Model and Site-Specific Data Used in the Scoping Evaluation

The conceptual model for the water pathway at INEL is illustrated in Figure B-6. An unsaturated zone thickness of 50 m (160 ft) was assumed. The unsaturated zone was modeled as a single unit of sedimentary deposits, uninterrupted by basalt interbeds or other significant features. The entire Eastern Snake River Plain is underlain by the Snake River Plain Aquifer. The aquifer is thick with rapid water flow rates—average horizontal pore water velocities are estimated at several hundred meters per year. Because of this rate of groundwater flow, the unsaturated zone provides primary attenuation of contaminant releases to the subsurface. A 12-m mixing depth was assumed for the aquifer, based upon the average screen depth for drinking water wells drilled into the aquifer. The site-specific data used in the scoping evaluation are listed in Table B-5.

Because engineered barriers were assumed to remain intact for 100 y (30 y of detention plus 70 y limited by the RCRA cover system), vertical flow through the facility immediately after disposal was assumed to be 0.03 m/y, which is less than the average recharge through local soils (see Section 2.2.2). Engineered barriers were assumed to fail instantaneously at 100 y, so that the rate of water flowing through the facility after that time was assumed to be the average recharge through local soils, 0.07 m/y.

As leachate entered the saturated zone, it was assumed to mix with uncontaminated groundwater, forming a plume with a shape controlled by aquifer and contaminant properties. Complete mixing within the aquifer was assumed to occur directly below the facility. The contaminant mixing depth of 12 m was an estimated value based on the well screen depth used in INEL's performance assessment (see Section 2.3.2).

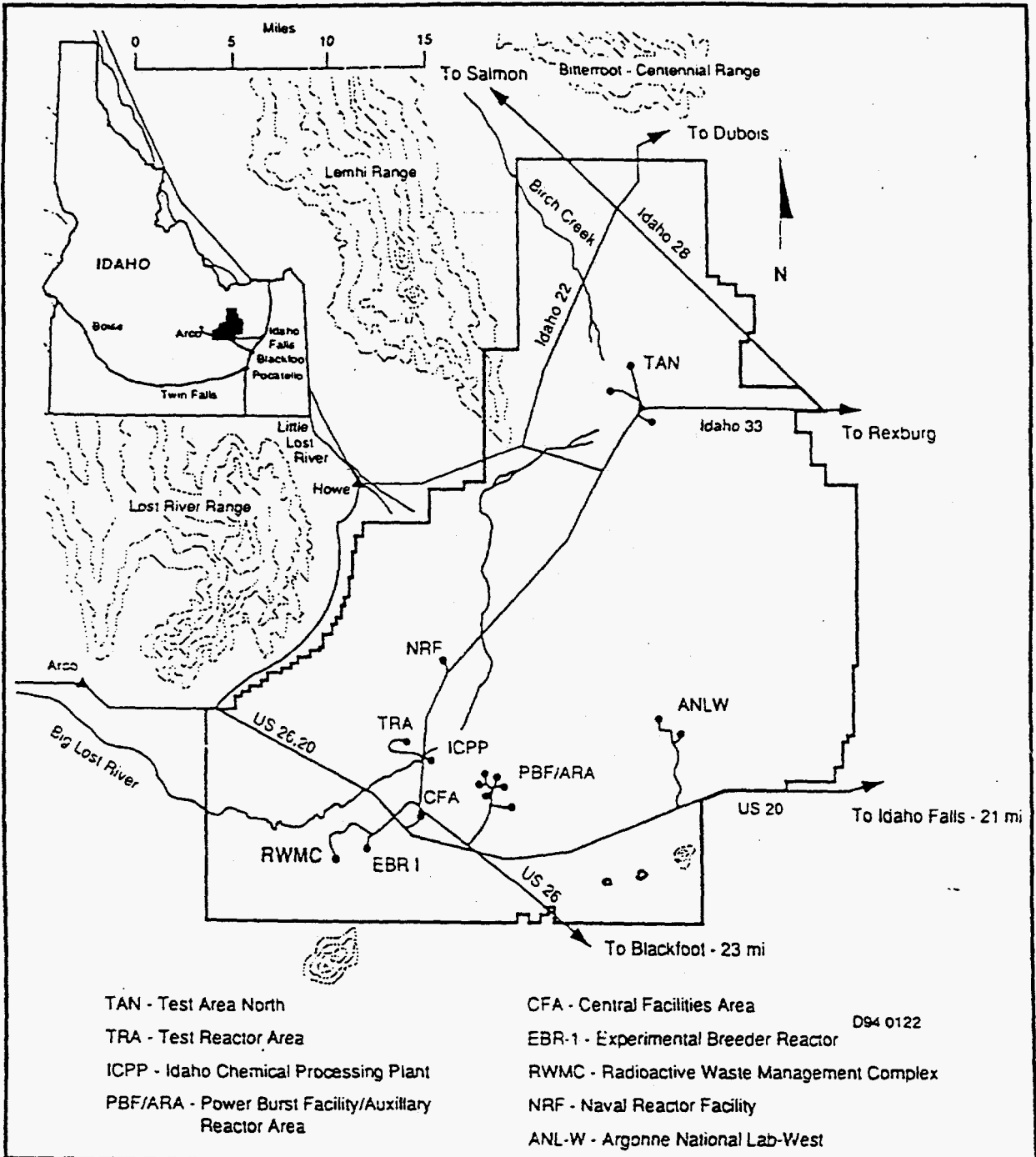

Figure B-5. Site map for the Idaho National Engineering Laboratory.

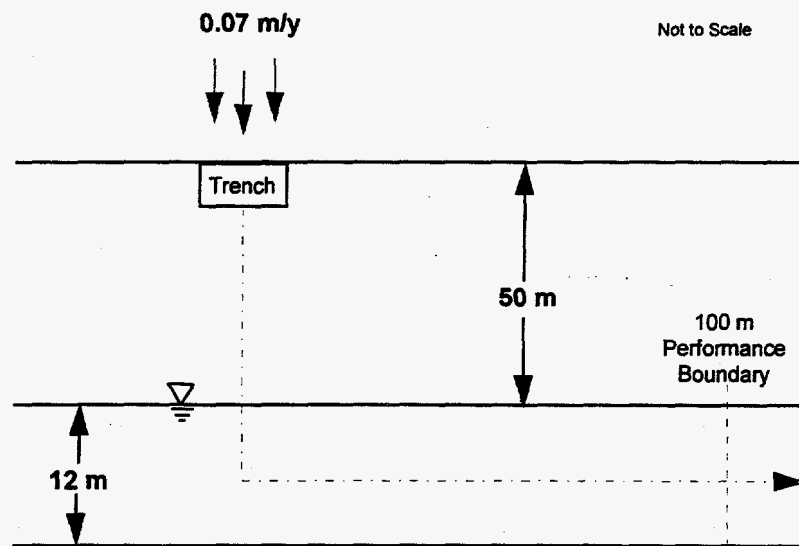

Figure B-6. Conceptual model for the water pathway at INEL.

Table B-5. Site-Specific Parameters and Values Used in the Scoping Evaluation for the Water Pathway at INEL (generic values are listed in Chapter 2)

Parameter	Value	Data Type*	Comments
UNSATURATED ZONE			
Natural recharge through local soils, i	0.07 m/y	A	Rood et al., 1994
Moisture content, θ_w	0.17	A	Rood et al., 1994
Bulk density, ρ_b	1.5 g/cm ³	A	Rood et al., 1994
Distribution coefficients for geologic media, K_d			
As, Cd, Cr, Hg, Se, Ag	Various		Default values; see Table 2-5
Ba	60 mL/g	A	Majeras et al., 1994
Pb	100 mL/g	A	Case et al., 1990
Thickness between trench and saturated zone, l_v	41.2 m	A	Cumulative unsaturated sediment thickness is 50 m (Taylor, 1994) and trench facility bottom is 9 m below ground surface
SATURATED ZONE			
Porosity, n	0.1	A	Rood et al., 1994
Bulk density, ρ_b	1.9 g/cm ³	A	Rood et al., 1994
Distribution coefficients for geologic media, K_d			
As, Cd, Cr, Hg, Se, Ag	Various		Default values; see Table 2-5
Ba	60 mL/g	A	Majeras et al., 1994
Pb	10 mL/g	A	Case et al., 1990
Mixing depth, d_m	12 m	B	Well screen depth used in INEL's performance assessment; it is less than the predicted mixing depth and is therefore conservative. (Rood et al., 1994)
Darcy velocity, q_{gw}	56 m/y	A	Rood et al., 1994

* A=site measurement; B=result of site numerical analysis; C=literature value selected by the site

B.3.2 Results of the Scoping Evaluation

Application of the methodology outlined in Chapter 2 produced the results shown in Table B-6. The table shows a maximum concentration in treated MLLW (C_{Waste}) and travel time to the performance boundary for each hazardous metal as well as the values used in calculating these results.

In the analysis, the attenuation that occurred between the waste in the disposal facility and the performance boundary was represented by the product of the CRF_{Source} and the CRF_{Water} . For the 8 hazardous metals listed in Table B-6, the total CRF ranged from about 600 to 51,000.

The travel time of water from the disposal facility to the 100-m performance boundary was calculated as a basis for comparison with the retarded travel time of the hazardous metals. For INEL, water travel time from the land surface to the performance boundary (i.e., without consideration of a disposal facility) was estimated at about 120 y. Of that time, travel time in the saturated zone was less than one year.

Based on the results of the scoping analysis, the following observations can be made about disposal at INEL of hazardous metals contained in treated MLLW:

- Calculated maximum leachate concentrations for 6 of the 8 hazardous metals are greater than the solubilities of the associated metals. These metals are considered to have unlimited values for C_{Waste} .
- Of the two hazardous metals that are not solubility limited, selenium has the smallest value for C_{Waste} (3 mg/kg) and chromium the largest (100 mg/kg).
- For selenium and chromium, the two metals that are not solubility limited, calculated travel times to the performance boundary are 7200 y and 62,000 y, respectively. Travel time through the unsaturated zone accounts for almost all of the total subsurface travel time.

Table B-6. Results of Calculations for the Water Pathway at INEL

Hazardous Metal	Maximum Allowable Concentration in Groundwater, C_{Water}	CRF_{Source}	CRF_{Water}	Maximum Leachate Concentration, C_L	Solubility ^a	Maximum Concentration in Treated MLLW, C_{Waste}^b	Travel Time to Performance Boundary		
							Unsaturated (Vadose) Zone	Saturated Zone	Total
							(y)	(y)	(y)
Arsenic (As)	0.05	27	190	9.7E+00	3.0E-01	NL	5.4E+03	2.1E+01	5.4E+03
Barium (Ba)	1	27	190	1.9E+02	1.8E+00	NL	5.3E+04	2.0E+02	5.3E+04
Cadmium (Cd)	0.01	270	190	1.9E+00	8.0E-01	NL	7.0E+04	2.7E+02	7.1E+04
Chromium (Cr)	0.05	27	190	9.7E+00	2.1E+04	1E+02	6.2E+04	2.4E+02	6.2E+04
Lead (Pb)	0.05	270	190	9.7E+00	8.0E-01	NL	8.8E+04	3.4E+01	8.8E+04
Mercury (Hg)	0.002	27	190	3.9E-01	9.0E-03	NL	8.8E+04	3.4E+02	8.8E+04
Selenium (Se)	0.01	3.2	190	1.9E+00	2.8E+06	3E+00	7.1E+03	2.7E+01	7.2E+03
Silver (Ag)	0.05	3.2	190	9.7E+00	7.0E-01	NL	7.9E+04	3.1E+02	7.9E+04

a The solubility of the metal in a selected hazardous metal compound in groundwater (see Section 2.3.3)

b NL means "no limit": the maximum leachate concentration is greater than the solubility of the metal

B.4 Illinois: ARGONNE NATIONAL LABORATORY—EAST (ANLE)

Argonne National Laboratory—East (ANLE) is located in DuPage County, Illinois, approximately 35 km (22 mi) southwest of downtown Chicago and 40 km (25 mi) west of Lake Michigan. The site is north of the Des Plaines River Valley, south of Interstate Highway 55, and west of Illinois Highway 83. Major features of the region include both the Des Plaines River channel, which contains the river and the Chicago Sanitary and Ship Canal, and Lake Michigan.

At the time of the evaluation, site personnel were not planning for on-site disposal of treated MLLW. Technical staff at ANLE indicated that a possible location to be considered in the scoping evaluation would be in the western or northwestern portion of the site near the 800 Area (Figure B-7). Selection of this location for the hypothetical disposal facility did not take into account any possible future use of the area based on facility planning.

B.4.1 Conceptual Model and Site-Specific Data Used in the Scoping Evaluation

The conceptual model for the water pathway at ANLE is illustrated in Figure B-8. The conceptual model incorporated vertical movement of hazardous metals through the unsaturated zone (glacial till) to the saturated zone (fractured dolomite aquifer) and subsequent lateral transport 100 m through the saturated zone to the performance boundary.

The unsaturated zone, consisting of surficial deposits and the Wadsworth Till and Lemont Drift, was simplified to one unit. The surficial deposits are relatively thin and variable and do not contribute significantly to the transport model. The glacial till is highly variable in composition, potentially consisting of zones ranging from clayey silt to sand and gravel. Sand lenses in the Wadsworth Till and Lemont Drift were not considered as potential aquifers because data indicated extreme seasonal fluctuations, questionable lateral flow, and probable absence in the 800 Area. In the model, the saturated zone in the upper fractured dolomite of the Silurian-age aquifer was assumed to be the shallowest viable source of drinking water. The site-specific data used in this scoping evaluation are listed in Table B-7.

The disposal facility design used in this scoping evaluation was a trench. However, facilities having additional engineered features are used at some sites in the humid region of the country for disposal of low-level waste. For example, a tumulus design is used at ORR (ORNL, 1994), and a vault design is used at SRS (MMES et al., 1994). These types of facilities are designed to minimize the contact of infiltrating water with the waste and may result in higher maximum concentrations for hazardous metals in treated MLLW.

In this scoping evaluation, engineered barriers for the trench design were assumed to remain intact for 100 y (30 y of detention plus 70 y limited by the RCRA cover system). Vertical flow through the facility immediately after disposal was assumed to be 0.03 m/y, which is less than the average recharge through local soils (see Section 2.2.2). Engineered barriers were assumed to fail instantaneously at 100 y, so that the rate of water flowing through the facility after that time was assumed to be the average recharge through local soils, 0.102 m/y.

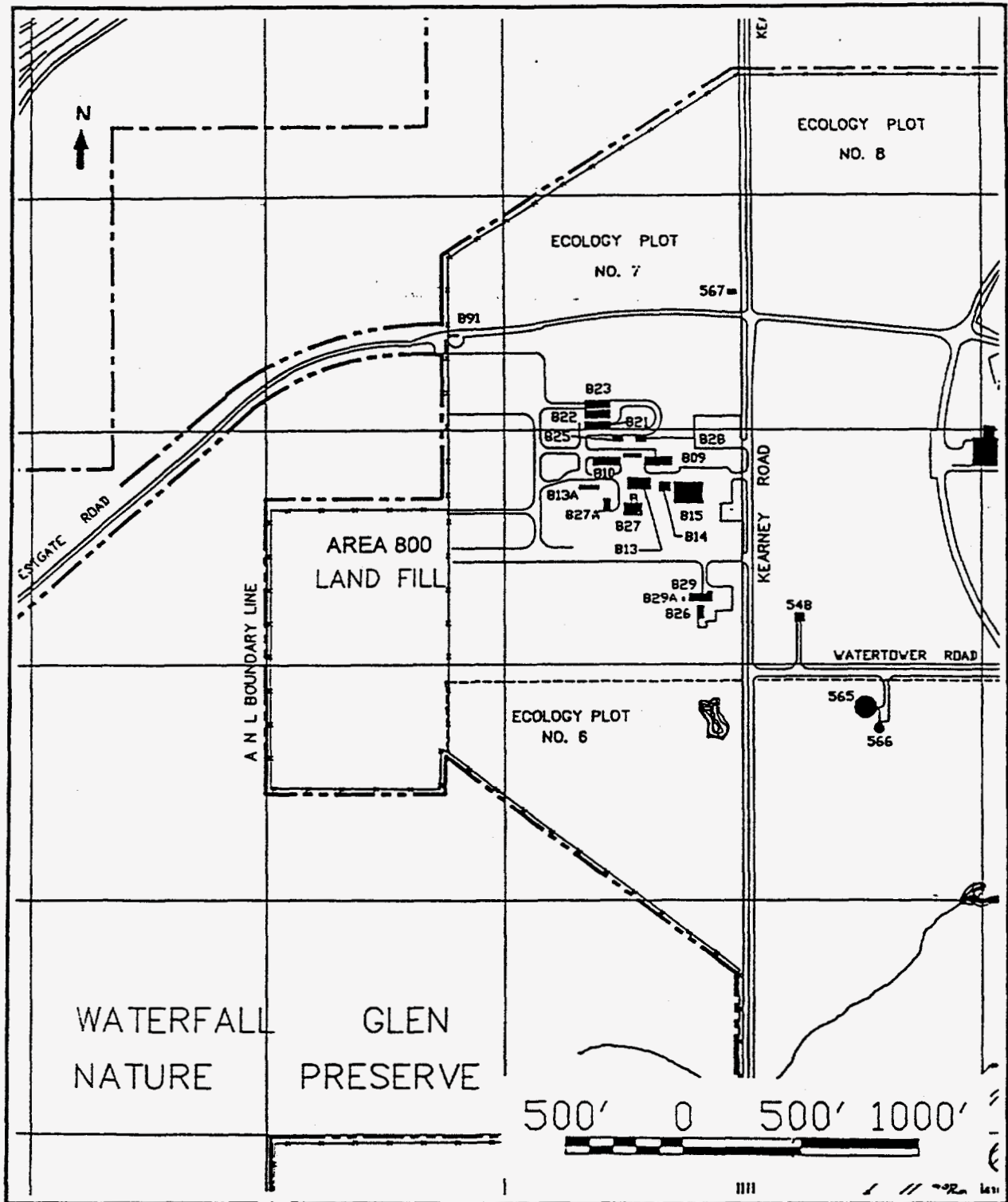

Figure B-7. General location near the 800 Area Landfill for the generic MLLW disposal facility at ANLE.

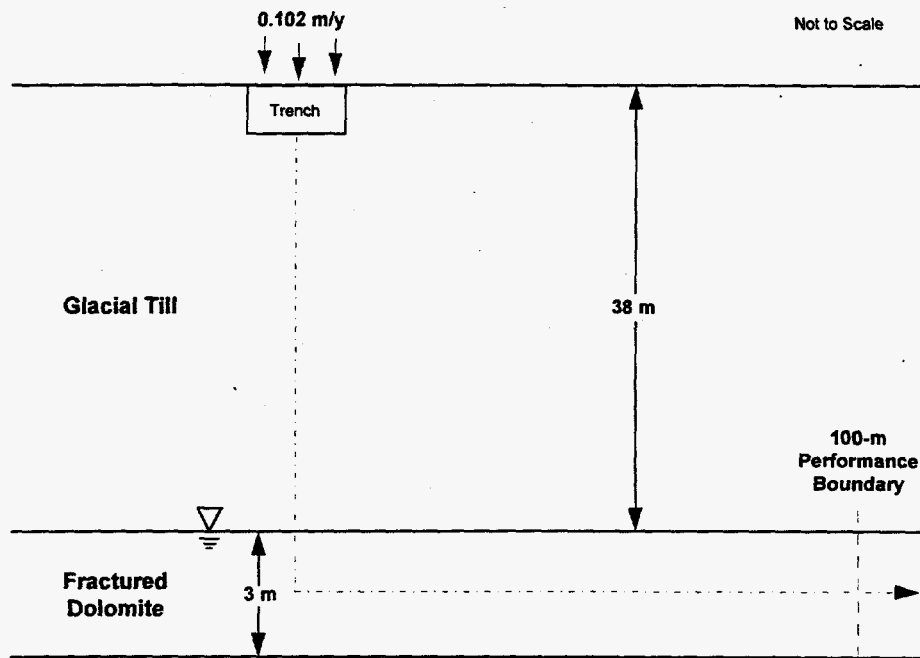

Figure B-8. Conceptual model for the water pathway at ANLE.

Table B-7. Site-Specific Parameters and Values Used in the Scoping Evaluation for the Water Pathway at ANLE (generic values are listed in Chapter 2)

Parameter	Value	Data Type*	Comments
UNSATURATED ZONE			
Natural recharge through local soils, i	0.102 m/y	A	Knowles et al., 1963, p. 21
Moisture content, θ_w	0.16	C	Calculated based on a seepage velocity of 0.1 in./day and coefficient of permeability of 0.01 gal/day per ft ² (Knowles et al., 1963, p. 20)
Bulk density, ρ_b	1.8 g/cm ³	A	Unpublished analytical results from 317/319 Area and 800 Area Landfill
Distribution coefficients for geologic media, K_d	Various		Default values; see Table 2-5
Thickness between trench and saturated zone, l_v	29.2 m	A	Estimate based on well log depths to bedrock (ANLE, 1993, Table 2.3); also unpublished preliminary mapping of thickness of glacial till (isopach)
SATURATED ZONE			
Porosity, n	0.03	C	Krynine and Judd, 1957, p. 49
Bulk density, ρ_b	2.7 g/cm ³	C	Krynine and Judd, 1957, p. 49
Distribution coefficients for geologic media, K_d	Various		Default values; see Table 2-5
Mixing depth, d_m	3 m	A	Well logs indicating fracturing in upper 10 -12 ft (3-3.5 m) (G&M, 1995); fractured flow zone (Golchert, 1994, p. 29)
Darcy velocity, q_{gw}	6 m/y	B	Product of hydraulic conductivity and hydraulic gradient

* A=site measurement; B=result of site numerical analysis; C=literature value selected by the site

As leachate entered the saturated zone, it was assumed to mix with uncontaminated groundwater, forming a plume with a shape controlled by aquifer and contaminant properties. Complete mixing within the aquifer was assumed to occur directly below the facility. The contaminant mixing depth of 3 m was an estimated value based on the assumption that complete mixing occurs across the aquifer's entire depth (see Section 2.3.2).

B.4.2 Results of the Scoping Evaluation

Application of the methodology outlined in Chapter 2 produced the results shown in Table B-8. The table shows a maximum concentration in treated MLLW (C_{Waste}) and travel time to the performance boundary for each hazardous metal as well as the values used in calculating these results.

In the analysis, the attenuation that occurred between the waste in the disposal facility and the performance boundary was represented by the product of the CRF_{Source} and the CRF_{Water} . For the 8 hazardous metals listed in Table B-8, the total CRF ranged from about 14 to 1200.

The travel time of water from the disposal facility to the 100-m performance boundary was calculated as a basis for comparison with the retarded travel time of the hazardous metals. For ANLE, water travel time from the land surface to the performance boundary (i.e., without consideration of a disposal facility) was estimated at about 110 y. Of that time, travel time in the saturated zone was less than one year.

Based on the results of the scoping analysis, the following observations can be made about disposal at ANLE of hazardous metals contained in treated MLLW:

- Calculated maximum leachate concentrations for 2 of the 8 hazardous metals (barium and mercury) are greater than the solubilities of the metals. These metals are considered to have unlimited values for C_{Waste} .
- Values for C_{Waste} for the 6 hazardous metals that are not solubility limited range over 3 orders of magnitude. The smallest value for C_{Waste} is for selenium, and the largest is for lead.
- Among the 6 hazardous metals that are not solubility limited, travel times to the performance boundary range from about 3400 y to 150,000 y. The shortest travel time is for arsenic and the longest is for lead. Travel time through the unsaturated zone accounts for almost all of the total subsurface travel time.

Table B-8. Results of Calculations for the Water Pathway at ANLE

Hazardous Metal	Maximum Allowable Concentration in Groundwater, C_{Water}	CRF_{Source}	CRF_{Water}	Maximum Leachate Concentration, C_L	Solubility ^a	Maximum Concentration in Treated MLLW, C_{Waste}^b	Travel Time to Performance Boundary		
							Unsaturated (Vadose) Zone	Saturated Zone	Total
	(mg/L)	(dimensionless)	(dimensionless)	(mg/L)	(mg/L)	(mg/kg)	(y)	(y)	(y)
Arsenic (As)	0.05	27	4.5	2.3E-01	3.0E-01	3E+00	3.1E+03	2.7E+02	3.4E+03
Barium (Ba)	1	27	4.5	4.5E+00	1.8E+00	NL	2.6E+05	2.3E+04	2.8E+05
Cadmium (Cd)	0.01	270	4.5	4.5E-02	8.0E-01	5E+00	4.1E+04	3.6E+03	4.5E+04
Chromium (Cr)	0.05	27	4.5	2.3E-01	2.1E+04	3E+00	3.6E+04	3.2E+03	3.9E+04
Lead (Pb)	0.05	270	4.5	2.3E-01	8.0E-01	3E+01	1.4E+05	1.2E+04	1.5E+05
Mercury (Hg)	0.002	27	4.5	9.1E-03	9.0E-03	NL	5.1E+04	4.5E+03	5.6E+04
Selenium (Se)	0.01	3.2	4.5	4.5E-02	2.8E+06	6E-02	4.1E+03	3.6E+02	4.5E+03
Silver (Ag)	0.05	3.2	4.5	2.3E-01	7.0E-01	3E-01	4.6E+04	4.1E+03	5.0E+04

a The solubility of the metal in a selected hazardous metal compound in groundwater (see Section 2.3.3)

b NL means "no limit": the maximum leachate concentration is greater than the solubility of the metal

B.5 Kentucky: PADUCAH GASEOUS DIFFUSION PLANT (PGDP)

The Paducah Gaseous Diffusion Plant (PGDP) is located in the western portion of the Ohio River drainage basin, in extreme western Kentucky. The plant resides within a 304-ha (750-ac) fenced area on a 1386-ha (3423-ac) federal reservation, about 14 km (9 mi) west of the city of Paducah, Kentucky, and 5 km (3 mi) south of the Ohio River. The plant is adjacent to the West Kentucky Wildlife Management Area on the west and south, and adjacent to the Tennessee Valley Authority Shawnee Plant on the north. The nominal elevation in the main plant area is 116 m (380 ft) above the mean sea level, 22 m (73 ft) above the average pool level of the Ohio River near PGDP.

At the time of the scoping evaluation, personnel at the PGDP had no plans for on-site disposal of treated MLLW. Technical staff identified three primary areas as possible treated MLLW disposal sites (Figure B-9). All of these locations are immediately west of the fenced area. The site labeled "nw" on Figure B-9 was chosen for the evaluation because it would provide the greatest depth to groundwater.

B.5.1 Conceptual Model and Site-Specific Data Used in the Scoping Evaluation

The conceptual model for the water pathway at PGDP is illustrated in Figure B-10. The groundwater at the evaluated site moves downward through the unsaturated zone and the semi-confining upper continental deposits to the Regional Gravel Aquifer (RGA) and is transported in the RGA northward to the performance boundary. Because the unsaturated zone is thin (1.5 m), the disposal facility is designed as a mounded trench so that there is at least 1 m of unsaturated zone below the trench. To simplify the analysis, the thickness of the semi-confining layer (14 m) was added to the thickness of the unsaturated zone below the trench (1 m) to make a zone of vertical transport that is 15 m thick. These two zones were assigned the same hydrogeological properties. The saturated zone consists of the RGA alone as a zone of horizontal transport. The site-specific data used in the scoping evaluation are listed in Table B-9.

The disposal facility design used in this scoping evaluation was a trench. However, facilities having additional engineered features are used at some sites in the humid region of the country for disposal of low-level waste. For example, a tumulus design is used at ORR (ORNL, 1994), and a vault design is used at SRS (MMES et al., 1994). These types of facilities are designed to minimize the contact of infiltrating water with the waste and may result in higher maximum concentrations for hazardous metals in treated MLLW.

In this scoping evaluation, engineered barriers for the trench design were assumed to remain intact for 100 y (30 y of detention plus 70 y limited by the RCRA cover system). Vertical flow through the facility immediately after disposal was assumed to be 0.03 m/y, which is less than the average recharge through local soils (see Section 2.2.2). Engineered barriers were assumed to fail instantaneously at 100 y, so that the rate of water flowing through the facility after that time was assumed to be the average recharge through local soils, 0.12 m/y.

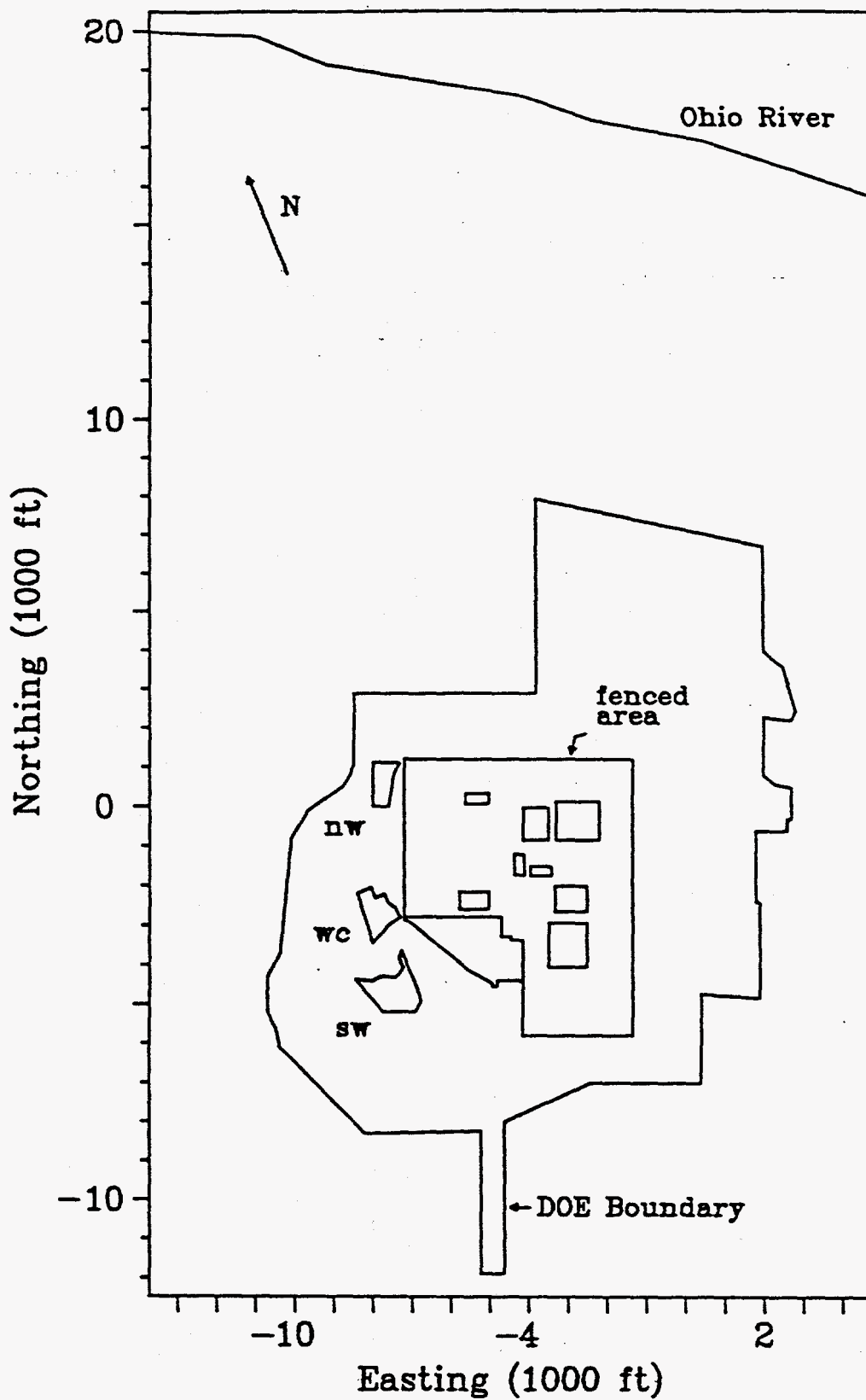

Figure B-9. Possible MLLW disposal sites identified by the PGDP technical staff.

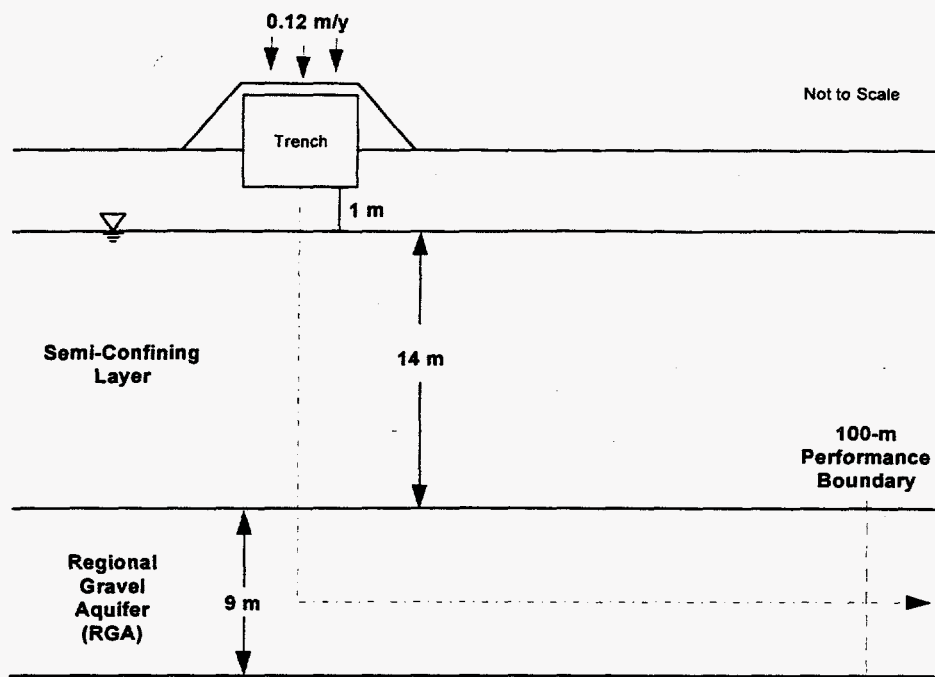

Figure B-10. Conceptual model for the water pathway at PGDP.

Table B-9. Site-Specific Parameters and Values Used in the Scoping Evaluation for the Water Pathway at PGDP (generic values are listed in Chapter 2)

Parameter	Value	Data Type*	Comments
UNSATURATED ZONE			
Natural recharge through local soils, i	0.12 m/y	A	GeoTrans, Inc. (1990)
Moisture content, θ_w	0.2	A	Shaia (1995)
Bulk density, ρ_b	1.7 g/cm ³	A	Shaia (1995)
Distribution coefficients for geologic media, K_d	Various		Default values; see Table 2-5
Thickness between trench and semi-confining layer	1 m	A	Cumulative unsaturated sediment thickness is 1.5 m (Davis, 1995a); trench is 9 m in depth, with 8.5 m above ground
SEMI-CONFINING LAYER			
Natural recharge through local soils, i	0.12 m/y	A	GeoTrans, Inc. (1990)
Moisture content, θ_w	0.2	A	Shaia (1995)
Bulk density, ρ_b	1.7 g/cm ³	A	Shaia (1995)
Distribution coefficients for geologic media, K_d	Various		Default values; see Table 2-5
Thickness	14 m	A	Davis (1995a)
SATURATED ZONE			
Porosity, n	0.25	A	Davis, 1995b
Bulk density, ρ_b	2.0 g/cm ³	A	Shaia, 1995
Distribution coefficients for geologic media, K_d	Various		See Table 2-5
Mixing depth, d_m	9 m	C	Davis, 1995b
Darcy velocity, q_{gw}	25 m/y	C	Davis, 1995b

* A=site measurement; B=result of site numerical analysis; C=literature value selected by the site

As leachate enters the saturated zone, it was assumed to mix with uncontaminated groundwater, forming a plume with a shape controlled by aquifer and contaminant properties. Complete mixing within the aquifer was assumed to occur directly below the facility. The contaminant mixing depth was an estimated value based on assuming that complete mixing occurs across the aquifer's entire depth (see Section 2.3.2).

B.5.2 Results of the Scoping Evaluation

Application of the methodology outlined in Chapter 2 produced the results shown in Table B-10. The table shows a maximum concentration in treated MLLW (C_{Waste}) and travel time to the performance boundary for each hazardous metal as well as the values used in calculating these results.

In the analysis, the attenuation that occurred between the waste in the disposal facility and the performance boundary was represented by the product of the CRF_{Source} and the CRF_{Water} . For the 8 hazardous metals listed in Table B-10, the total CRF ranged from about 120 to 11,000.

The travel time of water from the disposal facility to the 100-m performance boundary was calculated as a basis for comparison with the retarded travel time of the hazardous metals. For PGDP, water travel time from the land surface to the performance boundary (i.e., without consideration of a disposal facility) was estimated at about 27 y. Of that time, travel time in the saturated zone was about one year.

Based on the results of the scoping analysis, the following observations can be made about disposal at PGDP of hazardous metals contained in treated MLLW:

- Calculated maximum leachate concentrations for 5 of the 8 hazardous metals are greater than the solubilities of the associated metals. These metals are considered to have unlimited values for C_{Waste} .
- Of the 3 hazardous metals that are not solubility limited, selenium has the smallest value for C_{Waste} (0.5 mg/kg) and cadmium the largest (40 mg/kg).
- For selenium, chromium, and cadmium, the 3 metals that are not solubility limited, calculated travel times to the performance boundary are 1800 y, 15,000 y, and 18,000 y, respectively. Travel time through the unsaturated zone and semi-confining layer (i.e., vertical transport) accounts for almost all of the total subsurface travel time.

Table B-10. Results of Calculations for the Water Pathway at PGDP

Hazardous Metal	Maximum Allowable Concentration in Groundwater, C_{Water}	CRF_{Source}	CRF_{Water}	Maximum Leachate Concentration, C_L	Solubility ^a	Maximum Concentration in Treated MLLW, C_{Waste}^b	Travel Time to Performance Boundary		
							Unsaturated (Vadose) Zone	Saturated Zone	Total
							(y)	(y)	(y)
Arsenic (As)	0.05	27	39	1.9E+00	3.0E-01	NL	1.3E+03	4.9E+01	1.3E+03
Barium (Ba)	1	27	39	3.9E+01	1.8E+00	NL	1.1E+05	4.0E+03	1.1E+05
Cadmium (Cd)	0.01	270	39	3.9E-01	8.0E-01	4E+01	1.7E+04	6.4E+02	1.8E+04
Chromium (Cr)	0.05	27	39	1.9E+00	2.1E+04	2E+01	1.5E+04	5.6E+02	1.5E+04
Lead (Pb)	0.05	270	39	1.9E+00	8.0E-01	NL	5.7E+04	2.2E+03	6.0E+04
Mercury (Hg)	0.002	27	39	7.7E-02	9.0E-03	NL	2.1E+04	8.0E+02	2.2E+04
Selenium (Se)	0.01	3.2	39	3.9E-01	2.8E+06	5E-01	1.7E+03	6.5E+01	1.8E+03
Silver (Ag)	0.05	3.2	39	1.9E+00	7.0E-01	NL	1.9E+04	7.2E+02	2.0E+04

a The solubility of the metal in a selected hazardous metal compound in groundwater (see Section 2.3.3)

b NL means "no limit": the maximum leachate concentration is greater than the solubility of the metal

B.6 Nevada: NEVADA TEST SITE (NTS)

The Nevada Test Site (NTS) is located in southern Nevada, approximately 105 km (65 mi) northwest of Las Vegas. The site is a DOE facility occupying 3,500 km² (1,350 mi²) of federally owned land in Nye County. The site is bordered to the west, north, and east by the U.S. Air Force Nellis Base Range, another government-owned, restricted-access area. To the south, the NTS is bordered by land under the control of the U.S. Bureau of Land Management.

For most of the sites, a generic conceptual model was used to describe the water pathway. However, data from NTS indicate that recharge to groundwater due to infiltration is probably not occurring in the unsaturated zone at the potential site for MLLW disposal (Conrad, 1993; Detty et al., 1993; REECo, 1993; REECo, 1994). Therefore, the water pathway was not considered a mechanism for transport of hazardous metals at NTS and was not analyzed in the scoping evaluation. The maximum concentrations of hazardous metals in treated MLLW and travel times through the water pathway are considered in the evaluation to be unlimited for NTS.

B.7 New Mexico: LOS ALAMOS NATIONAL LABORATORY (LANL)

Los Alamos National Laboratory (LANL) is located in Los Alamos County in north-central New Mexico, approximately 97 km (60 mi) north-northeast of Albuquerque and 40 km (25 mi) northwest of Santa Fe. The site occupies an area of 112 km² (43 mi²) located directly south of the city of Los Alamos. Most laboratory and community developments are confined to mesa tops. The surrounding area is largely undeveloped.

At the time of the evaluation, personnel at LANL were planning for on-site disposal of treated MLLW. Site technical staff at LANL have proposed constructing a mixed waste disposal facility at Technical Area 67 on Pajarito Mesa (Figure B-11) for disposal of treated MLLW from environmental restoration activities. Technical Area 67 is located directly west of existing disposal facilities at Technical Area 54 and is bounded on the north by Pajarito Canyon and on the south by Three Mile Canyon.

B.7.1 Conceptual Model and Site-Specific Data Used in the Scoping Evaluation

The conceptual model used in the scoping evaluation for LANL is illustrated in Figure B-12. The following assumptions were made in determining the geometry and behavior of the LANL flow and transport system:

- The complex stratigraphy was simplified into two units (the Bandelier Tuff and the Puye Formation) based upon similar hydrologic characteristics. Average unit thicknesses were used to approximate the assumed hydrogeologic profile.
- The Bandelier Tuff consists of alternating welded (highly fractured) and non-welded (less fractured) units. Liquid-phase fracture flow was assumed to occur in the upper fractured tuff unit (uppermost unit of the Bandelier Tuff), thus creating a "fast-path." Based on this assumption, this unit was considered to have negligible travel time and its 27-m thickness was not included in the assumed hydrologic stratigraphy.
- Groundwater flow was assumed to occur in the uppermost portion of the aquifer, the Puye Formation.

The site-specific data used in the scoping evaluation are listed in Table B-11.

Although engineered barriers were assumed to remain intact for 100 y (30 y of detention plus 70 y limited by the RCRA cover system), vertical flow through the facility immediately after disposal was assumed to be the average recharge through local soils, 0.02 m/y, because it is less than the assumed rate of water moving through the facility's intact RCRA cap (0.03 m/y [see Section 2.2.2]). Engineered barriers were assumed to fail instantaneously at 100 y, and the rate of water flowing through the facility after that time was assumed to remain the same as the average recharge through local soils, 0.02 m/y.

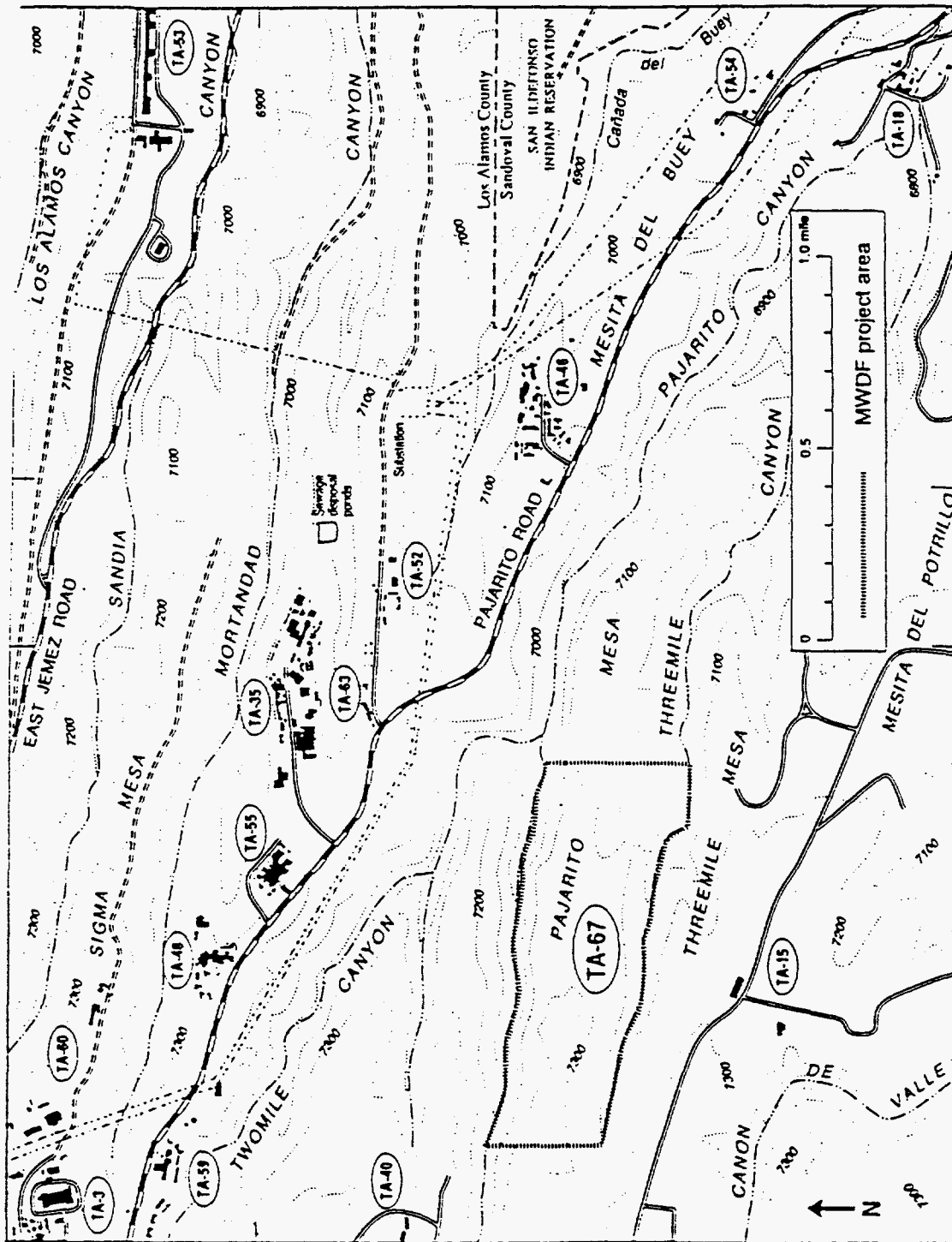

Figure B-11. Site map for Los Alamos National Laboratory (from Turin and Rosenberg, 1994).

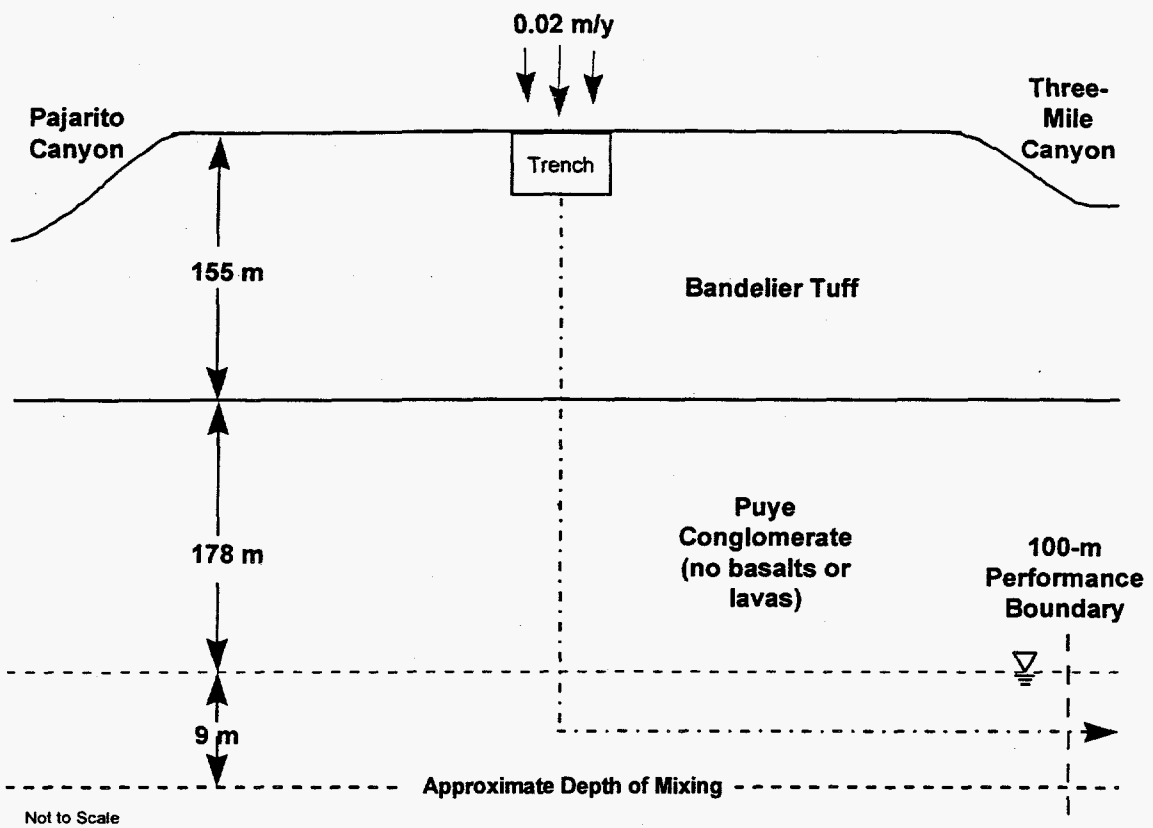

Figure B-12. Conceptual model for the water pathway at LANL.

Table B-11. Site-Specific Parameters and Values Used in the Scoping Evaluation for the Water Pathway at LANL (generic values are listed in Chapter 2) (Part 1 of 2)

Parameter	Value	Data Type*	Comments
UNSATURATED ZONE (BANDELIER TUFF)			
Natural recharge through local soils, i	0.02 m/y	B	Natural recharge rate not known. Value based on 1) precipitation, runoff, evapotranspiration data, 2) unsaturated hydraulic conductivity of the Bandelier Tuff estimated from core data, and 3) DBS&A TA-67 performance assessment modeling results
Rate of water flowing through intact disposal facility, q_f	0.02 m/y	B	Natural recharge is less than that assumed for the performance of the engineered barriers.
Moisture content, θ_w	0.05	A	Based on neutron logging results in Bandelier Tuff from TA-54 (LANL, 1992) and TA-16 (Nyhan et al., 1989)
Bulk density, ρ_b	1.22 g/cm ³	A	Rogers and Gallaher (1994, Table 22), mean from 141 core samples
Distribution coefficients for geologic media, K_d			
As, Cd, Cr, Hg, Ag	Various		Default values; see Table 2-5
Ba	950 mL/g	A	Wolfsberg, 1980
Pb	25 mL/g	A	Brookins, 1984
Se	2 mL/g	A	Brookins, 1984
Thickness between trench and Puye Conglomerate	146 m	A	Thickness from land surface to top of Puye Formation = 155 m (average thicknesses estimated from stratigraphic column presented by Broxton, Reneau, and Vaniman [1994], with uppermost unit of Bandelier Tuff removed due to "fast travel paths" through fractures)
UNSATURATED ZONE (PUYE CONGLOMERATE)			
Natural recharge through local soils, i	0.02 m/y	B	Natural recharge rate not known. Value based on 1) precipitation, runoff, evapotranspiration data, 2) unsaturated hydraulic conductivity of the Bandelier Tuff estimated from core data, and 3) DBS&A TA-67 performance assessment modeling results
Moisture content, θ_w	0.05	A	No data available; assumed to remain constant from overlying Bandelier Tuff
Bulk density, ρ_b	1.86 g/cm ³	A	CRC, 1987, Table 6-42; literature value for a mixed-grained sand, dense
Distribution coefficients for geologic media, K_d	Various		Default values; see Table 2-5
Thickness	178 m	A	Depth-to-water-table estimate reported by Broxton, Reneau, and Vaniman [1994] minus 155 m [the assumed Bandelier Tuff thickness]

Table B-11. Site-Specific Parameters and Values Used in the Scoping Evaluation for the Water Pathway at LANL (generic values are listed in Chapter 2) (Part 2 of 2)

Parameter	Value	Data Type*	Comments
SATURATED ZONE (PUYE CONGLOMERATE)			
Porosity, n	0.30	A	Freeze and Cherry (1979, Table 2.4, p.37). Within range of porosities reported for a sand and a conglomerate.
Bulk density, ρ_b	1.86 g/cm ³	A	CRC, 1987, Table 6-42; literature value for a mixed-grained sand, dense
Distribution coefficients for geologic media, K_d	Various		Default values; see Table 2-5
Mixing depth, d_m	9 m	B	Depth of mixing predicted by PAGAN code (Chu et al., 1991) at a 100-m boundary at steady state.
Darcy velocity, q_{gw}	23 m/y	A	Based on seepage velocity value of 76 m/y (Purtymun, 1984, p.18).

* A=site measurement; B=result of site numerical analysis; C=literature value selected by the site

As leachate entered the saturated zone, it was assumed to mix with uncontaminated groundwater, forming a plume with a shape controlled by aquifer and contaminant properties. Complete mixing within the aquifer was assumed to occur directly below the facility. The contaminant mixing depth of 9 m was an estimated value of plume thickness due to vertical dispersion at the 100-m performance boundary (see Section 2.3.2).

B.7.2 Results of the Scoping Evaluation

Application of the methodology outlined in Chapter 2 produced the results shown in Table B-12. The table shows a maximum concentration in treated MLLW (C_{Waste}) and travel time to the performance boundary for each hazardous metal as well as the values used in calculating these results.

In the analysis, the attenuation that occurred between the waste in the disposal facility and the performance boundary was represented by the product of the CRF_{Source} and the CRF_{Water} . For the 8 hazardous metals listed in Table B-12, the total CRF ranged from about 670 to 57,000.

The travel time of water from the disposal facility to the 100-m performance boundary was calculated as a basis for comparison with the retarded travel time of the hazardous metals. For LANL, water travel time from the land surface to the performance boundary (i.e., without consideration of a disposal facility) was estimated at about 830 y. Of that time, travel time in the saturated zone was about one year.

Table B-12. Results of Calculations for the Water Pathway at LANL

Hazardous Metal	Maximum Allowable Concentration in Groundwater, C_{Water}	CRF_{Source}	CRF_{Water}	Maximum Leachate Concentration, C_L	Solubility ^a	Maximum Concentration in Treated MLLW, C_{Waste}^b	Travel Time to Performance Boundary		
							Unsaturated (Vadose) Zone	Saturated Zone	Total
							(y)	(y)	(y)
Arsenic (As)	0.05	27	210	1.0E+01	3.0E-01	NL	5.4E+04	5.0E+01	5.4E+04
Barium (Ba)	1	27	210	2.1E+02	1.8E+00	NL	8.5E+06	4.0E+03	8.5E+06
Cadmium (Cd)	0.01	270	210	2.1E+00	8.0E-01	NL	7.1E+05	6.5E+02	7.1E+05
Chromium (Cr)	0.05	27	210	1.0E+01	2.1E+04	1E+02	6.2E+05	5.7E+02	6.2E+05
Lead (Pb)	0.05	270	210	1.0E+01	8.0E-01	NL	2.2E+05	2.2E+03	2.3E+05
Mercury (Hg)	0.002	27	210	4.2E-01	9.0E-03	NL	8.9E+05	8.1E+02	8.9E+05
Selenium (Se)	0.01	3.2	210	2.1E+00	2.8E+06	3E+00	1.8E+04	6.6E+01	1.8E+04
Silver (Ag)	0.05	3.2	210	1.0E+01	7.0E-01	NL	8.0E+05	7.3E+02	8.0E+05

a The solubility of the metal in a selected hazardous metal compound in groundwater (see Section 2.3.3)

b NL means "no limit": the maximum leachate concentration is greater than the solubility of the metal

Based on the results of the scoping analysis, the following observations can be made about disposal at LANL of hazardous metals contained in treated MLLW:

- Calculated maximum leachate concentrations for 6 of the 8 hazardous metals are greater than the solubilities of the associated metals. These metals are considered to have unlimited values for C_{Waste} .
- Of the two hazardous metals that are not solubility limited, selenium has the smallest value for C_{Waste} (3 mg/kg) and chromium the largest (100 mg/kg).
- For selenium and chromium, the two metals that are not solubility limited, calculated travel times to the performance boundary are 18,000 y and 620,000 y, respectively. Travel time through the unsaturated zone accounts for almost all of the total subsurface travel time.

B.8 New Mexico: SANDIA NATIONAL LABORATORIES (SNL)

Sandia National Laboratories (SNL) is located on Kirtland Air Force Base (KAFB), on the southern edge of the City of Albuquerque, New Mexico. The air force base is bordered on the north by the city, on the east by the Manzano Mountains, and on the west and south by the Isleta Indian reservation and NM State lands. The facility is adjacent to the south and east sides of the Albuquerque International Airport. The base is within several miles of the intersection of two major interstate highways, I-40 and I-25, which bisect the state into four quadrants and serve as major transportation routes through the region.

At the time of the evaluation, personnel at SNL had no plans for on-site treated MLLW disposal. Technical Area III was chosen for evaluation of a hypothetical treated MLLW disposal facility (Figure B-13) because it has areas already designated for waste management. The particular area of interest within Technical Area III (TA 3) is the southeastern corner near the Radioactive and Mixed Waste Management Facility and the Chemical Waste Landfill. This area is actively under investigation by SNL's environmental restoration program, and a large amount of data is available.

B.8.1 Conceptual Model and Site-Specific Data Used in the Scoping Evaluation

The conceptual model used in the scoping evaluation for SNL is illustrated in Figure B-14. In the unsaturated zone, flow was assumed to be one-dimensional under a unit hydraulic gradient with leachate moving vertically through the unsaturated alluvial sediments of the Santa Fe Formation to the regional aquifer. The distance from the land surface to the water table at TA3 is approximately 150 m (492 ft). The saturated portion of the Santa Fe Formation is characterized by a large, unconfined regional aquifer that is the drinking water source for the City of Albuquerque. The site-specific data used in the scoping evaluation are listed in Table B-13.

Although engineered barriers were assumed to remain intact for 100 y (30 y of detention plus 70 y limited by the RCRA cover system), vertical flow through the facility immediately after disposal was assumed to be the average recharge through local soils, 0.02 m/y, because it is less than the assumed rate of water moving through the facility's intact RCRA cap (0.03 m/y [see Section 2.2.2]). Engineered barriers were assumed to fail instantaneously at 100 y, so that the rate of water flowing through the facility after that time was assumed to remain the same as the average recharge through local soils, 0.02 m/y.

As leachate entered the saturated zone, it was assumed to mix with uncontaminated groundwater, forming a plume with a shape controlled by aquifer and contaminant properties. Complete mixing within the aquifer was assumed to occur directly below the facility. The contaminant mixing depth of 15 m was an estimated of plume thickness due to vertical dispersion at the 100-m performance boundary (see Section 2.3.2).

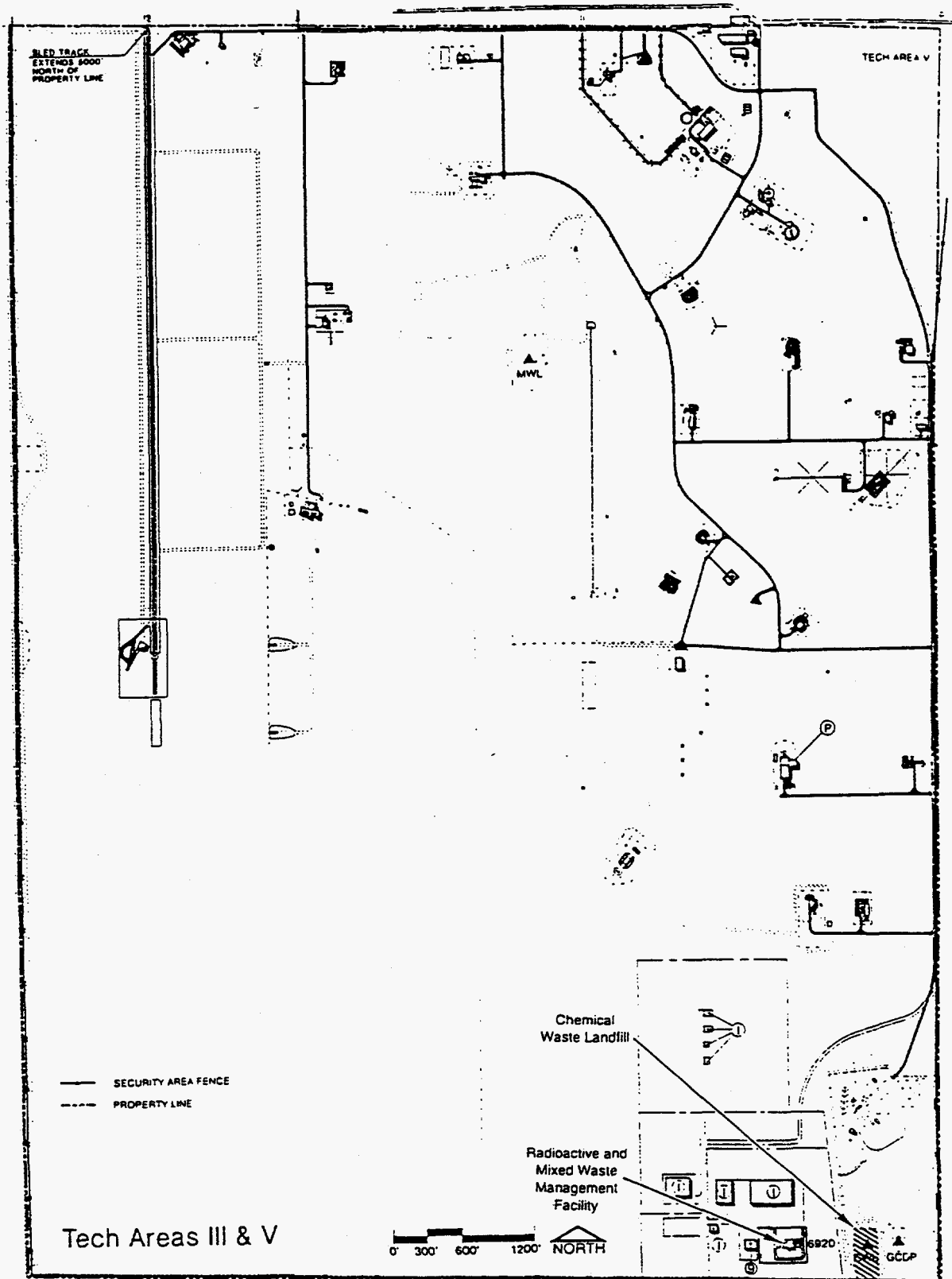

Figure B-13. Location of the Radioactive and Mixed Waste Management Facility and the Chemical Waste Landfill in Technical Area III at SNL.

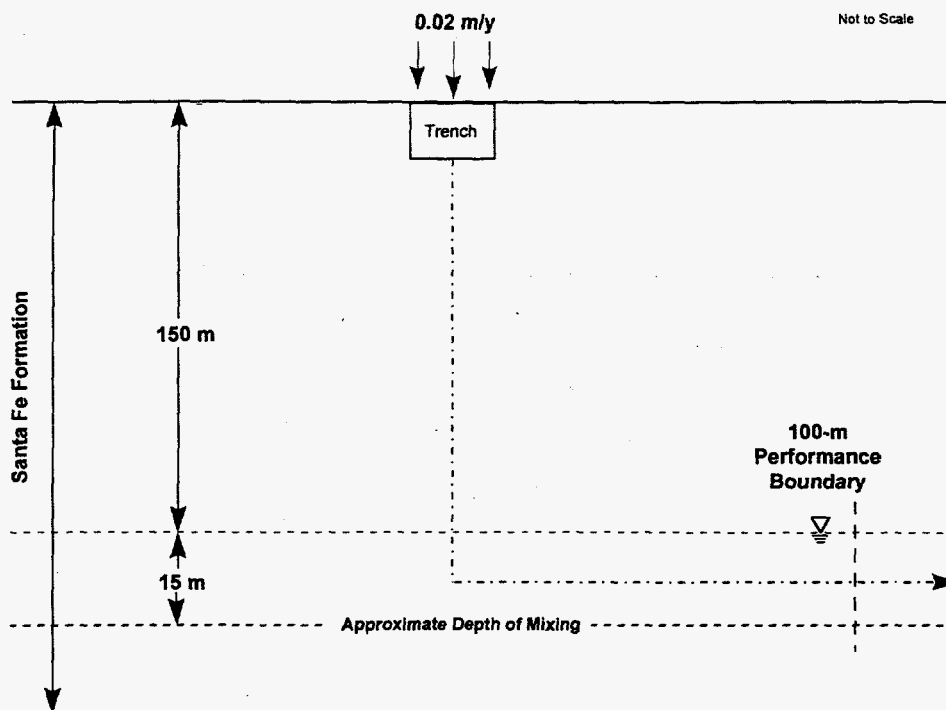

Figure B-14. Conceptual model for the water pathway at SNL.

Table B-13. Site-Specific Parameters and Values Used in the Scoping Evaluation for the Water Pathway at SNL (generic values are listed in Chapter 2)

Parameter	Value	Data Type*	Comments
UNSATURATED ZONE			
Natural recharge through local soils, i	0.02 m/y	B	SNL, 1994, p. 5-115. Within the reported range of 0.05 - 5 cm/y, the selected value is 10% of the average precipitation rate.
Rate of water flowing through intact disposal facility, q_f	0.02 m/y	B	Natural recharge is less than that assumed for the performance of the engineered barriers
Moisture content, θ_w	0.07	A	SNL, 1994, p. 4-25.
Bulk density, ρ_b	1.8 g/cm ³	A	SNL, 1994, p. 4-25; Strong, 1995.
Distribution coefficients for geologic media, K_d	Various		Default values; see Table 2-5
Thickness between trench and saturated zone, l_v	141.2 m	D	Generic trench is 8.8 meters deep.
SATURATED ZONE			
Porosity, n	0.30	A	SNL, 1994, p. 4-25.
Bulk density, ρ_b	1.8 g/cm ³	A	SNL, 1994, p. 4-25.
Distribution coefficients for geologic media, K_d	Various		Default values; see Table 2-5
Mixing depth, d_m	15 m	B	Calculated by Sandia National Laboratories using PAGAN (Chu et al., 1991)
Darcy velocity, q_{gw}	0.5 m/y	A	Product of hydraulic conductivity (126 m/y; SNL, 1994, p. 4-25) and hydraulic gradient (0.004; SNL, 1995, Appendix A)

* A=site measurement; B=result of site numerical analysis; C=literature value selected by the site

B.8.2 Results of the Scoping Evaluation

Application of the methodology outlined in Chapter 2 produced the results shown in Table B-14. The table shows a maximum concentration in treated MLLW (C_{Waste}) and travel time to the performance boundary for each hazardous metal as well as the values used in calculating these results.

In the analysis, the attenuation that occurred between the waste in the disposal facility and the performance boundary was represented by the product of the CRF_{Source} and the CRF_{Water} . For the 8 hazardous metals listed in Table B-14, the total CRF ranged from about 27 to 2300.

The travel time of water from the disposal facility to the 100-m performance boundary was calculated as a basis for comparison with the retarded travel time of the hazardous metals. For SNL, water travel time from the land surface to the performance boundary (i.e., without consideration of a disposal facility) was estimated at about 530 y. Of that time, travel time in the saturated zone was about 60 y.

Based on the results of the scoping analysis, the following observations can be made about disposal at SNL of hazardous metals contained in treated MLLW:

- Calculated maximum leachate concentrations for 3 of the 8 hazardous metals are greater than the solubilities of the associated metals. These metals are considered to have an unlimited values for C_{Waste} .
- Values for C_{Waste} for the 5 hazardous metals that are not solubility limited range over 2 orders of magnitude. The smallest value for C_{Waste} is for selenium and the largest is for lead.
- Among the 5 hazardous metals that are not solubility limited, travel times to the performance boundary range from about 100,000 y to 3.5 million y. The shortest travel time is for selenium and the longest is for lead. Travel time through the unsaturated zone accounts for almost all of the total subsurface travel time.

Table B-14. Results of Calculations for the Water Pathway at SNL

Hazardous Metal	Maximum Allowable Concentration in Groundwater, C_{Water}	CRF_{Source}	CRF_{Water}	Maximum Leachate Concentration, C_L	Solubility ^a	Maximum Concentration in Treated MLLW, C_{Waste} ^b	Travel Time to Performance Boundary		
							Unsaturated (Vadose) Zone	Saturated Zone	Total
	(mg/L)	(dimensionless)	(dimensionless)	(mg/L)	(mg/L)	(mg/kg)	(y)	(y)	(y)
Arsenic (As)	0.05	27	8.5	4.3E-01	3.0E-01	NL	7.7E+04	2.2E+03	7.9E+04
Barium (Ba)	1	27	8.5	8.5E+00	1.8E+00	NL	6.3E+06	1.8E+05	6.5E+06
Cadmium (Cd)	0.01	270	8.5	8.5E-02	8.0E-01	1E+01	1.0E+06	2.9E+04	1.0E+06
Chromium (Cr)	0.05	27	8.5	4.3E-01	2.1E+04	5E+00	8.9E+05	2.5E+04	9.1E+05
Lead (Pb)	0.05	270	8.5	4.3E-01	8.0E-01	5E+01	3.4E+06	9.7E+04	3.5E+06
Mercury (Hg)	0.002	27	8.5	1.7E-02	9.0E-03	NL	1.3E+06	3.6E+04	1.3E+06
Selenium (Se)	0.01	3.2	8.5	8.5E-02	2.8E+06	1E-01	1.0E+05	2.9E+03	1.0E+05
Silver (Ag)	0.05	3.2	8.5	4.3E-01	7.0E-01	6E-01	1.1E+06	3.2E+04	1.2E+06

a The solubility of the metal in a selected hazardous metal compound in groundwater (see Section 2.3.3)

b NL means "no limit": the maximum leachate concentration is greater than the solubility of the metal

B.9 New York: WEST VALLEY DEMONSTRATION PROJECT (WVDP)

The West Valley Demonstration Project (WVDP) site is located in the Town of Ashford, Cattaraugus County, about 56 km (35 mi) southeast of Buffalo, New York. Regional land uses are predominantly rural, with the land immediately adjacent to the site being used primarily for agriculture or arboriculture. Land use to the northwest of the site is mostly residential.

At the time of the evaluation, personnel at the WVDP had no plans for on-site disposal of MLLW. Two inactive low-level waste (LLW) disposal facilities are located at the WVDP, one in the southern portion of the site, and one immediately outside the WVDP boundary. The hypothetical disposal facility evaluated in the scoping evaluation was located on the south plateau on state-owned land within the WVDP boundary (Figure B-15).

B.9.1 Conceptual Model and Site-Specific Data Used in the Scoping Evaluation

The conceptual model used in the scoping evaluation for WVDP is illustrated in Figure B-16. Two water pathways were considered in the performance evaluation for disposal of radionuclides at WVDP: (1) a shallow groundwater-to-ephemeral-stream-to-perennial-stream pathway, and (2) a deep groundwater-to-well pathway. The second water pathway, deep groundwater to well, was found to be the most limiting because of the amount of dilution provided in the shallow-groundwater-to-stream pathway (Waters and Gruebel, 1996, Chapter 10). Therefore, only the deep-groundwater-to-well pathway was considered in the scoping evaluation for disposal of hazardous metals. Site-specific assumptions for the WVDP site include the following:

- The hydrogeologic stratigraphy is composed of three homogeneous and isotropic units: (1) the upper Weathered Lavery Till, a highly fractured permeable unit; (2) the Unweathered Lavery Till, assumed to be unfractured with low permeability; and (3) the lower Kent Reccessional, which has higher permeability than the unweathered till.
- Flow occurs both vertically and horizontally through the Weathered Lavery Till. Lateral flow consists of 0.06 m/y of the recharge through local soils and discharges into Frank's Creek, approximately 100 m from the edge of the hypothetical disposal facility. Vertical flow that enters the Unweathered Lavery Till consists of 0.01 m/y of the recharge through local soils.
- The disposal-facility design was modified to reflect site disposal practices. The top of the trench was located one meter below the Weathered/Unweathered Lavery Till interface, within the Unweathered Lavery Till. The depth of the trench is 5 m. The flux through the trench occurs through the trench cap located at the land surface. Due to the trench location within the Unweathered Lavery Till unit, leachate moves directly from the bottom of the trench into the saturated Unweathered Lavery Till.
- One-dimensional flow through the Unweathered Lavery Till occurs vertically downward under steady-state conditions (WVNSC, Inc., 1993a).

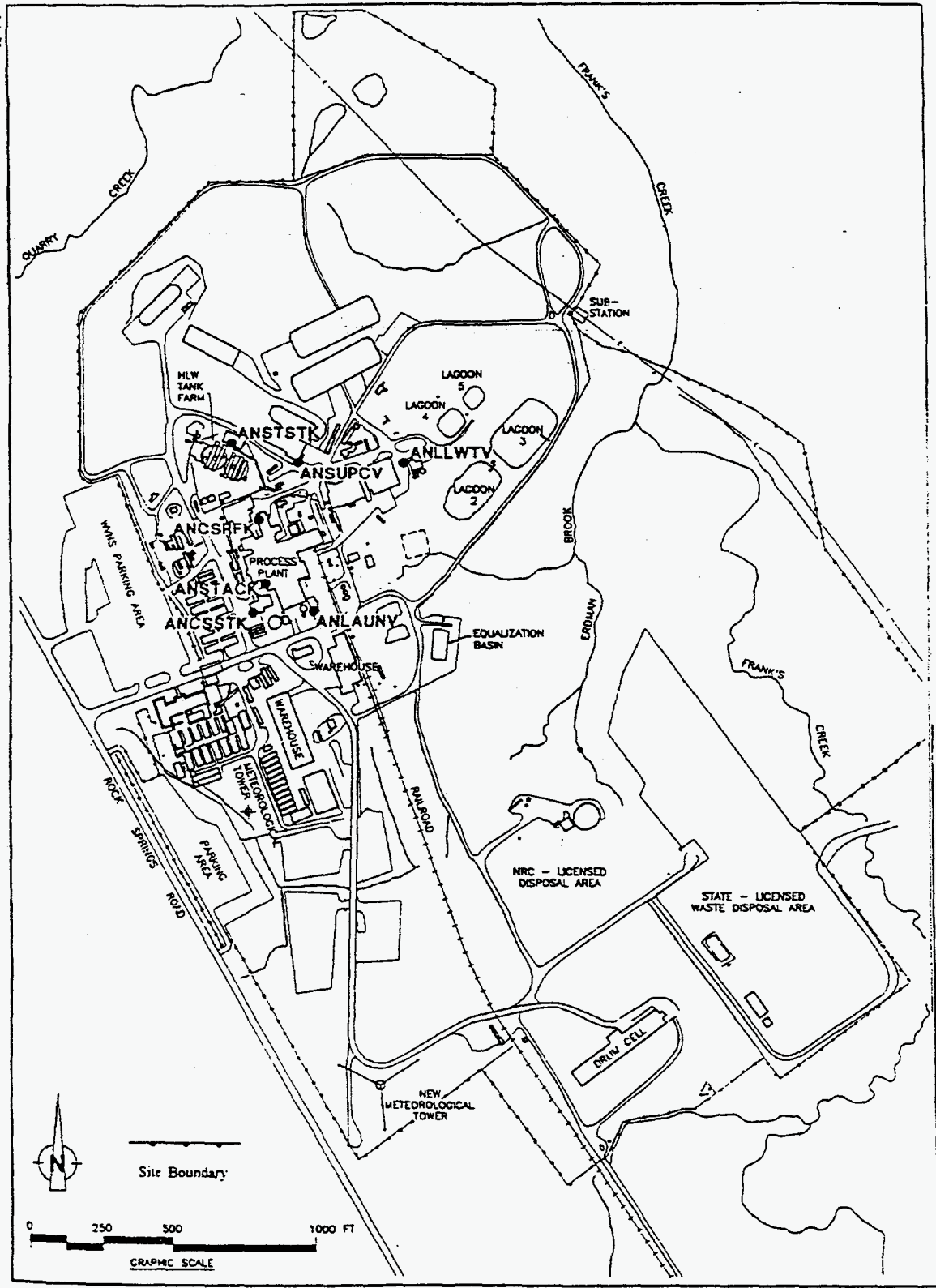

Figure B-15. General location of the hypothetical disposal facility at the WVDP (modified from WVNSC, Inc., and Dames and Moore, 1994).

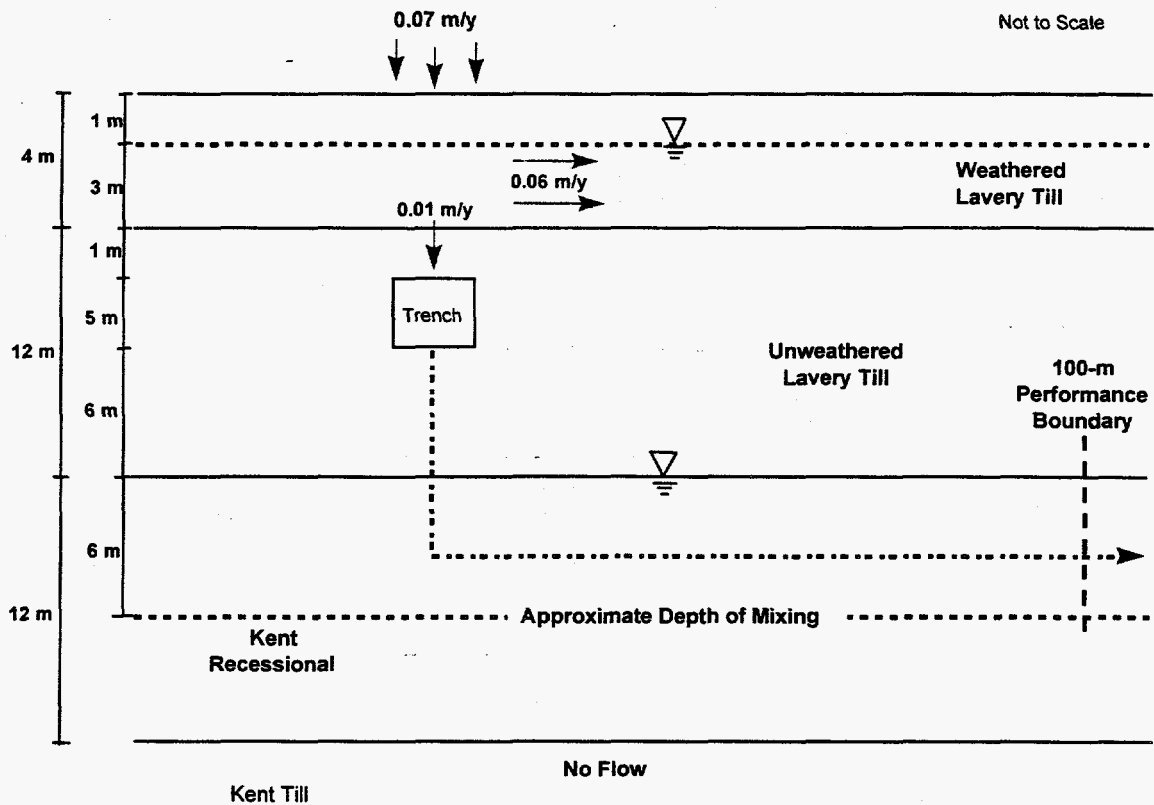

Figure B-16. Conceptual model for the water pathway at WVDP.

- One-dimensional horizontal flow occurs through the Kent Recessional deposits to a hypothetical well located at the 100-m (328-ft) performance boundary under steady-state conditions. No flow occurs into the underlying Kent Till.
- The mixing depth in the saturated zone was assumed to be 6 m (20 ft), based upon stratigraphic constraints of the Kent Recessional unit.

The site-specific data used in the scoping evaluation are listed in Table B-15.

The disposal facility design used in this scoping evaluation was a trench. However, facilities having additional engineered features are used at some sites in the humid region of the country for disposal of low-level waste. For example, a tumulus design is used at ORR (ORNL, 1994), and a vault design is used at SRS (MMES et al., 1994). These types of facilities are designed to minimize the contact of infiltrating water with the waste and may result in higher maximum concentrations for hazardous metals in treated MLLW.

Table B-15. Site-Specific Parameters and Values Used in the Scoping Evaluation for the Water Pathway at WVDP (generic values are listed in Chapter 2)

Parameter	Value	Data Type*	Comments
UNSATURATED ZONE			
Natural recharge through surface soils, i	0.07 m/y	A	WVNSC, 1993b, Sec 3.2, p. 24. (0.06 m/y assumed to flow laterally through weathered till, 0.01 m/y percolates into unweathered till).
Rate of water flowing vertically to intact disposal facility, q_f	0.01 m/y	A	WVNSC, 1993b, Sec 3.2, p. 24.
SATURATED ZONE			
Distribution coefficients for geologic media, K_d	various		Default values, see Table 2-5
Unweathered Lavery Till			
Porosity, n	0.36	A	WVNSC, 1993b, App. A, p. A-9.
Bulk density, ρ_b	1.7 g/cm ³	A	WVNSC, 1993b, App. A, p. A-9.
Thickness	12 m	A	WVNSC, 1993a, App. C. Logs for monitoring wells 1001 & 1005
Thickness between bottom of trench and top of Kent Recessional	6 m	A	Personal communication, R. Blickwedehl [Dames and Moore], 3/31/95): thickness between base of Weathered Lavery Till and top of trench (1 m) based on site practice; thickness of trench=5 m because backhoe typically can dig to 10 m below the ground surface
Vertical hydraulic gradient	0.8	A	WVNSC, 1993a, App. C. Comparison between water levels in monitoring wells 1001 & 1005, 5/91.
Vertical hydraulic conductivity, K_{sat}	4x10 ⁻⁸ cm/s	A	WVNSC, 1993a, Sec. 4.3.1.1, p. 45 (Geometric mean of 19 samples, Table 4-8, p. 190).
Kent Recessional			
Porosity, n	0.4	C	Mean estimate for silt, Freeze and Cherry (1979, p. 37).
Bulk density, ρ_b	2 g/cm ³	C	Glacial till, CRC, 1981, Table 6-42, p. 636.
Mixing depth, d_m	6 m	A	This is a very stratified, heterogeneous material. Well logs from 1001 and 1005 show a thickness of approximately 12 m. EIS assumes a 1 m thickness to be conservative. Assumed the conductive portion occurs within one-half of the total Kent Recessional thickness.
Horizontal hydraulic gradient	0.023	A	Bergeron, et al., 1987, p. 25.
Horizontal hydraulic conductivity	13.2 m/y (4.2x10 ⁻⁵ cm/s)	A	WVNSC, 1993a, Sec. 5.2.3, p. 59. Effective hydraulic conductivity for flow through parallel layers assuming 1 m thick layers which have alternating high and low hydraulic conductivities.
Darcy velocity, q_{gw}	0.31 m/y	A	Product of hydraulic gradient and hydraulic conductivity

* A=site measurement; B=result of site numerical analysis; C=literature value selected by the site

In this scoping evaluation, engineered barriers for the trench design were assumed to remain intact for 100 y (30 y of detention plus 70 y limited by the RCRA cover system). Vertical

flow through the facility immediately after disposal was assumed to be the vertical flow component of the average recharge through local soils, 0.01 m/y, because it is less than the assumed rate of water moving through the facility's RCRA cap (0.03 m/y [see Section 2.2.2]). Engineered barriers were assumed to fail instantaneously at 100 y, so that the rate of water flowing through the facility after that time was assumed to remain the same as the vertical component of the average recharge through local soils, 0.01 m/y.

As leachate entered the saturated zone, it was assumed to mix with uncontaminated groundwater, forming a plume with a shape controlled by aquifer and contaminant properties. Complete mixing within the aquifer was assumed to occur directly below the facility. The contaminant mixing depth of 6 m was an estimated value based on the stratigraphic constraints of the Kent Recessional unit (see Section 2.3.2).

B.9.2 Results of the Scoping Evaluation

Application of the methodology outlined in Chapter 2 produced the results shown in Table B-16. The table shows a maximum concentration in treated MLLW (C_{Waste}) and travel time to the performance boundary for each hazardous metal as well as the values used in calculating these results.

In the analysis, the attenuation that occurred between the waste in the disposal facility and the performance boundary was represented by the product of the CRF_{Source} and the CRF_{Water} . For the 8 hazardous metals listed in Table B-16, the total CRF ranged from about 5 to 410.

The travel time of water from the disposal facility to the 100-m performance boundary was calculated as a basis for comparison with the retarded travel time of the hazardous metals. For WVDP, water travel time from the land surface to the performance boundary (i.e., without consideration of a disposal facility) was estimated at about 670 y. Of that time, travel time in the saturated zone was about 130 y.

Based on the results of the scoping analysis, the following observations can be made about disposal at WVDP of hazardous metals contained in treated MLLW:

- For all other sites considered in the scoping evaluation, some of the calculated maximum leachate concentrations are greater than the solubilities of the associated metals; these metals are considered to have unlimited values for C_{Waste} . However, for WVDP none of the calculated maximum leachate concentrations are greater than the solubilities of their associated metals.
- Values for C_{Waste} for the 8 hazardous metals range over 3 orders of magnitude. The smallest values for C_{Waste} are for selenium and mercury and the largest is for barium.
- Among the 8 hazardous metals, travel times to the performance boundary range from about 4900 y to 400,000 y. The shortest travel time is for arsenic and the longest is for barium. Travel time through the unsaturated zone accounts for about 20% of the total subsurface travel time.

Table B-16. Results of Calculations for the Water Pathway at WVDP

Hazardous Metal	Maximum Allowable Concentration in Groundwater, C_{Water}	CRF_{Source}	CRF_{Water}	Maximum Leachate Concentration, C_L	Solubility ^a	Maximum Concentration in Treated MLLW, C_{Waste}^b	Travel Time to Performance Boundary		
							Unsaturated (Vadose) Zone	Saturated Zone	Total
							(y)	(y)	(y)
Arsenic (As)	0.05	27	1.5	7.7E-02	3.0E-01	9E-01	9.1E+02	4.0E+03	4.9E+03
Barium (Ba)	1	27	1.5	1.5E+00	1.8E+00	2E+01	7.3E+04	3.2E+05	4.0E+05
Cadmium (Cd)	0.01	270	1.5	1.5E-02	8.0E-01	2E+00	1.2E+04	5.2E+04	6.3E+04
Chromium (Cr)	0.05	27	1.5	7.7E-02	2.1E+04	9E-01	1.0E+04	4.5E+04	5.6E+04
Lead (Pb)	0.05	270	1.5	7.7E-02	8.0E-01	9E+00	3.9E+04	1.7E+05	2.1E+05
Mercury (Hg)	0.002	27	1.5	3.1E-03	9.0E-03	4E-02	1.5E+04	6.5E+04	7.9E+04
Selenium (Se)	0.01	3.2	1.5	1.5E-02	2.8E+06	2E-02	1.2E+03	5.3E+03	6.5E+03
Silver (Ag)	0.05	3.2	1.5	7.7E-02	7.0E-01	1E-01	1.3E+04	5.8E+04	7.1E+04

a The solubility of the metal in a selected hazardous metal compound in groundwater (see Section 2.3.3)

b NL means "no limit": the maximum leachate concentration is greater than the solubility of the metal

B.10 Ohio: FERNALD ENVIRONMENTAL MANAGEMENT PROJECT (FEMP)

The Fernald Environmental Management Project (FEMP) is located in southwestern Ohio, about 27 km (17 mi) northwest of downtown Cincinnati, Ohio. The facility is located just north of Fernald, a small farming community. The land contiguous to FEMP is primarily open land, such as agricultural and undeveloped lands, industrial lands, and some residential lands.

At the time of the evaluation, personnel at FEMP had no plans for on-site disposal of treated MLLW. However, some treated MLLW waste streams are expected to be generated as a result of environmental restoration activities, and a CERCLA disposal cell is being considered for FEMP. The location chosen for the hypothetical disposal facility in this scoping evaluation is in the northeastern corner of the FEMP property near the proposed facility for CERCLA remediation wastes (Figure B-17).

B.10.1 Conceptual Model and Site-Specific Data Used in the PE

The conceptual model used in the scoping evaluation for FEMP is illustrated in Figure B-18. The unsaturated zone beneath the evaluated location consists of about 6.7 m (22 ft) of unsaturated glacial till overlying the Great Miami Aquifer (GMA) but also includes the upper 6.4 m (21 ft) of the GMA, which is unsaturated (the UGMA); the total unsaturated zone thickness is 13.1 m (43 ft). The trench was assumed to be excavated through the till and into the top of the UGMA, so that 4.1 m (13.4 ft) of the UGMA comprises the entire unsaturated zone beneath the trench. The site-specific data used in the scoping evaluation are listed in Table B-17.

The disposal facility design used in this scoping evaluation was a trench. However, facilities having additional engineered features are used at some sites in the humid region of the country for disposal of low-level waste. For example, a tumulus design is used at ORR (ORNL, 1994), and a vault design is used at SRS (MMES et al., 1994). These types of facilities are designed to minimize the contact of infiltrating water with the waste and may result in higher maximum concentrations for hazardous metals in treated MLLW.

In this scoping evaluation, engineered barriers for the trench design were assumed to remain intact for 100 y (30 y of detention plus 70 y limited by the RCRA cover system). Vertical flow through the facility immediately after disposal was assumed to be 0.03 m/y, which is less than the average recharge through local soils (see Section 2.2.2). Engineered barriers were assumed to fail instantaneously at 100 y, so that the rate of water flowing through the facility after that time was assumed to be the average recharge through local soils, 0.15 m/y.

As leachate entered the saturated zone, it was assumed to mix with uncontaminated groundwater, forming a plume with a shape controlled by aquifer and contaminant properties. Complete mixing within the aquifer was assumed to occur directly below the facility. The contaminant mixing depth of 3 m was an estimated value based on the assumption that complete mixing occurs across the aquifer's entire depth (see Section 2.3.2).

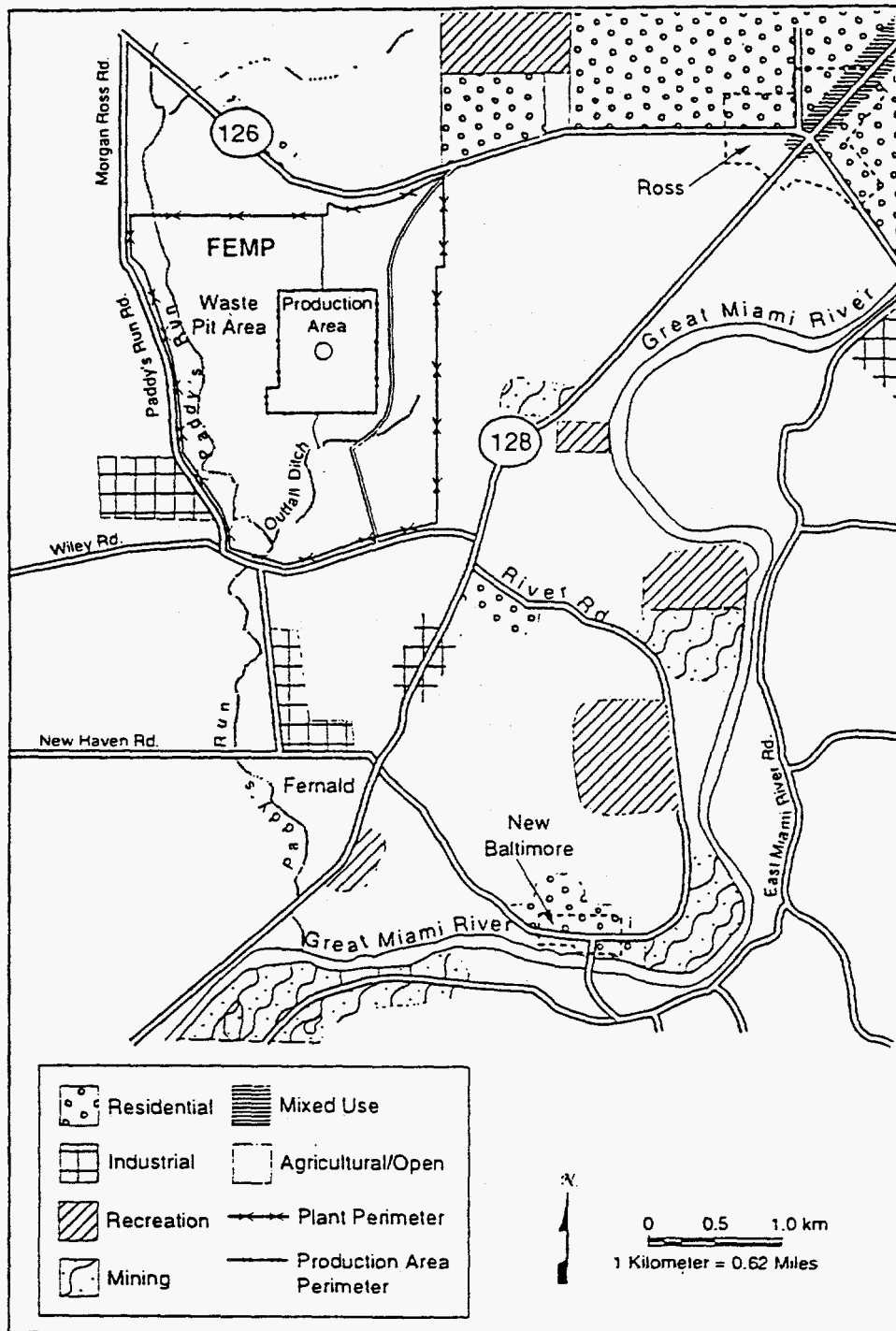

TR-6622 30-0

Figure B-17. Site map for the Fernald Environmental Management Project.

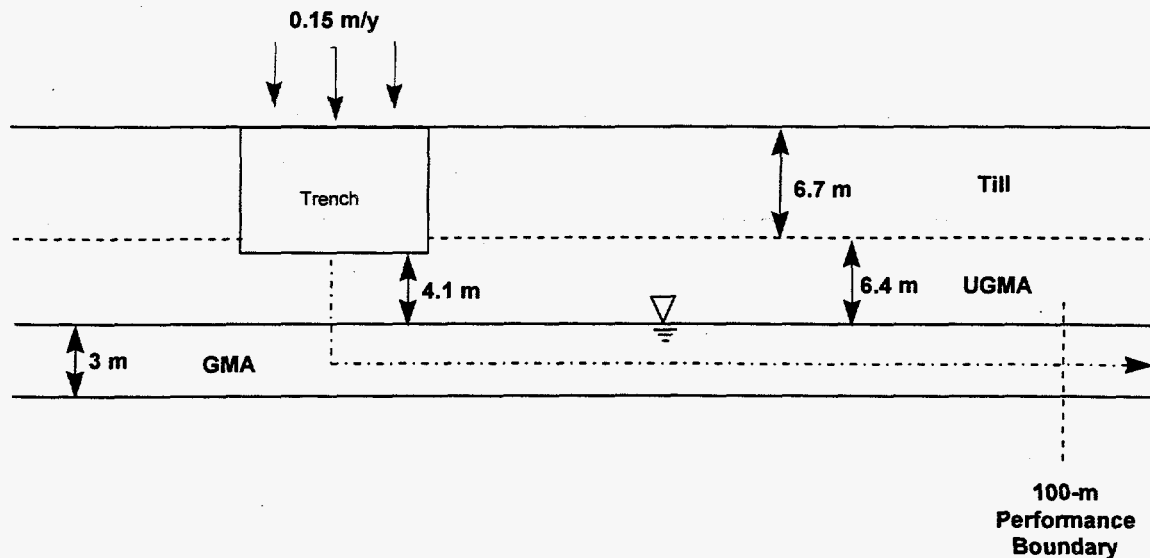

Figure B-18. Conceptual model for the water pathway at FEMP.

Table B-17. Site-Specific Parameters and Values Used in the Scoping Evaluation for the Water Pathway at FEMP (generic values are listed in Chapter 2)

Parameter	Value	Data Type*	Comments
UNSATURATED ZONE			
Natural recharge through local soils, i	0.15 m/y	A	DOE (1995, Table F.2-1)
Moisture content, θ_w	0.04	A	Unsaturated part of the Great Miami Aquifer (UGMA) (DOE, 1995, Table F.5-2). Porosity $n = 0.3$, saturation $S = 0.13$, so moisture content $\theta_w = nS = 0.04$.
Bulk density, ρ_b	1.6 g/cm ³	A	DOE (1995, Table F.5-2).
Distribution coefficients for geologic media, K_d	Various		Default values; see Table 2-5
Thickness between trench and saturated zone, l_v	4.1 m	A	DOE (1995, Figure F.5-10). Total thickness of till 1 is 6.7 m (22 ft) and trench facility bottom is 9 m below ground surface. This puts the bottom of the trench 2.3 m into the Upper Great Miami Aquifer, which has an unsaturated zone 6.4 m (20.2 ft) thick, leaving 4.1 m of unsaturated UGMA.
SATURATED ZONE			
Porosity, n	0.3	A	DOE (1995, Table F.5-2).
Bulk density, ρ_b	1.6 g/cm ³	A	DOE (1995, Table F.5-2).
Distribution coefficients for geologic media, K_d	Various		Default values; see Table 2-5
Mixing depth, d_m	3 m	C	DOE (1995, Figure F.5-10).
Darcy velocity, q_{gw}	28 m/y	C	DOE (1995, Table F.5-2).

* A=site measurement; B=result of site numerical analysis; C=literature value selected by the site

B.10.2 Results of the Scoping Evaluation

Application of the methodology outlined in Chapter 2 produced the results shown in Table B-18. The table shows a maximum concentration in treated MLLW (C_{Waste}) and travel time to the performance boundary for each hazardous metal as well as the values used in calculating these results.

In the analysis, the attenuation that occurred between the waste in the disposal facility and the performance boundary was represented by the product of the CRF_{Source} and the CRF_{Water} . For the 8 hazardous metals listed in Table B-18, the total CRF ranged from about 40 to 3200.

The travel time of water from the disposal facility to the 100-m performance boundary was calculated as a basis for comparison with the retarded travel time of the hazardous metals. For FEMP, water travel time from the land surface to the performance boundary (i.e., without consideration of a disposal facility) was estimated at about 12 y. Of that time, travel time in the saturated zone was about one year.

Based on the results of the scoping analysis, the following observations can be made about disposal at FEMP of hazardous metals contained in treated MLLW:

- Calculated maximum leachate concentrations for 3 of the 8 hazardous metals are greater than the solubilities of the associated metals. These metals are considered to have unlimited values for C_{Waste} .
- Values for C_{Waste} for the 5 hazardous metals that are not solubility limited range over 2 orders of magnitude. The smallest value for C_{Waste} is for selenium and the largest is for lead.
- Among the 5 hazardous metals that are not solubility limited, travel times to the performance boundary range from about 400 y to 13,000 y. The shortest travel time is for selenium and the longest is for lead. Travel time through the unsaturated zone accounts for almost all of the total subsurface travel time.

Table B-18. Results of Calculations for the Water Pathway at FEMP

Hazardous Metal	Maximum Allowable Concentration in Groundwater, C_{Water}	CRF_{Source}	CRF_{Water}	Maximum Leachate Concentration, C_L	Solubility ^a	Maximum Concentration in Treated MLLW, C_{Waste}^b	Travel Time to Performance Boundary		
							Unsaturated (Vadose) Zone	Saturated Zone	Total
							(y)	(y)	(y)
Arsenic (As)	0.05	27	12	6.1E-01	3.0E-01	NL	2.6E+02	3.5E+01	3.0E+02
Barium (Ba)	1	27	12	1.2E+01	1.8E+00	NL	2.2E+04	2.9E+03	2.5E+04
Cadmium (Cd)	0.01	270	12	1.2E-01	8.0E-01	1E+01	3.5E+03	4.6E+02	4.0E+03
Chromium (Cr)	0.05	27	12	6.1E-01	2.1E+04	7E+00	3.1E+03	4.0E+02	3.5E+03
Lead (Pb)	0.05	270	12	6.1E-01	8.0E-01	7E+01	1.2E+04	1.5E+03	1.3E+04
Mercury (Hg)	0.002	27	12	2.4E-02	9.0E-03	NL	4.4E+03	5.7E+02	4.9E+03
Selenium (Se)	0.01	3.2	12	1.2E-01	2.8E+06	2E-01	3.5E+02	4.7E+01	4.0E+02
Silver (Ag)	0.05	3.2	12	6.1E-01	7.0E-01	8E-01	3.9E+03	5.2E+02	4.5E+03

a The solubility of the metal in a selected hazardous metal compound in groundwater (see Section 2.3.3)

b NL means "no limit": the maximum leachate concentration is greater than the solubility of the metal

B.11 Ohio: PORTSMOUTH GASEOUS DIFFUSION PLANT (PORTS)

The Portsmouth Gaseous Diffusion Plant (PORTS) is located in sparsely populated, rural Pike County, Ohio, near the southern end of the Scioto River basin. The plant is about 1.6 km (1 mi) east of the Scioto River valley and 32 km (20 mi) north of Portsmouth, Ohio, where the Scioto River joins the Ohio River. The PORTS site occupies a 16-km² (6.3-mi²) upland area that is bounded on the east and west by ridges of low-lying hills. The plant nominal elevation is 204 m (670 ft) above the mean sea level, 40 m (130 ft) above the normal stage of the Scioto River, and 27-40 m (90-130 ft) above the mile-wide Scioto River floodplain (USGS, 1979).

At the time of the scoping evaluation, site personnel at PORTS had no plans for on-site disposal of treated MLLW. Three primary areas were identified by the site technical staff as possible sites for evaluating a hypothetical disposal facility: the north, east, and south sites, as shown in Figure B-19. The south site was chosen for the scoping evaluation because it would provide the greatest depth to groundwater.

B.11.1 Conceptual Model and Site-Specific Data Used in the Scoping Evaluation

The conceptual model used in the scoping evaluation for PORTS is illustrated in Figure B-20. The conceptual model assumed that the unsaturated zone is a unit of local surficial soils with a thickness of 5 m (16.4 ft), and the saturated zone is a 2.5-m (8.2-ft) thick unit with material properties approximating those of the Minford and Gallia unconsolidated units. This transmissive saturated zone is underlain by the Sunbury Shale, which acts as a lower impermeable layer. Because the unsaturated zone is thin, the disposal facility is designed as a mounded trench so that there is at least 1 m of unsaturated zone below the trench. The groundwater near the site is transported downgradient to the southwest (G&M, 1994). The site-specific data used in the scoping evaluation are listed in Table B-19.

The disposal facility design used in this scoping evaluation was a trench. However, facilities having additional engineered features are used at some sites in the humid region of the country for disposal of low-level waste. For example, a tumulus design is used at ORR (ORNL, 1994), and a vault design is used at SRS (MMES et al., 1994). These types of facilities are designed to minimize the contact of infiltrating water with the waste and may result in higher maximum concentrations for hazardous metals in treated MLLW.

In this scoping evaluation, engineered barriers for the trench design were assumed to remain intact for 100 y (30 y of detention plus 70 y limited by the RCRA cover system). Vertical flow through the facility immediately after disposal was assumed to be 0.03 m/y, which is less than the average recharge through local soils (see Section 2.2.2). Engineered barriers were assumed to fail instantaneously at 100 y, so that the rate of water flowing through the facility after that time was assumed to be the average recharge through local soils, 0.11 m/y.

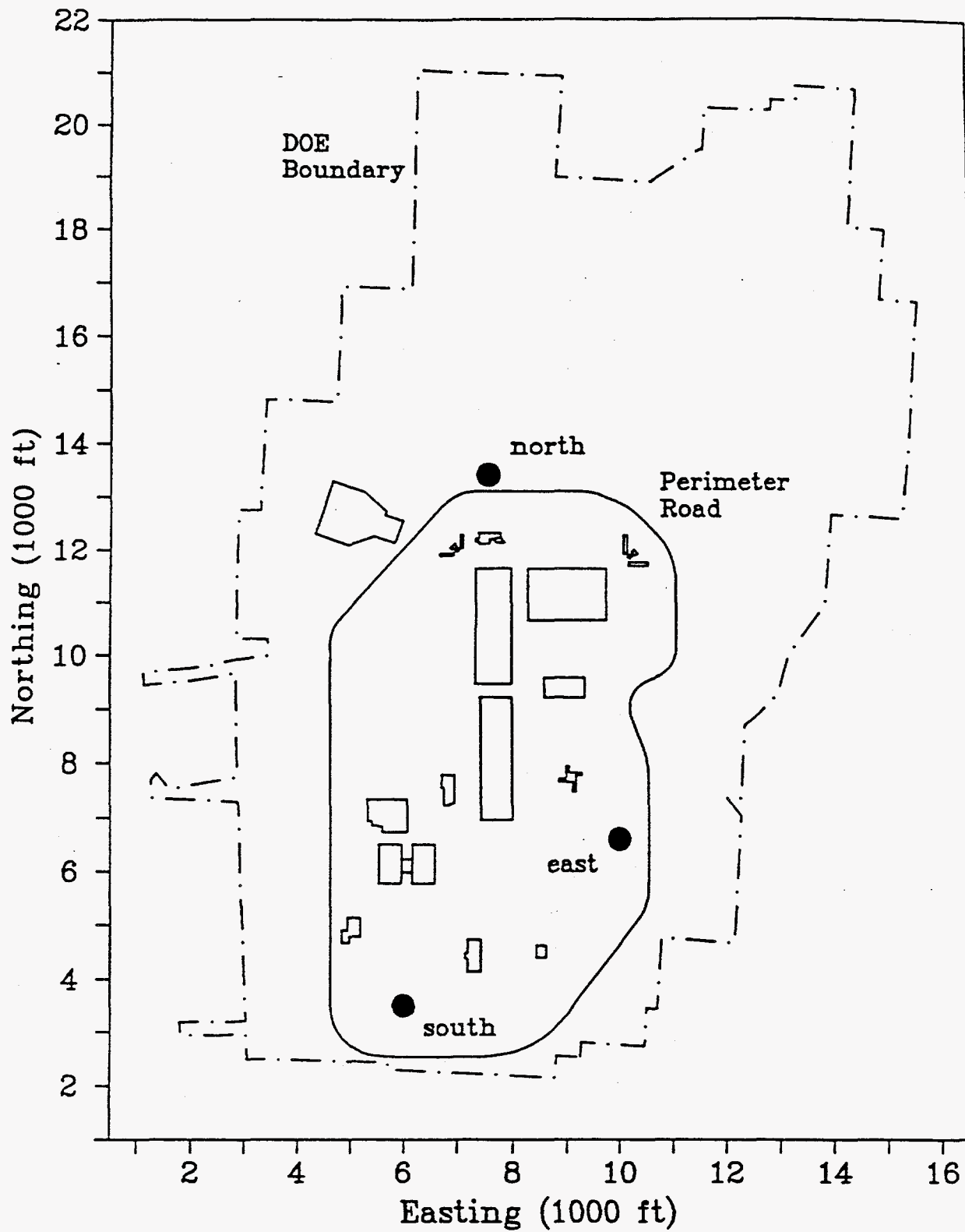

Figure B-19. Possible MLLW disposal sites (north, east, and south) at PORTS.

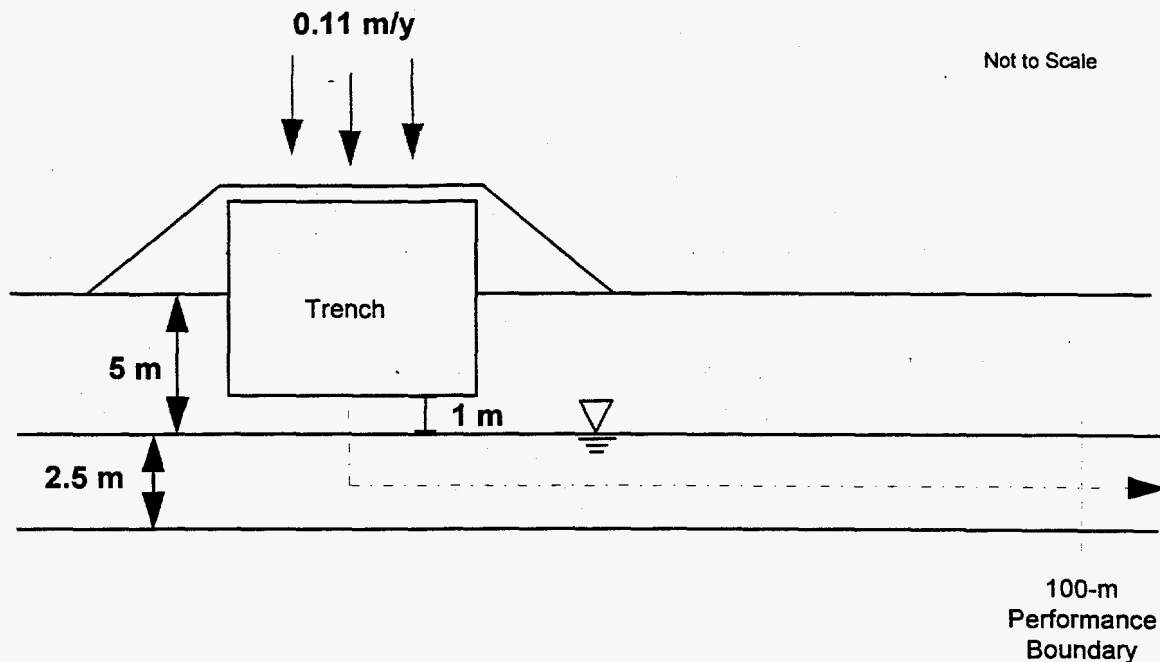

Figure B-20. Conceptual model for the water pathway at PORTS.

Table B-19. Site-Specific Parameters and Values Used in the Scoping Evaluation for the Water Pathway at PORTS (generic values are listed in Chapter 2)

Parameter	Value	Data Type*	Comments
UNSATURATED ZONE			
Natural recharge through local soils, i	0.11 m/y	A	Campbell, 1995
Moisture content, θ_w	0.22	A	Law Engineering (1982)
Bulk density, ρ_b	1.7 g/cm ³	A	Campbell, 1995
Distribution coefficients for geologic media, K_d	Various		Default values; see Table 2-5
Thickness between trench and saturated zone, l_v	1 m	A	Cumulative unsaturated sediment thickness is 5 m (G&M, 1989); trench is mounded, and bottom of generic trench facility is 4 m below ground surface
SATURATED ZONE			
Porosity, n	0.35	A	Campbell, 1995
Bulk density, ρ_b	1.5 g/cm ³	A	Campbell, 1995
Distribution coefficients for geologic media, K_d	Various		Default values; see Table 2-5
Mixing depth, d_m	2.5 m	C	G&M, 1989
Darcy velocity, q_{gw}	7.7 m/y	C	Campbell, 1995

* A=site measurement; B=result of site numerical analysis; C=literature value selected by the site

As leachate entered the saturated zone, it was assumed to mix with uncontaminated groundwater, forming a plume with a shape controlled by aquifer and contaminant properties. Complete mixing within the aquifer was assumed to occur directly below the facility. The contaminant mixing depth was an estimated value based on the assumption that complete mixing occurs across the aquifer's entire depth (see Section 2.3.2).

B.11.2 Results of the Scoping Evaluation

Application of the methodology outlined in Chapter 2 produced the results shown in Table B-20. The table shows a maximum concentration in treated MLLW (C_{Waste}) and travel time to the performance boundary for each hazardous metal as well as the values used in calculating these results.

In the analysis, the attenuation that occurred between the waste in the disposal facility and the performance boundary was represented by the product of the CRF_{Source} and the CRF_{Water} . For the 8 hazardous metals listed in Table B-20, the total CRF ranged from about 14 to 1200.

The travel time of water from the disposal facility to the 100-m performance boundary was calculated as a basis for comparison with the retarded travel time of the hazardous metals. For PORTS, water travel time from the land surface to the performance boundary (i.e., without consideration of a disposal facility) was estimated at about 15 y. Of that time, travel time in the saturated zone was about 4.5 y.

Based on the results of the scoping analysis, the following observations can be made about disposal at PORTS of hazardous metals contained in treated MLLW:

- Calculated maximum leachate concentrations for 2 of the 8 hazardous metals are greater than the solubilities of the associated metals. These metals are considered to have unlimited values for C_{Waste} .
- Values for C_{Waste} for the 6 hazardous metals that are not solubility limited range over 3 orders of magnitude. The smallest value for C_{Waste} is for selenium and the largest is for lead.
- Among the 6 hazardous metals that are not solubility limited, travel times to the performance boundary range from about 220 y to 9400 y. The shortest travel time is for arsenic and the longest is for lead. Travel time through the unsaturated zone accounts for about half of the total subsurface travel time.

Table B-20. Results of Calculations for the Water Pathway at PORTS

Hazardous Metal	Maximum Allowable Concentration in Groundwater, C_{Water}	CRF_{Source}	CRF_{Water}	Maximum Leachate Concentration, C_L	Solubility ^a	Maximum Concentration in Treated MLLW, C_{Waste}^b	Travel Time to Performance Boundary		
							Unsaturated (Vadose) Zone	Saturated Zone	Total
	(mg/L)	(dimensionless)	(dimensionless)	(mg/L)	(mg/L)	(mg/kg)	(y)	(y)	(y)
Arsenic (As)	0.05	27	4.5	2.3E-01	3.0E-01	3E+00	9.5E+01	1.2E+02	2.2E+02
Barium (Ba)	1	27	4.5	4.5E+00	1.8E+00	NL	7.7E+03	9.7E+03	1.7E+04
Cadmium (Cd)	0.01	270	4.5	4.5E-02	8.0E-01	5E+00	1.2E+03	1.6E+03	2.8E+03
Chromium (Cr)	0.05	27	4.5	2.3E-01	2.1E+04	3E+00	1.1E+03	1.4E+03	2.5E+03
Lead (Pb)	0.05	270	4.5	2.3E-01	8.0E-01	3E+01	4.2E+03	5.3E+03	9.4E+03
Mercury (Hg)	0.002	27	4.5	9.0E-03	9.0E-03	NL	1.5E+03	2.0E+03	3.5E+03
Selenium (Se)	0.01	3.2	4.5	4.5E-02	2.8E+06	6E-02	1.3E+02	1.6E+02	2.9E+02
Silver (Ag)	0.05	3.2	4.5	2.3E-01	7.0E-01	3E-01	1.4E+03	1.8E+03	3.2E+03

a The solubility of the metal in a selected hazardous metal compound in groundwater (see Section 2.3.3)

b NL means "no limit": the maximum leachate concentration is greater than the solubility of the metal

B.12 South Carolina: SAVANNAH RIVER SITE (SRS)

The Savannah River Site (SRS) is located in south-central South Carolina, approximately 160 km (100 mi) from the Atlantic Coast. The major physical feature at SRS is the Savannah River, about 28 km (17 mi) of which serve as the southwestern boundary of the site and the South Carolina-Georgia border. The SRS includes portions of Aiken, Barnwell, and Allendale Counties in South Carolina.

At the time of the evaluation, personnel at SRS were planning for on-site disposal of treated MLLW. The E-Area at SRS contains approximately 0.7 km² (200 ac) and is located immediately north of the current low-level waste (LLW) burial grounds. In order to properly dispose of hazardous material and treated MLLW generated at SRS, a project to design and construct disposal vaults was authorized in 1989. This mixed waste disposal facility (MWDF) is identified on maps but has not yet been constructed (Figure B-21). This location was chosen for the hypothetical disposal facility in the scoping evaluation.

B.12.1 Conceptual Model and Site-Specific Data Used in the Scoping Evaluation

The conceptual model used in the scoping evaluation for SRS is illustrated in Figure B-22. Assumptions for the proposed location are that (1) the subsurface stratigraphy is identical to that underlying the E-Area Vaults (as documented in the performance assessment [MMES et al., 1994]), and (2) the water table maps presented in that performance assessment are an adequate representation of the water table under the proposed MLLW disposal facilities. The depth of the unsaturated zone beneath the E-Area vaults is 17 m (55 ft). Leachate from the disposal facility was assumed to move vertically through the unsaturated zone to the uppermost aquifer, then laterally to the performance boundary. The site-specific data used in the scoping evaluation are listed in Table B-21.

The disposal facility design used in this scoping evaluation was a trench. However, facilities having additional engineered features are used at some sites in the humid region of the country for disposal of low-level waste. For example, a tumulus design is used at ORR (ORNL, 1994), and a vault design is used at SRS (MMES et al., 1994). These types of facilities are designed to minimize the contact of infiltrating water with the waste and may result in higher maximum concentrations for hazardous metals in treated MLLW.

In this scoping evaluation, engineered barriers for the trench design were assumed to remain intact for 100 y (30 y of detention plus 70 y limited by the RCRA cover system). Vertical flow through the facility immediately after disposal was assumed to be 0.03 m/y, which is less than the average recharge through local soils (see Section 2.2.2). Engineered barriers were assumed to fail instantaneously at 100 y, so that the rate of water flowing through the facility after that time was assumed to be the average recharge through local soils, 0.4 m/y.

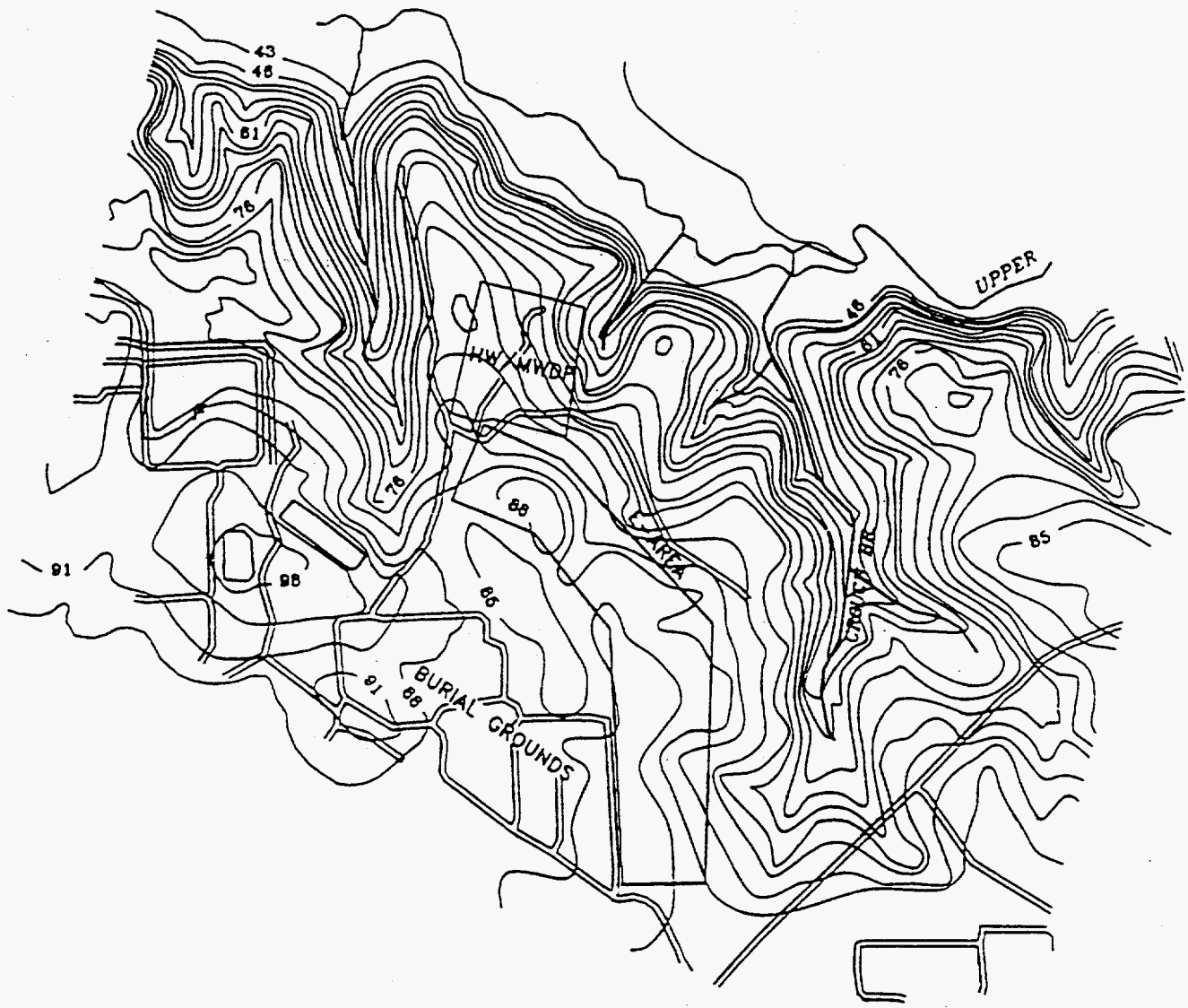

SAVANNAH RIVER PLANT
E-AREA

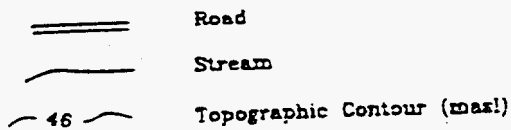
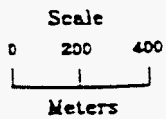

Figure B-21. Location of the proposed mixed waste disposal facility (MWDF) within the E-Area at the Savannah River Site.

Not to Scale

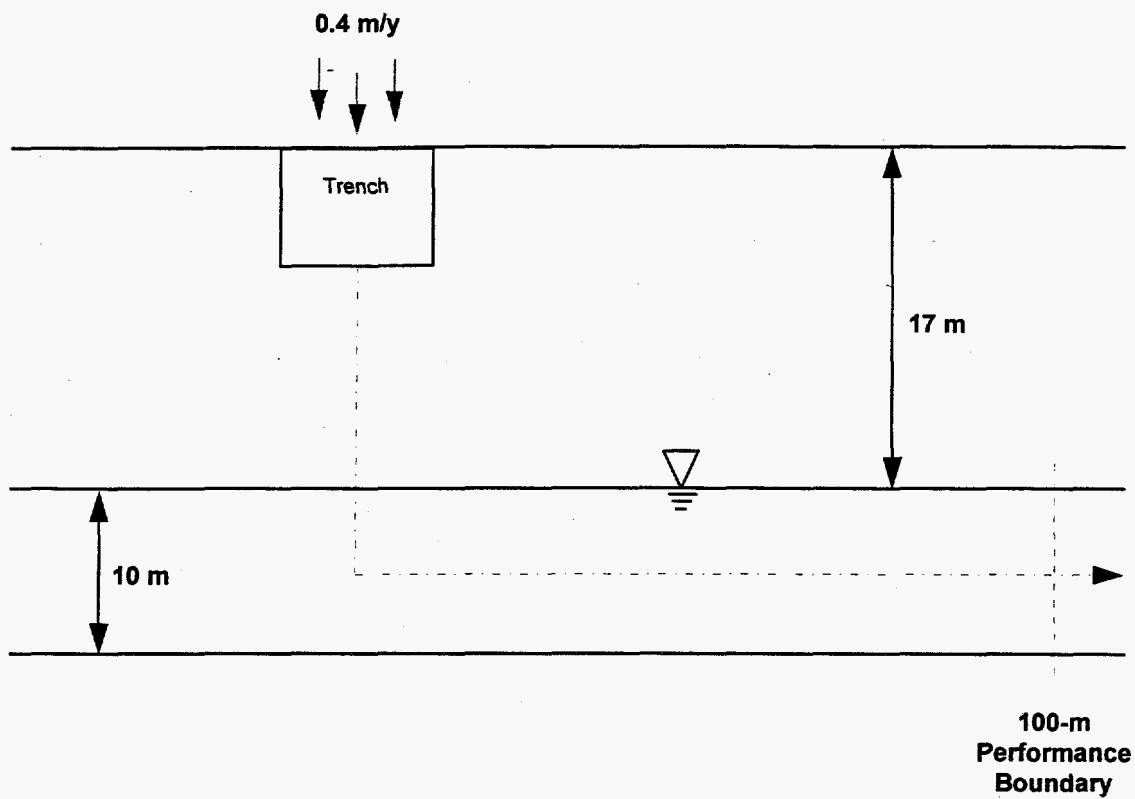

Figure B-22. Conceptual model for the water pathway at SRS.

Table B-21. Site-Specific Parameters and Values Used in the Scoping Evaluation for the Water Pathway at SRS (generic values are listed in Chapter 2)

Parameter	Value	Data Type*	Comments
UNSATURATED ZONE			
Natural recharge through local soils, i	0.4 m/y	A	MMES et al., 1994
Moisture content, θ_w	0.2	A	MMES et al., 1994
Bulk density, ρ_b	2.65 g/mL	A	MMES et al., 1994
Distribution coefficients for geologic media, K_d			
As, Cr, Hg, Ag	Various		Default values; see Table 2-5
Ba	5 mL/g	A	MMES et al., 1994, Table C.1-2
Cd	8 mL/g	A	MMES et al., 1994, Table C.1-2
Pb	100 mL/g	A	MMES et al., 1994, Table C.1-2
Se	5 mL/g	A	MMES et al., 1994, Table C.1-2
Thickness between trench and saturated zone, l_v	8 m	A	Cumulative unsaturated sediment thickness is 17 m (MMES et al., 1994) and bottom of trench is 9 m below ground surface
SATURATED ZONE			
Porosity, n	0.3	A	MMES et al., 1994
Bulk density, ρ_b	2.65 g/mL	A	MMES et al., 1994
Distribution coefficients for geologic media, K_d			
As, Cr, Hg, Ag	Various		Default values; see Table 2-5
Ba	5 mL/g	A	MMES et al., 1994, Table C.1-2
Cd	8 mL/g	A	MMES et al., 1994, Table C.1-2
Pb	100 mL/g	A	MMES et al., 1994, Table C.1-2
Se	5 mL/g	A	MMES et al., 1994, Table C.1-2
Mixing depth, d_m	10 m	C	MMES et al., 1994
Darcy velocity, q_{gw}	8.1 m/y	C	Inferred from MMES et al., 1994

* A=site measurement; B=result of site numerical analysis; C=literature value selected by the site

As leachate entered the saturated zone, it was assumed to mix with uncontaminated groundwater, forming a plume with a shape controlled by aquifer and contaminant properties. Complete mixing within the aquifer was assumed to occur directly below the facility. The contaminant mixing depth was an estimated value based on the assumption that complete mixing occurs across the aquifer's entire depth (see Section 2.3.2).

B.12.2 Results of the Scoping Evaluation

Application of the methodology outlined in Chapter 2 produced the results shown in Table B-22. The table shows a maximum concentration in treated MLLW (C_{Waste}) and travel time to the performance boundary for each hazardous metal as well as the values used in calculating these results.

In the analysis, the attenuation that occurred between the waste in the disposal facility and the performance boundary was represented by the product of the CRF_{Source} and the CRF_{Water} . For the 8 hazardous metals listed in Table B-22, the total CRF ranged from about 16 to 1400.

Table B-22. Results of Calculations for the Water Pathway at SRS

Hazardous Metal	Maximum Allowable Concentration in Groundwater, C_{Water}	CRF_{Source}	CRF_{Water}	Maximum Leachate Concentration, C_L	Solubility ^a	Maximum Concentration in Treated MLLW, C_{Waste}^b	Travel Time to Performance Boundary		
							Unsaturated (Vadose) Zone	Saturated Zone	Total
	(mg/L)	(dimensionless)	(dimensionless)	(mg/L)	(mg/L)	(mg/kg)	(y)	(y)	(y)
Arsenic (As)	0.05	27	5.1	2.5E-01	3.0E-01	3E+00	3.2E+02	2.0E+02	5.2E+02
Barium (Ba)	1	27	5.1	5.1E+00	1.8E+00	NL	2.7E+02	1.7E+02	4.4E+02
Cadmium (Cd)	0.01	270	5.1	5.1E-02	8.0E-01	6E+00	4.3E+02	2.7E+02	6.9E+02
Chromium (Cr)	0.05	27	5.1	2.5E-01	2.1E+04	3E+00	3.7E+03	2.3E+03	6.0E+03
Lead (Pb)	0.05	270	5.1	2.5E-01	8.0E-01	3E+01	5.3E+03	3.3E+03	8.6E+03
Mercury (Hg)	0.002	27	5.1	1.0E-02	9.0E-03	NL	5.3E+03	3.3E+03	8.6E+03
Selenium (Se)	0.01	3.2	5.1	5.1E-02	2.8E+06	7E-02	2.7E+02	1.7E+02	4.4E+02
Silver (Ag)	0.05	3.2	5.1	2.5E-01	7.0E-01	3E-01	4.8E+03	2.9E+03	7.7E+03

The solubility of the metal in a selected hazardous metal compound in groundwater (see Section 2.3.3)

b NL means "no limit": the maximum leachate concentration is greater than the solubility of the metal

The travel time of water from the disposal facility to the 100-m performance boundary was calculated as a basis for comparison with the retarded travel time of the hazardous metals. For SRS, water travel time from the land surface to the performance boundary (i.e., without consideration of a disposal facility) was estimated at about 12 y. Of that time, travel time in the saturated zone was about 4 y.

Based on the results of the scoping analysis, the following observations can be made about disposal at SRS of hazardous metals contained in treated MLLW:

- Calculated maximum leachate concentrations for 2 of the 8 hazardous metals are greater than the solubilities of the associated metals. These metals are considered to have unlimited values for C_{Waste} .
- Values for C_{Waste} in the waste for the 6 hazardous metals that are not solubility limited range over 3 orders of magnitude. The smallest value for C_{Waste} is for selenium and the largest is for lead.
- Among the 6 hazardous metals that are not solubility limited, travel times to the performance boundary range from about 440 y to 8600 y. The shortest travel time is for selenium and the longest is for lead. Travel time through the unsaturated zone accounts for about two-thirds of the total subsurface travel time.

B.13 Tennessee: OAK RIDGE RESERVATION (ORR)

Oak Ridge Reservation (ORR) is in eastern Tennessee about 10 km (6 mi) west of the city of Knoxville. Oak Ridge Reservation lies in a valley between the Cumberland and southern Appalachian Mountain ranges. The Cumberland Mountains are about 16 km (10 mi) to the northwest; the Great Smoky Mountains are approximately 113 km (70 mi) to the southeast. Topography limits land use in the region, but substantial agricultural lands yield hay, tobacco, and corn. The region ranges from rural to urban with a tendency toward increasing urbanization.

At the time of the evaluation, personnel at ORR were planning for on-site disposal of treated MLLW. The site is in the conceptual stages of developing a MWDF at Bear Creek Valley. The conceptual MWDF is a tumulus design with a plan area of approximately 81,600 m² (20 ac). A feasibility study for the proposed MWDF is ongoing. The location of the hypothetical disposal facility in the scoping evaluation is in Bear Creek Valley (Figure B-23).

B.13.1 Conceptual Model and Site-Specific Data Used in the Scoping Evaluation

The conceptual model used in the scoping evaluation for ORR is illustrated in Figure B-24. Three water pathways were considered in the performance assessment for disposal of LLW at ORR (ORNL, 1994):

- 1) Leachate to unsaturated zone to shallow stormflow zone to ephemeral stream to surface water,
- 2) Leachate to unsaturated zone to groundwater to ephemeral stream to surface water, and
- 3) Leachate to unsaturated zone to groundwater to well.

Although the groundwater does recharge ephemeral streams, the performance assessment results for the second pathway are generally two or more orders of magnitude lower with different peak times compared with results from the first pathway. Therefore, the groundwater-to-surface-water pathway was not considered in the performance evaluation for disposal of radionuclides in MLLW (Waters and Gruebel, 1996, Chapter 14). The following description represents the conceptual model of the water pathway that was used in the scoping evaluation for ORR:

Infiltration

- Infiltration through the bottom of the facility was assumed to be a step function that is controlled by engineered barriers during early time and natural flow conditions (i.e., the total infiltration into the facility) after the engineered barriers fail.

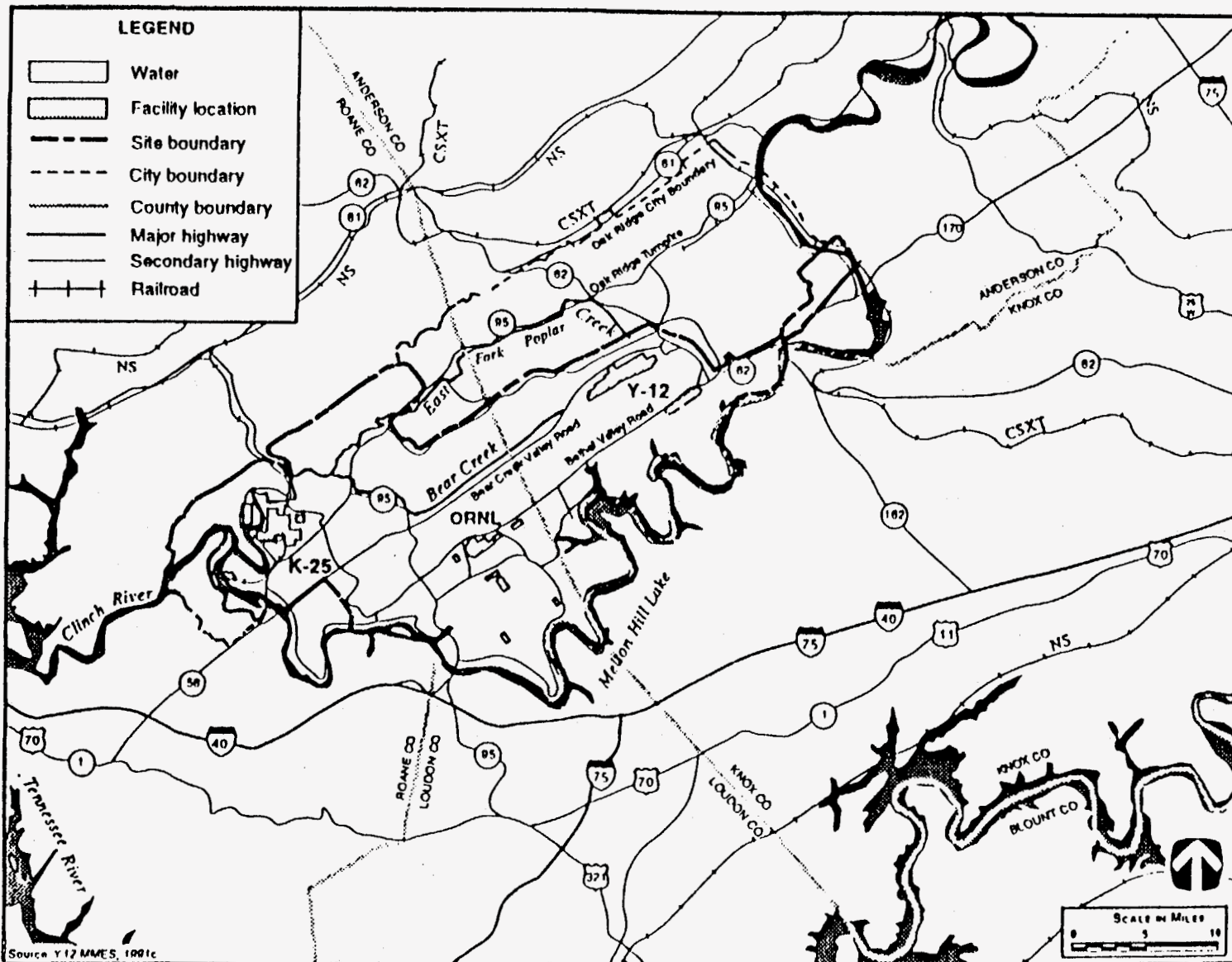
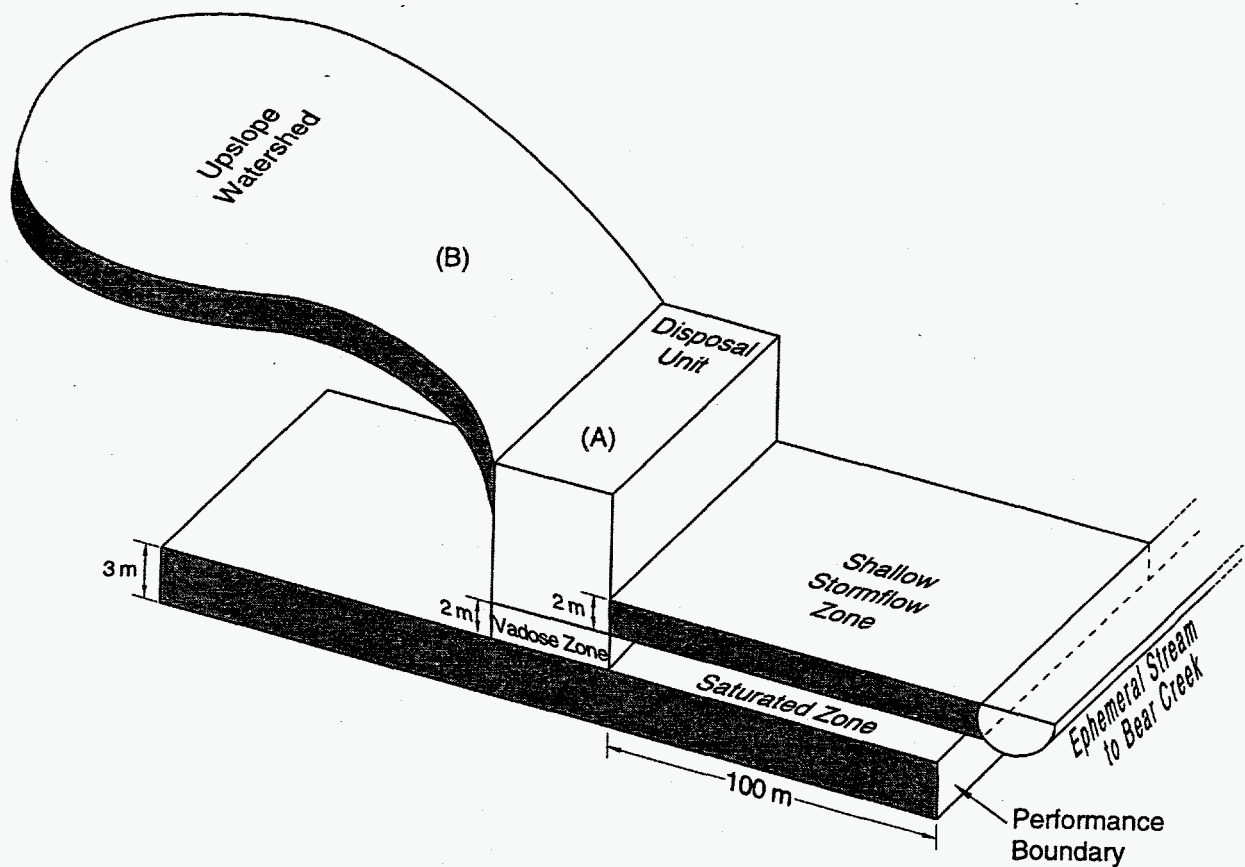

Figure B-23. Site map for Oak Ridge Reservation (ORNL, 1994).



TRI-6622-35-0

Figure B-24. Conceptual model for the water pathway at ORR.

- After engineered barriers fail, infiltration through the facility was assumed to be the sum of areal vertical recharge and upslope watershed stormflow contributions that enter the facility through the shallow stormflow zone. The contribution of flow from the up-slope area of the watershed is normalized to the facility plan area with a B/A ratio where B is the area of the up-slope watershed that flows through the facility of plan area, A . Thus, the equation for infiltration through the disposal facility is (ORNL, 1994, p. 3-27):

$$\text{Infiltration} = \text{Vertical Recharge} + \text{Shallow Stormflow} + B/A (\text{Shallow Stormflow}) \quad (3-1)$$

Unsaturated Zone

- Leachate from the disposal facility preferentially flows vertically to the water table. When the flux rate through the facility is less than the saturated hydraulic conductivity of the unsaturated zone at a unit hydraulic gradient, then all leachate flows to the aquifer. When the flux rate through the facility exceeds the saturated hydraulic conductivity of the unsaturated zone, then vertical flow occurs at a rate equal to the hydraulic conductivity while excess leachate flows through the stormflow zone. Only the leachate that flows

vertically to the water table is considered in the scoping evaluation; the performance evaluation for disposal of radionuclides in treated MLLW (Waters and Gruebel, 1996, Chapter 14) found that this pathway is the more limiting because of the amount of dilution provided in the stormflow-zone-to-ephemeral-stream-to-surface-water pathway.

- Because the unsaturated zone is highly fractured and thin at the proposed location, no credit was taken for contaminant travel time.

Groundwater Pathway

- Leachate that reaches the aquifer is instantaneously mixed over the entire water-table interval of the aquifer beneath the facility plan area to determine the dilution factor. The water-table interval is the upper part of the aquifer assumed to be the most fractured and weathered and therefore, the most conductive. The water-table interval ranges from 1 to 5 m in thickness (ORNL, 1994). The scoping evaluation for ORR assumed an aquifer mixing depth thickness of 3 m.

The site-specific data used in the scoping evaluation are listed in Table B-23.

The disposal facility design used in this scoping evaluation was a trench. However, facilities having additional engineered features are used at some sites in the humid region of the country for disposal of low-level waste. For example, a tumulus design is used at ORR (ORNL, 1994), and a vault design is used at SRS (MMES et al., 1994). These types of facilities are designed to minimize the contact of infiltrating water with the waste and may result in higher maximum concentrations for hazardous metals in treated MLLW.

In this scoping evaluation, engineered barriers for the trench design were assumed to remain intact for 100 y (30 y of detention plus 70 y limited by the RCRA cover system). Vertical flow through the facility immediately after disposal was assumed to be 0.03 m/y, which is less than the average recharge through local soils (see Section 2.2.2). Engineered barriers were assumed to fail instantaneously at 100 y, so that the rate of water flowing through the facility after that time was assumed to be the average recharge through local soils, 0.18 m/y.

As leachate entered the saturated zone, it was assumed to mix with uncontaminated groundwater, forming a plume with a shape controlled by aquifer and contaminant properties. Complete mixing within the aquifer was assumed to occur directly below the facility. The contaminant mixing depth was an estimated value based on the assumption that complete mixing occurs across the aquifer's entire depth (see Section 2.3.2).

Table B-23. Site-Specific Parameters and Values Used in the Scoping Evaluation for the Water Pathway at ORR (generic values are listed in Chapter 2)

Parameter	Value	Data Type	Comments
SHALLOW STORMFLOW ZONE			
Natural recharge through shallow soils, i_s	2.2 m/y	B	ORNL (1994). See equation 3-1 in text of this section.
Natural recharge to groundwater, i	0.18 m/y	B	ORNL (1994, p 4-6, 8)
Field capacity, θ_c	0.305	A	Field capacity is defined as the volumetric moisture content at -100 KPa (ORNL, 1994, p. D-4)
Bulk density, ρ_b	1.35 g/cm ³	A	ORNL (1994, p. E-3)
Distribution coefficients for geologic media, K_d			
As, Cr, Pb, Hg, Se, Ag	Various		Default values; see Table 2-5
Ba	3000 mL/g	A	ORNL, 1994
Cd	200 mL/g	A	ORNL, 1994
UNSATURATED ZONE			
Natural recharge to groundwater, i	0.18 m/y	B	ORNL (1994, p. 4-6, 8)
B/A: generic facility	3.4	B	MMES et al. (1994)
Moisture content, θ_w	0.39	A	ORNL, 1994, p. D-4
Bulk density, ρ_b	1.35 g/cm ³	A	ORNL, 1994
Distribution coefficients for geologic media, K_d			
As, Cr, Pb, Hg, Se, Ag	Various		Default values; see Table 2-5
Ba	3000 mL/g	A	ORNL, 1994
Cd	200 mL/g	A	ORNL, 1994
Thickness between trench and saturated zone, l_v	2 m	A	Thickness of unsaturated zone is 2 m but was eliminated from the conceptual model because it is fractured saprolite (ORNL, 1994, p. 3-15)
SATURATED ZONE			
Porosity, n	0.035	A	ORNL, 1994, and corrected based on communication between R. Waters (SNL) and M. Yambert (ORNL), 9/29/94
Bulk density, ρ_b	1.35 g/cm ³	A	ORNL, 1994, p. E-3
Distribution coefficients for geologic media, K_d			
As, Cr, Pb, Hg, Se, Ag	Various		Default values; see Table 2-5
Ba	3000 mL/g	A	ORNL, 1994
Cd	200 mL/g	A	ORNL, 1994
Mixing depth, d_m	3 m	A	ORNL, 1994, p. E-3
Darcy velocity, q_{gw}	2.92 m/y	A	ORNL, 1994

* A=site measurement; B=result of site numerical analysis; C=literature value selected by the site

B.13.2 Results of the Scoping Evaluation

Application of the methodology outlined in Chapter 2 produced the results shown in Table B-24. The table shows a maximum concentration in treated MLLW (C_{Waste}) and travel time to the performance boundary for each hazardous metal as well as the values used in calculating these results.

In the analysis, the attenuation that occurred between the waste in the disposal facility and the performance boundary was represented by the product of the CRF_{Source} and the CRF_{Water} . For the 8 hazardous metals listed in Table B-24, the total CRF ranged from about 6 to 540.

The travel time of water from the disposal facility to the 100-m performance boundary was calculated as a basis for comparison with the retarded travel time of the hazardous metals. For ORR, water travel time from the land surface to the performance boundary (i.e., without consideration of a disposal facility) was estimated at about 12 y. Of that time, travel time in the saturated zone was about one year.

Based on the results of the scoping analysis, the following observations can be made about disposal at ORR of hazardous metals contained in treated MLLW:

- The calculated maximum leachate concentration for one of the 8 hazardous metals is greater than the solubility of the associated metal. This metal, barium, is considered to have an unlimited value for C_{Waste} .
- Values for C_{Waste} for the 7 hazardous metals that are not solubility limited range over 3 orders of magnitude. The smallest values for C_{Waste} are for selenium and mercury and the largest is for lead.
- Among the 7 hazardous metals that are not solubility limited, travel times to the performance boundary range from about 280 y to 12,000 y. The shortest travel time is for arsenic and the longest is for lead. All subsurface travel time is through the saturated zone.

Table B-24. Results of Calculations for the Water Pathway at ORR

Hazardous Metal	Maximum Allowable Concentration in Groundwater, C_{Water}	CRF_{Source}	CRF_{Water}	Maximum Leachate Concentration, C_L	Solubility ^a	Maximum Concentration in Treated MLLW, C_{Waste}^b	Travel Time to Performance Boundary		
							Unsaturated (Vadose) Zone	Saturated Zone	Total
							(y)	(y)	(y)
Arsenic (As)	0.05	27	2	9.9E-02	3.0E-01	1E+00	0	2.8E+02	2.8E+02
Barium (Ba)	1	27	2	2.0E+00	1.8E+00	NL	0	1.4E+05	1.4E+05
Cadmium (Cd)	0.01	270	2	2.0E-02	8.0E-01	2E+00	0	9.2E+03	9.2E+03
Chromium (Cr)	0.05	27	2	9.9E-02	2.1E+04	1E+00	0	3.2E+03	3.2E+03
Lead (Pb)	0.05	270	2	9.9E-02	8.0E-01	1E+01	0	1.2E+04	1.2E+04
Mercury (Hg)	0.002	27	2	3.9E-03	9.0E-03	5E-02	0	4.6E+03	4.6E+03
Selenium (Se)	0.01	3.2	2	2.0E-02	2.8E+06	3E-02	0	3.7E+02	3.7E+02
Silver (Ag)	0.05	3.2	2	9.9E-02	7.0E-01	1E-01	0	4.2E+03	4.2E+03

a The solubility of the metal in a selected hazardous metal compound in groundwater (see Section 2.3.3)

b NL means "no limit": the maximum leachate concentration is greater than the solubility of the metal

B.14 Texas: PANTEX PLANT

The Pantex Plant is located in the Texas Panhandle in Carson County, Texas, about 27 km (17 miles) northeast of Amarillo. The Pantex Plant facility consists of 4,080 ha (10,080 ac), composed of 3,640 ha (9,000 ac) in the main Plant area and 440 ha (1,080 ac) located approximately 4 km (2.4 mi) northeast of the Plant area. In addition, the DOE leases 2,370 ha (5,860 ac) of land immediately south of the Plant from Texas Technological University (Texas Tech) to serve as a security buffer zone. The region is semiarid and includes extensive farming and ranching activities. In recent years several industrial facilities have located in the vicinity of Pantex.

At the time of the evaluation, site personnel at Pantex had no plans for on-site disposal of MLLW. The general location for a hypothetical disposal facility was selected by staff at Sandia National Laboratories with concurrence of the Pantex technical staff. It is in an interplaya area in Zones 4 or 5 near the northwestern corner of the site (Figure B-25). This area was chosen because groundwater recharge is lowest in the interplaya area and impact on other plant activities would be minimal.

The regional aquifer in the Tertiary Ogallala Formation is used extensively for irrigation and municipal water supply. The city of Amarillo also obtains most of their water from this aquifer; the city maintains a water-well field immediately northeast of the Pantex Plant boundary. No aquifers in this area have been designated by the EPA as sole source aquifers; however, the Ogallala is the only aquifer in this area.

Pantex is currently using performance measures in the form of Risk Reduction Rules (RRR) promulgated by the Texas Natural Resource Conservation Commission. These are health-based standards for corrective action determinations and could be used as performance measures for evaluating disposal of hazardous metals (although they are not used in this scoping evaluation). Additionally, the RRR address contaminants in soil and their potential for leachability.

B.14.1 Conceptual Model and Site-Specific Data Used in the Scoping Evaluation

The conceptual model used in the scoping evaluation for Pantex is illustrated in Figure B-26. The model consists of three units. The upper unsaturated zone includes soils from the Blackwater Draw Formation and the Upper Ogallala Formation. A perched water zone is present at several locations at the Pantex Plant. Some perched water zones are the result of natural recharge mechanisms, as evidenced by playas unaffected by site activities. However, data indicate that this perched water zone is not continuous, that it is not a true aquifer because it cannot provide usable quantities of water, and that its presence may be the result of plant activities. Lateral transport to the performance boundary is assumed to occur below the perched zone in the Ogallala aquifer. The scoping evaluation did not address potential migration pathways such as abandoned wells. The site-specific data used in the evaluation are listed in Table B-25.

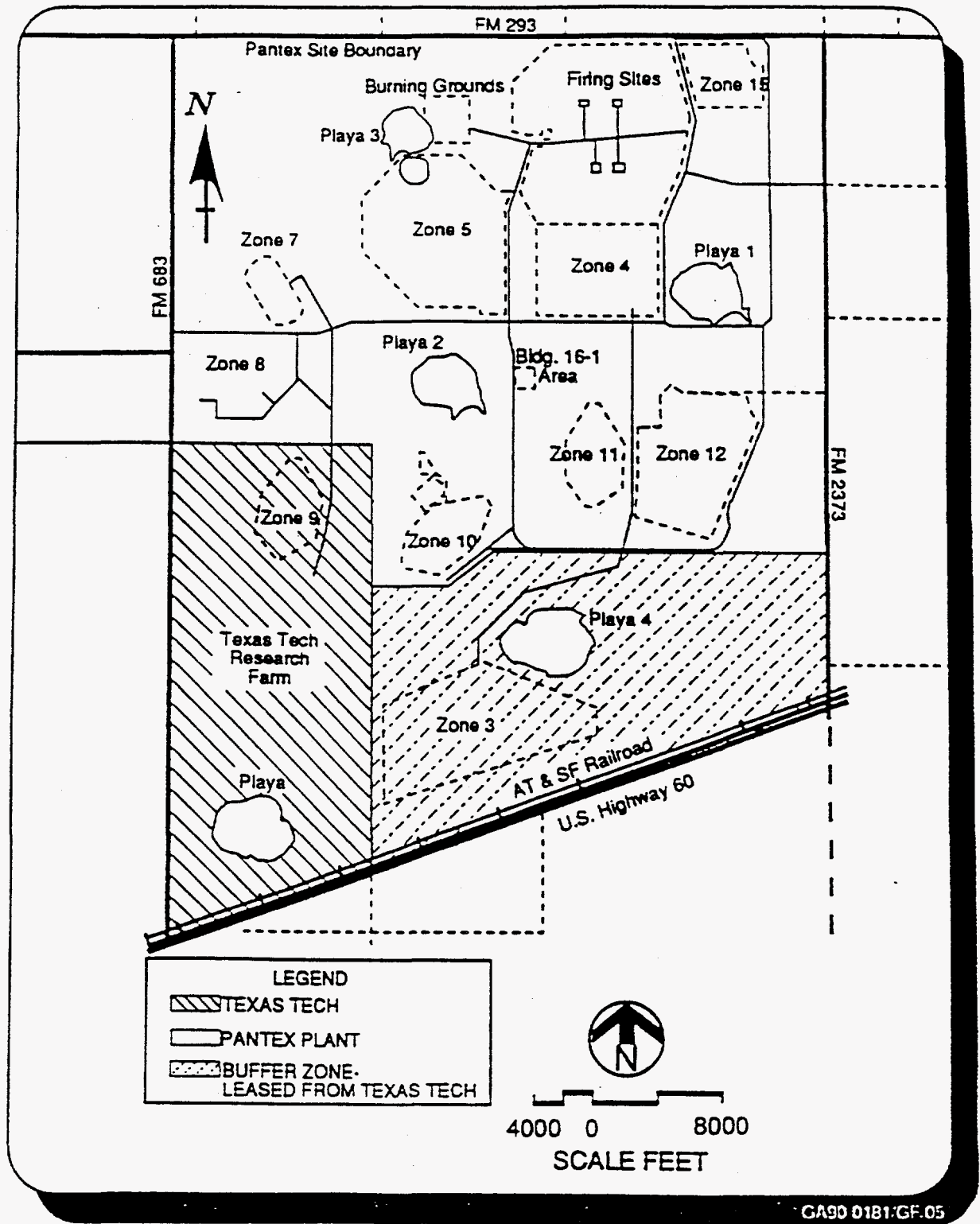

Figure B-25. Site map for Pantex Plant.

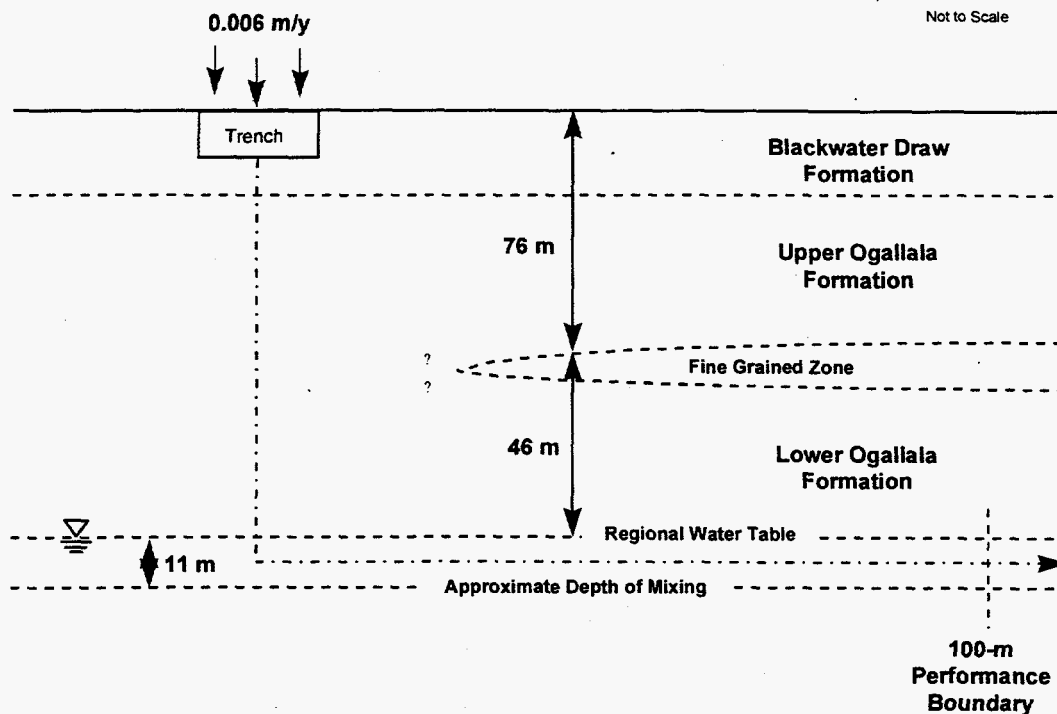

Figure B-26. Conceptual model for the water pathway at the Pantex Plant.

Table B-25. Site-Specific Parameters and Values Used in the Scoping Evaluation for the Water Pathway at Pantex (generic values are listed in Chapter 2)

Parameter	Value	Data Type*	Comments
UNSATURATED ZONE			
Natural recharge through local soils, i	0.006 m/y	C	Wood and Sanford (1995)
Annual rate of water flowing through intact disposal facility, q_f	0.006 m/y	C	Natural recharge is less than that assumed for the performance of the engineered barriers
Moisture content, θ_w	0.10	C	Calculated value
Bulk density, ρ_b	1.9 g/cm ³	A	Calculated from data in Battelle Pantex (1994)
Distribution coefficients for geologic media, K_d	Various		Default values; see Table 2-5
Thickness between trench and saturated zone, l_v	113 m	A	Battelle Columbus (1995), Figure 4.3.1-2
SATURATED ZONE			
Porosity, n	0.25	A	Battelle Columbus (1995), page 4-24
Bulk density, ρ_b	1.9 g/cm ³	A	Calculated from data in Battelle Pantex (1994)
Distribution coefficients for geologic media, K_d	Various		Default values; see Table 2-5
Mixing depth, d_m	11 m	B	Predicted by PAGAN code (Chu et. al., 1991)
Darcy velocity, q_{gw}	6 m/y	A	Calculated from data in Battelle Columbus (1995), page 4-24

* A=site measurement; B=result of site numerical analysis; C=literature value selected by the site

Although engineered barriers were assumed to remain intact for 100 y (30 y of detention plus 70 y limited by the RCRA cover system), vertical flow through the facility immediately after disposal was assumed to be the average recharge through local soils, 0.006 m/y, because it is less than the assumed rate of water moving through the facility's intact RCRA cap (0.03 m/y [see Section 2.2.2]). Engineered barriers were assumed to fail instantaneously at 100 y, so that the rate of water flowing through the facility after that time was assumed to remain the same as the average recharge through local soils, 0.006 m/y.

As leachate entered the saturated zone, it was assumed to mix with uncontaminated groundwater, forming a plume with a shape controlled by aquifer and contaminant properties. Complete mixing within the aquifer was assumed to occur directly below the facility. The contaminant mixing depth was an estimated value of plume thickness due to vertical dispersion at the 100-m performance boundary (see Section 2.3.2).

B.14.2 Results of the Scoping Evaluation

Application of the methodology outlined in Chapter 2 produced the results shown in Table B-26. The table shows a maximum concentration in treated MLLW (C_{Waste}) and travel time to the performance boundary for each hazardous metal as well as the values used in calculating these results.

In the analysis, the attenuation that occurred between the waste in the disposal facility and the performance boundary was represented by the product of the CRF_{Source} and the CRF_{Water} . For the 8 hazardous metals listed in Table B-26, the total CRF ranged from about 700 to 59,000.

The travel time of water from the disposal facility to the 100-m performance boundary was calculated as a basis for comparison with the retarded travel time of the hazardous metals. For Pantex, water travel time from the land surface to the performance boundary (i.e., without consideration of a disposal facility) was estimated at about 2000 y. Of that time, travel time in the saturated zone was about 4 y.

Based on the results of the scoping analysis, the following observations can be made about disposal at Pantex of hazardous metals contained in treated MLLW:

- Calculated maximum leachate concentrations for 6 of the 8 hazardous metals are greater than the solubilities of the associated metals. These metals are considered to have unlimited values for C_{Waste} .
- Of the 2 hazardous metals that are not solubility limited, selenium has the smallest value for C_{Waste} (3 mg/kg) and chromium the largest (100 mg/kg).
- For selenium and chromium, the 2 metals that are not solubility limited, calculated travel times to the performance boundary are 290,000 y and 2.5 million y, respectively. Travel time through the unsaturated zone accounts for almost all of the total subsurface travel time.

Table B-26. Results of Calculations for the Water Pathway at Pantex

Hazardous Metal	Maximum Allowable Concentration in Groundwater, C_{Water}	CRF_{Source}	CRF_{Water}	Maximum Leachate Concentration, C_L	Solubility ^a	Maximum Concentration in Treated MLLW, C_{Waste}^b	Travel Time to Performance Boundary		
							Unsaturated (Vadose) Zone	Saturated Zone	Total
							(y)	(y)	(y)
Arsenic (As)	0.05	27	220	1.1E+01	3.0E-01	NL	2.2E+05	1.9E+02	2.2E+05
Barium (Ba)	1	27	220	2.2E+02	1.8E+00	NL	1.8E+07	1.6E+04	1.8E+07
Cadmium (Cd)	0.01	270	220	2.2E+00	8.0E-01	NL	2.9E+06	2.5E+03	2.9E+06
Chromium (Cr)	0.05	27	220	1.1E+01	2.1E+04	1E+02	2.5E+06	2.2E+03	2.5E+06
Lead (Pb)	0.05	270	220	1.1E+01	8.0E-01	NL	9.7E+06	8.6E+03	9.7E+06
Mercury (Hg)	0.002	27	220	4.4E-01	9.0E-03	NL	3.6E+06	3.2E+03	3.6E+06
Selenium (Se)	0.01	3.2	220	2.2E+00	2.8E+06	3E+00	2.9E+05	2.6E+02	2.9E+05
Silver (Ag)	0.05	3.2	220	1.1E+01	7.0E-01	NL	3.2E+06	2.9E+03	3.2E+06

a The solubility of the metal in a selected hazardous metal compound in groundwater (see Section 2.3.3)

b NL means "no limit": the maximum leachate concentration is greater than the solubility of the metal

B.15 Washington: HANFORD SITE

The Hanford Site is located in the southeast corner of Washington State in a structural and topographic depression of the Columbia Plateau known as the Pasco Basin. The northern and eastern boundaries of the site generally follow the Columbia River. The Rattlesnake Hills bound the western portion of the site, and the Yakima River bounds the southern portion. The Hanford Site consists of approximately 1,450 km² (560 mi²) of treeless, semiarid land. With the exception of a few natural basalt hills, the site is relatively flat.

At the time of the evaluation, personnel at Hanford were planning for on-site disposal of treated MLLW. Shallow land disposal of solid waste has occurred at the Hanford Site since the late 1940s, and the Hanford Site has active LLW disposal facilities. Disposal of treated MLLW is planned in the southern end of the W-5 Burial Ground in the 200 West Area Burial Grounds (Figure B-27). The location of the hypothetical disposal facility in the scoping evaluation is the same as the planned facility in the W-5 Burial Ground.

B.15.1 Conceptual Model and Site-Specific Data Used in the Scoping Evaluation

The conceptual model used in the scoping evaluation for Hanford is illustrated in Figure B-28. The 200 West Area is underlain by a generally flat-lying sedimentary sequence about 200 m (650 ft) in thickness over basalt flows typical of the Columbia River Plateau. The uppermost basalt flow is overlain by the Ringold Formation, which is subdivided into Basal, Lower, Middle, and Upper units, with the water table located in the Middle Ringold at a depth of about 72 m (230 ft). The site-specific data used in the scoping evaluation are listed in Table B-27.

Because engineered barriers were assumed to remain intact for 100 y (30 y of detention plus 70 y limited by the RCRA cover system), vertical flow through the facility immediately after disposal was assumed to be 0.03 m/y, which is less than the average recharge through local soils (see Section 2.2.2). Engineered barriers were assumed to fail instantaneously at 100 y, so that the rate of water flowing through the facility after that time was assumed to be the average recharge through local soils, 0.05 m/y.

As leachate entered the saturated zone, it was assumed to mix with uncontaminated groundwater, forming a plume with a shape controlled by aquifer and contaminant properties. Complete mixing within the aquifer was assumed to occur directly below the facility. The contaminant mixing depth was an estimated value based on the assumption that complete mixing occurs across the aquifer's entire depth (see Section 2.3.2).

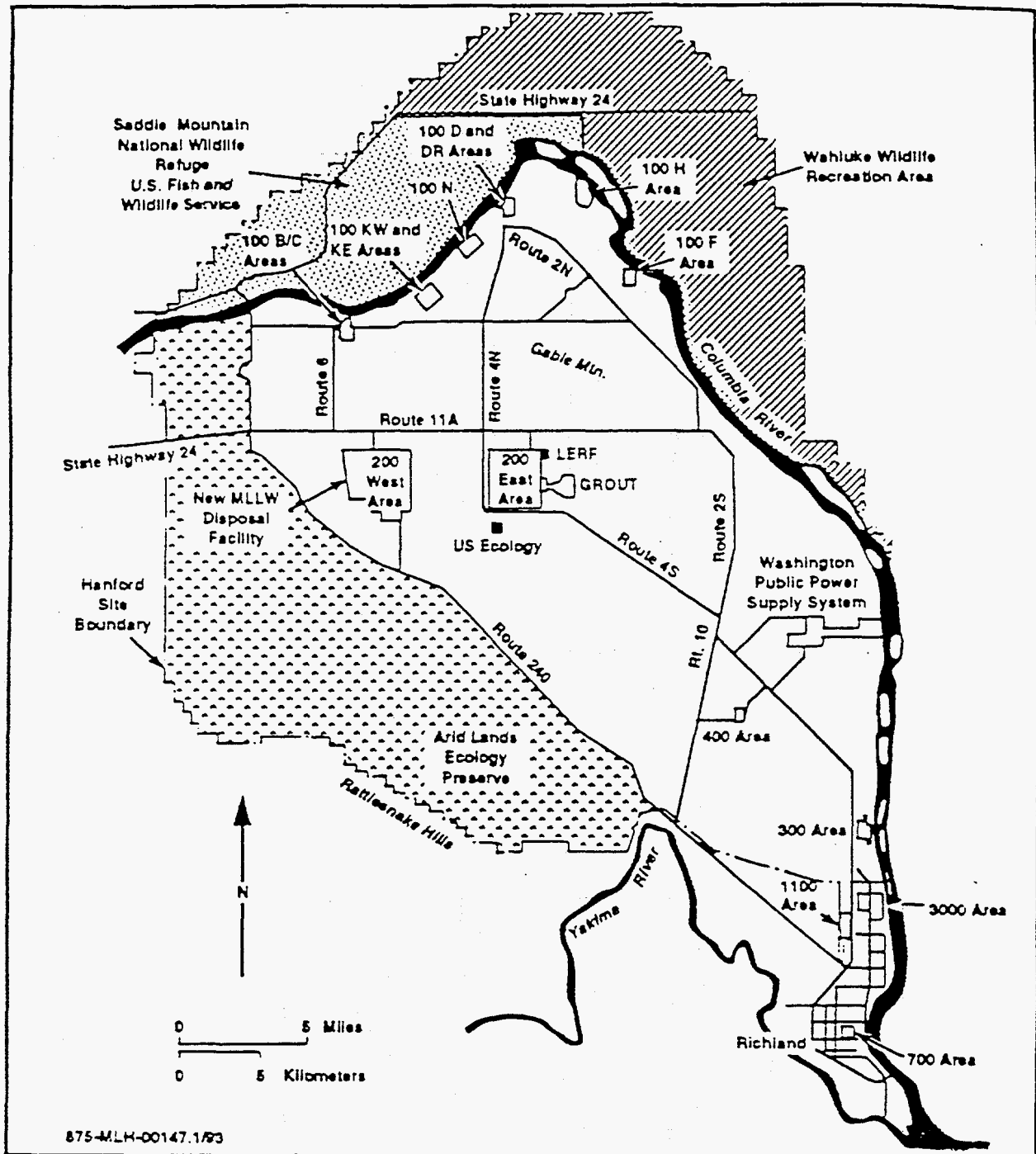

Figure B-27. Location of the proposed mixed waste disposal facility within the 200 West Area at the Hanford Site.

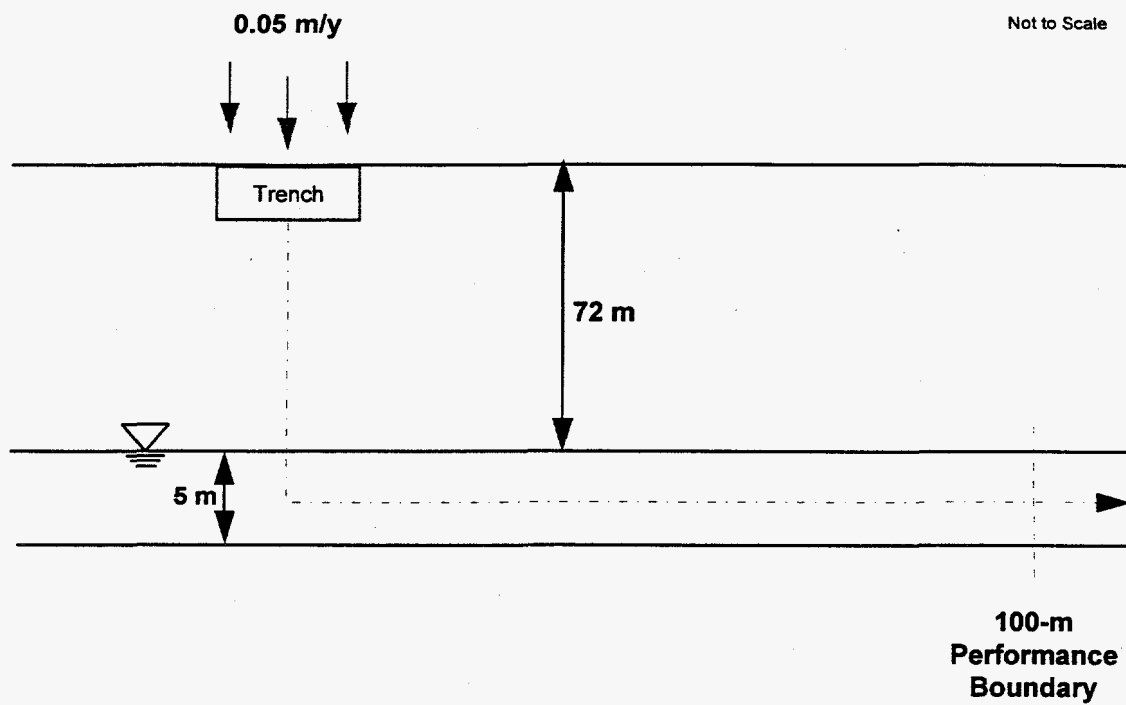

Figure B-28. Conceptual model for the water pathway at Hanford.

Table B-27. Site-Specific Parameters and Values Used in the Scoping Evaluation for the Water Pathway at the Hanford Site (generic values are listed in Chapter 2)

Parameter	Value	Data Type*	Comments
UNSATURATED ZONE			
Natural recharge through local soils, i	0.05 m/y	A	Wood et al., 1994
Moisture content, θ_w	0.09	C	Selected by staff as representative of the unsaturated zone and used to calibrate travel times to the performance assessment; confirmed by Wood (1995).
Bulk density, ρ_b	1.5 g/mL	C	Selected by staff as representative of the unsaturated zone and used to calibrate travel times to the performance assessment; confirmed by Wood (1995).
Distribution coefficients for geologic media, K_d			
As, Cr, Hg, Ag	Various		Default values; see Table 2-5
Ba	1 mL/g	A	Wood et al., 1994
Cd	100 mL/g	A	Wood et al., 1994
Pb	100 mL/g	A	Wood, 1995
Se	0	A	Wood et al., 1994
Thickness between trench and saturated zone, l_v	63 m (207.3 ft)	A	Cumulative unsaturated sediment thickness is 72 m (Wood et al., 1994) and trench facility bottom is 9 m below ground surface
SATURATED ZONE			
Porosity, n	0.31	A	Wood et al., 1994
Bulk density, ρ_b	1.6 g/mL	A	Wood et al., 1994
Distribution coefficients for geologic media, K_d			
As, Cr, Hg, Ag	Various		Default values; see Table 2-5
Ba	1 mL/g	A	Wood et al., 1994
Cd	100 mL/g	A	Wood et al., 1994
Pb	100 mL/g	A	Wood, 1995
Se	0	A	Wood et al., 1994
Mixing depth, d_m	5 m	C	Khaleel, 1995
Darcy velocity, q_{gw}	22 m/y	C	Khaleel, 1995

* A=site measurement; B=result of site numerical analysis; C=literature value selected by the site

B.15.2 Results of the Scoping Evaluation

Application of the methodology outlined in Chapter 2 produced the results shown in Table B-28. The table shows a maximum concentration in treated MLLW (C_{Waste}) and travel time to the performance boundary for each hazardous metal as well as the values used in calculating these results.

In the analysis, the attenuation that occurred between the waste in the disposal facility and the performance boundary was represented by the product of the CRF_{Source} and the CRF_{Water} . For the 8 hazardous metals listed in Table B-28, the total CRF ranged from about 140 to 12,000.

The travel time of water from the disposal facility to the 100-m performance boundary was calculated as a basis for comparison with the retarded travel time of the hazardous metals. For Hanford, water travel time from the land surface to the performance boundary (i.e., without consideration of a disposal facility) was estimated at about 130 y. Of that time, travel time in the saturated zone was about one year.

Based on the results of the scoping analysis, the following observations can be made about disposal at Hanford of hazardous metals contained in treated MLLW:

- Calculated maximum leachate concentrations for 5 of the 8 hazardous metals are greater than the solubilities of the associated metals. These metals are considered to have unlimited values for C_{Waste} .
- Of the 3 hazardous metals that are not solubility limited, selenium has the smallest value for C_{Waste} (0.6 mg/kg) and cadmium the largest (50 mg/kg).
- For selenium, chromium, and cadmium, the 3 metals that are not solubility limited, calculated travel times to the performance boundary are 110 y, 130,000 y, and 190,000 y, respectively. Travel time through the unsaturated zone accounts for almost all of the total subsurface travel time.

Table B-28. Results of Calculations for the Water Pathway at Hanford

Hazardous Metal	Maximum Allowable Concentration in Groundwater, C_{Water}	CRF_{Source}	CRF_{Water}	Maximum Leachate Concentration, C_L	Solubility ^a	Maximum Concentration in Treated MLLW, C_{Waste}^b	Travel Time to Performance Boundary		
							Unsaturated (Vadose) Zone	Saturated Zone	Total
							(y)	(y)	(y)
Arsenic (As)	0.05	27	45	2.3E+00	3.0E-01	NL	1.1E+04	4.5E+01	1.1E+04
Barium (Ba)	1	27	45	4.5E+01	1.8E+00	NL	2.0E+03	8.7E+00	2.0E+03
Cadmium (Cd)	0.01	270	45	4.5E-01	8.0E-01	5E+01	1.9E+05	7.3E+02	1.9E+05
Chromium (Cr)	0.05	27	45	2.3E+00	2.1E+04	3E+01	1.3E+05	5.1E+02	1.3E+05
Lead (Pb)	0.05	270	45	2.3E+00	8.0E-01	NL	1.9E+05	7.3E+02	1.9E+05
Mercury (Hg)	0.002	27	45	9.0E-02	9.0E-03	NL	1.9E+05	7.3E+02	1.9E+05
Selenium (Se)	0.01	3.2	45	4.5E-01	2.8E+06	6E-01	1.1E+02	1.4E+00	1.1E+02
Silver (Ag)	0.05	3.2	45	2.3E+00	7.0E-01	NL	1.7E+05	6.6E+02	1.7E+05

a The solubility of the metal in a selected hazardous metal compound in groundwater (see Section 2.3.3)

b NL means "no limit": the maximum leachate concentration is greater than the solubility of the metal

B.16 References

- ANLE (Argonne National Laboratory—East), 1993. "Statement of Work for a Sitewide Hydrogeological Baseline/ Characterization Study (Phases I and II)." Argonne, IL: Environment and Waste Management Program, Argonne National Laboratory. (unpublished)
- ASI, 1993. *Final Interim Report, Ground-Water Recharge Study*. Lakewood, CO.
- Battelle Columbus, 1995. *Environmental Information Document, Draft-Revision 2*. Columbus, OH.
- Battelle Pantex, 1994. *Fate and Transport Integration Study for Pantex Plant and Vicinity, Draft Report*. Amarillo, TX: Environmental Restoration Department.
- Bergeron, M.P., W.M. Kappel, and R.M. Yager, 1987. *Geohydrologic Conditions at the Nuclear Fuels Reprocessing Plant and Waste-Management Facilities at the Western New York Nuclear Service Center, Cattaraugus County, New York*. USGS Report 85-4145. Ithaca, NY: U.S. Geological Survey.
- Brookins, D.G., 1984. *Geochemical Aspects of Radioactive Waste Disposal*. New York: Springer-Verlag. 347 p.
- Broxton, D.E., S.L. Reneau, and D.T. Vaniman, 1994. *Surficial and Bedrock Stratigraphy at Proposed MWDF*. Unpublished report. Los Alamos, NM: Los Alamos National Laboratory, Geology and Geochemistry Group.
- Campbell, J., 1995. Personal communications with J.C. Wang (ORNL) by facsimile on April 30, 1995, and by telephone on May 2, 1995.
- Carpenter, D. (Lawrence Livermore National Laboratory), 1994. Personal communication with Bruce Thomson (Civil Engineering Department, University of New Mexico). February 18.
- Case, M.J., et al., 1990. *Radioactive Waste Management Complex Performance Assessment*. EGG-WM-8773.
- Chu, M.S.Y., M.W. Kozak, J.E. Campbell, and B.M. Thompson, 1991. *A Self-Teaching Curriculum for the NRC/SNL Low-Level Waste Performance Assessment Methodology*. NUREG/CR-5539, SAND90-0585. Albuquerque, NM: Sandia National Laboratories.
- Conrad, Stephen H., 1993. "Using Environmental Tracers to Estimate Recharge through an Arid Basin," presented at *1993 International High-Level Radioactive Waste Management Conference*, Las Vegas, NV, April 26-30, 1993.

- CRC (Chemical Rubber Company), 1981. *CRC Handbook of Chemistry and Physics*. Eds. Robert C. Weast and Melvin J. Astle. Boca Raton, FL: CRC Press, Inc.
- CRC (Chemical Rubber Company), 1987. *Handbook of Tables for Applied Engineering Science, 2nd edition*. Eds. Bolz R.E., and G.L. Tuve. Boca Raton, FL: CRC Press, Inc.
- Davis, K.R., 1995a. Personal communication as electronic mail to J.C. Wang (ORNL) dated May 2, 1995.
- Davis, K.R., 1995b. Memorandum to LLW Repository Files, dated April 6, 1995.
- Detty, T.E., D.P. Hammermeister, D.O. Blout, M.J. Sully, R.L. Dodge, J. Chapman, and S.W. Tyler, 1993. "Water Fluxes in a Deep Arid-Region Vadose Zone," Abstract in *Proceedings of the 1993 Fall Meeting, American Geophysical Union*. Supplement to *Eos*, October 26, 1993.
- DOE (U.S. Department of Energy), 1995. *Feasibility Study Report for Operable Unit 5*. Fernald, OH: U.S. Department of Energy, Fernald Office.
- EG&G Rocky Flats Inc., 1993. *Site-Wide Groundwater Flow Modeling at the Rocky Flats Plant*. Golden, CO.
- EG&G Rocky Flats Inc., 1995. *Draft Final Hydrogeologic Characterization Report*. Volume II. Golden, CO.
- Fedors, R., and J.W. Warner, 1993. *Characterization of Physical and Hydraulic Properties of Surficial Materials and Groundwater/Surface Water Interaction Study at Rocky Flats Plant, Golden, CO*. Groundwater Technical Report #21. Ft. Collins, CO: Colorado State University.
- Ferry, R. (Weiss Associates), 1994. Personal communication with Bruce Thomson (Civil Engineering Department, University of New Mexico), February 27.
- Freeze, R.A., and J.A. Cherry, 1979. *Groundwater*. Prentice-Hall, Inc. 604 p.
- G&M (Geraghty and Miller), 1989. "Site-Wide Ground-Water Flow Model of the Portsmouth Gaseous Diffusion Plant, Piketon, Ohio." Dublin, OH: Geraghty & Miller, Inc.
- G&M (Geraghty and Miller), 1994. "Quadrant I, RFI Draft Final Report for the Portsmouth Gaseous Diffusion Plant, Piketon, Ohio." Dublin, OH: Geraghty & Miller, Inc.
- G&M (Geraghty and Miller), 1995. "Phase I Hydrogeological Assessment Report, Argonne, Illinois." Milwaukee, WI: Geraghty & Miller, Inc. (unpublished)

- GeoTrans, Inc., 1990. *Numerical Modeling of the Groundwater Flow at the Paducah Gaseous Diffusion Plant, Phase III—Calibrated Three-Dimensional Groundwater Flow Model, Final Report*. Sterling, VA: GeoTrans, Inc.
- Golchert, N.W., 1994. *Surveillance of Site A and Plot M, Report for 1993*. ANL-94/9. Argonne, IL: Argonne National Laboratory.
- Hurr, R.T., 1976. *Hydrology of a Nuclear-processing Plant Site, Jefferson County, Colorado*. USGS Open File Report 76-268.
- Khaleel, R., 1995. Personal communication with J.D. Tauxe, Oak Ridge National Laboratory, Oak Ridge Tennessee, January 13, 1995.
- Knowles, Doyle B., W.J. Drescher, and E.F. LeRoux, 1963. *Ground-Water Conditions at Argonne National Laboratory, Illinois, 1948-60*. Geological Survey Water-Supply paper 1669-0. Washington, DC: U.S. Geological Survey.
- Krynine, Dimitri, and William R. Judd, 1957. *Principles of Engineering Geology and Geotechnics*. New York, NY: McGraw-Hill Book Company.
- LANL (Los Alamos National Laboratory), 1992. *Installation Work Plan for Environmental Restoration*. Report LA-UR-92-3795. Los Alamos, NM: Los Alamos National Laboratory.
- Law Engineering, 1982. *Final Report, Soil and Groundwater Investigations for the GCEP Landfill Pathways Analysis*. Project No. 811049. Denver, CO: Law Engineering Testing Co.
- Madrid, V., 1992. "Neutron Logging at Site 300," interdepartment memo to Site-Wide Remediation Investigation staff. Livermore, CA: Lawrence Livermore National Laboratory. (10/16/92)
- Maheras, Steven J., Arthur S. Rood, Swen O. Magnuson, Mary E. Sussman, and Rajiv N. Bhatt, 1994. *Radioactive Waste Management Complex Low-Level Waste Radiological Performance Assessment*. EGG-WM-8773. Idaho Falls, ID: U.S. Department of Energy Office of Environmental Restoration and Waste Management, DOE Idaho Operations Office.
- MMES (Martin Marietta Energy Systems), EG&G Idaho, Inc., and Westinghouse Savannah River Company, 1994. *Radiological Performance Assessment for the E-Area Vaults Disposal Facility (U)*. WSRC-RP-94-218, Rev. 0. Aiken, SC: Westinghouse Savannah River Company.
- Nyhan, J.W., B. Drennon, and T.E. Hakonson, 1989. *Field Evaluation of Two Shallow Land Burial Trench Cap Designs for Long-Term Stabilization And Closure of Waste Repositories at Los Alamos, New Mexico*. LA-11281-MS. Los Alamos, NM: Los Alamos National Laboratory.

- ORNL (Oak Ridge National Laboratory), 1994. *Performance Assessment for Continuing and Future Operations at Solid Waste Storage Area 6*. ORNL-6783. Oak Ridge, TN: U.S. Department of Energy, Oak Ridge National Laboratory.
- Purtymun, W.D., 1984. *Hydrologic Characteristics of the Main Aquifer in the Los Alamos Area: Development of Ground Water Supplies*. LA-9967-MS. Los Alamos, NM: Los Alamos National Laboratory.
- Raber, Ellen, and David W. Carpenter, eds., 1983. *An Evaluation of the Hydrogeology and Groundwater Chemistry Associated with Landfills at LLNL's Site 300*. UCRL-53416. Livermore, CA: Lawrence Livermore National Laboratory.
- REECo (Reynolds Electrical and Engineering Co.), 1993. *Hydrological Data for Science Trench Boreholes at the Area 5 Radioactive Waste Management Site, Nevada Test Site, Nye County, Nevada*. Las Vegas, NV: Special Projects Section, Environmental Restoration & Technology Development Section, Environmental Management Division, Reynolds Electrical and Engineering Co., Inc.
- REECo (Reynolds Electrical and Engineering Co.), 1994. *Site Characterization and Monitoring from Area 5 Pilot Wells, Nevada Test Site, Nye County, Nevada*. DOE/NV/11432-74. Las Vegas, NV: Special Projects Section, Environmental Restoration & Technology Development Section, Environmental Management Division, Reynolds Electrical and Engineering Co., Inc.
- Rogers, D.P., and B.M. Gallaher, 1994. "Unsaturated Hydraulic Characteristics of the Bandelier Tuff." Los Alamos National Laboratory Memorandum ESH-18/WQ&H-94-525, October 31, 1994.
- Rood, A.S., et al. 1994. *Engineering Design File*, RWMC-760, Idaho National Engineering Laboratory, EG&G Idaho, Inc., Idaho Falls, ID.
- Shaia, G., 1995. Personal communication as electronic mail to Greg Zimmerman (ORNL) dated March 27, 1995.
- SNL (Sandia National Laboratories), 1994. *Sitewide Hydrogeologic Characterization Program, Calendar Year 1993 Annual Report*. Albuquerque, NM: Sandia National Laboratories, Environmental Restoration Program.
- SNL (Sandia National Laboratories), 1995a. *Sitewide Hydrogeologic Characterization Program, Calendar Year 1994 Annual Report*. Albuquerque, NM: Sandia National Laboratories, Environmental Restoration Program.
- Strong, (INTERA), 1995. Personal communication with Alva Parsons (SNL), March 1995.
- Taylor, D., 1994. Personal communication in meeting with INEL site experts, September 23, 1994.

- Turin, H.J., and N.D. Rosenberg, 1994. *Summary of TA-67 Geology, Hydrogeology, and Seismicity for Radiological Performance Assessment-FY93 Report*. LA-UR-94-4399. Los Alamos, NM: Los Alamos National Laboratory.
- USGS (U.S. Geological Survey), 1979 (photo inspected), 1974 (photo revised). "Piketon, Ohio Quadrangle - Pike County 7.5 Minute Series Topographic Map," AMS 4362 II SE-Series V852, Reston, VA: U.S. Geological Survey.
- Waters, Robert D., and Marilyn M. Gruebel, eds., 1996. *Performance Evaluation of the Technical Capabilities of DOE Sites for Disposal of Mixed Low-Level Waste—Volume 3: Site Evaluations*. DOE/ID-10521/3. Idaho Falls, ID: U.S. Department of Energy, Office of Waste Management (EM-30).
- Waters, Robert D., Marilyn M. Gruebel, Maryann B. Hospelhorn, Alva M. Parsons, Bruce M. Thomson, Margaret S.Y. Chu, Gregory P. Zimmerman, John D. Tauxe, Douglas A. Lombardi, Maria L. Socolof, James C. Wang, David Kocher, and Donald W. Lee, 1996. *Performance Evaluation of the Technical Capabilities of DOE Sites for Disposal of Mixed Low-Level Waste—Volume 2: Technical Basis and Discussion of Results*. DOE/ID-10521/2. Idaho Falls, ID: U.S. Department of Energy, Office of Waste Management (EM-30).
- Webster-Scholten, C.P., ed., 1994. *Final Site-Wide Remedial Investigation Report, Lawrence Livermore National Laboratory Site 300*. 15 volumes. UCRL-AR-108131. Livermore, CA: Environmental Restoration Division, Lawrence Livermore National Laboratory.
- Winter, G., and A.H. Nilson, 1979. *Design of Concrete Structures*. Ninth Edition. New York, McGraw-Hill Book Company.
- Wolfsberg, K., 1980. "Sorptive Properties of Tuff and Nuclide Transport Retardation," *Evaluation of Tuff as a Medium for Nuclear Waste Repository: Interim Status Report on the Properties of Tuff*. Eds. J.K. Johnstone and K. Wolfsbert. SAND80-1464. Albuquerque, NM: Sandia National Laboratories. Pp. 39-48.
- Wood, M. W., 1995. Personal communication with John Tauxe (ORNL) on December 20, 1994, and January 10, 1995.
- Wood, M. W., R. Khaleel, P. D. Rittman, A. H. Lu, S. H. Finfrock, R. J. Serne, K. J. Cantrell, T. H. DeLorenzo, 1994. *Performance Assessment for the Disposal of Low-Level Waste in the 200 West Area Burial Grounds*, WHC-EP-0645, prepared for the U. S. Department of Energy, Office of Environmental Restoration and Waste Management by Westinghouse Hanford Company, Richland, Wash.
- Wood, W.W., and W.E. Sanford, 1995. "Chemical and Isotopic Methods for Quantifying Ground-Water Recharge in a Regional, Semiarid Environment," *Ground Water*. V. 33, pp. 458-468.

WVNSC, Inc. (West Valley Nuclear Services Company, Inc.), 1993a. *Environmental Information Document, Volume III, Part 4, Groundwater Hydrology and Geochemistry*, WVDP-EIS-009, February 1993.

WVNSC, Inc. (West Valley Nuclear Services Company, Inc.), 1993b. *Environmental Information Document, Volume III, Part 5, Vadose Zone Hydrology*, WVDP-EIS-009, February 1993.

WVNSC, Inc. (West Valley Nuclear Services Company, Inc.) and Dames and Moore, 1994. *West Valley Demonstration Project Site Environmental Report Calendar Year 1993*. Prepared for the Department of Energy Idaho Operations Office and West Valley Project Office, West Valley, NY.

DISTRIBUTION

National Governors Association State Task Force Representatives

John Thomasian
NGA-Natural Resources Policy Studies
444 N. Capitol Street, Suite 267
Washington, DC 20001

Gordon Appel
Department of Nuclear Safety
1035 Outer Park Drive, 5th Floor
Springfield, IL 62704

Janice Archuleta
New Mexico Environment Dept.
Hazardous & Radioactive Materials Div.
P. O. Box 26110
Santa Fe, NM 87502

Ann Beauchesne
NGA-Natural Resources Policy Studies
444 N. Capitol Street, Suite 267
Washington, DC 20001-1512

Jerry Boese
Ross & Associates, Ltd.
1218 Third Avenue, Suite 1207
Seattle, WA 98101

Jeff Breckel
Washington Department of Ecology
Nuclear & Mixed Waste Mgmt. Prog.
P. O. Box 47600
Olympia, WA 98504-7600

Boyd Deaver
Pantex Project Manager
TX Natural Resource Conservation Comm.
3918 Canyon Drive
Amarillo, TX 79109

Fred Dowsett
Colorado Dept. of Health
HMWMD-HWC-B-2
4300 Cherry Creek Drive
Denver, CO 80222-1530

Benito Garcia
New Mexico Environment Dept.
Hazardous & Radioactive Materials Bureau
P. O. Box 26110
Santa Fe, NM 87502

Jacqueline Hernandez-Berardini
Colorado Dept. of Public Health &
Environment
4300 Cherry Creek Drive, South/OE-EIG-B2
Denver, CO 80222-1530

Ed Kelley
New Mexico Environment Dept.
Water and Waste Management Div.
P. O. Box 26110
Santa Fe, NM 87502

Earl Leming
TN Dept. of Environment & Conservation
761 Emory Valley Drive
Oak Ridge, TN 37830-7072

Paul Liebendorfer
Nevada Division of Environmental Protection
123 W. Nye Lane
Carson City, NV 89710

Randall McDowell
KY Natural Resources & Environ. Protection
Waste Legal Branch/Dept. of Law
Capitol Plaza Tower, 5th Floor
Frankfort, KY 40601

Dan Miller
Colorado Dept. of Law
Natural Resources Section
1525 Sherman Street
Denver, CO 80203

Graham Mitchell
Ohio Environmental Protection Agency
401 East Fifth Street
Dayton, OH 45402

Brian Monson
Division of Environmental Quality
1410 North Hilton
Boise, ID 83706-1290

Roger Mulder
Texas State Energy Conservation Office
P. O. Box 13047
Austin, TX 78711

Roger Murphy
Dept. of Environmental Conservation
50 Wolf Road, Rm. 460
Albany, NY 12233-7252

Tom Ortziger
Illinois Dept. of Nuclear Safety
1035 Outer Park Drive, 5th Floor
Springfield, IL 62704

Rensay Owen
Idaho State Div. Of Env. Quality
LDR Section
900 N. Skyline, Suite B
Idaho Falls, ID 83402

Mike Savage
Ohio Environmental Protection Agency
P. O. Box 1049
Columbus, OH 43216-1049

Jeff Schrade
Office of the Governor
Division of Environmental Oversight
1410 North Hilton
Boise, ID 83706-1255

Michelle Sherritt
Dept. of Health & Environment
2600 Bull Street
Columbia, SC 29201

John Walker
Agency for Nuclear Projects
1820 N. Carson Street, Suite 252
Carson City, NV 89710

David Wilson
SC Dept. of Health & Environmental Control
2600 Bull Street
Columbia, SC 29201

Mike Wilson
Waste Management Program
Washington Department of Ecology
P. O. Box 47600
Olympia, WA 98504-7600

Tom Winston
Ohio Environmental Protection Agency
401 East Fifth Street
Dayton, OH 45402

Doug Young
Office of the Governor
136 State Capitol Building
Denver, CO 80203

Disposal Workgroup

Joel Case
DOE/Idaho
850 Energy Drive, MS 1118
Idaho Falls, ID 83401-1563

Marty Letourneau
DOE/HQ, EM-35
Trevion II, Room 314
19901 Germantown Road
Germantown, MD 20874-1290

Maurice Ades
WSRC
Bldg. 705-3C
Aiken, SC 29803

Bill Gilbert
DOE/Oak Ridge
P. O. Box 2001
Oak Ridge, TN 37831-8620

Carol Irvine
DOE/Oakland Operations Office
1301 Clay Street, 700-N
Oakland, CA 94612-5208

Jeff Kerridge
DOE/RF
P. O. Box 928
Golden, CO 80402

Lance Mezga
LMES/Oak Ridge
P. O. Box 2003, MS 7357
Oak Ridge, TN 37831-7357

Colleen O'Laughlin
DOE/Nevada
P. O. Box 98518
Las Vegas, NV 89193-8518

Jim Orban
DOE/Albuquerque
Waste Management Division
P. O. Box 5400
Albuquerque, NM 87185-5400

Roger Piscitella
LMITCO
P. O. Box 1625, MS 2424
Idaho Falls, ID 83415

Tim Sloan
LANL, TA-54 Area L
P. O. Box 1663, MS J593
Los Alamos, NM 87545

Joanne Steingard
BDM Federal
Bellmeade 3
20300 Century Blvd.
Germantown, MD 20874

Linda Suttora
DOE/HQ, EM-431
Cloverleaf Bldg.
1000 Independence Avenue, SW
Washington, DC 20585-0002

Joe Waring
DOE/RL
P. O. Box 550, MS S7-55
Richland, WA 99352

Senior Review Panel

Dade Moeller
Dade Moeller and Associates, Inc.
147 River Island Road
New Bern, NC 28562

Randall Charbeneau
Center for Research in Water Resources
10100 Burnett Road
Austin, TX 78758

William Dornsife
Commonwealth of Pennsylvania
P. O. Box 8469
Harrisburg, PA 17105

Frank Parker
Vanderbilt University
Box 1596, Station B
Nashville, TN 37235

Vern Rogers
Rogers and Associates Engineering Corp.
P. O. Box 330
Salt Lake City, UT 84110-0330

Kristin Shrader-Frechette
University of South Florida
Environ. Sc./Policy Prog./ Dept. of
Philosophy
107 Cooper Hall
Tampa, FL 33620-5550

Reading Rooms

Nancy Ben
DOE/RF Public Reading Room
3645 West 112th Ave., Front Range CC
Westminster, CO 80030

Nancy Bennett
DOE Public Reading Room
Albuquerque Technical Vocational Institute
4700 Morris, NE
Albuquerque, NM 87111

Janet Fogg
DOE/NV Public Reading Room
3084 S. Highland Drive
Las Vegas, NV 89109

R.F. Heffner
LLNL
Env. Comm. Rel.
P. O. Box 808L-404
Livermore, CA 94550

Paul Lewis
DOE/SR Reading Room
University of SC - Aiken
171 University Pkwy, Gregg-Graniteville Lib.
Aiken, SC 29801

Amy Rothrock
DOE/OR Public Reading Room
55 Jefferson Circle, Room 112
Oak Ridge, TN 37831

Gayla Sessoms
DOE Public Reading Room
Rm. 1E190 HR831
1000 Independence Ave., SW
Washington, DC 20585

Terry Traub
DOE Public Reading Room
100 Sprout Road, Room 130 West
Richland, WA 99352

Kim Tully
Center for Environmental Mgmt. Information
470 L'Enfant Plaza East, SW, Ste. 7112
Washington, DC 20024

Gail Wilmore
DOE/ID Public Reading Room
University Place, 1776 Science Center Dr.
Idaho Falls, ID 83415

Mary Wilson
Miamisburg Sr. Adult Cntr. Reading Rm.
305 East Central Avenue
Miamisburg, OH 45342

Site Technical Contacts

Jim Ampaya
Rockwell Aerospace-Rocketdyne Div.
Mail Code T006
6633 Canoga Avenue
Canoga Park, CA 91303

Gary Baker
Battelle/Pantex
MS 9061
P. O. Box 30020
Amarillo, TX 79177

Ward Best
U.S. DOE
1800 E. 21st Street
Ashtabula, OH 44004

JoAnna Cole
Portsmouth Gaseous Diffusion Plant
Bldg. X7725, MS 7550
3630 US Rte 23 So.
Piketon, OH 45661

Mike Coony
Rust Federal Services-Hanford
MD278/C3103/200W
2355 Stevens Drive
Richland, WA 99352

Bob Griffis
Rocky Mountain Remediation Services
RFETS
Highway 93, T124A
Golden, CO 80402-0464

Dave Hutchison
Lockheed Idaho Technologies Co.
MS 2414
765 Lindsay Blvd.
Idaho Falls, ID 83415-2414

Susan Jahansooz
Lawrence Berkeley Laboratory
MS B75B-101
1 Cyclotron Road
Berkeley, CA 94720

Lawrence Kozoyed
Norfolk Naval Shipyard
Bldg. M-22, 3rd Floor
LSMM@NNSY Code 106.4
Portsmouth, VA 23709-5000

Nancy Lowry
Westinghouse Savannah River Co.
Environmental Protection Dept.
Bldg. 742-A SRS
Aiken, SC 29808

Joey Macy
FERMCO
MS 16-2
7400 Willey Road
Fernald, OH 45030

Elizabeth Matthews
DOE/West Valley
10282 Rock Springs Road
West Valley, NY 14171-1091

Glenn May
Lawrence Livermore National Laboratory
7000 East Avenue, L-621
Livermore, CA 94551

Robert Murphy
Los Alamos National Laboratory
TA 54, MS J593
37 Mesita del Buey
Los Alamos, NM 87545

Derek Pickett
University of Missouri-Columbia
Research Reactor Center
Research Park Drive
Columbia, MO 65211

Angel Rivera
Lockheed Martin Energy Systems
Hwy 58, Bldg. K-0137, MS 7357
Oak Ridge, TN 37831-7357

Steven Schmucker
Battelle Columbus Laboratories
505 King Avenue, Rm 11-1-064
Columbus, OH 43201

Tom Shadoan
LMES/Paducah
5600 Hobbs Road, C-743 T-9
Paducah, KY 42001

Frank Smaltz
DOE/Miamisburg Area Office
1 Mound Road, MS OSW-214
Miamisburg, OH 45342

Nancy Stewart
Argonne National Laboratory-West
EBR II Site
Scoville, ID 83415

Ken Taylor
Ecology and Environment
1500 First Interstate Center
9999 3rd Avenue
Seattle, WA 98104

Glen Todzia
Brookhaven National Laboratory
Bldg. 445
Upton, NY 11973

Jim Wescott
Argonne National Laboratory-East
9700 South Cass Ave., EWM/Bldg. 340
Argonne, IL 60439-4823

DOE EM-30

Mark Frei
Acting Deputy Assistant Secretary for Waste
Management
US DOE, EM-30
1000 Independence Avenue, SW
Washington, DC 20585

Joseph Coleman
Technical Advisor
US DOE, EM-30
Trevion II
19901 Germantown Road
Germantown, MD 20874

Ralph Erickson
Director, EM-32
US DOE
Trevion II
19901 Germantown Road
Germantown, MD 20874

Dick Blaney
Director, EM-33
US DOE
Trevion II
19901 Germantown Road
Germantown, MD 20874

Lynn Wade
Deputy Director, EM-33
US DOE
Trevion II
19901 Germantown Road
Germantown, MD 20874

Patty Bubar
Director, EM-35
US DOE
Trevion II
19901 Germantown Road
Germantown, MD 20874

Jay Rhoderick
Deputy Director, EM-35
US DOE
Trevion II
19901 Germantown Road
Germantown, MD 20874

Jim Turi
Director, EM-36
US DOE
Trevion II
19901 Germantown Road
Germantown, MD 20874

Jim Antizzo
Director, EM-37
US DOE
Trevion II
19901 Germantown Road
Germantown, MD 20874

Kimberly Chaney
Deputy Director, EM-38
US DOE
Trevion II
19901 Germantown Road
Germantown, MD 20874

Policy Coordination Group

Mike Klimas
DOE/Chicago Operations
9800 S. Cass Avenue
Argonne, IL 60439

Dave Osugi
DOE/Oakland
1301 Clay Street, 700-N
Oakland, CA 94612

Bill Prymak
DOE/Rocky Flats Operations Office
P. O. Box 928
Golden, CO 80402-0928

Melda Rafferty
DOE/Portsmouth
P. O. Box 700
Piketon, OH 45661

Rob Rothman
DOE/Miamisburg Area Office
1 Mound Road, MS OSW-214
Miamisburg, OH 45342

T.J. Rowland
DOE/West Valley Demonstration Project
10282 Rock Springs Road
West Valley, NY 14171

Joy Sager
DOE/Oak Ridge Operations Office
3 Main Street
Oak Ridge, TN 37830

John Sattler
DOE/Fernald
P. O. Box 538705
Cincinnati, OH 45253-8705

Virgil Sauls
DOE/Savannah River Operations Office
Road 1A, Bldg. 703-A, Rm. B110
Aiken, SC 29808

Mona Williams
DOE/Albuquerque Operations Office
P. O. Box 5400, WMOSD
Albuquerque, NM 87185-5400

Other

Nick Orlando
US NRC
11545 Rockville Pike
Rockville, MD 20852

Jeanie Foster
23365 Salt Pork Road
Lawrenceburg, IN 47025

Virgil Lowery
US DOE, EM-35
Trevion II
19901 Germantown Road
Germantown, MD 20874

Greg Duggan
US DOE, EM-35
Trevion II
19901 Germantown Road
Germantown, MD 20874

Joe Ginanni
DOE/NV/WMD
2763 So. Highland Drive
Las Vegas, NV 89109

Helen Belencan
US DOE, EM-35
Trevion II, Room 434
19901 Germandtown Road
Germantown, MD 20874-1290

Jenya Macheret
DOE/ID
850 Energy Drive
Idaho Falls, ID 83401

Ron Nakaoka
Los Alamos National Laboratory
P. O. Box 1663, MS E517
Los Alamos, NM 87545

Internal

1 MS 0720 Phil Pohl, 6626
25 MS 0734 Robert Waters, 6472
1 MS 0734 Larry Bustard, 6472
1 MS 0734 Marilyn Gruebel, 6472
1 MS 0734 Brenda Langkopf, 6472
1 MS 1050 Paul Kuehne, 7571
1 MS 1303 Maureen Lincoln, 7573

Unclassified Unlimited Release Documents

1 MS 9018 Central Technical Files, 8940-2
5 MS 0899 Technical Library, 4414
2 MS 0619 Review & Approval Desk, 12690
For DOE/OSTI