

# SANDIA REPORT

SAND97-0443 • UC-1350

Unlimited Release

Printed February 1997

## Cost Analysis of Energy Storage Systems for Electric Utility Applications

DISTRIBUTION OF THIS DOCUMENT IS UNLIMITED *h*

RECEIVED

MAR 28 1997

OSTI

Abbas Akhil, Shiva Swaminathan, Rajat K. Sen

Prepared by  
Sandia National Laboratories  
Albuquerque, New Mexico 87185 and Livermore, California 94550  
for the United States Department of Energy  
under Contract DE-AC04-94AL85000

MASTER

Approved for public release; distribution is unlimited.



Issued by Sandia National Laboratories, operated for the United States Department of Energy by Sandia Corporation.

**NOTICE:** This report was prepared as an account of work sponsored by an agency of the United States Government. Neither the United States Government nor any agency thereof, nor any of their employees, nor any of their contractors, subcontractors, or their employees, makes any warranty, express or implied, or assumes any legal liability or responsibility for the accuracy, completeness, or usefulness of any information, apparatus, product, or process disclosed, or represents that its use would not infringe privately owned rights. Reference herein to any specific commercial product, process, or service by trade name, trademark, manufacturer, or otherwise, does not necessarily constitute or imply its endorsement, recommendation, or favoring by the United States Government, any agency thereof, or any of their contractors or subcontractors. The views and opinions expressed herein do not necessarily state or reflect those of the United States Government, any agency thereof, or any of their contractors.

Printed in the United States of America. This report has been reproduced directly from the best available copy.

Available to DOE and DOE contractors from  
Office of Scientific and Technical Information  
P.O. Box 62  
Oak Ridge, TN 37831

Prices available from (615) 576-8401, FTS 626-8401

Available to the public from  
National Technical Information Service  
U.S. Department of Commerce  
5285 Port Royal Rd  
Springfield, VA 22161

NTIS price codes  
Printed copy: A04  
Microfiche copy: A01

SAND97-0443  
Unlimited Release  
Printed February 1997

COST ANALYSIS OF ENERGY STORAGE  
SYSTEMS FOR ELECTRIC UTILITY  
APPLICATIONS

Prepared By:

Abbas Akhil  
Energy Storage System Analysis and Development Department  
Sandia National Laboratories  
Albuquerque, NM 87185

Shiva Swaminathan  
Rajat K. Sen

R.K. Sen & Associates, Inc.  
4733 Bethesda Avenue  
Suite 608  
Bethesda, MD 20814

**MASTER**

**DISTRIBUTION OF THIS DOCUMENT IS UNLIMITED**

**Abstract**

Under the sponsorship of the Department of Energy, Office of Utility Technologies, the Energy Storage System Analysis and Development Department at Sandia National Laboratories (SNL) conducted a cost analysis of energy storage systems for electric utility applications. The scope of the study included the analysis of costs for existing and planned battery, SMES, and flywheel energy storage systems. The analysis also identified the potential for cost reduction of key components.

---

---

# TABLE OF CONTENTS

---

---

<b>Executive Summary .....</b>	<b>1</b>
<b>1.0 Introduction .....</b>	<b>2</b>
1.1 Approach.....	pieces. 2
1.2 Organization of the Report.....	3
<b>2.0 Overview of Energy Storage Systems &amp; Components.....</b>	<b>4</b>
2.1 Energy Storage Subsystem for BE.....	5
2.2 Energy Storage Subsystem for SMES.....	6
2.3 Energy Storage Subsystem for FES .....	7
2.4 The Power Conversion Subsystem.....	8
2.5 Balance of Plant .....	10
<b>3.0 Applications of Energy Storage Systems.....</b>	<b>11</b>
3.1 Spinning Reserve.....	12
3.2 Generation Capacity Deferral.....	12
3.3 Area/Frequency Control.....	13
3.4 Integration With Renewable Generation.....	13
3.5 Load Leveling .....	13
3.6 Transmission Line Stability.....	13
3.7 Voltage Regulation.....	14
3.8 Transmission Facility Deferral.....	14
3.9 Distribution Facility Deferral.....	14
3.10 Customer Service Peak Reduction .....	14
3.11 Transit System Peak Reduction.....	15
3.12 Reliability, Power Quality, Uninterruptible Power Supply-Small.....	15
3.13 Reliability, Power Quality, Uninterruptible Power Supply-Large.....	15
<b>4.0 Analysis of Storage Demonstration Project Costs.....</b>	<b>17</b>
4.1 Analysis of BES Costs .....	18
4.1.1 Batteries & Accessories .....	18
4.1.2 Power Conversion Systems.....	22
4.1.3 Balance of Plant - System Integration & Facility Development.....	23
4.2 Analysis of SMES Costs .....	24
4.3 Analysis of FES Costs.....	25
4.4 Cost Reduction Potential of Energy Storage Systems.....	26
<b>5.0 Conclusions .....</b>	<b>30</b>
<b>References .....</b>	<b>32</b>



**DISCLAIMER**

**Portions of this document may be illegible in electronic image products. Images are produced from the best available original document.**

## **DISCLAIMER**

**This report was prepared as an account of work sponsored by an agency of the United States Government. Neither the United States Government nor any agency thereof, nor any of their employees, make any warranty, express or implied, or assumes any legal liability or responsibility for the accuracy, completeness, or usefulness of any information, apparatus, product, or process disclosed, or represents that its use would not infringe privately owned rights. Reference herein to any specific commercial product, process, or service by trade name, trademark, manufacturer, or otherwise does not necessarily constitute or imply its endorsement, recommendation, or favoring by the United States Government or any agency thereof. The views and opinions of authors expressed herein do not necessarily state or reflect those of the United States Government or any agency thereof.**

---

---

## **LIST OF APPENDICES**

---

---

Appendix A: Persons Contacted to Obtain Cost Information .....	33
Appendix B: Components of Cost For An Energy Storage System .....	34
Appendix C: Component Cost of BES Projects & Products.....	35
Appendix D: Description of System Components & Applications of Projects.....	40

### **ACRONYMS & ABBREVIATIONS**

A&E	Architectural and Engineering
BES	Battery Energy Storage
EPRI	Electric Power Research Institute
ES	Energy Storage
FES	Flywheel Energy Storage
HVAC	Heating Ventilation and Air Conditioning
kWh	kilo Watt hour
MJ	Mega Joule
PREPA	Puerto Rico Electric Power Authority
RPM	Revolutions Per Minute
SMES	Superconducting Magnetic Energy Storage
UPS	Uninterruptible Power Supply

### **ENERGY CONVERSION UNITS**

1 Mega Joule=0.28 kilo Watt hour

---

---

## LIST OF FIGURES

---

---

Figure 2.1	Main Components of BES.....	5
Figure 2.2	Main Components of a SMES.....	6
Figure 2.3	Cross-Sectional View of the Flywheel Containment Vessel.....	7
Figure 2.4	Power Conversion & Control Subsystem .....	9
Figure 4.1	Capital Cost Learning Curve .....	26

---

---

## LIST OF TABLES

---

---

Table 3.1	Summary of Applications Requirements.....	11
Table 3.2	Suitability of Storage Systems for Utility Applications.....	16
Table 4.1a	Cost of Projects and Products - Energy Storage Systems .....	19
Table 4.1b	Cost of Projects and Products - Power Quality Systems.....	20
Table 4.2	Cost of Batteries & Accessories.....	21
Table 4.3	Normalized Cost of Batteries & Accessories - 1995\$.....	21
Table 4.4	Power Conversion System Costs of BES .....	23
Table 4.5	Industry View of Present & Projected Cost of Energy Storage Systems.....	29

## EXECUTIVE SUMMARY

Energy Storage (ES) systems could potentially have widespread applications within the electric utility industry. Three promising storage technologies - Battery Energy Storage (BES), Superconducting Magnetic Energy Storage (SMES) and Advanced Flywheel Energy Storage (FES) - each meet some of the performance requirements of the 13 utility applications identified in the *Battery Energy Storage for Utility Applications: Phase I - Opportunities Analysis* study conducted by Sandia National Laboratories (SNL). This study estimates the current cost breakdown of ES systems using the three storage technologies, after extensive discussions with system and component suppliers, and identifies the potential for cost reductions in key components.

The current cost of one- to two-hour BES systems ranges from \$1,200-1,500/kW. This cost reflects the typical expenses associated with one-of-a-kind engineered systems. The balance of plant costs account for about 50% of the total, providing the greatest cost reduction potential. The balance of plant expenditures include design, building of a facility to house the equipment, project management, packaging, transportation and system assembly. These costs can be greatly reduced by adopting standardized system designs that favor modular sizing and factory assembly.

Both in terms of performance and cost, BES and SMES are well suited for power quality applications. Fast acting advanced FES also has the potential to serve this application and prototypes have been demonstrated. SMES and FES systems are in early stages of market entry and are expected to primarily serve the customer-end power quality market. All power quality systems are expected to be factory assembled.

For ES applications requiring 1-2 hours of storage, power conversion and control systems (PCS) presently cost ~\$300/kW and are not projected to drop by more than 10 percent. On the other hand, the PCS costs for power quality applications are expected to drop by 25-40 percent. The concept of modular PCS is now being advanced as a way to drive PCS costs down. Modular PCSs are composed of many smaller power converters that are networked in parallel and use software control to achieve the same power rating of a single large converter. Modular PCSs are expected to have better redundancy, reliability, and efficiency as well as lower cost since they can take advantage of mass production of these smaller modules.

The present capital cost structure makes ES systems less competitive for applications that require both high power ratings (MW scale) and long durations (>1 hour). Even with projected cost reductions, storage systems cannot be viewed as competitive for energy supply applications such as load leveling and generation capacity deferral. Rather, with the advent of fast acting power conversion and control systems, coupled with the very fast response of the storage technologies, the three ES technologies are best suited for dynamic system operations.

# COST ANALYSIS OF ENERGY STORAGE SYSTEMS FOR ELECTRIC UTILITY APPLICATIONS

## 1.0 INTRODUCTION

The Opportunities Analysis Study<sup>1</sup> identified 13 different applications for BES systems for electric utility applications. Although the study focused on BES, the results of the study are applicable to other ES systems as well. The two key recommendations that emerged from that study are as follows:

- The need for an assessment to better define the market for ES systems in the electric utility industry.
- The need to develop a standardized cost-breakdown structure for ES systems that would allow one to objectively compare the cost/benefit aspects of various storage technologies.

The first recommendation was implemented when SNL commissioned Frost & Sullivan to conduct a market assessment. The report on that assessment is expected to be complete by late 1996.

This cost analysis study addresses the second recommendation and investigates issues related to the cost-breakdown structure of ES systems. This study specifically addresses the following areas:

- Cost estimates of ES projects (current and planned) in the United States, according to the standardized format proposed in the Opportunities Analysis Study.
- Vendor estimates regarding the potential for cost reductions in the key components for each type of ES system.

Based on the findings of this study, the expectation is that the standardized cost format could be used for estimating and allocating future costs of ES projects, as well as provide a basis for comparing costs of different storage technologies.

### *1.1 Approach*

Cost information on existing or planned ES demonstration projects was solicited for this study from both utility and vendor groups. Appendix A identifies the companies contacted as well as the projects for which information was sought.

The companies contacted were asked to provide cost information according to the standardized format shown in Appendix B. This particular format was chosen since it was the standardized

---

<sup>1</sup> 'Battery Energy Storage for Utility Applications: Phase I - Opportunities Analysis' is a study conducted by Sandia National Laboratories in October 1994. SAND94-2605/UC-212

cost-breakdown format recommended in the Opportunities Analysis Study. It was, however, modified to properly account for the different storage technologies investigated. Initial contact with the utilities and the vendors was made by mail. Subsequent telephone discussions and site visits were conducted to gather more detailed information.

Since most companies consider cost information to be proprietary, each vendor was assured that they would be given an opportunity to review the data to be included in this report prior to its publication. This encouraged the companies to discuss cost issues as openly and candidly as possible. Each vendor was sent a detailed summary of the discussion and was permitted to delete any information they considered to be proprietary.

The quality and quantity of cost information obtained for this report varied greatly depending on the state of the technology (commercial vs. developmental), the status of the specific demonstration projects, as well as the particular vendors. For example, the cost-breakdown of many operational BES projects could be obtained with a great degree of accuracy, while vendors were justifiably reluctant to discuss new or planned projects. While the report presents all the information that was acquired, the emphasis for comparative purposes is on the percentage of cost associated with the following three key components of ES systems:

- Storage Subsystems
- Power Conversion Subsystems (PCS)
- Balance of Plant (BOP)

Vendor estimates on the potential for further cost reductions are presented as a percentage reduction in each of these three categories.

Finally, it must be stated that the discussions held with vendors were limited to those who have participated or are participating in specific ES projects for the electric utility industry and do not represent the views of the entire industry.

## ***1.2 Organization of the Report***

The Executive Summary briefly outlines the findings of this study. Section 1 of the report discusses the objectives of the study and outlines the methodology adopted to conduct it. Section 2 provides an overview of ES technologies and their key components. These key components, including the different energy storage technology subsystems, PCS and the balance-of-plant are described in terms of characteristics and cost drivers. Section 3 discusses performance and correlates the three ES system technologies into the 13 potential applications. Section 4 describes the cost data associated with current demonstration projects as well as the potential for future cost reductions. Finally, Section 5 presents the conclusions that are drawn from the available cost data. Appendices provide detailed project/product cost information, the sources of such information, and a description of each project/product investigated.

## 2.0 OVERVIEW OF ENERGY STORAGE SYSTEMS AND COMPONENTS

ES systems are composed of three key components, namely the storage subsystem, power conversion subsystem, and balance of plant. The three ES systems investigated in this report are Battery Energy Storage (BES), Superconducting Magnetic Energy Storage (SMES) and Flywheel Energy Storage (FES). Among the three, BES is the closest to being available on a commercial scale, followed by SMES, which has been installed at several industrial sites for power quality applications. Low-loss, high-speed FES systems mounted on magnetic bearings, primarily developed for automotive applications, are in the preliminary design and testing stages for utility scale applications.

The storage subsystem for BES consists of battery modules that are connected in series to form strings; and the strings are in turn connected in parallel to provide the required rating for the battery subsystem. Though a variety of battery technologies are available, the most common commercially available technologies for utility applications are flooded lead-acid battery and valve-regulated lead-acid (VRLA) battery. Hardware associated with the installation of these batteries includes interconnects, fuses, racking, protective guards and fire equipment. In addition flooded lead-acid batteries require spill troughs, watering systems and venting. The storage subsystem for a BES is explained in Section 2.1 and the main components of the BES system are illustrated in Fig 2.1.

A SMES storage subsystem consists of a superconducting magnet that stores energy in a magnetic field. This magnetic field is created by the flow of direct current in a coil of superconducting material. The storage subsystem consists of the magnet, leads, enclosure, thermal shield, cryogenics, pumps, vent, and other components. Section 2.2 describes the storage subsystem and its operation, and Fig 2.2 shows the main components of SMES. The storage subsystem of a FES consists of a flywheel that stores kinetic energy by spinning at very high velocities (tens of thousands of revolutions per minute). The FES also consists of the radial and thrust magnetic bearings, center post, containment, and other components. Section 2.3 explains the operation of the flywheel and a schematic configuration of a FES is shown in Fig 2.3.

It is customary for energy stored in magnets to be specified in Mega Joules (MJ) and energy stored in electrochemical batteries and flywheels to be specified in kiloWatt hour (kWh). One MJ is equivalent to 0.28 kWh. This report will use the customary units when discussing each of the technologies, but will use MJ for the three technologies when comparing customer-end power quality system and kWh when comparing all other applications.

The power conversion subsystem for all three energy storage subsystems consists of a combination of rectifier/inverter, transformer, DC and AC switchgear, disconnects, breakers, switches, and programmable high-speed controllers. A high-speed motor/generator set is part of the power conversion system in the FES system. High-speed solid-state transfer switches are used in power quality applications where high switching speeds are a requirement for the ES system. Section 2.4 explains the operation of the PCS.



The control system for ES systems has three main functions. The management and control of storage subsystem monitors the charge level, charge/discharge requirements, and related operations. The controls associated with the PCS subsystem monitors utility power supply and switches the load between the ES system and utility supply according to a predetermined algorithm. The facility control system monitors the temperature, ventilation and lighting in the facility that houses the hardware. Each of these three control systems will be discussed when describing the relevant subsystems they control.

The balance of plant encompasses the facility to house the equipment, heating, ventilation and air conditioning (HVAC), the interface between the ES system and the customer/utility, the provision of services such as data gathering/trending, project management, transportation, permits, training, spares, and finance charges. The cost of the balance of plant is a variable component both between and within the three technologies and, to a large extent, is determined by the needs of specific sites and applications.

### 2.1 Energy Storage Subsystem for BES

A BES system consists of several components as shown in Figure 2.1 below. The main hardware of the system consists of batteries, the PCS and the control system.

Fig 2.1: Main Components of BES system

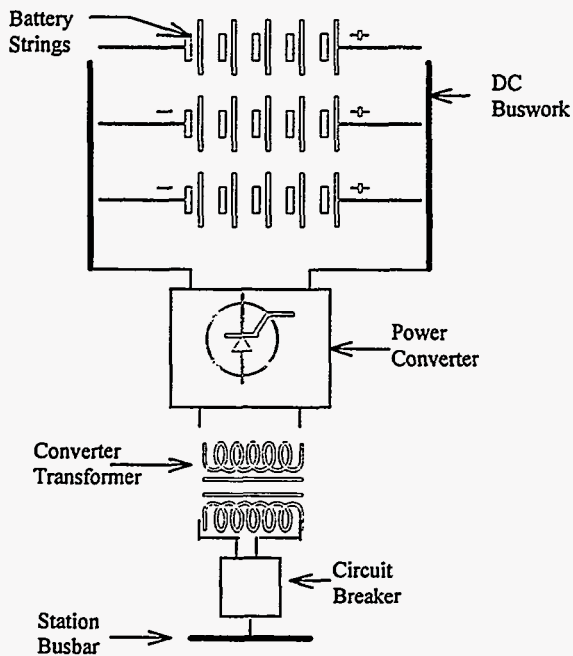

A battery modules' basic building block is the electrochemical cell. At times a number of electrochemical cells are packaged together to form a battery module. The battery modules are connected in a matrix of parallel-series combination to form a string. A string may be formed to deliver the required voltage which may range from a few hundred volts up to approximately 2,000 volts. The string voltage is selected to minimize the power converter and buswork costs.

The life of a battery and its energy delivery capability is highly dependent on the manner in which it is operated. In general, many deep discharges reduce battery life. High rates of discharge reduce the energy delivery potential of the battery. For example, a 1-MW/1-MWh BES discharged

at 1 MW will be able to supply the entire 1 MWh of stored energy over a 1-hour period. However, if discharged at a 2-MW rate, the battery will operate for less than half an hour, delivering less than 1 MWh of energy in the process.

The life of a battery is affected by the manner in which it is operated. The cycle life (the number of charges and discharges it can perform) of a battery is highly dependent on the depth of discharge, with deep discharges (>70-80 percent) significantly reducing its cycle life. Batteries also have shelf-life limitations.

Flooded and valve-regulated lead-acid batteries are two commercially available battery technologies for utility applications. Advanced batteries such as sodium/sulfur (Na/S) and zinc/bromine (Zn/Br) are being developed and may soon be commercially available.

## 2.2 Energy Storage Subsystem for SMES

A Superconducting Magnetic Energy Storage (SMES) System consists of several components as shown in Fig 2.2. Though large SMES systems (10-100 MW, with storage times of minutes) are under development, smaller units (1-10 MW, with storage times in seconds) are becoming commercially available to serve the power quality market. Larger SMES systems are anticipated to store thousands of MJ of energy while the smaller micro-SMES systems are expected to have 1-10 MJ (0.28-2.8 kWh) of energy storage capability.

Figure 2.2: Main Components of a SMES system

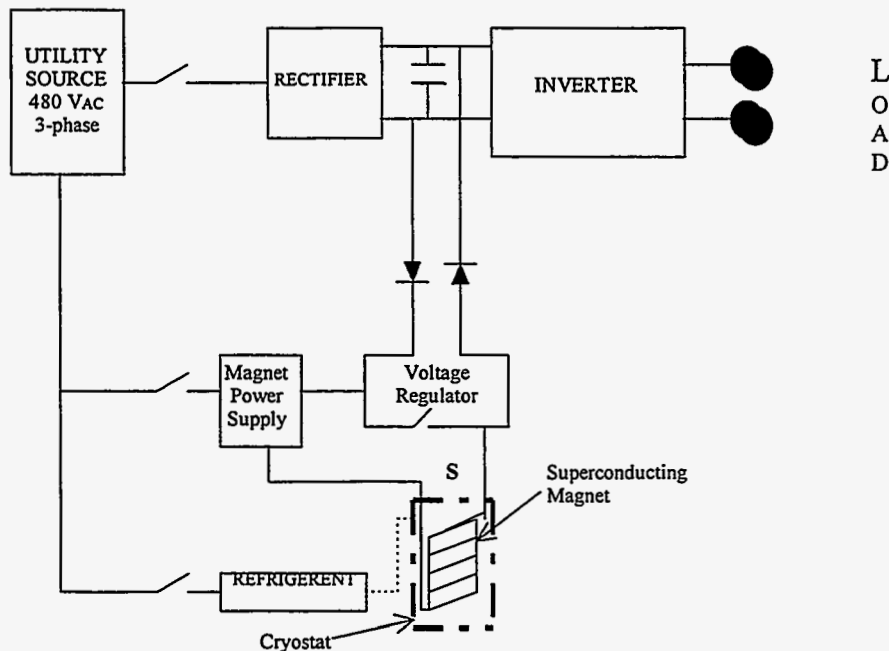

The main hardware of a SMES consists of the magnetic storage unit, the cryostat, and the power conversion system. The superconducting system stores energy in the magnetic field created by the flow of direct current in a coil of superconducting material. To maintain the coil in its superconducting state, it is immersed in liquid helium contained in a vacuum-insulated cryostat. Typically, the conductor is made of niobium-titanium, and the coolant can be liquid helium at 4.2 K, or super fluid helium at 1.8 K. In the standby mode, the current continually

circulates through the normally closed switch 'S', as shown in Fig 2.2. The power supply continuously provides a small trickle charge to replace energy lost in the non-superconducting part of the circuit in the standby mode.

### 2.3 Energy Storage Subsystem for FES

Flywheel Energy Storage (FES) systems are under development primarily for automobile and space applications. Though the concept of flywheels is not new, low-loss flywheels that rotate on magnetic bearings in a levitated state at very high speeds are a relatively new development. The FES for electric utility applications does not have many of the dynamic isolation problems that have to be overcome for automotive applications. Small kW/kWh-scale systems for power quality applications are now available in the commercial market.

The stored energy in flywheels is proportional to the flywheel's moment of inertia multiplied by the square of its angular speed. Therefore, high velocities are required to store large amounts of energy. Flywheels with speeds of tens of thousands of revolutions per minute (RPM), up to 100,000 RPM, have been tested. The flywheel configuration is driven by the need to have the maximum moment of inertia for a given weight. Economics dictate the use of light weight composite materials to withstand the stresses created during the high-speed operation of the flywheel. The use of magnetic bearings and a vacuum chamber helps reduce losses.

Fig 2.3: Cross-Sectional View of the Flywheel Containment Vessel

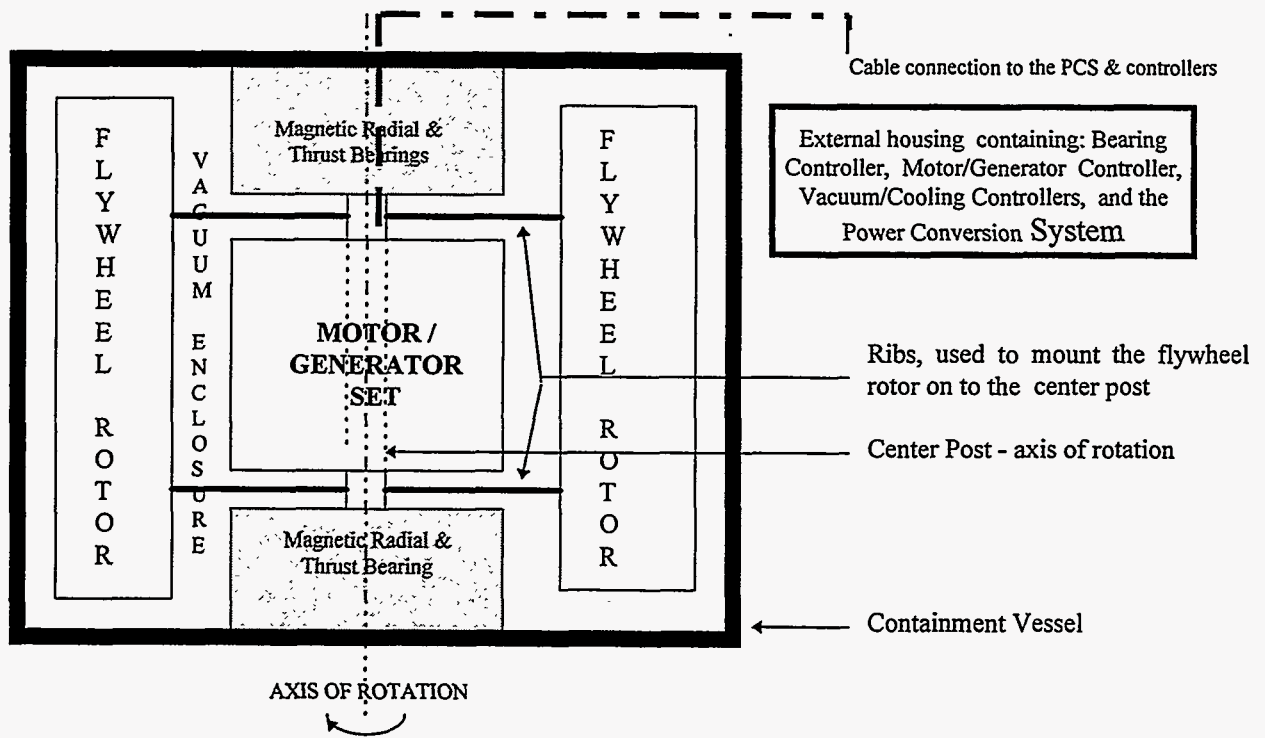

A motor/generator set is mounted on the same center-post as that of the flywheel, and rotates at the same speed as that of the flywheel. The configuration shown in Fig 2.3, has the motor/generator set mounted within the flywheel rotor. The vertical center post rests on

bearings, the entire assembly is enclosed within a vacuum containment vessel. The configuration allows for compactness and reduction of rotational losses. The electrical leads from the motor/generator set is brought out of the vacuum containment and connected to PCS. The controllers of the motor/generators, bearings, vacuum/cooling system, the PCS and its controllers are all housed outside the containment.

A FES system can be optimized either for power or energy. Large power ratings require large motor/generators, which themselves have the ability to store large amounts of kinetic energy because of their large mass and high rotational speeds. Optimization for energy will require relatively larger flywheels to store energy, since the smaller-sized motor/generator (smaller power rating) will not be able to store large amounts of energy. The motor/generator housed within the flywheel is typically a permanent magnet, brushless, dc drive commutated electronically. The dc-voltage output of the motor/generator set has to be conditioned by a typical power conversion system to interface with the external supply and load.

Stress/strain cycles are created in the flywheel as the velocities change. In order to maintain constant voltage as the speed varies and to reduce these stress/strain cycles the system is not allowed to slow down completely. It is similar in concept to electrochemical batteries where a high depth of discharge reduces the life of the battery. The thrust bearings of FES systems will also have to be periodically replaced.

#### ***2.4 Power Conversion Subsystem***

The power conversion subsystem used by all three storage technologies operate under the same principle. The power converter consists of a combination of rectifier/inverter and a transformer where needed. When the storage subsystem is being charged, the converter behaves like a rectifier, changing the ac voltage into dc. When discharged, or when it is supplying power to the system, the converter operates as an inverter.

In the rectifier mode the converter controls the voltage and the charging current. The voltage and the resulting current are adjusted for the desired charge rate. The conversion of ac voltage to dc is achieved by firing the thyristors so that the voltage from the transformer windings cause the desired current to flow to the storage subsystem. In the inverter mode, the converter essentially chops the dc current into segments and builds a voltage wave that is an approximation of the normal ac system sine wave.

The converter causes power to flow into the ac bus by shifting its waveform (the ac waveform created from the dc-bus voltage) ahead of the waveform of the bus voltage. Reactive power is delivered by making the magnitude of the waveform larger than that of the ac-bus voltage.

Converters are normally given ratings in MVA, but this rating only applies at rated voltage. Converters are, in reality, current-limited devices. A converter can be used to provide active or reactive current or a combination within its current handling capability. Because real and imaginary current are in quadrature, the square root of the sum of the squares of the reactive

and active currents must remain within the converter current capability. A 10-MVA converter can thus supply 7 MW/7 MVAR, 8 MW/6 MVAR, 6 MW/8 MVAR, etc. at rated voltage.

The power conversion control is generally divided into two loops. The 'inner loop' provides high-speed regulation of the energy storage subsystem. For instance, if the battery is being controlled to a certain power level, the controller will adjust the thyristor firing pulse so that power is maintained even when the bus voltage varies. The controller will also go into a current control mode when a drop in voltage requires converter current to rise above the converter rating to maintain power. Figure 2.4 illustrates a power conversion and control system.

The inner loop may also include voltage control circuitry. This circuitry adjusts firing pulses to the thyristors so that the converter will produce or absorb reactive current as needed to regulate bus voltage. Again, the controller will go into a current control mode if the thyristor current would have to exceed thyristor rating in order to hold the desired bus voltage. The converter effectively synthesizes a waveform that is either larger or smaller in magnitude than the bus voltage, and either leads or lags the bus voltage. The voltage and power level control circuitry operate simultaneously to control the magnitude and phase of the waveform, respectively.

**Fig 2.4: POWER CONVERSION AND CONTROL SUBSYSTEM**

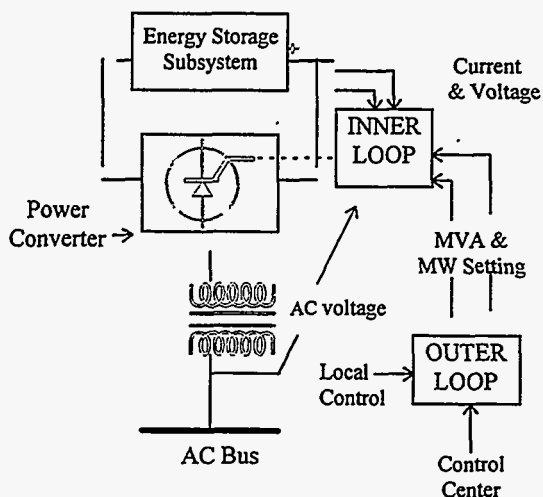

The 'outer loop' control is slower, and typically is a desired power level signal received from the system control center. It could be provided by the automatic generation control system, and could be similar to the raise and lower signals sent to generating plants. It may also be just a time clock that schedules charge and discharge times so as to coincide with system peak load and low load periods, respectively. The outer loop may also include a stabilizer to modulate power when oscillations in line power or frequency occur.

The control system for low-energy, power quality applications of SMES operates as follows: The load, as long as it is receiving power from the storage magnet through the dc-to-ac inverter and coupling transformer, is isolated from the electric utility's faulted system by a fast-acting solid-state switch. The normally closed isolation switch opens when the supply voltage sine wave falls outside a pre-programmed window resident in the system controller. The command to open occurs in fractions of milliseconds after the detection of a fault. When voltage on the capacitor bank on the dc side of the inverter drops during a sag or outage, the normally closed switch opens and current from the coil immediately flows into the inverter. When the voltage across the capacitor bank returns to a preset level, the switch closes. The sequence repeats in rapid succession until normal voltage from the utility feeder is restored. Controls are used to regulate the refrigeration and air-conditioning loads.

In flywheel systems the kinetic energy stored in a flywheel is converted to electrical energy by the generator and is supplied to the loads connected to the FES system. As the energy in the flywheel dissipates, it slows down, but the generator continues to supply constant power until a specified lower speed threshold is reached. Energy is replenished to the flywheel when the motor is connected to the external power source and speeds up to its maximum specified speed, at which point the external power source is disconnected. Controllers are used maintain the vacuum in the containment vessel and the magnetic bearing.

### ***2.5 Balance of Plant***

Balance of plant, as discussed earlier, encompasses the facility to house the equipment, HVAC, and the interface between the ES system and the customer/utility. In addition to buildings and interface equipment, the provision of services, such as data gathering/trending, project management, transportation, permits, training, spares and finance charges add substantial cost to storage systems.

ES systems available at present are not off-the-shelf products (with the exception of some power quality systems), and are custom-sized depending on the needs of each customer. The incidental cost particular to custom-built systems has added considerable cost to each of the systems now in operation. The balance of plant cost for the 20-MW/14-MWh BES at Puerto Rico, consisting of building of the facility, load interface, O&M, services, finance charges and taxation account for 46 percent of the total project cost of \$21.4 million. Building the facility accounted for 22 percent while load interface, O&M, services, finance charges and taxation accounted for 3%, 3%, 9%, and 9% of the total project cost, respectively.

The balance of plant costs of storage systems for power quality applications, on the other hand, are much lower in percentage terms. This could be attributed to uniform off-the-shelf product lines to serve a well defined application. The lower energy storage requirements of power quality systems make them compact and enables the entire system to be housed within a container, making them easier to transport.

The balance of plant for the battery-based PQ2000 product line accounts for 27 percent of the system cost, with load interface, delivery/installation/support, taxes, and services accounting for 5%, 5%, 7%, and 10% of the system cost, respectively. Preliminary estimates for the cost of balance of plant for the SSD<sup>®</sup> product line (a micro-SMES system developed by Superconductivity, Inc.) is estimated to be approximately 40 percent.

Since commercial FES systems are not available, costs associated with balance of plant were not available. An important feature of the FES system is that a separate building will not be necessary, since the flywheel along with its containment vessel, in most instances, will be placed underground. Since the containment is housed below the surface, the cost associated with erecting a building is minimized. However, the power conversion system, the bearing controller, the motor/generator controller, and the vacuum/cooling systems, all have to be housed separately above ground.



### 3.0 APPLICATIONS OF ENERGY STORAGE SYSTEMS

The 13 applications identified by the Opportunities Analysis Report are listed in Table 3.1.

**Table 3.1: Summary of Applications Requirements**

Application	Approximate Power (MW)	Approximate Storage (hours)	Voltage (kVac)	Cycles/year
<b>GENERATION</b>				
Spinning Reserve	10 - 100	0.5	12- 138	20 - 50
Capacity Deferral	10 - 100	2 - 4	12 - 138	5 - 100
Area/Frequency Regulation	10	<1	12 - 138	250
Integration with R34	1	1 - 4	0.48 - 12	250
Renewables				
Load Leveling	100	> 4	69 - 765	250
<b>TRANSMISSION &amp; DISTRIBUTION</b>				
Transmission Line Stability	100	<0.01	69 - 765	100
Voltage Regulation	1 MVAR	<0.25	12 - 34.5	250
Transmission Facility Deferral	10	2 - 4	12 - 138	5 - 20
Distribution Facility Deferral	1	1 - 3	4 - 34.5	30
<b>CUSTOMER SERVICE</b>				
Demand Peak Reduction	1	1 - 2	0.48 - 12	50 - 500
Transit System Peak Reduction	1	1 - 2	0.48 - 2.4	250 - 500
Reliability & Power Quality (<1 MW)	0.1	< 0.25	0.48	<10
Reliability & Power Quality (>1 MW)	1	1 - 2	0.48 - 12	<10

The suitability of each of the three technologies investigated to serve these applications is discussed below. The ability of ES systems to serve a combination of applications simultaneously makes them attractive for electric utility applications.

The present cost structure of the three storage technologies makes them less competitive for applications that require high power (MW scale) for long durations (>1 hour). It is becoming increasingly clear that storage technologies cannot be viewed as energy supply technology, serving applications such as load leveling and generation capacity deferral; the economics are not advantages to operate in such a mode. This trend could be observed in the recent systems built. They have large power ratings, but are designed to operate for durations < 1 hour. Examples include BES systems in PREPA (1994), Vernon (1995), Metlakatla (1996), Golden Valley (planned) and SMES in Anchorage (construction to begin shortly).

Unlike BES systems, the energy available in a SMES system is independent of the discharge rate. This characteristic along with its quick response time (compared to conventional energy supply technologies) makes SMES suitable for applications that require high power in short energy bursts. SMES systems also have high cycle life which makes them more suitable for applications that require constant cycling as well as continuous mode of operation.

The projected capital cost and parasitic loads<sup>2</sup> make SMES less attractive for competitive diurnal storage applications such as generation, transmission, and distribution capacity deferral, load leveling, customer peak reduction and renewable applications. In continuous mode operation, the system is constantly cycled and the parasitic losses are proportionally less. In diurnal storage applications, these parasitic losses are proportionally large, thus reducing overall system efficiency.

Conventional flywheels operating at low speeds (<1,200 RPM<sup>3</sup>) are used at present as load stabilizers to smooth out large power variations exhibited by draglines in coal mines. Insufficient data are available to determine the suitability of high-speed, low-loss FES for diurnal storage cycling, however, power quality systems are becoming available in the market. Some interest has been shown for the use of FES systems in renewable generation applications, and for the installation of MW/kWh-scale FES systems in distribution substations.

Fast-acting power conversion and control systems and the rapid response time of the three storage technologies, makes these storage systems well suited for dynamic system operations. Dynamic operation applications such as spinning reserve, area/frequency regulation, transmission line stability, and voltage regulation typically require power cycles in durations of minutes.

All three technologies also seem to be capable of meeting the technological requirements of customer-end power quality equipment. Based on the above discussion, the suitability of the three technologies to meet each of the 13 application requirements will be examined in detail below.

### ***3.1 Spinning Reserve***

Spinning reserve is the generation capacity that a utility holds in reserve to prevent interruption of service to customers in the event of a failure of an operating generator. Typically this application requires 10-100 MW and < 30 minutes of storage, but storage capability of a few minutes is usually sufficient. The key to serving this application is quick response time, making all three technologies well suited for spinning reserve applications.

The BES plant in PREPA provides spinning reserve for the island electrical grid in Puerto Rico. The quick response time of the BES, enables the system to maintain a smaller spinning reserve capacity. This system, situated at the Sabana Llana substation in Puerto Rico, can simultaneously provide generation reserve during shortages, spinning reserve for system reliability, and voltage regulation. A 1,350-MJ (375-kWh) system is being designed for spinning reserve/frequency support applications. It will be a 30-MVA, 40-second system, and will be tested at Anchorage Municipal Power & Light.

---

<sup>2</sup> The Market Potential for SMES in Electric Utility Applications. An Arthur D. Little Inc. report prepared for Oak Ridge National Laboratory. ORNL/Sub/85-SL889/1. Exhibits 4.1-4.6 & 11.2

<sup>3</sup> FES system installed at the Usibelli Coal Mine, Alaska.



### ***3.2 Generation Capacity Deferral***

Generation capacity deferral is the ability of a utility to postpone the installation of new generating facilities by supplementing the existing facilities with another resource. This application requires 10- to 100-MW capacity for 2-4 hours. An ES system for such applications does not exist and economics will not encourage it for the foreseeable future. Studies by the California Energy Commission estimate a levelized cost of such an application using BES system to be 13.3 cents/kWh<sup>4</sup>.

### ***3.3 Area/Frequency Control***

Area/frequency control is the ability for grid-connected utilities to prevent the unplanned transfer of power between themselves and neighboring utilities, and the ability for isolated utilities to prevent the frequency of the electricity that they produce from deviating too far from 60 Hz. With deregulation, the transfer of power between utilities will be monitored more frequently than at present, and priced appropriately. Growth in this application is foreseeable, however, such applications using storage do not currently exist. All three technologies are well suited to serve this application.

### ***3.4 Integration with Renewable Generation***

Integration with renewable generation refers to the renewable power available during peak utility demand, and available at a consistent level. Power ratings up to 1 MW for 1-4 hours will be necessary to serve this application.

Batteries are being used with solar panels. Rural electrification has used central wind and solar energy facilities to charge batteries for use at homes. However, large grid-connected renewable generation plants at present do not have storage capabilities. The economics of integrating renewable generation sources with storage systems is still under debate. High capital cost and energy consumption by the cryogenic and refrigeration systems in SMES systems might make them less suitable for long-term storage. Application of flywheels for renewable applications is under consideration.

### ***3.5 Load Leveling***

The storage of inexpensive off-peak power for dispatch during relatively expensive on-peak hours is referred to as load leveling. This application will typically have a 100-MW rating for 1-4 hours. Economics at present will preclude the use of the three storage technologies, for reasons outlined in 3.2.

### ***3.6 Transmission Line Stability***

Transmission line stability is the ability to keep all components on a transmission line in sync and prevent system collapse. Ratings of 100+MW for durations in seconds is typical of this application. This application is suited for all three storage technologies, but superconducting

---

<sup>4</sup> Energy Technology Status Report. Draft report 1996. Biennial report issued by the California Energy Commission which includes technology evaluations for more than 200 electric generation, storage, end-user and T&D technologies.

magnets, with their energy availability independent of the discharge rating, is especially attractive for this high power and short energy burst application.

Storage systems are suitable at instances when large load swings occur at customer locations, especially if the local network is weak to support such large swings. The BES at Metlakatla to support the large swings in the sawmill loads and FES at the Usibelli coal mine to support the dragline loads are examples of such applications. The BES at Metlakatla has a 1-MW/1.27-MWh rating. The FES at the Usibelli coal mine is capable of storing 62.5 kWh at a top speed of 1,200 RPM. The motor/generator of the FES at this facility has a continuous rating of 1.8 MW and a 3-second rating of 5.2 MW. During drag line operation at the mine, the load swings as much as 3 MW (peaking at ~6 MW), but lasts for less than 8 seconds.

### ***3.7 Voltage Regulation***

The Opportunities Analysis Study defines voltage regulation as the ability to maintain the voltage at the generation and load ends of a transmission line within 5 percent of each other. This will typically require a 1-MVAR rating for < 15 minutes. This application is suited for all three storage technologies, and the BES system at PREPA, and SMES proposed in Anchorage, are examples.

### ***3.8 Transmission Facility Deferral***

The ability of a utility to postpone installation of new transmission lines and transformers by supplementing an existing facility with another resource is referred to as transmission facility deferral. The capital cost of building storage systems with ratings of 10+ MW for 2-4 hours discourages storage systems for this applications. Situations may arise, however, where transmission bottlenecks may justify the capital cost of large storage systems.

### ***3.9 Distribution Facility Deferral***

Distribution facility deferral is the ability of a utility to postpone installation of new distribution lines and transformers by supplementing existing facilities with another resource. This application will typically require 1 MW of storage for 1-3 hours. A study by PG&E in 1994 concluded a 1-MW 2-hour BES system with a 10-year life at \$700/kW would enable the deferment of 1 substation increase per year. Commonwealth Edison is investigating the use of FES for the same applications, but with a smaller energy storage capacity.

### ***3.10 Customer Service Peak Reduction***

Customer service peak reduction is the storage of off-peak power for a customer to dispatch during the greatest on-peak demand as a method of reducing monthly demand charges. Ratings of 100 kW to 1 MW for 1-2 hours are required for this application. Tariff structure at present makes it uneconomical to use storage systems for this application alone, despite large variations in prices within a given day.

With the introduction of real-time pricing, rates vary widely in any given day, providing the incentive to reduce demand during peak periods. The real-time tariffs in the Southern California Edison service territory are as high as \$3.0/kWh between 2-4 p.m. on a hot summer

day when temperatures exceed 95°F. The overnight tariff on the same hot day is 6.3 cents/kWh. Although the number of such 'hot' days are few in any given year, it illustrates the marginal system costs when the electrical system operates close to its capacity.

Combining power quality applications with customer peak reduction may make storage attractive.

### ***3.11 Transit System Peak Reduction***

Transit system peak reduction is the storage of off-peak power for a transit system to dispatch during rush hour as a way to reduce monthly demand charges and to relieve the utility of a large demand burden. Storage system ratings in 1-MW sizes for 1-2 hours are required. The SDG&E BES system was an example of a transit system peak reduction application. Future economics of the application are debatable; however, at locations where the local grid finds it difficult to support demand spikes at customer facilities, the use of storage may be an attractive option.

### ***3.12 Reliability, Power Quality, Uninterruptible Power Supply - Small Customer***

This application refers to the ability to prevent voltage spikes, voltage sags, and power outages that last for a few cycles (less than one second) to minutes, from causing data and production loss for customers with demands less than approximately 1 MW for durations in minutes. The application is attractive for storage systems. The economies of scale, however, including the ancillary support equipment associated with SMES, makes SMES less attractive for applications with smaller power ratings (in the lower hundreds of kiloWatts). Small (1-100 kW/kWh) FES systems are becoming available in the market.

### ***3.13 Reliability, Power Quality, Uninterruptible Power Supply - Large Customer***

This application refers to the ability to prevent voltage spikes, voltage sags, and power outages that last for a few cycles (less than one second) to minutes, from causing data and production loss for customers with demands more than 1 MW for 1-2 hours. Power quality applications requiring storage durations in seconds are widespread. All three storage systems are well suited for this application. PQ2000 and SSD systems are examples that are presently being commercialized.

Table 3.2 summarizes the suitability of the three technologies for each of the 13 applications.

**Table 3.2: Suitability of Storage Systems for Utility Applications**

(Suitability is based on technological and operating characteristics, and the potential to compete in terms of capital cost with conventional generation technologies in the short/medium term.)

Applications	BES	SMES	FES	Remarks
<b><u>Generation</u></b>				
Spinning Reserve	* * *	* * *	* * *	Suited for the 3 technologies, made possible by fast-acting power electronics. BES and SMES units in operation/under construction for this application.
Capacity Deferral	X	X	X	Uncompetitive because of present capital-cost structure. Economics of SMES at present is for relatively low energy storage levels. FES can be optimized either for power or energy - application requires both.
Area/Frequency Regulation	* * *	* * *	* * *	Quick response time makes storage attractive. BES to serve these applications exist.
Renewable Applications	* *	X	* *	Economics of firming up intermittent renewable generation to supply reliable energy is still under debate. Energy consumption by the cryogenics and refrigeration in SMES makes it unsuitable for long-term (diurnal) storage.
Load Leveling	X	X	X	Uncompetitive because of present capital-cost structure. Large amounts of energy storage for long durations makes SMES uncompetitive at present.
<b><u>Transmission &amp; Distribution</u></b>				
Transmission Line Stability	* *	* * *	* *	BES and SMES units in operation/under construction for this application.
Voltage Regulation	* * *	* * *	* * *	BES and SMES units in operation/under construction for this application.
Transmission Facility Deferral	*	X	X	Requires large energy storage at high power levels, which at present precludes SMES and FES.
Distribution Facility Deferral	* *	X	*	High energy requirements makes SMES uncompetitive. Economics of BES and FES may justify, depending on the site.
<b><u>Customer Service</u></b>				
Demand Peak Reduction	*	X	*	High energy requirement precludes SMES. Present tariff structure makes the application unjustifiable. However, combining it with power quality applications makes it attractive.
Transit System Peak Reduction	* *	* *	* *	BES is built for this application. FES under investigation to be mounted on locomotives.
Reliability & Power Quality (<1 MW)	* * *	* *	* * *	Domain of UPS, where batteries are used. Low power rating makes SMES uncompetitive compared to batteries, because of the ancillary equipment associated with SMES. FES systems becoming available for this market.
Reliability & Power Quality (>1 MW)	* * *	* * *	* * *	All three attractive. As the protection requirements exceed 5-10 seconds, SMES becomes less attractive.

\* Indicates level of attractiveness/suitability, X indicates unsuitability

#### 4.0 ANALYSIS OF STORAGE PROJECT COSTS

The Opportunities Analysis Study recommended a standardized cost breakdown structure for comparing ES project costs for electric utility applications. Utilities and suppliers were contacted to ascertain the costs of projects according to the detailed categories suggested by the Opportunities Analysis Study. The expectation is that this standardized format could be used for future storage projects, and that it could provide a basis for comparison between different storage technologies.

In many instances suppliers were reluctant to reveal detailed costs. In order to maintain supplier confidentiality, detailed costs were aggregated into three categories: the storage subsystem, power conversion subsystem, and the balance of plant. Some of the data collected provides cost breakdown in a percentage form. BES project cost information was obtained for the following projects:

1. The BES system at the Sabana Llana substation in Puerto Rico (PREPA)
2. The BES system at the Chino substation in Southern California (CHINO)
3. The proposed but later postponed BES project in the service territory of Hawaii Electric Light Company (HELCO)
4. The BES system at the lead smelting factory in Vernon, Southern California (VERNON)
5. The BES project in the service territory of Metlakatla Power & Light in Alaska (METLAKATLA)
6. The BES installation at the Crescent Electric Membership Cooperative in Statesville, North Carolina (CRESCENT ELECTRIC)
7. The San Diego Trolley Project in the San Diego Gas and Electric service territory (SDG&E)
8. The BES system at the Berlin Kraft and Licht in Berlin, Germany (BEWAG)

In addition the system costs for the PQ2000 power quality and PM250 BES product lines were obtained. The BEWAG and SDG&E systems are not in operation now, and the HELCO project was never built. The HELCO costs listed are the estimated project costs.

The SSD<sup>®</sup> micro-SMES product line developed by Superconductivity, Inc. has been installed at several facilities, and its cost breakdown is discussed. The cost of the IPQ-750 micro-SMES developed by Intermagnetics General Corporation is also presented. Preliminary cost data for the larger, 1,350-MJ (375-kWh) SMES proposed at Anchorage is also presented.

Small-scale, low-loss (compared to conventional flywheels), high-speed FES systems are expected to be introduced to serve power quality applications. Prices of such systems, as quoted by vendors, and a simplified direct cost estimate developed by a vendor for larger systems are provided. The ratings and operating characteristics of the only operational FES system investigated at the Usibelli coal mine is also discussed.



As outlined in section 2.0, when comparing the three technologies for customer-end power quality applications the energy storage capacity will be specified in MJ, while kWh will be used for all other applications.

Tables 4.1a and 4.1b summarizes the cost of projects and storage system products. Description of projects are summarized in Appendices C and D. The energy storage projects and energy storage products, for which cost details were obtained, are listed in Appendix A along with the source of information. Appendix B lists the standard cost break-down structure developed in the Opportunities Analysis report. The detailed cost breakdown of each of the projects (in nominal dollars) is listed in Appendix C.

#### ***4.1 Analysis of BES Costs***

Appendix D lists the BES demonstration projects, the project status, the system components and the suppliers of the components. The table also identifies the applications for which these BES systems are being used. Detailed cost data for each of these systems were obtained and presented in detail in appendix B. This section analyzes the battery and PCS cost components of these BES systems.

##### ***4.1.1 Batteries and Accessories***

The battery subsystem consists of individual battery modules connected in series to make up a battery string. Several battery strings, in turn may be connected in parallel to meet the power and energy requirement of the battery subsystem. The energy storage capability of the battery module, the basic building block, is fixed. Therefore, the cost of a battery subsystem is primarily driven by its energy rating, and to a lesser, but significant, extent by its power ratings.

The capability of a battery to deliver its stored energy is dependent on the rate of discharge. High rates of discharge reduce the energy delivery potential of the battery. Because of these operating characteristics, there can be multiple power and energy ratings for a battery subsystem. The application specification of each location will determine the way the battery is discharged; however, the battery may at any given location serve more than one application. The power rating of a BES system to a large extent is restricted by the power rating of the power conversion subsystem.

Because of the above mentioned reasons, it is difficult to compare the cost of batteries on a \$/kW or \$/kWh basis across applications, though the battery costs are driven by a combination of its power and energy ratings. Power quality systems for example, which typically require rapid discharge, are best compared on the basis of duration of protection (specified in seconds) provided and the extent of load (specified in kW/MW) it can protect. The high discharge rates of power quality applications makes the energy efficiency of the battery low.

**Table 4.1a: Cost of Projects and Products—Energy Storage Systems**

PROJECT/ PRODUCT	DESCRIPTION OF SYSTEM	COST OF STORAGE SUBSYSTEMS - constant 1995\$			TOTAL COST - constant 1995\$		
		STORAGE	PCS	BOP	\$/kW	\$/kWh	(000s of \$)
PREPA <sup>1</sup>	20-MW/14-MWh BES	22% (\$341/kWh)	27% (\$294/kW)	51%	1,102	1,574	22,042
CHINO <sup>2</sup>	10-MW/40-MWh BES	44% (\$201/kWh)	14% (\$258/kW)	42%	1,823	456	18,234
HAWAII ELECTRIC - HELCO <sup>3</sup>	10-MW/15-MWh BES	34.5% (\$304/kWh)	18.5% (\$212/kW)	47%	1,166	777	11,660
VERNON <sup>4</sup>	3-MW/4.5-MWh BES	32% (\$305/kWh)	19% (\$275/kW)	49%	1,416	944	4,250
METLAKATLA <sup>5</sup>	1-MW/1.2-MWh BES	-	-	-	-	-	1,200
CRESCENT <sup>6</sup>	500-kW/500-kWh BES	41% (\$518/kWh)	40% (\$506/kW)	19%	1,272	1,272	636
SDG&E <sup>7</sup>	200-kW/400-kWh BES	16% (\$658/kWh)	23% (\$1,855/kW)	61%	8,150	4,075	1,630
PM250 <sup>8</sup>	250-kW/167-kWh BES	20% (\$449/kWh)	50% (\$750/kW)	30%	1,500	2,245	375
ANCHORAGE MUNICIPAL L&P <sup>9</sup>	30-MVA/375-kWh SMES	45%	45%	10%	1,467	117,333	44,000

1. The PREPA plant is comparable to Chino, but built 6 years later. The PCS at PREPA was an improved version of the one installed at Chino - both supplied by GE. Balance of plant included \$0.6M for load interface, \$1M for finance charges, \$4.7M for building the facility and \$1.8M for services.
2. The balance of Plant includes \$0.15M for load interface, \$3.8M for facility and \$1.7M for services.
3. Though this plant was never built, the costs given were those of the winning bid submitted by GNB/GE. Energy rating specified @ a 3-hour discharge.
4. Detailed cost are provided in Appendix C.
5. Individual cost of each subsystem was not obtainable.
6. Installed at the Crescent Electric site in 1987/88. The balance of plant is exclusively the cost of the \$81,000 building Crescent Electric built to house the BES - the only cost Crescent Electric incurred.
7. The San Diego trolley project was a demonstration project and was over engineered in many respects.
8. The PM250 is a modular power management system product line developed by AC Battery Corporation. Up to 50% cost reduction is anticipated at a 40-MW/annum production volume.
9. Construction of this demonstration project is about to commence. Balance of plant includes the cost of constructing the building that will house the system.

**Table 4.1b: Cost of Projects and Products—Power Quality Systems**

POWER QUALITY PRODUCTS	DESCRIPTION OF SYSTEM	COST OF STORAGE SUBSYSTEMS - constant 1995\$			TOTAL COST - constant 1995\$		
		STORAGE	PCS	BOP	\$/kW	\$/MJ	(000s of \$)
PQ2000 <sup>10</sup>	2-MW/10-second Power Quality BES	9%	65% (\$316/kW)	26%	495	49,450	989
SSD <sup>11</sup>	8-MJ Power Quality SMES	30%	30%	40%	300 - 600 <sup>A</sup>	300,000	2,400
IPQ-750 <sup>12</sup>	750-kVA/6-MJ SMES	-	-	-	1,300	170,000	1,000
20C1000 <sup>13</sup>	1-kW/7.2-MJ FES	-	-	-	2,000	278	2 <sup>B</sup>
WFC <sup>14</sup>	1.5-kW/0.36-MJ FES	-	-	-	6,666	27,778	10 <sup>C</sup>
	20-kW/10.8-MJ FES	-	-	-	2,650	4,907	53 <sup>C</sup>

10. The PQ2000 was built by AC Battery Corporation. A high discharge rate distorts battery costs when specified in \$/kWh. The PCS cost includes the converter and the static switch. Balance of plant includes cost of delivery, installation and startup. The energy stored in the 2-MW system for 10 seconds is equivalent to 20 MJ - for purposes of comparison with SMES power quality systems.
11. The SSD units were developed by Superconductivity Inc. Since the duration of operation is limited by the energy stored in the superconducting magnet, an 8-MJ system can have multiple ratings.
12. Intermagnetics General Corporation product, cost projections. Estimated annual operating cost \$55,000. Like most other SMES products, this unit has a range of operating characteristics. Compared to the SI system, the IPQ-750 has a smaller converter.
13. A product developed by SatCon Technology Corporation. The 1-kW/2-kWh flywheel rotor is being developed by SatCon for telecommunication applications.
14. The World Flywheel Consortium product line.

A. Assuming an 8-MW rating for 1-second of protection and a 4-MW rating for 2-second of protection.

B. Targeted cost for production volumes in the lower thousands, additional cost of \$500-1,000 expected to be incurred for installation.

C. The price for a single product. Lower costs are anticipated for volume purchase.



Tables 4.2 and 4.3 list the costs of the battery subsystems of seven BES projects. They are similar because all of them have large energy storage capabilities, unlike the BES power quality systems. However, their energy ratings are dependent on the discharge rate. For example, the HELCO design was rated at a 3-hour rate. The Vernon plant was rated at a 1-hour rate, but retained ~50 percent state of charge at the end of the cycle. This disparity in the rate of discharge between the plants will introduce some distortion in the comparison of battery cost between projects on a kWh basis. The costs are listed in Table in 4.2 in nominal dollars, but are listed in 1995 dollars in Table 4.3.

**Table 4.2: Cost of Batteries and Accessories**

Name/Size of Plant	Nominal Cost (\$ 000s)	Power Rating (MW)	Energy Rating (MWh)	Year of Installation
PREPA (Flooded)	4641	20	14	1994
CHINO (Flooded)	5967	10	40	1987/88
HELCO (VRLA)	4,300	10	15	1993
VERNON (VRLA)	1,375	3	4.5	1995
CRESCENT ELECTRIC (Flooded)	168	0.5	0.5	1983/84
SDG&E (VRLA)	224	0.2	0.4	1991/92
BEWAG (Flooded)	4,300	8.5	8.5	1986

**Table 4.3: Normalized Cost of Batteries and Accessories - 1995\$**

Name/Type of Plant	Cost in 1995\$ (\$ 000s)	Cost in 1995\$ (\$/kW)	Cost in 1995\$ (\$/kWh)
PREPA (Flooded)	4,780	239	341
CHINO (Flooded)	8,052	805	201
HELCO (VRLA)	4,560	456	304
VERNON (VRLA)	1,375	458	305
CRESCENT ELECTRIC (Flooded)	259	518	518
SDG&E (VRLA)	263	1,315	658
BEWAG (Flooded)	6,015	707	707

The cost of each project listed in Table 4.3 in terms of \$/kW and \$/kWh must be examined together. Batteries with low power rating and high energy ratings will exhibit a very high \$/kW cost and lower \$/kWh cost. On the other hand, batteries in projects with large power needs for short durations will exhibit a low \$/kW cost and high \$/kWh cost.

Examining the per unit cost of batteries (in 1995\$) in Table 4.3, the costs of the SDG&E and BEWAG projects stand out. The VRLA batteries for SDG&E were supplied by Exide for peak shaving applications. They operated at 200 kW for 2 hours, to supply 400 kWh of energy; however, their rated 'nameplate' capacity was 827 kWh at a 6-hour rate. Such large variations in energy delivery capability for different discharge rates are typical for batteries.

The BEWAG battery is a Hagen flooded lead-acid battery. The system operates either at 8.5 MW for an hour or at 17 MW for 20 minutes (the battery has a 14.2-MWh energy rating at a 5-hour discharge rate). The \$707/kW and \$707/kWh cost based on its 1-hour rating is higher than

a comparable plant will now cost. The cost works out to \$350/kW and \$1,280/kWh based on its 20-minute rating. BEWAG was designed to provide spinning reserve and load-frequency control for the West Berlin 'island system' and is similar in operation to the PREPA project.

The 500-kW/500-kWh Crescent Electric battery, with an energy rating of ~ 1.4 MWh at a 5-hour rate, is a GNB flooded lead-acid battery. Its cost of \$518/kWh and \$518/kW is well above what is commercially available today.

The PREPA, Chino, Vernon and HELCO battery costs reflect today's cost. The PREPA battery, the only among the four rated for < 1 hour of operation, has a higher \$/kW cost. Except for Chino, which has the biggest battery, the batteries have costs in the range of \$300/kWh. The Chino battery is three times larger than PREPA and 9 times larger than Vernon, and appears to have benefited from economies of scale with a cost of \$201/kWh. It should also be pointed out that PREPA and Chino are flooded lead-acid battery technologies, while Vernon and HELCO are VRLA technologies.

The battery cost for single digit MW/MWh-scale systems for durations of ~1 hour is ~\$300/kW (or \$300/kWh). Since these are installed costs, larger batteries will have lower per unit cost. Manufacturing economies of scale are not anticipated. It should also be kept in mind that project prices are generally negotiated.

The costs associated with batteries for the smaller 250-kW/167-kWh PM250 unit developed by AC Battery Corporation is ~\$450/kWh, well above the ~\$300/kWh cost of the larger batteries. PM250 is the modular building block used to build larger BES systems. The PM250 unit at present costs ~\$375,000, however, costs are estimated to decline by 50 percent at production volumes of 40 MW/annum, i.e., 160 units/annum.

#### ***4.1.2 Power Conversion Systems***

The rating of a power converter is limited by its ability to dissipate heat generated by the current it handles. It is rated in MVA. Assuming the power factor remains close to 1, the MVA and MW ratings are essentially the same. In general, the rating refers to the ability of the system to continuously handle the rated power. However, these systems have the ability to handle higher power (larger currents) for brief periods of time (in seconds). The Insulated Gate Bipolar Transistor (IGBT) and Gate Turn-off Thyristors (GTO) are the two main technologies used in power conversion systems.

The PCS costs of the seven plants are tabulated below:

**Table 4.4: Power Conversion System Costs of BES**

Name/Type of Plant	Nominal Cost (\$ 000s)	Cost - 1995\$ (\$ 000s)	Cost - 1995\$ (\$/kW)
PREPA - 2x10-MVA converter	5,713	5,884	294
CHINO - 10-MVA converter	1,911	2,579	258
HELCO - 10-MVA converter	2,000	2,123	212
VERNON - 3x1-MVA converter	825	825	275
CRESCENT ELECTRIC - 500-kVA converter	164	253	506
SDG&E - 200-kVA converter	316	371	1,855
BEWAG - 2x8.5-MVA converter	4,300	6,015	353

The cost of the 200-kW transistor-based PCS at SDG&E was very high, mainly because of over-engineering the system. It was a self-commutated, IGBT-based voltage sourced PCS capable of 4-quadrant operation. The PCSs at Chino and PREPA, both supplied by GE, use self-commutated GTO thyristor technology and are capable of 4-quadrant operation. The two 10-MW PCS supplied to PREPA were considered an improved version of the 10-MW PCS supplied to Chino. The higher cost of the PREPA unit does not seem to suggest a learning-curve cost reduction pattern. However, cost does seem to have decreased from that seen in the Crescent Electric and BEWAG units. The BEWAG PCS is a 2x8.5-MW line-commutated thyristor-based unit.

PCS cost, primarily driven by its kW rating, seems to be in the region of \$300/kW today. The HELCO unit was bid at ~\$212/kW, while the three 1-MW PCS at Vernon has a per unit cost of \$275/kW. The PCS cost listed in Table 4.1a for the smaller 250-kW/167-kWh PM250 unit includes the cost of the converters, monitors and controls. It accounts for 50 percent of the unit cost, and is equivalent to ~\$750/kW. At production volumes of 160 units/annum the total cost of the system is expected to come down by as much as 50 percent.

The power converters in large energy BES systems and power converters in power quality systems are typically rated differently. Converters in power quality systems operate for durations in seconds, where as the large BES systems require a continuous rating.

Power electronics for BES power quality systems account for the largest portion of the cost, since the batteries in these systems are small (energy in tens of kWh). The PCS (power converter, controls, monitors and static switch) account for ~65 percent of the \$989,000 PQ2000 system cost. This amounts to ~\$300/kW for the 2-MW/10-second unit. The power converter itself will cost approximately half of the \$300/kW price, with the static switch accounting for the balance of the cost.

#### **4.1.3 Balance of Plant - System Integration and Facility Development**

Balance of plant as discussed earlier encompasses the facility to house the equipment and interface between the ES systems and the customer/utility. In addition to buildings and interface equipment, the provision of such services as data gathering/trending, project management, transportation, permits, training, spares, finance charges, etc., account for approximately 50% of the BES project costs, as illustrated in Table 4.1.

Expenditures associated with systems studies, design, project management and other related services account for up to 10 percent of the total cost. Finance charges (average funds used during construction) typically account for 5 percent of the system cost, while taxes account for approximately 5 percent. Taxes accounted for 8.25 percent of the Vernon plant cost. Transportation and packaging accounted for approximately 5 percent.

Facility development cost is site specific. Among the plants investigated, it accounts for about 20 percent of the total project cost. Expenditures associated with site development, packaging, and transportation could be greatly reduced by transportable (housed in containers that can be mounted on trailers with ease) modular designs. Although such standardized modular design by integrators may not achieve an optimum match between the battery system and the utility requirements, the resulting cost savings may more than off-set the shortcomings resulting from the lack of optimal design.

The trend towards having turn-key projects has the potential to drive costs down, since these in most instances are negotiated prices. In the case of Chino and PREPA, architectural and engineering firms were involved, and the projects were broken out to the lowest bidder of major components. Turn-key projects tend to have better coordination between different hardware suppliers, and tend to minimize integration and administrative costs. PREPA has plans for a second BES facility that is expected to be built on a turn-key basis.

The balance of plant component costs for the PQ2000 and PM250 units are 26% and 30% respectively, as they are product costs, and not the total installed project cost seen by the end-use customer. Interconnections to customer facility, customer site preparation and other items are additional costs that may have to be borne by the customer.

#### *4.2 Analysis of SMES Costs*

A commercial 8-MJ (2.2-kWh) unit (SSD system), developed by Superconductivity, Inc., suited for industrial power quality applications, is estimated to cost ~\$2.4 million. It has the ability to protect customers from momentary outages, voltage dips/surges, and its ability to correct harmonic distortions and power factors. The storage, PCS and balance of plant cost of this system account for approximately 30%, 30% and 40% of the total project cost, respectively. Intermagnetics General Corp's IPQ750 is a 6-MJ/750-kVA system and is priced at ~\$1.0 million. Though the magnet size of both the SSD and IPQ750 system are comparable, the converter of the SSD system has a larger power rating.

In small magnets, the interaction of the circulating currents with the magnetic field produces forces that can be carried by the conductor itself. However, large magnets will require a structure to support the forces between the conductors. For these reasons, the capital cost associated with the energy component of SMES is highly dependent on its size. In addition, the refrigeration and air conditioning systems required to maintain the conductor in a superconducting state makes building of small superconducting magnet-based systems (with power ratings of < ~1 MW) less economical.



The cost of the storage component for the 8-MJ micro-SMES is ~\$700,000, which is equivalent to \$90,000/MJ. However, the magnet for the 1,350-MJ SMES (375 kWh) in Anchorage is expected to cost ~\$20 million, equivalent to \$15,000/MJ (\$54,000/kWh). One should bear in mind that the micro-SMES is a commercial product with a cost structure that is reasonably well defined, while the Anchorage SMES is going to be a one-of-a-kind demonstration project.

The 30-MVA Anchorage system is capable of supplying energy for 45 seconds (30 MVA\*45 seconds = 1,350 MJ) and is expected to cost \$44 million. Of the \$44 million, the magnet and PCS are estimated to cost \$20 million each, while the balance will be spent on facility development. The magnet will be built on-site.

As discussed earlier, the PCS for both of these technologies is very similar to that of battery-based power quality systems. The SSD<sup>®</sup> PCS cost is estimated at ~\$300/kW.

#### *4.3 Analysis of FES Costs*

Preliminary cost estimates of FES (excluding the PCS) exist. For a 1,000-kWh/100-kW flywheel system optimized for energy at a production volume of 2000 units, American Flywheel Systems Inc. has estimated the direct cost (excludes overheads) at \$200/kWh. This estimate includes the cost of the rotor, shaft/structure, motor/generator, bearing, cooling, vacuum assist, containment, and system assembly/installation. An energy component cost estimate of \$800/kWh and a power conversion system capital cost estimate of \$220/kW have also been made<sup>5</sup>. The dc voltage output of the motor/generator set in the FES has to be conditioned by a typical power conversion system to interface with the external ac supply/load.

World Flywheel Consortium has priced its small 0.10-kWh/1.50-kWh system at ~\$10,000. The slightly larger 1.5-kWh/50-kW units are priced at \$34,000. SatCon Technology Corporation has developed a flywheel rotor capable of storing 2 kWh (7.2 MJ) of energy. SatCon is anticipating to market a 1-kW/2-kWh system for \$2,000 (at a production volume in lower thousands) for the cable and telecommunication industry. It anticipates an additional cost of \$500 to \$1,000 for installation.

For the FES system a separate building will not be necessary, as the containment vessel for the flywheel in most instances will be placed underground. This feature may provide the potential to reduce costs associated with the balance of plant for the larger FES systems, assuming underground containment will be less expensive.

The above costs were obtained for advanced high-speed, low-loss FES systems. A conventional low-speed FES installed at the Usibelli coal mine was also investigated. It has the capability to store 225 MJ (62.5 kWh) of energy. The system consists of the 225-MJ flywheel, a motor/generator set with a continuous rating of 1.8 MW and a 3-second rating of 5.2 MW. The entire system was installed in 1983 at a cost of \$3.5 million (\$15,555/MJ or \$56,155/kWh of energy stored in the flywheel).

---

<sup>5</sup> "The Emerging Roles of Energy Storage in a Competitive Market," Proceedings of a DOE Workshop, Pleasanton, CA. December 6-7, 1994.

#### 4.4 Cost Reduction Potential of Energy Storage Systems

A summary of component and system cost reduction potential is given in Table 4.5. Figure 4.1, provided in the EPRI Technical Assessment Guide illustrates the manner in which estimated and actual capital cost varies for new technologies. For example, some FES developers, in their very early stages of development, estimate the price of the energy storage subsystem to be approximately double the estimated direct cost of \$200/kWh. The direct cost estimate of \$200/kWh is based on a 1,000-kWh/100-kW system optimized for energy at a production volume of 2,000 units. However, other developers of FES have estimated the same energy component of the FES system to cost \$800/kWh (assumptions of production volume not known). This wide range of cost estimates are typical for a technology in its early stages of development.

Fig: 4.1: Capital Cost Learning Curve

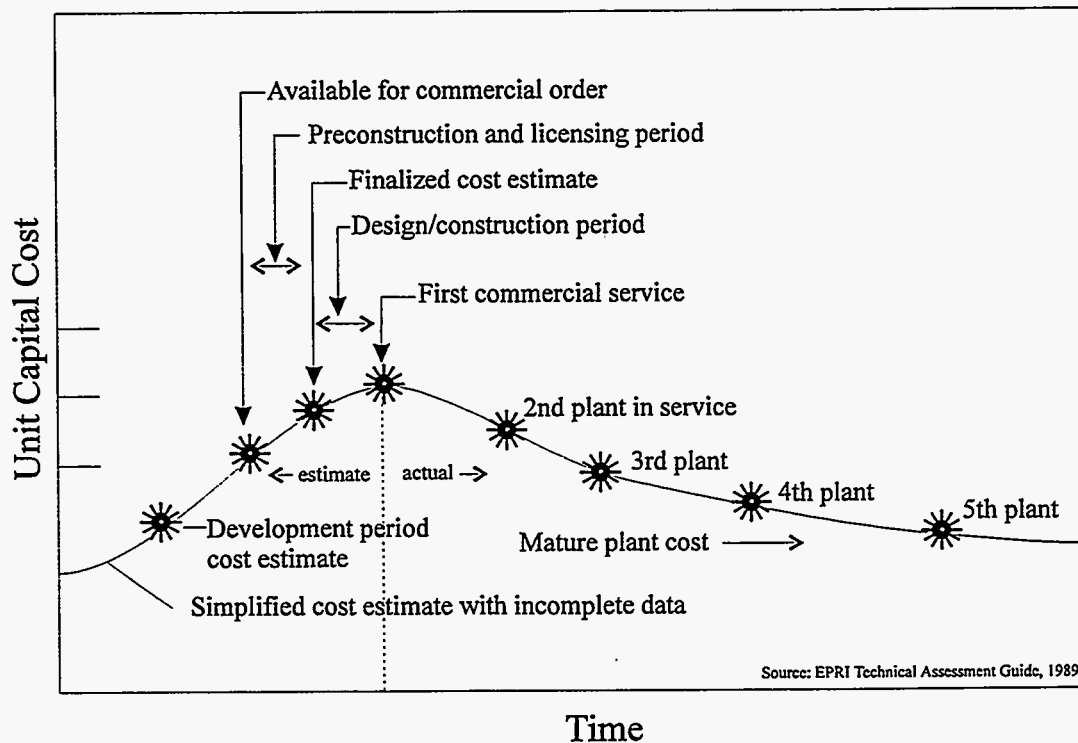

The design/production of high-speed, low-loss (spinning at a levitated state) flywheel energy storage subsystems are in development/available for commercial order stages in the capital cost learning curve. The storage subsystem of the micro-SMES (low-temperature, superconducting magnet in the 1- 8-MJ sizes) on the other hand have several commercial systems in the market. The battery costs for the BES subsystem, with production volume in \$100s of millions of dollars, can be assumed to have plateaued. However, BES systems for storage and power quality applications are in the commercialization phase.

The cost of power conversion and control subsystems for ES systems is on a downward trend, but substantial cost reductions (of GTO thyristor-based PCS) are not anticipated by system developers. PCS developers predict that volume production provides the greatest potential for any cost reduction, but large markets to facilitate large production volumes are yet to emerge. IGBT-based converters are low-power devices (capable of handling lower voltage and current);

however, many such converters can be connected in parallel to achieve the required power rating.

With IGBTs setting the trend in the power electronics industry, some PCS manufacturers are advancing the concept of modular PCS to bring the cost of PCS down. Modular PCS with lower power rating may be easier and cheaper to produce and may have wide-scale applications (outside the energy storage market) and can be networked using software to achieve the same power rating of a single large converter. Production of large numbers of modular PCS units will benefit from the economies of mass production.

Each of the three storage technologies investigated are at different stages of development. The large MW/MWh-scale BES systems are now commercially available, but are designed on a one-of-a-kind basis. Though most of the building blocks that make up the system are off-the-shelf products, the system integration, construction of a building to house them, and transportation account for ~50 percent of the total project cost.

The total project cost of a BES system ranges between \$1,200-1,500/kW for a two-hour system (as seen in Table 4.1a), depending on the site and application requirements. A cost reduction of up to 20 percent is projected by vendors, which consists of a 20 percent reduction in the cost of batteries, a 5-10 percent reduction in the PCS cost and a 10-15 percent reduction in the balance of plant costs. The cost of flooded lead-acid batteries at present is ~\$300/kW for a 1-hour battery. Large MW/MWh-scale SMES and FES systems are yet to be built.

The PCS costs obtained for the projects includes the converter/controls themselves, but also includes many variable components such as the AC and DC switchgear, filters etc. At times the costs of monitoring and control equipment and software were not listed as separate cost items. They were presumably hidden in other cost items, probably under PCS cost. PCS costs of the larger energy units with continuous power ratings were found to be ~\$300/kW. BES system developers expect this cost to drop 10-20 percent.

Smaller BES systems for power quality applications are available for between \$400-\$500/kW (PQ2000 system). Since power quality problems experienced industry-wide on the utility side of the meter are very similar, greater potential exists for a uniform product being developed, with the potential for volume production cost savings being achieved. Batteries account for ~10 percent of the cost of these systems, while electronics that include the PCS, and transfer switch account for close to 65 percent of the cost. Projected cost savings for the PQ2000 system are a 25-35 percent reduction in the cost of electronics, 5-10 percent reduction in battery and accessories cost, and 10-15 percent reduction in assembly and factory set-up cost.

Micro-SMES systems with very small energy storage ratings are now commercially available for power quality applications. An 8-MJ (2.22-kWh) system at present is commercially available at a cost of \$2.4 million from Superconductivity Inc. However, a cost reduction of ~25 percent is projected. The superconducting magnetic storage unit, which at present accounts for ~30 percent of the cost of this product, is expected to decrease in cost by as much as 30-50 percent over the next 3-5 years.

The PCS, which is similar to that of a corresponding battery-based power quality system, accounts for ~30 percent of the system cost and its cost is expected to drop by 25 percent.

FES power quality systems in the 0.1- 1.5-kWh sizes with power ratings from 1.5 kW to 50 kW are being developed by World Flywheel Consortium. Though no commercial systems are presently in operation, a 0.10-kWh (0.36-MJ)/1.5-kW system has an estimated sample cost of \$10,000 while a 1.5-kWh (5.4-MJ)/50-kW system has a sample cost of \$34,000. The cost break-down of these power quality systems were not available. There was no basis for reliable cost projection of a larger energy storage FES system, because of its early stages of development.



**Table 4.5: Industry View of Present and Projected Cost of Energy Storage System**

ENERGY STORAGE SYSTEM	PRESENT COST	PROJECTED COST REDUCTION	INDUSTRY INPUTS	REMARKS
<b>SUBSYSTEMS</b>				
Flooded Lead-Acid Batteries	\$300/kWh	5-10%	GNB, AC Battery, demos	Unit cost of batteries and accessories, specified in \$/kWh are highly dependent on the rate of discharge. Cost specified is @ a 1- 2-hour rate.
VRLA	\$300/kWh	5-10%	GNB, demos	Unit cost of batteries and accessories, specified in \$/kWh are highly dependent on the rate of discharge. Cost specified is @ a 1- 2-hour rate.
Superconducting Magnet	\$54,000/MJ	-	SI, B&W, IGC	Based on the planned 1,350-MJ (375-kWh) superconducting magnet for the Anchorage project, projected cost is \$20M. Large economies of scale seem to exist for larger superconducting magnets.
Flywheels	\$200/kWh*	-	AFS, WFC, SatCon, literature	* \$200/kWh is a direct cost estimate, based on a 1,000-kWh/100-kW system optimized for energy at a production volume of 2000 units (includes rotor, shaft/structure, motor/generator, bearing, cooling, vacuum assist, containment, system assembly/ installation). Energy component cost estimate of \$800/kWh has also been made.
AC/DC Power Conversion Systems	\$200-300/kW	25-40%	AC Battery, SI, demo	SI anticipates up to a 40% drop in its PCS costs, which at present cost ~300/kW based on power quality applications, with operating durations in seconds.
Static Transfer Switch	~\$125/kW	25%	AC Battery	
Interface of ES system with External Supply	-	-	Demo	Very Site specific
Facility	\$100 - 300/kWh	-	Demo	Site specific, partly dependent on size and type of energy storage medium.
<b>TOTAL SYSTEM</b>				
BES - large storage applications	\$1,200 - 1,500/kW for a 1- 2-hr system	10-20%	Demonstration projects, GNB	The energy rating of large BES system is highly dependent on the application/discharge rate of the plant.
BES - power quality	~ \$450/kW	20%	AC Battery	Projections for PQ200. 2-MW/10-second power quality system.
SMES - utility scale	\$1,500/kW	N/A	B&W	The 30-MVA, 40-second unit for Anchorage is estimated to cost \$44M. The utility is contributing \$12.5M towards this demonstration project.
SMES - power quality	\$300-600/kW	30-40%	SI, IGC	An 8-MJ system costs \$2.4 M. Could be used as an 8-MVA system for 1-second dip protection or with a 2- 3-MVA rating for 3 seconds.
FES - power quality	~\$2,000/kW for a 2-hr system	-	SatCon, WFC	Is a 2-kWh (7.2-MJ) flywheel rotor developed by SatCon. With a production volume in lower thousands, it is anticipated to cost \$2,000 + installation, for a 1-kW/2-hr system.

## 5.0 CONCLUSIONS

There are several applications in the electric utility industry in which the three storage systems considered in this study can be used. Currently, BES and SMES systems are being used for niche applications. Significant cost reductions are required if these technologies are to gain widespread use in the electric utility sector.

Though prototypes of small power quality FES systems have been produced, they have not yet been demonstrated at any commercial facilities. FES systems exhibit attractive volumetric energy density, and potentially long life. Furthermore, since FES could be placed underground, it potentially has a very low foot print. These features warrant an early demonstration of the technology so that firm cost/benefits can be estimated.

Current costs of \$1,200-1,500/kW are common for BES systems with 1-2 hours of storage capacity. The batteries and the PCS, however, contribute only about 50 percent of the cost. Since both the lead-acid battery and the PCS are mature technologies, a cost-reduction of only 10-15 percent of these components is expected over time. The bulk of the cost reduction must come from the remaining 50 percent, which is comprised of three components:

- Facilities to house the equipment - 20 percent
- System design and integration - 10 percent
- Transportation, finance charges and taxes - 15 percent

The focus of system suppliers is to develop a factory-assembled, modular, transportable BES system to reduce the costs associated with facilities and engineering services. AC Battery Corporation has been a leader in promoting the concept successfully. Other vendors are also seriously considering standardized modular designs.

The present cost structure of the three storage technologies makes them uncompetitive for applications that require both high power (MW scale) and long durations (>1 hour). It is becoming increasingly clear that storage technologies cannot be viewed as a generation technology. With fast acting power conversion and control systems, and the rapid response capability of the storage system, it appears that ES systems are best suited for dynamic system operation.

This is especially true for SMES, as energy available in superconducting magnets, unlike batteries, is independent of its discharge rating which makes them attractive for high-power and short-energy burst applications. The preliminary estimates of the storage component cost of the Anchorage SMES project is \$54,000/kWh. This is the first large superconducting magnet being built for utility applications. Significant cost reductions will be required if SMES is to be viable for utility applications on a wide scale, and potential for such cost reduction exists for this advanced technology system.

BES and SMES are more competitive for power quality applications for two primary reasons. First, the power quality problems experienced by industry are very similar in nature, hence a uniform product line can be developed and marketed, achieving economies of scale.

Second, because of the large economic losses caused by power supply perturbations, industries are willing to invest substantial amounts in equipment to shield them from these perturbations. The increasing sensitivity of customer machinery to these disturbances presents a growing market for protection systems. Cost projections indicate a 10-20 percent cost reduction for BES, and 30-40 percent reduction for SMES systems in this application. Cost reductions through technology improvement and volume manufacture are essential for the competitiveness of all the technologies and system components.

The PCS presently cost ~\$300/kW in the large energy storage project market and is not projected by industry to drop by more than 10 percent. On the other hand, the power quality application market expects the price to drop by 25-40 percent. The concept of modular PCS is now being promulgated as a way to drive PCS cost down. Modular PCS is composed of many small converters that are networked in parallel (using software) to achieve the same power rating of a single large converter, but benefit through the economies of mass production. The individual units, if designed to operate with a sufficient degree of autonomy, can be rescaled dynamically. This offers the advantage of redundancy and on-line maintenance. High efficiency can be maintained at low power throughputs, because only the minimum required number of power converters need to be energized. Hence modular PCSs are expected to provide solutions at a lower cost with better redundancy, reliability, and efficiency.

## REFERENCES

1. Battery Energy Storage for Utility Applications: Phase 1 - Opportunities Analysis, Sandia National Laboratories Report-SAND94-2605, October 1994.
2. Specific System Studies for Battery Energy Storage for Electric Utilities, Sandia National Laboratories Report-SAND93-1754, August 1993.
3. The Market Potential for SMES in Electric Utility Applications, An Arthur D. Little Inc. report prepared for Oak Ridge National Laboratory, ORNL/Sub/85-SL889/1.
4. Chino Battery Energy Storage Power Plant, Engineer-of-Record Report, EPRI TR-101787, December 1992.
5. Updated Cost Estimate and Benefit Analysis of Customer-Owned Battery Energy Storage, EPRI EM-3872, January 1985.
6. EPRI Technical Assessment Guide - 1989.
7. DeWinkel Carel, 'Storing Power for Critical Loads', IEEE Spectrum, June 1993.
8. California Energy Commission, Energy Technology Status Report, (Draft Report 1996).
9. Personal Communication, T. Nelson, San Diego Gas & Electric, May 1995.
10. Personal Communication, Wenceslao Torres, Puerto Rico Electric Power Authority, June 1995.
11. Personal Communication, Mr. George Hunt, Director, Battery Energy Storage Systems, GNB Technologies.
12. Personal Communication, Mr. Robert Flemming, Managing Director, AC Battery Corporation.
13. Personal Communication, Mr. Michael Gravely, Executive Vice President. Superconductivity, Inc.
14. Personal Communication, Mr. Glenn Campbell, Babcock & Wilcox.
15. Personal Communication, Dr. Edward Zorzi, Vice President - Engineering & Technology, American Flywheel Systems, Inc.
16. Personal Communication, Mr. Keith Finger, Intermagnetics General Corporation.
17. Personal Communication, Craig Driscoll, SatCon Technology Corporation.
18. Load Stabilizer Systems Instructions, Usibelli Coal Mine, General Electric-Req'n: 541-42110.

### Appendix A: Persons Contacted to Obtain Cost Information

Project/Product	Source of Information
The 20-MW/14-MWh BES project at the Sabana Llana Substation in Puerto Rico	Mr. Wenceslao Torres Assistant Head, P & R Division
The 10-MW/40-MWh BES project at the Chino Substation in Southern California	Mr. Steve Eckroad, Manager, Battery and SMES Technologies - EPRI
The 10-MW/15-MWh BES project for Hawaii Electric Light Company	Mr. George Hunt Director, Battery Energy Storage Systems GNB Technologies
The 3-MW/4.5-MWh BES plant at the GNB Lead Reclaiming Factory	Mr. George Hunt Director, Battery Storage Systems GNB Technologies
The 1-MW/1.2-MWh BES unit for Metlakatla Power & Light	Mr. George Hunt Director, Battery Storage Systems GNB Technologies
The 500-kW/500-kWh BES for the Crescent Electric Cooperative	Mr. R.B. Sloan; Mr. Steve Eckroad Crescent Electric; Electric Power Research Inst.
The 200-kW/400-kWh BES for San Diego Trolley's Grossmont Substation	Mr. Tiff Nelson San Diego Gas & Electric
PM250, the 250-kW/167-kWh BES developed for a power management application by AC Battery Corporation	Mr. Robert Flemming Chief Operating Officer AC Battery Corporation
PQ 2000, the 2-MW/10-second power quality system developed by AC Battery Corporation	Mr. Robert Flemming Chief Operating Officer, AC Battery Corporation
The SSD <sup>®</sup> 2- 8-MJ SMES unit developed by Superconductivity, Inc.	Mr. Michael Gravely Executive Vice President, Superconductivity, Inc.
The 30-MVA/1,350-MJ SMES project for Anchorage Municipal L & P	Mr. Glenn Campbell Babcock & Wilcox
PQ750, 750-kVA/6-MJ Micro-SMES developed by Intermagnetics General Corporation	Keith Finger SMES Product Manager; Intermagnetics General
20C1000, 1-kW/2-kWh FES developed by SatCon Technology Corporation	Craig Driscoll SatCon Technology Corporation
WFC Flywheel product line for power quality applications	James Folk President, World Flywheel Consortium
The AFS2000-10 FES systems for automotive applications, and utility scale FES design and development	Dr. Edward Zorzi Vice President - Engineering & Technology American Flywheel Systems, Inc.

## Appendix B: Components of Cost for an Energy Storage System

(Modification of table 8.2 of the Opportunities Analysis Report to include all three technologies.)

A. AC SOURCE/LOAD INTERFACE TO STORAGE SYSTEM	<ol style="list-style-type: none"> <li>1. New lines to serve installation (e.g., 4,12, 69 kV)</li> <li>2. Transformer between utility voltage and storage system AC voltage</li> <li>3. Protection Devices</li> </ol>
B. POWER CONVERSION SYSTEM	<ol style="list-style-type: none"> <li>1. AC Switchgear/Disconnect</li> <li>2. Rectifier/Inverter</li> <li>3. DC Swtichgear/Disconnect</li> <li>4. Protection Devices (e.g., switches, breakers, fuses)</li> </ol>
C. STORAGE SUBSYSTEM & ACCESSORIES	<ol style="list-style-type: none"> <li>1. BES system: Batteries, interconnects, protection devices, racking, etc.</li> <li>2. SMES system: Magnets, leads, enclosure, thermal shields, cryogenics, pumps, etc.</li> <li>3. FES system: Flywheel, bearings, center post, containment, motor/generator set, etc.</li> </ol>
D. MONITORS & CONTROLS*	<ol style="list-style-type: none"> <li>1. Energy storage subsystem management, monitoring and control</li> <li>2. Power Conversion system monitoring and control</li> <li>3. Facilities monitoring and control</li> </ol>
E. FACILITIES*	<ol style="list-style-type: none"> <li>1. Foundation and Structure (and associated labor)</li> <li>2. Materials</li> <li>3. Lighting/Plumbing</li> <li>4. Finish Grade/Landscape</li> <li>5. Access Road</li> <li>6. Grounding/Cabling</li> <li>7. HVAC</li> </ol>
F. FINANCING	
G. TRANSPORTATION*	
H. TAXES	
I. SERVICES	<ol style="list-style-type: none"> <li>1. Project Management</li> <li>2. Installation</li> <li>3. Studies (e.g., relays, harmonic filters)</li> <li>4. Data Gathering/Trending</li> <li>5. Permits</li> </ol>
J. OPERATION & MAINTENANCE	<ol style="list-style-type: none"> <li>1. Service Contract</li> <li>2. Training</li> <li>3. Inspectors</li> </ol>

\* For the turn-key systems evolving, separate costing of these items may not be necessary. However, these items will be part of the specification upon which turn-key vendors bid.

**Appendix C: Component Cost of BES Projects**

**Table 1: Components of Cost for a Battery Energy Storage System  
at CHINO, 10-MW/40-MWh Flooded Lead-Acid Battery (1987/88)**

		Cost (\$ 000's)	Percentage	\$/kW	\$/kWh
AC SOURCE/LOAD INTERFACE TO BATTERY SYSTEM		150	1.1%		
POWER CONVERSION SYSTEM		1,911	14.2%	191	-
• base price	1,486				
• differential current protection - ac	16				
• design review, field install: testing & startup	34				
• dc switchgear	207				
• MVAR Regulator	22				
• Spares for startup & service	66				
BATTERIES & ACCESSORIES		5,967	44.0%	597	149
MONITORS & CONTROL		-	-		
FACILITIES		3,780	27.9%		
FINANCING		-	-		
TRANSPORTATION		-	-		
TAXES		-	-		
SERVICES		1,705	12.8%		
• Proj: Mgmt, Engineering & Constr Mgmt - Client	505				
• Project Management - Contractor	375				
• Landscaping, testing etc.	150				
• Permit Fee & Improvements	675				
OPERATION & MAINTENANCE		-	-		
TOTAL ESTIMATED COST		13,513	100.0%		
UNIT COST		1351\$/kW			
		338\$/kWh			



**Appendix C: Component Cost of BES Projects**

<b>Table 2: Components of Cost for a Battery Energy Storage System at PREPA, 20-MW/14-MWh Flooded Lead-Acid Battery (1994)</b>					
		Cost (\$ 000's)	Percentage	\$/kW	\$/kWh
<b>AC SOURCE/LOAD INTERFACE TO BATTERY SYSTEM</b>		672	3.1%		
• Transformer	331				
• Protection (115-kV relays, etc.)	341				
<b>POWER CONVERSION SYSTEM</b>		5,713	26.7%	286	-
• AC Switchgear	182				
• Rectifier/Inverter	4,860				
• DC Switchgear	671				
<b>BATTERIES &amp; ACCESSORIES</b>		4,641	21.7%	232	332
• Cells, racks, watering, fluid pumps, etc.	4,591				
• Chargers, temporary storage	50				
<b>MONITORS &amp; CONTROL</b>		1,244	5.8%		
<b>FACILITIES</b>		4,748	22.2%		
• Structures, materials, HVAC	4,711				
• Landscape	24				
• Access Road	13				
<b>FINANCING</b>		1,000	4.7%		
<b>TRANSPORTATION</b>	included in price	-	-		
<b>TAXES</b>		891	4.2%		
<b>SERVICES</b>		1,877	8.8%		
• Project Management	385				
• Design, Specifications, Bid Evaluation	1,492				
<b>OPERATION &amp; MAINTENANCE</b>		614	2.9%		
<b>TOTAL ESTIMATED COST</b>		21,400	100.0%		
<b>UNIT COST</b>		1,070\$/kW			
		1,518\$/kWh			

**Appendix C: Component Cost of BES Projects**

<b>Table 3: Components of Cost for a Battery Energy Storage System at CRESCENT ELECTRIC, 500 kW/500 kWh</b>				
<b>(Hardware built in 1983, was tested in test facility and moved to Crescent Electric in 1987)</b>				
	<b>Cost (\$ 000's)</b>	<b>Percentage</b>	<b>\$/kW</b>	<b>\$/kWh</b>
<b>AC SOURCE/LOAD INTERFACE TO BATTERY SYSTEM</b>	-	-		
<b>POWER CONVERSION SYSTEM</b>	164	39.7%	328	-
• Converter - 143				
• Shipping - 1				
• Installation - 5.6				
• Taxes & Insur - 6.1				
• Contingency - 7.7				
<b>BATTERIES &amp; ACCESSORIES</b>	168	40.7%	336	336
• Cells - 125				
• Shipping - 6.6				
• Installation - 23				
• Taxes & Insur - 6.1				
• Contingency - 7.5				
<b>MONITORS &amp; CONTROL</b>	-	-		
<b>FACILITIES</b>	81	19.6%		
• Building				
<b>FINANCING</b>	-	-		
<b>TRANSPORTATION</b>	-	-		
<b>TAXES</b>	-	-		
<b>SERVICES</b>	-	-		
<b>OPERATION &amp; MAINTENANCE</b>	-	-		
<b>TOTAL ESTIMATED COST</b>	413	100.0%		
<b>UNIT COST</b>	826	\$/kW		
	826	\$/kWh		

Costs were obtained from the EPRI report on 'Updated Cost Estimate and Benefit Analysis of Customer owned Battery Energy Storage' (EPRI EM-3872). The cost estimates in this report were based on the BES now installed at Crescent Electric.

Facilities cost is the \$81,000 cost incurred by Crescent to construct the building to house the BES. Cost incurred for the integration, project management etc., were not available.

**Appendix C: Component Cost of BES Projects**

**Table 4: Components of Cost for a Battery Energy Storage System  
for the San Diego Trolley Battery Project, 200 kW/400 kWh (1991/92)**

	Cost (\$ 000's)	Percentage	\$/kW	\$/kWh
AC SOURCE/LOAD INTERFACE TO BATTERY SYSTEM	-	-		
POWER CONVERSION SYSTEM	316	22.8%	1,580	-
BATTERIES & ACCESSORIES	224	16.1%	1120	560
MONITORS & CONTROL	158	11.4%		
FACILITIES (Balance of Plant)	255	18.4%		
FINANCING	-	-		
TRANSPORTATION	-	-		
TAXES	-	-		
SERVICES	435	31.3%		
• ENGINEERING SERVICES - 300k				
• PROJECT MANAGEMENT - 135k				
OPERATION & MAINTENANCE	-	-		
TOTAL ESTIMATED COST	1,388	100.0%		
UNIT COST	6,940\$/kW			
	3,470\$/kWh			

**Appendix C: Component Cost of BES Projects**

**Table 5: Components of Cost for a Battery Energy Storage System  
at GNB in Vernon, California, 3 MW/4.5 MWh (1995)**

	Cost (\$ 000's)	Percentage	\$/kW	\$/kWh
AC SOURCE/LOAD INTERFACE TO BATTERY	-			
POWER CONVERSION & CONTROL SYSTEM	825	19.4%	275	-
BATTERIES & ACCESSORIES	1,375	32.3%	458	305
BALANCE OF PLANT	1,500	35.5%		
FINANCE	-			
TRANSPORTATION/PACKAGING	195	4.6%		
• TAXES: State, County & secondary county	350	8.2%		
TOTAL ESTIMATED COST	4,250	100.0%		
UNIT COST	1,416\$/kW			
	944\$/kWh			

**Appendix C: Component Cost of BES Products**

<b>Table 6: Components of Cost for a PM250 Unit-250-kW/167-kWh Battery-Based Energy Storage Unit</b>				
	Cost (\$ 000's)	Percentage	\$/kW	\$/kWh
POWER CONVERSION SYSTEM/ MONITORS & CONTROL	190	50%	760	-
BATTERIES & ACCESSORIES	75	20%	300	450
ASSEMBLY & TESTING	75	20%		
TRANSPORTATION Delivery & Setup	35	10%		
<b>TOTAL ESTIMATED COST</b>	<b>375</b>	<b>100%</b>		
<b>UNIT COST</b>	<b>1500\$/kW</b>			
	<b>2245\$/kWh</b>			

**Appendix C: Component Cost of BES Products**

<b>Table 7: Components of Cost for a PQ2000-2-MW/10-Second Battery-Based Power Quality Unit</b>		
	Cost * (\$ 000's)	Percentage
AC SOURCE/LOAD INTERFACE TO BATTERY SYSTEM	52	5.3%
POWER CONVERSION & CONTROL SYSTEM	630	64%
• Static Switch		
• PCS, CONTROLS/MONITORS		
BATTERIES & ACCESSORIES	90	9.1%
• Cells		
• Racks, watering, fluid pumps, etc.		
DELIVERY & SETUP	50	4.7%
TAXES	67	6.3%
SERVICES	100	9.5%
• Assembly & Setup in Factory		
<b>TOTAL ESTIMATED COST</b>	<b>989</b>	<b>100.0%</b>
<b>UNIT COST</b>	<b>495\$/kW</b>	

\*The percentage categories represent averages of the first and second systems built. Certain costs are unique to customer requirements, and include overheads related to documentation for project funding. This cost will not occur in normal commercial sale.

**Appendix D: DESCRIPTION OF SYSTEM COMPONENTS AND APPLICATIONS OF PROJECTS**

PROJECT	STORAGE TECHNOLOGY	VENDOR	POWER CONVERSION SYSTEM	VENDOR	PROJECT STATUS	APPLICATIONS
PREPA	Flooded Lead-Acid Battery	C&D	GTO Thyristors, 18 pulse, self commutated	GE	Operational	Spinning Reserve, Voltage Regulation, Generation Reserve
CHINO	Flooded Lead-Acid Battery	Exide	GTO Thyristor, 18 pulse, self commutated	GE	Operational	Test facility - operating modes included load leveling, voltage-frequency-VAR regulation and spinning reserve.
HAWAII ELECTRIC - HELCO	VRLA	GNB	GTO Thyristor, 18 pulse self commutated	GE	Never built	Frequency Regulation, Spinning Reserve
VERNON	VRLA	GNB	GTO Thyristor, 12 pulse, self commutated	GE	Operational	Power Quality, Back-up Power, Peak Shaving
METLAKATLA	VRLA	GNB	GTO Thyristor, 18 pulse, self commutated	GE	Being built	Voltage Stability, Spinning Reserve
CRESCENT	Flooded Lead-Acid Battery	GNB	Line commutated, 12 pulse, SCR	Firing Circuits	Operational	Customer Peak Shaving
SDG&E	VRLA	Exide	IGBT, 18 pulse self commutated	Omnion	Dismantled	Peak Shaving, Voltage Regulation
PM250	Flooded Lead-Acid Battery	Delco-Remy	IGBT	Omnion	Product line - available	Modular Power Management System
OGELTHORP - PQ2000®	Flooded Lead-Acid Battery	Delco-Remy	IGBT	Omnion	Operational	Power Quality Application
SSD®	SMES	Superconductivity, Inc.	IGBT	-	Product line available	Power Quality
ANCHORAGE MUNICIPAL L&P	SMES	Babcock & Wilcox	-	-	To be built	Spinning Reserve, Voltage Regulation

MS-0513, R. Eagan (1000)  
MS-0953, W. Alzheimer (1500)  
MS-0702, D. Arvizu (6200)  
MS-0212, A. Phillips, (10230)  
MS-0340, J. Braithwaite (1832)  
MS-0343, W. Cieslak (1832)  
MS-0521, J. T. Cutchen (1501)  
MS-0613, A. Akhil (1525)  
MS-0613, D. Doughty (1521)  
MS-0614, E. Binasiewicz (1522)  
MS-0613, G. Corey (1525)  
MS-0614, G.P. Rodriguez, (1523)  
MS-0613, I. Francis (1525)  
MS-0614, J. Freese (1523)  
MS-0614, T. Unkelhaeuser (1523)  
MS-0614, D. Mitchell (1522)  
MS-0614, J.R. Armijo (1523)  
MS-0614, K. Grothaus (1523)  
MS-0613, N. Clark (1525)  
MS-0613 R. Jungst (1521)  
MS-0704, P. Klimas (6201)  
MS-0708, H. Dodd (6214)  
MS-0752, M. Tatro (6219)  
MS-0753, C. Cameron (6218)  
MS-0753, R. Bonn (6218)  
MS-0753, T. Hund (6218)  
MS-0753, W. Bower (6218)  
MS-1193, D. Rovang (1231)  
MS-0613, P. Butler (1525) (20)  
MS-0619, Review & Approval Desk For DOE/OSTI (12690) (2)  
MS-0899, Technical Library (4414) (5)  
MS-9018, Central Technical Files (8940-2)

ABB Power T&D Co., Inc.  
Attn: P. Danfors  
16250 West Glendale Drive  
New Berlin, WI 53151

Argonne National Laboratories (2)  
Attn: W. DeLuca  
G. Henriksen  
CTD, Building 205  
9700 South Cass Avenue  
Argonne, IL 60439

AC Battery Corporation  
Attn: R. Flemming  
2080 Energy Drive  
P.O. Box 325  
East Troy, WI 53120

Arizona Public Service (2)  
Attn: R. Hobbs  
Herb Hayden  
P.O. Box 5399  
Phoenix, AZ 85072

American Electric Power Service Corp.  
Attn: C. Shih  
1 Riverside Plaza  
Columbus, OH 43215

Lucent Technologies  
Attn: K. Bullock  
3000 Skyline Drive  
Mesquite, TX 75149

Anchorage Municipal Light & Power  
Attn: M. Aslam  
1200 East 1<sup>st</sup> Avenue  
Anchorage, AK 99501

AVO International  
Attn: Gary Markle  
510 Township Line Rd.  
Blue Bell, PA 19422

Bechtel  
Attn: W. Stolte  
P.O. Box 193965  
San Francisco, CA 94119-3965

Babcock & Wilcox  
Attn: Glenn Campbell  
P.O. Box 785  
Lynchburg, VA 24505



Berliner Kraft und Licht (BEWAG)  
Attn: K. Kramer  
Stauffenbergstrasse 26  
1000 Berlin 30  
GERMANY

California State Air Resources Board  
Attn: J. Holmes  
Research Division  
P.O. Box 2815  
Sacramento, CA 95812

Business Management Consulting  
Attn: S. Jabbour  
24704 Voorhees Drive  
Los Altos Hills, CA 94022

Calpine Corp.  
Attn: R. Boucher  
50 W. San Fernando, Ste. 550  
San Jose, CA 95113

C&D Charter Power Systems, Inc. (2)  
Attn: Dr. Sudhan S. Misra  
Attn: Dr. L. Holden  
Washington & Cherry Sts.  
Conshohocken, PA 19428

Chugach Electric Association, Inc. (2)  
Attn: T. Lovas  
J. Cooley  
P.O. Box 196300  
Anchorage, AK 99519-6300

Delphi Energy and Engine  
Management Systems (2)  
Attn: J. Michael Hinga  
R. Rider  
P.O. Box 502650  
Indianapolis, IN 46250

Consolidated Edison (2)  
Attn: M. Lebow  
N. Tai  
4 Irving Place  
New York, NY 10003

International Energy Systems, Ltd.  
Attn: G. Barker  
Chester High Road  
Nestor South Wirral  
Nestor, South Wirral  
L64 UE UK  
UNITED KINGDOM

Corn Belt Electric Cooperative  
Attn: R. Stack  
P.O. Box 816  
Bloomington, IL 61702

EA Technology, Ltd.  
Attn: J. Baker  
Chester CH1 6ES  
Capenhurst, England  
UNITED KINGDOM

East Penn Manufacturing Co., Inc.  
Attn: M. Stanton  
Deka Road  
Lyon Station, PA 19536

Eagle-Picher Industries  
Attn: J. DeGruson  
C & Porter Street  
Joplin, MO 64802

Electric Power Research Institute (3)  
Attn: S. Chapel  
S. Eckroad  
R. Schainker  
P. O. Box 10412  
Palo Alto, CA 94303-0813

Electrosources  
Attn: Michael Dodge  
P.O. Box 7115  
Loveland, CO 80537

Electrochemical Engineering Consultants, Inc.  
Attn: P. Symons  
1295 Kelly Park Circle  
Morgan Hill, CA 95037

Eltech Research Corporation  
Attn: Dr. E. Rudd  
625 East Street  
Fairport Harbor, OH 44077

Electrochemical Energy Storage Systems, Inc.  
Attn: D. Feder  
35 Ridgedale Avenue  
Madison, NJ 07940

Energetics, Inc. (4)  
Attn: J. Badin  
H. Lowitt  
P. Taylor  
L. Charles  
7164 Columbia Gateway Drive  
Columbia, MD 21046

Energy Systems Consulting  
Attn: A. Pivec  
41 Springbrook Road  
Livingston, NJ 07039

Energetics, Inc. (2)  
Attn: M. Farber  
R. Scheer  
501 School St. SW, Suite 501  
Washington, DC 20024

Exxon Research Company  
Attn: R. Bearden  
P.O. Box 536  
1900 East Linden Avenue  
Linden, NJ 07036

Energy and Environmental Economics, Inc.  
Attn: Greg J. Ball  
353 Sacramento St., Suite 1540  
San Francisco, CA 94111

Firing Circuits, Inc.  
Attn: J. Mills  
P.O. Box 2007  
Norwalk, CT 06852-2007

GE Industrial & Power Services  
Attn: Bob Zrebiec  
640 Freedom Business Center  
King of Prussia, PA 19046

General Electric Company  
Attn: N. Miller  
Building 2, Room 605  
1 River Road  
Schenectady, NY 12345

Giner, Inc.  
Attn: A. LaConti  
14 Spring Street  
Waltham, MA 02254-9147

General Electric Drive Systems  
Attn: D. Daly  
1501 Roanoke Blvd.  
Salem, VA 24153

Golden Valley Electric Association, Inc.  
Attn: S. Haagensen  
Box 71249  
758 Illinois Street  
Fairbanks, AK 99701

GNB Technologies  
World Headquarters  
Attn: S. Deshpande  
375 Northridge Road  
Atlanta, GA 30350

GNB Technologies (3)  
Industrial Battery Company  
Attn: G. Hunt  
    J. Szymborski  
    R. Maresca  
Woodlake Corporate Park  
829 Parkview Blvd.  
Lombard, IL 60148-3249

Hawaii Electric Light Co.  
Attn: C. Nagata  
P.O. Box 1027  
Hilo, HI 96720

Kenetech/Wind Power (2)  
Attn: Michael Behnke  
    W. Erdman  
6952 Preston Avenue  
Livermore, CA 94550

ILZRO (3)  
Attn: J. Cole  
    P. Moseley  
    C. Parker  
P.O. Box 12036  
Research Triangle Park, NC 27709

Lawrence Berkeley Laboratory (3)  
Attn: E. Cairns  
    K. Kinoshita  
    F. McLarnon  
University of California  
One Cyclotron Road  
Berkeley, CA 94720

Imperial Oil Resources, Ltd.  
Attn: R. Myers  
3535 Research Rd NW  
Calgary, Alberta  
CANADA T2L 2K8

Longitude 122 West  
Attn: S. Schoenung  
1241 Hobart St.  
Menlo Park, CA 94025

Innovative Power Sources  
Attn: Ken Belfer  
1419 Via Jon Jose Road  
Alamo, CA 94507

Lucas Controls, Inc.  
Attn: Donald J. Lucas  
10925 Miller Rd., Ste. A  
Dallas, TX 75355-1848

J. Meglen  
P.O. Box 3232  
Oakton, VA 22124

National Renewable Energy Laboratory (5)

Attn: R. McConnell

L. Flowers

J. Green

S. Hock

R. DeBlasio

1617 Cole Blvd.

Golden, CO 80401-3393

Metlakatla Power & Light

Attn: H. Achenbach

P.O. Box 359

Metlakatla, AK 99926

New York Power Authority

Attn: B. Chezar

1633 Broadway

New York, NY 10019

Micron Corporation

Attn: D. Nowack

158 Orchard Lane

Winchester, TN 37398

Northern States Power

Attn: D. Zurn

414 Nicollet Mall

Minneapolis, MN 55401

ZBB, LTD.

Attn: Robert J. Parry

P.O. Box 1410, West Perth

Western Australia 6872

NPA Technology

Attn: Jack Brown

Suite 700, Two University Place

Durham, NC 27707

Oglethorpe Power Company

Attn: C. Ward

2100 E. Exchange Place

P.O. Box 1349

Tucker, GA 30085-1349

Oak Ridge National Laboratory (3)

Attn: B. Hawsey, Bldg. 3025, MS-6040

J. Stoval, Bldg. 3147, MS-6070

J. VanCoevering, Bldg. 3147, MS-6070

P.O. Box 2008

Oak Ridge, TN 37831

Omnion Power Engineering Corporation

Attn: H. Meyer

2010 Energy Drive

P.O. Box 879

East Troy, WI 53120

PEPCO  
Attn: John Young  
1900 Pennsylvania NW, Room 842  
Washington, DC 20068

Orion Energy Corp.  
Attn: Doug Danley  
18131 Metz Dr.  
Germantown, MD 20874

Power Engineers, Inc. (2)  
Attn: Timothy Ostermeter  
S. Sostrom  
P.O. Box 1066  
Hailey, ID 83333

Endecon Engineering  
Attn: Rick Winter  
Research Engineer  
2500 Old Crow Canyon Rd., Suite 220  
San Ramon, CA 94583

Power Technologies, Inc.  
Attn: P. Prabhakara  
1482 Erie Blvd.  
P.O. Box 1058  
Schenectady, NY 12301

Pacific Gas & Electric  
Attn: B. Norris  
2303 Camino Ramon, Suite 200  
San Ramon, CA 94583

Power Technologies, Inc.  
Attn: H. Clark  
775 Sunrise Ave.  
Suite 210  
Roseville, CA 95661

Pacific Northwest Laboratory (2)  
Attn: J. DeSteeze, K5-02  
D. Brown  
Battelle Blvd.  
Richland, WA 99352

Powercell Corporation  
Attn: Reznor I. Orr  
One Memorial Drive  
Cambridge, MA 02142

Puerto Rico Electric Power Authority  
Attn: W. Torres  
G.P.O. Box 4267  
San Juan, Puerto Rico 00936-426

Public Utility Commission of Texas  
Attn: D. Jaussaud  
7800 Shoal Creek Blvd.  
Austin, TX 78757

Raytheon Engineers and Constructors  
Attn: A. Randall  
700 South Ash St.  
P.O. Box 5888  
Denver, CO 80217

RMS Company  
Attn: K. Ferris  
87 Martling Ave.  
Pleasantville, NY 10570

R&D Associates  
Attn: J. Thompson  
2100 Washington Blvd.  
Arlington, VA 22204-5706

Sacramento Municipal Utility District  
Attn: Robert P. Wichert  
P.O. Box 15830  
Sacramento, CA 95817

Sentech Inc. (3)  
Attn: R. Sen  
S. Swaminathan  
K. Klunder  
4733 Bethesda Avenue, Suite 608  
Bethesda, MD 20814

SAFT Research & Dev. Ctr.  
Attn: Guy Chagnon  
107 Beaver Court  
Cockeysville, MD 21030

Sentech Inc.  
Attn: Robert Reeves  
9 Eaton Road  
Troy, NY 12180

Salt River Project (2)  
Attn: H. Lundstrom  
G.E. "Ernie" Palomino, P.E.  
MS PAB 357, Box 52025  
Phoenix, AZ 85072-2025

Santa Clara University  
Attn: Charles Feinstein, Ph.D.  
Department of Decision and Information Sciences  
Leavey School of Business and Administration  
Santa Clara, CA 95053



State of Alaska  
Dept. of Community & Regional Affairs  
Attn: Afzal H. Khan  
333 W. 4th Avenue, Suite 220  
Anchorage, AK 99501-2341

SEIA (2)  
Attn: S. Sklar  
Clay Aldrich  
122 C Street NW  
4<sup>th</sup> Floor  
Washington, DC 20001-2104

Soft Switching Technologies  
Attn: D. Divan  
2224 Evergreen Rd., Ste. 6  
Middleton, WI 53562

SRI International  
Attn: C. Seitz  
333 Ravenswood Ave.  
Menlo Park, CA 94025

Solarex  
Attn: G. Braun  
630 Solarex Court  
Frederick, MD 21701

Stored Energy Engineering  
Attn: George Zink  
7601 E 88<sup>th</sup> Place  
Indianapolis, IN 46256

Southern California Edison (3)  
Attn: R. N. Schweinberg  
J. Leeper  
N. Pinsky  
6070 N. Irwindale Ave., Suite I  
Irwindale, CA 91702

Stuart Kuritzky  
347 Madison Avenue  
New York, NY 10017

U.S. Department of Energy  
Attn: A. Landgrebe  
Office of Transportation Technologies  
EE-32 FORSTL  
Washington, DC 20585

Superconductivity, Inc. (2)  
Attn: Jennifer Billman  
Michael Gravely  
P.O. Box 56074  
Madison, WI 53705-4374

U.S. Department of Energy  
Attn: R. Brewer  
Office of Energy Management  
EE-12 FORSTL  
Washington, DC 20585

Switch Technologies  
Attn: J. Hurwitch  
4733 Bethesda Ave., Ste. 608  
Bethesda, MD 20814

U.S. Department of Energy  
Attn: N. Rossmeissl  
Office of Energy Management  
EE-12 FORSTL  
Washington, DC 20585

U.S. Department of Energy  
Attn: P. Patil  
Office of Transportation Technologies  
EE-32 FORSTL  
Washington, DC 20585

U.S. Department of Energy  
Attn: J. P. Archibald  
EE FORSTL  
Washington, DC 20585

U.S. Department of Energy  
Attn: T. Duong  
Office of Transportation Technologies  
EE-32 FORSTL  
Washington, DC 20585

U.S. Department of Energy  
Attn: M. B. Ginsberg  
EE FORSTL  
Washington, DC 20585

U.S. Department of Energy  
Attn: J. Daley  
Office of Energy Management  
EE-12 FORSTL  
Washington, DC 20585

U.S. Department of Energy  
Attn.: G. Buckingham  
Albuquerque Operations Office  
Energy Technologies Division, P.O. Box 5400  
Albuquerque, NM 87115

U.S. Department of Energy  
Attn: A. Jelacic  
Office of Energy Management  
EE-12 FORSTL  
Washington, DC 20585

TU Electric  
R&D Programs  
Attn: James Fangué  
1601 Bryan St., Rm 19030  
Dallas, TX 75201

U.S. Department of Energy  
Attn: A. G. Crawley  
EE FORSTL  
Washington, DC 20585

University of Missouri - Rolla  
Attn: M. Anderson  
112 Electrical Engineering Building  
Rolla, MO 65401-0249

U.S. Department of Energy  
Attn: P. N. Overholt  
EE-141 FORSTL  
Washington, DC 20585

U.S. Department of Energy  
Attn: R. Eynon  
Nuclear and Electrical Analysis Branch  
EI-821 FORSTL  
Washington, DC 20585

U.S. Department of Energy  
Attn: D. A. Sanchez  
Kirtland Area Office  
P. O. Box 5400  
Albuquerque, NM 87185-5400

U.S. Department of Energy  
Attn: A. Hoffman  
Office of Utility Technologies  
EE-10 FORSTL  
Washington, DC 20585

U.S. Department of Energy  
Attn.: D. Eckelkamp-Baker  
Albuquerque Operations Office  
Energy Technologies Division, P.O. Box 5400  
Albuquerque, NM 87115

U.S. Department of Energy  
Attn: R. Eaton III  
Golden Field Office  
1617 Cole Blvd.  
Building 17  
Golden, CO 80401

Virginia Power  
Attn: Gary Verno  
Innsbrook Technical Center  
5000 Dominion Boulevard  
Glen Ellen, VA 23233

U.S. Department of Energy  
Attn: C. Platt  
Office of Energy Management  
EE-12 FORSTL  
Washington, DC 20585

Walt Disney World Design and Eng'g.  
Attn: Randy Bevin  
P.O. Box 10,000  
Lake Buena Vista, FL 32830-1000

Westinghouse  
Attn: Tom Matty  
P.O. Box 17230  
Baltimore, MD 21023

R. Weaver  
777 Wildwood Lane  
Palo Alto, CA 94303

Westinghouse STC  
Attn.: H. Saunders  
1310 Beulah Road  
Pittsburgh, PA 15235

Yuasa-Exide Inc. (3)  
Attn: N. Magnani  
F. Tarantino  
G. Cook  
2400 Bernville Road  
Reading, PA 19605

W. R. Grace & Company  
Attn.: S. Strzempko  
62 Whittemore Avenue  
Cambridge, MA 02140

The Technology Group Inc.  
Attn: Tom Anyos  
63 Linden Ave.  
Atherton, CA 94027-2161

Yuasa-Exide Inc.  
Attn: W. Baumann  
32 Allen Lane  
Mt. Kisco, NY 10549

Zaininger Engineering Co., Inc.  
Attn.: H. Zaininger  
1590 Oakland Road, Suite B2111  
San Jose, CA 95131

Crescent EMC  
Attn: R. B. Sloan  
Executive Vice President  
P.O. Box 1831  
Statesville, NC 28687

ZBB Battery Technologies, Inc.  
Attn: P. Eidler  
11607 West Dearborn  
Wauwatosa, WI 53226-3961

HL&P Energy Services  
Attn: George H. Nolin, CEM, P.E.  
Product Manager Premium Power Services  
P.O. Box 4300  
Houston, TX 77210-4300

Public Utility Commission of Texas  
Attn: Danielle Jaussaud  
Competitive Issues Division  
7800 Shoal Creek Boulevard  
Austin, TX 78757

UFTO  
Attn: Edward Beardsworth  
951 Lincoln Ave.  
Palo Alto CA 94301-3041

ECG Consulting Group Inc.  
Attn: Daniel R. Bruck  
Senior Associate  
55-6 Woodlake Road  
Albany, NY 12203

Distributed Utilities Associates  
Attn: Joseph Ianucci  
3470 Crow Canyon Suite 140  
San Ramon, CA 94583

Westinghouse Electric Corporation  
Attn: Gerald J. Keane  
Manager, Venture Development  
Energy Management Division  
4400 Alafaya Trail  
Orlando, FL 32826-2399

SAFT America Inc.  
Attn: Ole Vigerstol  
National Sales Manager  
711 Industrial Blvd.  
Valdosta, GA 13601

The Brattle Group  
Attn: Thomas J. Jenkin  
44 Brattle Street  
Cambridge, MA 02138-3736

American Superconductor Corporation  
Attn: S. Amanda Chiu, P.E.  
Manager, Strategic Marketing  
Two Technology Drive  
Westborough, MA 01581

Exide Electronics  
Attn: John Breckenridge  
Director, Federal Systems Division  
8609 Six Forks Road  
Raleigh, NC 27615

University of Texas at Austin  
Attn: John H. Price  
Research Associate  
Center for Electromechanics  
J. J. Pickel Research Campus  
Mail Code R7000  
Austin, TX 78712

Northern States Power Company  
Attn: Gary G. Karn, P.E.  
Consultant Electric Services  
1518 Chestnut Avenue North  
Minneapolis, MN 55403

U.S. Department of Energy  
Attn: J. E. Rannels  
Photovoltaic Division  
EE-11 FORSTL  
Washington, DC 20585

Frost & Sullivan (2)  
Attn: Steven Kraft  
Dave Coleman  
2525 Charleston Road  
Mountain View, CA 94043

U.S. Department of Energy  
Attn: W. Butler  
PA-3 FORSTL  
Washington, DC 20585

C&D Powercom  
Attn: Larry S. Meisner  
Manager Product Marketing  
1400 Union Meeting Road  
P.O. Box 3053  
Blue Bell, PA 19422-0858

U.S. Department of Energy  
Attn: J. A. Mazer  
Photovoltaic Division  
EE-11 FORSTL  
Washington, DC 20585

Tampa Electric Company  
Attn: Terri Hensley, Engineer  
P.O. Box 111  
Tampa, FL 33601-0111



VEDCO Energy  
Attn: Rick Ubaldi  
12 Agatha Lane  
Wayne, New Jersey 07470

U.S. Department of Energy  
Attn: R. J. King  
Photovoltaic Division  
EE-11 FORSTL  
Washington, DC 20585

U.S. Department of Energy  
Attn: A. O. Bulawka  
Photovoltaic Division  
EE-11 FORSTL  
Washington, DC 20585

U.S. Department of Energy  
Attn: D. T. Ton  
Photovoltaic Division  
EE-11 FORSTL  
Washington, DC 20585