

CONF-970469--4

SA 1096-2307C

RECEIVED

Miniature Autonomous Robotic Vehicle (MARV) SEP 26 1996

OSTI

John T. Feddema, Kwan S. Kwok, Brian J. Driessen, Barry L. Spletzer, Thomas M. Weber*

MASTER

Sandia National Laboratories
P.O. Box 5800, MS 1003
Albuquerque, NM 87185

Abstract

Sandia National Laboratories (SNL) has recently developed a 16 cm³ (1 in³) autonomous robotic vehicle which is capable of tracking a single conducting wire carrying a 96kHz signal. This vehicle was developed to assess the limiting factors in using commercial technology to build miniature autonomous vehicles. Particular attention was paid to the design of the control system to search out the wire, track it, and recover if the wire was lost. This paper describes the test vehicle and the control analysis. Presented in the paper are the vehicle model, control laws, a stability analysis, simulation studies and experimental results.

1. Introduction

Microrobotic systems have many potential applications both on land and in space. For years, researchers have suggested the possibility of minute robotic systems at the cellular level that would travel throughout the blood stream and repair clogged arteries [1][2]. The military envisions miniature robotic systems which can be used to assist soldiers in the field for surveillance and inspection; searching, following and tagging; and locating and identifying targets. Microrobotic systems have also been envisioned as the next lunar rovers, extremely small and inexpensive to launch into space[3].

Recently, several miniature robotic systems have been built to test system components

and the feasibility of controlling these devices. Brooks is probably the most famous for developing spider-like robots and a layered control system called the Subsumption Architecture [4]. Additionally, Hasslacher and Tilden constructed and experimented with several mechanical systems that are not designed to perform a set of goal oriented tasks, or work, but rather to express modes of survival behavior [5].

Ferrell conducted work on a six-legged spider-like autonomous robot that weighs six pounds [6]. This six-legged robot had more than 100 sensors and eight on-board computers. These sensors included leg-mounted force sensors, joint angle sensors, joint velocity sensors, ground-contact sensors, range sensors (up to 0.3m), actuated antennae, and IR-range finder (up to 3m). Also, space was allotted on the robot for a visible-light camera and color sensors. The Subsumption Architecture was also used for the autonomous control. The redundant sensors were used to make the robot more robust to failed sensors.

Isihari and Fukuda designed and built a 1 cm³ prototype car-like mobile autonomous Micro Line Trace Robot [7]. However, it was never rendered operational because of the lack of a small enough battery to simultaneously fit in the vehicle and drive the electromagnetic mobile actuator, although some successful line tracking experiments were performed with wires connected from a power source to the robot.

DISTRIBUTION OF THIS DOCUMENT IS UNLIMITED

* This work performed at Sandia National Laboratories supported by the U.S. Department of Energy under contract DE-AC04-94AL85000.

DISCLAIMER

This report was prepared as an account of work sponsored by an agency of the United States Government. Neither the United States Government nor any agency thereof, nor any of their employees, make any warranty, express or implied, or assumes any legal liability or responsibility for the accuracy, completeness, or usefulness of any information, apparatus, product, or process disclosed, or represents that its use would not infringe privately owned rights. Reference herein to any specific commercial product, process, or service by trade name, trademark, manufacturer, or otherwise does not necessarily constitute or imply its endorsement, recommendation, or favoring by the United States Government or any agency thereof. The views and opinions of authors expressed herein do not necessarily state or reflect those of the United States Government or any agency thereof.

DISCLAIMER

Portions of this document may be illegible in electronic image products. Images are produced from the best available original document.

Also, Buchi et al. built a fully autonomous mini-mobile robot with dimensions 20mm X 8mm X 15mm [8]. Watch motors were used as actuators, and the gears of the second hand used as wheels. A low power consumption rate of 6mW was attained, allowing the robot to move autonomously for 8-10 hours.

The development of MARV was conceived at SNL as a demonstration project in which commercially available components were integrated onto an in-house custom designed chassis to form an autonomous mobile vehicle. The proposed task for MARV is to intercept and then track a wire carrying a fixed frequency. This paper first describes the hardware construction of the vehicle. Next, the model used to develop the controller and the actual control approach embedded in the microcontroller are presented. A stability analysis is included because we observed different responses from the vehicle depending on the sensor locations. This is also addressed in both the simulation studies and the experiments that are described in the remaining sections of the paper.

2. Hardware Platform

Sandia's vehicle consists of a 23.4 x 15.9 x 24.1 mm lexan frame which holds two Micro Mo 0816-008S DC motors, two 3 volt lithium cells, a Microchip PIC16LC71-04/SO microcontroller, two 4.4 x 8.9 mm printed circuit antennas, and electronics for conditioning the antennae signal and driving the motors (see Figure 1). The vehicle has four wheels. Each rear wheel has a separate drive motor and a 15:1 worm reducer. The two antennas on the bottom of the vehicle are used to detect whether the vehicle's centerline is to the right or left of the wire containing the tracking signal.

A printed circuit board on the bottom of the vehicle contains the two antennas on one side and the signal conditioning electronics on the other side. The electronics consist of a charge amplifier and active bandpass filter (see Figure 2 at the end of the paper). The signals from this board go to a microcontroller board on the top of the vehicle.

The microcontroller board is also a double sided printed circuit board with a signal rectifier and gain stage on one side and the microcontroller and motor amplifiers on the other side (see Figure 3 at the end of the paper). The microcontroller reads the sensor signals and outputs PWM (Pulse Width Modulated) signals to two sets of H-bridge amplifiers which drive the two motors. The H-bridge is formed with eight surface mount transistors and allows the wheels to be driven both forward and backward. The duty cycle of each PWM signal is proportional to each wheel's rotational velocity. The control sampling frequency of the microcontroller is 100Hz.

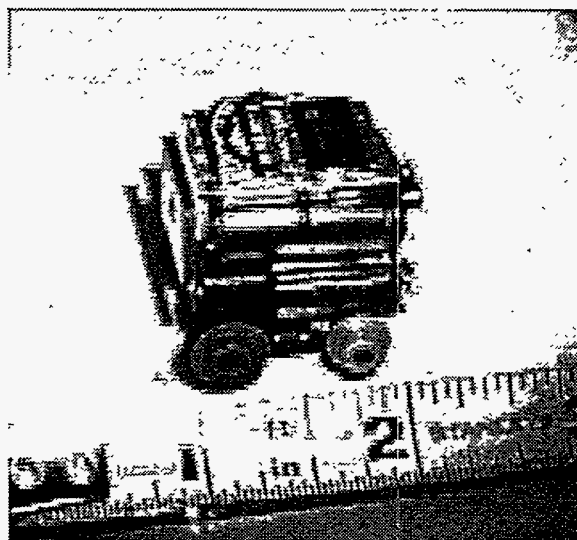

Figure 1. Picture of MARV

Approximately 300 lines of assembly code were written to control the vehicle. A set of if/then statements in the embedded software jump between four finite states: SEARCH, ROTATE, TRACK, and BACKUP. Changing from one state to another depends on the current state the program is in and the two sensor values. Based on the state decision, the program jumps to different routines which determine the PWM signals that control the velocities of the two motors. During these routines, the state and time in that state are updated, and each routine ends by going back and reading the sensor inputs. This organization resembles an augmented finite state machine. Similar to the work by Brooks, there is a time out associated with

each state; however, we do not compute the results of each state in parallel and then decide which state to apply.

3. Theory

The following three subsections discuss a model of the vehicle, the control used to guide it, and the stability of the control. The stability of the control is important because it is directly related to the vehicle design. In particular, the positioning of the sensors under the vehicle directly affects the controls and the stability of the system.

3.1 Model

A simple model of the vehicle is shown in Figure 4. Frame 0 is fixed to the ground. Frame 1 is fixed to the car. Let R denote the distance from point A to point B. Let u_1 be the velocity of the first driving wheel (at point A), and u_2 the velocity of the second wheel (at point B). Both u_1 and u_2 are measured in the \bar{i}_1 direction. Let x and y denote the position of point C relative to frame 0. Let θ denote the angle of the car, measured from \bar{i}_0 to \bar{i}_1 . The first sensor is at $a\bar{i}_1 + b\bar{j}_1$ and the second one at $a\bar{i}_1 - b\bar{j}_1$, as illustrated in Figure 4.

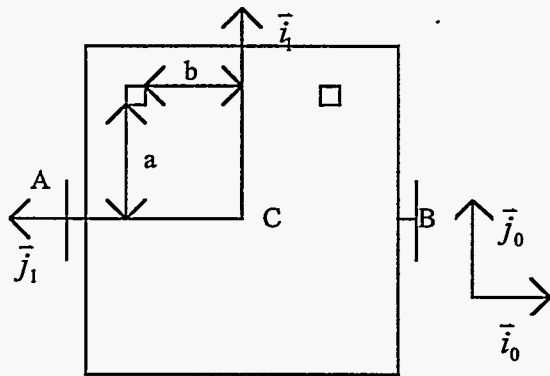

Figure 4. Model of Vehicle

The first order model of the vehicle plant is:

$$\dot{x} = \frac{1}{2}(u_1 + u_2) \cos \theta \quad (1)$$

$$\dot{y} = \frac{1}{2}(u_1 + u_2) \sin \theta \quad (2)$$

$$\dot{\theta} = \frac{1}{R}(-u_1 + u_2) \quad (3)$$

The two sensors are modeled by the free space propagation model of a transmitter-receiver pair, which is

$$P_r = \frac{P_t A_t A_r f^2}{c^2 d^2 L}$$

where P_r and P_t are the received and transmitted power, A_t and A_r are the effective aperture of the transmitter and receiver, f is the carrier frequency in Hertz, c is the speed of light, d is the distance between the transmitter and receiver, and L is the system loss factor not related to propagation ($L \geq 1$). The effective aperture is related to the physical size of the antenna. In our case, P_t , A_t , A_r , f , and L are constant. Therefore, the two antenna sensors on the bottom of the vehicle will ultimately provide a signal given by:

$$\text{sensor1} = \frac{\tilde{k}_1}{d_1^2} \quad (4)$$

$$\text{sensor2} = \frac{\tilde{k}_2}{d_2^2} \quad (5)$$

where d_1 is the distance of sensor1 from the line to be tracked and d_2 that of sensor2, and \tilde{k}_1 and \tilde{k}_2 are constants.

3.2. Wire-Tracking Control

The objective of the controller for wire-tracking is to track the wire given only the sensor feedback of equations (4) and (5). As mentioned in Section 2, the proposed control law consists of four finite states: SEARCH, ROTATE, TRACK, and BACKUP. After both sensor1 and sensor2 are read with the microcontroller's analog-to-digital converter, the following decisions are made.

```

if (state == SEARCH)
  if ( sensor1 > THRESHOLD2
  or sensor2 > THRESHOLD2)
    Goto ROTATE
    routine and change
    state to ROTATE.
else
  
```

```

        Goto search routine
        and stay in SEARCH
        state.
    endif
else if ( state == ROTATE )
    if ( sensor1 < THRESHOLD2
    or sensor2 < THRESHOLD2)
        Goto TRACK routine
        and change state to
        TRACK.
    else
        Goto rotate routine
        and stay in ROTATE
        state.
    endif
else if (state == TRACK)
    if ( sensor1 > THRESHOLD
    or sensor2 > THRESHOLD)
        Goto TRACK routine
        and stay in TRACK
        state.
    else
        Goto BACKUP
        routine and change
        state to BACKUP.
    endif
else if ( state == BACKUP )
    if ( sensor1 > THRESHOLD2
    or sensor2 > THRESHOLD2)
        Goto TRACK routine
        and change state to
        TRACK.
    else if ( statetime > RESETTIME )
        Goto search routine
        and change state to
        SEARCH.
    else
        Goto BACKUP
        routine and change
        state to BACKUP.
    endif
endif
endif

```

The vehicle starts in SEARCH state and stays there until one of the sensors is directly over the wire (sensor1 or $\text{sensor2} > \text{THRESHOLD2}$); in which case, it will change to the ROTATE state. The vehicle will rotate as long as both sensors are directly over the wire. Otherwise, it will go to the TRACK state. Here, the vehicle will track the wire using a proportional control law explained below. If both of the sensors falls below the THRESHOLD (where $\text{THRESHOLD} < \text{THRESHOLD2}$), the vehicle goes into backup mode. The vehicle backs up until it is over the wire (THRESHOLD2) or the state time exceeds a fixed value. If the wire is found, it will go

back to the TRACK state. If RESETTIME is exceeded, it will go back into the SEARCH state.

The routines which make up the control logic in each state is shown below. Each routine ends by updating the state and statetime and jumping to the routine which reads the analog-to-digital converter for the new sensor values.

SEARCH routine:

```

Move both wheels forward at a
constant velocity SEARCH_SPEED.
Update state and statetime.
Goto Read_AD.

```

ROTATE routine:

```

Move left wheel forward and
right wheel backward at
constant velocity
ROTATE_SPEED.
Update state and statetime.
Goto Read_AD

```

TRACK routine:

```

if ( sensor1 < sensor2)
     $u_1 = \bar{u} - G(\text{sensor1} - \text{sensor2}).$ 
     $u_2 = \bar{u}.$ 
else
     $u_1 = \bar{u}.$ 
     $u_2 = \bar{u} + G(\text{sensor2} - \text{sensor1}).$ 
endif
Update state and statetime.
Goto Read_AD

```

BACKUP routine:

```

Move both wheels backward at
constant velocity BACKUP_SPEED.
Update state and statetime.
Goto Read_AD

```

The variable G is a positive control gain which was experimentally determined. For ease of implementation in the microcontroller, the gain is a power of two, allowing a simple shift of the error term.

3.3. Stability (Sensor in Front or Back)

Originally, the vehicle was intended to have the drive wheels in front of the sensors. However, we soon found that the vehicle went unstable when using the control given in the TRACK routine. The same control

was stable if the drive wheels were in back of the sensors. The following analysis was performed to understand why.

We will consider tracking a straight line $y=0$. Linearizing the plant about the trajectory $\bar{y} = 0$, $\bar{\theta} = 0$, $\bar{x} = x(0) + \bar{u}t$, $u_1 = \bar{u}$, $u_2 = \bar{u}$, we obtain

$$\Delta \dot{y} = \bar{u} \Delta \theta \quad (6)$$

$$\Delta \dot{\theta} = \frac{1}{R} (-\Delta u_1 + \Delta u_2) \quad (7)$$

From the definitions of the tracking controller,

$$-u_1 + u_2 = -G(\text{sensor1} - \text{sensor2}) \quad (8)$$

The y positions of sensor1 and sensor2 are:

$$y_1 = a \sin \theta + b \cos \theta + y \quad (9)$$

$$y_2 = a \sin \theta - b \cos \theta + y \quad (10)$$

Assuming that $\tilde{k}_1 = \tilde{k}_2 = \tilde{k}$ in (4) and (5), (8) becomes

$$-u_1 + u_2 = G\tilde{k} \left(\frac{1}{y_1^2} - \frac{1}{y_2^2} \right) \quad (11)$$

Linearizing (11) about the nominal trajectory gives

$$-\Delta u_1 + \Delta u_2 = \frac{-4G\tilde{k}a}{b^3} \Delta \theta + \frac{-4G\tilde{k}}{b^3} \Delta y \quad (12)$$

Substituting (12) into the linearized plant gives

$$\begin{pmatrix} \Delta \dot{y} \\ \Delta \dot{\theta} \end{pmatrix} = A \begin{pmatrix} \Delta y \\ \Delta \theta \end{pmatrix} \quad (13)$$

where

$$A_{11} = 0 \quad (14)$$

$$A_{12} = \bar{u} \quad (15)$$

$$A_{21} = \frac{-4G\tilde{k}}{Rb^3} \quad (16)$$

$$A_{22} = \frac{-4G\tilde{k}a}{Rb^3} \quad (17)$$

The characteristic equation is:

$$s^2 - (A_{11} + A_{22})s + (A_{11}A_{22} - A_{12}A_{21}) = 0 \quad (18)$$

and it is well known that stability for a second order system occurs if and only if

$$-(A_{11} + A_{22}) \geq 0 \quad (19)$$

and

$$A_{11}A_{22} - A_{12}A_{21} \geq 0 \quad (20)$$

Equation (19) gives

$$\frac{4G\tilde{k}a}{Rb^3} \geq 0 \quad (21)$$

and Equation (20) gives

$$\frac{4G\tilde{k}\bar{u}}{Rb^3} \geq 0 \quad (22)$$

Assuming that $b \geq 0$ (the sensors are not switched), Equation (21) is true if $a \geq 0$ and false if $a < 0$, while (22) holds for all a . So, stability of the wire tracking occurs if and only if $a \geq 0$. In other words, stable line tracking requires that the sensors be ahead of the driving wheels.

4. Simulation and Experiment

Both simulations and actual experiments were performed to test the performance of the controller. Figure 5 shows the performance of the vehicle as it approached the wire with an initial angle of 24 degrees. As the vehicle approaches the wire, it only briefly enters into the ROTATE state and then immediately enters the TRACK state. The vehicle first swerves to the right because the value of sensor2 is greater than sensor1. As the vehicle passes the wire, the value of sensor1 will be greater than sensor2 causing it to turn left. Once straddling the wire, perfect tracking is achieved.

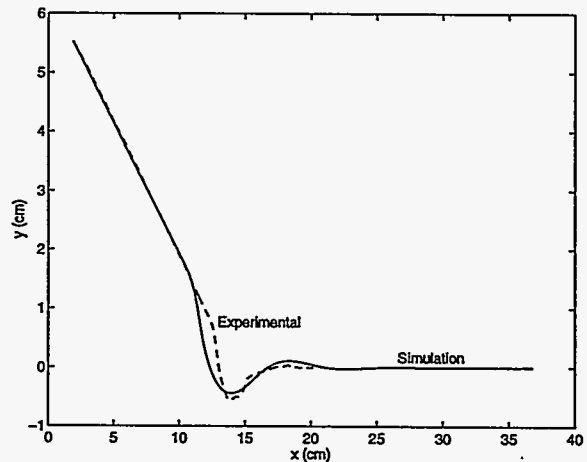

Figure 5. Path of the vehicle with a 24 degree approach. The dashed line is the experimental results, and the solid line is the simulated results.

As the vehicle approaches the wire from a more perpendicular angle, the controller will stay in the ROTATE state longer causing the vehicle to make a near right angle turn. However, as the batteries wear down, the sensor signal doesn't reach THRESHOLD2 as repeatably and the ROTATE state is once again visited only briefly. In this case, the vehicle can not make the full 90 degree turn while in the TRACK state. The vehicle passes the wire and goes into the BACKUP state. The vehicle backs into the wire and goes into the TRACK state. This sequence of TRACK and BACKUP is repeated until the vehicle is on the wire and tracks accurately. Figure 6 shows the experimental performance of the vehicle as it approaches the wire at a 52 degree angle. The jagged lines at the bottom of the curve show the vehicle switching between the TRACK and BACKUP states.

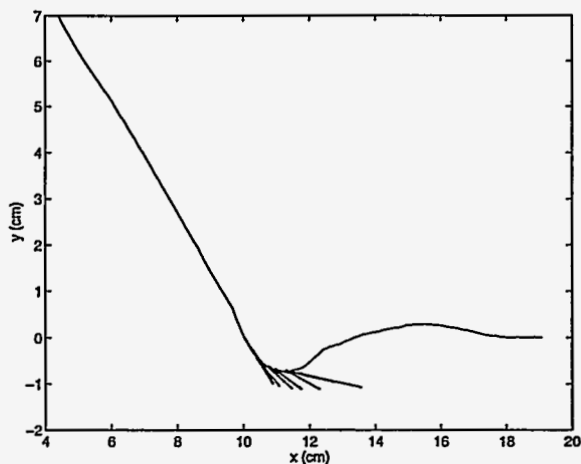

Figure 6. Path of the vehicle when approached at a 52 degree angle and when the batteries are weak.

Several observations were made during the experiments which would improve the performance of a next generation vehicle. First, the vehicle did not have encoder feedback at the wheels; thus, the control of the drive wheel velocities in the SEARCH, ROTATE, and BACKUP states was open loop. Sometimes friction in the drive train caused one wheel to move faster than the other while in the SEARCH and BACKUP state, resulting in vehicle not following in a straight line. Even without velocity

feedback at the wheels, the vehicle would reliably follow the wire in the TRACK state because the antenna sensors provided the feedback.

Second, the vehicle's traction was an issue. Too much traction on the front wheels made it difficult to turn. Ideally, the vehicle should have it's weight centered on the rear drive wheels with omni-directional coast wheels used in the front and back of the drive wheels. Traction will be an even more difficult problem as the weight of the vehicle decreases in future designs.

Third, we found that the size of the motors and batteries were the major limiting factors in reducing the size below 1 in³. Future work is needed to miniaturize these components. The next step in miniaturizing the electronics would involve fabricating the conditioning electronics into an ASIC and packaging the die of the ASIC and the die of the microcontroller onto a single board.

5. Conclusion

This paper described a miniature autonomous robotic vehicle capable of tracking a wire with a fixed frequency signal. A detailed control analysis was developed to evaluate how this goal could be achieved. This control analysis also affected the design of the vehicle and the placement of sensors. A simple augmented finite state machine was used to switch between different control states. What still needs to be further understood is how the combination of several states (e.g. TRACK and BACKUP states) can drive the plant toward its goal. We believe that future work in this area should look at variable structure control and sliding mode control analysis to evaluate this phenomenon.

References

- [1] Feynman, R., "There is Plenty of Room at the Bottom," *Miniaturization*, ed. Gilbert, H.D., Reinhold, New York, 1961, pp. 282-296.
- [2] Drexler, "Molecular Engineering: An Approach to the Development of General Capabilities for Molecular Manipulation," *Proc. Natl. Acad. Sci.*, 78:5275-5258, 1981.
- [3] Brooks, R.A., and Flynn, A.M., "Fast, Cheap, and Out of Control: A Robot Invasion of the Solar System," *Journal of the British Interplanetary Society*, Vol. 42, pp. 478-485, 1989.
- [4] Brooks, R.A., "A Robust Layered Control System for a Mobile Robot," *IEEE Journal of Robotics and Automation*, RA-2, pp. 14-23, April 1986.
- [5] Hasslacher, B., and Tilden, M.W., "Living Machines," Bio-Mechatronics Workshop held in IEEE International Conference on Robotics and Automation, pp. 70-106, April 1996.
- [6] Ferrell, C.A., "An Autonomous Mobile Robot, a Planetary Microrover," *Sensors*, February, pp. 37-47, 1994.
- [7] Ishihara, H., and Fukuda, T. "Micro Autonomous Robotic System," *Proc. SPIE - The International Society for Optical Engineering - Microrobotics and Mechanical Systems*, Vol. 2593, pp. 32-37.
- [8] Buchi, R., Rohrer, D., Schmid, C., Siegwart, R., "A Fully Autonomous Mobile Mini-Robot," *Proc. SPIE - The International Society for Optical Engineering - Microrobotics and Mechanical Systems*, Vol. 2593, pp. 50-53.

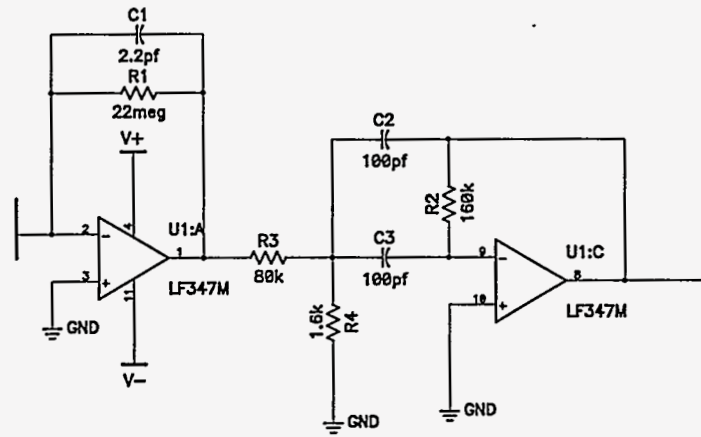

Figure 2. Schematic of one of two sensors on the sensor board.

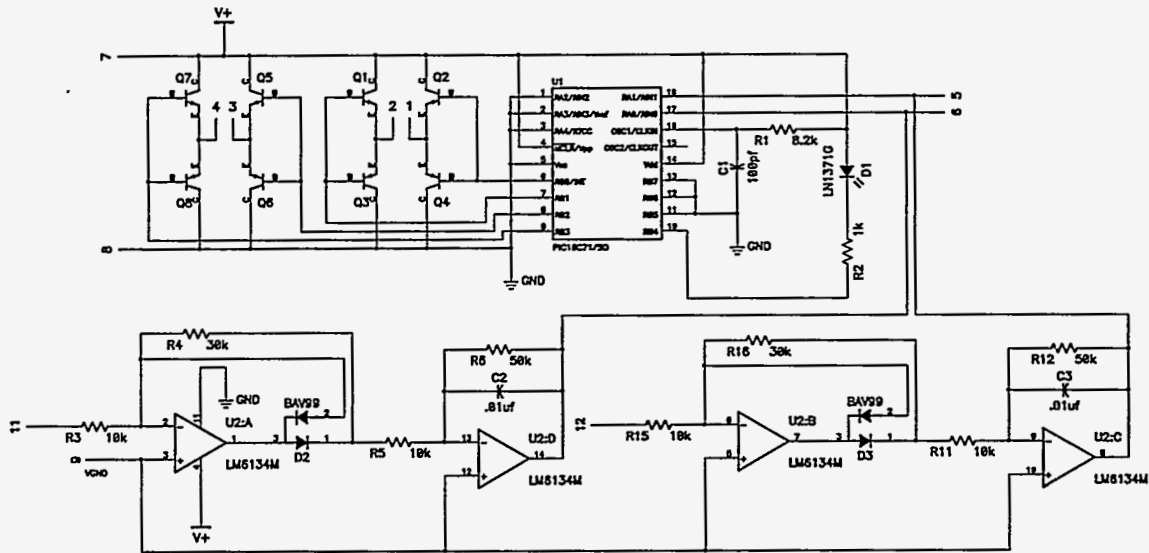

Figure 3. Schematic of microcontroller board.