

Metals and Ceramics Division

CAPSULE HRB-21 POSTIRRADIATION EXAMINATION PLAN

N. H. Packan, M. J. Kania, and L. G. Shrader

Date Published: March 1990

DISCLAIMER

This report was prepared as an account of work sponsored by an agency of the United States Government. Neither the United States Government nor any agency thereof, nor any of their employees, makes any warranty, express or implied, or assumes any legal liability or responsibility for the accuracy, completeness, or usefulness of any information, apparatus, product, or process disclosed, or represents that its use would not infringe privately owned rights. Reference herein to any specific commercial product, process, or service by trade name, trademark, manufacturer, or otherwise does not necessarily constitute or imply its endorsement, recommendation, or favoring by the United States Government or any agency thereof. The views and opinions of authors expressed herein do not necessarily state or reflect those of the United States Government or any agency thereof.

Prepared for the
U.S. Department of Energy
Office of Advanced Reactors
AF 20 10 15 2

NOTICE This document contains information of a preliminary nature. It is subject to revision or correction and therefore does not represent a final report.

Prepared by the
OAK RIDGE NATIONAL LABORATORY
Oak Ridge, Tennessee 37831-6285
operated by
MARTIN MARIETTA ENERGY SYSTEMS, INC
for the
U.S. DEPARTMENT OF ENERGY
under Contract No. DE-AC05-84OR21400

MASTER

DISTRIBUTION OF THIS DOCUMENT IS UNLIMITED

HH

DISCLAIMER

Portions of this document may be illegible in electronic image products. Images are produced from the best available original document.

CONTENTS

LIST OF FIGURES v
LIST OF TABLES vii
ACRONYMS AND ABBREVIATIONS ix
ABSTRACT 1
1. INTRODUCTION 1
 1.1 BACKGROUND 1
 1.2 SCOPE 3
2. CAPSULE DESCRIPTION 3
3. POSTIRRADIATION EXAMINATION (PIE) OBJECTIVES 6
4. QUALITY ASSURANCE 7
5. CAPSULE DISASSEMBLY 7
 5.1 TRANSFER FROM HFIR 7
 5.2 MAIN DISASSEMBLY AT HRLEL 8
6. POSTIRRADIATION EXAMINATION 13
 6.1 GAMMA SCAN 14
 6.2 VISUAL EXAMINATION 14
 6.3 CAPSULE COMPONENT AND FUEL COMPACT DIMENSIONS 14
 6.4 IRRADIATED MICROSPHERE GAMMA ANALYZER 14
 6.5 CERAMOGRAPHY 15
 6.6 ELECTRON MICROPROBE 15
 6.7 SORPTIVITY EXPERIMENT 15
 6.8 CORE CONDUCTION COOLDOWN TEST FACILITY 15
7. THERMAL ANALYSIS 16
8. STORAGE OF CAPSULE CONTENTS 16
9. DOCUMENTATION 17
10. TENTATIVE WORK SCHEDULE FOR HRB-21 PIE 17
11. REFERENCES 17
APPENDIX: Identification Code for Dosimetry
 Packets (L. R. Greenwood) 19

LIST OF FIGURES

2.1	Horizontal section through capsule HRB-21	4
2.2	Vertical section through capsule HRB-21	5
5.1	Separation of capsule from umbilical cable. Identified components are: (1) gasketed cable connector cover, (2) gas line Swagelock fitting, and (3) instrumentation Amphenol connector	7
5.2	Location for upper and lower circumferential cuts through containment (from blueprint X3E12673-0210)	9
5.3	Views of a graphite fuel body and its contents (from blueprint X3E12673-0214)	10
5.4	Views of upper insulator and coated B ₄ C specimens in their graphite tube containers (from blueprint X3E12673-0216)	12

v/ri

LIST OF TABLES

6.1 Tentative PIE test matrix for HRB-21 fuel bodies 13

6.2 Tentative CCCT matrix for HRB-21 samples 13

ACRONYMS AND ABBREVIATIONS

ANL	Argonne National Laboratory
CCCTF	Core Conduction Cooldown Test Facility
DOE	U.S. Department of Energy
FIMA	fissions per initial metal atom
GA	General Atomics
HFIR	High Flux Isotope Reactor
HRLEL	High Radiation Level Examination Laboratory
ICDM	irradiated component dimensional measurement
IMGA	irradiated microsphere gamma analyzer
JAERI	Japan Atomic Energy Research Institute
MHTGR	Modular High-Temperature Gas-Cooled Reactor
OPyC	outer pyrolytic carbon layer
ORNL	Oak Ridge National Laboratory
PIE	postirradiation examination
R/B	release-to-birth ratio for radionuclides
TCAT	thermocouple central array tube
TE	temperature element
TRISO	refers to the current design for coated particles
UCO	uranium oxycarbide

CAPSULE HRB-21 POSTIRRADIATION EXAMINATION PLAN*

N. H. Packan, M. J. Kania, and L. G. Shrader

ABSTRACT

Irradiation capsule HRB-21 is a test capsule designed to provide Modular High-Temperature Gas-Cooled Reactor (MHTGR) coated particle fuel performance data under test reactor conditions representative of normal MHTGR operation. The irradiated fuel will also be used for postirradiation heating in a controlled atmosphere allowing acquisition of fission product release data at sustained high temperatures. The in-reactor performance data, the postirradiation examination data, and the postirradiation heating data will be used for the validation of fuel performance models under normal and off-normal operating conditions. The accelerated irradiation is to take place in the High Flux Isotope Reactor (HFIR) at ORNL. This report identifies the procedures to be followed in carrying out the postirradiation disassembly and examination of HRB-21. Included is a description of the capsule, a detailed sequence of steps for disassembly of the capsule, a description of the postirradiation examination techniques to be employed, and specifications for the storage of capsule components and the reporting of results.

1. INTRODUCTION

1.1 BACKGROUND

Irradiation capsule HRB-21 is the first in a series of test capsules that are designed to provide a fuel performance database to be used for reference fuel performance demonstration under simulated Modular High-Temperature Gas-Cooled Reactor (MHTGR) normal operating conditions. Irradiation data and postirradiation examination data of the fuel particles, compacts, and graphite holders will be used to validate fuel performance models. Postirradiation tests will also be conducted in a controlled atmosphere which allows measurements of fuel failure and fission product release at sustained high temperatures. The postirradiation heating data will in turn be used to validate off-normal fuel

*Research sponsored by the Office of Advanced Reactor Programs, Division of HTGRs, U.S. Department of Energy, under contract DE-AC05-84OR21400 with Martin Marietta Energy Systems, Inc.

performance models. The HRB-21 capsule contains 24 fuel compacts of U.S. MHTGR reference quality fuel as well as a variety of encapsulated specimens related to MHTGR fuel performance, fission product transport, and control materials. The particles represent an advanced TRISO UCO/ThO₂ coated particle fuel system, incorporating an outer protective ("P") low-density pyrocarbon layer, with demonstrated low defective SiC coating fraction ($\leq 5 \times 10^{-5}$) and low heavy metal contamination fraction ($\leq 1 \times 10^{-5}$), meeting MHTGR quality specifications. The kernels and coated particles were fabricated in production-scale equipment; fuel compacts were then fabricated in laboratory-scale facilities using MHTGR reference fuel procedures at General Atomics. Nearly 150,000 fissile and fertile particles will be irradiated in capsule HRB-21 at a mean-volumetric fuel temperature of 975°C. A peak fissile burnup in excess of 24% FIMA (fissions per initial heavy metal atom) will be achieved while accumulating a maximum fast neutron fluence of about 4.5×10^{25} neutrons/m² (E>29 eV).

This experiment is part of a cooperative effort between the U.S. Department of Energy (DOE) and the Japan Atomic Energy Research Laboratory (JAERI). The participants are Oak Ridge National Laboratory (ORNL), General Atomics (GA), and the Tokai Research Establishment. Capsule HRB-21 contains the U.S. MHTGR fuel specimens; a companion capsule, HRB-22, contains the JAERI fuel.¹ The fuel performance data will be exchanged and analyses performed to broaden the technology base in support of fuel design and licensing.

The HRB-21 capsule was designed to meet the MHTGR design requirements as given in the test specification.² The primary objectives of capsule HRB-21 are to: (a) determine the performance of low-enriched uranium (LEU) coated particle fuel under normal irradiation conditions and (b) provide samples for postirradiation testing which will assist in determining the capability of the particles to meet criteria on key radionuclide release limits under accident conditions. More specific objectives under this broad heading are to:

1. Measure the release of fission gases from MHTGR reference fuel compacts during irradiation at temperatures corresponding to normal operating conditions (975°C).
2. Provide a portion of the samples needed for a series of core conduction cooldown simulation tests designed to update, as necessary, and validate the U.S. reference fuel performance model under off-normal operation conditions.
3. Provide data on irradiation-induced coating failure for potential revision of the defective particle performance models.
4. Provide irradiated unbonded particles of MHTGR reference quality for (a) direct comparison to defective particle performance in-reactor and (b) selected postirradiation investigations of the structure and performance of reference fuel.
5. Provide data on partition coefficients and diffusivity/sorptivity isotherms of Cs, Sr, I, and Ag on MHTGR core materials.

6. Provide data on the irradiation performance of both PyC-coated and PyC/SiC-coated particles containing B_4C .
7. Within the auspices of the US/FRG Umbrella Agreement for Cooperation in GCR Development, Fuel Fission Products and Graphite Subprogram, PWS-FD-25, provide significant fuel performance data for exchange with the FRG in return for the irradiation of the HFR-B1 capsule.
8. Provide performance data for comparison with that of JAERI HTTR reference fuel irradiated in capsule HRB-22.

1.2 SCOPE

This document describes the planned sequence of steps and procedures to be followed in the postirradiation disassembly and examination of capsule HRB-21. Visual examination and detailed metrology of the capsule components will provide data to be used in the postirradiation thermal analysis. Fuel particle performance will be assessed using techniques including visual examination, gamma scanning of capsule components, gamma spectrometry of individual particles with the irradiated microsphere gamma analyzer (IMGA) system, with the electron probe microanalyzer, and by metallography. Fuel performance during postirradiation heating at sustained high temperatures simulating off-normal operation will be studied using the Core Conduction Cooldown Test Facility (CCCTF). The irradiation of HRB-21 in the High Flux Isotope Reactor (HFIR) at ORNL has been covered in the HRB-21 Operating Plan.³

2. CAPSULE DESCRIPTION

The HRB-21 irradiation capsule consists of a doubly contained, single purged cell with 24 fuel compacts surrounded by H-451 graphite bodies (Fig. 2.1). The fuel compacts, three per graphite body, are composed of TRISO-coated UCO and ThO_2 particles [incorporating an outer protective ("P") low-density pyrocarbon layer] embedded in a carbonaceous matrix material. Each of the H-451 graphite fuel bodies also contains three encapsulated specimen ("piggyback") holes (Fig. 2.1). The HRB-21 Experimental Plan⁴ and the HRB-21 Preirradiation Report⁵ provide details of the fabrication and characterization of the fuel particles, fuel compacts, piggyback samples, and H-451 graphite fuel bodies.

The capsule which houses the eight H-451 graphite bodies consists of two Inconel 718 containment tubes (Fig. 2.2). Each tube is designed to independently withstand 6.9 MPa (1000 psi) inside or outside. During HFIR operation, pure helium ("secondary gas") at 4.5 MPa (650 psi) is sealed between the secondary and primary Inconel containments. A gas mixture of He and Ne ("sweep gas") at 0.07 to 0.10 MPa (10 to 15 psi) flows between the primary Inconel containment and the graphite body surface. Capsule HRB-21 has a goal volumetric fuel average temperature of 975°C. The radial gaps between the graphite fuel bodies and the primary containment

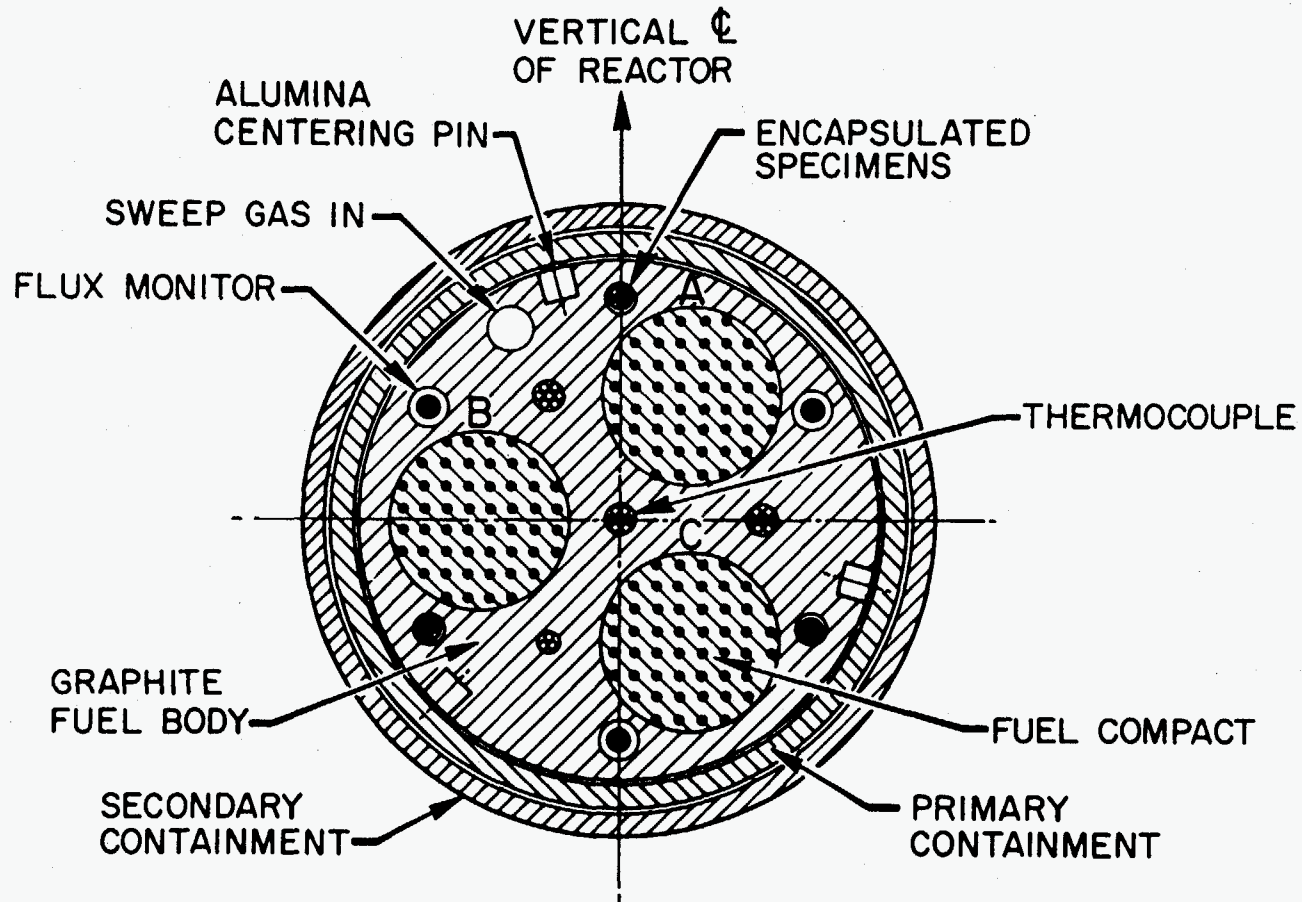

Fig. 2.1. Horizontal section through capsule HRB-21.

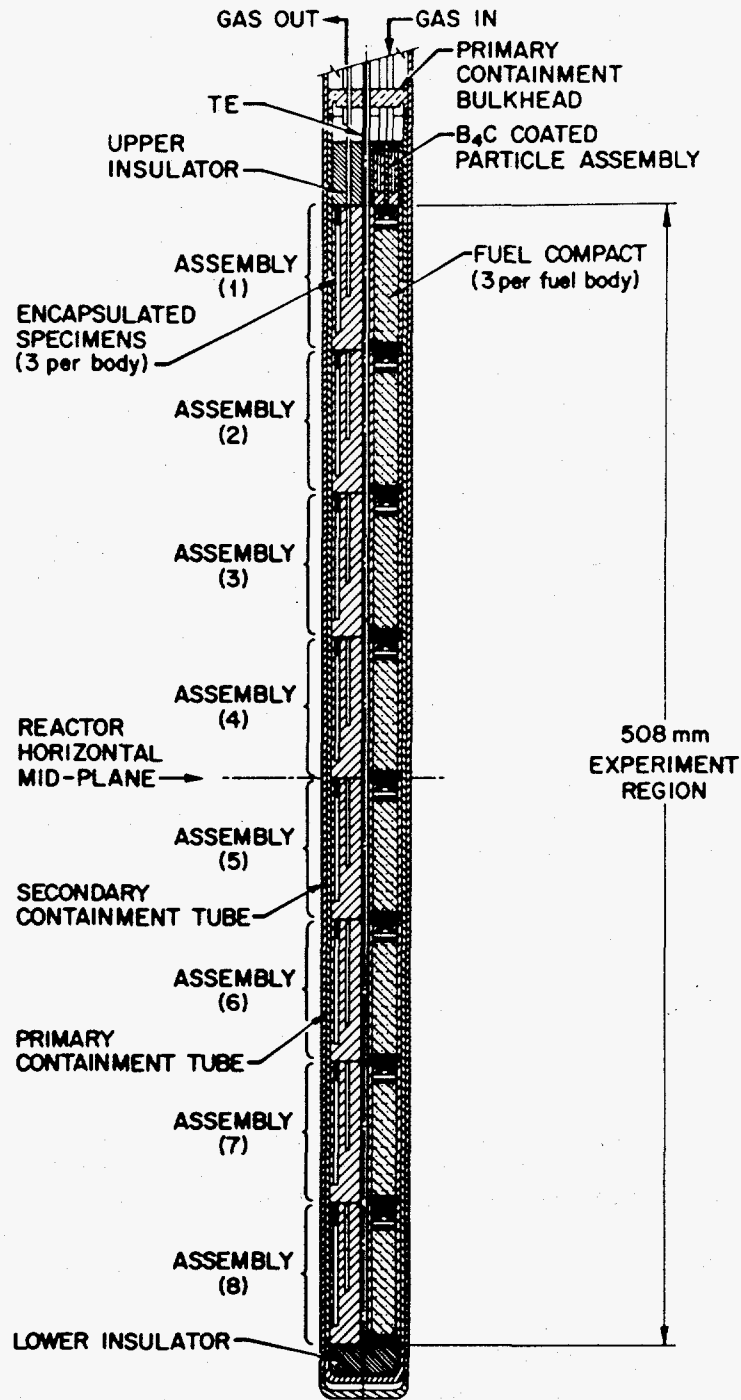

Fig. 2.2. Vertical section through capsule HRB-21.

were sized to maintain this temperature as uniformly as possible over the length of the capsule.

Three thermocouples are placed in each fuel body for a total of 24 thermocouples in the capsule. All thermocouples are MgO insulated, Inconel 601 sheathed, have insulated junctions, and are located in thermocouple central array tube (TCAT) assemblies. There are three TCAT assemblies with seven thermocouples each and one TCAT with three thermocouples. Twenty-three of the thermocouples are Chromel/Alumel (Type K), while one is Nisil/Nicrosil (Type N). Within each fuel body, the three thermocouple junctions are located as closely as possible to the axial midpoint of the 50-mm-long fuel compacts.

Dosimetry packets have been located within each HRB-21 graphite fuel body to provide measured activities that can be used to estimate neutron fluence and energy spectrum values. Each 1.6-mm-diam by 7.5-mm-long stainless steel flux monitor tube contains five precisely weighed wires, one each of Fe, Ti, Ni, Nb, and an 80.2%Mn-Cu alloy. The 26 flux monitor tubes (24 in fuel bodies plus 2 in the upper insulator) are individually etch-marked in a bar code arrangement (explained in the Appendix). They are situated in three equally spaced blind holes per graphite fuel body that place the dosimetry materials at each fuel body midplane (see Figs. 2.1 and 2.2).

3. POSTIRRADIATION EXAMINATION (PIE) OBJECTIVES

The purposes for performing the postirradiation examination of the HRB-21 capsule components, fuel samples, and encapsulated specimens are given below.

- Analysis of the dosimetry packets.
- Acquisition of precise postirradiation dimensional measurements of graphite fuel bodies and fuel compacts to aid in the final thermal analysis.
- Determination of key radionuclide release fractions for the initially unloaded fuel compacts, including both totally failed particles and particles with failed SiC but intact outer layer.
- Acquisition of pushout force data on graphite body upper fuel-closure plugs.
- Determination of partition coefficients of selected fission products by analysis of the encapsulated sorptivity specimens.
- Completion of a detailed study of standard and defective unbonded particles, including the measurement of gas release upon opening their encapsulation.
- Evaluation of the irradiation performance of both the PyC-coated and the PyC/SiC-coated B₄C particles.

- Completion of Core Conduction Cooldown Testing (CCCT) on five graphite bodies still housing fuel compacts.

4. QUALITY ASSURANCE

Experiment HRB-21 will be conducted in accordance with 10CFR50/B and ANSI/ASME NQA-1 requirements for quality assurance as specified in Appendix A of the Fuel/Fission Products Technology Development Plan,⁶ the ORNL QA manual, and document FQ-QAPI-HRB-19 et seq.⁷

5. CAPSULE DISASSEMBLY

5.1 TRANSFER FROM HFIR

5.1.1 Entire capsule cools in poolside facility for 1 to 3 weeks.

5.1.2 Raise the uppermost 0.6 m (2 ft) of capsule above pool level and detach the cable connector cover (part 1 in Fig. 5.1) by removing 14 socket-head 5-40 cap screws.

5.1.3 Detach the four gas line Swagelock fittings (part 2) with a 9/16-in. wrench as well as the Amphenol connector (part 3). Install caps on both ends of each gas line and caulk around these caps with a water-proof putty.

ORNL-DWG 90-2161

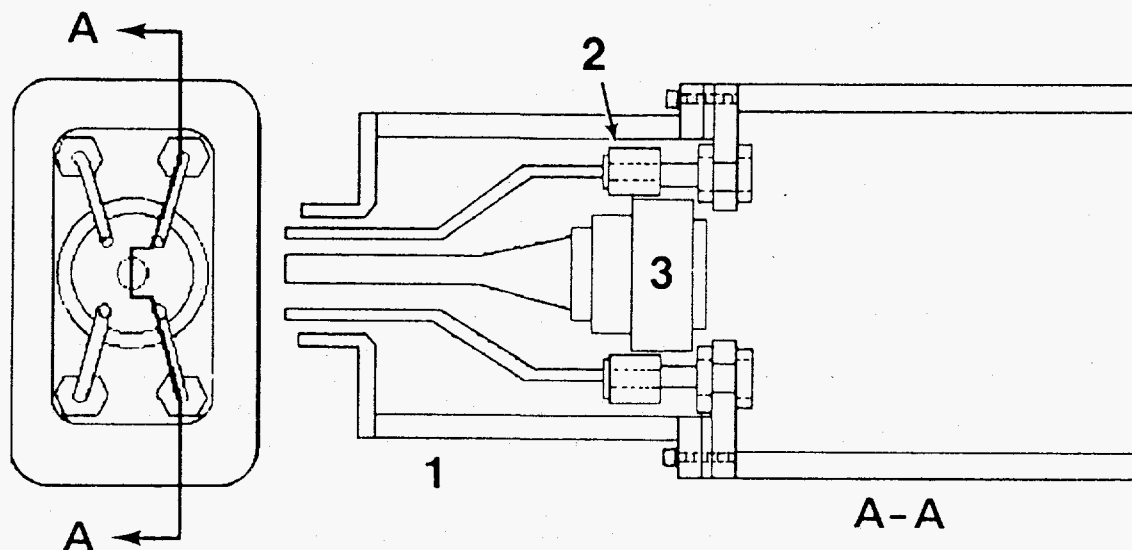

Fig. 5.1. Separation of capsule from umbilical cable. Identified components are: (1) gasketed cable connector cover, (2) gas line Swagelock fitting, and (3) instrumentation Amphenol connector.

5.1.4 Load the capsule into the 4.6 m (15-ft) top-loading "Monster" cask for transfer to HRLEL. Keep the top end of the capsule above water during insertion into the cask.

5.2 MAIN DISASSEMBLY AT HRLEL

5.2.1 The PIE test engineer or designated replacement is to be present during all operations and must approve any changes in these procedures.

5.2.2 Separate (by shear or saw) the lowermost 0.9 m (3 ft) of capsule. A marked copy of blueprint X3E12673-0210 showing the cut location will be provided.

5.2.3 Conduct gamma scan of capsule prior to dismantling to verify that no internal components are broken or out of position within the containment (see Sect. 6.1).

5.2.4 Remove capsule contents from containment tubes; keep horizontal throughout the following steps.

5.2.4.1 Using a lathe with carbide or diamond tool only, make a circumferential cut at the capsule top (location marked on Fig. 5.2) through both primary and secondary walls; do not use any water or oil coolant.

5.2.4.2 Pull out thermocouples and gas line tubes. Mount the capsule horizontally in a "V-channel" bed (a section of aluminum angle mounted on feet) with the severed upper end abutting a rigid stop (such as the sides of the jaws of a partially open vise, or a fixture provided). Visually examine the thermocouples and document (photograph) any unusual features.

5.2.4.3 Deburr edge of the upper circumferential cut by lathe-mounting the capsule and using turning tools to remove all material (or create an inside bevel) from the inner wall surface.

5.2.4.4 Make the indicated (Fig. 5.2) second circumferential cut at the capsule bottom through both containment tubes in the same manner as in 5.2.4.1.

5.2.4.5 Using a push rod with flat disk (supplied) to distribute the force on the lowest body (or the lower insulator if present), attempt to push out the upper insulator and graphite bodies into a second V-channel bed which is placed within a clean receiving tray; if successful go to step 5.2.5. The available pushing force is limited to about 110 N (25 lbf).

5.2.4.6 If any or all contents cannot be pushed out, remove any remaining portion of the lower insulator with tweezers. Mount and level the capsule on the bed of the milling machine and mill up to three longitudinal slits 3.2 mm (0.125 in.) wide fully through the secondary (outer)

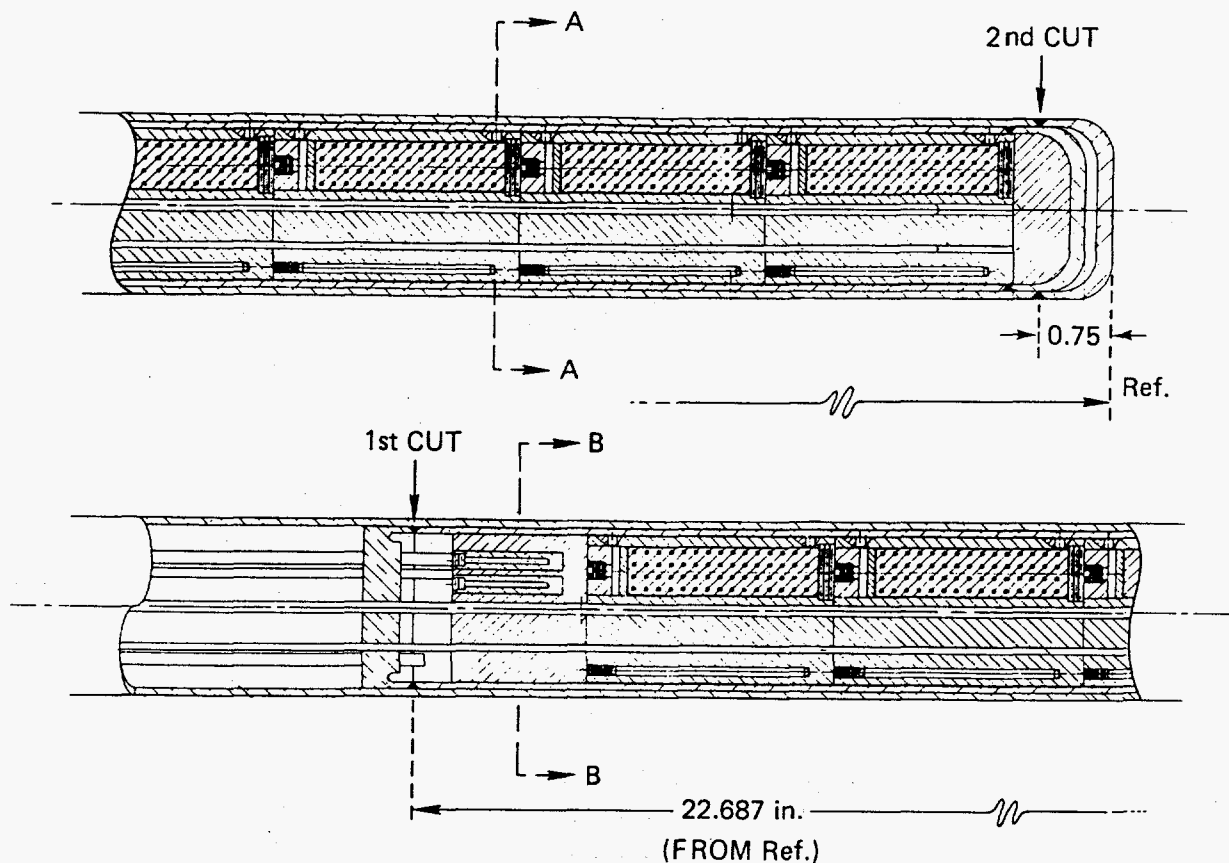

Fig. 5.2. Location for upper and lower circumferential cuts through containment (from blueprint X3E12673-0210).

containment tube, which has a wall thickness of 1.96 mm (0.077 in.). Orient the capsule (by looking into the open lower end) such that two of the slits fall at 120° from the control gas hole, while the third slit falls at 6.4 mm (0.25 in.) clockwise from the control gas hole (feature No. 1 in Fig. 5.3). After making one or two of these slits, try to slide this outer containment tube off the inner tube. The third slit, if required, will definitely expose the inner containment.

5.2.4.7 With the same setup and orientation as for the first slit of 5.2.4.6, mill an analogous slit fully through the primary (inner) containment tube, which has a wall thickness of 1.73 mm (0.068 in.), but with as little penetration as possible into the capsule contents. After making this initial slit, attempt step 5.2.4.5 again, because stress relief is likely to cause the containment tube to spring open slightly, freeing the contents.

5.2.4.8 If the initial slit is insufficient to release the capsule contents, repeat step 5.2.4.7 by making a second through slit at the other 120° -from-gas-hole location, permitting a one-third portion of the inner

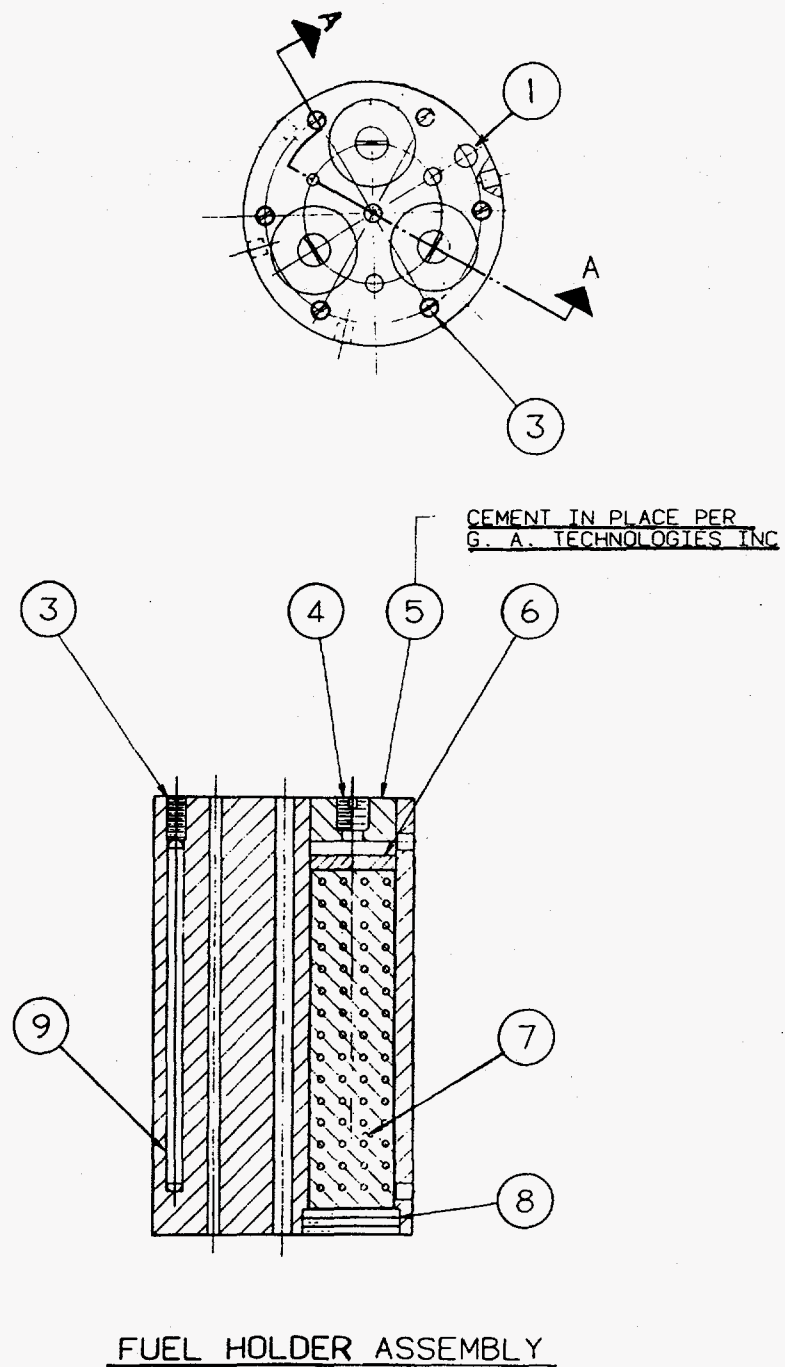

Fig. 5.3. Views of a graphite fuel body and its contents (from blueprint X3E12673-0214).

containment tube to be fully removed. Again attempt contents pushout, step 5.2.4.5.

5.2.4.9 If the graphite bodies are still stuck within the remaining two-thirds of containment, place the capsule in a supporting V-channel and repeat 5.2.4.7 with a third slit at the location 6.4 mm (0.25 in.) clockwise from the gas hole. Remove containment shell segments and then capsule contents.

5.2.5 Visually examine and photograph all graphite bodies and insulators, noting any unusual areas (see Sect. 6.2 for details).

5.2.6 Place each graphite fuel body in a suitable, properly identified individual container pending further disassembly and PIE.

5.2.7 Remove dosimetry packets and encapsulated specimens (shown as part No. 9 in Fig. 5.3) from all graphite bodies by carefully unscrewing the small graphite screw plugs (part No. 3); screw plug slots are probably very fragile.

5.2.7.1 Any screw plugs that stick will be bored out: 3.2 mm diam by 6.4 mm deep (0.125 by 0.25 in.).

5.2.7.2 Remove any contents that stick by drilling a 2.6-mm-diam (0.101-in.) corresponding hole from the bottom end of the graphite body through to the bottom of the specimen and then pushing through the top hole with a smaller diameter drill bit. A special jig that indexes with the gas line hole will be provided to guide the hole drilling.

5.2.8 Remove flux monitor tubes (total of 2) and encapsulated specimen graphite tubes (6) from the upper insulator (see Fig. 5.4). Some or all of the graphite tubes may be extractable from the top with tweezers. Remove any remaining graphite tubes, as well as the two flux monitor tubes, by drilling a 1.6-mm-diam (0.062 in.) corresponding hole from the bottom end of the insulator through to the bottom of the tube and then pushing through these new access holes with a smaller diameter drill bit. A special jig that indexes with the control gas hole will be provided.

5.2.9 Remove fuel compacts from the specified bodies, tentatively Nos. 5, 6, and 8, by removing (refer to Fig. 5.3) the large bottom end caps (part No. 8), the corresponding small top screw plugs [No. 4; bore these out if they stick: 5.1 mm diam by 4.8 mm deep (0.20 by 0.19 in.)], and pushing the compacts (No. 7) out (if necessary) with a rod through the resulting top holes against the built-in push disks (No. 6).

5.2.10 Place each removed component in a marked container.

5.2.10.1 Special numbered vials exist for the dosimetry packets. These must be promptly shipped to L. R. Greenwood at Argonne National Laboratory (ANL) for fluence determination by gamma counting. Their receipt is requested within one month of end of irradiation.

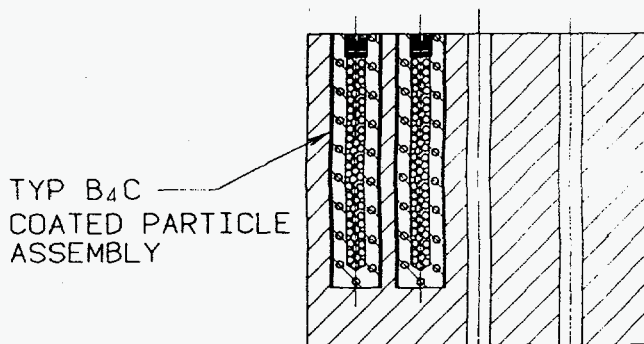
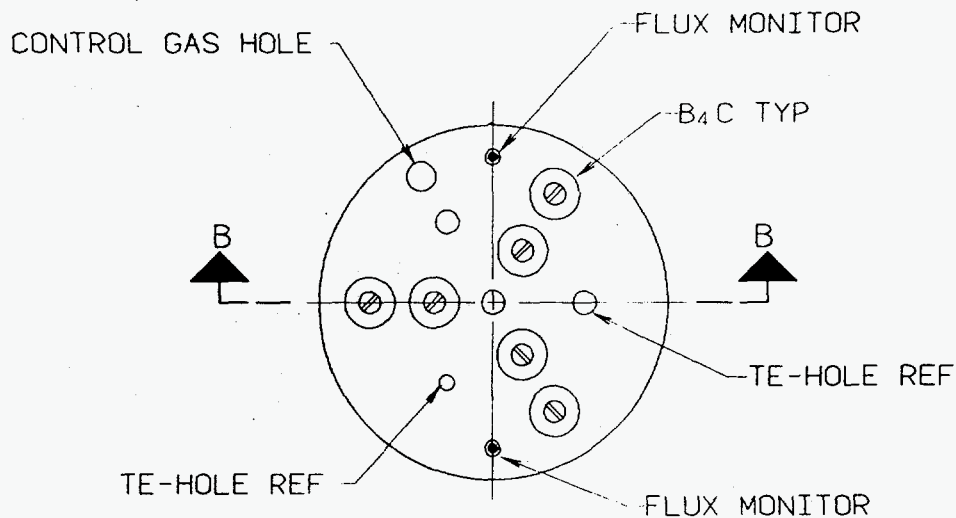

SECTION B-B TOP VIEW @ UPPER INSULATOR

Fig. 5.4. Views of upper insulator and coated B_4C specimens in their graphite tube containers (from blueprint X3E12673-0216).

5.2.11 The specimens encapsulated in sealed 2.2-mm-diam niobium tubes will be opened by laser perforation by means analogous to those described previously.⁸ These specimens include the unbonded particles, both standard and defective, and the sorptivity materials. Gamma spectrometry will be made on these intact capsules before opening and on all the capsule components as well as any gases collected and measured after opening. All contents will be stored in suitable, properly identified containers.

5.2.12 Unload the coated B₄C specimens, housed in graphite tubes with graphite setscrew caps (located in the upper insulator, Fig. 5.4) by unscrewing the caps or boring them out — 6.4 mm diam by 5.1 mm deep (0.25 by 0.20 in.).

5.2.13 Measure the bonding strength of the upper fuel closure plugs (part No. 5 in Fig. 5.3) in the graphite bodies (cemented in place at time of fabrication) by a pushout test using a force gage. The expected force range is 22 to 445 N (5 to 100 lbf). Record each measured pushout force and the hole and body identification in the PIE notebook (see Sect. 9).

6. POSTIRRADIATION EXAMINATION

The techniques and procedures to be used in the PIE of the fuel samples and encapsulated samples of capsule HRB-21 are described in this section. Not all tests or examinations will be performed on every sample. Table 6.1 shows the plan of PIE tests to be performed on the fuel compacts and Table 6.2 provides details on the planned postirradiation heating

Table 6.1. Tentative PIE test matrix for eight fuel bodies

Compact	Dimension measurement	Ceramography, microscopy	Total failure	IMGA	Encapsulated samples	CCCT	Post-CCCT exam
9	X				X	X	X
2	X				X	X	X
3	X				X	X	X
4	X				X	X	X
5	X	X	X	X	X		
6	X	X	X	X	X		
7	X				X	X	X
8	X	X	X	X	X		

Table 6.2. Tentative CCT matrix for HRB-21 samples

Test No.	Body No.	Heating temperature (°C)	Average % FIMA		Number of particles	
			Fissile	Fertile	Fissile	Fertile
1	9	1600	15.5	0.7	6,700	13,310
2	2	1400	20.2	1.5	5,540	13,310
3	7	1800	20.2	1.5	5,540	13,310
4	3	1600	23.0	2.3	4,070	13,310
5	4	1600	24.4	2.7	3,380	13,310
Total					25,230	66,550

tests in the CCCTF. The PIE tests to be done on the various samples are tentative in that unforeseen conditions encountered during disassembly and visual examination may preclude further analysis on some samples or cause substitution of others for testing. Such decisions will be made by the principal investigator. Further details on each of the various planned PIE techniques are given below.

6.1 GAMMA SCAN

Perform gamma scans at 0° and 90° orientations along the length of the capsule using a multichannel gamma analyzer in the energy range 0.55 to 0.75 MeV prior to disassembly of the capsule contents from the metal containment housing. This procedure is to confirm the integrity and proper positioning of all fuel compacts before disassembly begins. Repeat the procedure with the individual graphite bodies after their removal from the capsule.

6.2 VISUAL EXAMINATION

The complete capsule and all its contents will be given detailed visual examination as the disassembly proceeds. The fuel compacts will be examined for evidence of cracking or debonding and for the presence of failed particles at the compact surface. All contents (compacts, graphite bodies, encapsulated specimens) will be examined for overall integrity and signs of cracking or other damage. Macrophotos of each fuel compact and graphite body will be taken (ends and 0° and 180° side views) upon unloading. The unbonded coated fuel particles will be subjected to close visual examination to assess mechanical failure of the OPyC and SiC coatings. Their postirradiation condition, as well as that of the sorptivity specimens and coated B₄C particles, will be noted and photographed.

6.3 CAPSULE COMPONENT AND FUEL COMPACT DIMENSIONS

The outside diameter and the length of each fuel compact and graphite body will be measured to the nearest 0.01 mm (0.0005 in.) using the irradiated component dimensional measurement (ICDM) facility which employs a laser micrometer for precise, noncontact measurements. The diametral data will be obtained at three or more spaced locations along the length of each sample and at three or more rotational orientations (about the axis of symmetry) between 0 and 90°. Measurements will also be made of the inside diameters of the fuel-compact-containing holes in the graphite bodies. Weight determinations to 0.001 g precision will also be made on a selected number of the fuel compacts removed from the graphite bodies.

6.4 IRRADIATED MICROSPHERE GAMMA ANALYZER

The automated IMGA apparatus allows the measurement of fission product inventories of large numbers of individual fuel particles. The

activities of selected volatile fission products are ratioed to those of chemically stable, immobile isotopes (e.g., ^{137}Cs to ^{106}Ru) and compared with theoretically generated ratios to determine the degree of fission product retention of the particles. Particles which appear intact externally but which have failed or defective internal containment (SiC layer) can be detected by this technique. Unbonded particles from fuel compacts (after deconsolidation) and encapsulated unbonded particles will be IMGA subjects. The electrochemical deconsolidation of fuel compacts will be carried out in a way similar to that described in ref. 9.

6.5 CERAMOGRAPHY

Ceramographic mounts of selected compacts and particle specimens, including the coated B_4C particles, will be prepared and examined. Microstructural changes within the kernels and coatings can be evaluated with this technique.

6.6 ELECTRON MICROPROBE

The JEOL JXA-840A SEM/Electron Probe Microanalyzer will be directed toward determining fission product distributions within the fuel kernel and interaction with the coatings. Specimens will be the sectioned and mounted individual particles from the ceramographic analysis above. Both wavelength dispersive (WDS) and energy dispersive (EDS) X-ray spectrometers are available for elemental identification.

6.7 SORPTIVITY EXPERIMENT

The analysis of the sorptivity experiment components will be carried out using high-resolution gamma spectrometry to determine activation product inventories for the different specimen materials. These materials include both untreated and oxidized (equivalent to 1 wt % burnoff) graphite, conventional and SiC-exposed inert coated particles, and doped cylinders of compact-matrix material. The dopants were known amounts of stable isotopes of cesium, silver, strontium, and iodine. The object of the experiment is to measure the distribution of these simulated fission products among the above material types. This experiment is unique and detailed procedures for its analysis will be determined and specified prior to opening its encapsulation.

6.8 CORE CONDUCTION COOLDOWN TEST FACILITY

The CCCTF will be used to provide postirradiation heating in a controlled atmosphere which allows measurement of fuel failure and fission-product release at sustained high temperatures. Since the methods validation program for normal operating conditions examines in-reactor performance at temperatures up to 1250°C , these tests will emphasize the temperature range of 1400 to 1800°C where data are lacking. The final

choice of samples for specific CCCT runs is dependent upon actual HRB-21 irradiation conditions and fuel performance results. The tentative test matrix for HRB-21 samples was given in Table 6.2. The heating times are expected to be 1000 h for tests at temperatures $\leq 1600^{\circ}\text{C}$ and ≤ 500 h for tests $> 1600^{\circ}\text{C}$. Actual test times will be determined jointly by the test engineer in consultation with the data analyst based on the observed fission product release in each test, the furnace capabilities, and the data needs for model validation purposes. After test exposure, the fuel compacts will be deconsolidated for analysis of individual particles by the techniques covered in Sects. 6.4 through 6.6.

7. THERMAL ANALYSIS

A postirradiation thermal analysis of the capsule will be performed and the results summarized in the final report. The PIE will supply post-irradiation fuel compact and graphite body dimensional data as input for this analysis. The analysis will include:

- helium/neon flow rate history for the capsule;
- thermocouple histories for all thermocouples throughout the irradiation;
- graphite body temperatures as functions of time and position;
- fission rates as function of time and position;
- fuel compact linear heating rate as function of time (including individual fissile, fertile, gamma, and total heating rates);
- plots for each fuel compact of the surface and centerline temperature histories plus the time-average centerline temperature for each compact; and
- assessment of each encapsulated specimen minimum, mean, and maximum temperatures during irradiation.

8. STORAGE OF CAPSULE CONTENTS

All the fuel compacts and other contents of capsule HRB-21, together with the primary and secondary containment tubes, will be placed in suitable numbered hot cell containers as the disassembly proceeds. The identification and contents of each container will be recorded in a hot cell logbook and in the test engineer's laboratory notebook.

9. DOCUMENTATION

Observations, photographs, and other data will be recorded in ORNL laboratory notebooks as the examination proceeds. Moreover, a copy of this PIE procedure will be kept as a working, marked-up copy and any changes to this plan will be recorded and dated as they occur during PIE. Progress of the PIE effort will be described in ORNL HTGR Technology Program monthly progress reports. The final results of PIE examination after irradiation and postirradiation heating experiments (CCCTs) will be documented in an ORNL topical report.

10. TENTATIVE WORK SCHEDULE FOR HRB-21 PIE

The capsule is scheduled (contingent upon HFIR restart) to complete irradiation in HFIR in mid-1990. The capsule will be transferred from HFIR to HRLEL as soon as reasonably practical following the irradiation. Disassembly is slated to commence one month after end of irradiation and be complete 3 months thereafter. All PIE work is expected to be completed within 18 months of the end of irradiation, the conduction cooldown testing three months thereafter, and the final ORNL topical report at 26 months from irradiation termination.

11. REFERENCES

1. M. J. Kania and K. Fukuda, *Experimental Test Plan: USDOE/JAERI Collaborative Program for the Coated Particle Fuel Performance Test*, DOE-HTGR-87090 (ORNL-TM-11346), December 1989.
2. I. M. Tang, *HRB-21 Test Specification*, DOE-HTGR-88331, September 1989.
3. N. H. Packan, M. J. Kania, K. R. Thoms and E. D. Clemmer, *Operating Plan for Capsule HRB-21 Irradiation*, DOE-HTGR-88370 (ORNL/TM-11403), December 1989.
4. D. T. Goodin, M. J. Kania, and B. W. Patton, *Experimental Plan for Irradiation Experiment HRB-21*, DOE-HTGR-87091 (ORNL/TM-10987), April 1989.
5. W. J. Scheffel, D. T. Goodin, and I. M. Tang, *Capsule HRB-21 Preirradiation Report*, General Atomics document DOE-HTGR-88357, September 1989.
6. Project Staff, *Modular HTGR Plant Fuel/Fission Product Technology Development Plan*, Rev. 1, DOE-HTGR-86027, April 1987.

7. N. H. Packan, Quality Assurance Program Index (QAPI) for HFIR Irradiation Experiments HRB-19, et seq., FQ-QAPI (in preparation).

8. B. F. Myers, *Fission Product Transport in Reactor Experiments*, DOE-HTGR-85115, September 1985, pp. 58-76.

9. T. N. Tiegs, E. L. Ryan, and M. J. Kania, *HTGR Fuel Rod Deconsolidation*, ORNL/TM-6426, December 1978.

Capsule	32	16	8	4	2	1	Ref.	Capsule	32	16	8	4	2	1	Ref.
1						^a		26							
2								27							
3								28							
4								29							
5								30							
6								31							
7								32							
8								33							
9								34							
10								35							
11								36							
12								37							
13								38							
14								39							
15								40							
16								41							
17								42							
18								43							
19								44							
20								45							
21								46							
22								47							
23								48							
24								49							
25															

^aThe actual spacing of the reference marks, proceeding from right to left, is: 0.3 mm (0.012 in.) for the reference pair, a 1.9 mm (0.075 in.) gap, and 0.6 mm (0.025 in.) between adjacent columns of data marks.

Identification code for dosimetry packets (L. R. Greenwood)

APPENDIX

19/20