

LA-UR- 97 - 1665

CONF-970503--5

Approved for public release;
distribution is unlimited.

Title:

THE RF SYSTEM FOR THE NATIONAL
SPALLATION NEUTRON SOURCE LINAC

Author(s):

P. J. Tallerico
J. Billen
A. Jason
M. T. Lynch
T. Wangler
L. Young

Submitted to:

PAC '97 Conference
Vancouver, Canada
May 12-16, 1997

DISCLAIMER

This report was prepared as an account of work sponsored by an agency of the United States Government. Neither the United States Government nor any agency thereof, nor any of their employees, makes any warranty, express or implied, or assumes any legal liability or responsibility for the accuracy, completeness, or usefulness of any information, apparatus, product, or process disclosed, or represents that its use would not infringe privately owned rights. Reference herein to any specific commercial product, process, or service by trade name, trademark, manufacturer, or otherwise does not necessarily constitute or imply its endorsement, recommendation, or favoring by the United States Government or any agency thereof. The views and opinions of authors expressed herein do not necessarily state or reflect those of the United States Government or any agency thereof.

DISTRIBUTION OF THIS DOCUMENT IS UNLIMITED ^{HH}

MASTER

Los Alamos
NATIONAL LABORATORY

Los Alamos National Laboratory, an affirmative action/equal opportunity employer, is operated by the University of California for the U.S. Department of Energy under contract W-7405-ENG-36. By acceptance of this article, the publisher recognizes that the U.S. Government retains a nonexclusive, royalty-free license to publish or reproduce the published form of this contribution, or to allow others to do so, for U.S. Government purposes. Los Alamos National Laboratory requests that the publisher identify this article as work performed under the auspices of the U.S. Department of Energy. The Los Alamos National Laboratory strongly supports

DISCLAIMER

Portions of this document may be illegible in electronic image products. Images are produced from the best available original document.

The RF System for the National Spallation Neutron Source Linac¹

Paul Tallerico, James Billen, Andrew Jason, Michael Lynch,
Thomas Wangler, Lloyd Young, Los Alamos National Laboratory, P.O. Box 1663,
MS H-817, Los Alamos, NM 87545

Abstract

The National Spallation Neutron Source (NSNS) system has been proposed to dramatically improve the neutron capabilities for science applications in the US. The NSNS is a fast pulse neutron source that would consist of a 1000 MeV H⁻ linac, an accumulator ring, a neutron target, and an experimental area. Although the NSNS is to be built at Oak Ridge, the design responsibility is delegated to five US national laboratories, and the Los Alamos National Laboratory is responsible for the linac portion of this machine, from the output of the radio frequency quadrupole (RFQ) accelerator, to the entrance to the accumulator ring. In the baseline design, a total of 59 klystrons are used to provide the RF power for a 1-MW average power beam in the accumulator ring, and a 1.04 ms pulse length, 6.24% duty factor beam in the linac. The frequencies chosen are 402.5 MHz for the RFQ and drift tube linac (DTL) portions of the machine, and 805 MHz for the coupled-cavity DTL (CCDTL) and coupled cavity (CCL) portions of the linac. The baseline 805 MHz klystron is capable of 2.5 MW peak power into a flat load, and it contains a modulating anode. The backup 805 MHz klystron is cathode pulsed, and has a 5 MW peak output power. The modulators for these two klystrons are vastly different. The challenges and compromises for the two klystrons and their associated modulators and RF systems are discussed. The baseline design RF system is presented in detail.

Introduction

The klystron is used in most high power, high energy proton accelerators, and so it was the logical choice as the RF generator for the NSNS project, which requires over 104 MW of peak power for 1.04 ms H⁻ pulses at a beam duty factor of 6.24%. We must add at least 70 μ s to fill the standing-wave accelerator structures and to lock the control loops for the fields in the accelerator. Thus the RF power is applied for about 1.1 ms, and the RF duty factor is 6.6%.

A schematic drawing of the 1 MW accelerator[1] is shown in Fig. 1, along with a schematic of the 4 MW upgrade.

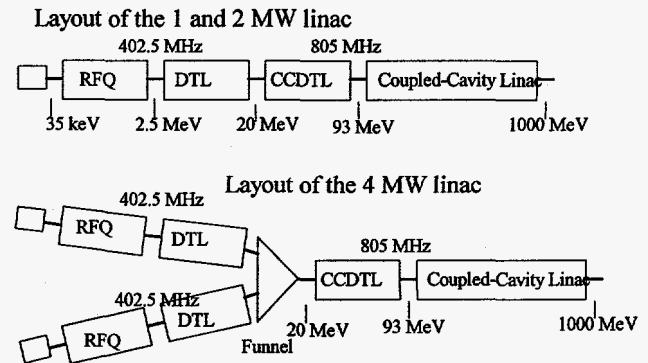

Figure 1. Layout of the accelerator structures for the 1, 2, and 4 MW NSNS linacs.

The power applied to the klystron has 100 μ s rise and fall times. Thus, the pulse of power through the klystron will be about 1.25 ms long, and the klystrons will have a 7.5% video duty factor. This accelerator is to be comprised of an RFQ and DTL, operating at a low frequency, and then a CCDTL and CCL at an integer multiple of the base frequency. NSNS is to be upgradeable, to both 2 MW and 4 MW of beam power, with a funnel and two parallel 402.5 MHz front ends for the final upgrade to 4 MW. The frequencies chosen are 402.5 MHz for the RFQ and DTL portions of the accelerator, up to 20 MeV. From 20 to 93 MeV, the accelerator is a CCDTL, and from 93 to 1000 MeV, the linac is a CCL. Both the CCDTL and CCL operate at 805 MHz. The amplifier size was chosen as 2.5 MW, the maximum power for a long-pulse klystrons with a modulation anode[2], to minimize the cost and maximize the reliability of the RF system. Two klystrons will be placed in each modulator, and Fig. 2 is a schematic diagram of a dual-klystron-modulator RF system at 805 MHz. The schematic diagram for the 402.5 MHz system is identical, except that only two modulators and 4 klystrons are used for the 1 and 2 MW linacs.

¹ This research is sponsored by the Division of Materials Sciences, DOE, under contract DE-AC05-OR22464 with Lockheed Martin Energy Research Corp.

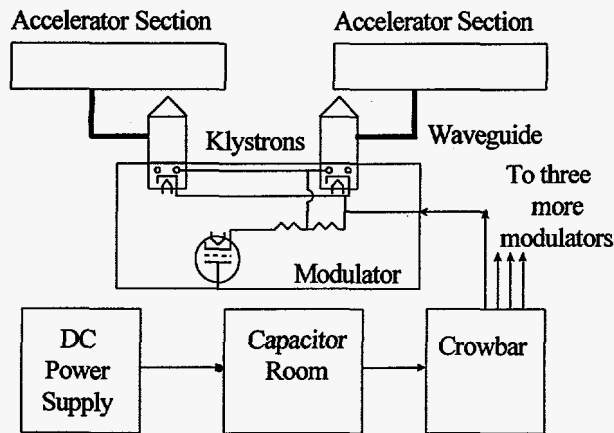

Figure 2. Schematic of the RF system with the dual-klystron modulator.

Although Fig. 2 is just a schematic, notice that only one switch tube is used. This reduces the capital cost, and increases the reliability of the modulator, at the expense of a somewhat longer fall time of the cathode current pulse, and therefore yields a slightly higher operating cost.

Technology Choices

We have chosen the high main frequency of 805 MHz for this project to keep the sizes of the accelerator structures as small as possible, consistent with enough stored energy in the RF structure. The large CW linacs being proposed for tritium production use 700 MHz for their high frequency[3], and the Japanese waste-transmutation prototype accelerator is proposing[4] 600 MHz for the high frequency part of that accelerator. Both machines are proton linacs. Klystron vendors indicated that many technical solutions are possible for the NSNS project, including the conventional klystron, the multiple beam klystron (MBK), and higher-order mode inductive output tube (HOM-IOT). Only the conventional klystron has been used in accelerator work to date, so it was chosen as the baseline RF amplifier. Even with the conventional klystron, the vendors were not in agreement about the most economical and maintainable solution for this project. The frequencies of the linac were chosen at 402.5 and 805 MHz, although it is expected that the minimum cost is almost independent of frequency over several hundred MHz[5]. The frequency of 805 MHz has been used for several pulsed proton linacs, which have used very long-lived klystrons. The LANSCE klystrons, at 1 ms, 120 Hz, and 1.25 MW have a life of over 80,000 hours, and the FermiLab 100 μ s, 10 Hz, 12 MW klystrons also appear to have an excellent life of over 30,000 hours. For klystrons with a modulating anode, the opinion is that a 2.5 MW output power should result in a good rf system design. The cathode pulsed klystron,

without a modulation anode, could be made to much higher power, and 5 MW was chosen as a reasonable limit for this project[2]. Higher peak powers at this pulse length may be possible, but the klystron would require development, and this means risk to the program. With the lower power klystron, it is entirely feasible to put two klystrons into one modulator, but it is much more difficult to do this with the 5 MW, cathode-pulsed klystron. A schematic diagram of a dual 2.5 MW klystron rf system was shown in Fig. 2, and the corresponding diagram for a single 5 MW klystron is shown in Fig. 3. Both systems can drive the same two accelerator modules. The main switching element in the 5 MW modulator is a solid state assembly made of a series connection of insulated-gate bipolar transistors (IGBT's), and only the crowbar is a classic electron tube.

Another advantage of Fig. 3 is that all the electronics, except the pulse transformer and klystron socket, are in air-insulated enclosures, so the amount of insulating oil is greatly reduced compared to the circuit in Fig. 2. This has fire safety, cost, and maintenance advantages. The capacitor bank in Fig. 3 stores only about 25% of the energy per peak MW of output power, compared to the energy stored per MW in the Fig. 2 circuit. The lower stored energy would cause much more distortion in the output pulse of the modulator, but the bouncer circuit, which contains another capacitor and inductor, is triggered so that its voltage changes during the pulse, to compensate for the capacitor drop.

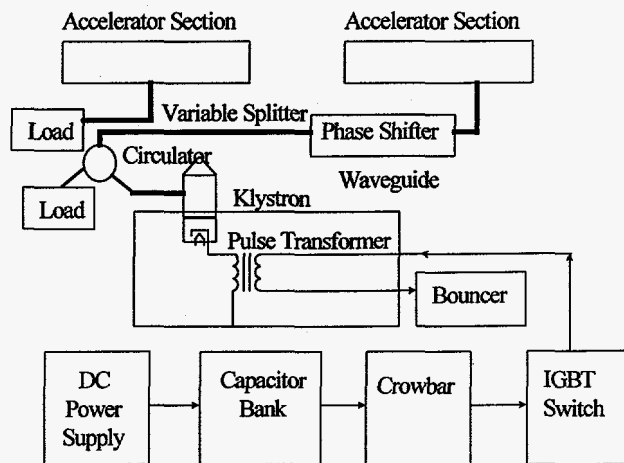

Figure 3. The solid-state modulator with a 5 MW klystron and waveguide splitter system.

The 5 MW-klystron system has the potential to reduce costs, since the 5 MW klystron is much less expensive than two 2.5 MW klystrons. However, the 2.5 MW klystron would operate at a much lower beam voltage of

about 110 kV for a 60% efficiency. This klystron voltage is in the optimum range for a modulation anode floating deck modulator. The 5 MW klystron would operate at 155 kV for the same perveance and efficiency, and this voltage makes it very difficult to make a floating-deck modulator. The fields inside the electron guns for the two klystrons are also different, with the higher fields in the higher power klystron. The higher power klystron therefore requires a series-type or transformer-type modulator, in which the switch transmits the entire pulse power. In the floating-deck modulator (in Fig. 2), the switch only has to transmit a fraction of the pulse power, since only the capacity of the modulation anode is being charged and discharged. With the 5 MW klystron, the reflected power levels are at a damaging level due to the higher forward power, so the system requires a circulator. The single klystron would drive two accelerator modules, and we feel that since the beam loading will be different in each module, we will also require a high-powered variable-ratio power splitter and phase shifter with the 5 MW klystron. With this type of modulator, a single power supply is used for each klystron, and this raises the capital costs.

A cost study has given the preliminary results that a 10% savings in the RF system are possible with the 5 MW klystron, but the modulator is so large that it must be repaired in situ, which reduces the availability of the RF system.

System Details

The baseline system has 56 2.5 MW peak, 805 MHz klystrons and 3 active plus one spare 1.25 MW peak, 402.5 MHz klystrons for the 1 MW beam. The system is easily upgradeable by adding more modulators and power supplies for both 2 and 4 MW beams. In the latter case, there are 6 402.5 MHz and 84 805 MHz klystrons required. The pulsed power system is a major cost of a pulsed RF system, so two klystrons are placed in each modulator. Thus, the baseline 1 MW system has 4 402.5 MHz modulators and 28 805 MHz modulators. All the klystrons have modulation anodes, and the modulators are the floating deck type, in which only the potential of the modulation anode varies to pulse the RF system. Figure 2 shows a schematic diagram of this type of modulator, with the two klystrons installed. This modulator is small and simple, but heavy and oil-filled.

Whenever the klystrons or modulator needs repair, the entire unit is removed by fork lift and replaced. The repair is then done off line. The power supplies for the klystrons also can be expensive, and to minimize this cost, eight klystrons are to be driven by a single power supply, capacitor bank, and crowbar for the 805 MHz RF system, and a single supply and capacitor bank is to be used for the 402.5 MHz system. The 805 MHz klystrons will have a saturated efficiency of 60%, and operate at 110 kV.

Since the system is pulsed, the control margin allowance is 20% of the RF power, so each klystron will deliver a maximum of 2.0 MW to the accelerator module. Methods of using adaptive feed forward techniques to reduce this margin are being studied.

Future Work

The baseline RF system and the system with the 5 MW klystrons will both be designed in more detail so that more accurate cost and reliability data can be assembled. Early next year, the 805 MHz development effort will begin on the baseline 2.5 MW klystrons and their modulators. If funding permits, and good progress is made on the advanced generators by other accelerator projects, a development contract for an advanced RF generator (such as the multiple beam klystron) will be placed.

References

- [1] A. Jason, T. Bhatia, J. Billen, D. Schrage, S. Kurennoy, F. Krawczyk, M. Lynch, S. Nath, R. Shafer, H. Takeda, P. Tallerico, T. Wangler, R. Wood, L. P. Grand, R. McKenzie-Wilson, "A High Intensity Linac for the National Spallation Neutron Source", These Proceedings.
- [2] G. Faillon and C. Bearzatto, "Very long pulse high power klystrons for FEL and their generating conditions", *International Journal of Electronics*, vol. 65, pp. 579-588, March 1988.
- [3] G.P. Lawrence, "Transmutation and Energy Production with High Power Accelerators", *Proceedings of the 1995 Particle Accelerator Conference*, pp. 35-39, Dallas, 1995.
- [4] H. Mizumoto, et al., "High Intensity Proton Accelerator Nuclear Waste Transmutation", *Proceedings of the 1992 Linear Accelerator Conference*, Ottawa, pp. 749-751, 1992.
- [5] G.P. Lawrence, "Los Alamos High-Power Proton Linac Designs", *International Conference of Accelerator-Driven Transmutation Technologies and Applications*, Las Vegas, Nevada, pp. 177-186, 1994.