

CONF-970607--7

COMSORS: A LIGHT WATER REACTOR CHEMICAL CORE CATCHER

C. W. Forsberg, G. W. Parker, J. C. Rudolph, and I. W. Osborne-Lee

Chemical Technology Division
Oak Ridge National Laboratory*
P. O. Box 2008
Oak Ridge, Tennessee 37831-6180
Tel: (423) 574-6783
Fax: (423) 574-9512
Email: forsbergcw@ornl.gov

M. A. Kenton

Creare Inc.
P.O. Box 71
Hanover, New Hampshire 03755

RECEIVED

MAR 06 1997

OSTI

February 24, 1997

MASTER

Prepared for Presentation at

2nd International Topical Meeting on Advanced Reactor Safety
American Nuclear Society
Orlando, Florida
June 1-4, 1997

*The submitted manuscript has been
authored by a contractor of the U.S.
Government under contract No. DE-
AC05-96OR22464. Accordingly, the U.S.
Government retains a nonexclusive,
royalty free license to publish or
reproduce the published form of this
contribution, or allow others to do so, for
U.S. Government purposes.*

*Managed by Lockheed Martin Energy Research Corp., under contract DE-AC05-96OR22464 for the
U.S. Department of Energy.

DISTRIBUTION OF THIS DOCUMENT IS UNLIMITED

lh

DISCLAIMER

This report was prepared as an account of work sponsored by an agency of the United States Government. Neither the United States Government nor any agency thereof, nor any of their employees, make any warranty, express or implied, or assumes any legal liability or responsibility for the accuracy, completeness, or usefulness of any information, apparatus, product, or process disclosed, or represents that its use would not infringe privately owned rights. Reference herein to any specific commercial product, process, or service by trade name, trademark, manufacturer, or otherwise does not necessarily constitute or imply its endorsement, recommendation, or favoring by the United States Government or any agency thereof. The views and opinions of authors expressed herein do not necessarily state or reflect those of the United States Government or any agency thereof.

DISCLAIMER

Portions of this document may be illegible in electronic image products. Images are produced from the best available original document.

COMSORS: A LIGHT WATER REACTOR CHEMICAL CORE CATCHER

Charles W. Forsberg
Oak Ridge National Laboratory
P.O. Box 2008
Oak Ridge, TN 37831-6180
(423) 574-6783

George W. Parker
Oak Ridge National Laboratory
P. Box 2008
Oak Ridge, TN 37831-6223
(423) 574-6858

Jeff C. Rudolph
Oak Ridge National Laboratory
P.O. Box 2008
Oak Ridge, TN 37831-6221
(423) 574-6882

Irvin W. Osborne-Lee
Oak Ridge National Laboratory
P.O. Box 2008
Oak Ridge, TN 37831-6133
(423) 574-1144

Mark A. Kenton
Creare Inc.
P.O. Box 71
Hanover, NH 03755
(603) 643-3800

ABSTRACT

The Core-Melt Source Reduction System (COMSORS) is a new approach to terminate light-water reactor (LWR) core-melt accidents and ensure containment integrity. A special dissolution glass made of lead oxide (PbO) and boron oxide (B₂O₃) is placed under the reactor vessel. If molten core debris is released onto the glass, the following sequence happens: (1) the glass absorbs decay heat as its temperature increases and the glass softens; (2) the core debris dissolves into the molten glass; (3) molten glass convective currents create a homogeneous high-level waste (HLW) glass; (4) the molten glass spreads into a wider pool, distributing the heat for removal by radiation to the reactor cavity above or transfer to water on top of the molten glass; and (5) the glass solidifies as increased surface cooling area and decreasing radioactive decay heat generation allows heat removal to exceed heat generation.

I. INTRODUCTION

To ensure the integrity of the containment building and prevent the release of radionuclides to the environment in the event of a core-melt accident that breaches the reactor vessel, core debris must be cooled after it leaves the reactor vessel. Core debris can threaten containment integrity in two ways:

Excess temperature. The core debris (>2000° C) can (1) "ablate" a hole through the containment basemat or side walls and/or (2) dehydrate and weaken the concrete. The problem is inefficient heat-transfer mechanisms to dump the heat. This

lack of good heat transfer results in very-high core-debris temperatures which can destroy concrete. There are two reasons for poor heat transfer.

Geometry. In some accident scenarios, the core debris may pile up in a particular location and create very-high local temperatures.

Composition. The core debris primarily consists of high-temperature ceramic materials which act as insulators. Because of insufficient heat transfer within the debris, the bottoms of core debris piles may burn holes through the concrete even if the top of the core debris is cold and under water.

Overpressurization. Chemical and thermal reactions between the core debris and the concrete can generate condensable and noncondensable gases that may overpressurize the containment and thus cause the containment to fail. Furthermore, these gases, in turn, can react with zirconium in the core-melt debris to create potentially noncondensable and combustible gases by metals reactions such as:

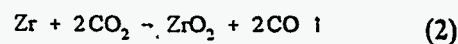
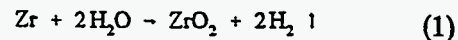

II. DESCRIPTION OF COMSORS

The basic concept^{1,2} of COMSORS is to place glass or glass formers under the reactor vessel (Fig. 1). In a core melt accident, the core debris exits the reactor vessel, melts the glass, and dissolves into the glass melt. Core debris of unknown composition and geometry, that may be uncoolable, is converted into a relatively uniform glass composition with known properties in a coolable geometry. COMSORS is a chemical core catcher in which the glass composition is used to adjust the physical and chemical properties of the core debris to properties that are favorable for termination of a core-melt accident.

To develop COMSORS, an initial core-melt accident scenario was chosen to facilitate analysis. For this purpose, a representative core-melt scenario of the proposed Simplified Boiling-Water Reactor (SBWR) was chosen (Table 1). Representative design parameters for COMSORS are also shown.

III. OPERATION OF COMSORS

During an accident, the COMSORS evolves through three stages (Fig. 2).

A. Stage 1: Initial Dissolution of Core Debris in Glass

In the first stage of the COMSORS response, the molten core material drops onto the glass floor (there is a steel work surface over the glass). The following sequence of events happen:

1. Short-term and long-term heat removal. Glass absorbs heat from core debris for hours as the glass heats up and becomes a flowable liquid. For ultimate heat removal, cooling water is supplied from the suppression pool positioned above COMSORS. The water is released onto the core debris and glass via pipes with fusible plugs that melt at high temperatures. (This is the same technique used by sprinkler systems in commercial buildings.) Boiling of water removes the heat from the top surface of the molten glass. In the longer term, water from steam that has condensed in the containment above will flow down onto COMSORS. Under adiabatic conditions, it takes many hours to melt the glass. If the cooling water is on top of COMSORS early in the accident sequence, days may be required to melt the glass and dissolve the debris into the glass.

Table 1. SBWR design parameters and COMSORS design parameters

Reactor design parameters

Type: SBWR

Reactor power level: 2000 MW(t)

Reactor cavity floor diameter: 7.6 m

Reactor cavity floor area per reactor power rating: 0.02 m²/MW

COMSORS design parameters

Glass volume: 105 m³

Glass mass: 810 t

Initial glass molar composition: 3 PbO:1B₂O₃

Initial glass density: 7.7 g/cm³

Reference chemical compositions before and after interaction with core debris (kg)

Compound	Before	After
Glass		
PbO	733,000	586,500
B ₂ O ₃	77,000	77,000
Pb		136,000
Core debris		
UO ₂	81,000	
U ₃ O ₈		84,200
Zr	10,000	
ZrO ₂	30,000	43,500
Fe	10,000	
Fe ₃ O ₄		13,800

Postaccident "equilibrium" calculated conditions after debris dissolution in glass (Stage 2)

Water over core debris

Bulk glass temperature: 547°C

Downward heat flux: 0.4 kW/m²

Upward heat flux: 130 kW/m²

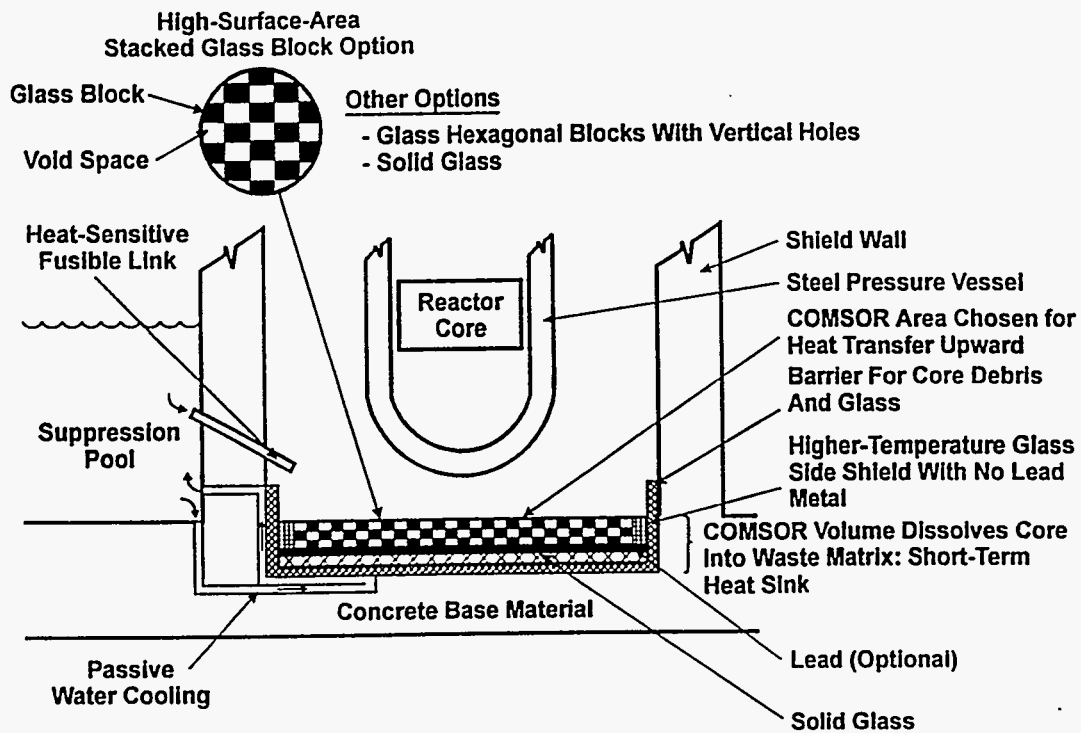

Fig. 1. Schematic of COMSORS.

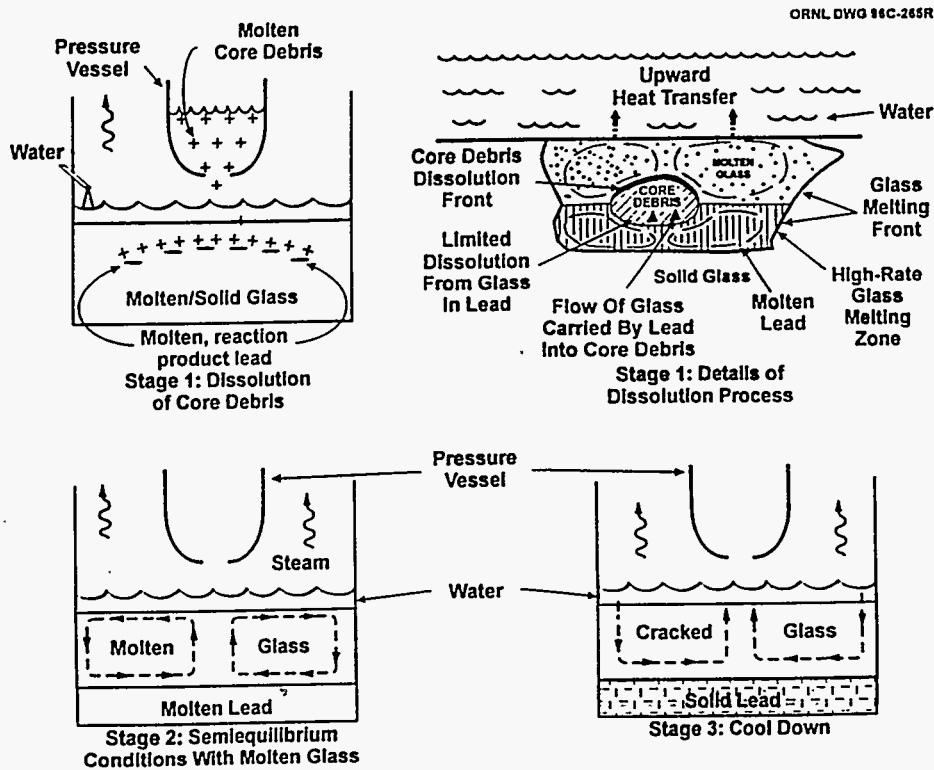
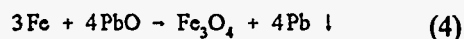
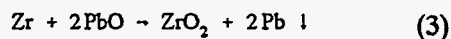

Fig. 2. Operation of COMSORS.

2. Dissolution of core debris in glass. As the melting process progresses, the uranium and fission products react and dissolve into the glass, creating an HLW glass which has relatively uniform properties because of convective molten-glass currents. To dissolve core debris fully, a special lead-borate glass has been developed which contains at least 2 moles of PbO per mole of B₂O₃. Boron oxide ensures the rapid dissolution of oxides in the core debris. Boron oxide is used in welding fluxes and other applications for which fast dissolution of oxides is required. The boron minimizes concerns about recriticality in a core-melt accident.

Traditional glasses are oxide mixtures that will dissolve oxides—but not metals. To eliminate reactive metals in core debris, PbO is incorporated into the glass. The PbO oxidizes the reactive metals, generating metal oxides and by-product lead. The oxidized products of reactive metals, such as zirconium oxide, dissolve into the glass. Typical chemical oxidation reactions include:



The high-density, molten lead metal separates from the molten glass and sinks to the bottom of the system. Lead metal is chemically inert in the expected environment. The use of PbO in the glass eliminates the further generation of combustible gases from core debris chemical reactions by preferentially reacting with reactive metals such as zirconium in the core debris. Last, lead is a liquid at temperatures between 350 and 1620°C. Natural-circulation lead currents ensure relatively uniform heat distribution under the glass over a wide range of temperatures.

The reaction product lead plus any other lead added to the system prevents agglomerations of high-density (8.5 g/cm³) core debris⁹ from melting holes in the glass (>6 g/cm³) in a few locations and attacking the containment floor. Time must be provided for core dissolution and melting of the bulk glass. Lead has a density of ~11.5 g/cm³, which is a higher density than that of the mixture generally characterized as "core debris." The lead gathers in low spots at which the glass is molten, and core debris floats off the underlying

solid glass. This movement of the core debris in turn reduces the melting of the glass below the core debris. Simultaneously, lead-convective currents transfer heat sideways to solid glass. This convective heat transfer preferentially melts glass in a horizontal plane and distributes heat uniformly across the system. The melting glass absorbs heat and provides fresh glass to dissolve additional core debris. The lead is a self-healing mechanism to prevent penetration of core debris through the glass to the containment floor.

3. Spreading of molten glass. The molten HLW glass spreads into a wide pool, thereby distributing the heat for removal by radiation to the reactor cavity above or transfer to water that spills on top of the glass from the containment. The characteristics of the core debris are changed:

Geometry. The radioactive heat source (core debris) in an unknown geometry somewhere on the containment floor is converted into a uniform heat source of known geometry in the form of a molten pool of glass.

Composition. The dissolution process creates a glass (with well-defined chemical and physical properties) that is a liquid at relatively low temperatures. In effect, the designer chooses an acceptable range of properties for efficient heat transfer by selecting the glass composition to meet performance requirements. Because the mass of the initial glass is significantly greater than the mass of the core debris, variations in the initial core debris mass and chemical composition create only limited variations in the properties of the final molten glass solution.

B. Stage 2: Semiequilibrium Conditions

In the second stage of the COMSORS response, there are semiequilibrium conditions. The core debris is dissolved into the molten glass that floats on top of a layer of molten lead metal with a thin, solid-glass layer between the water and molten glass. The efficient convective heat transfer within the molten glass limits temperatures to ~600°C. At these temperatures, insulation can limit the heat fluxes to the underlying concrete to manageable values. In the specific case analyzed, most of the heat is removed by transfer to the water above (130 kW/m²) with only small downward heat fluxes (~0.4 kW/m²).

Over periods of weeks, bottom containment temperatures would increase as heat is transferred through the insulation. Heat removal systems (heat pipes, natural circulation water loops, etc.) can be provided during the original installation of the liner of COMSORS to remove the downward heat flux and prevent long-term concrete degradation. Because of the low heat flux, simple passive heat-removal systems with limited capabilities can handle the heat flux.

C. Stage 3: Cool Down

In the third stage of the COMSORS response, the glass with dissolved core debris begins to solidify as an increased surface cooling area results in more rapid removal of heat than generation by radioactive decay heating. As the core debris cools, the glass (based on limited laboratory observations) would fracture, thus allowing water circulation through the glass-rubble bed.

IV. THERMODYNAMIC AND EXPERIMENTAL RESULTS

A thermodynamic study of the $\text{PbO-B}_2\text{O}_3$ system was conducted. All metals, except metals more noble than copper (platinum etc.), will be oxidized by the PbO in the melt. These noble metals would ultimately dissolve into the lead at the bottom of COMSORS.

Laboratory experiments have been conducted that demonstrate the dissolution of UO_2 , ZrO_2 , Al_2O_3 , Ce_2O_3 , MgO , and other oxides into glass. Oxidation-dissolution tests have demonstrated the oxidation of the following metals and alloys (followed by the dissolution of their oxides into the melt): Zircaloy-2, stainless steel, Al, U, Ce, and other metals. Figure 3 shows the partial dissolution of zircaloy clad. In this test, zircaloy clad was added to the glass, the glass was heated for a short time, and the test was terminated. The crucible was sealed in epoxy and cut in two to show the chemical reactions at the half-way point. The reaction by-product lead can clearly be seen. In other tests, the chemical reactions were run to completion with creation of a homogeneous glass. Viscosity and thermal expansion coefficients were experimentally measured. The viscosity is between 50–250 cp at 700°C , depending upon the glass composition and dissolved core debris composition.

Different glass compositions were experimentally evaluated to maximize chemical reactivity and maximize the solubility of core debris material. The

glass composition $2\text{PbO:B}_2\text{O}_3$ exhibited the highest solubility for UO_2 . With this glass composition, >30 wt % UO_2 or 30 wt % ZrO_2 was soluble into the glass at $\sim 1000^\circ\text{C}$. It was also observed that 20 wt % UO_2 with 20 wt % ZrO_2 could be dissolved in this glass at 1000°C . The uranium oxides increase the solubility of the ZrO_2 and other normally low-soluble components in molten glass systems.

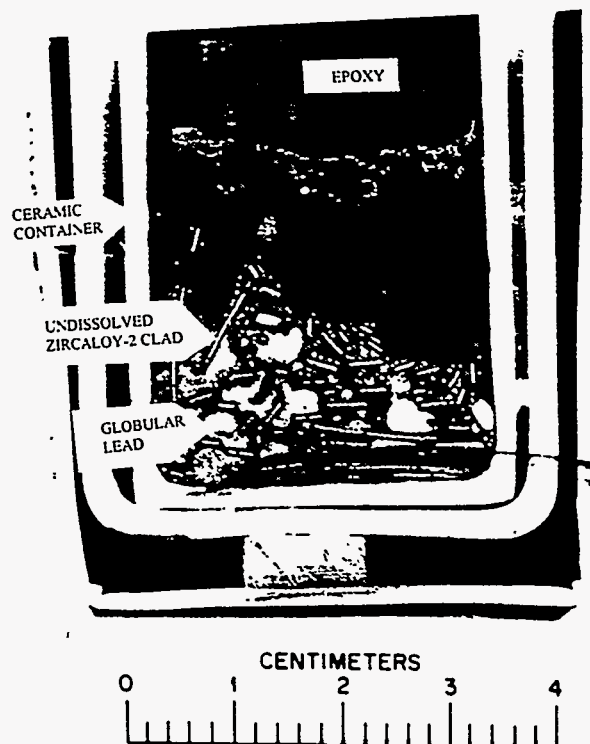

Fig. 3. Dissolution of Zircaloy.

A limited number of reaction rate experiments were conducted and reaction rates were determined to be $\sim 0.1 \text{ g/cm}^2\text{-h}$ for carbon and metals. This determination is approximately the same as that calculated from theory (see following).

V. DESIGN ENVELOPE AND MODELING

The chemistry ensures the intended COMSORS operation if there is sufficient glass present. Practical designs require limiting the quantities of glass. Two design limits were identified and investigated: excess molten-glass temperatures and excess lead temperatures.

A. Excess Molten-Glass Temperatures

Excess molten-glass temperatures can cause containment failure by high-temperature concrete destruction during Stage 2 of the COMSORS response. After debris dissolution occurs, the system is characterized by two natural circulation systems: molten glass and molten lead (Fig. 4). A glass with low viscosities at medium temperatures is required to minimize Stage 2 temperatures. A thermohydraulic model of COMSORS was developed to help us understand quasi-steady-state operation. A combination of experimental measurements and literature-derived properties were used to provide the values of key physical properties. For the specific SBWR accident response that was analyzed, the equilibrium glass temperature was $<600^{\circ}\text{C}$. The SBWR design² is somewhat more complex than that shown in Fig. 4.

There is one unique aspect of modeling a molten-glass natural-circulation system: its thermal conductivity. Glasses are optically transparent fluids at high temperatures with high rates of internal radiative heat transfer. The effective thermal conductivity is proportional to the cube of the absolute temperature. This effect implies that at system operating temperature, the effective thermal conductivity of glass is comparable to that of metals⁴. Small increases in temperature rapidly increase heat transfer in the system.

B. Excess Lead Temperatures

Excess lead temperatures can cause containment failures if sufficient core debris fails to dissolve or does not dissolve sufficiently fast into the glass (Fig. 4) during Stage 1 operations. In either case, core debris will form a solid, floating layer between the molten glass and molten lead because the core debris has a density intermediate between that of molten glass and molten lead. If a thick, insulative, undissolved, heat-generating debris layer totally covers this interface, the debris layer can heat the lead and, hence, the concrete to excessive temperatures. Partial blockage is not a concern because of good heat transfer between molten lead and glass. There are two failure mechanisms.

Solubility Limits of Core Debris in Glass. If the solubility limits of core-debris components in glass are exceeded, a layer of core debris will form. Experimental measurements (see earlier) of core debris solubility in glass define the maximum loading in the glass before this limit is exceeded and define the minimum quantity of glass required in any COMSORS design.

Dissolution Rate Limits of Core Debris in Glass.

If dissolution of core debris into the glass is too slow, a debris layer will exist after all the glass has melted. The avoidance of the formation of a layer of core debris can be viewed as a race between (a) the dissolution of the core debris and (b) the rate of lead temperature heatup.

The expected Stage 1 operation for COMSORS (assuming a monolithic glass below the reactor) is (1) core debris flowing onto the glass, (2) core debris partially reacting with the glass, and (3) formation of a core-debris layer floating on the reaction product lead. Water would be on top of the molten glass, and solid unreacted glass would be below the lead. Shortly after COMSORS initiation, from top to bottom, there would be layers of water, molten glass with dissolved core debris, undissolved core debris, molten lead, and solid glass. As the lead heats up, the solid glass begins to "melt" and form molten glass drops that would float upward through the lead to the bottom of the core debris. These glass droplets dissolve into the core debris, thus lowering its density and viscosity. Because the molten glass has a lower density than the debris, these beads would tend to bore into the core debris. Higher local temperatures accelerate the process of dissolution of glass into the core debris from the bottom. The process would continue (as glass dissolves core debris from the top and core debris dissolves glass from the bottom) until a uniform glass mixture is created.

The dissolution rates also increase with temperature. Experiments with other boron glass systems⁵ show that as temperature rises, dissolution rates rapidly increase. This increase appears to be a result of the boron oxide diffusing into the core debris; thereby lowering the melting point of the core debris by forming a borate glass and rapidly dissolving and breaking up of the debris.

Detailed chemical kinetics dissolution experiments have not yet been conducted to provide high assurance that excess lead temperatures will not occur. Only limited experiments at one set of conditions were preformed. Until such experiments are completed, the potential for high lead temperatures is the major uncertainty in COMSORS operation.

Two potential alternative COMSORS designs were identified that use engineering solutions to ensure rapid core-debris dissolution. Whether such engineering solutions are needed is currently unknown.

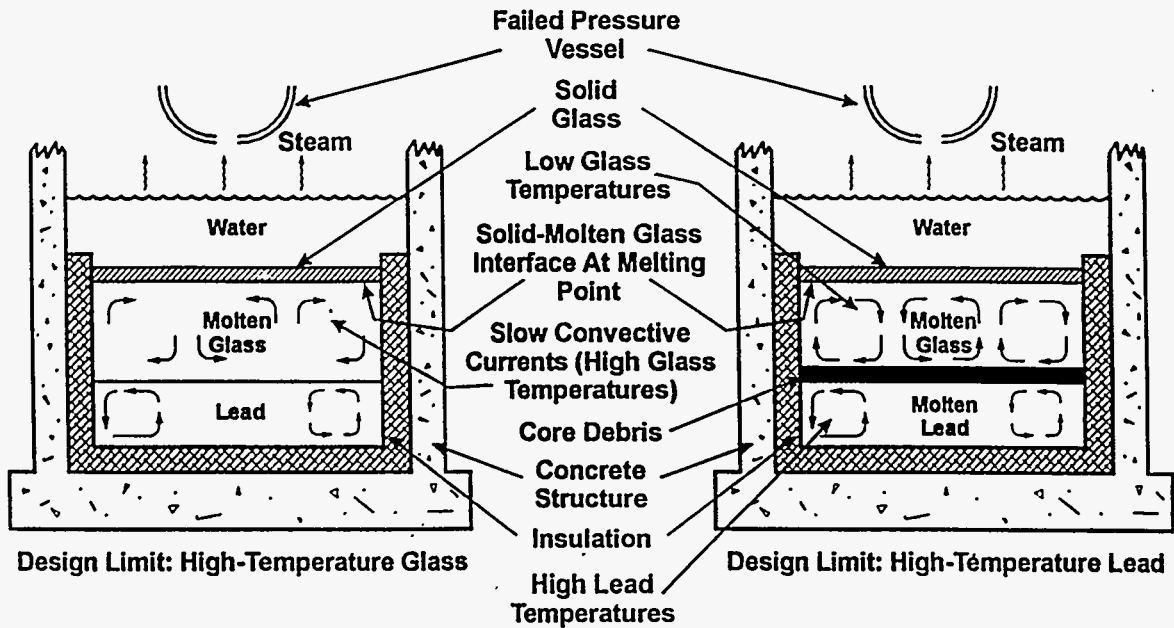

Fig. 4. COMSORS design limits.

Accelerated dissolution rate. The rate of dissolution depends upon the surface area between the glass and the core debris. The surface area is a design variable. COMSORS can be built of bricks with space between the bricks or hexagonal blocks with vertical holes. A typical design of hexagonal block might have vertical holes 3 to 5 cm in diam. on a triangular spacing of 10 to 15 cm. In such geometries, the molten core debris early in the accident would flow into the channels, initially freeze in the channels, reheat, and dissolve into the glass as the glass melts. Analysis and limited experimental measurements indicate that with appropriate geometry, the dissolution times are short and that overheating of lead will not occur.

Additional Cooling. The lead can be cooled to provide more time for dissolution of the core debris using cooling pipes from the containment suppression pools. Cooling molten lead anywhere provides cooling everywhere under COMSORS due to convective lead currents.

VI. RELATED TECHNOLOGIES

COMSORS is a new technology, but there are related technologies. Developmental work was performed on a borax ($\text{Na}_2\text{B}_4\text{O}_9$) core-catcher for 1000-MW(e) [2700-MW(t)] gas-cooled, fast reactors in Germany⁵. This was a chemical core catcher in which the oxides dissolved into the borax and a separate molten layer of metal was formed under the molten borax.

COMSORS also has similarities to HLW glass vitrification systems. Many HLW melter dissolve fission products into molten glass with the HLW fed as an aqueous slurry to the melter. This process results in a configuration similar to COMSORS: water on top of molten glass with internally generated heat sources (joule heating, induction heating, decay heat). Heat transfer correlations, safety analysis results^{6,7}, and other integral data are applicable to COMSORS. Tests in glass melter have shown that up to 600 kW/m^2 can be transferred from molten glass to water⁸.

Last, the COMSORS lead-borate dissolution glass is used in various analytical tests and has become the preferred solvent used in high-temperature calorimetry tests for determination of the thermodynamic properties of complex minerals⁹. It is used in these applications because of its extraordinary dissolution capabilities. For all of these applications, the preferred dissolution glass is the 2PbO:B₂O₃ mixture.

VII. SUMMARY

COMSORS is a new concept to terminate core-melt accidents in LWRs. Initial small-scale scoping experiments, preliminary analysis, and experimental data from other sources (HLW-glass melters, etc.) support its feasibility. Added analytical and experimental work is required to provide high confidence in the concept, to optimize the design, and to address engineering issues.

REFERENCES

1. C. W. Forsberg, E. C. Beahm, and G. W. Parker, "Reactor Accident Meltdown Limit and Control System," U.S. Patent 5,410,577 (April 25, 1995).
2. C. W. Forsberg, et al., *Termination of Light-Water Reactor Core-Melt Accidents With A Chemical Core Catcher: The Core Melt Source Reduction System (COMSORS)*, ORNL-6899, Lockheed Martin Energy Systems, Inc., Oak Ridge National Laboratory, Oak Ridge, Tennessee (September 1996).
3. G. W. Parker, L. J. Ott, and S. A. Hodge, "Small-Scale BWR Core Debris Eutectics Formation and Melting Experiment," *Nuclear Engineering Design*, 121,341 (1990).
4. R. Gardon, "A Review of Radiant Heat Transfer in Glass," *J. Am. Ceramic Soc.*, 44:305-12 (1961).
5. M. D. Dalle-Donne, S. Dorner, and G. Schumacher, "Development Work for a Borax Internal Core-Catcher for Gas-Cooled Fast Reactor," *Nucl. Tech.* 39,138 (1978).
6. M. N. Hutcherson, H. K. Fanske, R. E. Henry, and T. J. Marciniak, *Assessment of the Potential and Consequences of a Hypothetical Steam Explosion in the Defense Waste Processing Facility Glass Melter*, FAI/83-8, Fauske & Associates, Inc., Burr Ridge, Illinois (1983).
7. R. F. Schumacher, M. E. Smith, and J. F. Sproull, *Review of Background Applicable to the Potential for a Steam Explosion in the DWPF Melter*, WSRC-RD-91-15, Westinghouse Savannah River Company, Aiken, South Carolina (June 19, 1991).
8. L. J. Mahoney, "Pilot Plant Demonstration of the Defense Waste Processing Facility (DWPF) Melter Concepts," *Spectrum*, pp. 746, American Nuclear Society, La Grange Park, Illinois (1986).
9. A. Navrotsky, "Progress and New Directions in High Temperature Calorimetry Revisited," *Phys. Chem. Min.* (in press).