

CP 3636

CONF-961203--1  
AGU 1996 Fall Meeting

RECEIVED  
APR 23 1987  
OSTI

# Formation of Current Sheets in Magnetohydrostatic Atmospheres (MHS)

G. S. Choe and C. Z. Cheng

*Plasma Physics Laboratory, Princeton University  
Princeton, NJ 08543-0451*

DISTRIBUTION OF THIS DOCUMENT IS UNLIMITED 

MASTER

**DISCLAIMER**

**Portions of this document may be illegible in electronic image products. Images are produced from the best available original document.**

## **DISCLAIMER**

**This report was prepared as an account of work sponsored by an agency of the United States Government. Neither the United States Government nor any agency thereof, nor any of their employees, make any warranty, express or implied, or assumes any legal liability or responsibility for the accuracy, completeness, or usefulness of any information, apparatus, product, or process disclosed, or represents that its use would not infringe privately owned rights. Reference herein to any specific commercial product, process, or service by trade name, trademark, manufacturer, or otherwise does not necessarily constitute or imply its endorsement, recommendation, or favoring by the United States Government or any agency thereof. The views and opinions of authors expressed herein do not necessarily state or reflect those of the United States Government or any agency thereof.**

## ABSTRACT

It is demonstrated that a 2-D magnetic field configuration in a magnetohydrostatic equilibrium without any nullpoint can be deformed into a configuration with current sheets, i.e., tangential discontinuities, either by temperature change or by footpoint displacement.

The magnetohydrostatic solutions by Low (A & Ap, 1992), which have a quadrupolar field geometry, are chosen as our initial configurations.

When the whole atmosphere is uniformly heated, the expansion of plasma is more effective in the outer flux tubes than in the inner ones. The expanding plasma pushes out the field lines in each bipolar region so that a current sheet of a finite length is formed where the field lines from each region come into contact. The resulting pressure profile at the base has pressure maxima at the center of each bipolar regions. The smooth equilibrium solution with the same pressure distribution contains an X-point.

If the pressure is initially higher in the outer tubes than in the inner ones, cooling of the atmosphere can also lead to current sheet formation. As the pressure scale height decreases by cooling, the magnetic field pressure dominates the plasma pressure in the upper part of the flux tubes. The subsequent expansion of field lines creates a tangential discontinuity. If resistivity is considered in this weak equilibrium state, magnetic reconnection results in a new Kippenhahn-Schlüter type field configuration with a magnetic island. It is expected that a prominence can stably reside within the magnetic island.

When the field footpoints undergo a shearing motion with a continuous shearing profile, a current sheet can be formed beyond a critical amount of shear.

Our results suggest that the formation of a current sheet and the subsequent magnetic reconnection can be ubiquitous in the solar atmosphere. The resulting field configurations are quite favorable for prominence formation.

# MOTIVATION OF THE STUDY

- A current sheet is a pre-condition for **magnetic reconnection**, which is considered to play a central role in **solar flares** and **coronal heating**.
- **Solar prominences** are likely to form in current sheets because they are mostly observed above the polarity inversion lines, especially between two bipolar regions.
- Considering the commonness of the above phenomena, current sheet formation must be quite a **general process**, but is not well understood.

MHS solutions

$$\vec{J} \times \vec{B} = \nabla p - \rho \vec{g}$$

# GOAL OF THE STUDY

We construct MHS equilibria with current sheets of different geometry by various physical processes. Since a field configuration with a null-point tends to be deformed to a current sheet, we start from a smooth equilibrium without any null-points. Specifically, we consider two different types of change in the environment of the system.

## 1. Thermodynamic Changes

How does the equilibrium change when the system is either heated or cooled? If a current sheet is to form, what is the critical temperature at which the system enter the weak equilibrium state?

## 2. Motion of Field Line Footpoints at the Boundary

Can a current sheet be formed if the boundary motion is continuous in space so that no discontinuity in field line connectivity is allowed? What is the critical amount of footpoint displacement?

## Problem Setting

### Case 1.

Let a magnetoplasma of temperature  $T_0$  be in MHS equilibrium under gravity.

If the temperature of the whole atmosphere changes, in what new equilibrium state will the system end up?

### Constraints

1. The bottom boundary is considered to be rigid, i.e., there is no plasma flow across the boundary.
2. There is no resistivity and the ideal MHD condition is satisfied, i.e., there is neither plasma diffusion across the field line nor magnetic reconnection.

Due to these constraints, conserved is the mass per flux tube, which is

$$m(A) = \int_{\text{along } A} \frac{\rho}{|B|} dl$$

Case 1A : The atmosphere is uniformly heated.  
 $T > T_0$

Case 1B : The atmosphere is uniformly cooled.  
 $T < T_0$

## Case 2.

A plasma embedding a quadrupolar magnetic field is in equilibrium. If we impose a spatially continuous footpoint motion, how will the system evolve?

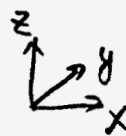

$$\vec{B}_y = \vec{B}_y$$

$$\vec{B}_p = \vec{B}_x + \vec{B}_z$$



In Case 2, we also assumed the same constraints as in Case 1. In a low  $\beta$  plasma, however, the conservation of mass or the gravity do not play an important role although they are strictly considered in our study.

The shear of footpoint displacement is defined by

$$\Sigma(A) = \int_{\text{along } A} \frac{B_t}{|B_p|} dl$$

where  $B_t$  is the toroidal field and  $B_p$  the poloidal field.

Thus the increase of shear corresponds to the increase of heat content per flux tube. However, the difference between Cases 1 and 2 can be seen in the fact that

$$B_t = B_t(A) \quad \text{while}$$

$$\rho = \rho_0(A) \exp\left(-\frac{z}{H}\right)$$

$$\text{where } H = \frac{k_B T}{m g}$$

# ANALYTICAL SOLUTION OF MHS EQUILIBRIUM

- **Linear Grad-Shafranov Equation for MHS Equilibrium**

$$\nabla^2 A + \frac{dP}{dA} \exp\left(-\frac{z}{H}\right) = 0$$

$$P(A) = p(A, z = 0) = aA^2 + p_0$$

$$p(A, z) = P(A) \exp\left(-\frac{z}{H}\right)$$

- **Solutions With a Periodic Quadrupolar Field Geometry (Low, 1992)**

- (i) **Potential Field ( $a = 0$ )**

$$A(x, z) = \frac{B_0}{k} \left[ \exp(-kz) \cos kx - a_3 \exp(-3kz) \cos 3kx \right]$$

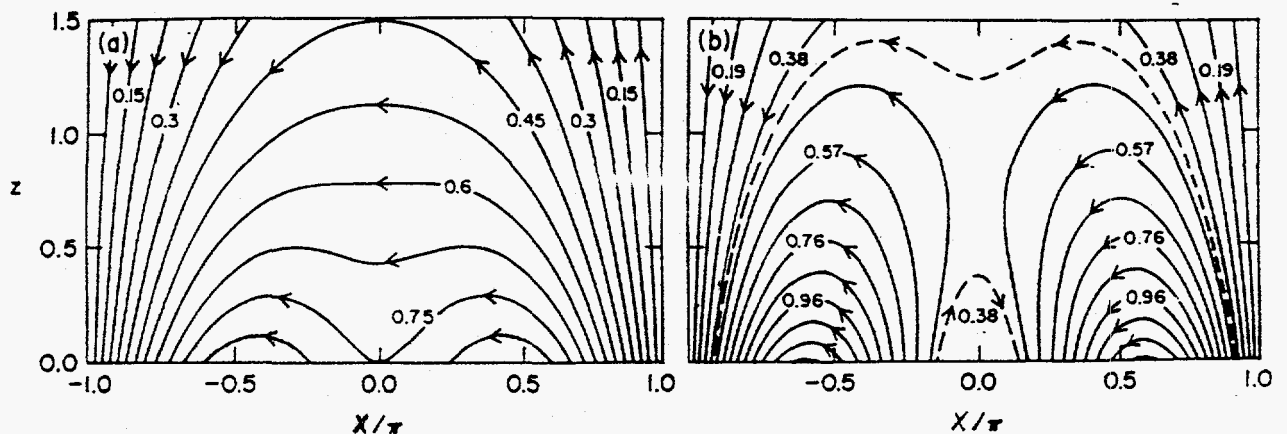

Fig. 1a and b. The potential fields generated by Eq. (12) for a  $a_3 = 0.25$  and b  $a_3 = 0.70$ , with  $k = 0.5$ . The magnetic lines of force shown are contours of constant stream function  $Ak/B_0$ , drawn at a constant increment in  $A$  as is evident from the contour values given. In a, the shaded regions are bipolar fields bounded by the separatrix line of force  $Ak/B_0 = 0.75$ . In b, the dashed lines are lines of force additional to those provided at the constant increment in  $Ak/B_0$ , which serve to bring out the presence of an X-type magnetic neutral point

(ii)  $a < 0$ ; Pressure Depletion in the Lower Arcades

$$A(x, z) = \frac{B_0}{k} \left( \frac{I_s(|q| \exp(-\frac{z}{2H}))}{I_s(|q|)} \cos kx - a_3 \frac{I_{3s}(|q| \exp(-\frac{z}{2H}))}{I_{3s}(|q|)} \cos 3kx \right)$$

where  $s = \pm 2kH$  and  $q^2 = 8aH^2$

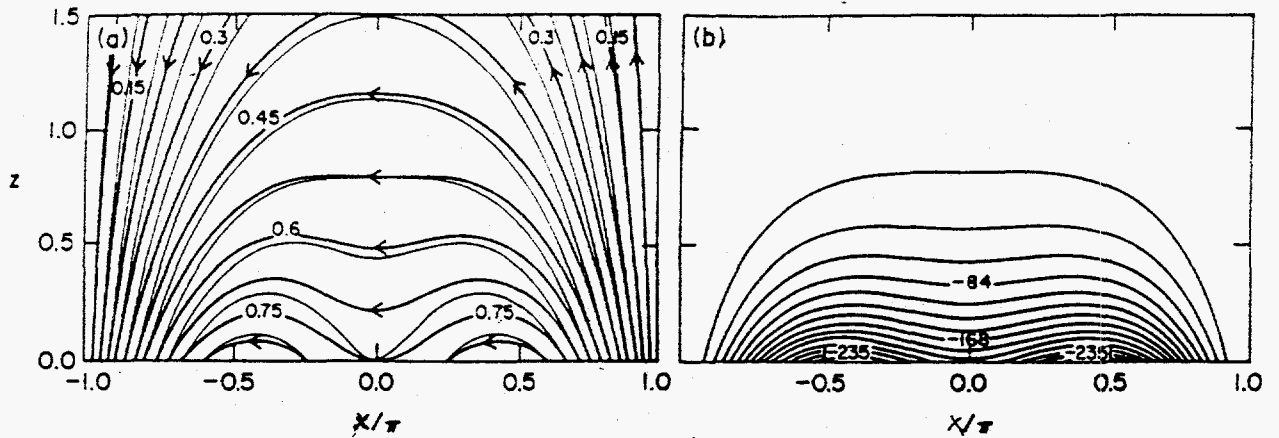

Fig. 2a and b. The case of  $a_3 = 0.25$ ,  $a = -1/8\pi$  showing a the non-potential, equilibrium magnetic field compressed downward relative to the initial potential field, and b the contours of constant, negative departure  $\Delta p$  of the pressure from the initial plane-parallel distribution. In this and subsequent figures, we set  $k = H = 0.5$ . In a, the magnetic lines of force shown as thick arrowed lines are superposed upon the lines of force (thin, unarrowed lines) of the initial field. The same set of lines of force are drawn so that each corresponding pair of lines of force from the initial and final states are shown rooted to the same point at the boundary, as an aid to visualization of the magnetic field evolution. The contours of  $\Delta p$  in b are plotted at a constant increment in some arbitrary unit

(iii)  $a > 0$ ; Higher Pressure in the Lower Arcades

$$A(x, z) = \frac{B_0}{k} \left( \frac{J_s(q \exp(-\frac{z}{2H}))}{J_s(q)} \cos kx - a_3 \frac{J_{3s}(q \exp(-\frac{z}{2H}))}{J_{3s}(q)} \cos 3kx \right)$$

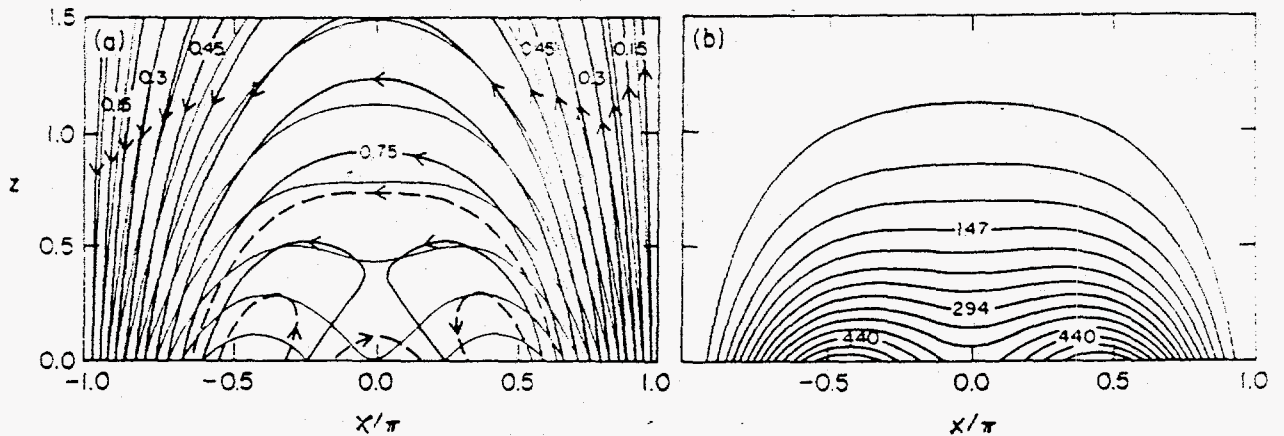

Fig. 5a and b. The case of  $a_1 = 0.25$ ,  $a = 1.74/8\pi$  shown in the same format as in Fig. 2, showing that the continuous solution with a positive  $\Delta\rho$  has a non-potential, equilibrium magnetic field with a magnetic neutral point in the domain. Additional (dashed) lines of force are drawn to bring out the field geometry due to the presence of a neutral point.

# NUMERICAL METHODS

## 1. Cases 1A and 1B

To obtain an MHS equilibrium for a given temperature, a magnetofrictional method is employed as follows.

$$\frac{\partial \rho}{\partial t} = -\nabla \cdot (\rho \vec{v})$$

$$\rho \left( \frac{\partial \vec{v}}{\partial t} + \vec{v} \cdot \nabla \vec{v} \right) = -\nabla p + J \times B + \rho \vec{g} + \nabla \cdot \mu \vec{v} - \alpha \rho \vec{v}$$

$$\frac{\partial A}{\partial t} = -\vec{v} \cdot \nabla A$$

$$T = \text{const.}$$

$$\vec{B} = \nabla A \times \nabla \psi$$

where  $\alpha$  is a friction coefficient.

## 2. Case 2

To follow the quasi-static evolution of the magnetic field, a time-dependent MHD simulation is performed with a foot-point velocity as a boundary condition.

## Case 1A

In the initial equilibrium, the magnetic field is potential, i.e.,  $\nabla^2 A = 0$ , and the pressure is a function of  $z$  only.

$$A(x, z) = \frac{B_0}{k} [\exp(-kz) \cos kx - a_3 \exp(-3kz) \cos 3kx]$$

$$k = \frac{\pi}{L_x} \quad L_x = 2 \quad a_3 = 0.31$$

$$P(z) = P_0 \exp\left(-\frac{z}{H}\right)$$

$$H = 1$$

$P_0$  is given such that

$$\beta(x = \pm L_x, z = 0) = 0.2$$

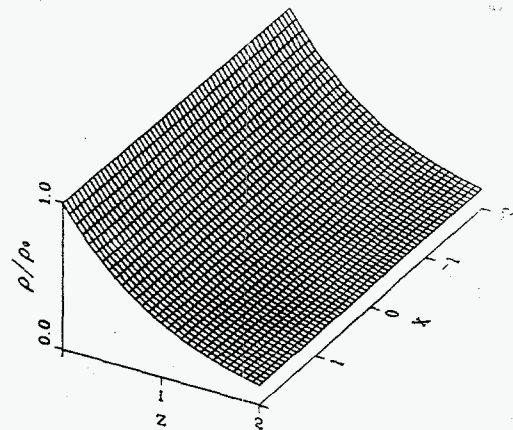
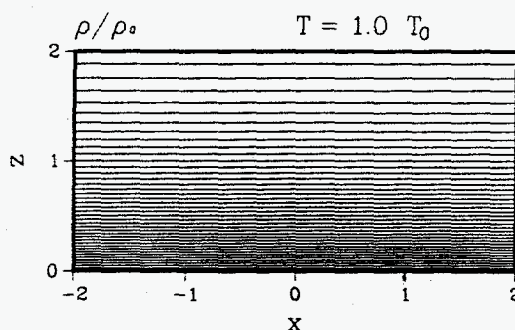
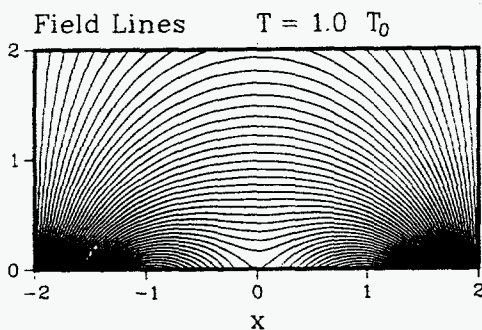

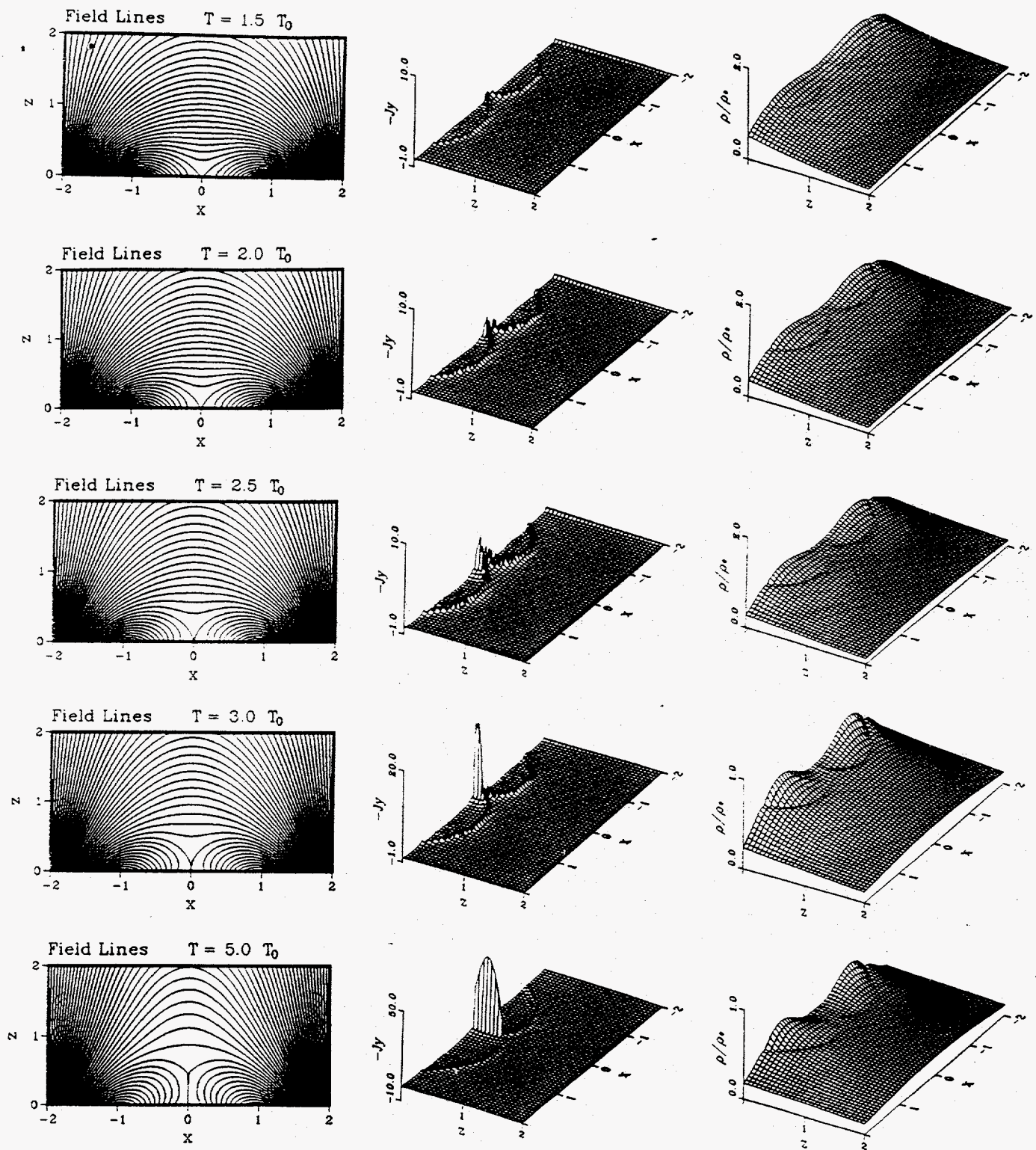

Case 1A. Field lines, current density and density are shown. The current sheet starts to form about  $T \sim 2 T_0$  at the origin and grows in length with increasing  $T$ . In the current sheet, the current density should be infinite, but the numerical value is finite.

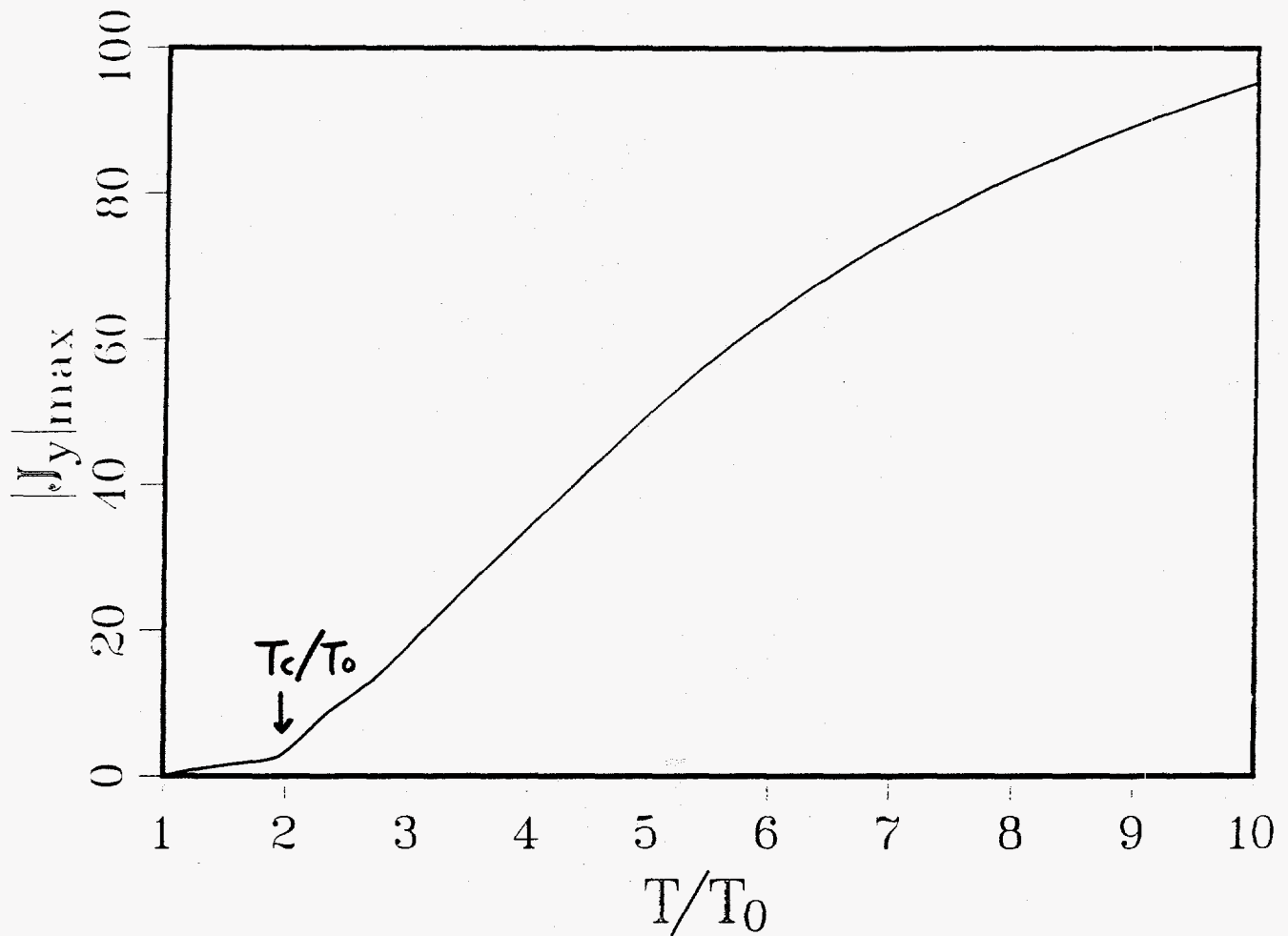

The maximum current density in the domain versus temperature. The critical temperature ( $T_c$ ) for current sheet formation in this case is near  $T=2T_0$ . Note that for  $T > T_c$  the given current density is just the numerically evaluated value.



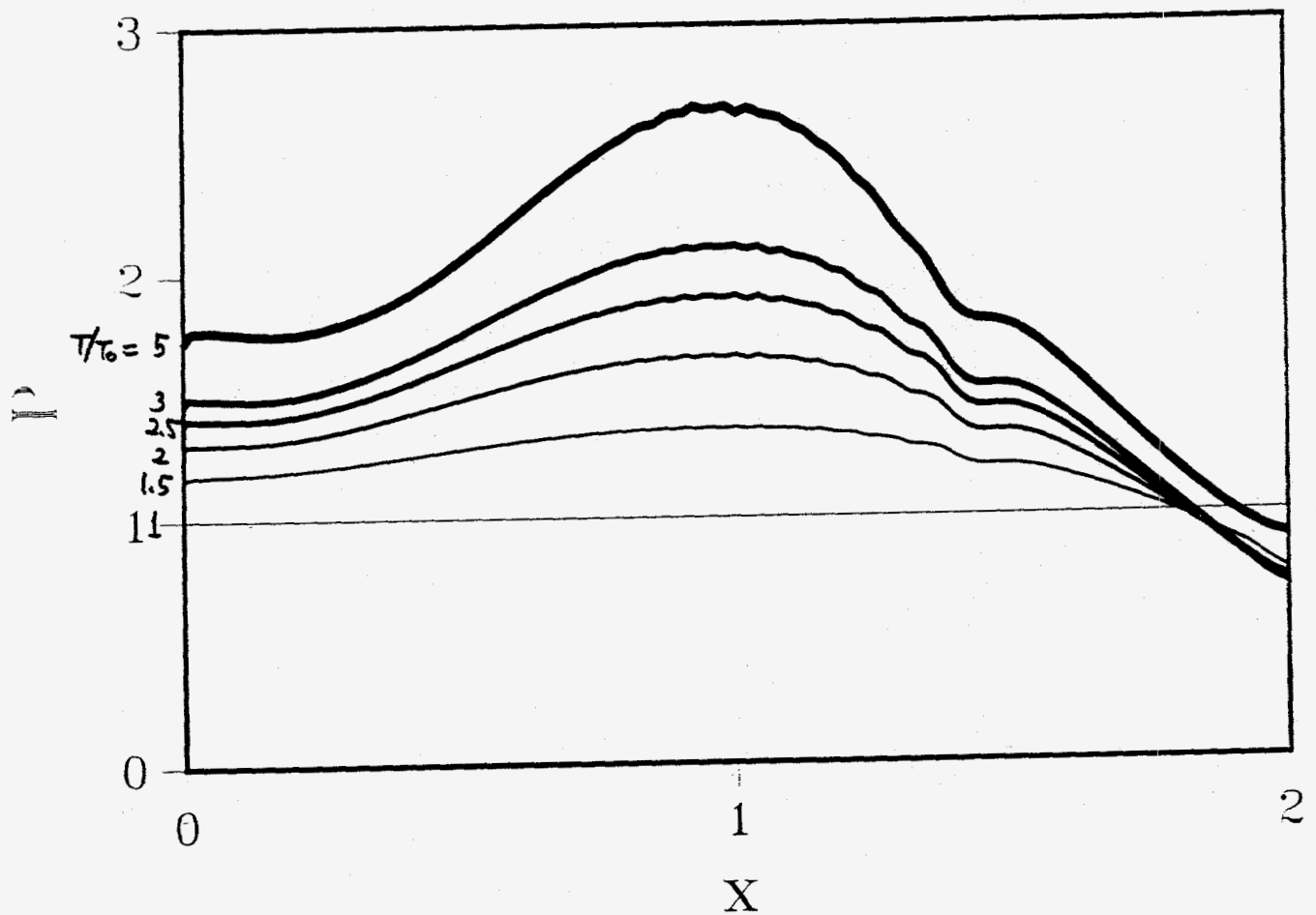

Pressure along the bottom boundary ( $z=0$ ) for different temperatures. The pressure in the center of the lowerlying arcades ( $X \sim 1$ ) becomes larger with increasing  $T$  because plasma expansion is most inhibited there. On the contrary, plasma can freely expand in the outer flux tubes. By the pressure difference between these two regions, the lowerlying arcades are pushed toward each other.

# Case 1B

In the initial equilibrium, the pressure gets larger as going to outer flux tubes.

$$p(A, z) = (aA^2 + p_0) \exp\left(-\frac{z}{H}\right)$$

$$a = -1.5 / (2\pi)^2 < 0, \quad H = 1$$

The field lines thus lie compressed downward compared to the corresponding potential field.

The equilibrium field is given by

$$A(x, z) = \frac{B_0}{4} \left( \frac{I_5(|\theta| \exp(-\frac{z}{2H}))}{I_5(|\theta|)} \cos kx - a_2 \frac{I_{35}(|\theta| \exp(-\frac{z}{2H}))}{I_{35}(|\theta|)} \cos 3kx \right)$$

$$s = 2kH = \frac{1}{2}, \quad a_2 = 0.69, \quad q^2 = 8aH^2$$

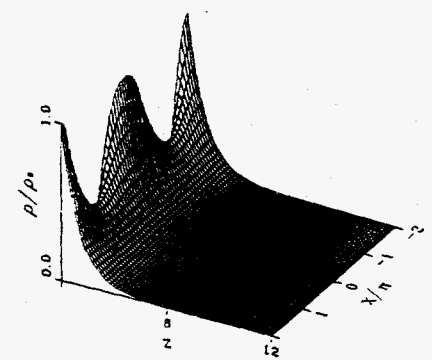
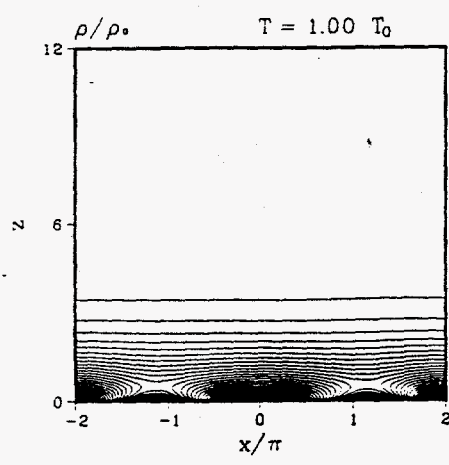
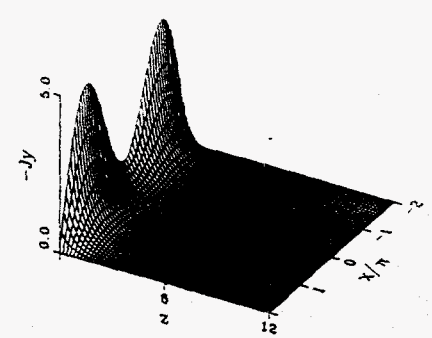
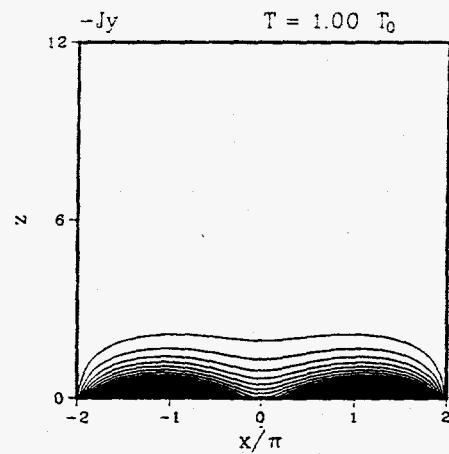
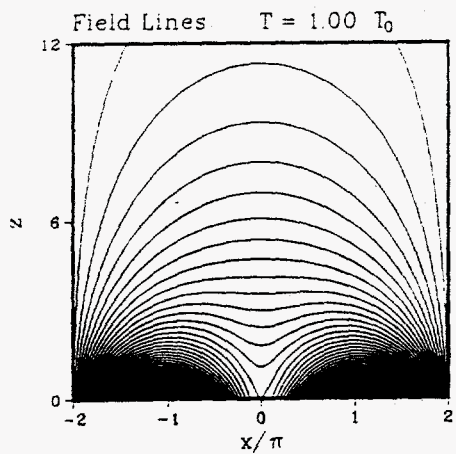

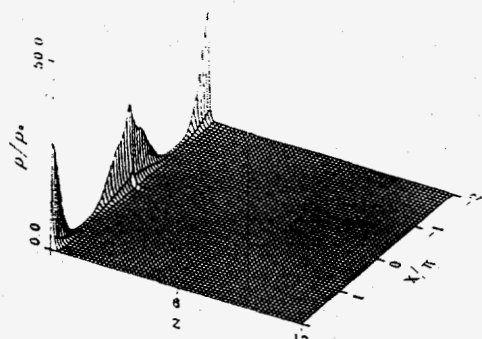
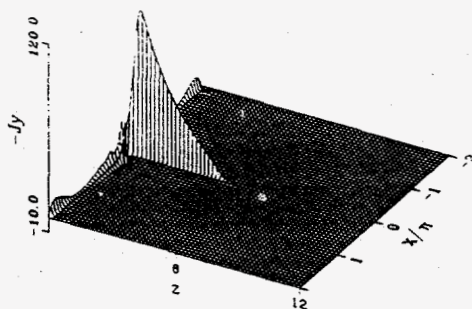
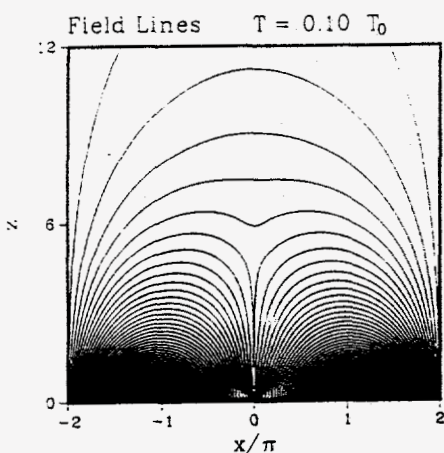
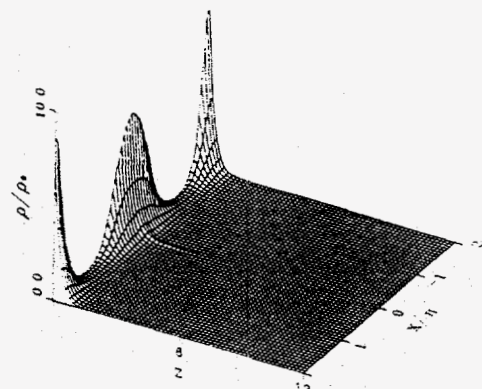
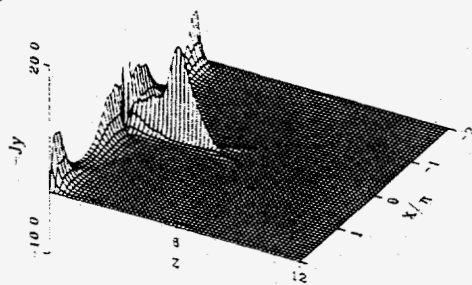
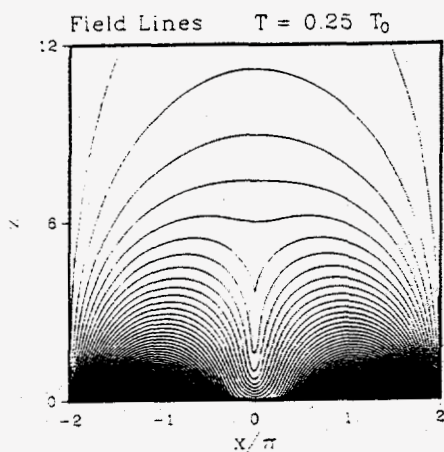
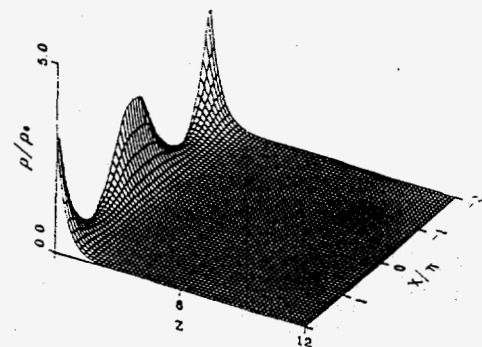
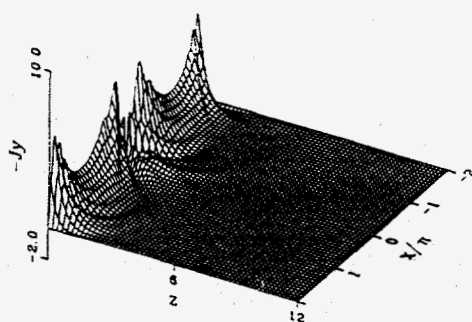
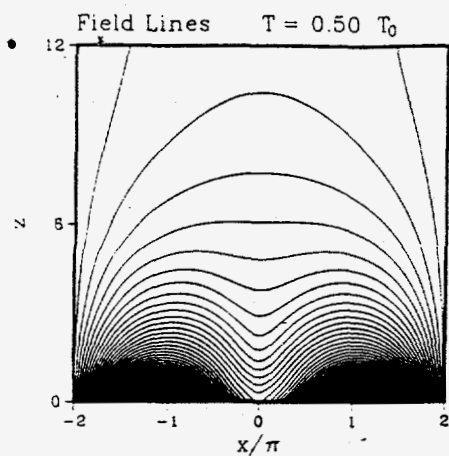

Case 1B. Field lines, current density and density are shown. The critical temperature for current sheet formation in this case is located between  $0.2 T_0$  and  $0.1 T_0$ .

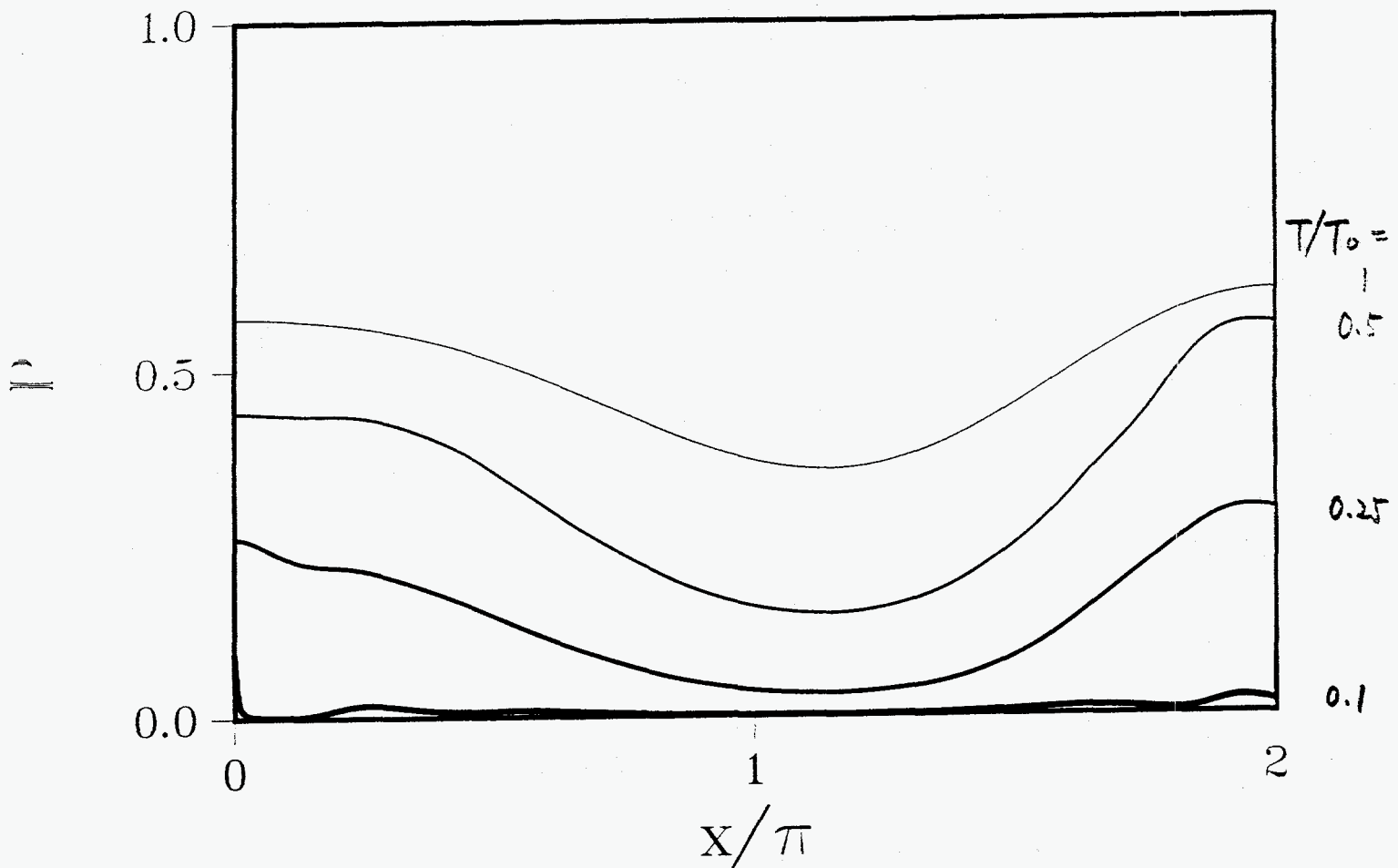

Pressure along the line parallel to the  $x$ -axis at  $z = 0.5H$  for different temperatures. The pressure difference between the inner and outer flux tubes diminishes near the critical temperature. Therefore, the magnetic field in the upper atmosphere can no longer be held down. The expanding lowerlying bipolar arcades finally come into contact and form a current sheet.

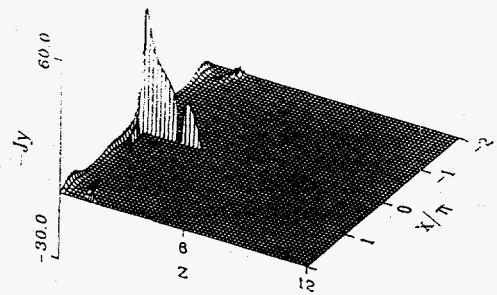
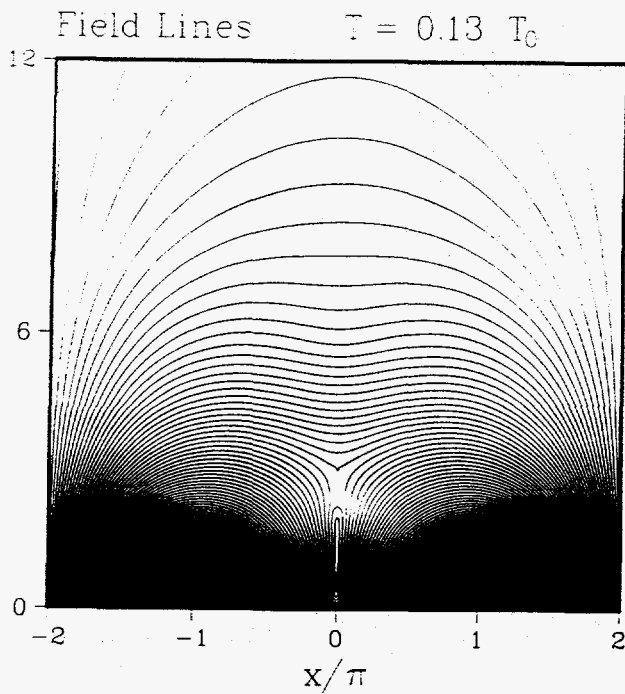
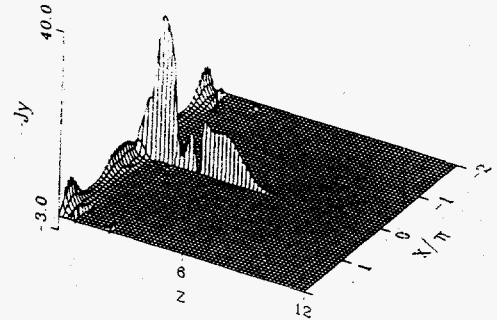
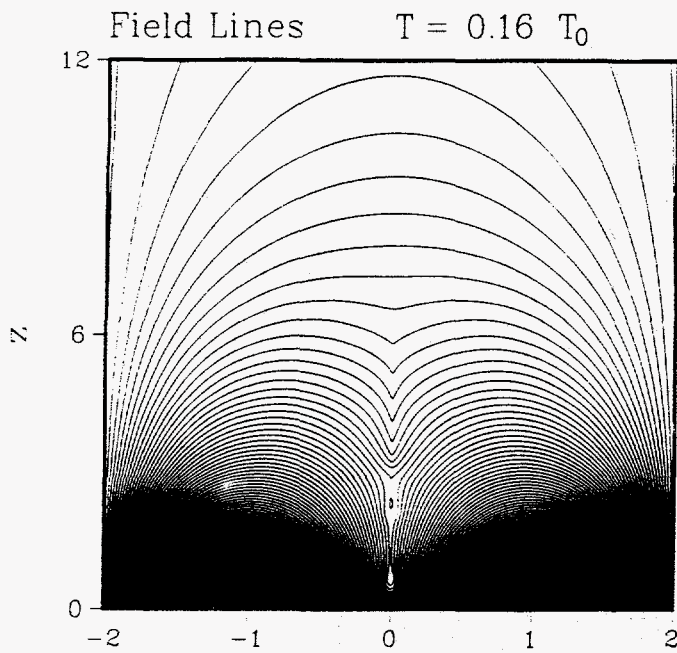

The resistive evolution under cooling.

Resistivity ( $R_m \sim 10^3$ ) is imposed to the equilibrium configuration at  $T = 0.25 T_0$  and temperature is continuously lowered. The two magnetic islands shown at  $T = 0.16 T_0$  merge later and form an elongated island at  $T = 0.13 T_0$ .

Field Lines

$T = 0.13 T_0$

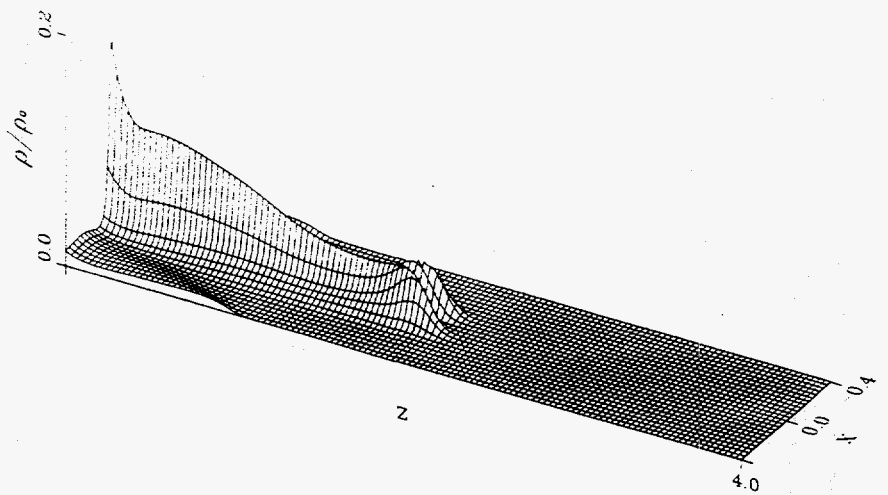
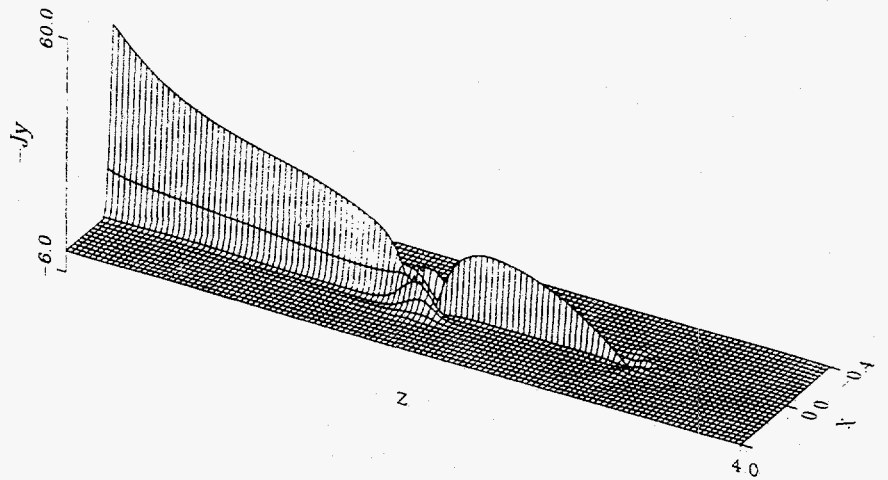
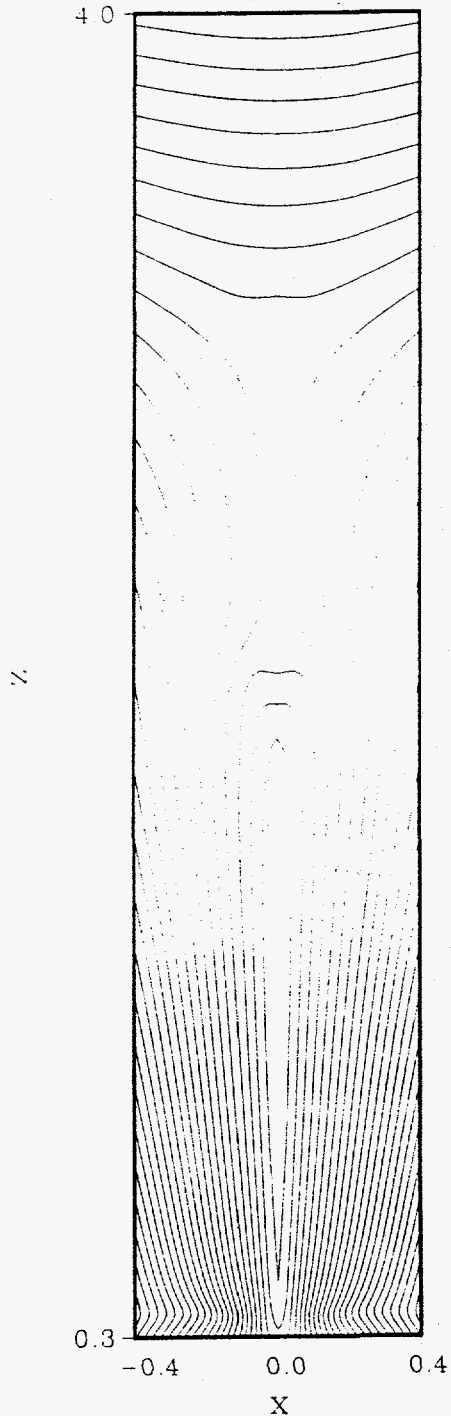

A zoomed view of field lines, current density and mass density around the magnetic island and the X-point at  $T = 0.13 T_0$  in the resistive evolution.



## Case 2

In the initial equilibrium, the magnetic field is potential and embedded in a stratified atmosphere.

The plasma  $\beta$  is taken to be low ( $\beta \sim 0.005$  at  $x = \pm 1, z = 0$ ).

The maximum shearing speed is  $0.0025 v_A$ .

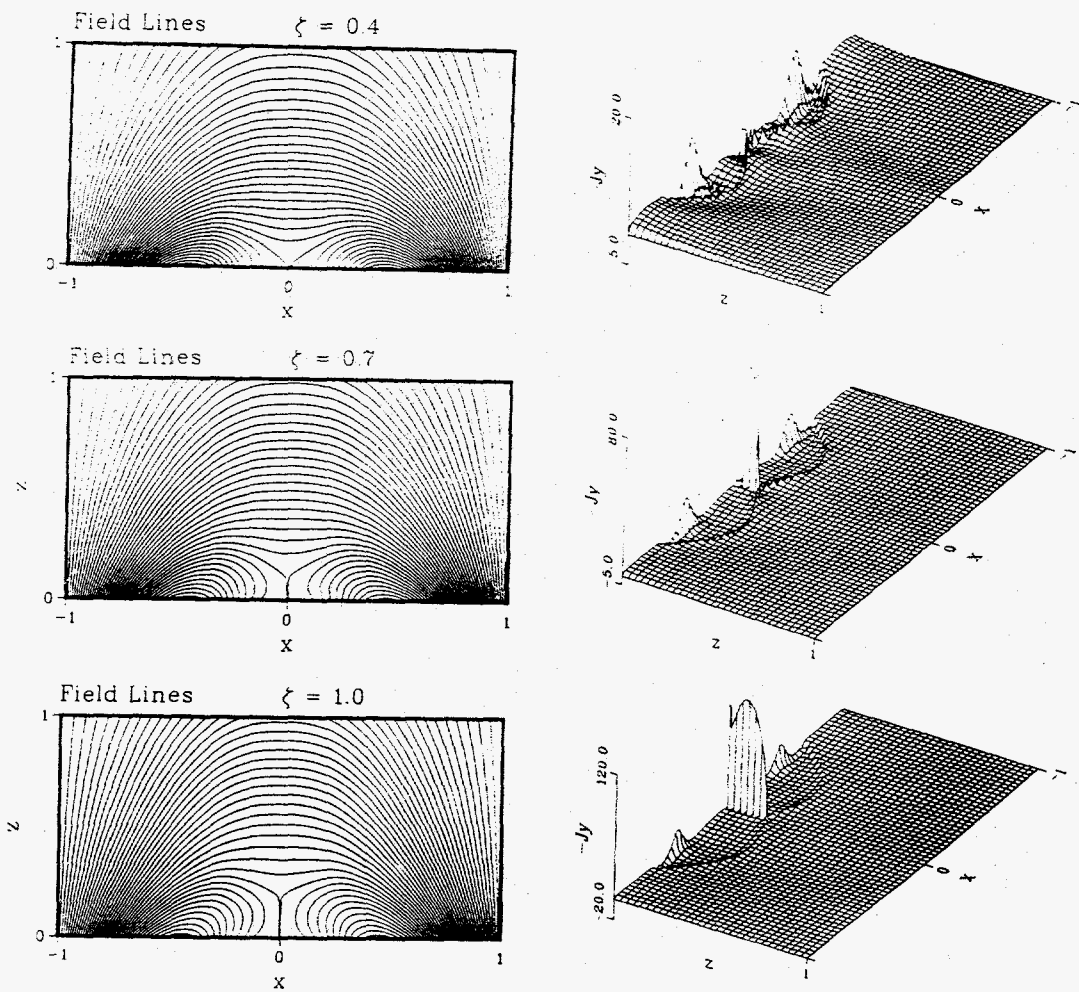

Field lines and current density are shown for Case 2. The critical shear is just above  $\zeta = 0.4$ .

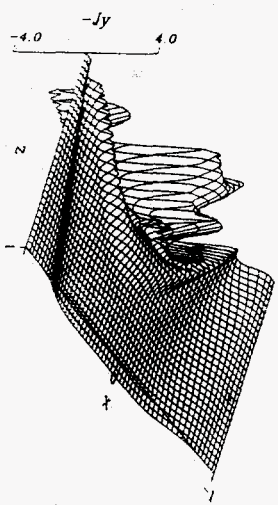
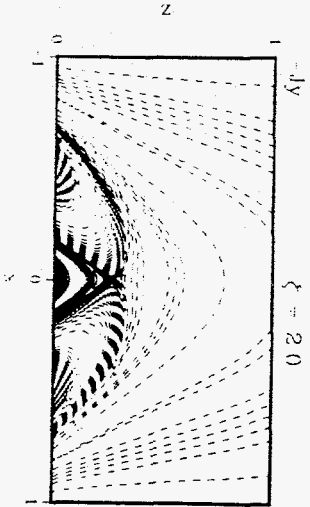
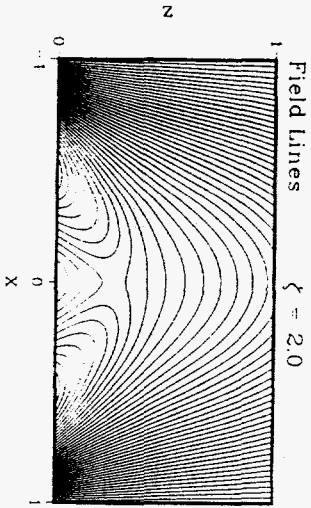
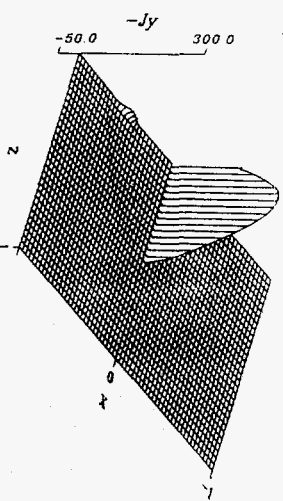
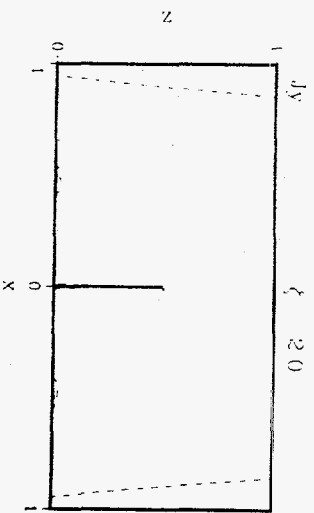
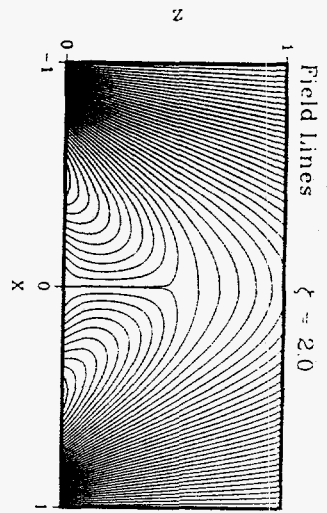

Resistive evolution of the sheared magnetic field.  
 Resistivity ( $R_m \sim 10^4$ ) is imposed to the pre-sheared field of  $S=2.0$  and no more shearing motion is given.  
 The current sheet totally disappears in the end.



# SUMMARY

We show that a magnetohydrostatic equilibrium can evolve into a configuration with a tangential discontinuity in various ways even though there exists no null-point in the initial field configuration.

## 1. Thermodynamic Variations

- When an atmosphere embedding a quadrupolar magnetic field is heated, the plasma pressure increases most in the center of the lowerlying arcades. This plasma pressure pushes the arcades towards each other to form a current sheet.
- When the magnetic field in equilibrium is confined by the outside plasma pressure, drainage of material by plasma cooling can cause expansion of the magnetic field in the upper atmosphere, where a current sheet can be formed.

## 2. Footpoint Motions

- Even when the footpoint motion is spatially continuous, expansion of the lowerlying arcades by shearing can expel the field of the overlying arcade and form a tangential discontinuity.