



ERNEST ORLANDO LAWRENCE BERKELEY NATIONAL LABORATORY

Vadose Zone Monitoring System Installation Report for McClellan AFB

P. Zawislanski, B. Faybishenko, A. James,
B. Freifeld, and R. Salve
Earth Sciences Division

RECEIVED

MAY 12 1997

OSTI

October 1996



MASTER

DISTRIBUTION OF THIS DOCUMENT IS UNLIMITED

DISCLAIMER

This document was prepared as an account of work sponsored by the United States Government. While this document is believed to contain correct information, neither the United States Government nor any agency thereof, nor The Regents of the University of California, nor any of their employees, makes any warranty, express or implied, or assumes any legal responsibility for the accuracy, completeness, or usefulness of any information, apparatus, product, or process disclosed, or represents that its use would not infringe privately owned rights. Reference herein to any specific commercial product, process, or service by its trade name, trademark, manufacturer, or otherwise, does not necessarily constitute or imply its endorsement, recommendation, or favoring by the United States Government or any agency thereof, or The Regents of the University of California. The views and opinions of authors expressed herein do not necessarily state or reflect those of the United States Government or any agency thereof, or The Regents of the University of California.

Available to DOE and DOE Contractors
from the Office of Scientific and Technical Information
P.O. Box 62, Oak Ridge, TN 37831
Prices available from (615) 376-8401

Available to the public from the
National Technical Information Service
U.S. Department of Commerce
5285 Port Royal Road, Springfield, VA 22161

Ernest Orlando Lawrence Berkeley National Laboratory
is an equal opportunity employer.

**Vadose Zone Monitoring System
Installation Report for McClellan AFB**

P. Zawislanski, B. Faybishenko, A. James, B. Freifeld, R. Salve

**Earth Sciences Division
Ernest Orlando Lawrence Berkeley National Laboratory
Berkeley, CA 94720**

October 31, 1996

This work was supported by the U.S. Department of Defense under Military Interdepartmental Purchase Request FD2040-96-74020EM to the Ernest Orlando Lawrence Berkeley National Laboratory, managed for the U.S. Department of Energy under contract DE-AC03-76SF00098.

DISCLAIMER

**Portions of this document may be illegible
in electronic image products. Images are
produced from the best available original
document.**

TABLE OF CONTENTS

| | |
|--|-----------|
| TABLE OF CONTENTS | 2 |
| LIST OF TABLES | 3 |
| LIST OF FIGURES | 3 |
| ABSTRACT | 4 |
| 1.0 INTRODUCTION | 4 |
| 1.1 Project Description..... | 4 |
| 1.2 Site Description..... | 4 |
| 1.3 Geology | 4 |
| 2.0 VZMS DESIGN | 5 |
| 2.1 General Design | 5 |
| 2.2 Instrument Design..... | 7 |
| 2.2.1 Tensiometer..... | 7 |
| 2.2.2 Suction Lysimeter..... | 9 |
| 2.2.3 Soil Gas Probe..... | 10 |
| 2.2.4 Thermistor | 11 |
| 2.2.5 Neutron Probe..... | 12 |
| 3.0 VZMS INSTALLATION | 12 |
| 3.1 Drilling and Sampling | 12 |
| 3.2 Criteria for Instrument Location | 13 |
| 3.2.1 Lithology..... | 13 |
| 3.2.2 Soil-Gas Analysis | 13 |
| 3.3 VZMS Instrument Installation Procedures | 19 |
| 3.4 Surface Completion..... | 19 |
| 4.0 PRELIMINARY RESULTS | 22 |
| 4.1 Laboratory Testing of Field Soil Samples..... | 22 |
| 4.2 Particle Size Analyses | 22 |
| 4.3 Neutron Probe Data..... | 26 |
| ACKNOWLEDGMENT | 27 |
| REFERENCES | 27 |
| APPENDIX A--THERMISTOR CALIBRATIONS | 28 |
| APPENDIX B--VZMS GEOLOGIC LOGS | 29 |
| APPENDIX C--SOIL GAS ANALYSIS | 34 |
| APPENDIX D--SOIL SAMPLE PHYSICAL PROPERTIES | 35 |

LIST OF TABLES

| | |
|---|----|
| Table 1. Nominal Resistance versus Temperature Curve for Thermistor | 11 |
| Table 2. VOC Concentrations in VZMS-A. | 14 |
| Table 3. VOC Concentrations in VZMS-B. | 15 |
| Table 4. Results of Particle Size Analyses for VZMS-A and VZMS-B. | 23 |

LIST OF FIGURES

| | |
|---|----|
| Figure 1. Schematic drawing of VZMS cluster..... | 5 |
| Figure 2. Vertical profile schematic illustrating VZMS cluster layout in a borehole. | 6 |
| Figure 3. Tensiometer fabrication layout..... | 8 |
| Figure 4. Suction lysimeter fabrication layout..... | 9 |
| Figure 5. Soil gas probe fabrication layout. | 10 |
| Figure 6. VOC concentrations for compounds with concentrations less than 1000 ppbv in VZMS-A..... | 16 |
| Figure 7. VOC concentrations for compounds with concentrations greater than 1000 ppbv in VZMS-A..... | 16 |
| Figure 8. VOC concentrations for compounds with concentrations less than 1000 ppbv in VZMS-B..... | 17 |
| Figure 9. VOC concentrations for compounds with concentrations greater than 1000 ppbv in VZMS-B..... | 17 |
| Figure 10. Total halogenated and aromatic hydrocarbons in VZMS-A..... | 18 |
| Figure 11. Total halogenated and aromatic hydrocarbons in VZMS-B..... | 18 |
| Figure 12. VZMS instrumentation log..... | 20 |
| Figure 13. Surface completion of VZMS | 22 |
| Figure 14. Sand, silt, and clay distributions in VZMS-A. | 24 |
| Figure 15. Sand, silt, and clay distributions in VZMS-B. | 25 |
| Figure 16. VZMS-NP-2 neutron probe and relative lithologic log..... | 26 |

ABSTRACT

Two vadose zone monitoring systems (VZMS) have been installed at Site S-7, in Investigation Cluster 34 (IC 34), in Operable Unit A (OU A) of McClellan AFB. The two boreholes, VZMS-A and VZMS-B were instrumented at depths ranging from approximately 6 ft to 113 ft. Instruments were installed in clusters using a custom-made stainless steel cage with a spring-loaded mechanism allowing instruments to be in contact with the well bore wall once in place. Each cluster contains a tensiometer, suction lysimeter, soil gas probe and thermistor for measuring hydraulic potential, liquid- and gas-phase pressure, temperature of the formation and for collecting samples for chemical analyses in both the liquid and gas phases. Neutron probe logging is performed in two separate, smaller borings, VZMS-NP-1 and VZMS-NP-2, to obtain soil moisture content data. Preliminary details of soil gas analyses, laboratory field testing of soil samples, particle size analyses and neutron probe data are presented.

1.0 INTRODUCTION

1.1 Project Description

Lawrence Berkeley National Laboratory (LBNL), with assistance from Radian Corp. ("Radian") and Water Development Inc. ("drillers") completed, in December of 1995, the subsurface installation of two vadose zone monitoring systems (VZMS) for the purpose of measuring the concentrations and fluxes of volatile organic compounds (VOCs). This installation took place at Site S-7, in Investigation Cluster 34 (IC 34), in Operable Unit A (OU A) of McClellan AFB. These monitoring systems provide a unique opportunity to simultaneously, and over time, measure both dissolved and gaseous phase VOCs as well as their vertical gradients, thereby producing a comprehensive data set for model validation. The underlying rationale for this work is the need for the validation of vadose zone transport modeling.

1.2 Site Description

Site S-7 is the former location of the Industrial Wastewater Treatment Plant (IWTP) #3 and water cooling ponds. The IWTP #3 consisted of a free oil separator, an oil sump, a clarifying tank, an air-saturation tank, a flotation tank, holding tanks, a bleed-off tank, two sand filters, and an underground holding tank. All piping between tanks was below grade. All IWTP #3 structures were removed in 1981. Since that time, the location has been used as a storage facility for generator and plumbing supplies. It is completely paved.

Previous investigations, which included the drilling of 16 soil borings and the sampling and analysis of soil and soil gas, identified the presence of a number of contaminants. Soil contaminants included benzene, chlorobenzene, ethylbenzene, toluene, xylene, methyl isobutyl ketone, 1,1,2,2-tetrachloroethane, oil and grease, acenaphthene and phenanthrene. Contaminants found in soil gas were benzene, toluene, xylenes, total volatile hydrocarbons, cis-1,2-DCE, TCE, and trans-1,2-DCE (McLaren, 1986; Jacobs, 1995). A single groundwater sample (well SS7HP46) contained 13 µg/L TCE.

1.3 Geology

Previous investigations have shown the site to be underlain by interbedded poorly-graded sand and silt layers, with thin and sparse gravel and clay layers. Apparently continuous, 5 to 10 ft thick layers of sand are found between 20 and 30 ft below ground surface (bgs), 40 and 60 ft bgs, and

60 and 80 ft bgs. The interval from the surface to 25 ft bgs is dominated by silt. The depth to groundwater, as encountered in boring SS7HP46, is 110 ft bgs.

2.0 VZMS DESIGN

2.1 General Design

The Vadose Zone Monitoring System (VZMS) is an array of instruments used to monitor water flow in unsaturated soils. The array has been developed to allow its emplacement down a borehole to form a monitoring nest consisting of several sets of instruments arranged vertically along the borehole. VZMS is an integration of technologies for assessing soil hydraulic potential, moisture content, liquid- and gas-phase pressure, and temperature of the formation, as well as the concentrations of contaminants in both liquid and gas phases. Instruments are placed in clusters (Figure 1) and installed at the desired depth as illustrated in Figure 2. The cluster includes a stainless-steel, spring-loaded mechanism which, when triggered, pushes the instruments against the borehole wall in order to enhance contact between the sensor and the formation. Those instruments which rely on the exchange of fluids between the formation and the sensor have backfill sacks, which are described in a subsequent section. All parts of the instruments which might be in contact with contaminated water or gas were made of stainless steel.

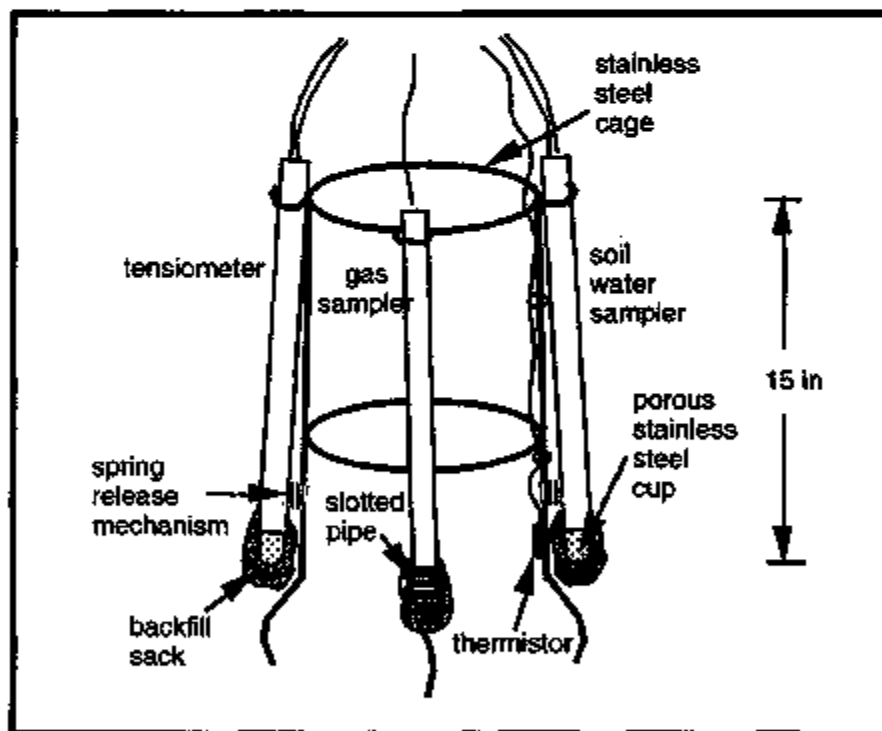

Figure 1. Schematic drawing of VZMS cluster.

Each level of the vadose zone monitoring system (VZMS) is instrumented to provide the following types of measurements:

- Hydraulic potential measurements:
 - Tensiometer

- Soil solution sampling:
 - Suction lysimeter
- Soil gas sampling and gas pressure measurements:
 - Soil gas sampling port
- Temperature measurements:
 - Thermistors

Each level of instrumentation is backfilled with sand and then separated from underlying and overlying levels with a layer of bentonite. Neutron logging for moisture content measurement is performed in separate, smaller boreholes. The description of individual instruments follows.

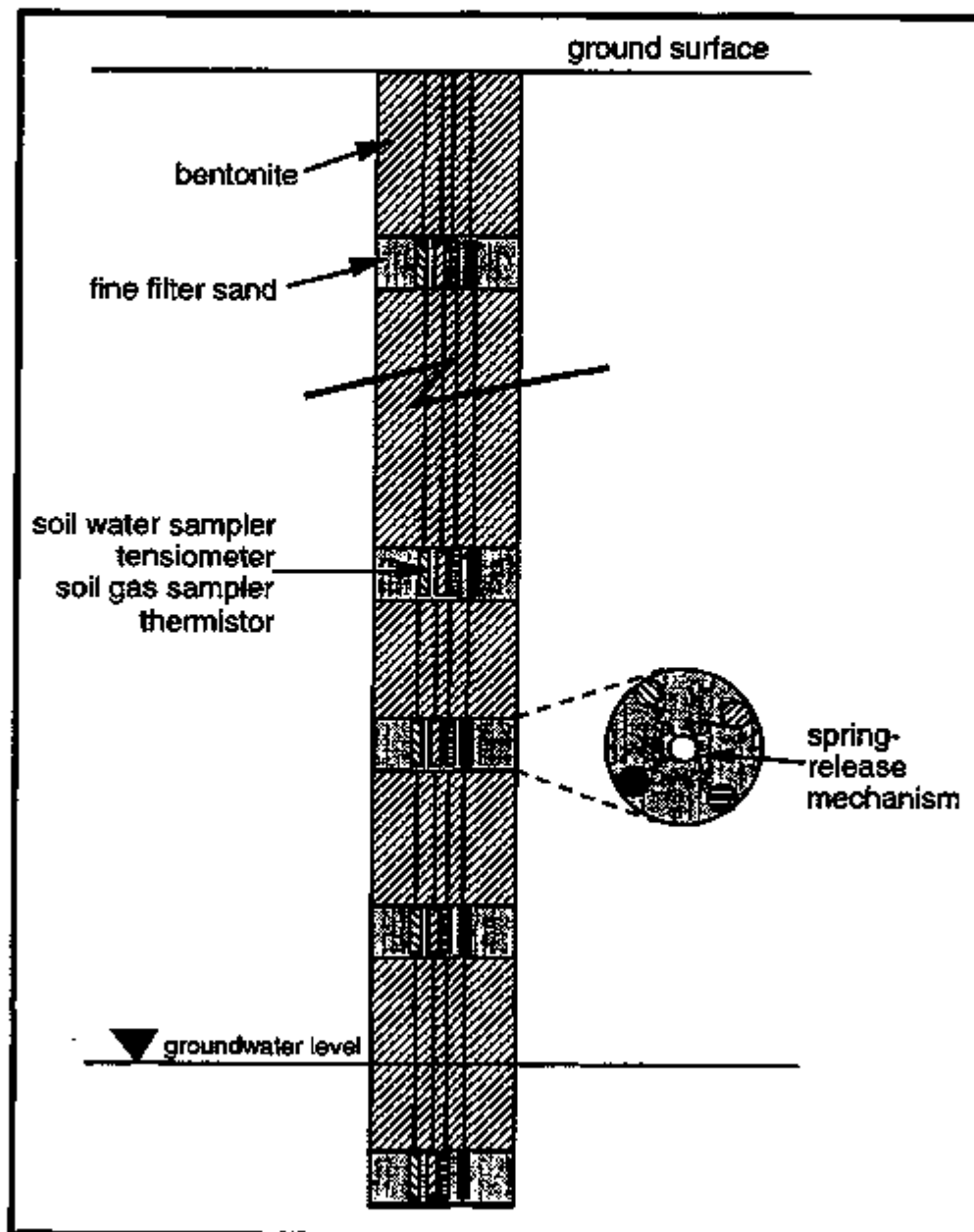

Figure 2. Vertical profile schematic illustrating VZMS cluster layout in a borehole.

2.2 Instrument Design

The instruments used in this installation were custom-made at LBNL. Among the goals of this design were the collection of representative samples for chemical analysis, miniaturization of instruments to fit in a relatively narrow borehole, and integration to allow easy deployment.

2.2.1 Tensiometer

The tensiometer provides a means of measuring soil water pressures that may be either negative (unsaturated zone) or positive (saturated zone). Conventional tensiometers with water filled tubes can not be used at depths greater than 5 to 7 m. The disadvantage of conventional tensiometers is that the water level in the water-filled tube of the tensiometer is uncontrollable, which may increase its response time and disturb the equilibrium of the "soil-tensiometer" system. We have installed a new design of air-pocket tensiometer in which a porous tip is connected to a two-cell transducer with a constant water level above the porous tip (Faybishenko, 1996). This type of tensiometer has been used for monitoring water movement in the vadose zone at many field sites in the former Soviet Union (Faybishenko, 1986), and has been tested and used to monitor hydraulic pressure in fractured unsaturated-saturated basalt at the Box Canyon site of the Idaho National Engineering Laboratory. For this project, all parts of the tensiometer were custom made in order to fit the tensiometer into a borehole monitoring cluster.

The tensiometer consists of three parts: (1) a porous tip of cylindrical shape, (2) a two-cell transducer, and (3) a module consisting of three air-filled tubes that provide a means for measurements and maintenance. The porous tip was fabricated from a stainless steel porous tube [distributed by Newmet Krebsoge, Terryville, CT]. The fabrication layout of the tensiometer is shown in Figure 3.

The porous tip is filled with water and connected through a coupling to the two-cell transducer. The transducer, an essential component of the tensiometer, is designed to maintain an essentially constant water level above the ceramic tip. This is accomplished by constructing the transducer with a lower and upper cell. These cells are separated by a concentric ring-plate with an opening at the center. A short tube located in the lower cell is fixed to the opening in the plate and provides a means of controlling the water level in the lower cell. Such a design creates a confined air pocket in the top portion of the lower cell. The upper cell serves as a reservoir to recharge the lower cell with water as needed.

The connecting tubes provide a means of measuring pressure and replenishing water to the transducer as needed. One of the tubes connects the top point of the upper cell and allows measurement of the air pressure in the upper cell. The second tube is terminated 1-2 cm beneath the top of the upper cell and is used to add or withdraw water from the tensiometer. The third tube connects to the top point of the lower cell, providing access to and measurement of the air pressure in the lower cell. The tubes at the top of the lower and upper cells are connected to pressure transducers and a computerized data acquisition system. To accelerate the process of equilibrating the tensiometer with the soil, an initial vacuum can be applied to the tensiometer. The direction in which the pressure is trending is then observed in the field and the vacuum can be modified accordingly. During installation, the porous tip of the tensiometer is enclosed in a bag filled with silica sand, called a backfill sack.

Deep Well Tensiometer

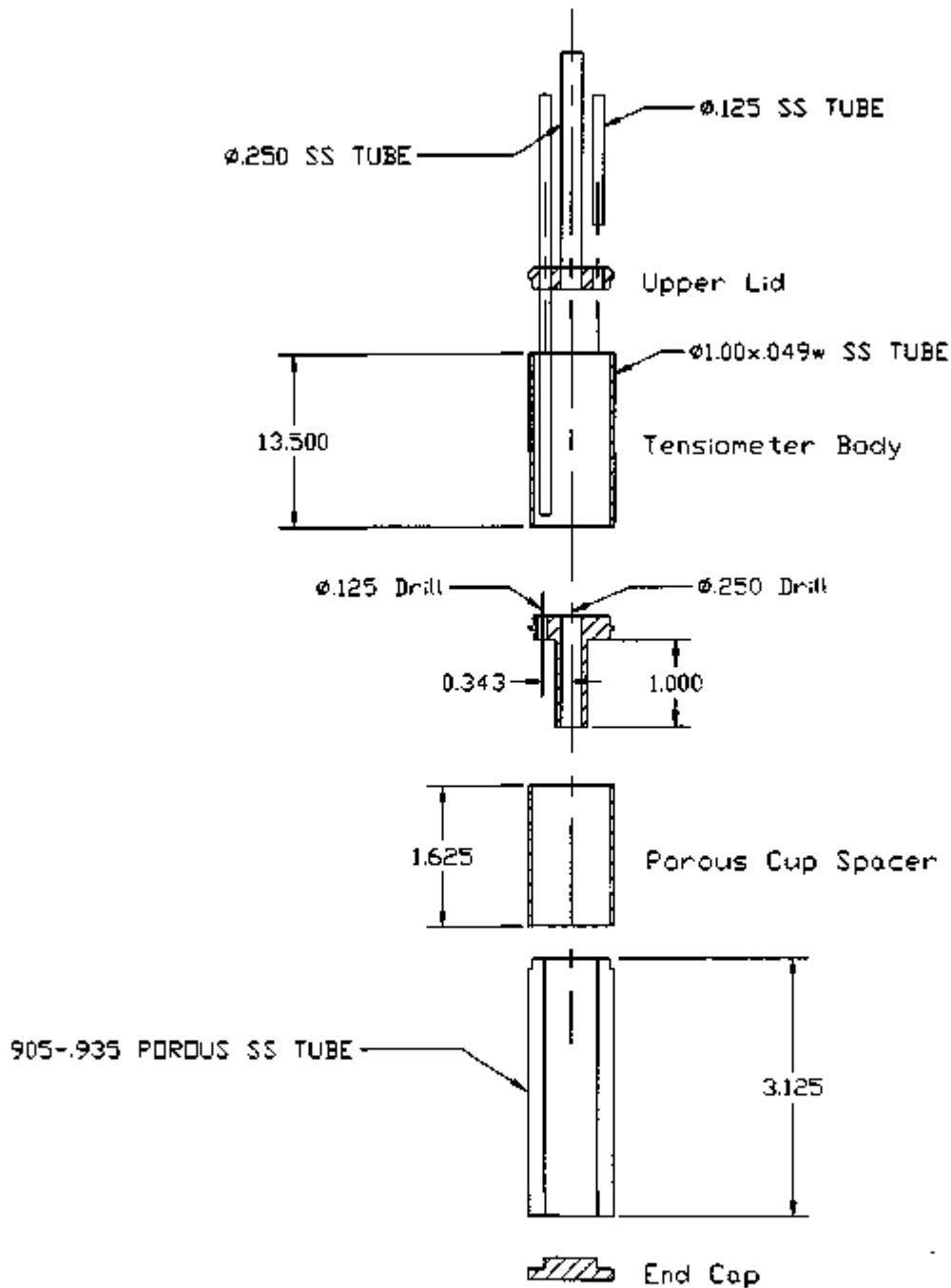

All material: Type 304SS. Use only water soluble cutting fluids.

Figure 3. Tensiometer fabrication layout.

2.2.2 Suction Lysimeter

The suction lysimeter is a two chamber design used for sampling at depths greater than 7-8 m. The fabrication layout of the suction lysimeter design is shown in Figure 4. Two 1/8 in tubes connect the lysimeter to the surface. One tube is used for the introduction of a purge gas and the other line allows the sample collected to be transported to the surface. A miniature check valve separates the lower chamber from the upper chamber. A 0.5µm porous stainless steel cylinder permits the collection of the sample which is drawn by vacuum through the check valve into the upper chamber.

The porous end of the suction lysimeter is enclosed in a nylon backfill sack. To withdraw a water sample from the soils into the suction lysimeter, a vacuum is applied to the tube connected to the top of the upper chamber. In order to bring the water sample to the surface, dry gas, either N₂ or clean air, is used to pressurize the upper chamber, forcing the water sample up through the second tube that connects the bottom of the upper chamber to ground surface. The check valve closes, preventing liquid from being forced back into the lower chamber.

Suction Lysimeter

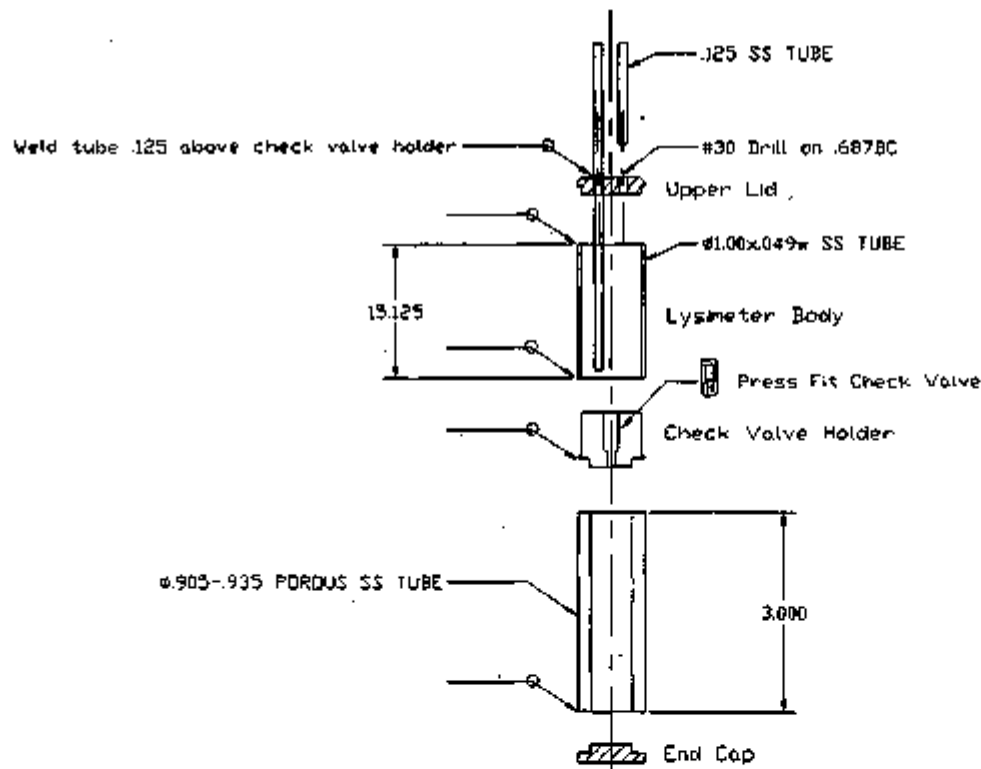

All material: Type 304SS. Use only water soluble cutting fluids. Perform lower lysimeter body weld prior to installing check valve.

Figure 4. Suction lysimeter fabrication layout.

2.2.3 Soil Gas Probe

The soil gas probe, shown in Figure 5, consists of a 7.62 cm long, 100 μm porous metal cylinder with welded top and bottom flanges. A 1/4 in diameter stainless steel tube extends out from the top flange and is connected using Swagelok® compression fittings to a 1/4 in Teflon tube that goes up to the ground surface. A Swagelok® plug with a silicon septum stopper is used to seal the Teflon line. In order to purge the gas collected in the gas probe, the PID-580 is used. A gas sample is then taken by applying a vacuum through an absorbent tube. EPA TO14 analyses will be performed by the Environmental Measurements Laboratory of LBNL.

Soil Gas Sampler

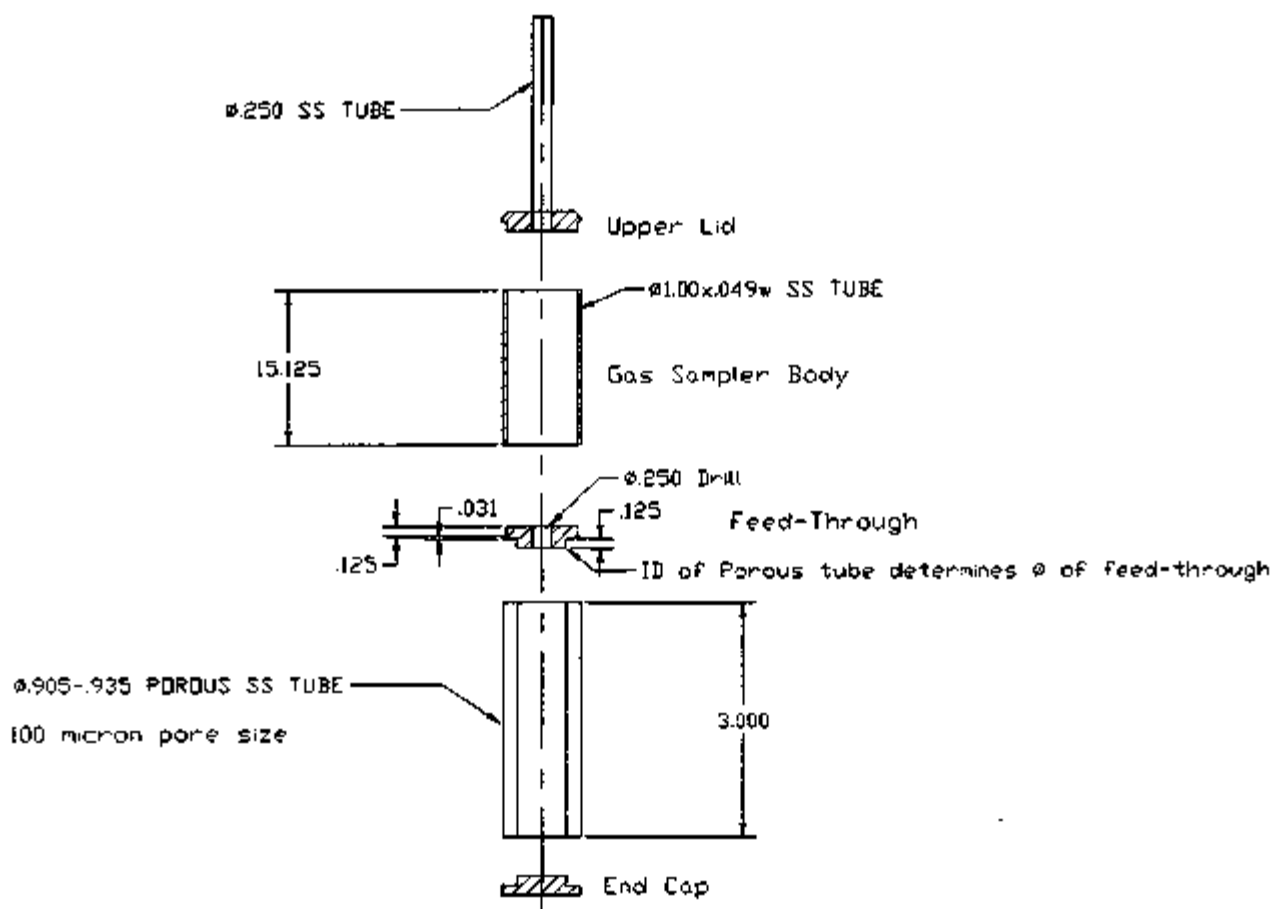

All material: Type 304SS. Use only water soluble cutting fluids.

Figure 5. Soil gas probe fabrication layout.

2.2.4 Thermistor

Thermistors are thermally sensitive resistors which exhibit a change in electrical resistance with a change in temperature. The thermistors used in this system (NTC-DC95, Thermometrics, New Jersey) are ceramic semiconductors with a negative temperature coefficient of resistance, i.e. resistance readings decrease with increasing temperature. These bead-shaped thermistors have Pt-alloy leadwires, directly centered into a ceramic body. The standard resistance for the thermochip at 25°C is 10,000 Ω. The unit is accurate to within ±0.1°C within the range 0°C to 70°C when using the standard resistance ratio curve. Data to generate the nominal curve for this thermistor are shown in Table 1. Due to the high resistance of the thermochip, the resistance measurement can be taken in a two-wire configuration with less than 0.05% error due to leadwire length.

Each thermistor was soldered onto a 100-ft-long Belden #8451 twisted and shielded 22AWG instrumentation cable. To protect the thermistor from mechanical stress, each bead was housed in a stainless-steel shield. To prevent moisture from seeping into the leadwires, each wire was shrink-wrapped and then insulated with epoxy.

Calibration of each thermistor was done in the laboratory, using the procedure recommended by the manufacturer. The Steinhart and Hart equation was used:

$$\frac{1}{T} = a + b(\ln R) + c(\ln R)^3 \quad (1)$$

where R is resistance in ohms and a , b , and c are coefficients derived from measurement. For this set of thermistors, the average values for a , b , and c are 1.1×10^{-3} , 2.35×10^{-4} , and 9.56×10^{-8} , respectively. The complete table of calibration coefficients can be found in Appendix A.

Table 1. Nominal Resistance versus Temperature Curve for Thermistor

| Temperature °C | R/R_{25} °C |
|----------------|---------------|
| 0 | 3.2651 |
| 5 | 2.5391 |
| 10 | 1.9898 |
| 15 | 1.5710 |
| 20 | 1.2492 |
| 25 | 1.0000 |
| 30 | 0.8057 |
| 35 | 0.6531 |
| 40 | 0.5327 |
| 45 | 0.4369 |
| 50 | 0.3603 |
| 55 | 0.29886 |
| 60 | 0.24882 |
| 65 | 0.20828 |
| 70 | 0.17517 |

2.2.5 Neutron Probe

Relative measurements of soil moisture content are made using a downhole neutron probe. Neutron probe measurements are based on the principle of neutron thermalization during collisions with hydrogen atoms. "Fast" neutrons are emitted by the probe into the formation. A detector in the probe counts the "slow" neutrons produced by these collisions. The number of "slow" neutrons is proportional to the moisture content of the surrounding medium. In conjunction with tensiometer data, neutron probe measurements help define movement of water in the subsurface. The neutron source required for a measurement with an effective radius of 15 cm is of sufficiently low strength that it poses an insignificant health hazard when properly used. The probe used in this system (CPN 503DR Hydroprobe) consists of a 50 mCi Am-Be neutron source which emits 1.1×10^7 neutrons per second and a He detector of thermal neutrons. When high energy neutrons are emitted into the rock or sediment formation, they are "slowed down" or "thermalized" when they collide with hydrogen nuclei. The slow or thermal neutrons are detected and their count is proportional to the hydrogen concentration in the formation. Since water is by far the main source of hydrogen in this setting, the count is proportional to the moisture content. Although many calibrations exist for converting counts to moisture content, conversion is always highly formation- and well-completion-specific. Therefore, the counts, or ratio of counts to some standard count, are most reliably used in the determination of relative moisture content changes.

The neutron probe logging is performed in separate access boreholes adjacent to the VZMS installations. Two additional borings, VZMS-NP-1 and VZMS-NP-2, 4 in in diameter, each 100 ft deep, were constructed with 2-in PVC casing grouted in place. The casing provides a continuous sheath through which the probe is lowered. Readings are taken at selected depth intervals, usually on the order of 1 to 2 ft.

3.0 VZMS INSTALLATION

Instrument installation took place between 12/13/95 and 12/21/95. Drilling services were provided by Water Development Inc. and geologic logging and soil-gas sample collection were provided by Radian personnel.

3.1 Drilling and Sampling

Standard hollow-stem drilling, coring and sampling methods were used during the installation. Two vertical borings were drilled to 115 ft using an 10 in OD hollow-stem auger. The boreholes were then reamed with a 12 in OD auger. Installation of nested instruments occurred in these two boreholes, through the 12 in OD auger. Continuous samples were taken using a Modified California split-spoon sampler and logged in the field by field geologists from Radian and LBNL. Each borehole was drilled to approximately 2 ft below the water table. Out of concern for borehole collapse, the auger stem was gradually raised as the instruments were installed through the auger stem.

Soil samples not slated for physical or TOC analyses were placed in wax-impregnated cardboard core-boxes, labeled, and described by the method in ASTM D 2487-90. Selected soil samples for TOC analysis and physical parameter determination were sent to BSK & Assoc. laboratory. Samples were capped and sealed to preserve moisture content. Soil gas samples were collected in canisters at approximately 10-ft depth intervals and were submitted for TO-14 analysis (Air Toxics Ltd.).

Two additional vertical 4-in borings were drilled using a solid-stem auger for the purpose of neutron probe access pipe installation. These were drilled to the water table. The neutron probe borings were not sampled because a larger boring would have been required and in turn would have resulted in a larger annulus of backfill and a reduced effective radius of penetration into the formation for neutron logging.

Augers, drill bits, and split-spoon samplers were steam-cleaned prior to drilling and in between boreholes. In addition, split-spoon samplers and brass sleeves were rinsed with distilled water immediately before sampling.

3.2 Criteria for Instrument Location

Geologic information from sampled cores and soil-gas analysis results were used in the selection of depth intervals at which instruments were installed. The primary criterion was to capture data from all or most of the lithologic units of notable thickness. Another criterion was to ensure that each cluster was placed entirely within a single lithologic unit. The sections below summarize the geologic logs and soil-gas analyses. The complete results can be found in Appendices B and C.

3.2.1 Lithology

Although the lithologic sequences in the two 8-in boreholes differed in detail, in general they consisted of interlayered silts and sands, with occasional layers of coarse sand, especially toward the bottom of the profile. These layers were generally 5 to 10 ft thick. Core recovery was high, approximately 90 to 100% in most cases and provided an almost continuous record. No samples were taken below 100 ft but the cuttings indicated sandy sediment.

The most significant feature of the sequence was the predominance of sandy silt in the top 30 ft of borehole VZMS-A and the top 20 ft of VZMS-B. Sands dominate both profiles below 60 ft, with a coarse sand layer in both boreholes between 61 and 66 ft, again around 72 ft, and once more below 93-95 ft. Little moisture was observed, with most samples characterized as dry to damp.

3.2.2 Soil-Gas Analysis

Twenty soil-gas samples, ten from each borehole, were collected during the drilling operation. At any given sampling depth, a drive point connected to a Teflon tube was driven into the soils at the bottom of the borehole. Before sampling, a gas volume equal to three times the volume of the connecting tube was purged from the line. A gas sample was then taken in a SUMMA canister.

Gas samples were analyzed for VOCs using the TO-14 method. The results are summarized in Tables 2 and 3, and Figures 6 through 11 and listed in entirety in Appendix C. Blank spaces in the tables indicate non-detection. In both boreholes, VOC concentrations declined to depths of 40 to 50 ft. TCE, and cis-1,2-DCE are the dominant contaminants, with TCE as high as 38,000 ppbv (VZMS-A, 10 ft) and cis-1,2-DCE as high as 8,200 ppbv (VZMS-B, 20 ft). The details of VOC distributions are conspicuously different from borehole to borehole. For example, a significant relative low in overall aromatic concentrations observed at 40 ft in VZMS-A is contrasted by a high in VZMS-B. Furthermore, some compounds were observed in only one of the two boreholes (e.g. ethyl benzene). It is anticipated that samples collected from permanently installed gas probes will be more representative of actual concentrations in the formation.

Table 2. VOC Concentrations in VZMS-A.

| VZMS-A | | | | | | | | | | |
|----------------------------|----------------|--------------|---------|-------------|------------|---------|---------|-------|---------------|---------|
| VOC Concentrations in ppbv | | | | | | | | | | |
| Depth (ft) | Vinyl Chloride | Methylene Cl | 1,1-DCE | cis-1,2-DCE | Chloroform | Benzene | 1,2-DCA | TCE | Chlorobenzene | Toluene |
| 10 | 270 | 91 | | 37000 | | 100 | 160 | 38000 | | |
| 20 | 27 | 45 | | 2300 | | | 92 | 4400 | | |
| 30 | 5.2 | 12 | 6.7 | 560 | 4.3 | | 46 | 940 | | 7.2 |
| 40 | | | | | | | | | | |
| 50 | | 5.3 | | 24 | | 6.8 | 4.6 | 33 | | 5.3 |
| 60 | | | | 36 | | 4.4 | 6.3 | 28 | | 5.5 |
| 70 | | 67 | 4.8 | 150 | 6 | 4.4 | 30 | 120 | | |
| 80 | | 45 | 12 | 220 | | 14 | 11 | 390 | 10 | |
| 90 | | | | | | | | | | |
| 100 | | | | | | | | 11 | | 5.1 |

| Depth (ft) | Ethylbenzene | PCE | Xylene | 1,3,5-THB | 1,2,4-THB | 1,3-DCB | 1,4-DCB | 1,2-DCB | Propylene | Acetone |
|------------|--------------|------|--------|-----------|-----------|---------|---------|---------|-----------|---------|
| 10 | | | | | | 100 | 400 | 240 | 740 | |
| 20 | | | 920 | 1700 | 540 | 70 | 490 | 31 | 390 | 36 |
| 30 | | | 250 | 610 | 260 | 20 | 180 | 31 | 160 | 50 |
| 40 | | 6.85 | 8 | 20 | 9 | | 5.9 | | | 26.5 |
| 50 | | 30 | 5.8 | 10 | 7.8 | 4.7 | 32 | 140 | 140 | 43 |
| 60 | | | 28.1 | 76 | 29 | 5.2 | 39 | 44 | 33 | 34 |
| 70 | | | 5.1 | 12 | | 12 | 71 | 13 | 150 | 18 |
| 80 | | | | 17 | | | | | 160 | |
| 90 | | | | | | | | | 1200 | 10000 |
| 100 | | | | | | | | | 71 | 1200 |

Table 3. VOC Concentrations in VZMS-B.

| VZMS-B | | | | | | | | | | |
|----------------------------|----------------|-------------------|-------------|-----------------|-----------------|---------|-------------|------|--------------------|---------|
| VOC Concentrations in ppbv | | | | | | | | | | |
| Depth (ft) | Vinyl Chloride | Methy- lene Cl | 1,1- DCE | cis-1,2- DCE | Chloro- form | Benzene | 1,2- DCA | TCE | Chloro- benzene | Toluene |
| 10 | | | | 1500 | | | 12 | 2100 | | |
| 20 | | 80 | | 8200 | | 75 | 250 | 7500 | 66 | 61 |
| 30 | | 9.7 | 4.8 | 470 | | 5.9 | 41 | 500 | | 8.2 |
| 40 | | | | | | | | | | |
| 50 | | | | 300 | | 6.6 | 14 | 325 | | 7.55 |
| 60 | | 44 | | 160 | 4.1 | 20 | 35 | 100 | 4 | 27 |
| 70 | | | | | | | | | | |
| 80 | | 50 | 19 | 320 | 10 | 22 | | 750 | 83 | 11 |
| 90 | | 6.7 | | 65 | | 4.7 | | 83 | 5.4 | 5.6 |
| 100 | | | | 32 | | | | 38 | | 6.05 |

| Depth (ft) | Ethyl- benzene | PCE | Xylene | 1,3,5- THB | 1,2,4- THB | 1,3- DCB | 1,4- DCB | 1,2- DCB | Propy- lene | Acetone |
|------------|-------------------|-----|--------|---------------|---------------|-------------|-------------|-------------|----------------|---------|
| 10 | | | | | | 31 | 23 | | | 28 |
| 20 | 67 | | 390 | 390 | | 180 | 1000 | 290 | | 350 |
| 30 | | | 25 | 23 | | 22 | 140 | 20 | | 48 |
| 40 | | | | 25 | | 15 | 91 | 25 | 610 | 7400 |
| 50 | | | 12.22 | 7.2 | | 6.95 | 32.5 | 12.5 | | 144.5 |
| 60 | 4.7 | | 15.9 | 12 | 8.3 | 18 | 140 | 17 | | 65 |
| 70 | | | | | | | 6.7 | | | 29 |
| 80 | | | 8 | 5.1 | 4.2 | 7 | 28 | 28 | | 54 |
| 90 | | | | | 4 | | 6.6 | 8.8 | | 46 |
| 100 | | | | | | | | | | 600 |

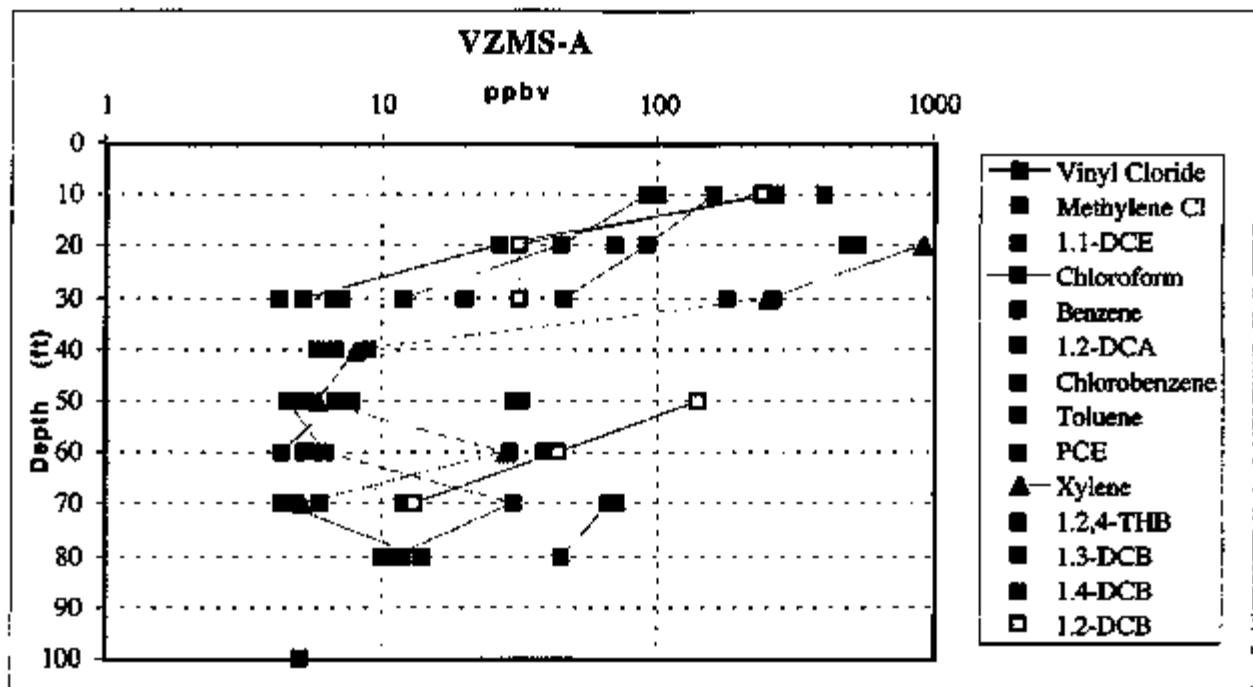

Figure 6. VOC concentrations for compounds with concentrations less than 1000 ppbv in VZMS-A.

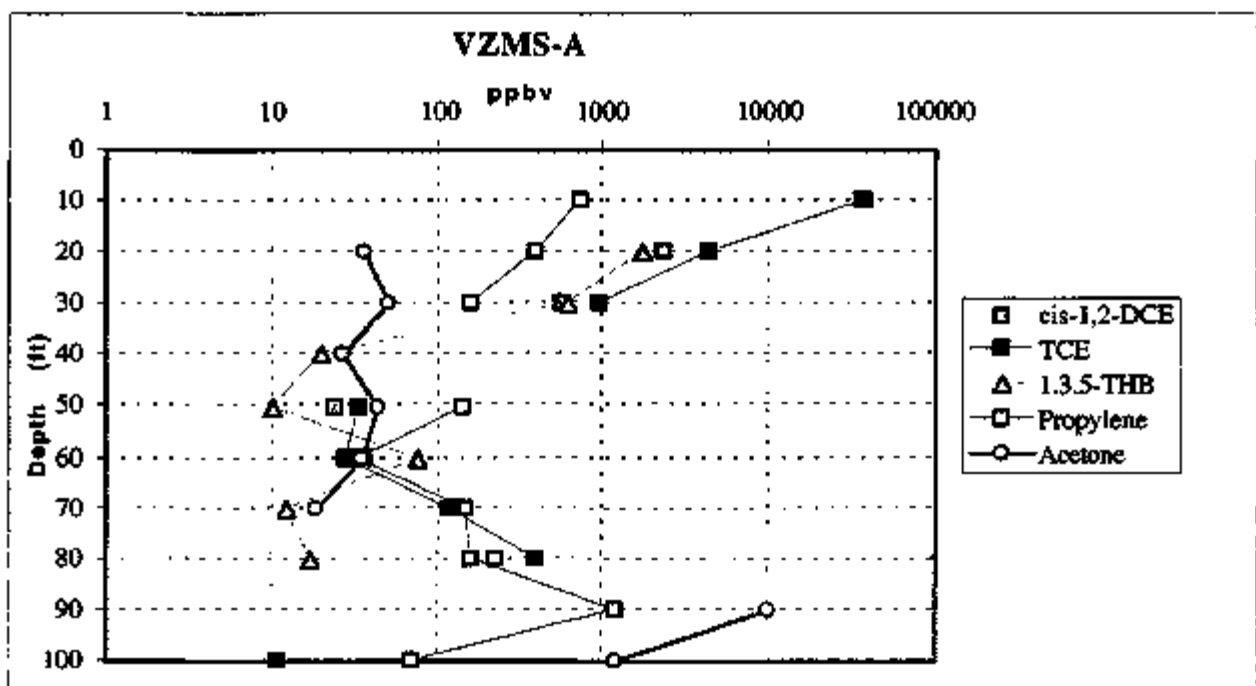

Figure 7. VOC concentrations for compounds with concentrations greater than 1000 ppbv in VZMS-A.

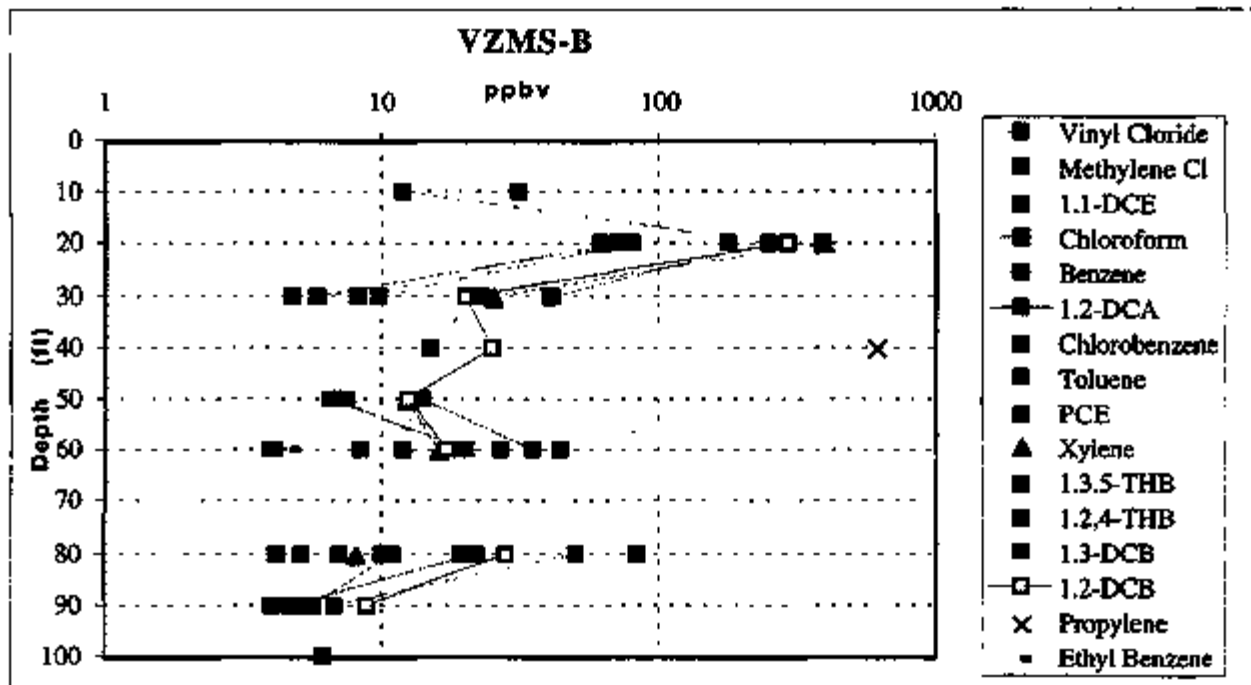

Figure 8. VOC concentrations for compounds with concentrations less than 1000 ppbv in VZMS-B.

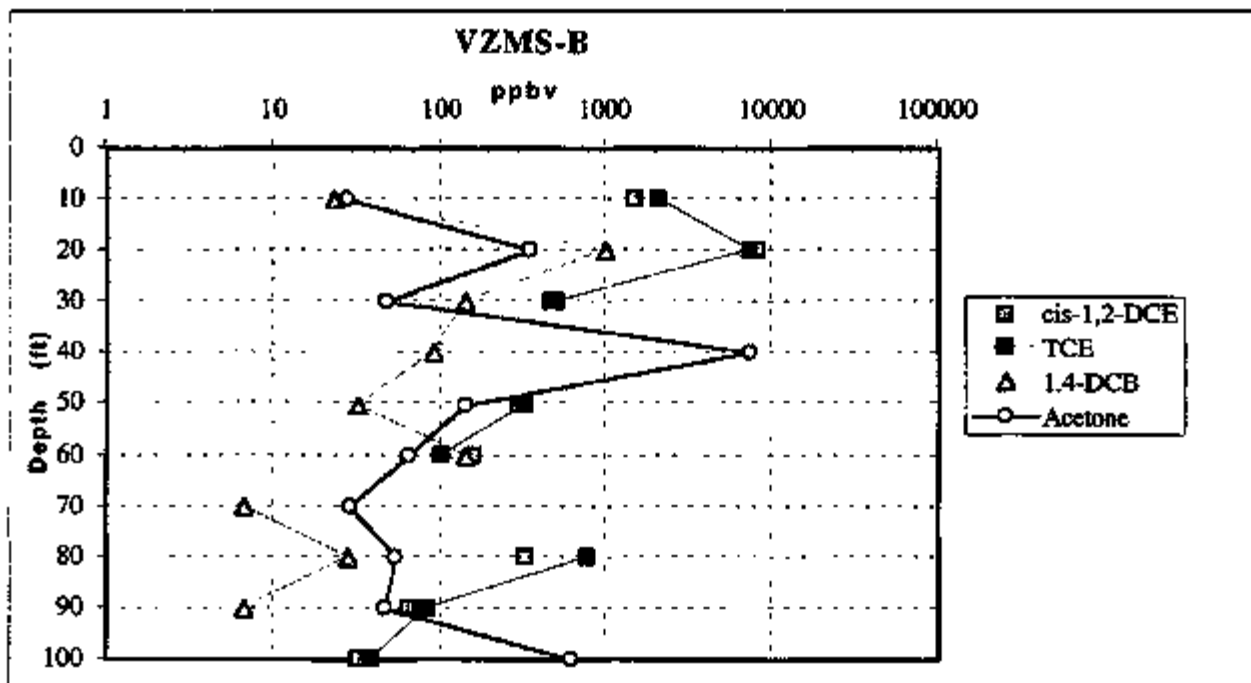

Figure 9. VOC concentrations for compounds with concentrations greater than 1000 ppbv in VZMS-B.

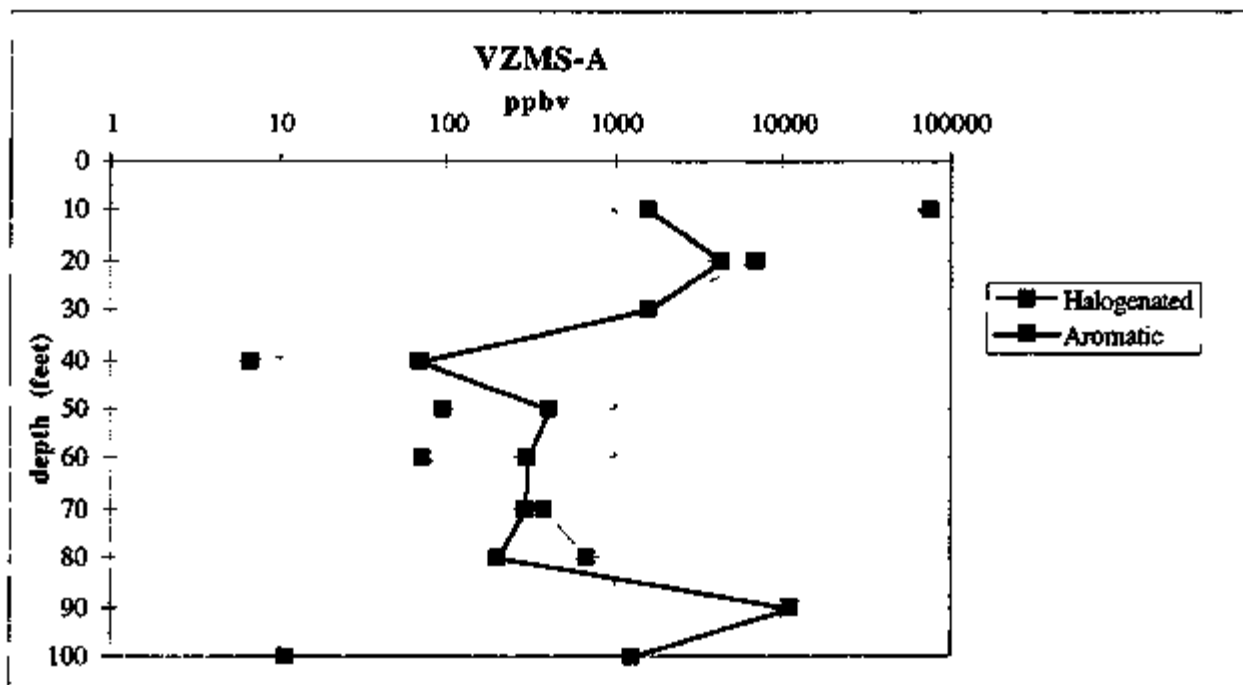

Figure 10. Total halogenated and aromatic hydrocarbons in VZMS-A.

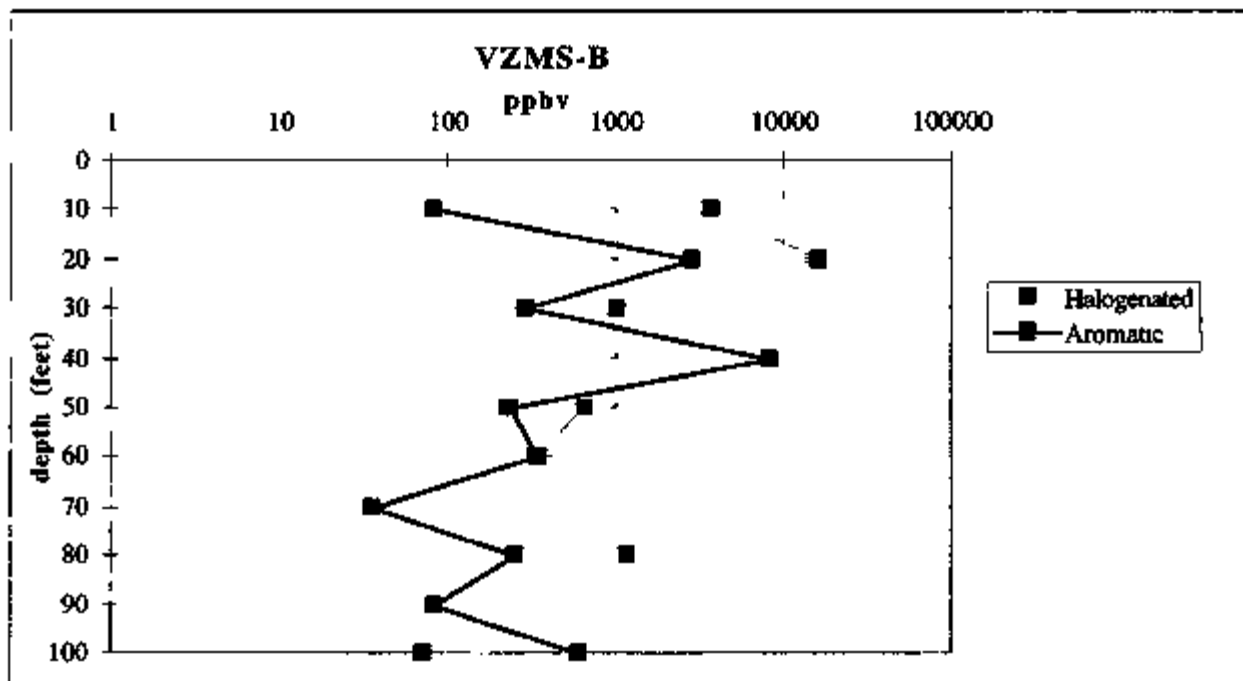

Figure 11. Total halogenated and aromatic hydrocarbons in VZMS-B.

3.3 VZMS Instrument Installation Procedures

A schematic construction log of the VZMS instrumentation is shown in Figure 12. The generalized lithology shown in Figure 12 is given in detail in Appendix B. Soil descriptor codes include SW (well-sorted sand), SP (poorly-sorted sand), SM (silty sand), SC (clayey sand), and ML (silt). Instruments installed at a single depth were arranged in clusters prior to installation. The spring-release mechanism which was used to press instruments against the borehole wall was set up in the "closed" position and hooked up to a nylon string which was later used to "open up" the springs. Each instrumentation level was underlain by at least 1 ft of bentonite which was poured through an auger and was saturated with water. Care was taken to introduce only enough water to saturate the bentonite without excessively wetting the borehole. On top of the bentonite, a 0.5 ft layer of fine sand was set. Subsequently the instrument cluster was lowered down the borehole, after which the springs were released. More fine sand was poured to cover all sensors, approximately a 1 ft thickness. All intervals between instrument clusters were backfilled with coarse bentonite and saturated with water. After the top-most level of instrumentation was installed, a cement grout slurry was poured to a depth of 2 ft below land surface. A flush-mounted utility vault was installed and will be used for access during water and gas sampling.

The neutron probe access pipes were installed after the solid-stem auger used in drilling operations was pulled out of the hole. A 2-in, Sch. 40 PVC pipe was installed down to a depth of 100 ft and grouted in with a cement slurry. A flush-mounted water-tight utility vault was installed at ground surface.

3.4 Surface Completion

Tube bundles from the nested instruments are terminated below the ground surface in Christy boxes covered with steel plates. Figure 13 shows the dimensions of the Christy boxes. Four inch PVC conduit connects to a side access port of the Christy box and comes through the concrete pad.

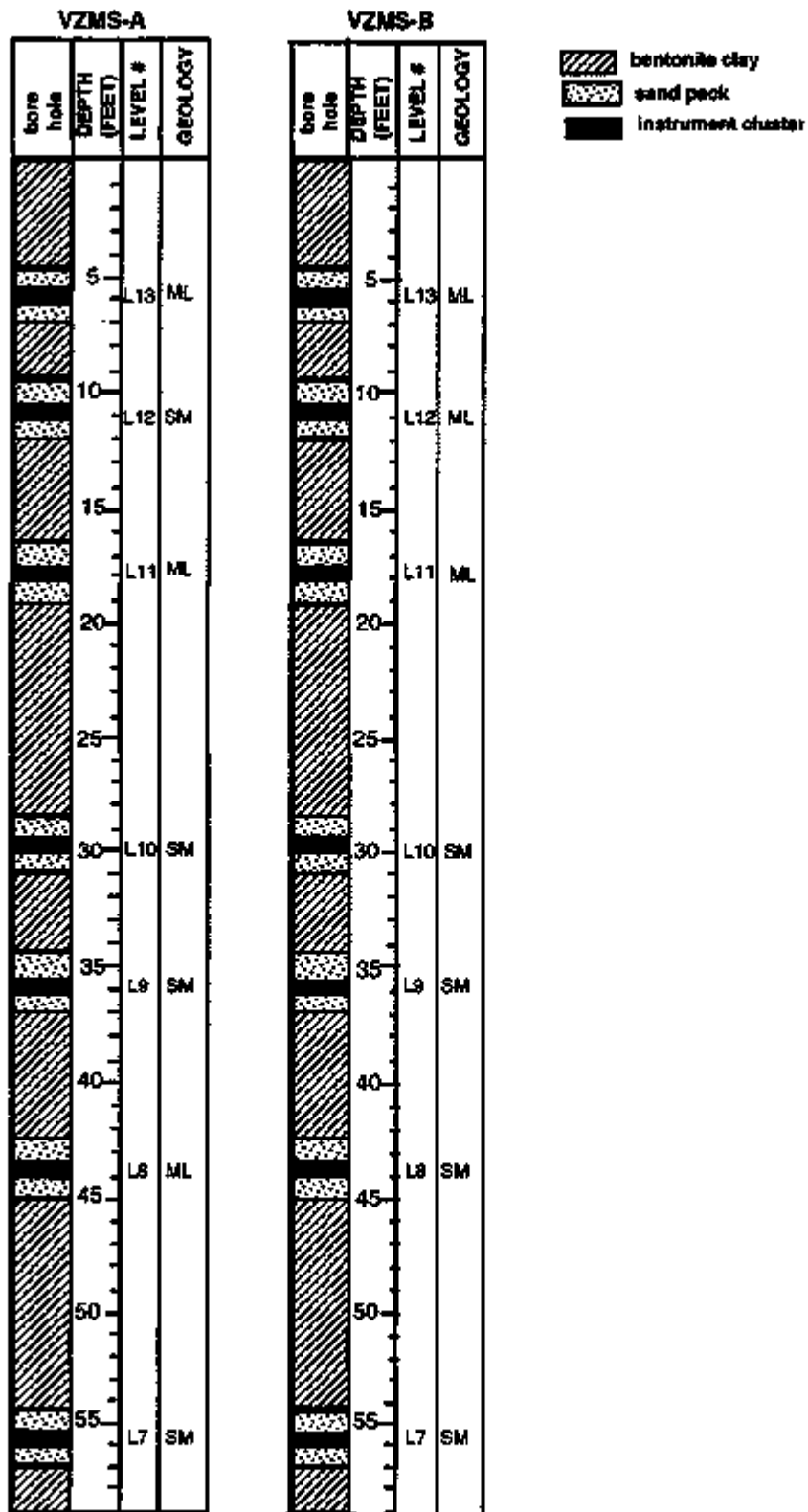

Figure 12. VZMS instrumentation log.

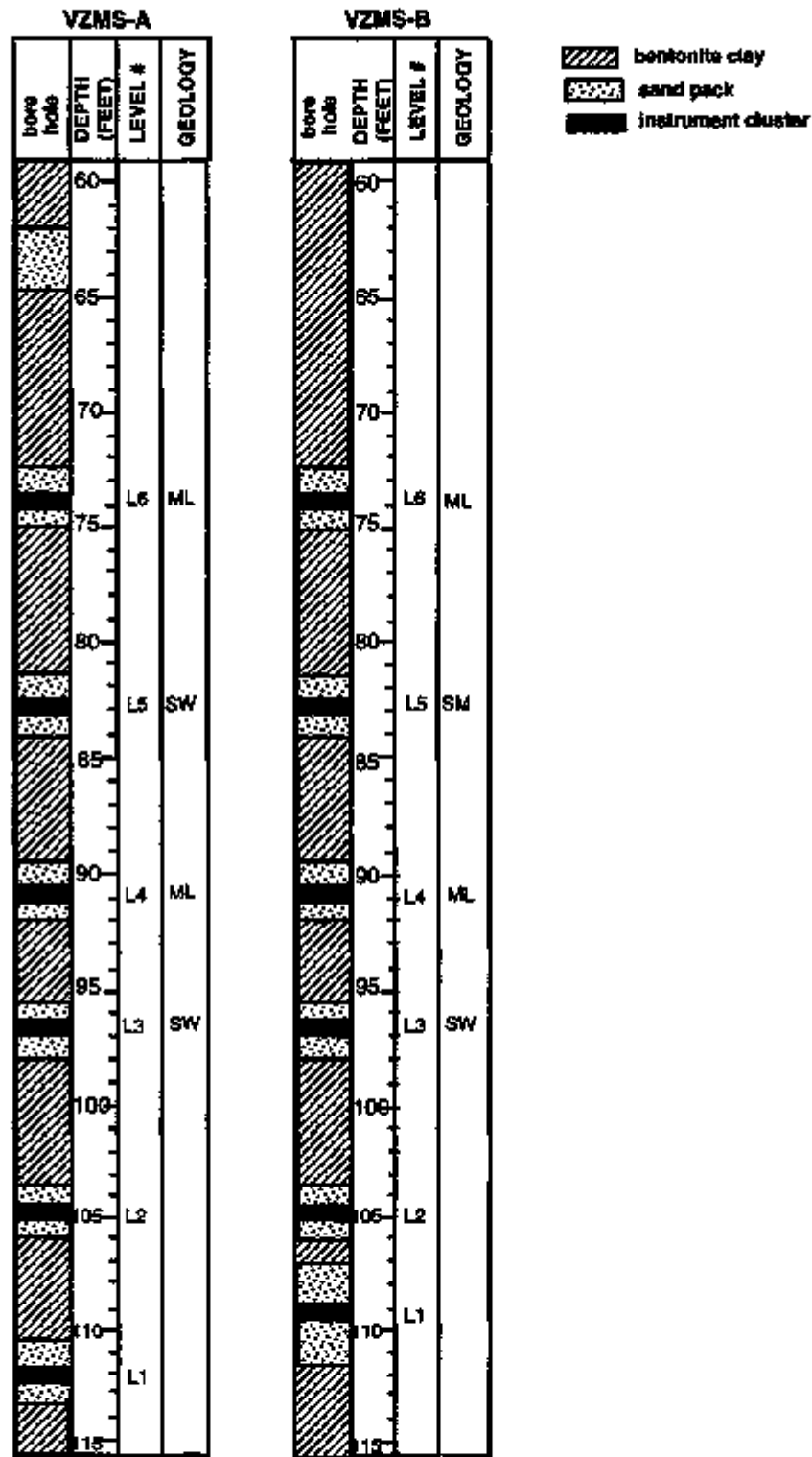

Figure 12. continued.

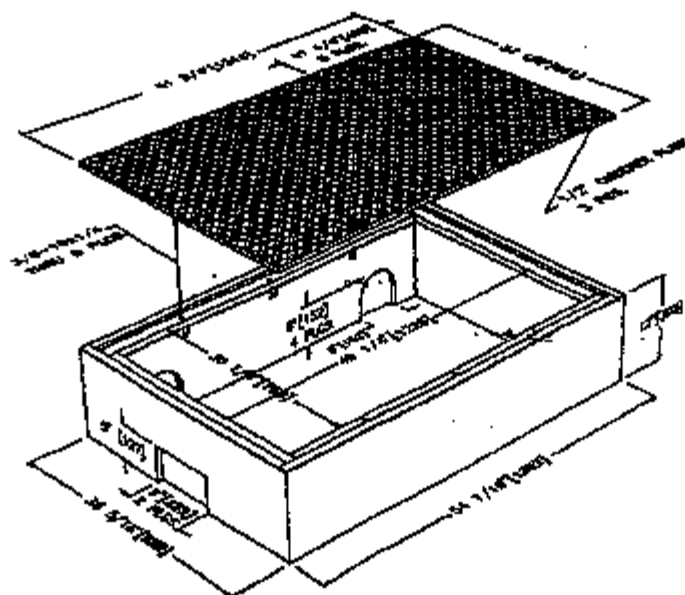

Figure 13. Surface completion of VZMS

4.0 PRELIMINARY RESULTS

4.1 Laboratory Testing of Field Soil Samples

Twenty-two soil samples taken from VZMS-A and VZMS-B were submitted to BSK & Assoc. laboratory for TOC analysis and physical parameter determination. Soil samples were tested to determine bulk (wet) density, moisture content, specific gravity, porosity and total organic carbon. Moisture content of soil samples ranged in values from 6.0 to 41.4 %. Bulk density of samples ranged from 86.4 pcf (1384.0 kg/m³) to 121.4 pcf (1944.7 kg/m³). Porosity measurements ranged from 36.1 up to 59.9 %. Total organic carbon in samples ranged from non-detectable to 350 mg/kg. A complete report of laboratory testing results provided by BSK is included in Appendix D.

4.2 Particle Size Analyses

Particle size analyses were performed on the soil samples taken from VZMS-A and VZMS-B using hydrometer method in ASTM D 422-63. Results are provided in Table 4 and Figures 14 and 15. In VZMS-A, the percentages of sand, silt and clay for the samples taken from the field ranged from 22.5 to 100 %, 0 to 67 % and 1.7 to 12.8 %, respectively. In VZMS-B, similar ranges of 36 to 99 %, 0 to 60.4 % and 0.6 to 7.9 % described the sand, silt and clay content respectively.

Table 4. Results of Particle Size Analyses for VZMS-A and VZMS-B.

| Depth (ft.) | Class | SIEVE (%) | | | PSA (%) | | |
|----------------|-------|---------------------|------------------------|----------------------|---------|------|------|
| | | >2000 μm | 425-2000 μm | 75-425 μm | sand | silt | clay |
| VZMS-A | | | | | | | |
| 06.0 | ML | 00.0 | 11.0 | 13.2 | 33.8 | 60.0 | 06.3 |
| 09.5 | SP | 00.3 | 01.3 | 86.1 | 76.5 | 17.4 | 06.1 |
| 17.5 | SM | 00.0 | 00.3 | 31.7 | 50.7 | 44.6 | 04.7 |
| 22.0 | SM | 00.0 | 00.0 | 27.9 | 56.2 | 41.1 | 02.7 |
| 28.5 | SM | 00.0 | 00.2 | 58.0 | 68.7 | 28.2 | 03.1 |
| 34.0 | SM | 00.0 | 03.5 | 40.3 | 49.2 | 43.0 | 07.8 |
| 44.0 | ML | 00.0 | 00.0 | 14.5 | 22.5 | 67.0 | 10.4 |
| 50.0 | ML | 00.0 | 03.7 | 18.4 | 35.0 | 56.8 | 08.3 |
| 52.0 | SM | 00.2 | 00.2 | 73.6 | 70.4 | 27.3 | 02.3 |
| 57.5 | SM | 00.0 | 13.8 | 58.2 | 73.0 | 21.6 | 05.4 |
| 62.0 | SP | 00.0 | 25.4 | 64.8 | 77.5 | 18.7 | 03.7 |
| 68.0 | SM | 00.0 | 06.1 | 24.0 | 49.8 | 44.9 | 05.3 |
| 71.0 | SP | 00.0 | 33.2 | 64.4 | 95.7 | 02.7 | 01.7 |
| 79.0 | ML | 00.0 | 01.7 | 09.6 | 39.6 | 53.7 | 06.7 |
| 83.0 | SP | 00.0 | 23.7 | 73.9 | 97.7 | 00.7 | 01.7 |
| 86.0 | SM | 00.0 | 00.9 | 08.2 | 59.9 | 27.2 | 12.8 |
| 88.5 | SW | 00.0 | 00.3 | 94.6 | 100.0 | 00.0 | 00.5 |
| 92.0 | ML | 00.0 | 00.6 | 00.6 | 34.9 | 58.2 | 06.9 |
| 96.0 | SP | 00.0 | 30.6 | 67.7 | 97.2 | 00.8 | 02.0 |
| 99.0 | ML | 00.0 | 00.0 | 00.0 | 31.5 | 59.2 | 09.2 |
| VZMS-B | | | | | | | |
| 07.0 | SP | 00.0 | 00.3 | 38.2 | 83.0 | 12.5 | 04.5 |
| 13.5 | SP | 00.2 | 62.3 | 34.1 | 87.2 | 08.3 | 04.5 |
| 18.5 | SM | 00.0 | 00.4 | 37.6 | 58.6 | 38.2 | 05.2 |
| 22.0 | SM | 00.0 | 00.3 | 26.4 | 52.9 | 43.8 | 03.3 |
| 28.5 | SM | 00.3 | 00.3 | 19.8 | 51.0 | 47.1 | 01.9 |
| 33.5 | SM | 00.0 | 00.4 | 39.7 | 65.9 | 32.5 | 01.6 |
| 38.5 | SM | 00.0 | 00.3 | 39.0 | 67.6 | 30.9 | 01.5 |
| 43.5 | SP | 00.0 | 13.5 | 67.8 | 87.0 | 10.9 | 02.0 |
| 52.0 | SP | 00.0 | 00.2 | 70.5 | 83.2 | 15.5 | 01.3 |
| 58.5 | SP | 00.7 | 13.5 | 49.9 | 82.7 | 14.5 | 02.8 |
| 63.0 | SP | 00.0 | 27.8 | 58.4 | 93.3 | 04.8 | 01.9 |
| 67.0 | ML | 00.0 | 01.3 | 17.6 | 43.6 | 55.5 | 00.9 |
| 73.0 | SP | 00.0 | 17.0 | 76.9 | 98.6 | 00.0 | 01.8 |
| 76.0 | SP | 00.0 | 17.1 | 78.0 | 95.5 | 03.3 | 01.2 |
| 79.5 | SM | 00.0 | 00.3 | 11.5 | 53.3 | 45.3 | 01.4 |
| 86.0 | SM | 00.0 | 00.2 | 27.5 | 51.6 | 40.6 | 07.9 |
| 93.0 | ML | 00.0 | 00.0 | 00.6 | 36.0 | 60.4 | 03.7 |
| 98.5 | SP | 00.0 | 21.2 | 78.9 | 99.0 | 00.4 | 00.6 |

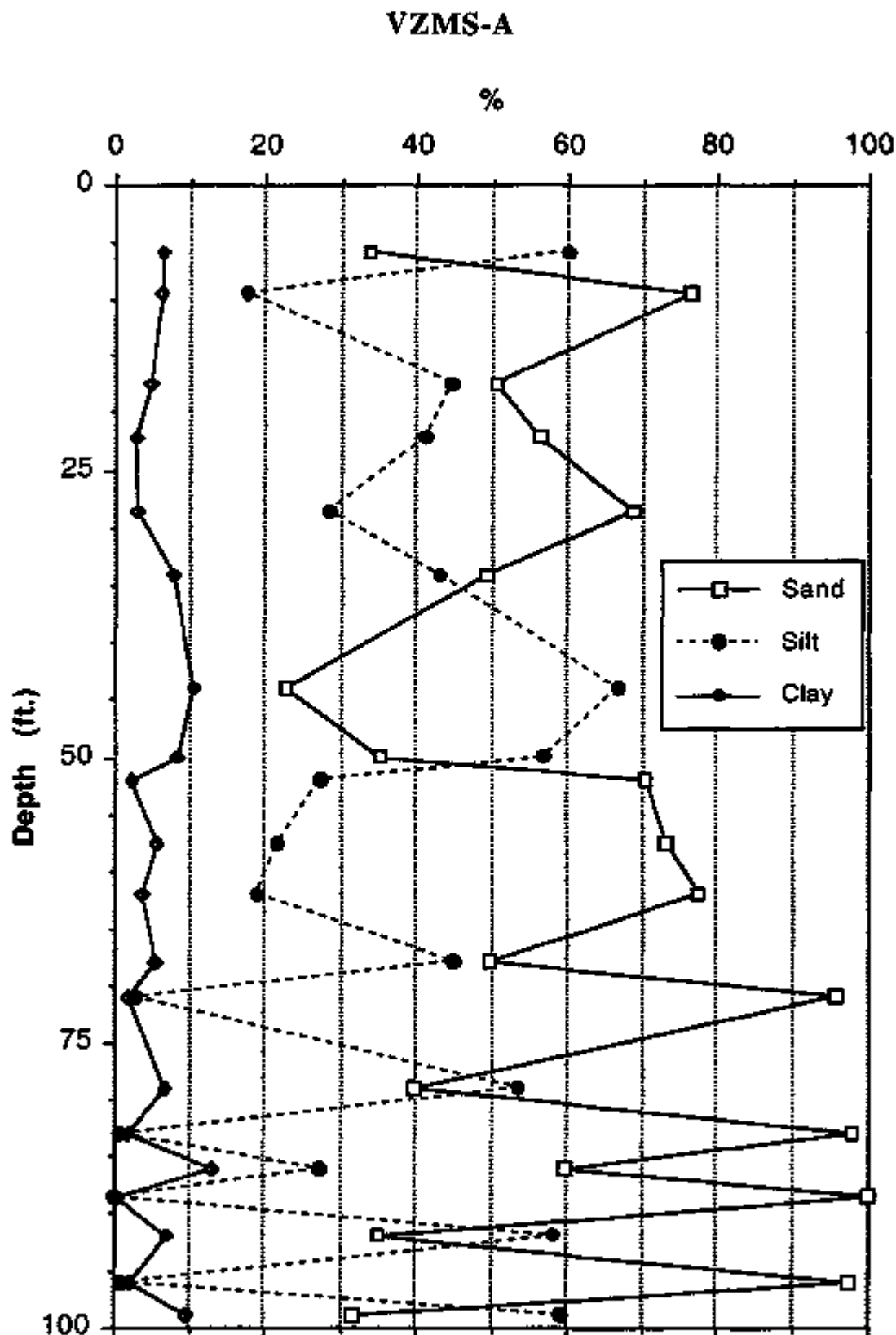

Figure 14. Sand, silt, and clay distributions in VZMS-A.

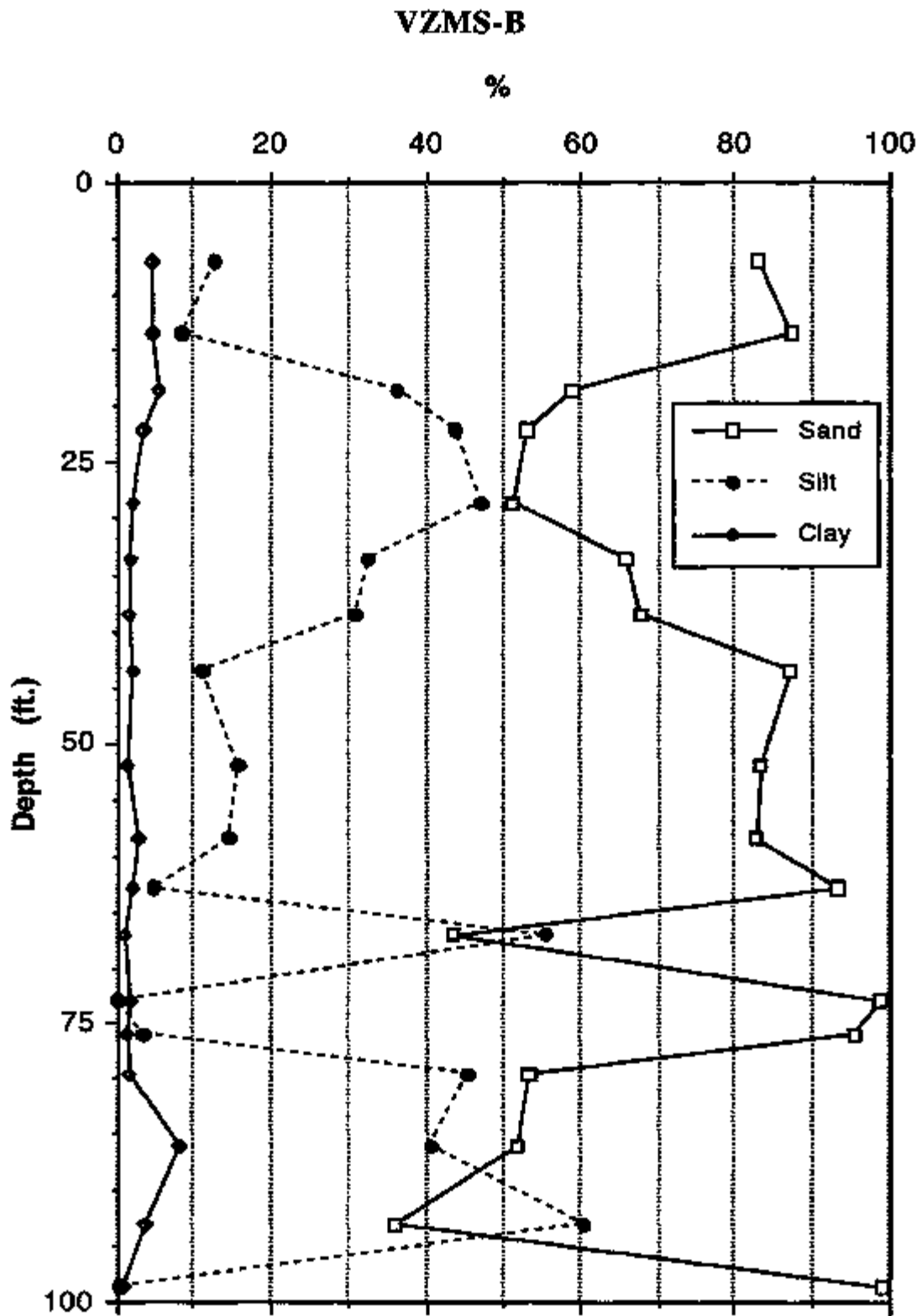

Figure 15. Sand, silt, and clay distributions in VZMS-B.

4.3 Neutron Probe Data

Shortly after the cement grout had set in the neutron probe access holes (12/21/95), preliminary readings were taken. VZMS-NP-1 was found to have an obstruction at a depth of about 25 ft and thus was only logged above that depth. As of the date of this report, this obstruction has not yet been cleared and the hole has not been logged since. VZMS-NP-2 was logged to its total depth of 100 ft bgs. The data for VZMS-NP-2 are presented in Figure 16 and compared with a "relative lithology" as evaluated from the lithologic log. The neutron reading was normalized to the "blank" reading taken with the probe in its shielded casing; this accounts for any changes in source strength or variations in electronic signal. Relative lithology was digitized by assigning increasing values with decreasing particle size: SW=1; SP=2; SM=3; SC=4; ML=5. Therefore, finer-textured materials, such as silts, should have higher moisture contents because of higher water retention properties. As seen in Figure 16, the correlation between higher neutron counts and finer-textured materials is good. In this figure, the upper horizontal axes uses the square root of the relative lithology rankings. There are slight offsets observed in the top 40 ft, suggesting minor error in estimating depths of cores during drilling, which is not unreasonable. Overall, it appears that the neutron probe has excellent sensitivity to moisture variations. Aside from the lithology effect on moisture content, no water or systematic trend with depth are observed.

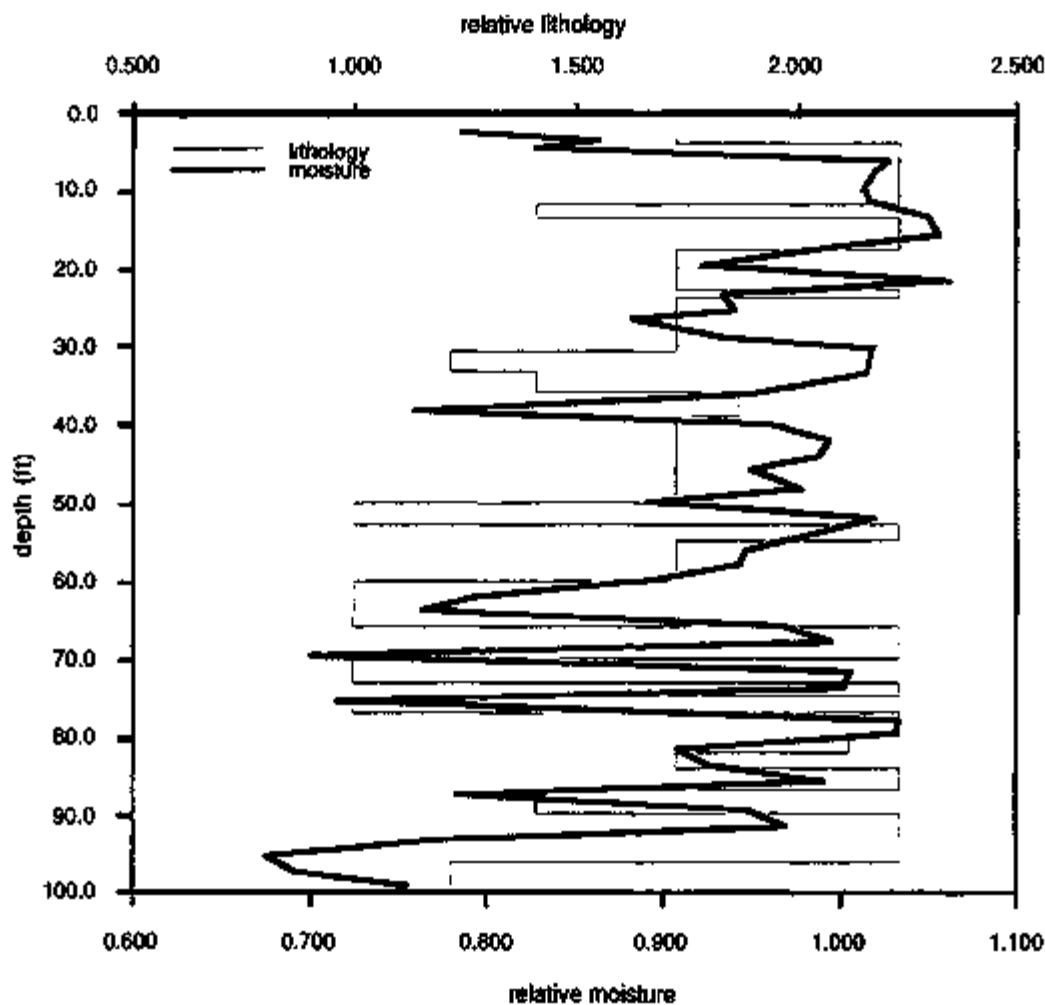

Figure 16. VZMS-NP-2 neutron probe and relative lithologic log.

ACKNOWLEDGMENT

This work was supported by the U.S. Department of Defense under Military Interdepartmental Purchase Request FD2040-96-74020EM to the Ernest Orlando Lawrence Berkeley National Laboratory, managed for the U.S. Department of Energy under contract DE-AC03-76SF00098.

The authors would like to thank Don Lippert, Ray Solbau, Phil Rizzo and John Clyde for their contributions in the design, fabrication and installation of all field equipment and Marque Mesa for his assistance in instrument testing, field work, and data entry. The authors also would like to recognize Radian personnel for their assistance during installation. Finally, the authors wish to thank Curt Oldenburg and Christine Doughty for their careful review of this manuscript.

REFERENCES

- McLaren Environmental Engineering, Inc., 1986. *Final Basewide Report on Contamination, McClellan AFB*. Prepared for Department of the Air Force, Sacramento Air Logistics Center, McClellan AFB. December.
- Jacobs, 1995. *Site Characterization Summary/Field Sampling Plan for IC34*. Prepared for McClellan AFB Environmental Management. August.
- Faybishenko B., 1986. Water-Salt Regime of Soils Under Irrigation. *Agropromizgat*. Moscow. p.314.
- Faybishenko B., 1996. *Omni-Depth Tensiometer*. Patent Pending.

APPENDIX A--THERMISTOR CALIBRATIONS

| THERM | Calibration coefficients | | | Location | |
|---------|--------------------------|----------|----------|----------|-------|
| | A | B | C | Well | LEVEL |
| T 10 | 1.06E-03 | 2.45E-04 | 4.73E-08 | A | 1 |
| T 11 | 1.05E-03 | 2.47E-04 | 3.88E-08 | A | 2 |
| T 12 | 1.04E-03 | 2.48E-04 | 3.38E-08 | A | 3 |
| T 13 | 1.09E-03 | 2.38E-04 | 8.91E-08 | A | 4 |
| T 14 | 1.05E-03 | 2.47E-04 | 4.12E-08 | A | 5 |
| T 17 | 1.05E-03 | 2.47E-04 | 3.82E-08 | A | 6 |
| T 18 | 1.07E-03 | 2.43E-04 | 6.16E-08 | A | 7 |
| T 19 | 1.07E-03 | 2.44E-04 | 5.80E-08 | A | 8 |
| T 20 | 1.05E-03 | 2.46E-04 | 4.73E-08 | A | 9 |
| T 21 | 1.04E-03 | 2.50E-04 | 2.78E-08 | A | 10 |
| T 22 | 1.03E-03 | 2.50E-04 | 2.51E-08 | A | 11 |
| T 23 | 1.07E-03 | 2.44E-04 | 4.98E-08 | A | 12 |
| T 24 | 1.03E-03 | 2.50E-04 | 2.77E-08 | A | 13 |
| T 25 | 1.04E-03 | 2.49E-04 | 2.98E-08 | B | 1 |
| T 26 | 1.05E-03 | 2.47E-04 | 3.99E-08 | B | 2 |
| T 27 | 1.13E-03 | 2.31E-04 | 1.27E-07 | B | 3 |
| T 28 | 1.09E-03 | 2.40E-04 | 7.03E-08 | B | 4 |
| T 29 | 1.04E-03 | 2.49E-04 | 3.11E-08 | B | 5 |
| T 30 | 1.07E-03 | 2.44E-04 | 5.08E-08 | B | 6 |
| T 31 | 1.09E-03 | 2.39E-04 | 7.76E-08 | B | 7 |
| T 32 | 1.14E-03 | 2.33E-04 | 8.52E-08 | B | 8 |
| T 33 | 1.12E-03 | 2.35E-04 | 8.82E-08 | B | 9 |
| T 34 | 1.11E-03 | 2.36E-04 | 8.39E-08 | B | 10 |
| T 35 | 1.11E-03 | 2.37E-04 | 8.48E-08 | B | 11 |
| T 36 | 1.10E-03 | 2.37E-04 | 8.66E-08 | B | 12 |
| T 37 | 1.08E-03 | 2.42E-04 | 6.32E-08 | B | 13 |
| Average | 1.11E-03 | 2.35E-04 | 9.56E-08 | | |

APPENDIX B--VZMS GEOLOGIC LOGS

Vadose Zone Monitoring System Installation Report for McClellan AFB

| BORG # VZMS-A | | SURFACE ELEVATION: | | LOGGED BY: Lisa Gesford | | DATE DRILLED: 12/13/95 | | PAGE: 1/2 | |
|--|--|--|-----------------|--|---|----------------------------------|--|--|--|
| DEPTH TO GROUNDWATER: approx. 110 ft | | DRILLING CONTRACTOR: Water Development | | BORING EQUIPMENT: 6 5/8" HSA | | | | DRILL RIG: CME | |
| DESCRIPTION AND CLASSIFICATION | | | DEPTH (FEET) | SOIL TYPE | Penetration Resistance (Blowings) | PIG readings (ppm) | REMARKS | Well Construction | |
| DESCRIPTION AND REMARKS | | | | | | | | | |
| CONCRETE • fill from 6" to 2.5' | | | | | | | Note: samples named VZMS1 correspond to VZMS-A VZMS1-SG01N • taken at 0942 • in field: 0 ppm VZMS1-SG02N • in field: 33 ppm VZMS1-SG03N • taken at 1015 • in field: 0 ppm VZMS1-SG04N • taken at 1100 • in field: 0 ppm VZMS1-SG05N • taken at 1133 • in field: 0 ppm • QSE | see accompanying well construction log | |
| SILTY SAND (SM), dark brown, munsell: 3 3/3, mod grading, wet, very fine to mod, subrounded | | | 5 | | | | | | |
| CLAYEY SILT (ML), dark grayish brown, munsell: 4 4/2, well graded, wet, very hard | | | 7 | | | | | | |
| SILTY SAND (SM), dark grayish brown, munsell: 4 4/2, very fine to fine, subrounded, moist, silt decreasing with depth | | | 10 | | | | | | |
| SANDY SILT (ML), brown, munsell: 10yr 4/3, very fine to fine, dry to damp | | | 15 | | | | | | |
| SANDY SILT (ML), with interlayered SILTY SAND (SM), brown, munsell: 5 5/3, dry to damp, mod iron staining • from 21.5 to 24 ft minor iron staining • from 20 to 24 ft SILTY SAND (SM) • from 25 to 26 ft SILTY SAND (SM) | | | 20 | | | | | | |
| SAND (SM), with traces of silt, dark brown, munsell: 3 3/3, very fine to fine, subrounded, dry, 5 % mica • moderate iron staining • silt lens from 30 to 31 ft | | | 30 | | | | | | |
| SILT (ML), with traces of sand, brown, munsell: 5 5/3, 5-10% mica, interbedded with SILTY SAND (SM) • minor iron staining • no recovery from 34 to 36 ft • sand lens from 36.5 to 37 ft • from 35 to 37 ft SILTY SAND (SM) • from 41 to 42 ft SILTY SAND (SM) | | | 35 | | | | | | |
| CLAYEY SILT (ML), dark yellowish brown, munsell: 4 4/4, less than 5 % mica, dry • abundant iron staining • interbedded hard silt lens 6" thick from 46.5 to 47 ft | | | 45 | | 0 ppm | | | | |
| SILTY SAND (SM) | | | 50 | | 0 ppm | | | | |
| LBNL | | EXPLORATORY BORING LOG | | | | | | | |
| PROJECT: McClellan VZMS | | DATE: 10/17/96 | | BORING # VZMS-A | | | | | |

| BORING # VZMS-A | | SURFACE ELEVATION: | | LOGGED BY: Lisa Gassford | | DATE DRILLED: 12/13/85 | | PAGE: 2/2 | | |
|--|--|--|--------------------------|--|-----------------|----------------------------------|---|-----------------------|---|---|
| DEPTH TO GROUNDWATER: approx. 110 ft | | DRILLING CONTRACTOR: Water Development | | BORING EQUIPMENT: 6 5/8" NSA | | | DRILL RIG: CME | | | |
| DESCRIPTION AND CLASSIFICATION | | | | | DEPTH (FEET) | SAMPLE | Penetration Resistance (Blow/bls) | PID readings (ppm) | REMARKS | Well Construction |
| DESCRIPTION AND REMARKS | | | | | | | | | | |
| SILTY SAND (SM) continued | | | | | 55 | | | 0 ppm | | see accompanying well construction log |
| SAND (SW), with traces of silt, very dark gray, munsell: 3 3/1, fine to coarse, subrounded, well graded, 10 % mica | | | | | 60 | | | | VZMS1-SG06N • taken at 1157 • in field: 0 ppm | |
| CLAYEY SILT (ML), with traces of sand, brown, munsell: 5 5/3, dry, less than 5 % mica, very hard, abundant iron staining | | | | | 65 | | | | | |
| SAND (ML-SW), with traces of silt, very dark brown, munsell: 3 3/2, very fine to mod, subrounded, less than 5% mica, dry | | | | | 70 | | | 0 ppm | VZMS1-SG07N • taken at 1405 • in field: 0 ppm | |
| CLAYEY SILT (ML), brown, munsell: 4 4/3, dry | | | | | 75 | | | 0 ppm | | |
| SAND (SW), very dark gray brown, munsell: 3 3/2, very fine to mod, well graded, subrounded | | | | | 80 | | | 0 ppm | VZMS1-SG08N • taken at 1440 | |
| CLAYEY SILT (ML), with traces of sand, brown, munsell: 5 5/3, dry | | | | | 85 | | | 0 ppm | | |
| SAND (SP), very dark grayish brown, munsell: 3 3/2, very fine to fine, poorly graded, subrounded, less than 5% mica, dry | | | | | 90 | | | 0 ppm | | |
| CLAYEY SILT (ML), with traces of sand, brown, munsell: 5 5/3, dry, very hard | | | | | 95 | | | 0 ppm | VZMS1-SG09N • taken at 1530 • in field: 0 ppm | |
| SAND (SW), with traces of silt, very dark gray brown, very fine to coarse, well graded, subrounded, 10 % mica, dry | | | | | 100 | | | 0 ppm | | |
| CLAY (CL), with traces of sand, dry, mod plasticity, minor iron staining | | | | | | | | 0 ppm | VZMS1-SG10N • in field: 0 ppm | |
| Total drilled depth = 115 ft • 100 to 115 ft not cored | | | | | | | | | | |
| LBNL | | EXPLORATORY BORING LOG | | | | | | | | |
| PROJECT # McClellan VZMS | | | DATE: 10/17/86 | | | BORING # VZMS-A | | | | |

Vadose Zone Monitoring System Installation Report for McClellan AFB

| BORING # VZMS-B | | SURFACE ELEVATION: | | LOGGED BY: John D Long | | DATE DRILLED: 12/13/95 | | PAGE: 1/2 | |
|--|--|--|--------------|--|--------------------|---|--|--|--|
| DEPTH TO GROUNDWATER: approx. 110 ft | | DRILLING CONTRACTOR: Water Development | | BORING EQUIPMENT: 6 5/8" HSA | | | | DRILL RIG: CME | |
| DESCRIPTION AND CLASSIFICATION | | | | | | | | | |
| DESCRIPTION AND REMARKS | | SOIL TYPE | DEPTH (FEET) | Penetration Resistance (Blow/ft) | PID readings (ppm) | REMARKS | | Well Construction | |
| CONCRETE | | | | | | • start at 1100 hrs | | see accompanying well construction log | |
| • fill-gravel from 6" to 2.5 ft | | | | | | • 3 to 4 ft - only recovery, no samples kept | | | |
| SANDY SILT (SM), brown, 10yr 4/3, wet, indurated, hard | | | 5 | | | Note: samples named VZMS2 correspond to VZMS-B | | | |
| SANDY SILT (SM), 254 5/3, well graded, dry | | | 7.5 | | | VZMS2-SG01N | | | |
| • changes to silt at 8 ft | | | 8 | | | | | | |
| SILT (ML), 54 5/2, dry, iron staining at 9 ft | | | 10 | | | | | | |
| SANDY SILT (ML), well graded, damp | | | 12 | | | | | | |
| SAND (SP), olive, 54 5/3, fine to coarse, mod graded, 90% quartz, 5% malle and mica, damp, iron staining in patches | | | 15 | | | | | | |
| • silty starting at 13 ft | | | 13 | | | | | | |
| SANDY SILT (ML), dark yellow brown, 10yr 4/4, damp, white carbonate and black rootlets parallel to bedding and vertical, 14 to 18 ft | | | 18 | | | | | | |
| SILTY SAND (SM), light olive brown 2.54 5/3, very fine to fine, poorly graded, dry | | | 20 | | | VZMS2-SG02 in field: 53 ppm | | | |
| • iron staining: dark rusting minerals on bedding | | | 20 | | | | | | |
| • mica prominent (95% quartz, 5% mica) | | | 20 | | | | | | |
| • similar lithology through core | | | 20 | | | | | | |
| SANDY SILT (ML) | | | 25 | | | | | | |
| SILTY SAND (SM), light olive brown, 2.54 5/3, very fine to fine, poorly graded, 96% quartz, 5% mica, damp | | | 25 | | | | | | |
| • color change at 27 to 28 ft | | | 27 | | | | | | |
| • parting observed along .5 cm bedding planes, mica (around 29 ft) | | | 29 | | | VZMS2-SG03N • taken at 1233 • in field: 5 ppm | | | |
| SAND (SW-SP), light olive brown, 2.54 5/4, fine to mod, mod graded, subrounded, 90% quartz, 5% malle, 5-10% mica | | | 31 | | | | | | |
| • coarse sand, rusty zones for 31 to 33 ft | | | 31 | | | | | | |
| • return to silty sand for 33 to 34 ft | | | 33 | | | | | | |
| SILTY SAND (SM), light olive brown, 2.6 5/4, fine to coarse, 5% mica | | | 34 | | | | | | |
| • coarser sand, lower % silt than overlying sand | | | 34 | | | | | | |
| SILTY CLAYEY SAND (SM-SL), very fine to fine, 5% mica | | | 40 | | | VZMS2-SG04N • in field: 40.9 ppm | | | |
| SILTY SAND (SM), light olive brown, 2.54 4/3, very fine to fine, subrounded, dry, indurated | | | 43 | | | | | | |
| • 43 to 43.5 ft - coarser silty sand | | | 43 | | | | | | |
| • white carbonate layers at 41 ft | | | 41 | | | | | | |
| • rusty root holes at 44-45 ft | | | 44-45 | | | | | | |
| • trace clay content oscillates in core, clayey silty sand starting at 44 ft | | | 44 | | | | | | |
| CLAYEY SAND (SC) | | | 45 | | | | | | |
| SILTY SAND (SM), with traces of clay, yellow brown, 10yr 5/6, very fine to fine, mod graded, subangular, dry | | | 50 | | | VZMS2-SG05N • in field: 5.6 ppm | | | |
| SAND (SW), with traces of silt, dark yellow brown, 10yr 4/4 | | | 50 | | | | | | |

LBNL

EXPLORATORY BORING LOG

PROJECT #
McClellan VZMS

DATE
10/21/95

BORING #
VZMS-B

| BORING # VZMS-B | | SURFACE ELEVATION: | | LOGGED BY: John D Long | | DATE DRILLED: 12/13/96 | | PAGE: 2/2 | |
|---|--|--|--------------|--|----------------------------------|----------------------------------|---|--|--|
| DEPTH TO GROUNDWATER: approx. 110 ft | | DRILLING CONTRACTOR: Water Development | | BORING EQUIPMENT: 6 5/8" HSA | | | DRILL RIG: CME | | |
| DESCRIPTION AND CLASSIFICATION | | | | | | | | | |
| DESCRIPTION AND REMARKS | | SOIL TYPE | DEPTH (FEET) | SAMPLE | Penetration Resistance (blow/ft) | PID readings (ppm) | REMARKS | Well Construction | |
| SAND (SW) continued | | | | | | | | see accompanying well construction log | |
| SANDY SILT (ML), light olive green, 54 6/2, damp, root traces, predominate iron oxidation | | | 55 | | | | | | |
| SILTY SAND (SM), dark yellow brown, 10yr 4/4, very fine to fine, 1mm holes, well indurated, transition from ML, some crystalline white solids | | | | | | | | | |
| SILTY SAND (SM), light olive brown, 2.54 5/6, very fine to mod, mod graded, 95% quartz, 5% mica, poorly indurated, stringers of white crystalline minerals; at 60 ft, changes to SW | | | 60 | | | | VZMS2-SG06N • taken at 1410 • in field: 6.7 ppm | | |
| SAND (SW), with traces of silt, light olive brown, 2.54 5/3, very fine to fine, mod graded, subangular, damp, 1-2 mm crystalline solids in sand | | | 65 | | | | | | |
| SANDY SILT (ML), olive gray, 54 4/2, mod graded, 5% mica, moist • also clayey from 69 to 70 ft | | | 70 | | | | VZMS2-SG07N • in field: 0 ppm | | |
| SAND (SW), yellow brown, 10yr 5/4, fine to coarse, well graded, subrounded, 5% mica | | | | | | | | | |
| CLAYEY SILT (ML), light olive brown, 2.54 5/3, damp | | | | | | | | | |
| SAND (SW), gray, 54 6/1, fine to coarse, well graded, subrounded, 5% mica, damp, a small 2" wide bed | | | 75 | | | | | | |
| CLAYEY SILT (ML), gray, 54 5/1, dry, indurated • minimal root holes and iron rust noted | | | | | | | | | |
| SANDY SILT (ML), olive gray, 54 5/2, very fine to fine | | | 80 | | | | VZMS2-SG08N • in field: 0 ppm | | |
| SILTY SAND (SM), olive, 54 5/3, very fine to mod, mod graded, subangular, small cm-wide silt interbeds | | | | | | | | | |
| SANDY SILT (ML), olive, 54 5/3, damp, indurated silt, no clay | | | 85 | | | | | | |
| SAND (SP), gray, 54 5/1, very fine to fine, poorly graded, subangular, damp | | | | | | | | | |
| SANDY SILT (ML), olive gray, 54 5/2, very fine to fine, damp, rootholes, iron rusting and indurated | | | 90 | | | | VZMS2-SG08N • taken at 1610 • in field: 0 ppm | | |
| SAND (SP-SW), fine to coarse, mod graded, 5% mafic, 5% mica, damp • color change at 98 ft to rusty orange | | | 95 | | | | | | |
| Total drilled depth = 116 ft • 100 to 115 ft not cored | | | 100 | | | | VZMS2-SG10N • in field: 9.8 ppm | | |
| LBNL | | EXPLORATORY BORING LOG | | | | | | | |
| PROJECT # McClellan VZMS | | DATE 10/21/96 | | BORING # VZMS-B | | | | | |

APPENDIX C--SOIL GAS ANALYSIS

Appendix C is not included here but is printed under a separate cover.

APPENDIX D--SOIL SAMPLE PHYSICAL PROPERTIES

Note that references to VZMS-1 and VZMS-2 correspond to VZMS-A and VZMS-B, respectively.



1181 Quarry Lane, Building 300
Pleasanton, CA 94566
(510) 462-4000 • FAX (510) 462-6283

January 10, 1996

BSK JOB NO. 04-20-0103
P.O. NO. 6418237

Lawrence Berkeley Laboratory
1 Cyclotron Road, Building 50-E
Berkeley, California 94702

Attention: Mr. Curt Oldenburg

Subject: Laboratory Testing Services for your
VZMS Project

Gentlemen:

At your request and authorization, we have performed laboratory testing services on soil from 22 stainless steel tube samples that were obtained from your office on December 18, 1995, and delivered to our laboratory by a member of our staff.

The following laboratory tests were performed on soil from the 22 tube samples:

| <u>Test</u> | <u>Method</u> |
|----------------------------|-----------------|
| Bulk (wet) Density of Soil | ASTM D 2937 |
| Moisture Content of Soil | ASTM D 2216 |
| Specific Gravity of Soil | ASTM D 854 |
| Porosity of Soil | Equation |
| Total Organic Carbon | "Walkley Black" |

The following is a brief description of procedures used to perform the above indicated tests:

- Bulk Density:** The diameter, length and total weight of the samples were determined and from that data, the bulk densities were calculated (weight/volume).
- Moisture Content:** The percent moisture content is the ratio of the weight of water in the sample and the weight of the dry sample. Each moisture sample was obtained from the mid-portion of the tube and oven dried for a minimum of 24 hours at 110°C.
- Specific Gravity:** A specific gravity test was performed on one of the sandy soils and another one was performed on one of silty soils.

Porosity: Porosity is the ratio of volume of voids and total volume of soil and is also a function of soil dry unit weight, specific gravity (determined in the laboratory), and water unit weight (62.4 pcf). The equation used may be provided at your request.

Total Organic Carbon: Procedure may be provided at your request.

Enclosed is a summary of our laboratory test results. We appreciate the opportunity to be of service to you. Should you have questions regarding this report, please contact us.

Respectfully submitted,
BSK & Associates

Alex Y. Eskandari, P.E.
Manager, Geo-Environmental Services
C.E. 38101

Doug Réynolds/
Field and Laboratory Supervisor

AYE:hhc
(RPTS/PROJ04200103.J11)

Enclosure:
Summary of Laboratory Test Data

SUMMARY OF LABORATORY TEST DATA

| Sample Designation | Depth (feet) | Conductivity (µmhos/cm) | Dissolved Oxygen (mg/l) | Specific Gravity | Temperature (°C) | Total Organic Carbon (mg/l) |
|--------------------|--------------|-------------------------|-------------------------|------------------|------------------|-----------------------------|
| VZMS-1* | 5.5 - 6.0 | 36.7 | 98.6 | 2.600 | 55.5 | 200 |
| VZMS-1 | 18.5 - 19.0 | 13.7 | 88.6 | 2.600 | 52.0 | 50 |
| VZMS-1 | 28.5 - 29.0 | 13.7 | 88.6 | 2.600 | 52.0 | 50 |
| VZMS-1 | 48.5 - 49.0 | 41.4 | 111.4 | 2.600 | 51.5 | 90 |
| VZMS-1 | 61.5 - 62.0 | 6.2 | 94.1 | 2.674 | 46.9 | Not Detected |
| VZMS-1* | 78.5 - 79.0 | 33.5 | 86.9 | 2.600 | 59.9 | 50 |
| VZMS-1 | 88.5 - 89.0 | 5.5 | 91.9 | 2.674 | 47.8 | 70 |
| VZMS-1 | 99.0 | 36.8 | 104.5 | 2.600 | 52.9 | 50 |
| VZMS-2 | 18.5 - 19.0 | 25.0 | 112.1 | 2.600 | 44.7 | Not Detected |
| VZMS-2 | 33.5 - 34.0 | 31.3 | 115.0 | 2.600 | 46.0 | 120 |
| VZMS-2 | 48.5 - 49.0 | 27.9 | 107.0 | 2.600 | 48.4 | 50 |
| VZMS-2 | 68.5 - 69.0 | 24.0 | 115.9 | 2.600 | 42.4 | 110 |
| VZMS-2* | 88.0 - 88.5 | 5.5 | 91.9 | 2.674 | 47.8 | 70 |

* Samples were loose and disturbed.