

An Improved Correlation Procedure for Subsize and Full-Size Charpy Impact Specimen Data

Prepared by
M. A. Sokolov, D. J. Alexander

Oak Ridge National Laboratory

RECEIVED
APR 14 1997
OSTI

Prepared for
U.S. Nuclear Regulatory Commission

AVAILABILITY NOTICE

Availability of Reference Materials Cited in NRC Publications

Most documents cited in NRC publications will be available from one of the following sources:

1. The NRC Public Document Room, 2120 L Street, NW., Lower Level, Washington, DC 20555-0001
2. The Superintendent of Documents, U.S. Government Printing Office, P. O. Box 37082, Washington, DC 20402-9328
3. The National Technical Information Service, Springfield, VA 22161-0002

Although the listing that follows represents the majority of documents cited in NRC publications, it is not intended to be exhaustive.

Referenced documents available for inspection and copying for a fee from the NRC Public Document Room include NRC correspondence and internal NRC memoranda; NRC bulletins, circulars, information notices, inspection and investigation notices; licensee event reports; vendor reports and correspondence; Commission papers; and applicant and licensee documents and correspondence.

The following documents in the NUREG series are available for purchase from the Government Printing Office: formal NRC staff and contractor reports, NRC-sponsored conference proceedings, international agreement reports, grantee reports, and NRC booklets and brochures. Also available are regulatory guides, NRC regulations in the *Code of Federal Regulations*, and *Nuclear Regulatory Commission Issuances*.

Documents available from the National Technical Information Service include NUREG-series reports and technical reports prepared by other Federal agencies and reports prepared by the Atomic Energy Commission, forerunner agency to the Nuclear Regulatory Commission.

Documents available from public and special technical libraries include all open literature items, such as books, journal articles, and transactions. *Federal Register* notices, Federal and State legislation, and congressional reports can usually be obtained from these libraries.

Documents such as theses, dissertations, foreign reports and translations, and non-NRC conference proceedings are available for purchase from the organization sponsoring the publication cited.

Single copies of NRC draft reports are available free, to the extent of supply, upon written request to the Office of Administration, Distribution and Mail Services Section, U.S. Nuclear Regulatory Commission, Washington, DC 20555-0001.

Copies of industry codes and standards used in a substantive manner in the NRC regulatory process are maintained at the NRC Library, Two White Flint North, 11545 Rockville Pike, Rockville, MD 20852-2738, for use by the public. Codes and standards are usually copyrighted and may be purchased from the originating organization or, if they are American National Standards, from the American National Standards Institute, 1430 Broadway, New York, NY 10018-3308.

DISCLAIMER NOTICE

This report was prepared as an account of work sponsored by an agency of the United States Government. Neither the United States Government nor any agency thereof, nor any of their employees, makes any warranty, expressed or implied, or assumes any legal liability or responsibility for any third party's use, or the results of such use, of any information, apparatus, product, or process disclosed in this report, or represents that its use by such third party would not infringe privately owned rights.

An Improved Correlation Procedure for Subsize and Full-Size Charpy Impact Specimen Data

Manuscript Completed: June 1995
Date Published: March 1997

Prepared by
M. A. Sokolov, D. J. Alexander

Oak Ridge National Laboratory
Managed by Lockheed Martin Energy Research Corporation

Oak Ridge National Laboratory
Oak Ridge, TN 37831-6285

M. G. Vassilaros, NRC Project Manager

DISTRIBUTION OF THIS DOCUMENT IS UNLIMITED

ph

Prepared for
Division of Engineering Technology
Office of Nuclear Regulatory Research
U.S. Nuclear Regulatory Commission
Washington, DC 20555-0001
NRC Job Code L1098

MASTER

Abstract

The possibility of using subsize specimens to monitor the properties of reactor pressure vessel steels is receiving increasing attention for light-water reactor plant life extension. This potential results from the possibility of cutting samples of small volume from the internal surface of the pressure vessel for determination of the actual properties of the operating pressure vessel. In addition, plant life extension will require supplemental data that cannot be provided by existing surveillance programs. Testing of subsize specimens manufactured from broken halves of previously tested surveillance Charpy specimens offers an attractive means of extending existing surveillance programs. Using subsize Charpy V-notch-type specimens requires the establishment of a specimen geometry that is adequate to obtain a ductile-to-brittle transition curve similar to that obtained from full-size specimens, and the development of correlations for transition temperature and upper-shelf energy (USE) level between subsize and full-size specimens. Five different geometries of subsize specimens were selected for testing and evaluation. The specimens were made from several types of pressure vessel steels with a wide range of yield strengths, transition temperatures, and USEs. The effects of specimen dimensions, including notch depth, angle, and radius, have been studied. The correlations of transition temperatures determined from different types of subsize specimens and the full-size specimens are presented. A new procedure for transforming data from subsize specimens is developed. The transformed data are in good agreement with data from full-size specimens for materials that have USE levels less than 200 J.

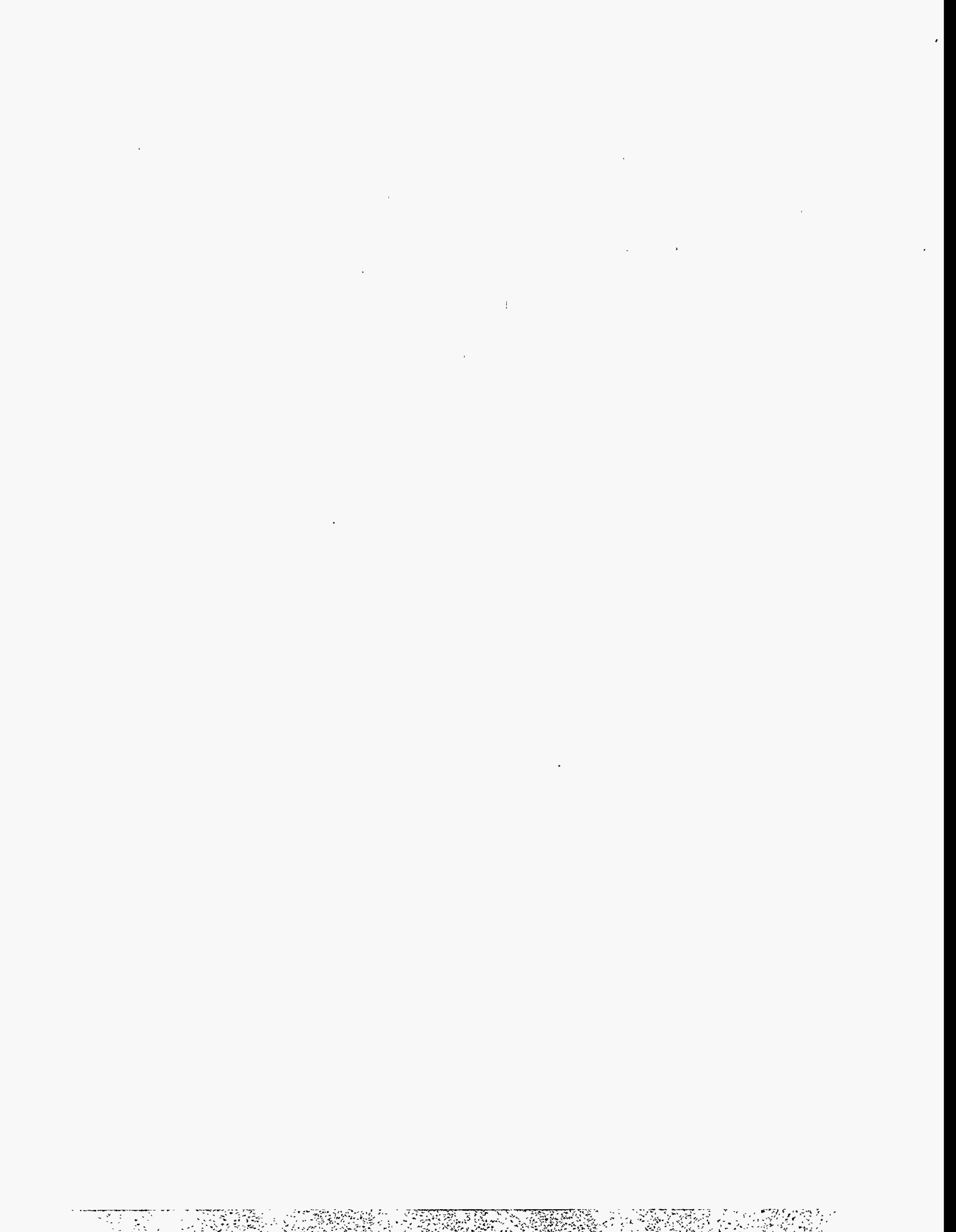

DISCLAIMER

Portions of this document may be illegible in electronic image products. Images are produced from the best available original document.

DISCLAIMER

This report was prepared as an account of work sponsored by an agency of the United States Government. Neither the United States Government nor any agency thereof, nor any of their employees, make any warranty, express or implied, or assumes any legal liability or responsibility for the accuracy, completeness, or usefulness of any information, apparatus, product, or process disclosed, or represents that its use would not infringe privately owned rights. Reference herein to any specific commercial product, process, or service by trade name, trademark, manufacturer, or otherwise does not necessarily constitute or imply its endorsement, recommendation, or favoring by the United States Government or any agency thereof. The views and opinions of authors expressed herein do not necessarily state or reflect those of the United States Government or any agency thereof.

Contents

	Page
Abstract	iii
Table of Contents	v
List of Figures	vi
List of Tables	viii
Foreword	ix
Acknowledgments	xv
Introduction	1
Materials	1
Specimen Designs	1
Testing Procedure	3
Effects of Specimen Dimensions	8
Correlation of Absorbed Energy Between Full-Size and Subsize Specimens	12
Correlation of Transition Temperature of Full-Size and Subsize Specimens	24
Normalization of Data from Subsize Specimens	28
Summary and Conclusions	29
References	37
Appendix A – A 533 Grade B Wide Plate, LT Orientation	A-1
Appendix B – A 533 Grade B Wide Plate, TL Orientation	B-1
Appendix C – A 508, As Quenched	C-1
Appendix D – A 508, Quenched and Tempered at 599°C	D-1
Appendix E – A 508, Quenched and Tempered at 677°C	E-1
Appendix F – A 508, Quenched and Tempered at 704°C	F-1
Appendix G – HSST Plate 02, Quarter Thickness, TL Orientation	G-1
Appendix H –HSST Plate 02, Half Thickness, TL Orientation	H-1
Appendix I –HSST Plate 14, Quenched and Tempered at 950°C	I-1
Appendix J – 15Kh2MFA, Forging 103672	J-1
Appendix K – HSSI Weld 72W	K-1

Figures

	Page
1 Dimensions of subsize specimens used in this study	4
2 Full-size and subsize specimens used in this study	5
3 Comparison of notch dimensions of full-size and subsize specimens used in this work: (a) full size, (b) type 1, (c) type 2, (d) type 3, and (e) type 4	6
4 Absorbed energy versus test temperature for type 3 specimens from HSST Plate 02, quarter-thickness location, with 0.8-, 1.0-, and 1.7-mm V-notch depths	9
5 Absorbed energy versus test temperature for type 3 specimens from HSST Plate 02, quarter-thickness location, with 0.25- and 0.10-mm V-notch root radii	10
6 Absorbed energy versus test temperature for type 1 subsize specimens from HSST Plate 02, quarter-thickness location, with 30 and 45° V-notch angles	10
7 Absorbed energy versus test temperature for type 4 subsize specimens from HSST Plate 02, quarter-thickness location, tested at 22- and 20-mm span	11
8 Absorbed energy versus test temperature for types 3 and 5 specimens of weld 72W tested at 40- and 20-mm span	11
9 Absorbed energy versus test temperature for types 3 and 5 specimens of HSST Plate 02, half-thickness location, tested at 40- and 20-mm span	12
10 Absorbed energy versus test temperature for type 4 specimens of weld 72W tested at impact velocities of 5.5 and 2.25 m/s	13
11 Absorbed energy versus test temperature for type 3 specimens of HSST Plate 02, quarter-thickness location, tested at impact velocities of 5.5 and 2.25 m/s	13
12 Definition of specimen dimensions	15
13 Correlation of upper-shelf energies of full-size and type 1 subsize specimens	18
14 Correlation of upper-shelf energies of full-size and type 2 subsize specimens	18
15 Correlation of upper-shelf energies of full-size and type 3 subsize specimens	19
16 Correlation of upper-shelf energies of full-size and type 4 subsize specimens	19
17 The ratio of upper-shelf energy (USE) of full-size specimens to USE of type 1 specimens as a function of yield strength	20
18 The ratio of upper-shelf energy (USE) of full-size specimens to USE of type 2 specimens as a function of yield strength	20
19 The ratio of upper-shelf energy (USE) of full-size specimens to USE of type 3 specimens as a function of yield strength	21

20	The ratio of upper-shelf energy (USE) of full-size specimens to USE of type 4 specimens as a function of yield strength	21
21	Load versus displacement record showing the definitions of the various load points	23
22	Stress-temperature diagram showing the effect of specimen size on transition temperature	25
23	Correlation of transition temperatures determined with data from full-size specimens and normalized data from type 1 subsize specimens	26
24	Correlation of transition temperatures determined with data from full-size specimens and normalized data from type 2 subsize specimens	26
25	Correlation of transition temperatures determined with data from full-size specimens and normalized data from type 3 subsize specimens	27
26	Correlation of transition temperatures determined with data from full-size specimens and normalized data from type 4 subsize specimens	27
27	Temperature correction for subsize specimens as a function of nominal fracture volume	28
28	Comparison of Charpy curve for full-size specimens of A 508, as-quenched, with data from subsize specimens normalized by the proposed procedure	30
29	Comparison of Charpy curve for full-size specimens of A 508, quenched and tempered at 599°C, with data from subsize specimens normalized by the proposed procedure	30
30	Comparison of Charpy curve for full-size specimens of A 508, quenched and tempered at 677°C, with data from subsize specimens normalized by the proposed procedure	31
31	Comparison of Charpy curve for full-size specimens of A 508, quenched and tempered at 704°C, with data from subsize specimens normalized by the proposed procedure	31
32	Comparison of Charpy curve for full-size specimens of HSST Plate 02, T-L orientation, quarter thickness, with data from subsize specimens normalized by the proposed procedure	32
33	Comparison of Charpy curve for full-size specimens of HSST Plate 14, quenched and tempered at 950°C, with data from subsize specimens normalized by the proposed procedure	32
34	Comparison of Charpy curve for full-size specimens of 15Kh2MFA with data from subsize specimens normalized by the proposed procedure	33
35	Comparison of Charpy curve for full-size specimens of HSSI weld 72W with data from subsize Charpy specimens normalized by the proposed procedure	33
36	Comparison of Charpy curve for full-size specimens of A 533 wide plate, L-T orientation, with data from subsize Charpy specimens normalized by the proposed procedure	34
37	Comparison of Charpy curve for full-size specimens of A 533 wide plate, T-L orientation, with data from subsize Charpy specimens normalized by the proposed procedure	34

Tables

Page

1	Test matrix and mechanical properties of materials for subsize Charpy specimen evaluation	2
2	Comparison of different normalization factors for upper-shelf energy as ratios of different specimen dimensions	15
3	Upper-shelf energies obtained for materials for subsize Charpy specimen evaluation	17
4	Effects of changes in percent shear on values of transition temperatures at 41 and 68 J for normalized data from type 3 specimens of HSST Plate 02	23

Foreword

The work reported here was performed at the Oak Ridge National Laboratory (ORNL) under the Heavy-Section Steel Irradiation (HSSI) Program, W. R. Corwin, Program Manager. The program is sponsored by the Office of Nuclear Regulatory Research of the U.S. Nuclear Regulatory Commission (NRC). The technical monitor for the NRC is M. G. Vassilaros.

This report is designated HSSI Report 14. Reports in this series are listed below:

1. F. M. Haggag, W. R. Corwin, and R. K. Nanstad, Martin Marietta Energy Systems, Inc., Oak Ridge Natl. Lab., Oak Ridge, Tenn., *Irradiation Effects on Strength and Toughness of Three-Wire Series-Arc Stainless Steel Weld Overlay Cladding*, USNRC Report NUREG/CR-5511 (ORNL/TM-11439), February 1990.
2. L. F. Miller, C. A. Baldwin, F. W. Stallman, and F. B. K. Kam, Martin Marietta Energy Systems, Inc., Oak Ridge Natl. Lab., Oak Ridge, Tenn., *Neutron Exposure Parameters for the Metallurgical Test Specimens in the Sixth Heavy-Section Steel Irradiation Series*, USNRC Report NUREG/CR-5409 (ORNL/TM-11267), March 1990.
3. S. K. Iskander, W. R. Corwin, and R. K. Nanstad, Martin Marietta Energy Systems, Inc., Oak Ridge Natl. Lab., Oak Ridge, Tenn., *Results of Crack-Arrest Tests on Two Irradiated High-Copper Welds*, NUREG/CR-5584 (ORNL/TM-11575), December 1990.
4. R. K. Nanstad and R. G. Berggren, Martin Marietta Energy Systems, Inc., Oak Ridge Natl. Lab., Oak Ridge, Tenn., *Irradiation Effects on Charpy Impact and Tensile Properties of Low Upper-Shelf Welds, HSSI Series 2 and 3*, NUREG/CR-5696 (ORNL/TM-11804), August 1991.
5. R. E. Stoller, Martin Marietta Energy Systems, Inc., Oak Ridge Natl. Lab., Oak Ridge, Tenn., *Modeling the Influence of Irradiation Temperature and Displacement Rate on Radiation-Induced Hardening in Ferritic Steels*, USNRC Report NUREG/CR-5859 (ORNL/TM-12073), August 1992.
6. R. K. Nanstad, D. E. McCabe, and R. L. Swain, Martin Marietta Energy Systems, Inc., Oak Ridge Natl. Lab., Oak Ridge, Tenn., *Chemical Composition RT_{NDT} Determinations for Midland Weld WF-70*, USNRC Report NUREG/CR-5914 (ORNL-6740), December 1992.
7. R. K. Nanstad, F. M. Haggag, D. E. McCabe, S. K. Iskander, K. O. Bowman, and B. H. Menke, Martin Marietta Energy Systems, Inc., Oak Ridge Natl. Lab., Oak Ridge, Tenn., *Irradiation Effects on Fracture Toughness of Two High-Copper Submerged-Arc Welds*, USNRC Report NUREG/CR-5913 (ORNL/TM-12156/V1), October 1992.
8. S. K. Iskander, W. R. Corwin, and R. K. Nanstad, Martin Marietta Energy Systems, Inc., Oak Ridge Natl. Lab., Oak Ridge, Tenn., *Crack-Arrest Tests on Two Irradiated High-Copper Welds*, USNRC Report NUREG/CR-6139 (ORNL/TM-12513), March 1994.
9. R. E. Stoller, Martin Marietta Energy Systems, Inc., Oak Ridge Natl. Lab., Oak Ridge, Tenn., *A Comparison of the Relative Importance of Copper Precipitates and Point Defects in Reactor Pressure Vessel Embrittlement*, USNRC Report NUREG/CR-6231 (ORNL/TM-6811), December 1994.
10. D. E. McCabe, R. K. Nanstad, S. K. Iskander, and R. L. Swain, Martin Marietta Energy Systems, Inc., Oak Ridge Natl. Lab., Oak Ridge, Tenn., *Unirradiated Material Properties of Midland Weld WF-70*, USNRC Report NUREG/CR-6249 (ORNL/TM-12777), October 1994.
11. P. M. Rice and R. E. Stoller, Lockheed Martin Energy Systems, Oak Ridge Natl. Lab., Oak Ridge, Tenn., *Microstructural Characterization of Selected AEA/UCSB Model FeCuMn Alloys*, USNRC Report NUREG/CR-6332 (ORNL/TM-12980), to be published.

12. J. H. Giovanola and J. E. Crocker, SRI International, *Fracture Toughness Testing with Cracked Round Bars: Feasibility Study*, USNRC Report NUREG/CR-6342 (ORNL/Sub/94-DHK60), to be published.
13. F. M. Haggag and R. K. Nanstad, Lockheed Martin Energy Systems, Oak Ridge Natl. Lab., Oak Ridge, Tenn., *Effects of Thermal Aging and Neutron Irradiation on the Mechanical Properties of Three-Wire Stainless Steel Weld Overlay Cladding*, USNRC Report NUREG/CR-6363 (ORNL/TM-13047), to be published.
14. This report.

The HSSI Program includes both follow-on and the direct continuation of work that was performed under the Heavy-Section Steel Technology (HSST) Program. Previous HSST reports related to irradiation effects in pressure vessel materials and those containing unirradiated properties of materials used in HSSI and HSST irradiation programs are tabulated below as a convenience to the reader.

C. E. Childress, Union Carbide Corp. Nuclear Div., Oak Ridge Natl. Lab., Oak Ridge, Tenn., *Fabrication History of the First Two 12-in.-Thick A-533 Grade B, Class 1 Steel Plates of the Heavy-Section Steel Technology Program*, ORNL-4313, February 1969.

T. R. Mager and F. O. Thomas, Westinghouse Electric Corporation, PWR Systems Division, Pittsburgh, Pa., *Evaluation by Linear Elastic Fracture Mechanics of Radiation Damage to Pressure Vessel Steels*, WCAP-7328 (Rev.), October 1969.

P. N. Randall, TRW Systems Group, Redondo Beach, Calif., *Gross Strain Measure of Fracture Toughness of Steels*, HSSTP-TR-3, Nov. 1, 1969.

L. W. Loechel, Martin Marietta Corporation, Denver, Colo., *The Effect of Testing Variables on the Transition Temperature in Steel*, MCR-69-189, Nov. 20, 1969.

W. O. Shabbits, W. H. Pryle, and E. T. Wessel, Westinghouse Electric Corporation, PWR Systems Division, Pittsburgh, Pa., *Heavy-Section Fracture Toughness Properties of A533 Grade B Class 1 Steel Plate and Submerged Arc Weldment*, WCAP-7414, December 1969.

C. E. Childress, Union Carbide Corp. Nuclear Div., Oak Ridge Natl. Lab., Oak Ridge, Tenn., *Fabrication History of the Third and Fourth ASTM A-533 Steel Plates of the Heavy-Section Steel Technology Program*, ORNL-4313-2, February 1970.

P. B. Crosley and E. J. Ripling, Materials Research Laboratory, Inc., Glenwood, Ill., *Crack Arrest Fracture Toughness of A533 Grade B Class 1 Pressure Vessel Steel*, HSSTP-TR-8, March 1970.

F. J. Loss, Naval Research Laboratory, Washington, D.C., *Dynamic Tear Test Investigations of the Fracture Toughness of Thick-Section Steel*, NRL-7056, May 14, 1970.

T. R. Mager, Westinghouse Electric Corporation, PWR Systems Division, Pittsburgh, Pa., *Post-Irradiation Testing of 2T Compact Tension Specimens*, WCAP-7561, August 1970.

F. J. Witt and R. G. Berggren, Union Carbide Corp. Nuclear Div., Oak Ridge Natl. Lab., Oak Ridge, Tenn., *Size Effects and Energy Disposition in Impact Specimen Testing of ASTM A533 Grade B Steel*, ORNL/TM-3030, August 1970.

D. A. Canonico, Union Carbide Corp. Nuclear Div., Oak Ridge Natl. Lab., Oak Ridge, Tenn., *Transition Temperature Considerations for Thick-Wall Nuclear Pressure Vessels*, ORNL/TM-3114, October 1970.

T. R. Mager, Westinghouse Electric Corporation, PWR Systems Division, Pittsburgh, Pa., *Fracture Toughness Characterization Study of A533, Grade B, Class 1 Steel*, WCAP-7578, October 1970.

W. O. Shabbits, Westinghouse Electric Corporation, PWR Systems Division, Pittsburgh, Pa., *Dynamic Fracture Toughness Properties of Heavy-Section A533 Grade B Class 1 Steel Plate*, WCAP-7623, December 1970.

C. E. Childress, Union Carbide Corp. Nuclear Div., Oak Ridge Natl. Lab., Oak Ridge, Tenn., *Fabrication Procedures and Acceptance Data for ASTM A-533 Welds and a 10-in.-Thick ASTM A-533 Plate of the Heavy-Section Steel Technology Program*, ORNL-TM-4313-3, January 1971.

D. A. Canonico and R. G. Berggren, Union Carbide Corp. Nuclear Div., Oak Ridge Natl. Lab., Oak Ridge, Tenn., *Tensile and Impact Properties of Thick-Section Plate and Weldments*, ORNL/TM-3211, January 1971.

C. W. Hunter and J. A. Williams, Hanford Eng. Dev. Lab., Richland, Wash., *Fracture and Tensile Behavior of Neutron-Irradiated A533-B Pressure Vessel Steel*, HEDL-TME-71-76, Feb. 6, 1971.

C. E. Childress, Union Carbide Corp. Nuclear Div., Oak Ridge Natl. Lab., Oak Ridge, Tenn., *Manual for ASTM A533 Grade B Class 1 Steel (HSST Plate 03) Provided to the International Atomic Energy Agency*, ORNL/TM-3193, March 1971.

P. N. Randall, TRW Systems Group, Redondo Beach, Calif., *Gross Strain Crack Tolerance of A533-B Steel*, HSSTP-TR-14, May 1, 1971.

C. L. Segaser, Union Carbide Corp. Nuclear Div., Oak Ridge Natl. Lab., Oak Ridge, Tenn., *Feasibility Study, Irradiation of Heavy-Section Steel Specimens in the South Test Facility of the Oak Ridge Research Reactor*, ORNL/TM-3234, May 1971.

H. T. Corten and R. H. Sailors, University of Illinois, Urbana, Ill., *Relationship Between Material Fracture Toughness Using Fracture Mechanics and Transition Temperature Tests*, T&AM Report 346, Aug. 1, 1971.

L. A. James and J. A. Williams, Hanford Eng. Dev. Lab., Richland, Wash., *Heavy-Section Steel Technology Program Technical Report No. 21, The Effect of Temperature and Neutron Irradiation Upon the Fatigue-Crack Propagation Behavior of ASTM A533 Grade B, Class 1 Steel*, HEDL-TME 72-132, September 1972.

P. B. Crosley and E. J. Ripling, Materials Research Laboratory, Inc., Glenwood, Ill., *Crack Arrest in an Increasing K-Field*, HSSTP-TR-27, January 1973.

W. J. Stelzman and R. G. Berggren, Union Carbide Corp. Nuclear Div., Oak Ridge Natl. Lab., Oak Ridge, Tenn., *Radiation Strengthening and Embrittlement in Heavy-Section Steel Plates and Welds*, ORNL-4871, June 1973.

J. M. Steichen and J. A. Williams, Hanford Eng. Dev. Lab., Richland, Wash., *High Strain Rate Tensile Properties of Irradiated ASTM A533 Grade B Class 1 Pressure Vessel Steel*, HEDL-TME 73-74, July 1973.

J. A. Williams, Hanford Eng. Dev. Lab., Richland, Wash., *The Irradiation and Temperature Dependence of Tensile and Fracture Properties of ASTM A533, Grade B, Class 1 Steel Plate and Weldment*, HEDL-TME 73-75, August 1973.

J. A. Williams, Hanford Eng. Dev. Lab., Richland, Wash., *Some Comments Related to the Effect of Rate on the Fracture Toughness of Irradiated ASTM A553-B Steel Based on Yield Strength Behavior*, HEDL-SA 797, December 1974.

J. A. Williams, Hanford Eng. Dev. Lab., Richland, Wash., *The Irradiated Fracture Toughness of ASTM A533, Grade B, Class 1 Steel Measured with a Four-Inch-Thick Compact Tension Specimen*, HEDL-TME 75-10, January 1975.

J. G. Merkle, G. D. Whitman, and R. H. Bryan, Union Carbide Corp. Nuclear Div., Oak Ridge Natl. Lab., Oak Ridge, Tenn., *An Evaluation of the HSST Program Intermediate Pressure Vessel Tests in Terms of Light-Water-Reactor Pressure Vessel Safety*, ORNL/TM-5090, November 1975.

J. A. Davidson, L. J. Ceschini, R. P. Shogan, and G. V. Rao, Westinghouse Electric Corporation, PWR Systems Division, Pittsburgh, Pa., *The Irradiated Dynamic Fracture Toughness of ASTM A533, Grade B, Class 1 Steel Plate and Submerged Arc Weldment*, WCAP-8775, October 1976.

J. A. Williams, Hanford Eng. Dev. Lab., Richland, Wash., *Tensile Properties of Irradiated and Unirradiated Welds of A533 Steel Plate and A508 Forgings*, USNRC Report NUREG/CR-1158 (ORNL/SUB-79/50917/2), July 1979.

J. A. Williams, Hanford Eng. Dev. Lab., Richland, Wash., *The Ductile Fracture Toughness of Heavy-Section Steel Plate*, USNRC Report NUREG/CR-0859, September 1979.

K. W. Carlson and J. A. Williams, Hanford Eng. Dev. Lab., Richland, Wash., *The Effect of Crack Length and Side Grooves on the Ductile Fracture Toughness Properties of ASTM A533 Steel*, USNRC Report NUREG/CR-1171 (ORNL/SUB-79/50917/3), October 1979.

G. A. Clarke, Westinghouse Electric Corp., PWR Systems Division, Pittsburgh, Pa., *An Evaluation of the Unloading Compliance Procedure for J-Integral Testing in the Hot Cell, Final Report*, USNRC Report NUREG/CR-1070 (ORNL/SUB-7394/1), October 1979.

P. B. Crosley and E. J. Ripling, Materials Research Laboratory, Inc., Glenwood, Ill., *Development of a Standard Test for Measuring K_{Ia} with a Modified Compact Specimen*, USNRC Report NUREG/CR-2294 (ORNL/SUB-81/7755/1), August 1981.

H. A. Domian, Babcock and Wilcox Company, Alliance, Ohio, *Vessel V-8 Repair and Preparation of Low Upper-Shelf Weldment*, USNRC Report NUREG/CR-2676 (ORNL/SUB/81-85813/1), June 1982.

R. D. Cheverton, S. K. Iskander, and D. G. Ball, Union Carbide Corp. Nuclear Div., Oak Ridge Natl. Lab., Oak Ridge, Tenn., *PWR Pressure Vessel Integrity During Overcooling Accidents: A Parametric Analysis*, USNRC Report NUREG/CR-2895 (ORNL/TM-7931), February 1983.

J. G. Merkle, Union Carbide Corp. Nuclear Div., Oak Ridge Natl. Lab., Oak Ridge, Tenn., *An Examination of the Size Effects and Data Scatter Observed in Small Specimen Cleavage Fracture Toughness Testing*, USNRC Report NUREG/CR-3672 (ORNL/TM-9088), April 1984.

W. R. Corwin, Martin Marietta Energy Systems, Inc., Oak Ridge Natl. Lab., Oak Ridge, Tenn., *Assessment of Radiation Effects Relating to Reactor Pressure Vessel Cladding*, USNRC Report NUREG/CR-3671 (ORNL-6047), July 1984.

W. R. Corwin, R. G. Berggren, and R. K. Nanstad, Martin Marietta Energy Systems, Inc., Oak Ridge Natl. Lab., Oak Ridge, Tenn., *Charpy Toughness and Tensile Properties of a Neutron Irradiated Stainless Steel Submerged-Arc Weld Cladding Overlay*, USNRC Report NUREG/CR-3927 (ORNL/TM-9709), September 1984.

J. J. McGowan, Martin Marietta Energy Systems, Inc., Oak Ridge Natl. Lab., Oak Ridge, Tenn., *Tensile Properties of Irradiated Nuclear Grade Pressure Vessel Plate and Welds for the Fourth HSST Irradiation Series*, USNRC Report NUREG/CR-3978 (ORNL/TM-9516), January 1985.

J. J. McGowan, Martin Marietta Energy Systems, Inc., Oak Ridge Natl. Lab., Oak Ridge, Tenn., *Tensile Properties of Irradiated Nuclear Grade Pressure Vessel Welds for the Third HSST Irradiation Series*, USNRC Report NUREG/CR-4086 (ORNL/TM-9477), March 1985.

W. R. Corwin, G. C. Robinson, R. K. Nanstad, J. G. Merkle, R. G. Berggren, G. M. Goodwin, R. L. Swain, and T. D. Owings, Martin Marietta Energy Systems, Inc., Oak Ridge Natl. Lab., Oak Ridge, Tenn., *Effects of Stainless Steel Weld Overlay Cladding on the Structural Integrity of Flawed Steel Plates in Bending, Series 1*, USNRC Report NUREG/CR-4015 (ORNL/TM-9390), April 1985.

W. J. Stelzman, R. G. Berggren, and T. N. Jones, Martin Marietta Energy Systems, Inc., Oak Ridge Natl. Lab., Oak Ridge, Tenn., *ORNL Characterization of Heavy-Section Steel Technology Program Plates 01, 02, and 03*, USNRC Report NUREG/CR-4092 (ORNL/TM-9491), April 1985.

G. D. Whitman, Martin Marietta Energy Systems, Inc., Oak Ridge Natl. Lab., Oak Ridge, Tenn., *Historical Summary of the Heavy-Section Steel Technology Program and Some Related Activities in Light-Water Reactor Pressure Vessel Safety Research*, USNRC Report NUREG/CR-4489 (ORNL-6259), March 1986.

R. H. Bryan, B. R. Bass, S. E. Bolt, J. W. Bryson, J. G. Merkle, R. K. Nanstad, and G. C. Robinson, Martin Marietta Energy Systems, Inc., Oak Ridge Natl. Lab., Oak Ridge, Tenn., *Test of 6-in.-Thick Pressure Vessels. Series 3: Intermediate Test Vessel V-8A — Tearing Behavior of Low Upper-Shelf Material*, USNRC Report NUREG-CR-4760 (ORNL-6187), May 1987.

D. B. Barker, R. Chona, W. L. Fourney, and G. R. Irwin, University of Maryland, College Park, Md., *A Report on the Round Robin Program Conducted to Evaluate the Proposed ASTM Standard Test Method for Determining the Plane Strain Crack Arrest Fracture Toughness, K_{Ia} , of Ferritic Materials*, NUREG/CR-4966 (ORNL/SUB/79-7778/4), January 1988.

L. F. Miller, C. A. Baldwin, F. W. Stallman, and F. B. K. Kam, Martin Marietta Energy Systems, Inc., Oak Ridge Natl. Lab., Oak Ridge, Tenn., *Neutron Exposure Parameters for the Metallurgical Test Specimens in the Fifth Heavy-Section Steel Technology Irradiation Series Capsules*, NUREG/CR-5019 (ORNL/TM-10582), March 1988.

J. J. McGowan, R. K. Nanstad, and K. R. Thoms, Martin Marietta Energy Systems, Inc., Oak Ridge Natl. Lab., Oak Ridge, Tenn., *Characterization of Irradiated Current-Practice Welds and A533 Grade B Class 1 Plate for Nuclear Pressure Vessel Service*, USNRC Report NUREG/CR-4880 (ORNL-6484/V1 and V2), July 1988.

R. D. Cheverton, W. E. Pennell, G. C. Robinson, and R. K. Nanstad, Martin Marietta Energy Systems, Inc., Oak Ridge Natl. Lab., Oak Ridge, Tenn., *Impact of Radiation Embrittlement on Integrity of Pressure Vessel Supports for Two PWR Plants*, USNRC Report NUREG/CR-5320 (ORNL/TM-10966), February 1989.

J. G. Merkle, Martin Marietta Energy Systems, Inc., Oak Ridge Natl. Lab., Oak Ridge, Tenn., *An Overview of the Low-Upper-Shelf Toughness Safety Margin Issue*, USNRC Report NUREG/CR-5552 (ORNL/TM-11314), August 1990.

R. D. Cheverton, T. L. Dickson, J. G. Merkle, and R. K. Nanstad, Martin Marietta Energy Systems, Inc., Oak Ridge Natl. Lab., Oak Ridge, Tenn., *Review of Reactor Pressure Vessel Evaluation Report for Yankee Rowe Nuclear Power Station (YAEC No. 1735)*, USNRC Report NUREG/CR-5799 (ORNL/TM-11982), March 1992.

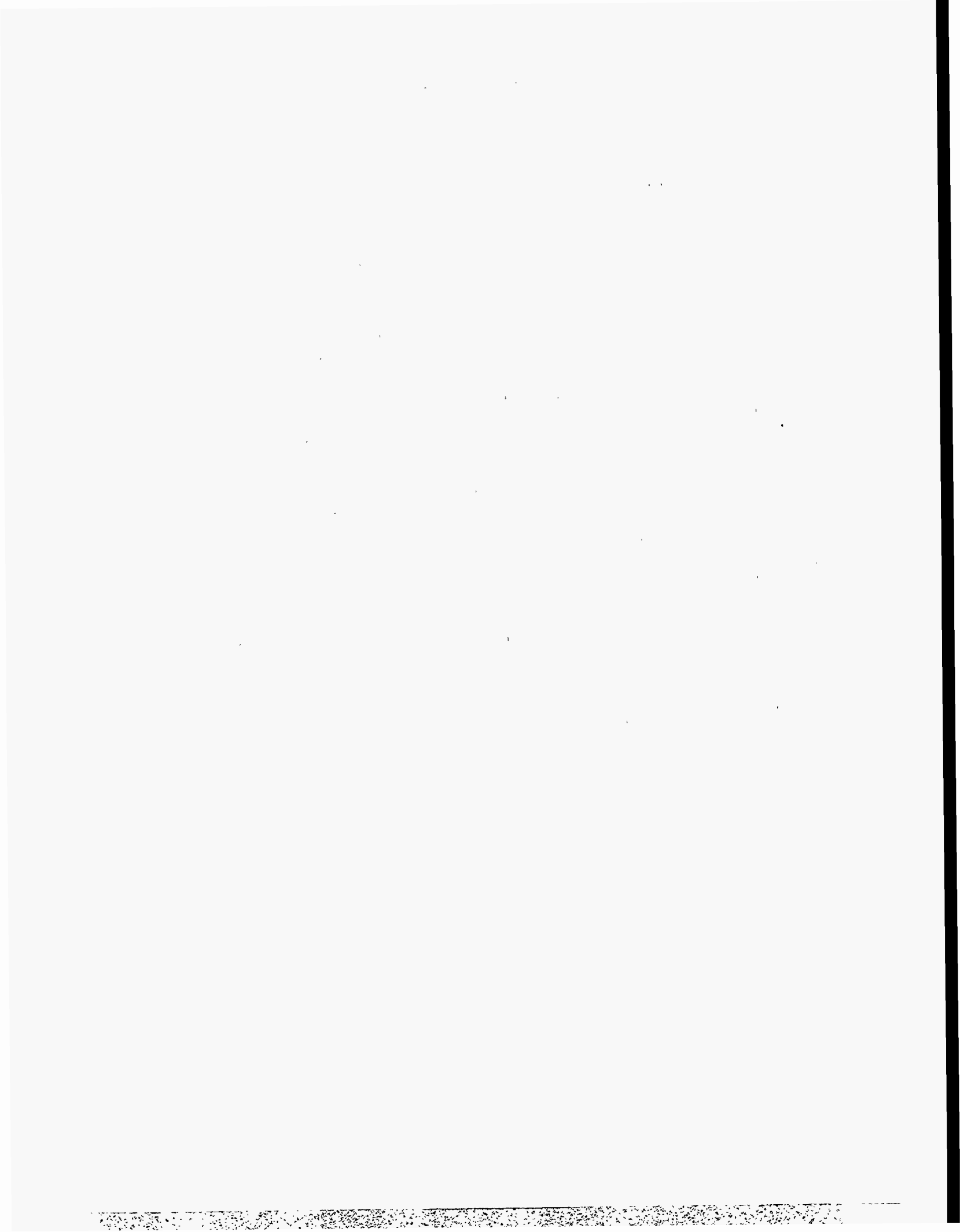

Acknowledgments

We would like to thank R. K. Nanstad for his encouragement and help in the planning of this project. The mechanical testing was conducted by J. J. Henry, Jr., and E. T. Manneschildt. The authors appreciate the helpful reviews of the draft manuscript by F. M. Haggag and R. L. Klueh. We are very grateful for the efforts of J. L. Bishop in the preparation of the manuscript. We also appreciate the technical editing by K. Spence and the final report preparation by Eric White.

The authors are grateful for the financial support of the Heavy-Section Steel Irradiation Program at ORNL by the Office of Nuclear Regulatory Research, U.S. Nuclear Regulatory Commission. This research was supported in part by an appointment to the ORNL Postdoctoral Research Program administered by the Oak Ridge Institute for Science and Education.

Introduction

The possibility of using subsize specimens to monitor the properties of reactor pressure vessel (RPV) steels is receiving increasing attention for light-water reactor (LWR) plant life extension. Annealing of Soviet-built reactors^{1,2} resulted in significant recovery of irradiation embrittlement and the extension of plant life. This suggests that annealing of RPVs might be a very attractive way to extend the plant life for some U.S. LWRs.^{3,4} However, practical implementation of annealing includes some regulatory aspects. One of these is extension of the surveillance program, so that properties of the RPV can be monitored after annealing. Machining subsize specimens from previously tested Charpy surveillance specimens or reconstitution of specimens from broken halves are the most feasible ways to resolve this problem. Additionally, subsize specimens could be used in performance experiments to study the general behavior of RPV steels after reirradiation. Such experiments usually require simultaneous irradiation of a large number of specimens at the same conditions, as well as intermediate annealing of a portion of them after the first cycle of irradiation and after the second reirradiation. Another application for using subsize specimens is also associated with annealing. The subsize specimens can be used to confirm the beneficial effects of vessel annealing by cutting pieces of small volume from the inside surface of the vessel before and after annealing^{5,6} and periodically during continued operation of the annealed vessel. In the last case, this could be an alternative to the standard surveillance program.

The main issue for the feasibility of using subsize Charpy V-notch (CVN) specimens to determine properties of RPV steels is the correlation of transition temperature and upper-shelf energy (USE) between subsize and full-size specimens. This study analyzed different published approaches to the use of subsize CVN specimens. Five different geometries of subsize specimens from 11 material conditions were selected for testing and evaluation. The effects of specimen size and notch dimensions, including depth, angle, and root radius, on the correlation with data from full-size specimens have been studied.

Materials

Four types of RPV steels were studied: American Society for Testing and Materials (ASTM) A 533 grade B class 1 plates (one of them after quenching and tempering at 950°C), specially heat-treated steel with ASTM A 508 class 2 chemical composition, a Russian ring forging 15Kh2MFA, and a submerged-arc weld. All of these RPV steels have been studied previously at Oak Ridge National Laboratory using standard specimens under different tasks of the Heavy-Section Steel Technology (HSST) and Heavy-Section Steel Irradiation (HSSI) Programs. The materials were selected so as to have a relatively wide range of transition temperatures and USEs as measured with standard full-size Charpy specimens, as well as a range of yield strengths. Typically, the properties of many RPV steels in the as-produced state are quite similar. To increase the range of properties, some steels were studied in the quenched-only or quenched-and-tempered conditions. As a result, the USEs varied from 73 to 330 J, the transition temperatures varied from -46 to 58°C, and the yield strengths varied from 410 to 940 MPa. Table 1 lists the types and properties of the different materials.

Specimen Designs

The *Standard Test Method for Notched Bar Impact Testing of Metallic Materials*, ASTM E 23-93a,⁷ allows the use of subsize specimens when the amount of material available does not permit making the standard impact test specimens, but "the results obtained on different sizes of specimens cannot be compared directly." Therefore, the use of subsize specimens recommended by ASTM E 23 requires correlating them with standard specimens. According to ASTM E 23, the length, notch angle, and notch root radius for subsize specimens are the same as for full-size specimens, which restricts the range of possible subsize specimen dimensions. A key feature of subsize specimens for RPV applications is the ability to use halves of broken full-size surveillance specimens. As a result, several attempts have been made to develop subsize impact specimens with a geometry acceptable for nuclear application; see, for example, refs. 6 and 8 through 15. Specimens were varied in all dimensions and are as small as 1 × 1 × 20 mm.^{14,15} However, there are some limitations on the dimensions of subsize specimens for RPV materials.

Table 1. Test matrix and mechanical properties of materials for subsize Charpy specimen evaluation

Material and condition	Upper-shelf energy ^a (J)	DBTT ₄₁ ^a (°C)	Yield strength (MPa)	5 × 5 Type 1 ^b	3.3 × 3.3 Type 2 ^b	5 × 5 Type 3 ^b	3 × 4 Type 4 ^b	5 × 5 Type 5 ^b
A 533 wide plate, LT orientation	330	-43	422	X	X	X	X	
A 533 wide plate, TL orientation	244	-46	410	X	X	X	X	
A 508, as-quenched	115	58	634	X	X	X	X	
A 508, quenched and tempered at 599°C	102	40	697	X	X	X	X	
A 508, quenched and tempered at 677°C	116	18	605	X	X	X	X	
A 508, quenched and tempered at 704°C	164	-32	500	X	X	X	X	
HSST ^c Plate 02, TL orientation, quarter thickness	141	3	432	X	X	X	X	
HSST ^c Plate 02, TL orientation, half thickness	114	15				X		X
HSST ^c Plate 014, quenched and tempered at 950°C	73	-34	940	X	X	X	X	
15Kh2MFA, melt 103672	181	-40	630	X	X	X	X	
HSST ^c weld 72W	136	-28	500	X	X	X	X	X
^a Determined with standard full-size Charpy specimens. DBBT = ductile-ductile transition temperature. ^b X = Twelve to 15 specimens. ^c HSST = Heavy-Section Steel Technology Program.								

First, the specimens should be large enough to be tested on commercially produced equipment in hot-cell conditions. For example, the USE of $1 \times 1 \times 20$ mm specimens could be as low as 0.16 J (ref. 15) for steel with a standard specimen USE equal to 200 J. It would be even smaller for low upper-shelf materials, where the USE on standard specimens could decrease to ~ 70 J due to irradiation. For 1- by 1-mm cross-section specimens, the USE might be less than 0.1 J, and in the transition region, it would be much less than 0.1 J.

ASTM E 23 requires that the specimen be broken within 5 s after removal from the conditioning medium. A reduction of size resulting in a significant increase in the surface area to volume ratio may lead to excessive temperature losses prior to impact.

Another important limitation in decreasing specimen size is the extent of the microstructural inhomogeneities. For example, a study of a special heat of A 508 steel^{16,17} indicated that carbon segregates in slender bands about 0.25 mm wide. Investigation of Midland Nuclear Power Plant RPV weld metal¹⁸ showed that the cross section of individual weld passes could be several millimeters. Testing of full-size Charpy specimens gives average properties of the material, but test results from very small subsize specimens may be dependent on the location of the specimens within the material.

Thus, the lower bound for the cross-sectional dimensions of subsize specimens for irradiated RPV steels may be limited to about 3 mm. The length of a subsize specimen should be no longer than one-half of the standard Charpy specimen (to allow for machining from a broken specimen). Taking into account all the above mentioned considerations, five designs of subsize specimens were selected for the present study (see Figures 1 and 2). The type 1 specimen has a length of 25.4 mm, 5- by 5-mm cross section, with a 30° notch 0.8 mm deep and a root radius of 0.08 mm. Two type 1 specimens could be machined from one broken full-size Charpy specimen. The type 2 specimen has a length of 25.4 mm, 3.33- by 3.33-mm cross section, with a 30° notch 0.5 mm deep and a root radius of 0.08 mm. Eight type 2 specimens could be machined from one broken full-size Charpy specimen. One advantage of choosing types 1 and 2 specimens is the accumulated experience of using these subsize specimens in the United States^{12,19-23} and Japan^{14,15,24} for studies of fusion reactor materials. The type 3 specimen has a length of 27 mm, 5- by 5-mm cross section, with a 45° notch 1 mm deep and a root radius of 0.25 mm. This type of subsize specimen has exactly the same geometry as the smallest ASTM E 23 subsize specimen but is half as long. Two type 3 specimens could be machined from one broken full-size Charpy specimen. Experience with this type of subsize specimen has been accumulated in Russia²⁶ for RPV steels. The type 4 specimen has a length of 26 mm, 3- by 4-mm cross section, with a 60° notch 1 mm deep and a root radius of 0.1 mm. Up to 12 type 4 specimens could be machined from one broken full-size Charpy specimen. Experience with this type of subsize specimen has been accumulated in Europe^{5,11,25} and Russia⁶ for different low-alloy steels including RPV steels. The type 5 specimen has a length of 55 mm, 5- by 5-mm cross section, with a 45° notch 1 mm deep and a root radius of 0.25 mm. This type is the smallest subsize specimen recommended by ASTM E 23. A major disadvantage of this design is that it is not possible to make this type of subsize specimen from a broken full-size Charpy specimen. Nevertheless, specimens of this design were studied for two materials. Details of notch differences are shown in Figure 3.

Testing Procedure

All subsize specimens were tested on a specially modified pendulum-type instrumented impact machine.¹² The modified anvils supported the types 1 and 3 subsize specimens so that their relative position with respect to the pendulum was the same as that for the full-size specimen; that is, the center of percussion of the pendulum was maintained at the center of the point of impact, with the specimen just touching the striker with the pendulum hanging free. The types 2 and 4 subsize specimens were tested using the same anvils, resulting in the center of the point of impact being slightly lower and further ahead than the center of percussion of the pendulum when hanging free. Similarly, for type 5 subsize specimens tested using the full-size anvils, this offset was 2.5 mm. These offsets were estimated to produce errors of less than 0.1 J (ref. 26). The span (minimum distance between the radii of the anvils) was 20 mm for types 1, 2, and 3 specimens and 22 mm for the type 4 specimen. The thickness of the ASTM E 23 striker was reduced to 4 mm to allow clearance of the specimen halves between the anvils. The radii of the striker and the anvils, however, were maintained in accordance with ASTM E 23. The type 5 specimens were tested at the full capacity of the machine [407 J (300 ft-lb)] and an impact velocity of 5.5 m/s (18 ft/s). All other subsize specimens were tested at a lower potential energy [69 J (51 ft-lb)], with a corresponding reduction of the impact velocity to 2.25 m/s (7.4 ft/s).

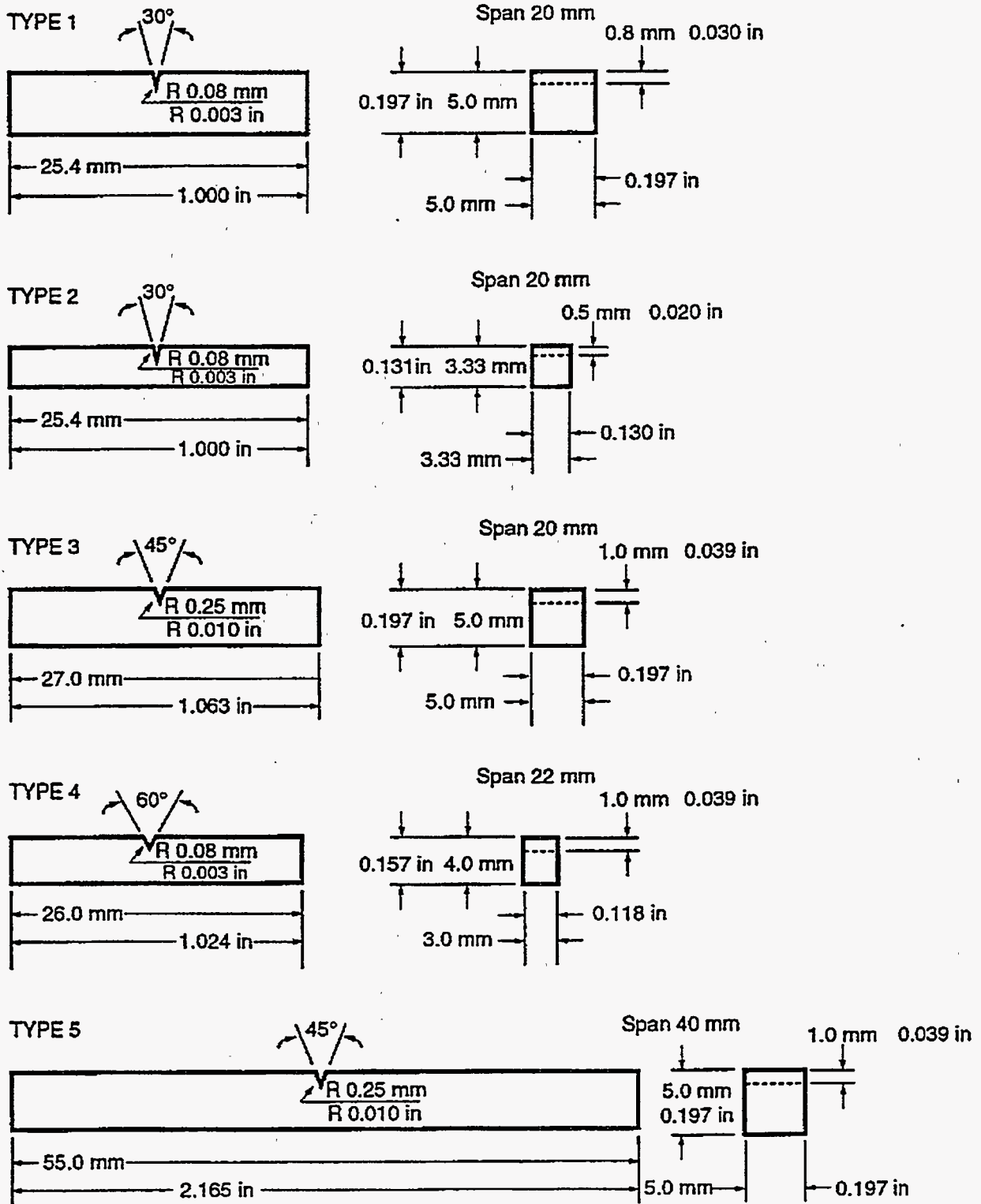

Figure 1. Dimensions of subspecimens used in this study.

TYPE 1

5.0 x 5.0 x 25.4mm
30° notch, 0.8mm depth
0.08mm root radius



TYPE 2

3.3 x 3.3 x 25.4mm
30° notch, 0.5mm depth
0.08mm root radius



TYPE 3

5.0 x 5.0 x 27.0mm
45° notch, 1.0mm depth
0.25mm root radius



TYPE 4

3.0 x 4.0 x 26.0mm
60° notch, 1.0mm depth
0.1mm root radius



FULL SIZE

10.0 x 10.0 x 55.0mm
45° notch, 2.0mm depth
0.25mm root radius



Figure 2. Full-size and subsized specimens used in this study.

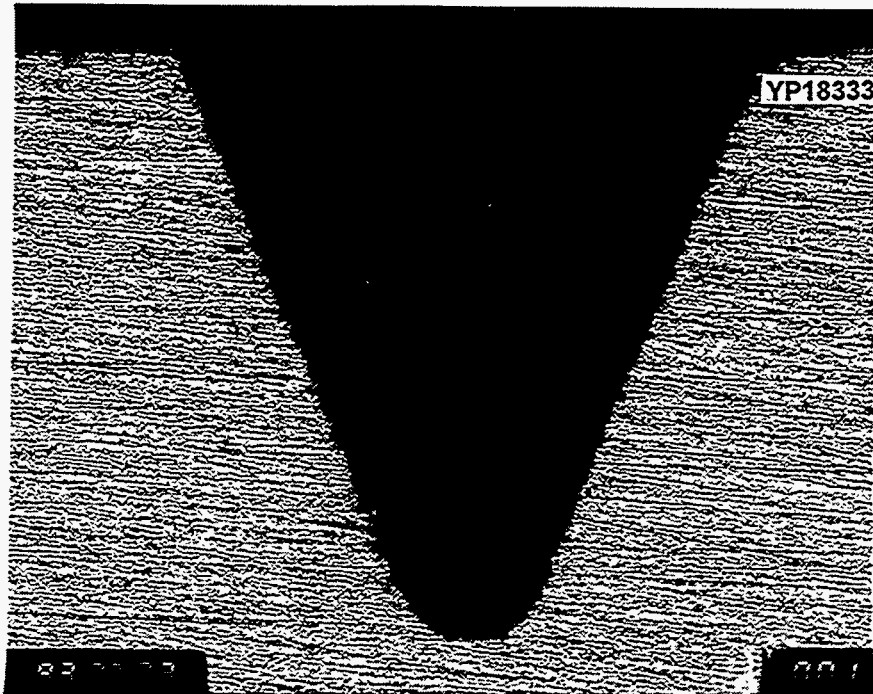

(a)

500 μm

40X

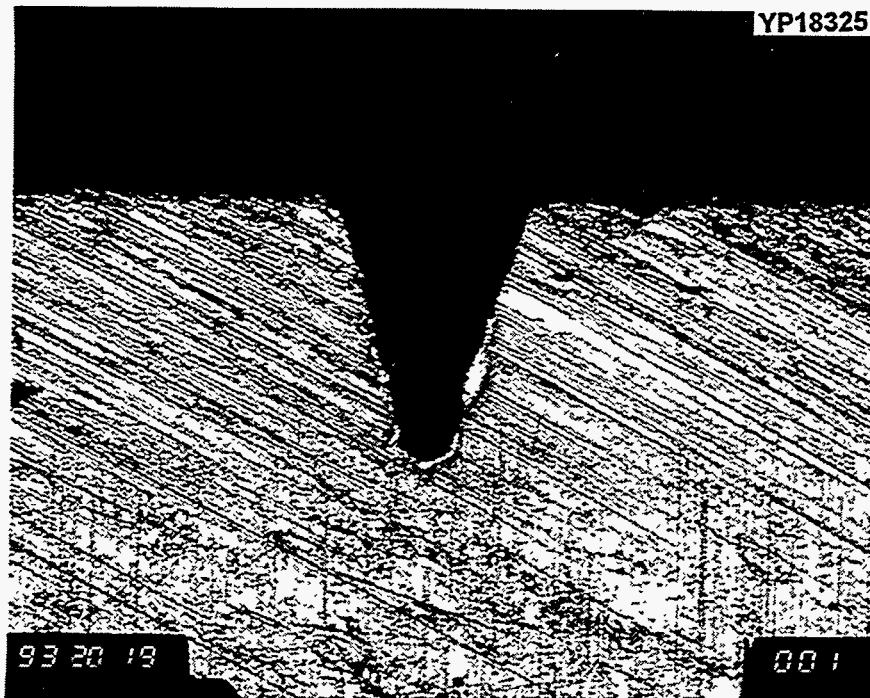

(b)

500 μm

40X

Figure 3. Comparison of notch dimensions of full-size and subsize specimens used in this work: (a) full size, (b) type 1, (c) type 2, (d) type 3, and (e) type 4.

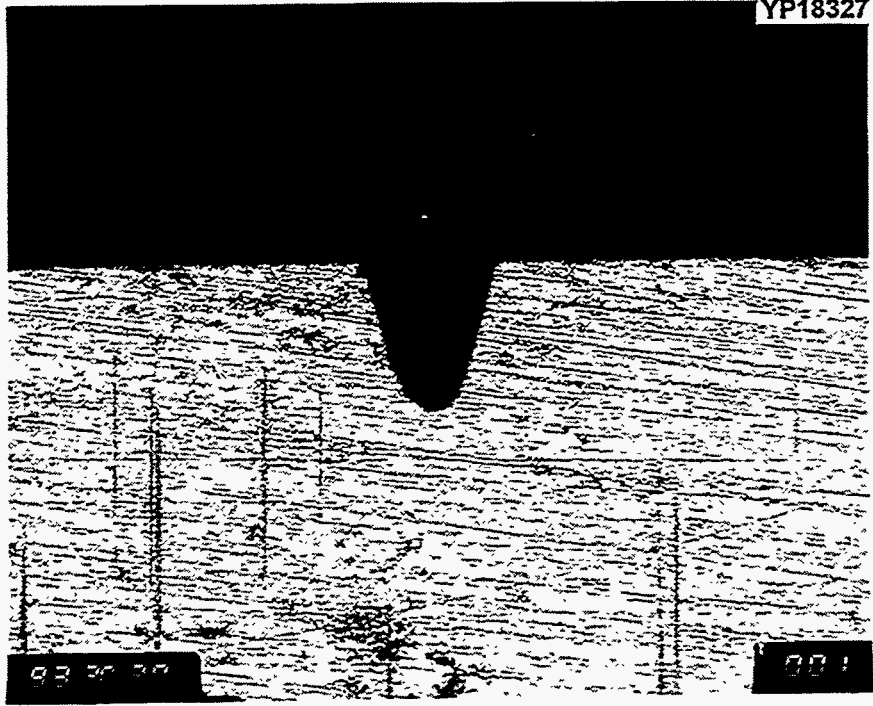

(c)

500 μ m

40X

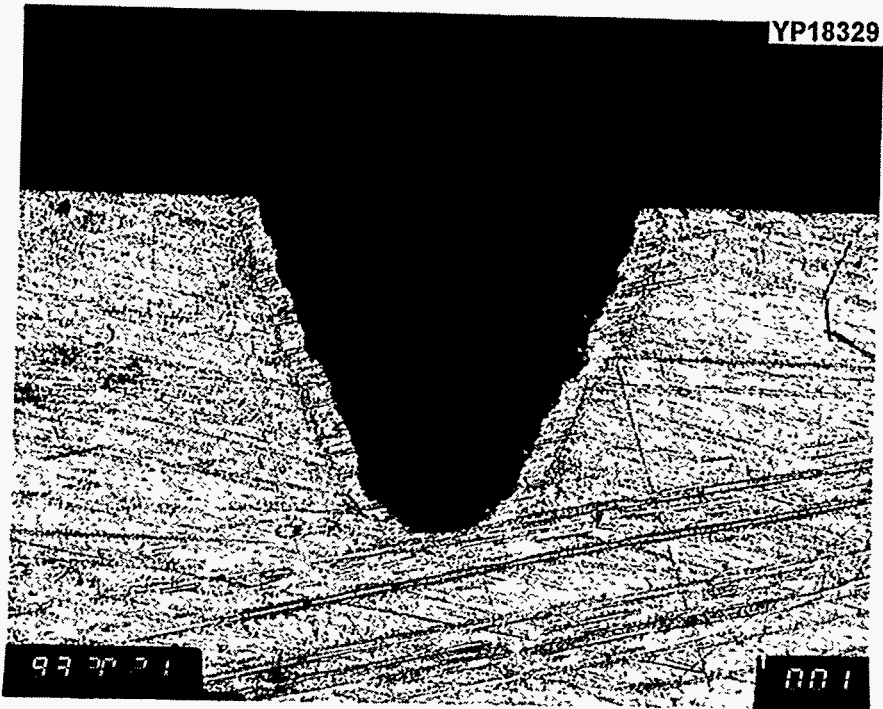

(d)

500 μ m

40X

Figure 3 (continued)

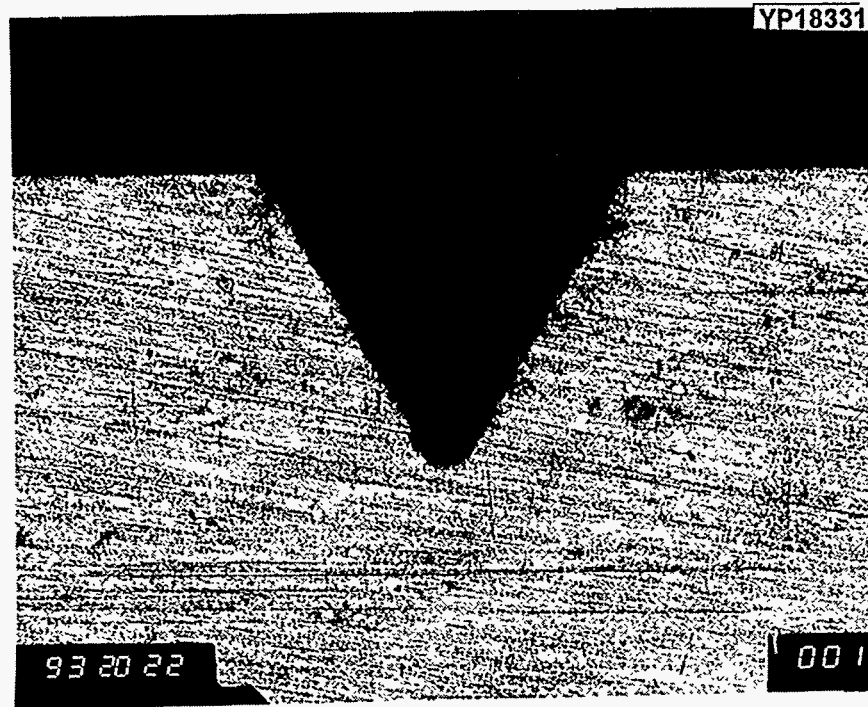

(e)

500 μ m

40X

Figure 3 (continued)

The impact data for each material condition and specimen type were fitted with a hyperbolic tangent function to obtain transition temperatures and USEs:

$$Y = \frac{US + LS}{2} + \frac{US - LS}{2} \cdot \tanh \left[\frac{T - T_{MT}}{C} \right], \quad (1)$$

where T is test temperature (in $^{\circ}\text{C}$), and US , LS , T_{MT} , and C are fitting parameters. Parameters US and LS can be upper- and lower-shelf values of energy, lateral expansion, or percent shear; T_{MT} is the temperature at the middle of the transition range (in $^{\circ}\text{C}$), and C is half of the transition zone width (in $^{\circ}\text{C}$). All hyperbolic tangent analyses for full-size specimens were conducted with the lower shelves fixed at 2.7 J and 0.061 mm for energy and lateral expansion, respectively. All hyperbolic tangent analyses for subsize specimens were conducted with the lower shelves fixed at 0.1 J and 0.0 mm for energy and lateral expansion, respectively. Upper and lower shelves of percent shear fracture were always fixed at 100 and 0%, respectively. Appendices A through K contain the Charpy impact results.

Effects of Specimen Dimensions

One objective of the study was to clarify the effects of specimen dimensions on the Charpy impact results. Analyses of these effects will be used in the development of a methodology for estimation of the ductile-to-brittle transition temperature (DBTT) and USE of full-size specimens using test data from subsize specimens.

The CVN dimensions—depth, angle, and root radius—play an important role in the transition behavior due to changes in the stress concentration under the notch. Most obvious is the effect of notch depth (a) on the USE. The sensitivity of USE to the V-notch depth was studied on type 3 specimens of HSST Plate 02 (see Figure 4). One set of specimens was made with a notch 1.7 mm deep (0.065 in.), and a second set was made with a notch 0.8 mm deep (0.030 in.). The results were compared with results for the common 1.0-mm (0.039-in.) notch depth.

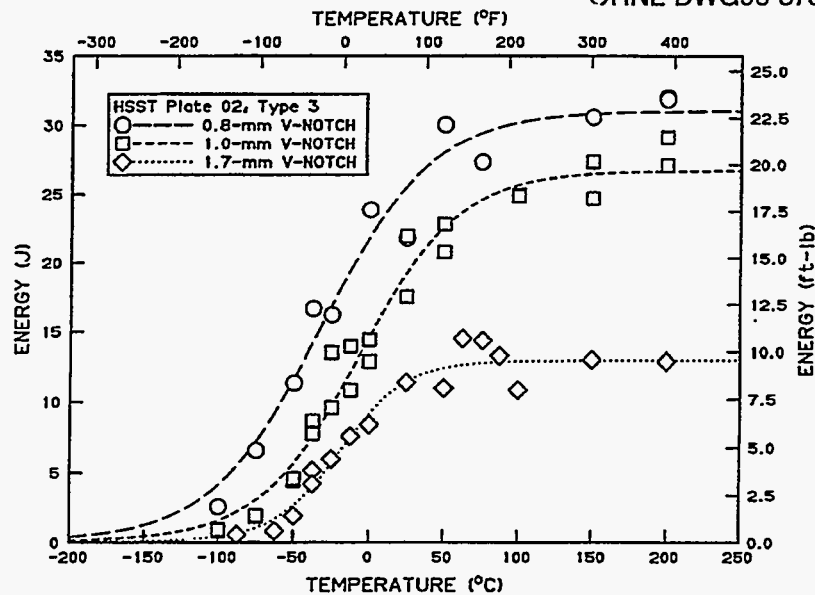

Figure 4. Absorbed energy versus test temperature for type 3 specimens from HSST Plate 02, quarter-thickness location, with 0.8-, 1.0-, and 1.7-mm V-notch depths.

Increasing the depth significantly reduced the USE (from 31 J for $a = 0.8$ mm to 13 J for $a = 1.7$ mm). The temperatures at the middle of the transition region, T_{MT} , were -31 , -6 , and -19°C for specimens with notch depths of 0.8, 1.0, and 1.7 mm, respectively. These changes in transition temperature are mainly due to changes in the USE rather than due to the effect of the notch depth on the transition behavior.

The effect of the notch root radius can be seen when comparing data from HSST Plate 02 type 3 specimens with 0.25- and 0.10-mm notch radii (see Figure 5). For this particular experiment, specimens of 0.8-mm notch depth were used. Sharpening of the notch led to an increase of transition temperature by $\sim 20^{\circ}\text{C}$ and a decrease of the USE by ~ 5 J. These data agree with other observations of notch dimension effects on impact data.^{15,26}

The effect of notch angle was studied on two sets of HSST Plate 02 type 1 specimens with 45 and 30° angles (see Figure 6). This change in the notch angle did not result in any effect on transition temperature or USE.

Another parameter is the distance between the anvil supports (span). Figure 7 shows Charpy curves of HSST Plate 02 type 4 specimens tested with spans of 22 and 20 mm. No difference was observed in the transition region. Data from specimens with the shorter span possibly indicated a slightly higher energy on the upper shelf, but this difference could be due to scatter in the data. However, there is a mechanism that may explain higher energies for specimens tested with the shorter span (20 mm). The smaller subsized specimens tested on the upper shelf usually do not fracture completely, but bend around the tup until they are forced out past the anvils. With a shorter span, the specimens must be bent further and scraped against the anvils for a longer time until they can be pushed out. This will result in a longer tail on the end of the load-deflection curve, which will be reflected in slightly higher absorbed energies, as the data tend to show. In the transition region, the specimens do break completely, so no extra force is required to push the specimen through the anvils. In this case, no effect of span would be expected, and no effect is observed (see Figure 7).

Another example of the effect of span on impact properties is given by a comparison of data from types 3 and 5 subsized specimens. The only difference between these specimens is that type 3 specimens have one-half the span of type 5. The impact curves of types 3 and 5 specimens of weld 72W are presented in Figure 8. Figure 9 presents

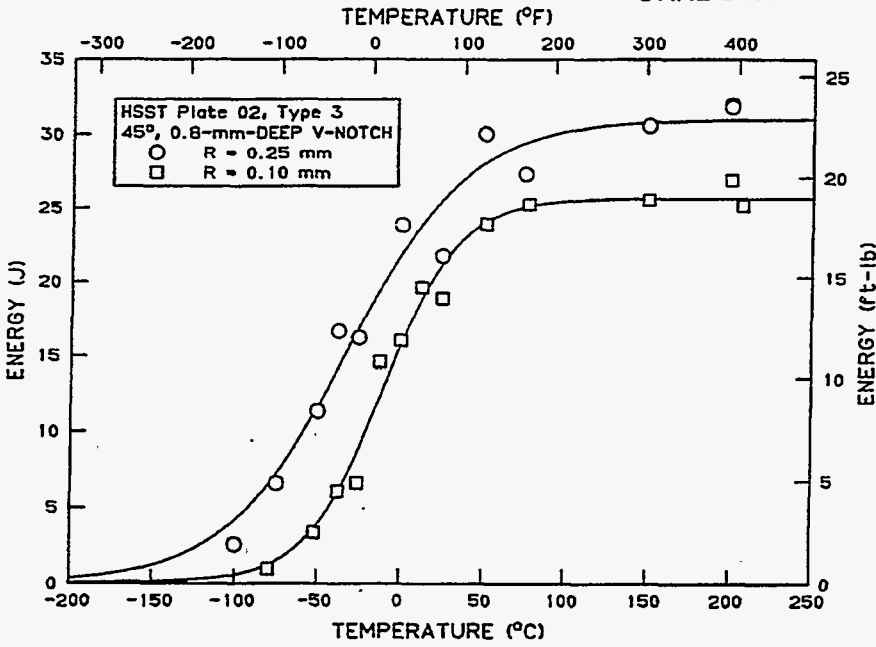

Figure 5. Absorbed energy versus test temperature for type 3 specimens from HSST Plate 02, quarter-thickness location, with 0.25- and 0.10-mm V-notch root radii.

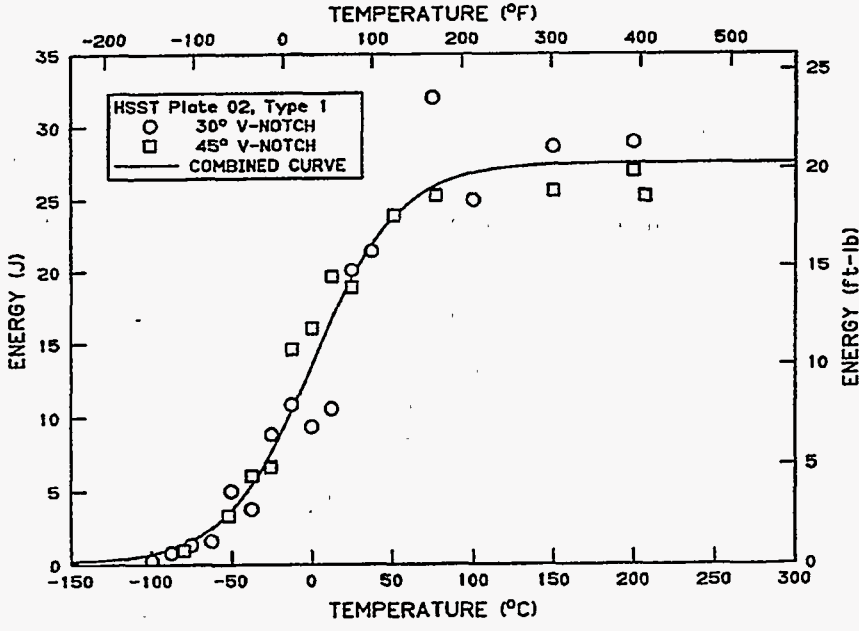

Figure 6. Absorbed energy versus test temperature for type 1 specimens from HSST Plate 02, quarter-thickness location, with 30 and 45° V-notch angles.

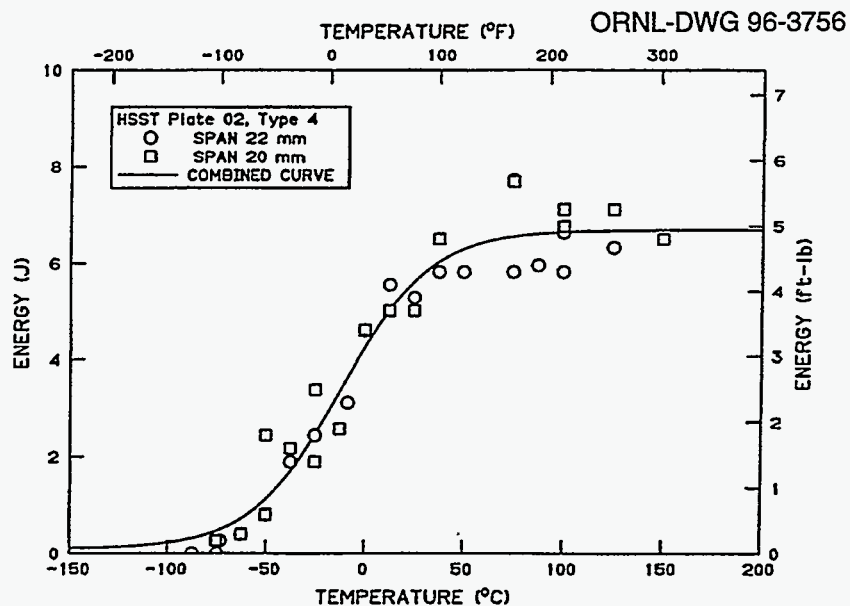

Figure 7. Absorbed energy versus test temperature for type 4 subsized specimens from HSST Plate 02, quarter-thickness location, tested at 22- and 20-mm span.

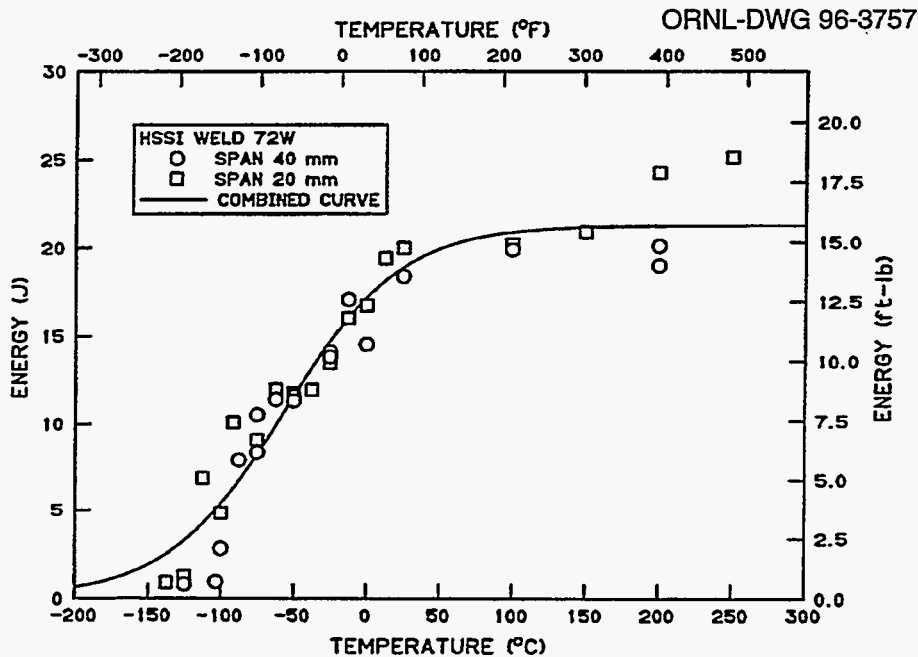

Figure 8. Absorbed energy versus test temperature for types 3 and 5 specimens of weld 72W tested at 40- and 20-mm span.

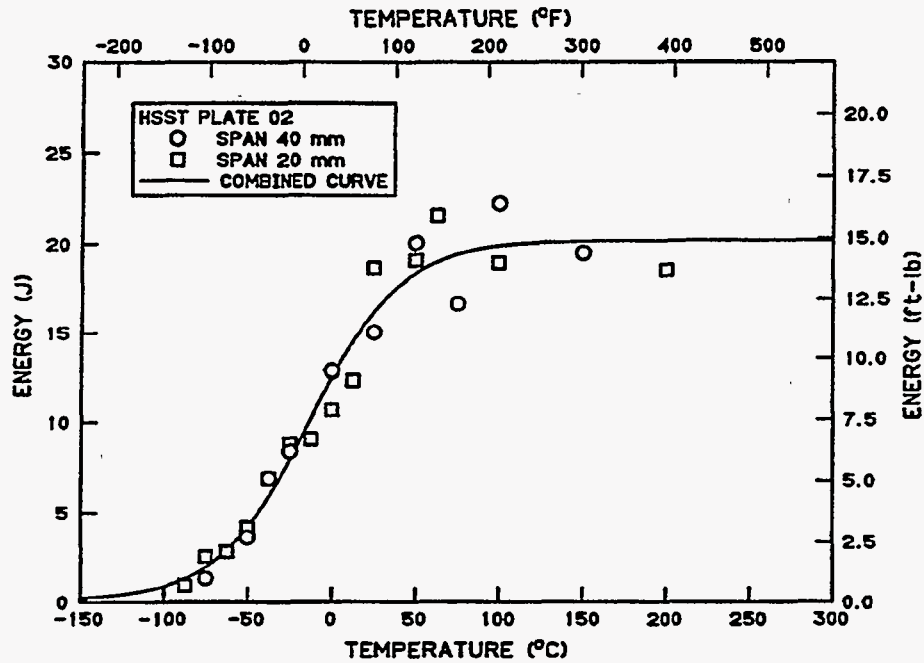

Figure 9. Absorbed energy versus test temperature for types 3 and 5 specimens of HSST Plate 02, half-thickness location, tested at 40- and 20-mm span.

the impact curves of types 5 and 3 specimens of HSST Plate 02. The type 5 specimens were cut from the half-thickness region in the plate, whereas the full-size Charpy specimens were taken from both the quarter- and half-thickness locations. The impact properties were slightly different at these two depths in the plate (see Table 1). The type 3 specimens were cut from the broken halves of tested type 5 specimens. In both examples in Figures 8 and 9, these results did not show any difference between types 3 and 5 specimens. These materials have fairly low USEs, and the 5- by 5-mm specimens break even on the upper shelf, so no effect of span is observed.

Five type 4 specimens of weld 72W were tested at an impact velocity of 5.5 m/s (18 ft/s), while 13 were tested at 2.25 m/s (7.4 ft/s), the usual impact velocity for subsize specimens in this study (see Figure 10). The same experiment was repeated on two sets of HSST Plate 02 type 3 specimens. Figure 11 presents Charpy data for these sets with 12 specimens in each. The results in Figures 10 and 11 show no sensitivity of impact properties to the increase of impact velocity from 2.25 to 5.5 m/s.

Correlation of Absorbed Energy Between Full-Size and Subsize Specimens

The absence of standardized procedures for subsize specimen testing results in different approaches to correlation of data between subsize and standard specimens. Generally, existing correlations of USE data can be divided into two approaches. One method widely used in Europe^{5,6,11,25} consists of establishing an empirical ratio of the USE of full-size to USE of subsize ($USE_{subsize}$) specimens based on large numbers of tests. The second approach, often used by North American^{12,13,19-23,27} and Japanese^{14,15,24} researchers, consists of correlation of the ratio between the USE of full-size and subsize specimens with the ratio of different geometrical parameters of full-size and subsize specimens:

$$\frac{USE_{full\ size}}{USE_{subsize}} = \frac{f(\text{geometric parameters})_{full\ size}}{f(\text{geometric parameters})_{subsize}} \quad (2)$$

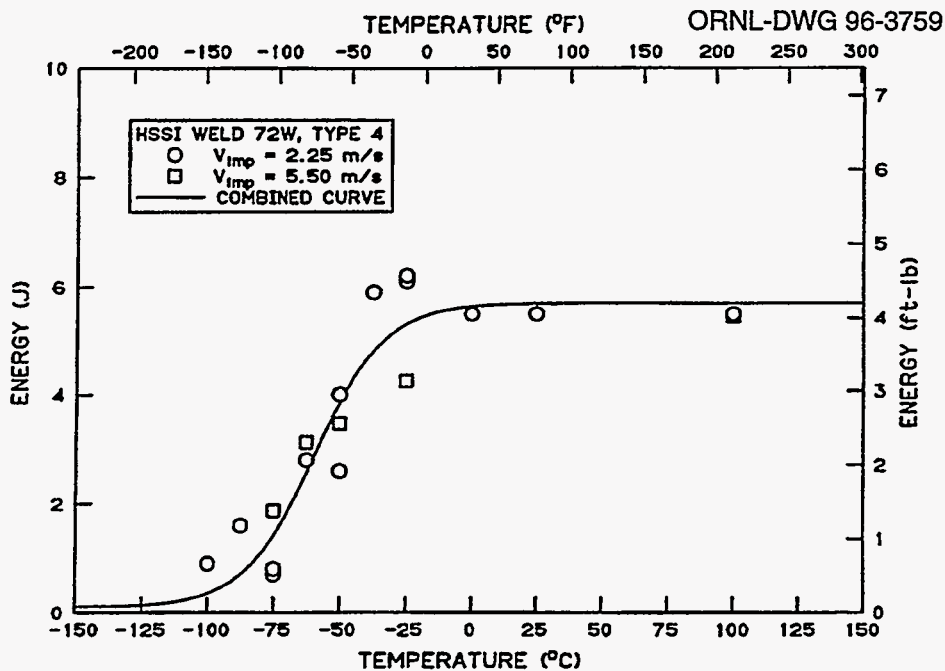

Figure 10. Absorbed energy versus test temperature for type 4 specimens of weld 72W tested at impact velocities of 5.5 and 2.25 m/s.

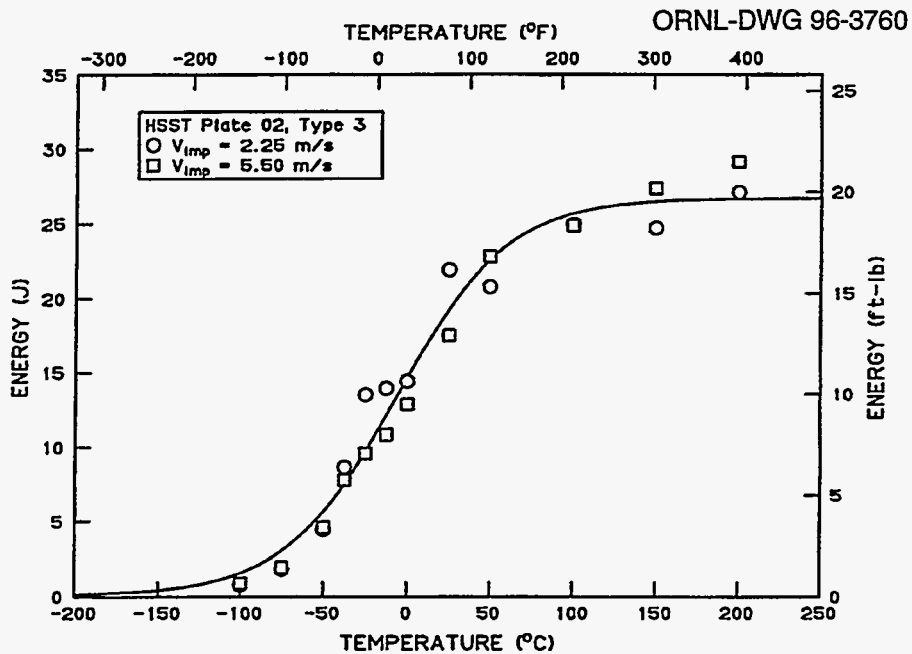

Figure 11. Absorbed energy versus test temperature for type 3 specimens of HSST Plate 02, quarter-thickness location, tested at impact velocities of 5.5 and 2.25 m/s.

In other words, the ratio of geometrical parameters can be used as a normalization factor (NF) to determine USE of full-size specimens based on the results of testing subsize specimens:

$$USE_{full\ size} = NF \times USE_{subsize} \quad (3)$$

The published ratios of geometric parameters of full-size to subsize specimens or NFs are described below.

Corwin et al.^{12,23} compared two NFs. The first factor was equal to the ratio of the fracture area (Bb) of the full-size specimen to that of the subsize specimen, where B is the width and b is the depth of the ligament below the notch of the specimen (see Figure 12 and Table 2). The second was equal to the ratio of the nominal fracture volume (FV) [(Bb)^{3/2}] of the full-size to the subsize specimen. It was shown that use of the NF (Bb)^{3/2} gave good correspondence. Normalization by Bb gave poor agreement for USE data.

Lucas et al.^{13,27} also used an NF equal to the ratio of the FV of full-size to subsize specimens, but expressed the nominal FV as Bb².

Louden et al.²¹ suggested an NF equal to the ratio of Bb²/LK_t of full-size to subsize specimens, where L is the span and K_t is the elastic stress concentration factor,²⁸ which is dependent on ligament size b and notch radius R. The present study has shown (see Figures 8 and 9) that Charpy data, including USE, of specimens tested at spans that differed by a factor of two (20 and 40 mm) did not depend on span. However, the USE depends on ligament size b (see Figure 4) and notch radius R (see Figure 5), which might support using K_t. Nevertheless, it is not clear how an elastic stress concentration factor can be related to behavior on the upper shelf, where fracture is taking place in a ductile manner dominated by plastic strain.

Kumar et al.^{20,22,29} have developed an interesting approach to predict the USE of full-size specimens by using both notched and precracked subsize specimens. They suggest that this allows a separation of the USE into energies for crack initiation and crack propagation. This approach is based on the assumption that the energy for crack initiation normalized by FV of the specimen is equal for full-size and subsize specimens. Energy for crack initiation can be determined from the difference between the USE of notched specimens (USE) and precracked specimens (USE_p), that is:

$$\left[\frac{USE - USE_p}{FV} \right]_{full\ size} = \left[\frac{USE - USE_p}{FV} \right]_{subsize} \quad (4)$$

where FV is equal to Bb². In addition, it was found that the ratio of the USE of notched specimens to the USE of precracked specimens (USE_p) did not depend on specimen size, namely:

$$\left[\frac{USE}{USE_p} \right]_{full\ size} = \left[\frac{USE}{USE_p} \right]_{subsize} \quad (5)$$

Thus, Kumar et al. claimed that knowledge of USE and USE_p of subsize specimens allowed the use of Equations (4) and (5) to determine the USE of full-size specimens. Examination shows, however, that Equations (4) and (5) are dependent and can be transformed into one equation:

$$\left| \frac{USE}{FV} \right|_{full\ size} = \left| \frac{USE}{FV} \right|_{subsize} \quad (6)$$

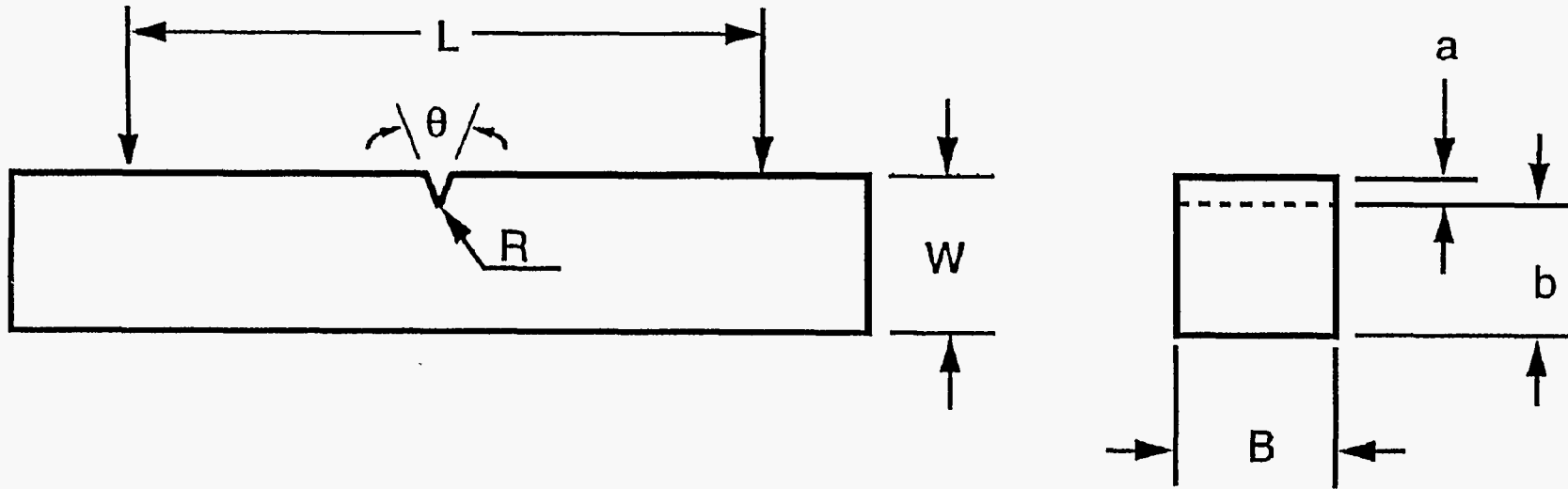

Figure 12. Definition of specimen dimensions.

15

Table 2. Comparison of different normalization factors for upper-shelf energy as ratios of different specimen dimensions

Geometric parameter, G.P.	Bb	Bb^2/LK_t	$(Bb)^{3/2}/LK_t$	Bb^2	$(Bb)^{3/2}$	Bb^2/Q	$(Bb)^{3/2}/Q$	Bb^2/QK_t	$(Bb)^{3/2}/QK_t$
$G.P._{fullsize}/G.P._{type 1}$	3.77	5.63	5.8	7.12	7.33	7.54	7.76	11.9	12.3
$G.P._{fullsize}/G.P._{type 2}$	8.52	15.6	16	24.2	24.8	25.6	26.3	33.1	33.9
$G.P._{fullsize}/G.P._{type 3}$	4	2.8	2.8	8	8	8	8	5.7	5.7
$G.P._{fullsize}/G.P._{type 4}$	8.9	13	14.6	23.7	26.5	22.3	24.9	22.3	24.9

Note: L = span, K_t = elastic stress concentration factor, and Q = plastic stress concentration factor.

NUREG/CR-6379

which is the same as Lucas et al.^{13,27} proposed previously for a nominal FV of Bb^2 and does not require testing of precracked specimens.

Kayano et al.¹⁴ have proposed an NF that incorporates not only FV but elastic (K) and plastic (Q) stress concentration factors as well. For the plastic stress concentration factor, the following expression based on slip-line field theory for a notched specimen³⁰ was used:

$$Q = 1 + \frac{\pi - \theta}{2}, \quad (7)$$

where θ is the notch angle in radians. Some uncertainty remains as to the exact value of Q in CVN testing.^{31,32} Slip-line field theory also assumes elastic-perfectly plastic behavior and neglects work hardening, which is clearly not a valid assumption for most materials. In addition, slip-line field theory can only be used when fracture occurs exactly at the point of general yielding. This will apply only at one specific temperature for a given material, not over the whole transition regime. In any case, implementation of Q, as in Eq. (7), includes the effect of notch angle on USE. However, the results of the present study did not show such a dependence over the limited range of notch angles examined.

In the present work, different NFs described above, as well as modifications by the authors, were implemented in the analysis of the data (see Table 2). Table 3 summarizes the results of measured USE values for full-size and subsize specimens of the steels investigated in the present study. For all types of subsize specimens, a linear dependence between the USE of full-size and subsize specimens is observed except for two points with USEs of full-size specimens higher than 200 J. Values of USE higher than 200 J for full-size specimens require special consideration. Specimens tested in the upper-shelf region show large amounts of plastic deformation at the support points. These features are associated with the specimen squeezing between the anvils. All interactions between the specimen and the anvils will require additional energy as reflected by the absorbed energy value.^{33,34} Specimens with high USE values will have significant amounts of energy associated with the anvil interactions in addition to the fracture process at the notch. Further investigations need to be performed to analyze these data. For the purposes of this study, analysis of USE data was limited to data below 200 J for full-size specimens.

Figures 13 through 16 present the correlation observed for the USE from full-size specimens to the USE from subsize specimen types 1 through 4 as well as ratios of $USE_{full\ size}$ to $USE_{subsize}$ for each type of subsize specimen. Comparison of the ratios obtained with the NFs in Table 2 shows that no single factor can be considered as universal for any specimen geometry, although an NF based on the FV of specimens, namely $(Bb^2)_{full\ size}/(Bb^2)_{subsize}$, gives the closest estimation for each geometry, but these estimations are slightly higher than empirical ratios for each specimen geometry. An implementation of elastic or plastic stress concentration factors did not improve the correspondence. Based on this observation, a decision was made to use the obtained empirical ratios (see Figures 13-16) as USE normalization factors (NF_{USE}) for each specific geometry. There is no obvious effect of the yield strength on the empirical ratios of USEs, as Figures 17 through 20 show.

Since no single known existing correlation procedure would work for data from different subsize specimens, a new correlation was developed. It was assumed that the fracture process could be partitioned into low-energy brittle and high-energy ductile modes and that different correlation procedures should be applied to each component of the fracture process. On the lower shelf where fracture occurs by a low-energy cleavage mechanism, it is reasonable to assume a constant value of absorbed energy per unit of fracture surface area or:

$$\left[\frac{LSE}{Bb} \right]_{full\ size} = \left[\frac{LSE}{Bb} \right]_{subsize}, \quad (8)$$

Table 3. Upper-shelf energies obtained for materials for subsize Charpy specimen evaluation

Material	USE _{full size} (J)	USE _{type 1} (J)	$\frac{USE_{full\ size}}{USE_{type\ 1}}$	USE _{type 2} (J)	$\frac{USE_{full\ size}}{USE_{type\ 2}}$	USE _{type 3} (J)	$\frac{USE_{full\ size}}{USE_{type\ 3}}$	USE _{type 4} (J)	$\frac{USE_{full\ size}}{USE_{type\ 4}}$
A 533 wide plate, LT orientation	330	34.6	9.5	8.6	38.4	28.4	11.6	7.7	42.9
A 533 wide plate, TL orientation	244	34.3	7.1	8.9	27.4	35.9	6.8	7.2	33.9
A 508, as quenched	115	21.6	5.3	6.1	18.9	17.6	6.5	5.5	20.9
A 508, quenched and tempered at 599°C	102	21.1	4.8	5.3	19.2	15.0	6.8	5.1	20.0
A 508, quenched and tempered at 677°C	116	26.2	4.4	6.8	17.1	17.2	6.7	6.5	17.8
A 508, quenched and tempered at 704°C	164	37.3	4.4	9.3	17.6	24.6	6.7	7.5	21.9
HSST ^a Plate 02, TL orientation, quarter thickness	141	29.3	4.8	6.7	21.0	26.7	5.3	6.3	29.4
HSST ^a Plate 02, TL orientation, half thickness	114					20.3	5.6		
HSST ^a Plate 014, quenched and tempered at 950°C	73	15.1	4.8	5.6	13.0	13.9	5.3	4.5	16.2
15Kh2MFA, melt 103672	181	29.2	6.2	8.3	21.8	24.5	7.4	7.8	23.2
HSSI ^b weld 72W	136	23.7	5.7	7.7	17.7	22.5	6.0	5.9	23.1

^aHSST = Heavy-Section Steel Technology Program.

^bHSSI = Heavy-Section Steel Irradiation Program.

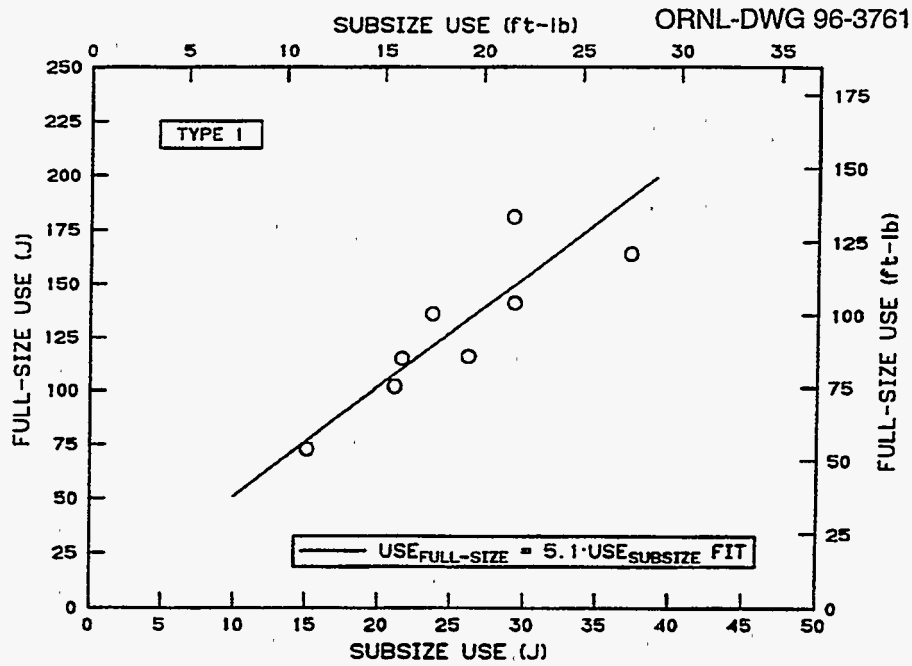

Figure 13. Correlation of upper-shelf energies of full-size and type 1 subsize specimens.

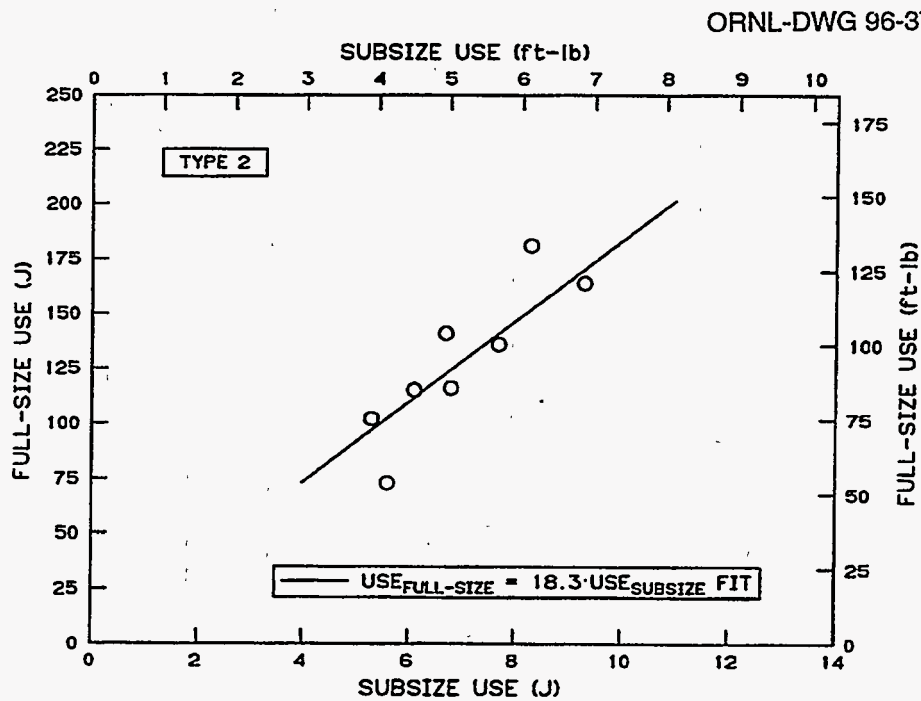

Figure 14. Correlation of upper-shelf energies of full-size and type 2 subsize specimens.

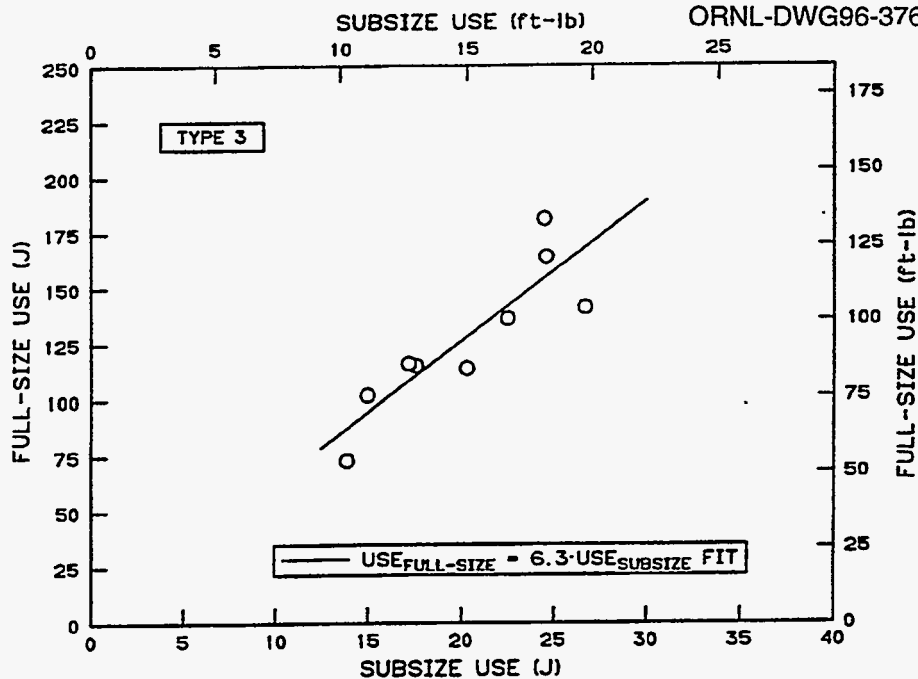

Figure 15. Correlation of upper-shelf energies of full-size and type 3 subsize specimens.

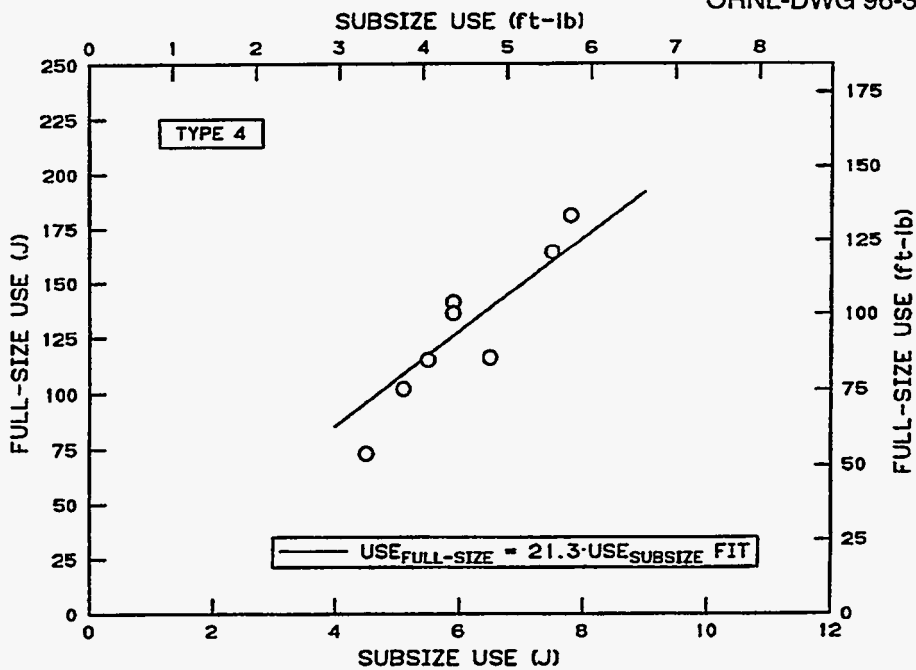

Figure 16. Correlation of upper-shelf energies of full-size and type 4 subsize specimens.

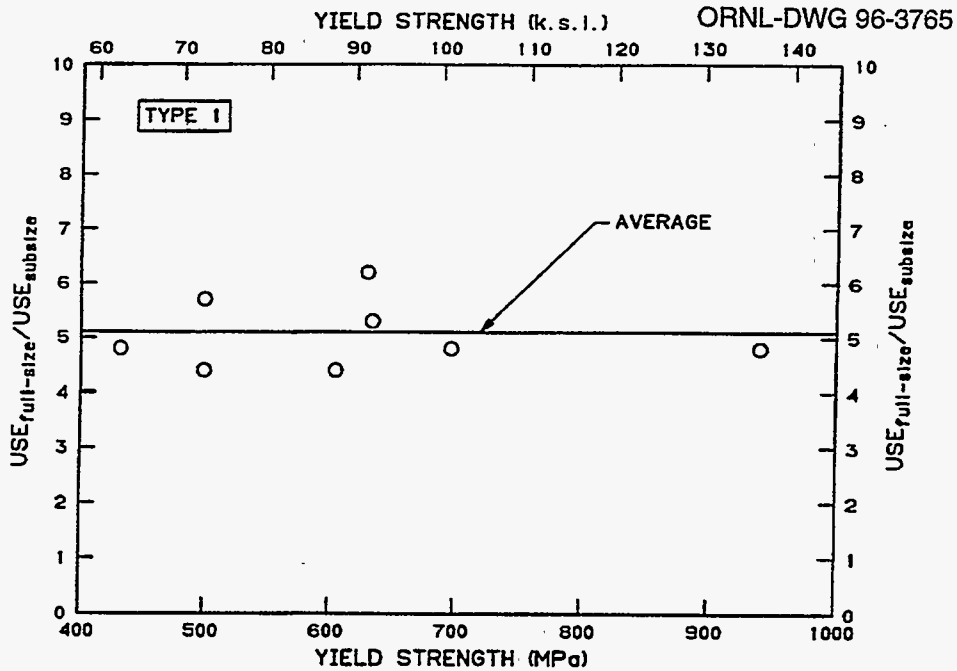

Figure 17. The ratio of upper-shelf energy (USE) of full-size specimens to USE of type 1 specimens as a function of yield strength.

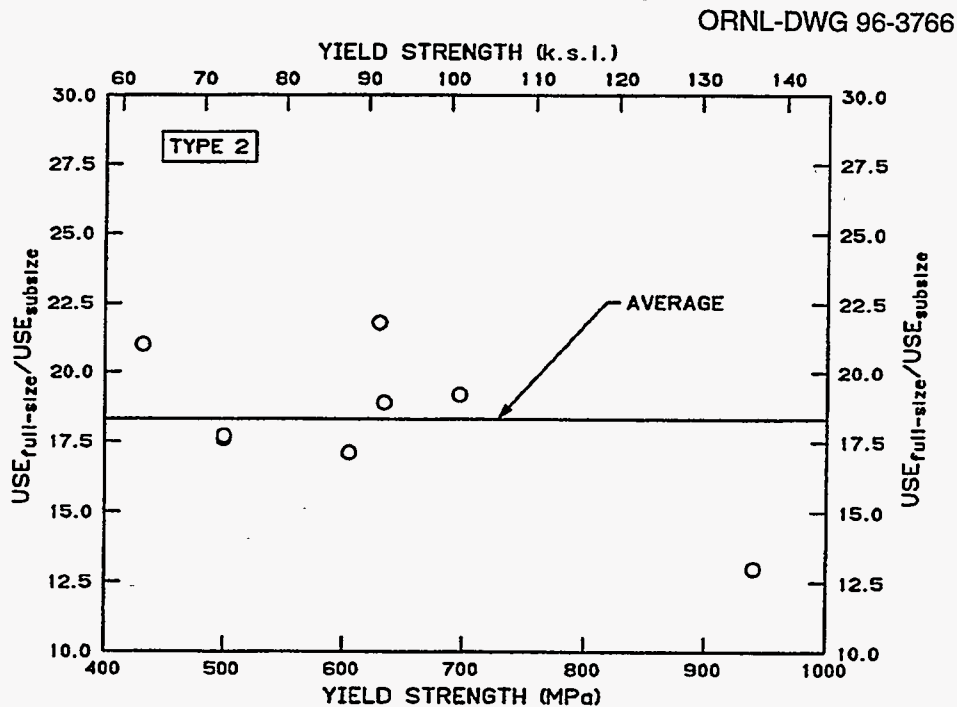

Figure 18. The ratio of upper-shelf energy (USE) of full-size specimens to USE of type 2 specimens as a function of yield strength.

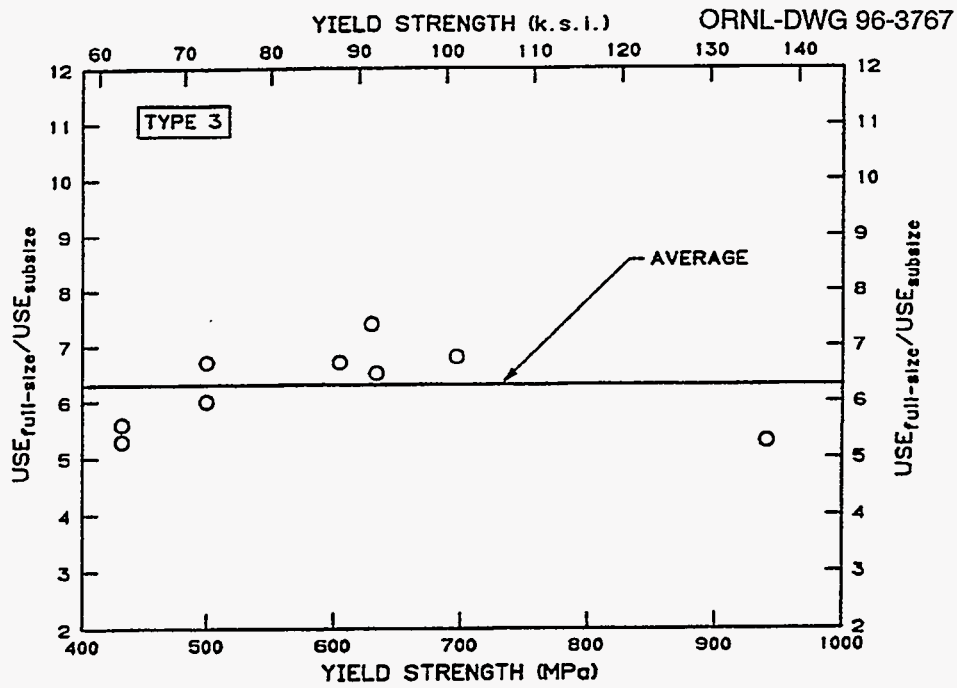

Figure 19. The ratio of upper-shelf energy (USE) of full-size specimens to USE of type 3 specimens as a function of yield strength.

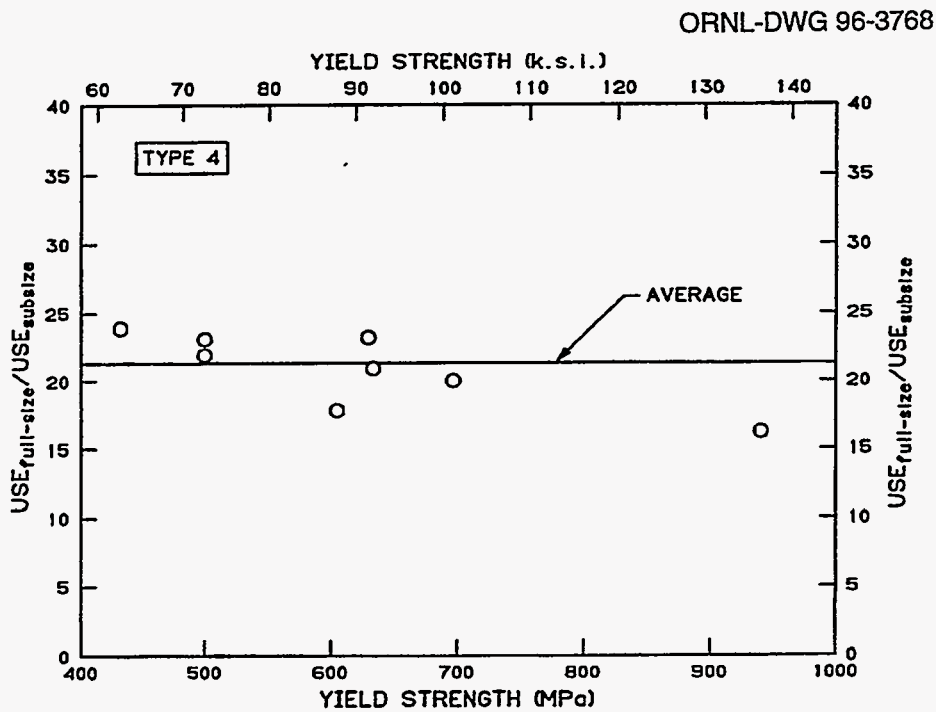

Figure 20. The ratio of upper-shelf energy (USE) of full-size specimens to USE of type 4 specimens as a function of yield strength.

and thus

$$LSE_{full\ size} = NF_{brittle} \times LSE_{subsize}, \quad (9)$$

where

$$NF_{brittle} = \frac{(Bb)_{full\ size}}{(Bb)_{subsize}}. \quad (10)$$

In the transition region there is a competition between brittle and ductile fracture. It is assumed that the percent of shear on the fracture surface can be used as a measure of the amount of ductile fracture in the transition region.

Based on these considerations, the following expression is proposed for normalizing the absorbed energy (E) of subsize specimens:

$$E = E_{subsize} \times \left[NF_{brittle} \frac{100 - SHEAR}{100} + NF_{ductile} \frac{SHEAR}{100} \right], \quad (11)$$

where $NF_{brittle}$ is a normalization factor for the brittle mode of fracture from Equation (10) and is equal to 3.77, 8.52, 4.00, and 8.90 for types 1, 2, 3, and 4 subsize specimens, respectively. $NF_{ductile}$ is a normalization factor for the ductile mode of fracture and is equal to 5.1, 18.3, 6.3, and 21.3 for types 1, 2, 3, and 4 subsize specimens, respectively (see Figures 13 through 16). SHEAR is the percent of shear fracture on the fracture surface measured, in general, visually. In some cases, fracture surfaces of broken subsize specimens were difficult to interpret. In these cases, the procedure proposed by Nanstad and Sokolov³⁴ for estimation of shear fracture from analysis of instrumented impact traces of full-size specimens was used:

$$\% \text{ SHEAR} = \left[1 - \frac{F_{iu} - F_a}{0.5 (F_{gy} + F_m)} \right] \times 100, \quad (12)$$

where F_u , F_a , F_{gy} , and F_m are characteristic points on the load versus displacement trace as shown in Figure 21. It was assumed that the same approach could be used for subsize equations.

Visual determination of the percent of shear fracture requires an interpretation of the appearance of the fracture surface, a process that is subjective and may vary from person to person. This variability may lead to some uncertainty in values of the transition temperature determined with the normalization process in Equation (11). To estimate how serious a problem this might be, data from HSST Plate 02 type 3 specimens were examined. The original data were normalized and analyzed to determine the transition temperatures at energy levels of 41 and 68 J (T_{41J} and T_{68J} , respectively). Then the percent shear data were modified, first by adding 10% to each data point, and then by subtracting 10% from each data point. The lower- and upper-shelf levels were kept at 0 and 100%, respectively, in both cases. The energy levels from the subsize specimens were then normalized with the

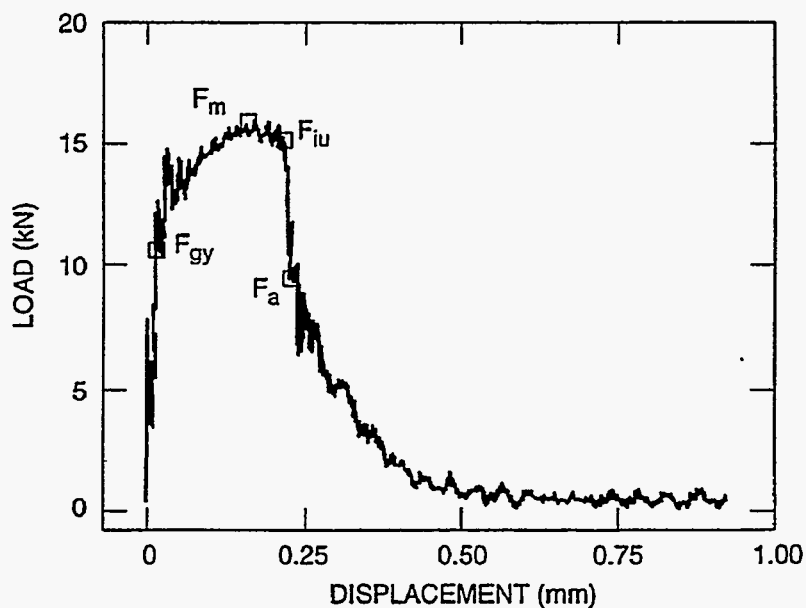

Figure 21. Load versus displacement record showing the definitions of the various load points.

Table 4. Effects of changes in percent shear on values of transition temperatures at 41 and 68 J for normalized data from type 3 specimens of HSST Plate 02

	Transition temperature (°C)		
	As-measured shear ^a	As-measured + 10% ^b	As-measured - 10% ^c
T _{41J}	-28	-30	-26
T _{68J}	-2	-5	1

^aNormalization performed with as-measured percent shear.
^bNormalization performed with percent shear +10%.
^cNormalization performed with percent shear -10%.

altered shear values, in both cases. The results of these changes in the shear values are shown in Table 4. Changing of the shear values by $\pm 10\%$ results in very small changes in the transition temperatures, showing that the normalization procedure is not overly sensitive to changes in the measured value of percent shear.

Correlation of Transition Temperature of Full-Size and Subsize Specimens

The effect of specimen size on the DBTT can be explained as suggested by Davidenkov.³⁵ The yield stress (σ_y) depends on temperature, increasing as the temperature decreases, while the cleavage fracture stress (σ_f) is assumed to be temperature independent (see Figure 22). The intersection of these curves determines the DBTT. The size effect can be explained by a statistical theory of strength, whose mathematical interpretation was given by Weibull.³⁶ It is based on the assumption that brittle failure is determined by the value of the local stress in the piece at the point where the most critical structural defect is located. Using the theory of probability, Weibull established the dependence of the brittle strength on the volume of the specimen. For the same states of stress but various dimensions of the specimens, the brittle fracture stress changes as $V^{-1/m}$, where V is the volume of the specimen and m is a constant of the material. The scatter obtained will be larger for smaller specimens. The dependence of brittle fracture on the volume of specimens for different types of tests has been experimentally confirmed.^{37,38}

The above discussion is illustrated in Figure 22. The dependence of yield stress on temperature can be expressed as:

$$\sigma_y = Ae^{c/T}, \quad (13)$$

where A and c are constants, and T is temperature in Kelvin. According to Weibull,^{36,37} the dependence of the brittle fracture stress on volume is:

$$\sigma_f = ZV^{-1/m}, \quad (14)$$

where Z and m are constants. If we define the DBTT as the temperature at which σ_y is raised so that it equals σ_f (see Figure 22), then:

$$Ae^{\frac{c}{DBTT}} = ZV^{-1/m}. \quad (15)$$

Taking the natural logarithm of Equation (15) results in:

$$DBTT = \frac{1}{R - S \ln V}, \quad (16)$$

where R and S are constants.

Thus, Equation (16) describes, in general, the shift of DBTT to lower temperatures due to a reduction in size. However, different notch geometries result in different stress distributions under the notch for different subsize

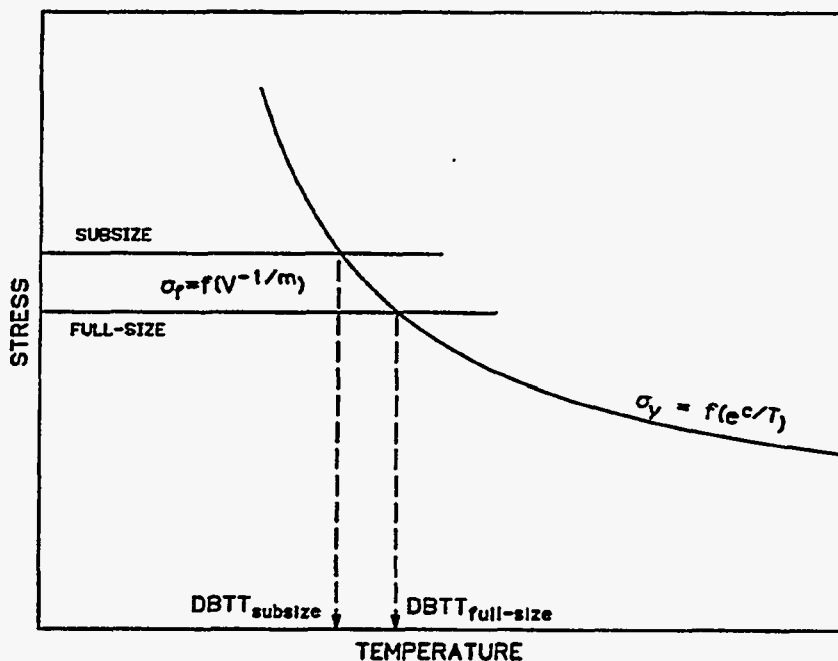

Figure 22. Stress-temperature diagram showing the effect of specimen size on transition temperature.

specimens, which does not allow the use of Equation (16) for a quantitative account of size effects in notched impact tests. Nevertheless, it suggests the establishment of an empirical correlation:

$$DBTT_{full\ size} = DBTT_{subsize} + M, \quad (17)$$

where $DBTT_{full\ size}$ and $DBTT_{subsize}$ are transition temperatures for full-size and subsize specimens, respectively, and M is a shift of DBTT due to specimen size. A similar approach has been used in refs. 6, 11, and 19.

The following procedure was used to determine the temperature correction, M . Absorbed energy values from subsize specimens were normalized by Equation (11). These data were then fit with a hyperbolic tangent function [see Equation (1)] to determine temperatures at 41 J (T_{41J}), 68 J (T_{68J}), and at the middle of the transition zone (T_{MT}). Figures 23 through 26 summarize the comparison of transition temperatures for full-size and different subsize specimens. Transition temperatures at 50% shear ($T_{50\%}$) were also included in the analysis. The data show a linear correspondence of transition temperatures. The following equations were obtained for the different subsize specimens:

$$DBTT_{full\ size} = DBTT_{type\ 1} + 30 (\pm 28) \text{ } ^\circ\text{C}, \quad (18)$$

$$DBTT_{full\ size} = DBTT_{type\ 2} + 53 (\pm 24) \text{ } ^\circ\text{C}, \quad (19)$$

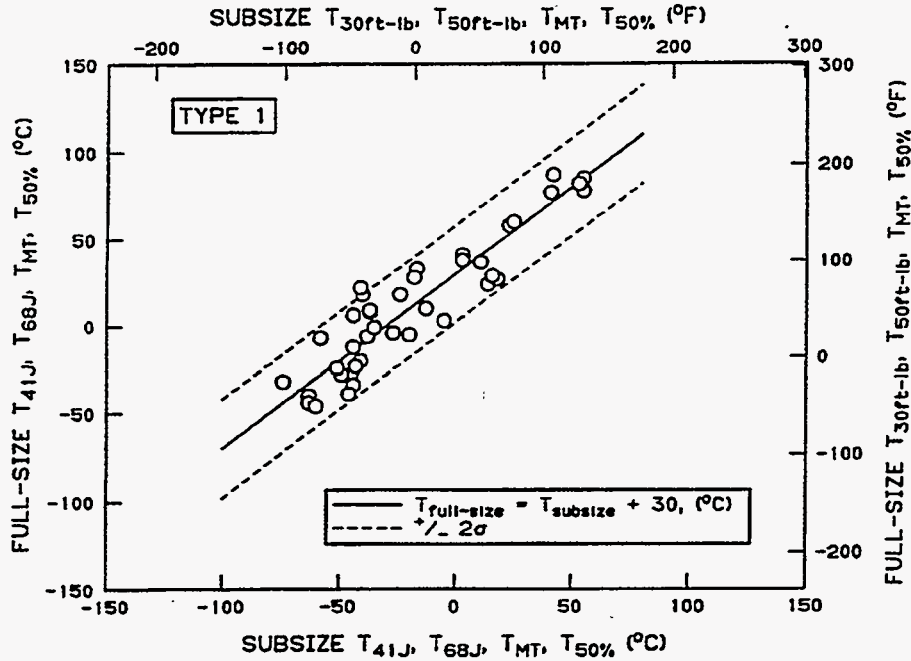

Figure 23. Correlation of transition temperatures determined with data from full-size specimens and normalized data from type 1 subsize specimens.

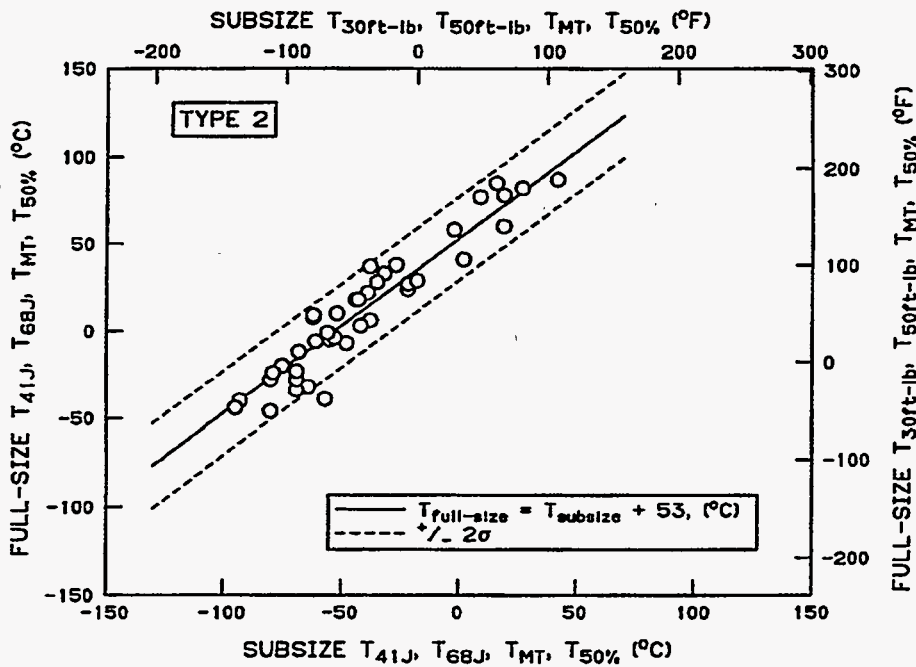

Figure 24. Correlation of transition temperatures determined with data from full-size specimens and normalized data from type 2 subsize specimens.

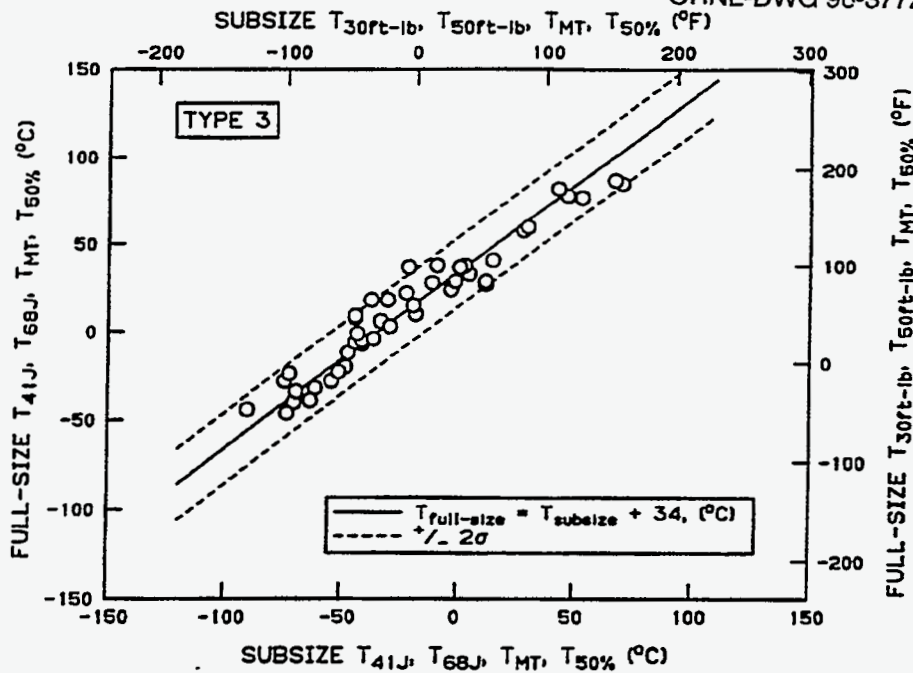

Figure 25. Correlation of transition temperatures determined with data from full-size specimens and normalized data from type 3 subsize specimens.

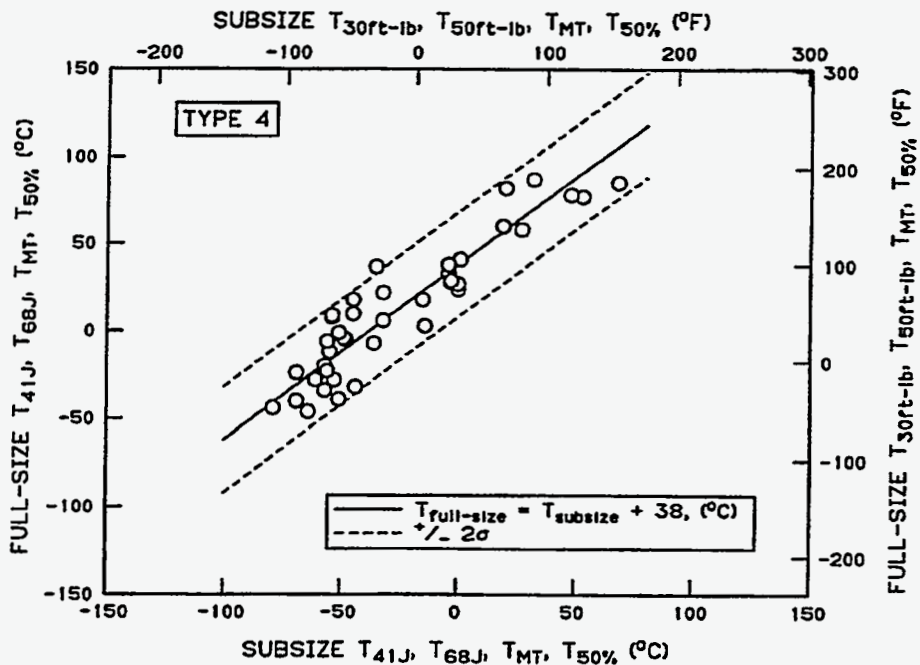

Figure 26. Correlation of transition temperatures determined with data from full-size specimens and normalized data from type 4 subsize specimens.

$$DBTT_{full\ size} = DBTT_{type\ 3} + 34 (\pm 20) \text{ } ^\circ\text{C}, \quad (20)$$

and

$$DBTT_{full\ size} = DBTT_{type\ 4} + 38 (\pm 30) \text{ } ^\circ\text{C}, \quad (21)$$

where the numbers in parentheses are $\pm 2\sigma$ intervals.

Figure 27 shows the dependence of the temperature-size correction, M, taken from Equations (18)-(21), on the nominal FV, Bb^2 , for the subsize specimens used in this work. The solid line is a fit to the data:

$$M = 98 - 15.1 \times \ln(Bb^2). \quad (22)$$

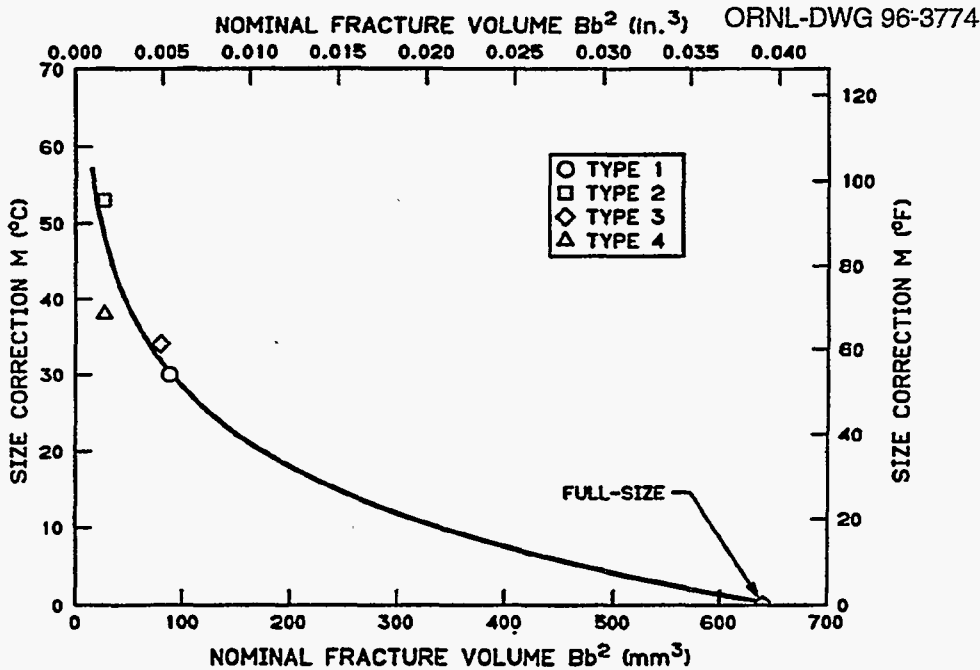

Figure 27. Temperature correction for subsize specimens as a function of nominal fracture volume.

The form of this fit is suggested by Equation (16), and the equation was forced to give a correction factor of 0 for the full-size specimen. The trend agrees, in general, with the scheme for the effects of specimen size on the DBTT based on the statistical theory of strength (see Figure 22). Deviations from this dependence reflect the constraint effects of different notch dimensions, but the form of the dependence may be used as guidance to estimate size corrections for subsize specimens.

Normalization of Data from Subsize Specimens

The normalization procedure described above was tested with the data from the ten materials used in the present work (see Appendices A through K). The absorbed energies for subsize specimens were normalized by Equation (11).

Test temperatures were then shifted forward by size adjustment values from Equations (18)-(21) for the corresponding subsize specimens. Data from subsize specimens normalized by this procedure correspond very well with the mean and 95% confidence intervals from full-size specimens, as Figures 28 through 35 show. The normalization did not produce a good match on the upper-shelf regime for materials with USEs greater than 200 J for full-size specimens, as Figures 36 and 37 show. Excessive deformation at the anvils and the failure of subsize specimens of tough materials to fracture completely when tested on the upper shelf are factors that led to the poor agreement. If the data are restricted to materials with full-size USE levels less than 200 J, the present method for normalizing data from subsize specimens can give good correlations with data for full-size Charpy specimens.

Examination of the standard deviations reported for Equations (18)-(21) shows that the type 3 specimen has the smallest value, suggesting that this specimen is the best of the four types examined for determining the DBTT, since it results in the smallest error. It was also noted that this specimen was more likely to fracture completely when tested in the upper-shelf regime, whereas the other subsize specimens tended to wrap around the tup rather than fracture in this regime. This failure to fracture on the upper shelf is exacerbated for materials with high USE levels and accounts for the poor agreement found for materials with upper-shelf levels of over 200 J, as measured with full-size specimens. The types 1 and 2 subsize specimens have relatively short notch depth to specimen width ratios (a/W) of 0.16 and 0.15, respectively. The type 3 specimen has a relatively deeper notch, with $a/W = 0.2$. This relatively deeper notch will encourage fracture on the upper shelf. The type 4 specimen has a value of $a/W = 0.25$, but the specimen thickness is only 3 mm as compared to 5 mm for type 3. The greater thickness of the type 3 specimen will increase the transverse constraint developed in this specimen as compared to the thinner type 4 specimen, and again encourage fracture. Thus, of all the specimens tested, the type 3 specimen seems to be the best, although it is the largest of the subsize specimens. If a smaller specimen is desired, it might be useful to consider a geometry with a relatively deeper notch (a/W greater than 0.25) to encourage fracture on the upper shelf and improve the correlation with full-size specimens.

Summary and Conclusions

Five types of subsize specimens from ten materials were studied in the present work. The principal results are as follows:

1. Subsize Charpy specimens may be useful for studies when material availability is limited. The broken halves of surveillance specimens can be remachined into subsize specimens to extend current surveillance programs and to monitor annealing response. The small specimen recommended by ASTM E 23 is too long for such an application.
2. It was found that (1) an increase in the notch depth decreases the USE but has little effect on the DBTT, (2) a decrease of the notch root radius reduces the USE and increases the DBTT, (3) variation of notch angle from 30 to 45° while keeping the remaining dimensions identical does not result in any effect on transition temperature or USE, and (4) span and impact velocity (in the ranges studied) do not affect the USE and DBTT.
3. The following equation is proposed for normalizing impact energy values from subsize Charpy specimens (E):

$$E = E_{\text{subsize}} \times \left[NF_{\text{brittle}} \frac{100 - \text{SHEAR}}{100} + NF_{\text{ductile}} \frac{\text{SHEAR}}{100} \right],$$

where NF_{brittle} is a normalization factor equal to the ratio of the area of the fracture surface of the full-size specimen to the area of the fracture surface of the corresponding subsize specimen; NF_{ductile} is an empirical normalization factor equal to 5.1, 18.3, 6.3, and 21.3 for types 1, 2, 3, and 4 subsize specimens, respectively; and SHEAR is the percent of shear fracture on the fracture surface.

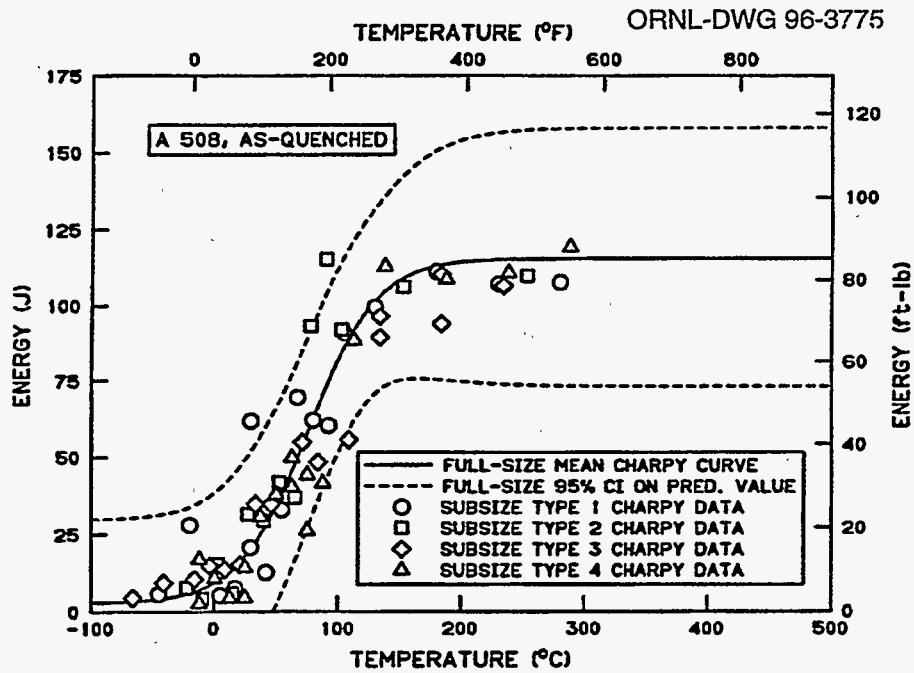

Figure 28. Comparison of Charpy curve for full-size specimens of A 508, as-quenched, with data from subsize specimens normalized by the proposed procedure.

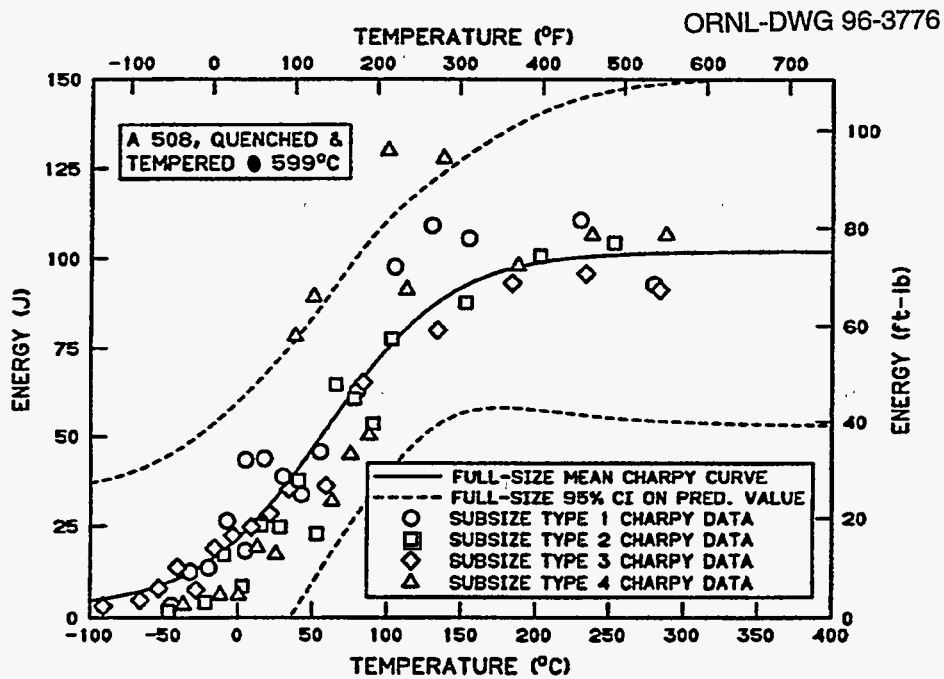

Figure 29. Comparison of Charpy curve for full-size specimens of A 508, quenched and tempered at 599°C, with data from subsize specimens normalized by the proposed procedure.

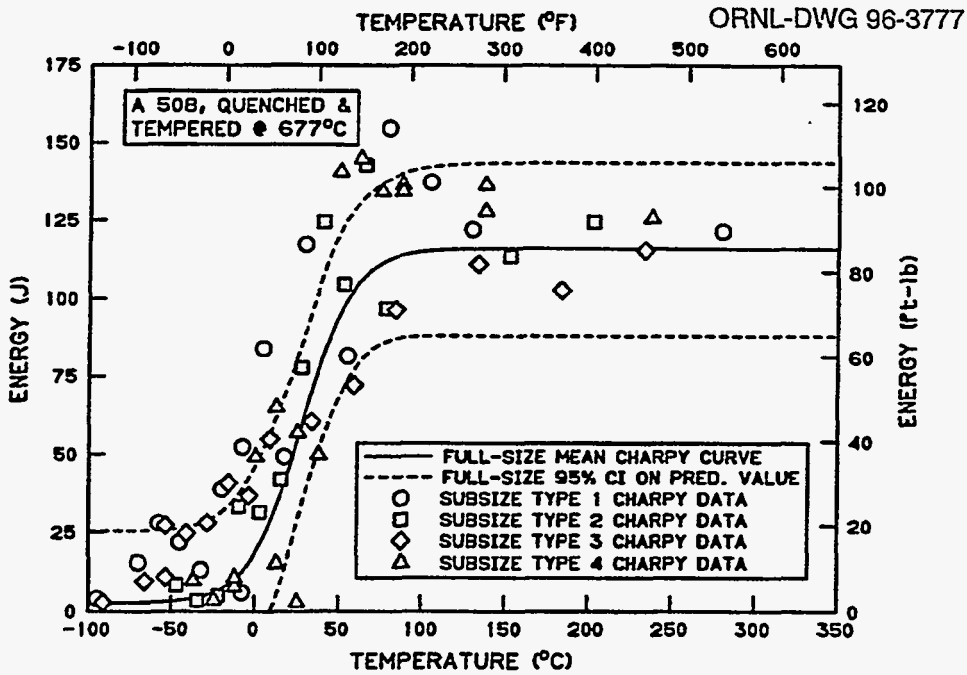

Figure 30. Comparison of Charpy curve for full-size specimens of A 508, quenched and tempered at 677°C, with data from subsize specimens normalized by the proposed procedure.

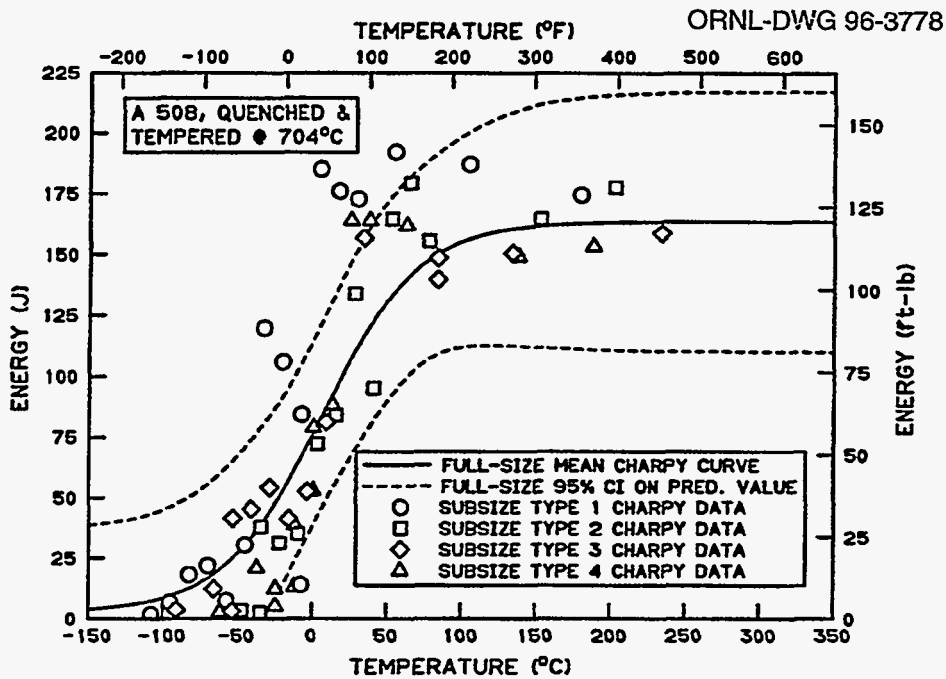

Figure 31. Comparison of Charpy curve for full-size specimens of A 508, quenched and tempered at 704°C, with data from subsize specimens normalized by the proposed procedure.

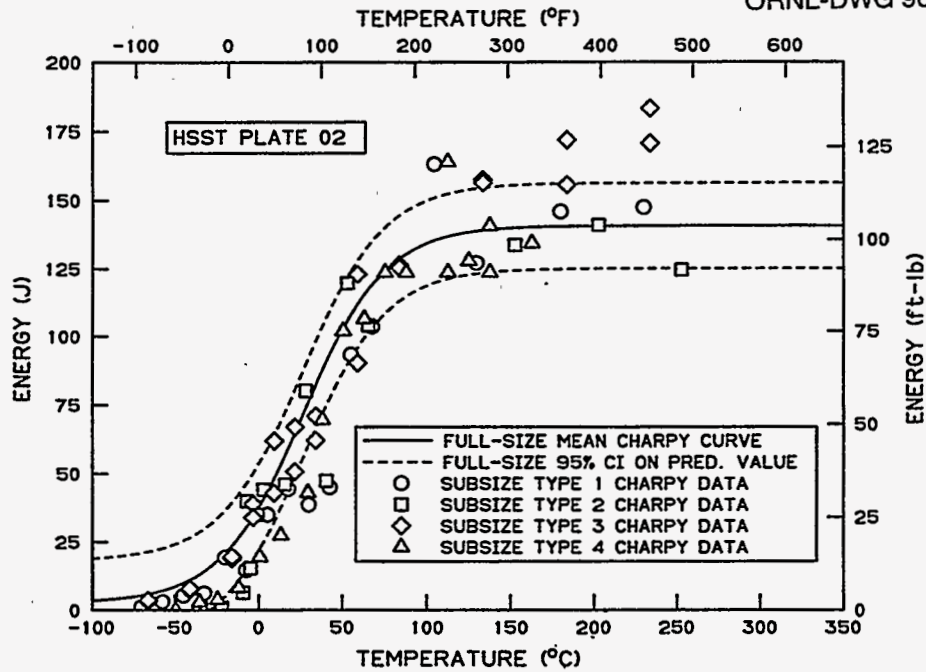

Figure 32. Comparison of Charpy curve for full-size specimens of HSST Plate 02, T-L orientation, quarter thickness, with data from subsize specimens normalized by the proposed procedure.

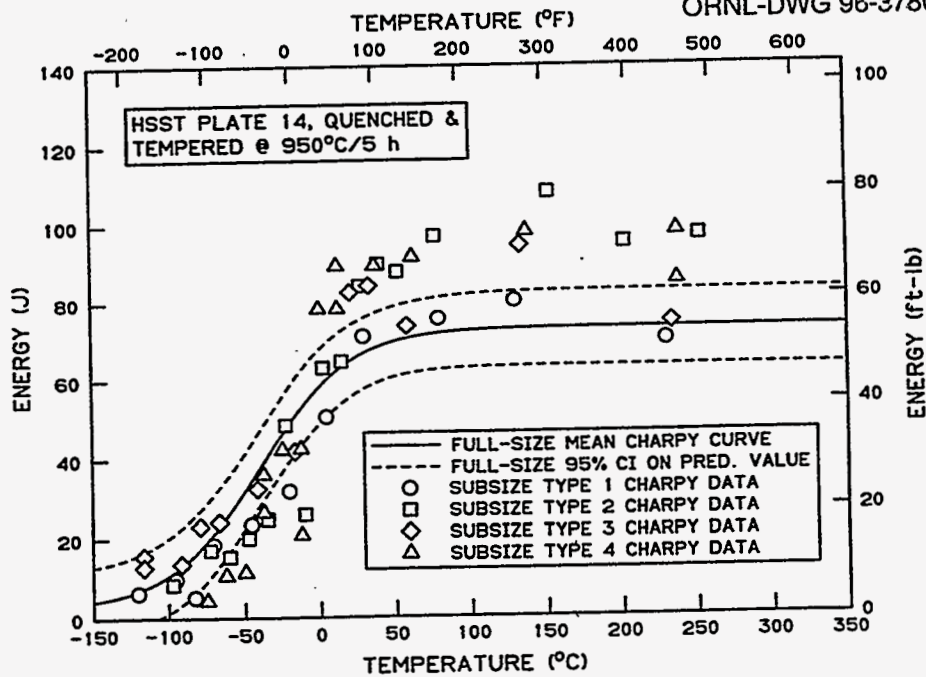

Figure 33. Comparison of Charpy curve for full-size specimens of HSST Plate 14, quenched and tempered at 950°C, with data from subsize specimens normalized by the proposed procedure.

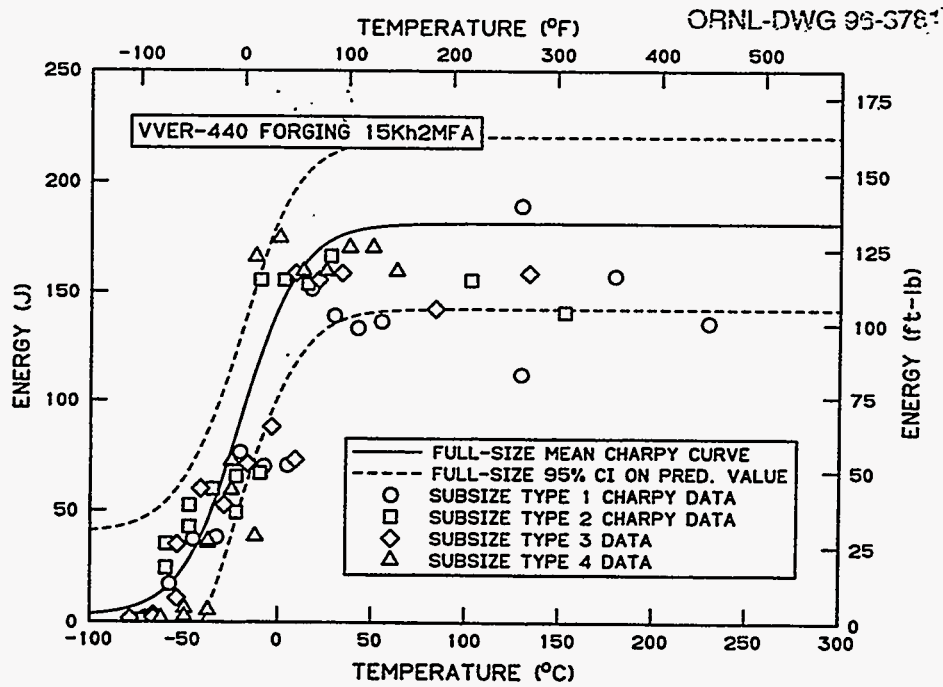

Figure 34. Comparison of Charpy curve for full-size specimens of 15Kh2MFA with data from subsize specimens normalized by the proposed procedure.

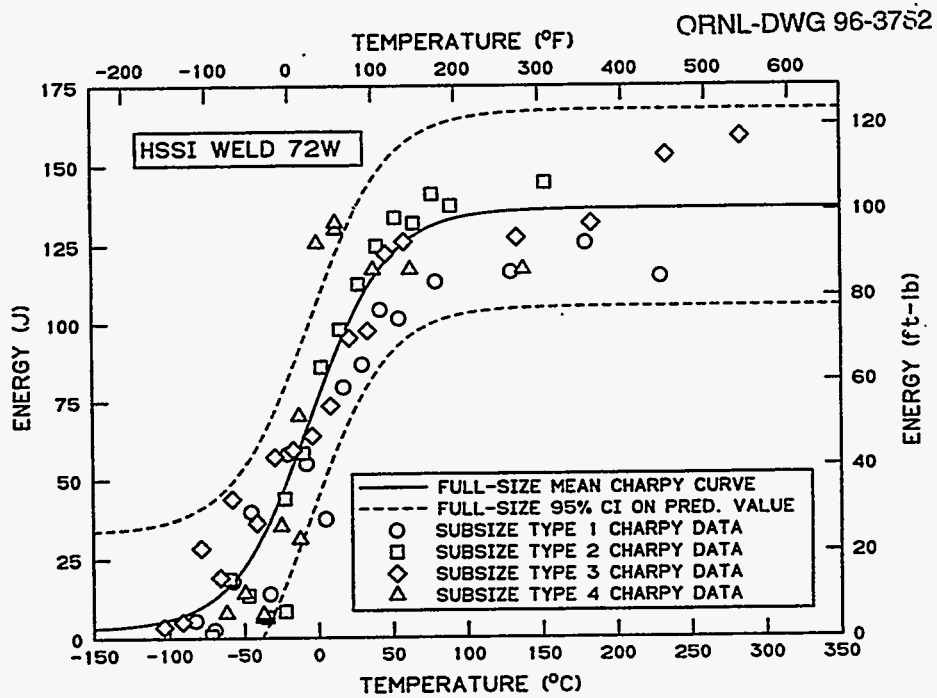

Figure 35. Comparison of Charpy curve for full-size specimens of HSSI weld 72W with data from subsize Charpy specimens normalized by the proposed procedure.

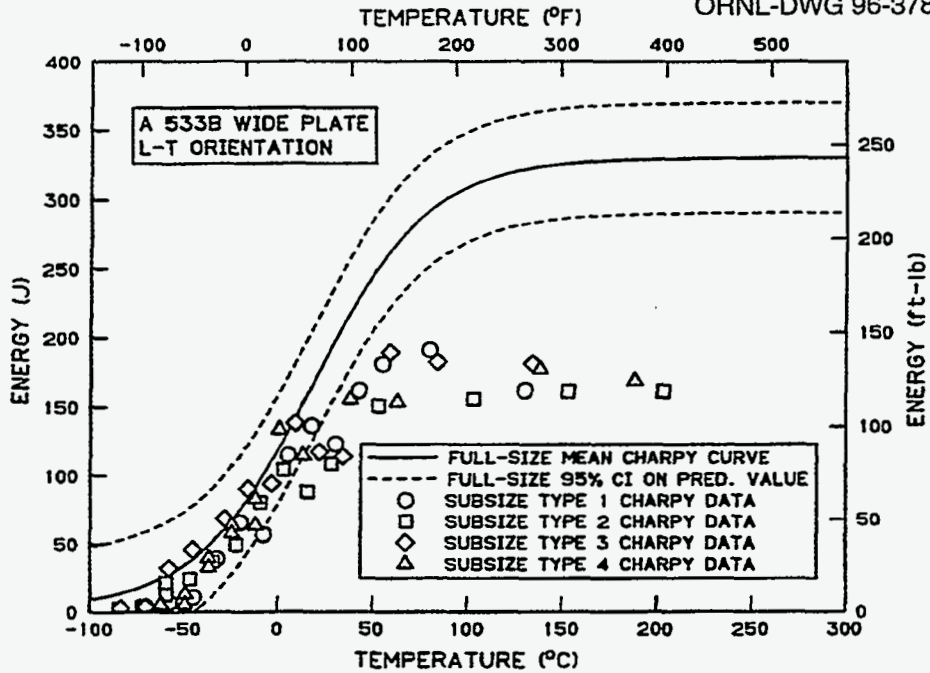

Figure 36. Comparison of Charpy curve for full-size specimens of A 533 wide plate, L-T orientation, with data from subsize Charpy specimens normalized by the proposed procedure.

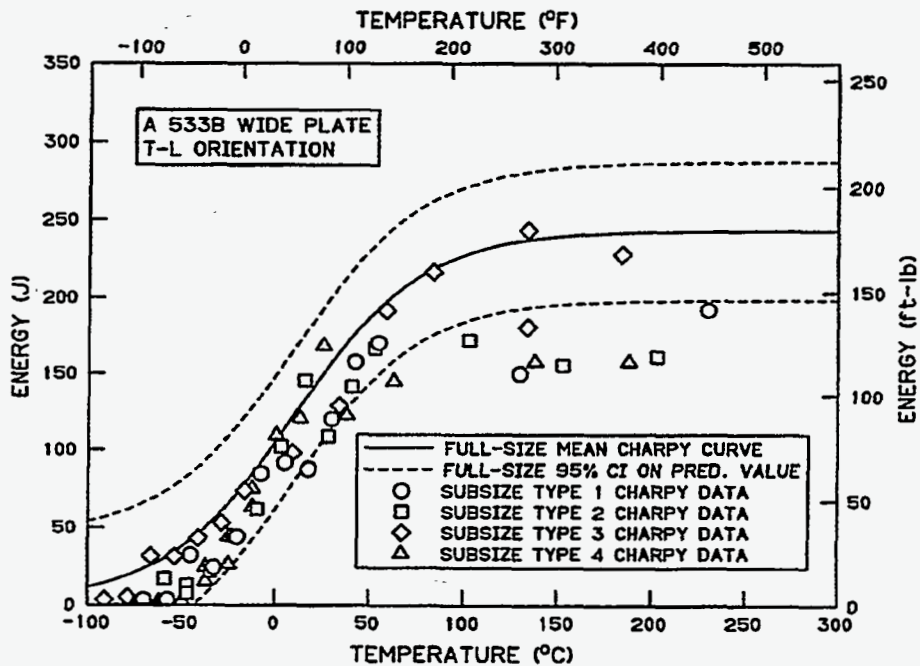

Figure 37. Comparison of Charpy curve for full-size specimens of A 533 wide plate, T-L orientation, with data from subsize Charpy specimens normalized by the proposed procedure.

4. The empirical correlations between the DBTT of full-size and the different subsize specimens were determined as follows:

$$DBTT_{\text{full size}} = DBTT_{\text{type 1}} + 30 (\pm 28) \text{ } ^\circ\text{C} ,$$

$$DBTT_{\text{full size}} = DBTT_{\text{type 2}} + 53 (\pm 24) \text{ } ^\circ\text{C} ,$$

$$DBTT_{\text{full size}} = DBTT_{\text{type 3}} + 34 (\pm 20) \text{ } ^\circ\text{C} ,$$

and

$$DBTT_{\text{full size}} = DBTT_{\text{type 4}} + 38 (\pm 30) \text{ } ^\circ\text{C} ,$$

where the numbers in parentheses are $\pm 2\sigma$ intervals. Further understanding of the shift in the DBTT as a function of specimen size needs to be pursued.

5. Results obtained from the subsize specimens as well as the empirical correlations can be used for development of an ASTM standard practice for impact testing of subsize specimens for supplementary surveillance data in nuclear applications.

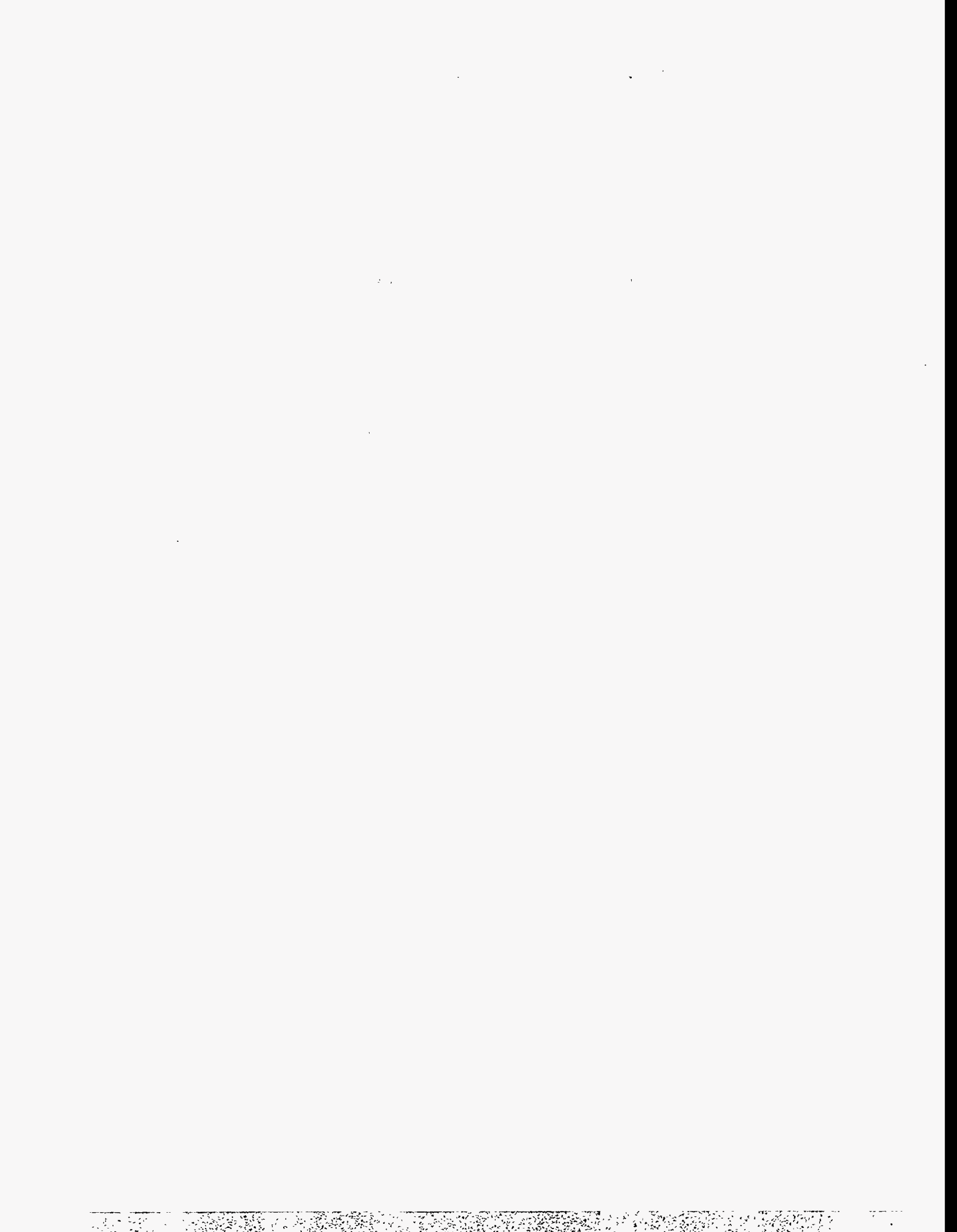

References

1. A. D. Amayev, A. M. Kryukov, and M. A. Sokolov, "Recovery of the Transition Temperature of Irradiated WWER-440 Vessel Metal by Annealing," pp. 369-79 in *Radiation Embrittlement of Nuclear Reactor Pressure Vessel Steels: An International Review (Fourth Volume)*, ASTM STP 1170, ed. L. E. Steele, American Society for Testing and Materials, Philadelphia, 1993.*
2. A. M. Kryukov and M. A. Sokolov, "Investigation of Material Behavior Under Reirradiation After Annealing Using Subsize Specimens," pp. 417-23 in *Small Specimen Test Techniques Applied to Nuclear Reactor Vessel Thermal Annealing and Plant Life Extension*, ASTM STP 1204, ed. W. R. Corwin, F. M. Haggag, and W. L. Server, American Society for Testing and Materials, Philadelphia, 1993.*
3. W. L. Server, "Review of In-Service Thermal Annealing of Nuclear Reactor Pressure Vessels," pp. 979-1008 in *Effects of Radiation on Materials: Twelfth International Symposium*, ASTM STP 870, ed. F. A. Garner and J. S. Perrin, American Society for Testing and Materials, Philadelphia, 1985.*
4. T. R. Mager, *Feasibility and Methodology for Thermal Annealing of an Embrittled Reactor Vessel*, Vol. 2, EPRI NP-2712, Electric Power Research Institute, Palo, Alto, Calif., November 1982.
5. R. Ahlstrand, E. N. Klausnitzer, D. Lange, C. Leitz, D. Pastor, and M. Valo, "Evaluation of the Recovery Annealing of the Reactor Pressure Vessel of NPP Nord (Greifswald) Units 1 and 2 by Means of Subsize Impact Specimens," pp. 312-43 in *Radiation Embrittlement of Nuclear Reactor Pressure Vessel Steels: An International Review (Fourth Volume)*, ASTM STP 1170, ed. L. E. Steele, American Society for Testing and Materials, Philadelphia, 1993.*
6. A. D. Amayev, V. I. Badanin, A. M. Kryukov, V. A. Nikolayev, M. F. Rogov, and M. A. Sokolov, "Use of Subsize Specimens for Determination of Radiation Embrittlement of Operating Reactor Pressure Vessels," pp. 424-39 in *Small Specimen Test Techniques Applied to Nuclear Reactor Vessel Thermal Annealing and Plant Life Extension*, ASTM STP 1204, ed. W. R. Corwin, F. M. Haggag, and W. L. Server, American Society for Testing and Materials, Philadelphia, 1993.*
7. *Standard Test Method for Notched Bar Impact Testing of Metallic Materials*, ASTM E 23-93a, American Society for Testing and Materials, Philadelphia, 1993.*
8. M. Grounes, "Review of Swedish Work on Irradiation Effects in Pressure Vessel Steels and on Significance of Data Obtained," pp. 224-59 in *Effects of Radiation on Structural Metals*, ASTM STP 426, American Society for Testing and Materials, Philadelphia, 1967.*
9. C. Curll, "Subsize Charpy Correlation with Standard Charpy," *Mater. Res. Stand.*, 91-94 (February 1961).*
10. R. C. McNicol, "Correlation of Charpy Test Results for Standard and Nonstandard Size Specimens," *Weld. Res. Suppl.*, 385-93 (September 1965).*
11. E. Klausnitzer, H. Kristof, and R. Leistner, "Assessment of Toughness Behavior of Low-Alloy Steels by Subsize Impact Specimens," pp. 3-37 in *Transactions of the 8th International Conference on Structural Mechanics in Reactor Technology, Brussels, August 1985*, Vol. G, International Association for Structural Mechanics in Reactor Technology, 1986.*

12. W. R. Corwin and A. M. Hougland, "Effect of Specimen Size and Material Condition on the Charpy Impact Properties of 9Cr-1Mo-V-Nb Steel," pp. 325-38 in *The Use of Small-Scale Specimens for Testing Irradiated Material, ASTM STP 888*, ed. W. R. Corwin and G. E. Lucas, American Society for Testing and Materials, Philadelphia, 1986.*
13. G. E. Lucas, G. R. Odette, J. W. Sheckherd, P. McConnell, and J. Perrin, "Subsized Bend and Charpy V-Notch Specimens for Irradiated Testing," pp. 304-24 in *The Use of Small-Scale Specimens for Testing Irradiated Material, ASTM STP 888*, ed. W. R. Corwin and G. E. Lucas, American Society for Testing and Materials, Philadelphia, 1986.*
14. H. Kayano, H. Kurishita, A. Kimura, M. Narui, M. Yamazaki, and Y. Suzuki, "Charpy Impact Testing Using Miniature Specimens and Its Application to the Study of Irradiation Behavior of Low-Activation Ferritic Steels," *J. Nucl. Mater.* **179-181**, 425-88 (1991).*
15. H. Kurishita, H. Kayano, M. Narui, M. Yamazaki, Y. Kano, and I. Shibahara, "Effects of V-Notch Dimensions on Charpy Impact Test Results for Differently Sized Miniature Specimens of Ferritic Steel," *Mater. Trans. JIM* **34**(11), 1042-52 (1993).*
16. M. P. Manahan and C. Charles, "A Generalized Methodology for Obtaining Quantitative Charpy Data from Test Specimens of Nonstandard Dimensions," *Nucl. Technol.* **90**, 245-59 (May 1990).*
17. M. P. Manahan, "Determination of Charpy Transition Temperature of Ferritic Steels Using Miniaturized Specimens," *J. Mater. Sci.* **25**, 3429-38 (1990).*
18. R. K. Nanstad, D. E. McCabe, R. L. Swain, and M. K. Miller, Martin Marietta Energy Systems, Inc., Oak Ridge Natl. Lab., Oak Ridge, Tenn., *Chemical Composition and RT_{NDT} Determinations for Midland Weld WF-70*, USNRC Report NUREG/CR-5914 (ORNL-740), December 1992.†
19. D. J. Alexander and R. L. Klueh, "Specimen Size Effects in Charpy Impact Testing," pp. 179-91 in *Charpy Impact Test: Factors and Variables, ASTM STP 1072*, ed. J. M. Holt, American Society for Testing and Materials, Philadelphia, 1990.*
20. A. S. Kumar, F. A. Garner, and M. L. Hamilton, "Effect of Specimen Size on the Upper-Shelf Energy of Ferritic Steels," pp. 487-95 in *Effects of Radiation on Materials: 14th International Symposium (Volume II)*, ASTM STP 1046, ed. N. H. Packan, R. E. Stoller, and A. S. Kumar, American Society for Testing and Materials, Philadelphia, 1990.*
21. B. S. Loudon, A. S. Kumar, F. A. Garner, M. L. Hamilton, and W. L. Hu, "The Influence of Specimen Size on Charpy Impact Testing of Unirradiated HT-9," *J. Nucl. Mater.* **155-157**, 662-67 (1988).*
22. A. S. Kumar, B. S. Loudon, F. A. Garner, and M. L. Hamilton, "Recent Improvements in Size Effects Correlations for DBTT and Upper-Shelf Energy of Ferritic Steels," pp. 47-61 in *Small Specimen Test Techniques Applied to Nuclear Reactor Vessel Thermal Annealing and Plant Life Extension, ASTM STP 1204*, ed. W. R. Corwin, F. M. Haggag, and W. L. Server, American Society for Testing and Materials, Philadelphia, 1993.*
23. W. R. Corwin, R. L. Klueh, and J. M. Vitek, "Effect of Specimen Size and Nickel Content on the Impact Properties of 12 Cr-1 MoVW Ferritic Steel," *J. Nucl. Mater.* **122-123**, 343-48 (1984).*
24. F. Abe, T. Noda, H. Araki, M. Okada, M. Narui, and H. Kayano, "Effect of Specimen Size on the Ductile-Brittle Transition Behavior and the Fracture Sequence of 9Cr-W Steels," *J. Nucl. Mater.* **150**, 292-301 (1987).*

25. E. N. Klausnitzer and G. Hofmann, "Reconstituted Impact Specimens with Small Inserts," pp. 76-90 in *Effects of Radiation on Materials: 15th International Symposium, ASTM STP 1125*, ed. R. E. Stoller, A. S. Kumar, and D. S. Gelles, American Society for Testing and Materials, Philadelphia, 1992.*
26. N. H. Fahey, "Effects of Variables in Charpy Impact Testing," *Mater. Res. Stand.* **1**, 872-76 (November 1961).*
27. G. E. Lucas, G. R. Odette, J. W. Sheckherd, and M. R. Krishnadev, "Recent Progress in Subsize Charpy Impact Specimen Testing for Fusion Reactor Materials Development," *Fusion Technol.* **10**, 728-33 (1986).*
28. H. Neuber, *Theory of Notch Stresses*, Springer, Berlin, 1958.*
29. A. S. Kumar, S. T. Rosinski, N. S. Cannon, and M. L. Hamilton, "Subsize Specimen Testing of a Nuclear Reactor Pressure Vessel Material," pp. 147-55 in *Effects of Radiation on Materials: 16th International Symposium, ASTM STP 1175*, ed. A. S. Kumar, D. S. Gelles, R. K. Nanstad, and E. A. Little, American Society for Testing and Materials, Philadelphia, 1993.*
30. A. P. Green and B. B. Hundy, "Initial Plastic Yielding in Notch Bend Tests," *J. Mech. Phys. Solids* **4**, 128-44 (1956).*
31. J. F. Knott, *Fundamentals of Fracture Mechanics*, Butterworths, London, 1973.*
32. R. Sandstrom and Y. Bergstrom, "Relationship Between Charpy V Transition Temperature in Mild Steel and Various Material Parameters," *Mater. Sci.* **18**, 177-86 (1984).*
33. T. Naniwa, M. Shibaie, M. Tanaki, H. Tani, H. N. Shiota, and T. Shiraishi, "Effects of the Striking Edge Radius on the Charpy Impact Test," pp. 67-80 in *Charpy Impact Test: Factors and Variables, ASTM STP 1072*, ed. J. M. Holt, American Society for Testing and Materials, Philadelphia, 1990.*
34. R. K. Nanstad and M. A. Sokolov, "Charpy Impact Test Results on Five Materials and NIST Verification Specimens Using Instrumented 2-mm and 8-mm Strikers," pp. 111-39 in *Pendulum Impact Machines: Procedures and Specimens for Verification, ASTM STP 1248*, ed. T. A. Siewert and A. K. Schmieder, American Society for Testing and Materials, Philadelphia, 1995.*
35. N. N. Davidenkov, *The Problems of Impact in Material Science*, Academy of Science of U.S.S.R., 1938 (in Russian).*
36. W. Weibull, "A Statistical Theory of the Strength of Materials," p. 151 in *Proceedings of the Royal Swedish Institute for Engineering Research*, 1939.*
37. W. Weibull, "A Survey of 'Statistical Effects' in the Field of Material Failure," *Appl. Mech. Rev.* **5**(11), 449-51 (1952).*
38. N. Davidenkov, E. Shevandin, and F. Wittmann, "The Influence of Size on the Brittle Strength of Steel," *J. Appl. Mech.*, 63-67 (March 1947).*

*Available in public technical libraries.

†Available for purchase from National Technical Information Service, Springfield, VA 22161.

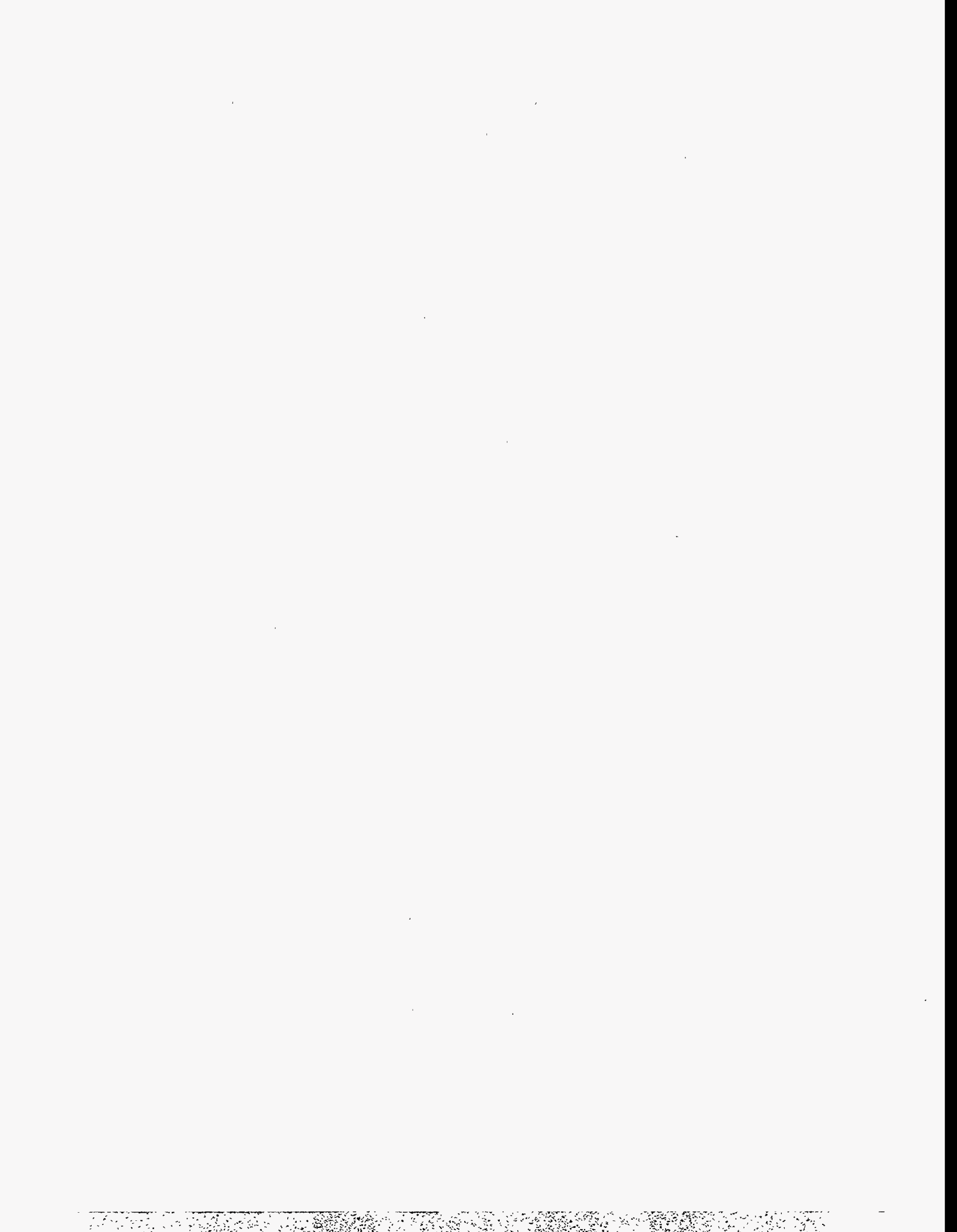

APPENDIX A

A 533 GRADE B WIDE PLATE, LT ORIENTATION

SET NAME: CE_23_LT
NOTE: LAYER 3

IDENT	TEMPERATURE		ENERGY		EXPANSION		SHEAR (PERCENT)
	(DEG C)	(DEG F)	(J)	(FT-LB)	(MM)	(IN)	
CE2301	-75.0	-103.0	8.00	5.90	0.00	0.000	0.0
CE2307	-50.0	-58.0	19.01	14.02	0.30	0.012	10.0
CE2310	-25.0	-13.0	67.03	49.44	0.94	0.037	28.0
CE2312	-25.0	-13.0	82.04	60.51	1.17	0.046	25.0
CE2308	-25.0	-13.0	64.03	47.23	0.97	0.038	21.0
CE2302	0.0	32.0	114.05	84.12	1.60	0.063	20.0
CE2316	0.0	32.0	146.07	107.73	1.80	0.071	46.0
CE2306	0.0	32.0	127.06	93.71	1.65	0.065	38.0
CE2305	23.0	73.4	170.08	125.44	2.01	0.079	65.0
CE2311	23.0	73.4	176.08	129.87	1.96	0.077	50.0
CE2314	23.0	73.4	180.08	132.82	2.24	0.088	77.0
CE2315	50.0	122.0	248.11	183.00	2.31	0.091	100.0
CE2303	100.0	212.0	315.14	232.44	2.01	0.079	100.0
CE2318	150.0	302.0	318.15	234.65	2.01	0.079	100.0
CE2317	150.0	302.0	323.15	238.34	1.70	0.067	100.0
CE2320	200.0	392.0	339.15	250.15	1.68	0.066	100.0
CE2321	200.0	392.0	340.16	250.89	1.50	0.059	100.0
CE2309	250.0	482.0	320.15	236.13	1.52	0.060	100.0
CE2319	300.0	572.0	323.15	238.34	1.65	0.065	100.0

NUMBER OF SPECIMENS: 19

SET NAME: CE_24_LT
NOTE: LAYER 4

IDENT	TEMPERATURE		ENERGY		EXPANSION		SHEAR (PERCENT)
	(DEG C)	(DEG F)	(J)	(FT-LB)	(MM)	(IN)	
CE2411	-75.0	-103.0	10.00	7.38	0.13	0.005	0.0
CE2401	-50.0	-58.0	36.02	26.56	0.48	0.019	18.0
CE2413	-50.0	-58.0	45.02	33.21	0.71	0.028	13.0
CE2414	-25.0	-13.0	105.05	77.48	1.42	0.056	30.0
CE2404	-25.0	-13.0	91.04	67.15	1.30	0.051	27.0
CE2407	-25.0	-13.0	72.03	53.13	1.04	0.041	21.0
CE2405	0.0	32.0	122.06	90.02	1.75	0.069	45.0
CE2406	0.0	32.0	111.05	81.91	1.50	0.059	52.0
CE2415	0.0	32.0	145.07	107.00	1.93	0.076	50.0
CE2416	23.0	73.4	163.07	120.28	2.03	0.080	40.0
CE2403	23.0	73.4	166.08	122.49	2.11	0.083	52.0
CE2412	23.0	73.4	162.07	119.54	2.18	0.086	75.0
CE2409	50.0	122.0	219.10	161.60	2.29	0.090	100.0
CE2402	150.0	302.0	285.13	210.30	1.98	0.078	100.0
CE2420	150.0	302.0	305.14	225.06	1.55	0.061	100.0
CE2421	200.0	392.0	342.16	252.36	1.63	0.064	100.0
CE2418	200.0	392.0	326.15	240.55	1.60	0.063	100.0
CE2417	250.0	482.0	337.15	248.67	1.68	0.066	100.0
CE2419	300.0	572.0	341.16	251.62	1.65	0.065	100.0

NUMBER OF SPECIMENS: 19

SOURCE: ANALYSIS SET

ANALYSIS SET NAMES: CE_21_LT, CE_22_LT, CE_23_LT AND CE_24_LT

SET NAME: CE_21_LT

NOTE: LAYER 1

IDENT	TEMPERATURE		ENERGY (J)	(FT-LB)	EXPANSION		SHEAR (PERCENT)
	(DEG C)	(DEG F)			(MM)	(IN)	
CE2116	-75.0	-103.0	6.00	4.43	0.08	0.003	0.0
CE2104	-50.0	-58.0	15.01	11.07	0.23	0.009	13.0
CE2108	-25.0	-13.0	47.02	34.68	0.76	0.030	18.0
CE2112	-25.0	-13.0	79.04	58.29	1.17	0.046	24.0
CE2107	-25.0	-13.0	60.03	44.27	0.97	0.038	18.0
CE2110	0.0	32.0	121.06	89.29	1.60	0.063	47.0
CE2105	0.0	32.0	161.07	118.80	2.06	0.081	52.0
CE2115	0.0	32.0	153.07	112.90	1.88	0.074	48.0
CE2101	23.0	73.4	179.08	132.08	2.31	0.091	70.0
CE2102	23.0	73.4	166.08	122.49	2.01	0.079	60.0
CE2109	23.0	73.4	177.08	130.61	2.11	0.083	62.0
CE2113	50.0	122.0	284.13	209.56	2.11	0.083	100.0
CE2106	50.0	122.0	263.12	194.07	2.13	0.084	100.0
CE2114	75.0	167.0	353.16	260.48	2.13	0.084	100.0
CE2111	100.0	212.0	341.16	251.62	1.83	0.072	100.0
CE2120	150.0	302.0	343.16	253.10	2.06	0.081	100.0
CE2103	150.0	302.0	347.16	256.05	1.93	0.076	100.0
CE2118	200.0	392.0	340.16	250.89	1.80	0.071	100.0
CE2121	200.0	392.0	331.15	244.24	1.57	0.062	100.0
CE2119	250.0	482.0	339.15	250.15	1.70	0.067	100.0
CE2117	300.0	572.0	335.15	247.20	1.70	0.067	100.0

NUMBER OF SPECIMENS: 21

SET NAME: CE_22_LT

NOTE: LAYER 2

IDENT	TEMPERATURE		ENERGY (J)	(FT-LB)	EXPANSION		SHEAR (PERCENT)
	(DEG C)	(DEG F)			(MM)	(IN)	
CE2214	-75.0	-103.0	9.00	6.64	0.10	0.004	0.0
CE2208	-50.0	-58.0	17.01	12.54	0.25	0.010	11.0
CE2215	-25.0	-13.0	48.02	35.42	0.74	0.029	23.0
CE2216	-25.0	-13.0	50.02	36.89	0.76	0.030	20.0
CE2203	-25.0	-13.0	59.03	43.54	0.86	0.034	23.0
CE2211	0.0	32.0	123.06	90.76	1.63	0.064	25.0
CE2212	0.0	32.0	110.05	81.17	1.50	0.059	30.0
CE2204	0.0	32.0	110.05	81.17	1.42	0.056	18.0
CE2201	23.0	73.4	145.07	107.00	1.75	0.069	50.0
CE2202	23.0	73.4	179.08	132.08	2.08	0.082	70.0
CE2209	23.0	73.4	153.07	112.90	1.80	0.071	55.0
CE2206	50.0	122.0	229.10	168.98	2.29	0.090	100.0
CE2207	100.0	212.0	262.12	193.33	2.06	0.081	100.0
CE2218	150.0	302.0	303.14	223.58	1.80	0.071	100.0
CE2213	150.0	302.0	310.14	228.75	1.65	0.065	100.0
CE2219	200.0	392.0	321.15	236.87	1.52	0.060	100.0
CE2220	200.0	392.0	322.15	237.60	1.52	0.060	100.0
CE2221	250.0	482.0	346.16	255.31	1.63	0.064	100.0
CE2217	300.0	572.0	304.14	224.32	1.42	0.056	100.0

NUMBER OF SPECIMENS: 19

SOURCE: CE_21_LT, CE_22_LT, CE_23_LT AND CE_24_LT ANALYSIS SETS

Y VARIABLE: ENERGY

MODEL PARAMETERS

LOWER SHELF ENERGY [HELD FIXED]: 2.7 (J), 2.0 (FT-LB)

MID-TRANSITION TEMPERATURE: 18.0 (DEG C), 64.4 (DEG F)

TRANSITION ZONE WIDTH: 121.8 (C DEG), 219.2 (F DEG)

UPPER SHELF ENERGY: 329.7 (J), 243.2 (FT-LB)

UPPER SHELF ENERGY: 329.7 (J), 243.2 (FT-LB)

TEMPERATURE [41 (J), 30.2 (FT-LB) ENERGY]: -43.5 (DEG C), -46.3 (DEG F)

TEMPERATURE [68 (J), 50.2 (FT-LB) ENERGY]: -24.3 (DEG C), -11.7 (DEG F)

NOTE: NONE

MODEL SET NAME: 4

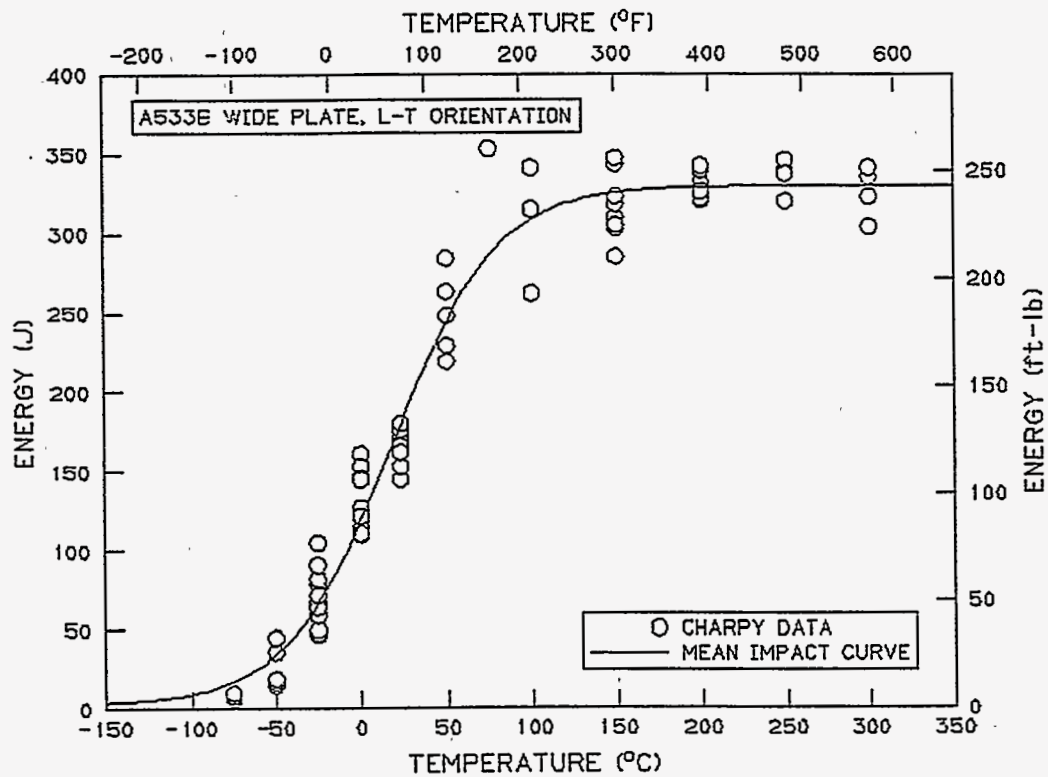

SOURCE: CE_21_LT, CE_22_LT, CE_23_LT AND CE_24_LT ANALYSIS SETS

Y VARIABLE: EXPANSION

MODEL PARAMETERS

LOWER SHELF EXPANSION [HELD FIXED]: 0.061 (MM), 0.0024 (IN)

MID-TRANSITION TEMPERATURE: -26.8 (DEG C), -16.3 (DEG F)

TRANSITION ZONE WIDTH: 46.7 (C DEG), 84.1 (F DEG)

UPPER SHELF EXPANSION: 1.872 (MM), 0.0737 (IN)

UPPER SHELF EXPANSION: 1.872 (MM), 0.0737 (IN)

NOTE: NONE

MODEL SET NAME: 3

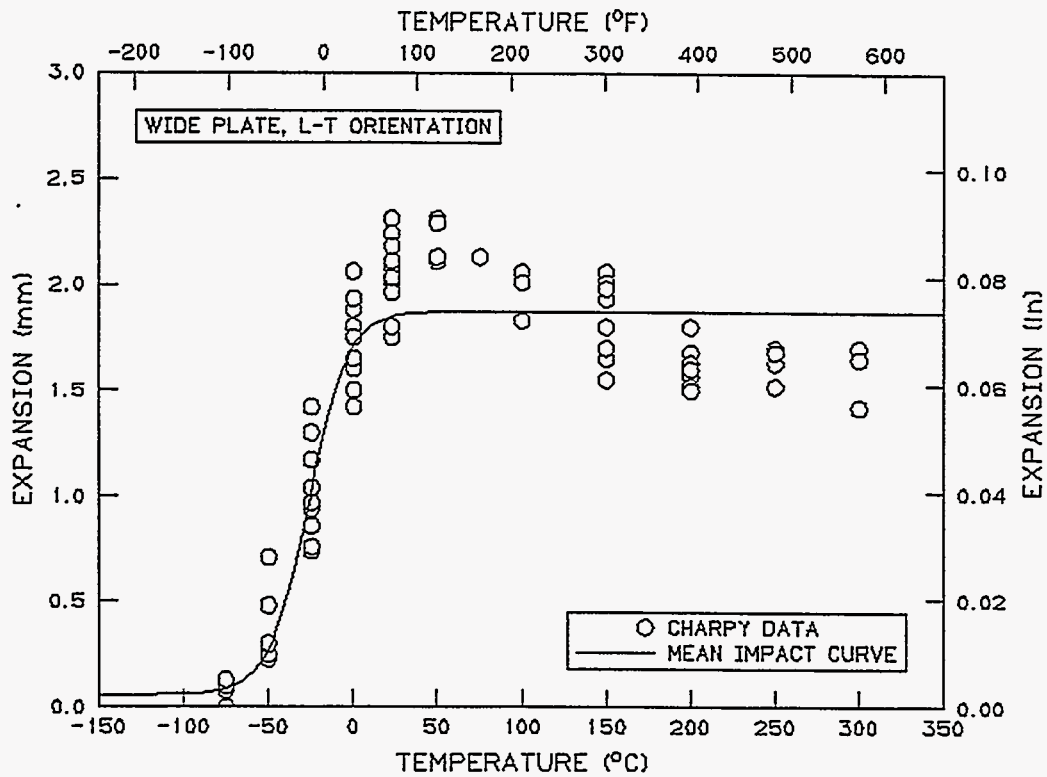

SOURCE: CE_21_LT, CE_22_LT, CE_23_LT AND CE_24_LT ANALYSIS SETS

Y VARIABLE: SHEAR

MODEL PARAMETERS

LOWER SHELF SHEAR [HELD FIXED]: 0 (PERCENT)

MID-TRANSITION TEMPERATURE: 8.4 (DEG C), 47.1 (DEG F)

TRANSITION ZONE WIDTH: 95.2 (C DEG), 171.4 (F DEG)

UPPER SHELF SHEAR: 100 (PERCENT)

UPPER SHELF SHEAR: 100 (PERCENT)

NOTE: NONE

MODEL SET NAME: 5

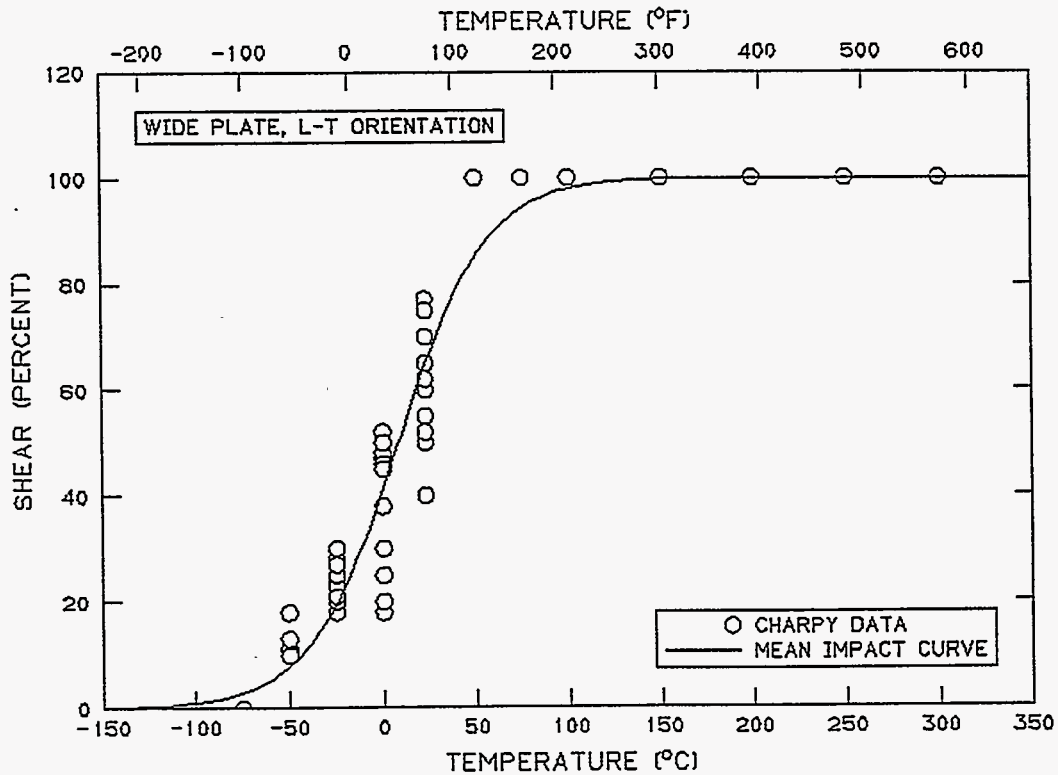

SOURCE: ANALYSIS SET
ANALYSIS SET NAME: WP_LT.T1

SET NAME: WP_LT.T1
NOTE: WIDE PLATE L-T ORIENTATION - TYPE 1

IDENT	TEMPERATURE		ENERGY		EXPANSION		SHEAR (PERCENT)
	(DEG C)	(DEG F)	(J)	(FT-LB)	(MM)	(IN)	
CL3	-100.0	-148.0	0.95	0.70	0.00	0.000	0.0
CL4	-87.5	-125.5	1.76	1.30	0.00	0.000	5.0
CL2	-75.0	-103.0	2.85	2.10	0.08	0.003	5.0
CL5	-62.5	-80.5	9.36	6.90	0.38	0.015	30.0
CL6	-50.0	-58.0	15.32	11.30	0.66	0.026	40.0
CL7	-37.5	-35.5	13.15	9.70	0.51	0.020	40.0
CL8	-25.0	-13.0	24.81	18.30	0.89	0.035	65.0
CL9	-12.5	9.5	28.20	20.80	0.91	0.036	80.0
CL10	0.0	32.0	25.08	18.50	0.91	0.036	85.0
CL14	12.5	54.5	31.73	23.40	0.97	0.038	100.0
CL11	25.0	77.0	35.39	26.10	1.02	0.040	100.0
CL12	50.0	122.0	37.42	27.60	0.99	0.039	100.0
CL13	100.0	212.0	31.73	23.40	1.02	0.040	100.0

NUMBER OF SPECIMENS: 13

SOURCE: WP_LT.T1 ANALYSIS SET

Y VARIABLE: ENERGY

MODEL PARAMETERS

LOWER SHELF ENERGY [HELD FIXED]: 0.1 (J), 0.1 (FT-LB)

MID-TRANSITION TEMPERATURE: -37.2 (DEG C), -34.9 (DEG F)

TRANSITION ZONE WIDTH: 81.8 (C DEG), 147.3 (F DEG)

UPPER SHELF ENERGY: 34.7 (J), 25.6 (FT-LB)

UPPER SHELF ENERGY: 34.7 (J), 25.6 (FT-LB)

NOTE: NONE

MODEL SET NAME: 4

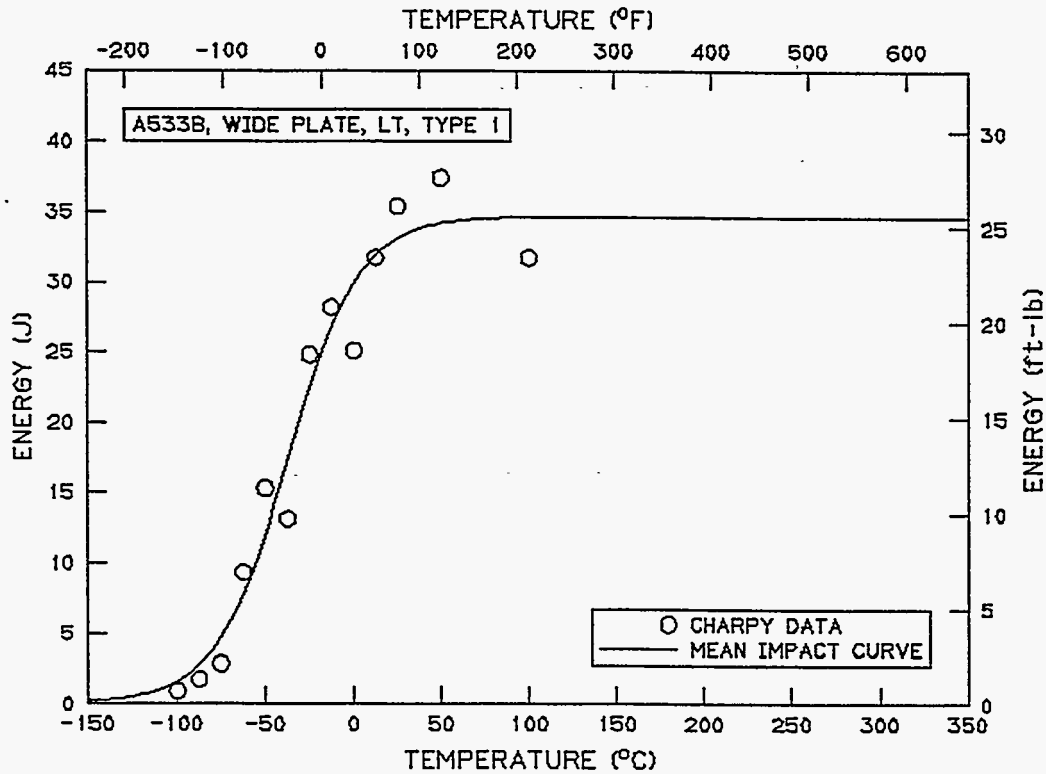

SOURCE: WP_LT.T1 ANALYSIS SET

Y VARIABLE: EXPANSION

MODEL PARAMETERS

LOWER SHELF EXPANSION [HELD FIXED]: 0.000 (MM), 0.0000 (IN)

MID-TRANSITION TEMPERATURE: -50.8 (DEG C), -59.4 (DEG F)

TRANSITION ZONE WIDTH: 60.1 (C DEG), 108.1 (F DEG)

UPPER SHELF EXPANSION: 0.988 (MM), 0.0389 (IN)

UPPER SHELF EXPANSION: 0.988 (MM), 0.0389 (IN)

NOTE: NONE

MODEL SET NAME: 6

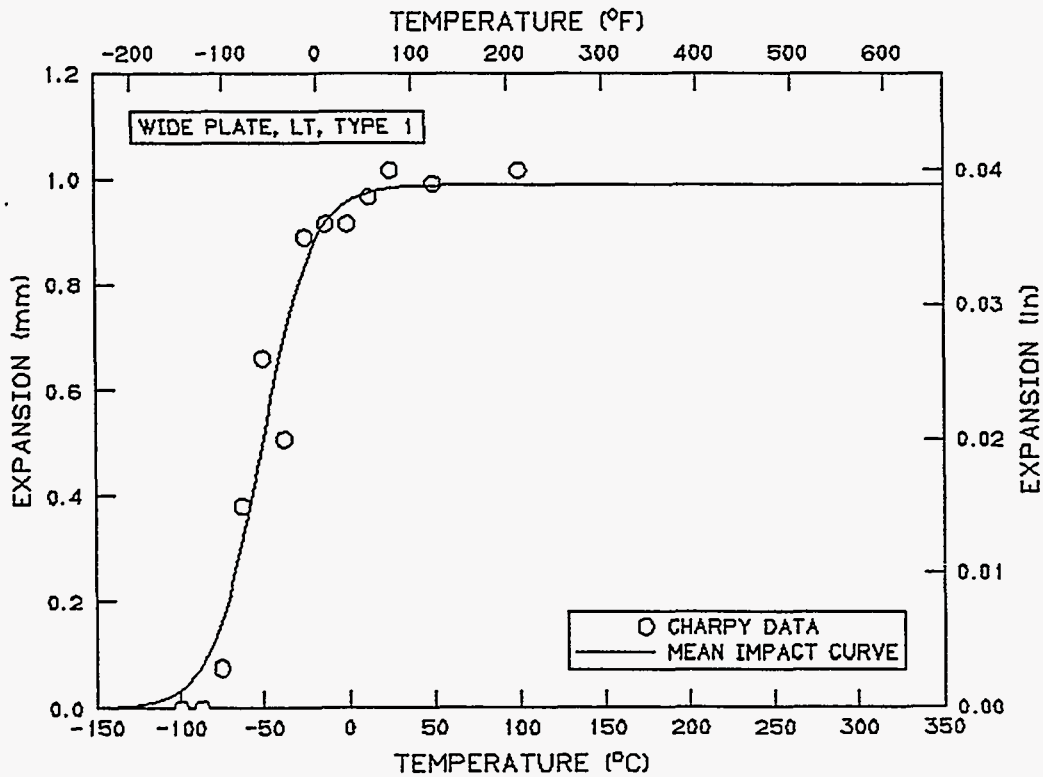

SOURCE: WP_LT.T1 ANALYSIS SET

Y VARIABLE: SHEAR

MODEL PARAMETERS

LOWER SHELF SHEAR [HELD FIXED]: 0 (PERCENT)

MID-TRANSITION TEMPERATURE:-37.1 (DEG C),-34.9 (DEG F)

TRANSITION ZONE WIDTH: 74.9 (C DEG),134.9 (F DEG)

UPPER SHELF SHEAR [HELD FIXED]: 100 (PERCENT)

UPPER SHELF SHEAR: 100 (PERCENT)

TEMPERATURE [50 (PERCENT),50 (PERCENT) SHEAR]:-37.1 (DEG C),-34.9 (DEG F)

NOTE: NONE

MODEL SET NAME: 7

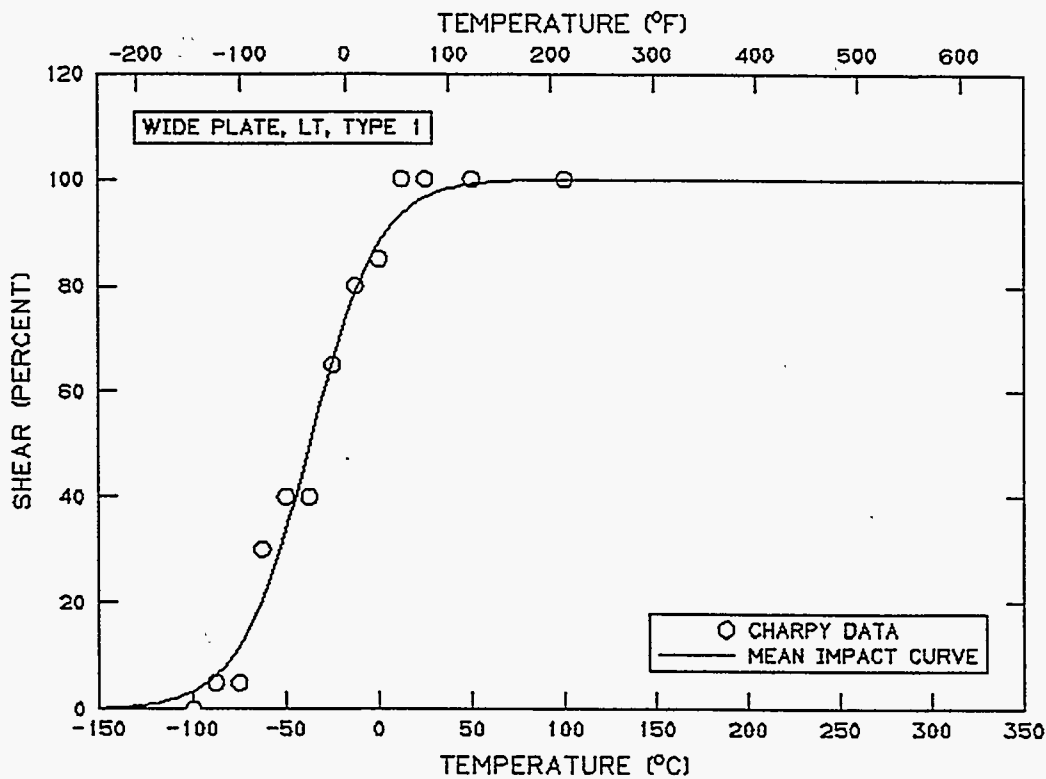

SOURCE: ANALYSIS SET
ANALYSIS SET NAME: WP_LT.T2

SET NAME: WP_LT.T2

NOTE: WIDE PLATE TYPE 2 SPECIMENS IN THE L-T ORIENTATION

IDENT	TEMPERATURE		ENERGY (J)	EXPANSION			SHEAR (PERCENT)
	(DEG C)	(DEG F)		(FT-LB)	(MM)	(IN)	
CL34	-137.5	-215.5	0.27	0.20	0.00	0.000	0.0
CL32	-125.0	-193.0	0.54	0.40	0.00	0.000	0.0
CL46	-125.0	-193.0	0.41	0.30	0.00	0.000	0.0
CL33	-112.5	-170.5	2.44	1.80	0.10	0.004	5.0
CL45	-112.5	-170.5	1.49	1.10	0.03	0.001	0.0
CL31	-100.0	-148.0	2.71	2.00	0.13	0.005	5.0
CL35	-87.5	-125.5	3.93	2.90	0.28	0.011	10.0
CL36	-75.0	-103.0	4.75	3.50	0.36	0.014	20.0
CL37	-62.5	-80.5	5.97	4.40	0.41	0.016	50.0
CL38	-50.0	-58.0	7.46	5.50	0.61	0.024	UNKNOWN
CL39	-37.5	-35.5	6.64	4.90	0.53	0.021	UNKNOWN
CL40	-25.0	-13.0	7.32	5.40	0.61	0.024	UNKNOWN
CL41	0.0	32.0	8.68	6.40	0.64	0.025	UNKNOWN
CL43	50.0	122.0	8.54	6.30	0.74	0.029	100.0
CL42	100.0	212.0	8.81	6.50	0.71	0.028	100.0
CL44	150.0	302.0	8.81	6.50	0.76	0.030	100.0

NUMBER OF SPECIMENS: 16

SOURCE: WP_LT.T2 ANALYSIS SET

Y VARIABLE: ENERGY

MODEL PARAMETERS

LOWER SHELF ENERGY [HELD FIXED]: 0.1 (J), 0.1 (FT-LB)

MID-TRANSITION TEMPERATURE: -80.0 (DEG C), -112.1 (DEG F)

TRANSITION ZONE WIDTH: 88.0 (C DEG), 158.5 (F DEG)

UPPER SHELF ENERGY: 8.6 (J), 6.3 (FT-LB)

UPPER SHELF ENERGY: 8.6 (J), 6.3 (FT-LB)

NOTE: NONE

MODEL SET NAME: 0

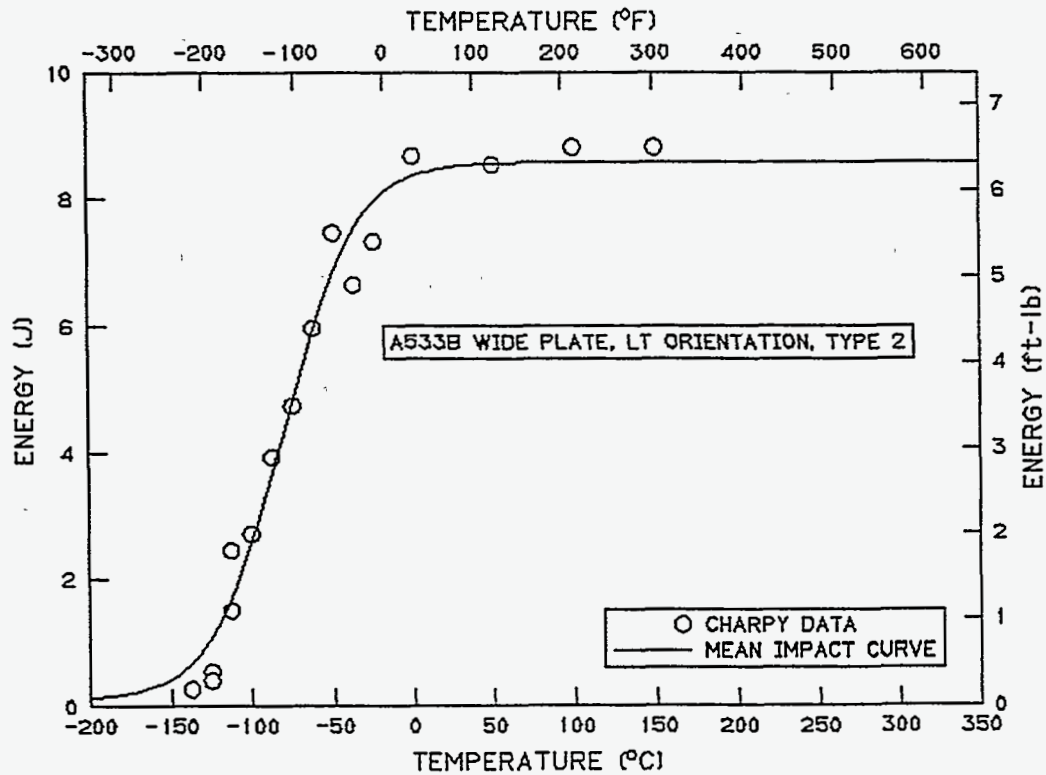

SOURCE: WP_LT.T2 ANALYSIS SET

Y VARIABLE: EXPANSION

MODEL PARAMETERS

LOWER SHELF EXPANSION [HELD FIXED]: 0.000 (MM), 0.0000 (IN)

MID-TRANSITION TEMPERATURE: -72.6 (DEG C), -98.6 (DEG F)

TRANSITION ZONE WIDTH: 77.6 (C DEG), 139.7 (F DEG)

UPPER SHELF EXPANSION: 0.704 (MM), 0.0277 (IN)

UPPER SHELF EXPANSION: 0.704 (MM), 0.0277 (IN)

NOTE: NONE

MODEL SET NAME: 9

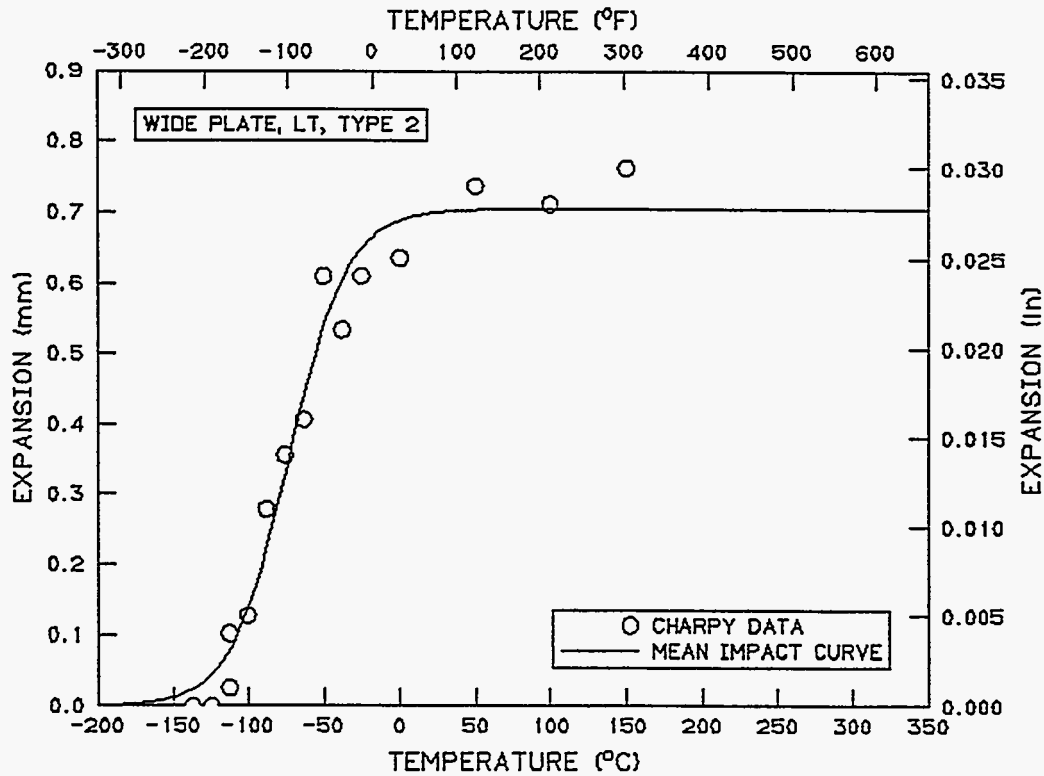

SOURCE: WP_LT.T2 ANALYSIS SET

Y VARIABLE: SHEAR

MODEL PARAMETERS

LOWER SHELF SHEAR [HELD FIXED]: 0 (PERCENT)

MID-TRANSITION TEMPERATURE: -62.0 (DEG C), -79.5 (DEG F)

TRANSITION ZONE WIDTH: 43.0 (C DEG), 77.4 (F DEG)

UPPER SHELF SHEAR [HELD FIXED]: 100 (PERCENT)

UPPER SHELF SHEAR: 100 (PERCENT)

NOTE: NONE

MODEL SET NAME: 8

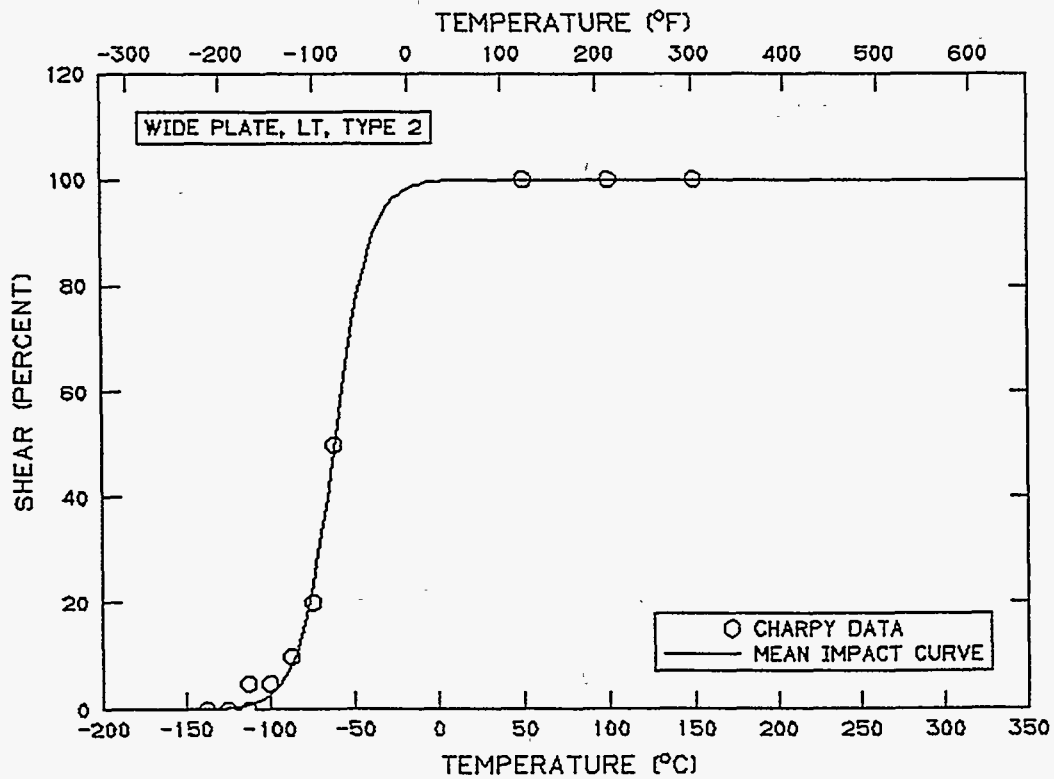

SOURCE: ANALYSIS SET
ANALYSIS SET NAME: WP_LT.T3

SET NAME: WP_LT.T3

NOTE: WIDE PLATE TYPE 3 SPECIMENS, L-T ORIENTATION

IDENT	TEMPERATURE		ENERGY		EXPANSION		SHEAR (PERCENT)
	(DEG C)	(DEG F)	(J)	(FT-LB)	(MM)	(IN)	
CL17	-117.5	-179.5	0.68	0.50	0.00	0.000	0.0
CL16	-104.0	-155.2	0.95	0.70	0.00	0.000	0.0
CL18	-92.0	-133.6	7.59	5.60	0.30	0.012	10.0
CL19	-79.4	-111.0	10.30	7.60	0.51	0.020	20.0
CL20	-62.5	-80.5	14.64	10.80	0.74	0.029	30.0
CL21	-50.0	-58.0	18.03	13.30	0.74	0.029	45.0
CL22	-37.5	-35.5	17.90	13.20	0.86	0.034	55.0
CL23	-25.0	-13.0	23.73	17.50	0.89	0.035	80.0
CL24	-12.5	9.5	20.47	15.10	0.84	0.033	75.0
CL25	0.0	32.0	19.93	14.70	0.81	0.032	75.0
CL29	25.0	77.0	29.96	22.10	0.89	0.035	100.0
CL28	50.0	122.0	28.88	21.30	0.97	0.038	100.0
CL26	100.0	212.0	28.74	21.20	1.04	0.041	100.0

NUMBER OF SPECIMENS: 13

SOURCE: WP_LT.T3 ANALYSIS SET

Y VARIABLE: ENERGY

MODEL PARAMETERS

LOWER SHELF ENERGY [HELD FIXED]: 0.1 (J), 0.1 (FT-LB)

MID-TRANSITION TEMPERATURE: -57.4 (DEG C), -71.3 (DEG F)

TRANSITION ZONE WIDTH: 113.3 (C DEG), 204.0 (F DEG)

UPPER SHELF ENERGY: 28.4 (J), 20.9 (FT-LB)

UPPER SHELF ENERGY: 28.4 (J), 20.9 (FT-LB)

NOTE: NONE

MODEL SET NAME: 1

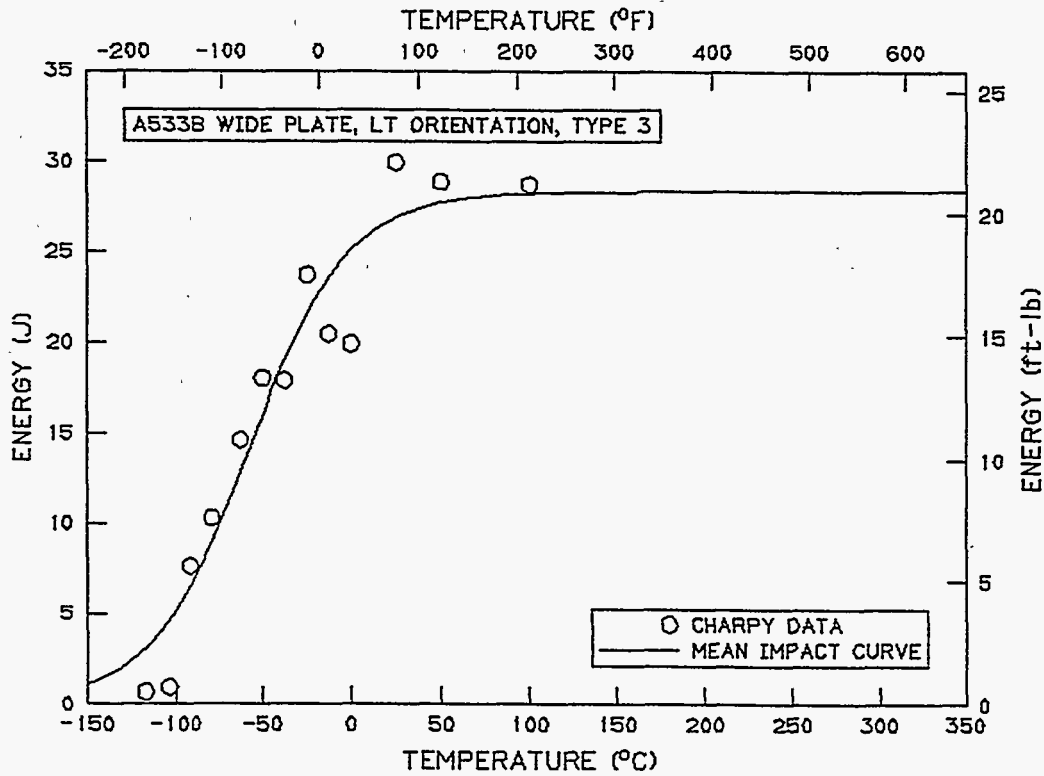

SOURCE: WP_LT.T3 ANALYSIS SET

Y VARIABLE: EXPANSION

MODEL PARAMETERS

LOWER SHELF EXPANSION [HELD FIXED]: 0.000 (MM), 0.0000 (IN)

MID-TRANSITION TEMPERATURE: -80.8 (DEG C), -113.4 (DEG F)

TRANSITION ZONE WIDTH: 47.3 (C DEG), 85.1 (F DEG)

UPPER SHELF EXPANSION: 0.895 (MM), 0.0352 (IN)

UPPER SHELF EXPANSION: 0.895 (MM), 0.0352 (IN)

NOTE: NONE

MODEL SET NAME: 2

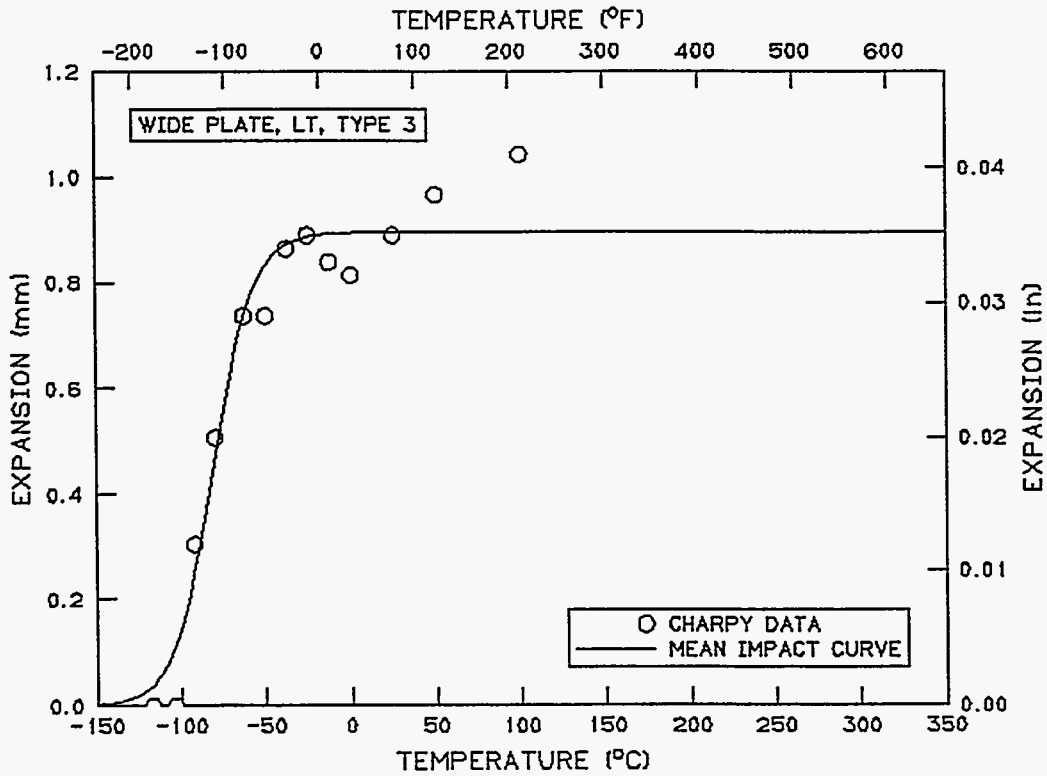

SOURCE: WP_LT.T3 ANALYSIS SET

Y VARIABLE: SHEAR

MODEL PARAMETERS

LOWER SHELF SHEAR [HELD FIXED]: 0 (PERCENT)

MID-TRANSITION TEMPERATURE:-43.7 (DEG C),-46.7 (DEG F)

TRANSITION ZONE WIDTH: 91.6 (C DEG),165.0 (F DEG)

UPPER SHELF SHEAR [HELD FIXED]: 100 (PERCENT)

UPPER SHELF SHEAR: 100 (PERCENT)

NOTE: NONE

MODEL SET NAME: 3

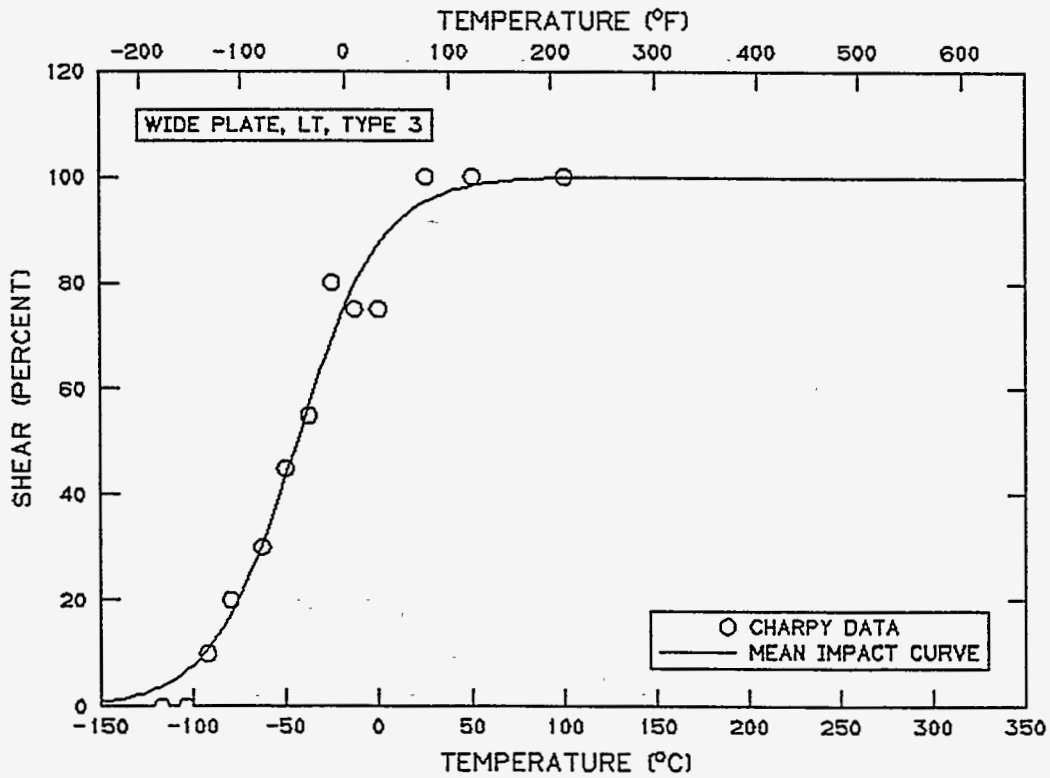

SOURCE: ANALYSIS SET
ANALYSIS SET NAME: WP_LT.T4

SET NAME: WP_LT.T4
NOTE: WIDE PLATE, L-T ORIENT., TYPE 4

IDENT	TEMPERATURE (DEG C) (DEG F)		ENERGY (J)	(FT-LB)	EXPANSION (MM) (IN)		SHEAR (PERCENT)
CL55	-100.0	-148.0	0.60	0.44	0.00	0.000	0.0
CL54	-87.5	-125.5	1.52	1.12	0.05	0.002	0.0
CL56	-87.5	-125.5	0.60	0.44	0.00	0.000	5.0
CL53	-75.0	-103.0	3.34	2.46	0.30	0.012	25.0
CL57	-75.0	-103.0	2.94	2.17	0.25	0.010	20.0
CL52	-62.5	-80.5	4.43	3.27	0.41	0.016	45.0
CL58	-62.5	-80.5	3.99	2.94	0.33	0.013	45.0
CL51	-50.0	-58.0	4.43	3.27	0.41	0.016	45.0
CL59	-50.0	-58.0	5.14	3.79	0.41	0.016	60.0
CL50	-37.5	-35.5	7.10	5.24	0.66	0.026	80.0
CL49	-25.0	-13.0	6.35	4.68	0.64	0.025	75.0
CL48	0.0	32.0	7.35	5.42	0.69	0.027	100.0
CL47	25.0	77.0	7.17	5.29	0.76	0.030	100.0
CL60	100.0	212.0	8.31	6.13	0.76	0.030	100.0
CL61	150.0	302.0	7.93	5.85	0.74	0.029	100.0

NUMBER OF SPECIMENS: 15

SOURCE: WP_LT.T4 ANALYSIS SET

Y VARIABLE: ENERGY

MODEL PARAMETERS

LOWER SHELF ENERGY [HELD FIXED]: 0.1 (J), 0.1 (FT-LB)

MID-TRANSITION TEMPERATURE: -63.2 (DEG C), -81.7 (DEG F)

TRANSITION ZONE WIDTH: 68.4 (C DEG), 123.1 (F DEG)

UPPER SHELF ENERGY: 7.7 (J), 5.7 (FT-LB)

UPPER SHELF ENERGY: 7.7 (J), 5.7 (FT-LB)

NOTE: NONE

MODEL SET NAME: 6

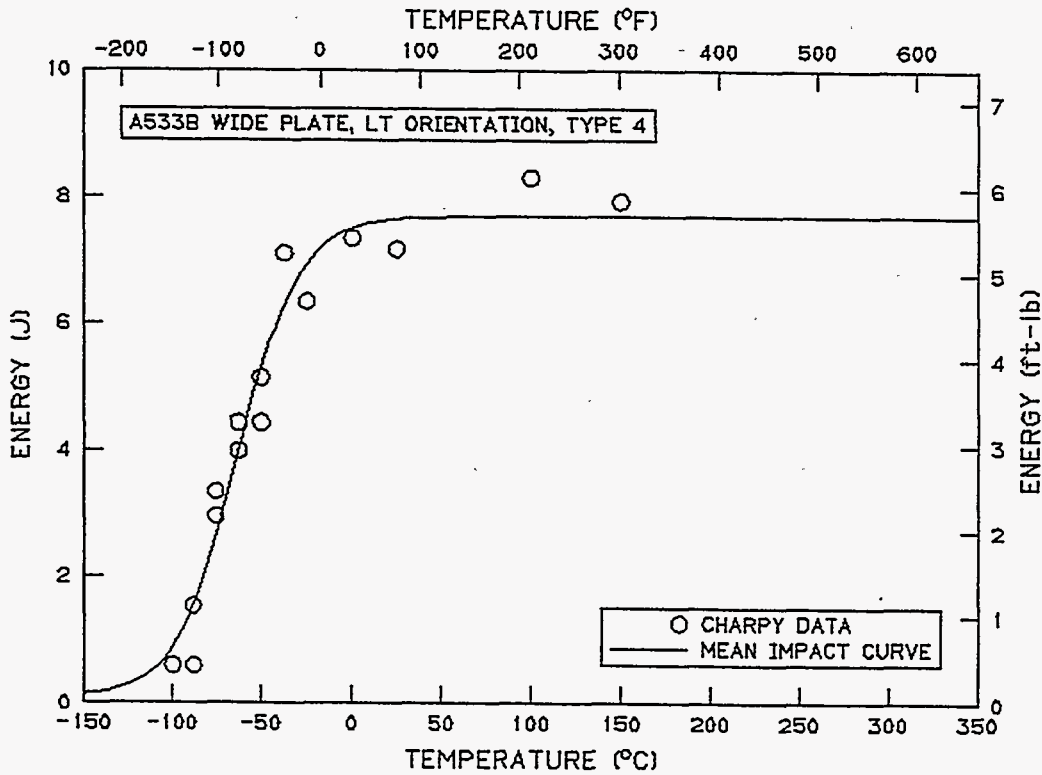

SOURCE: WP_LT.T4 ANALYSIS SET

Y VARIABLE: EXPANSION

MODEL PARAMETERS

LOWER SHELF EXPANSION [HELD FIXED]: 0.000 (MM),0.0000 (IN)

MID-TRANSITION TEMPERATURE:-59.5 (DEG C),-75.0 (DEG F)

TRANSITION ZONE WIDTH: 63.4 (C DEG),114.1 (F DEG)

UPPER SHELF EXPANSION: 0.739 (MM),0.0291 (IN)

UPPER SHELF EXPANSION: 0.739 (MM),0.0291 (IN)

NOTE: NONE

MODEL SET NAME: 5

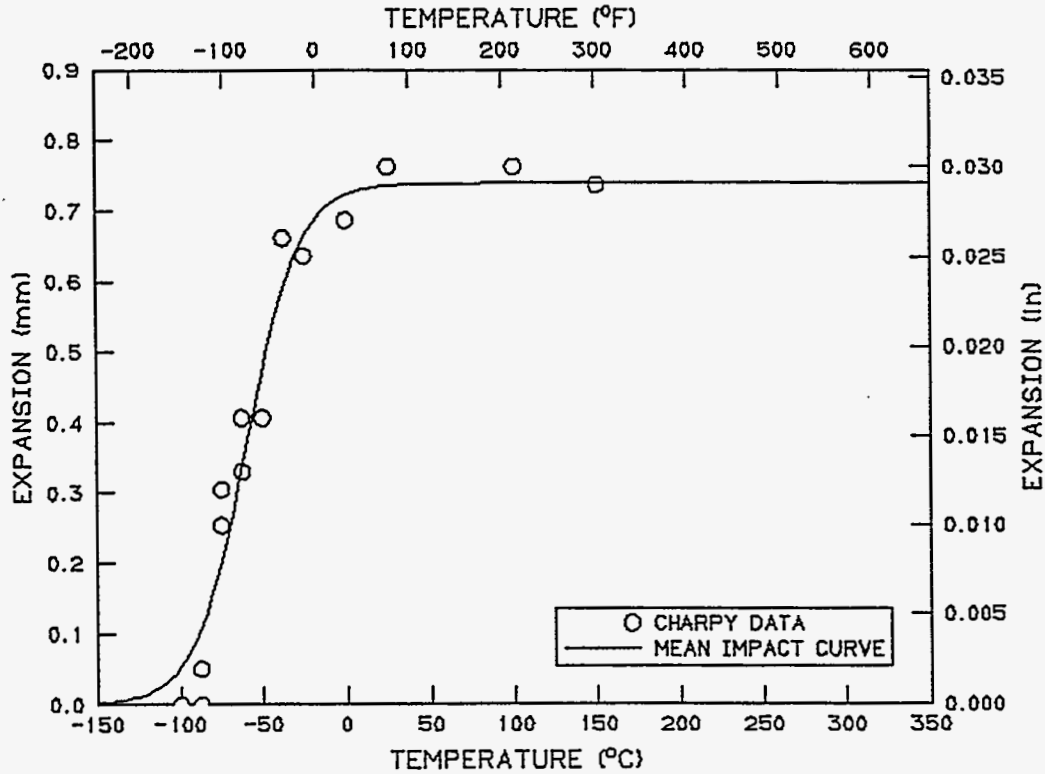

SOURCE: WP_LT.T4 ANALYSIS SET

Y VARIABLE: SHEAR

MODEL PARAMETERS

LOWER SHELF SHEAR [HELD FIXED]: 0 (PERCENT)

MID-TRANSITION TEMPERATURE: -54.3 (DEG C), -65.7 (DEG F)

TRANSITION ZONE WIDTH: 62.9 (C DEG), 113.2 (F DEG)

UPPER SHELF SHEAR [HELD FIXED]: 100 (PERCENT)

UPPER SHELF SHEAR: 100 (PERCENT)

NOTE: NONE

MODEL SET NAME: 4

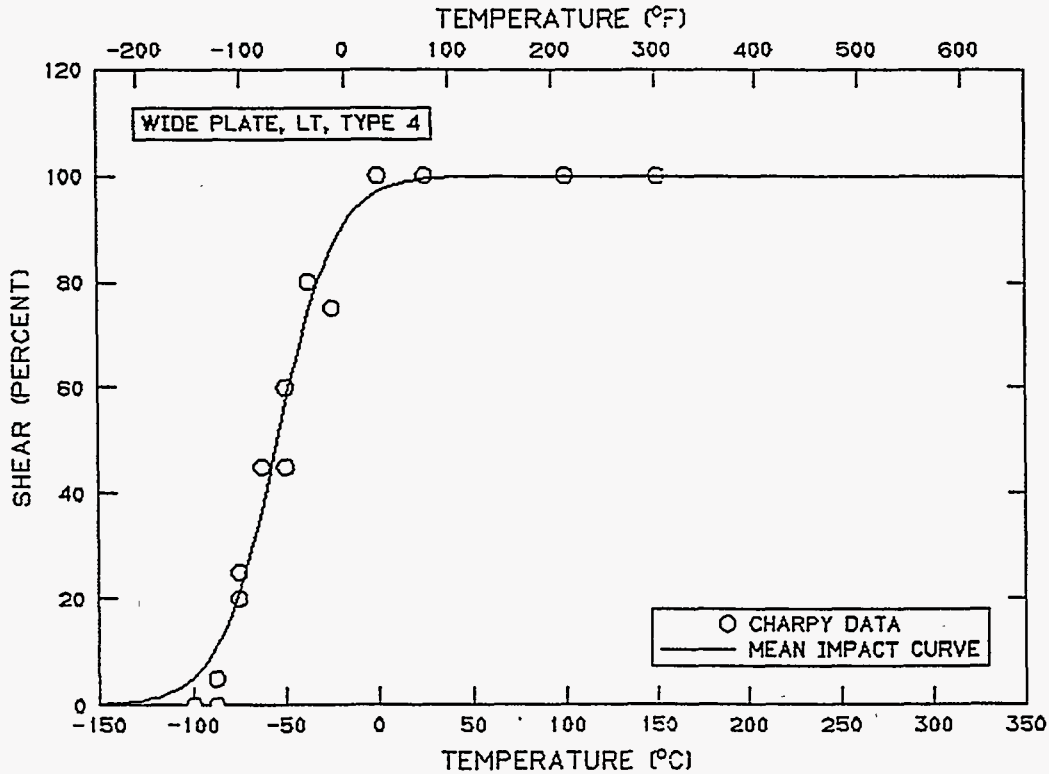

APPENDIX B

A 533 GRADE B WIDE PLATE, TL ORIENTATION

SOURCE: ANALYSIS SET

ANALYSIS SET NAMES: CE_24_TL, CE_23_TL, CE_22_TL AND CE_21_TL

SET NAME: CE_24_TL

NOTE: LAYER 4

IDENT	TEMPERATURE		ENERGY (J)	EXPANSION		SHEAR (PERCENT)	
	(DEG C)	(DEG F)		(MM)	(IN)		
CE2431	-100.0	-148.0	5.00	3.69	0.03	0.001	0.0
CE2440	-75.0	-103.0	12.01	8.85	0.25	0.010	0.0
CE2433	-50.0	-58.0	40.02	29.52	0.64	0.025	3.0
CE2444	-50.0	-58.0	44.02	32.47	0.66	0.026	13.0
CE2446	-25.0	-13.0	79.04	58.29	1.17	0.046	23.0
CE2438	-25.0	-13.0	88.04	64.94	1.24	0.049	16.0
CE2443	-7.0	19.4	107.05	78.96	1.52	0.060	43.0
CE2434	-7.0	19.4	109.05	80.43	1.68	0.066	45.0
CE2450	-7.0	19.4	114.05	84.12	1.60	0.063	42.0
CE2432	0.0	32.0	107.05	78.96	1.47	0.058	52.0
CE2442	0.0	32.0	111.05	81.91	1.55	0.061	43.0
CE2435	23.0	73.4	154.07	113.64	1.98	0.078	67.0
CE2447	23.0	73.4	172.08	126.92	2.11	0.083	76.0
CE2448	50.0	122.0	180.08	132.82	2.13	0.084	100.0
CE2449	50.0	122.0	206.09	152.01	2.31	0.091	100.0
CE2437	75.0	167.0	183.08	135.04	2.16	0.085	100.0
CE2439	75.0	167.0	189.09	139.46	2.21	0.087	100.0
CE2445	100.0	212.0	202.09	149.06	2.13	0.084	100.0
CE2441	150.0	302.0	204.09	150.53	2.11	0.083	100.0
CE2436	200.0	392.0	276.13	203.66	1.93	0.076	100.0

NUMBER OF SPECIMENS: 20

SET NAME: CE_23_TL

NOTE: LAYER 3

IDENT	TEMPERATURE		ENERGY (J)	EXPANSION		SHEAR (PERCENT)	
	(DEG C)	(DEG F)		(MM)	(IN)		
CE2333	-75.0	-103.0	10.00	7.38	0.18	0.007	0.0
CE2346	-50.0	-58.0	17.01	12.54	0.28	0.011	0.0
CE2339	-50.0	-58.0	39.02	28.78	0.61	0.024	11.0
CE2347	-25.0	-13.0	36.02	26.56	0.66	0.026	11.0
CE2336	-25.0	-13.0	80.04	59.03	1.12	0.044	27.0
CE2337	-2.0	28.4	116.05	85.60	1.60	0.063	42.0
CE2331	-2.0	28.4	119.05	87.81	1.68	0.066	45.0
CE2348	-2.0	28.4	128.06	94.45	1.52	0.060	43.0
CE2341	0.0	32.0	102.05	75.27	1.47	0.058	31.0
CE2349	0.0	32.0	112.05	82.64	1.60	0.063	40.0
CE2334	23.0	73.4	150.07	110.68	1.80	0.071	66.0
CE2350	23.0	73.4	155.07	114.37	1.91	0.075	53.0
CE2340	50.0	122.0	192.09	141.68	2.26	0.089	100.0
CE2332	50.0	122.0	201.09	148.32	2.39	0.094	100.0
CE2338	75.0	167.0	195.09	143.89	2.18	0.086	100.0
CE2344	75.0	167.0	212.10	156.43	2.21	0.087	100.0
CE2345	100.0	212.0	201.09	148.32	2.16	0.085	100.0
CE2343	150.0	302.0	206.09	152.01	2.03	0.080	100.0
CE2342	150.0	302.0	296.13	218.42	2.26	0.089	100.0
CE2335	200.0	392.0	320.15	236.13	1.57	0.062	100.0

NUMBER OF SPECIMENS: 20

SET NAME: CE 22_TL

NOTE: LAYER 2

IDENT	TEMPERATURE		ENERGY (J)	(FT-LB)	EXPANSION		SHEAR (PERCENT)
	(DEG C)	(DEG F)			(MM)	(IN)	
CE2233	-75.0	-103.0	7.00	5.17	0.13	0.005	0.0
CE2242	-50.0	-58.0	11.01	8.12	0.23	0.009	0.0
CE2243	-50.0	-58.0	16.01	11.81	0.28	0.011	0.0
CE2247	-25.0	-13.0	46.02	33.94	0.71	0.028	13.0
CE2248	-25.0	-13.0	52.02	38.37	0.74	0.029	18.0
CE2244	-2.0	28.4	97.04	71.58	1.45	0.057	33.0
CE2237	-2.0	28.4	97.04	71.58	1.42	0.056	37.0
CE2238	-2.0	28.4	119.05	87.81	1.65	0.065	43.0
CE2234	0.0	32.0	89.04	65.67	1.30	0.051	33.0
CE2235	0.0	32.0	95.04	70.10	1.45	0.057	38.0
CE2236	23.0	73.4	146.07	107.73	1.93	0.076	62.0
CE2231	23.0	73.4	156.07	115.11	1.83	0.072	50.0
CE2249	50.0	122.0	176.08	129.87	1.96	0.077	79.0
CE2250	50.0	122.0	178.08	131.35	2.08	0.082	92.0
CE2241	75.0	167.0	197.09	145.37	2.21	0.087	100.0
CE2232	75.0	167.0	207.09	152.74	2.21	0.087	100.0
CE2246	100.0	212.0	194.09	143.15	2.18	0.086	100.0
CE2245	150.0	302.0	236.11	174.14	1.96	0.077	100.0
CE2240	150.0	302.0	241.11	177.83	1.91	0.075	100.0
CE2239	200.0	392.0	272.12	200.71	2.01	0.079	100.0

NUMBER OF SPECIMENS: 20

SET NAME: CE 21_TL

NOTE: LAYER 1

IDENT	TEMPERATURE		ENERGY (J)	(FT-LB)	EXPANSION		SHEAR (PERCENT)
	(DEG C)	(DEG F)			(MM)	(IN)	
CE2134	-75.0	-103.0	3.00	2.21	0.08	0.003	0.0
CE2131	-50.0	-58.0	7.00	5.17	0.10	0.004	0.0
CE2143	-50.0	-58.0	9.00	6.64	0.15	0.006	0.0
CE2132	-25.0	-13.0	55.03	40.58	0.86	0.034	13.0
CE2149	-25.0	-13.0	70.03	51.65	0.99	0.039	22.0
CE2135	-2.0	28.4	91.04	67.15	1.42	0.056	29.0
CE2144	-2.0	28.4	104.05	76.74	1.63	0.064	38.0
CE2147	-2.0	28.4	113.05	83.38	1.57	0.062	33.0
CE2138	0.0	32.0	88.04	64.94	1.24	0.049	26.0
CE2141	0.0	32.0	95.04	70.10	1.45	0.057	34.0
CE2140	23.0	73.4	154.07	113.64	2.03	0.080	59.0
CE2150	23.0	73.4	163.07	120.28	2.03	0.080	52.0
CE2145	50.0	122.0	176.08	129.87	2.16	0.085	92.0
CE2137	50.0	122.0	179.08	132.08	2.11	0.083	86.0
CE2146	75.0	167.0	208.09	153.48	2.24	0.088	100.0
CE2133	75.0	167.0	225.10	166.03	2.16	0.085	100.0
CE2136	100.0	212.0	198.09	146.10	2.11	0.083	100.0
CE2142	150.0	302.0	208.09	153.48	2.13	0.084	100.0
CE2148	150.0	302.0	222.10	163.81	1.83	0.072	100.0
CE2139	200.0	392.0	290.13	213.99	1.65	0.065	100.0

NUMBER OF SPECIMENS: 20

SOURCE: CE_24_TL, CE_23_TL, CE_22_TL AND CE_21_TL ANALYSIS SETS

Y VARIABLE: ENERGY

MODEL PARAMETERS

LOWER SHELF ENERGY [HELD FIXED]: 2.7 (J), 2.0 (FT-LB)

MID-TRANSITION TEMPERATURE: 10.0 (DEG C), 50.0 (DEG F)

TRANSITION ZONE WIDTH: 134.9 (C DEG), 242.8 (F DEG)

UPPER SHELF ENERGY: 243.0 (J), 179.2 (FT-LB)

UPPER SHELF ENERGY: 243.0 (J), 179.2 (FT-LB)

TEMPERATURE [41 (J), 30.2 (FT-LB) ENERGY]: -46.1 (DEG C), -50.9 (DEG F)

TEMPERATURE [68 (J), 50.2 (FT-LB) ENERGY]: -23.2 (DEG C), -9.8 (DEG F)

NOTE: NONE

MODEL SET NAME: 8

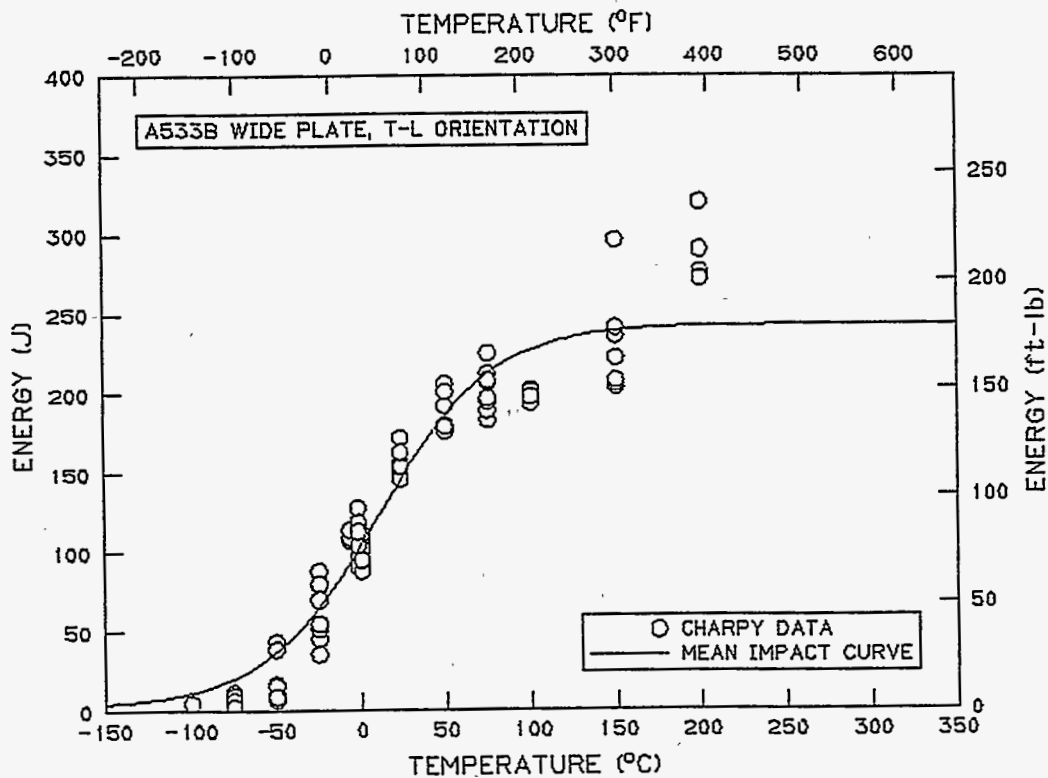

SOURCE: CE_24_TL, CE_23_TL, CE_22_TL AND CE_21_TL ANALYSIS SETS

Y VARIABLE: EXPANSION

MODEL PARAMETERS

LOWER SHELF EXPANSION [HELD FIXED]: 0.061 (MM), 0.0024 (IN)

MID-TRANSITION TEMPERATURE: -19.2 (DEG C), -2.6 (DEG F)

TRANSITION ZONE WIDTH: 71.8 (C DEG), 129.2 (F DEG)

UPPER SHELF EXPANSION: 2.104 (MM), 0.0828 (IN)

UPPER SHELF EXPANSION: 2.104 (MM), 0.0828 (IN)

NOTE: NONE

MODEL SET NAME: 7

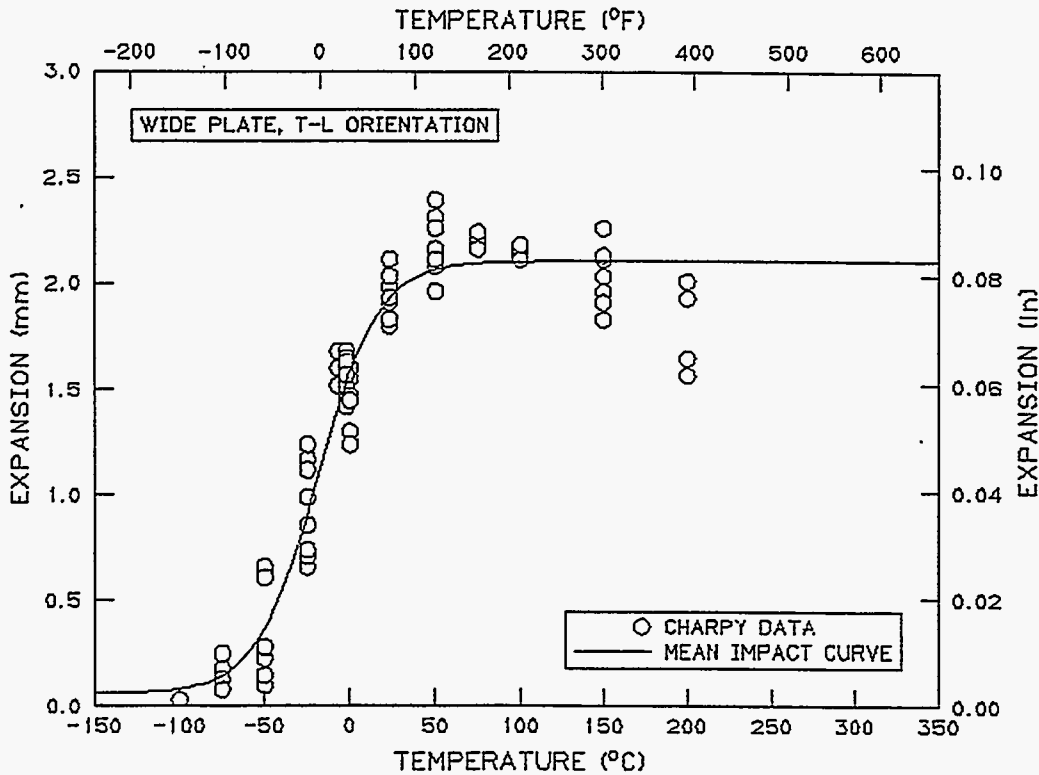

SOURCE: CE_24_TL, CE_23_TL, CE_22_TL AND CE_21_TL ANALYSIS SETS

Y VARIABLE: SHEAR

MODEL PARAMETERS

LOWER SHELF SHEAR [HELD FIXED]: 0 (PERCENT)

MID-TRANSITION TEMPERATURE: 8.6 (DEG C), 47.6 (DEG F)

TRANSITION ZONE WIDTH: 81.8 (C DEG), 147.3 (F DEG)

UPPER SHELF SHEAR [HELD FIXED]: 100 (PERCENT)

UPPER SHELF SHEAR: 100 (PERCENT)

NOTE: NONE

MODEL SET NAME: 6

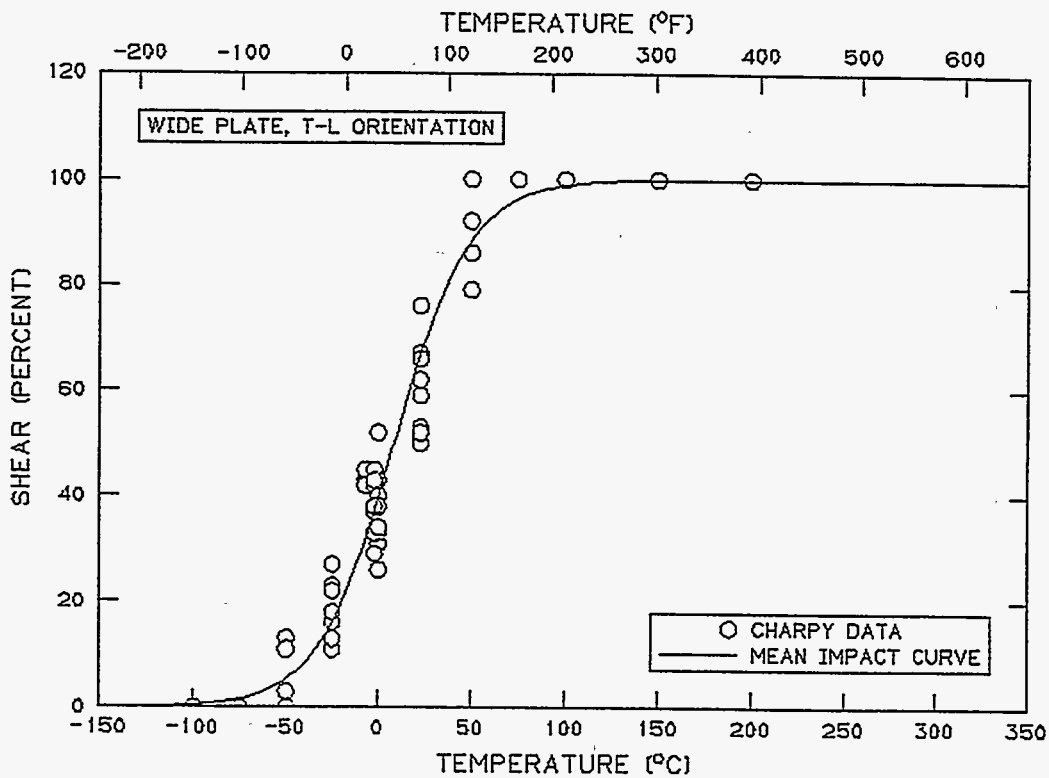

SOURCE: ANALYSIS SET
ANALYSIS SET NAME: WP_TL.T1

SET NAME: WP_TL.T1

NOTE: SUB-SIZE CORREL PROG. - WIDE PLATE, T-L OREINT. - TYPE 1

IDENT	TEMPERATURE		ENERGY (J)	EXPANSION			SHEAR (PERCENT)
	(DEG C)	(DEG F)		(FT-LB)	(MM)	(IN)	
CT35	-100.0	-148.0	0.81	0.60	0.00	0.000	0.0
CT36	-87.5	-125.5	0.95	0.70	0.00	0.000	0.0
CT34	-75.0	-103.0	8.13	6.00	0.25	0.010	15.0
CT38	-62.5	-80.5	6.24	4.60	0.23	0.009	10.0
CT7	-62.5	-80.5	UNKNOWN		0.71	0.028	40.0
CT39	-50.0	-58.0	10.44	7.70	0.41	0.016	35.0
CT40	-37.5	-35.5	18.57	13.70	0.86	0.034	60.0
CT41	-25.0	-13.0	20.07	14.80	0.91	0.036	60.0
CT42	-12.5	9.5	18.71	13.80	0.86	0.034	70.0
CT43	0.0	32.0	24.81	18.30	1.02	0.040	80.0
CT46	12.5	54.5	30.91	22.80	0.99	0.039	100.0
CT44	25.0	77.0	33.35	24.60	1.04	0.041	100.0
CT45	100.0	212.0	29.42	21.70	0.99	0.039	100.0
CT33	200.0	392.0	37.69	27.80	0.58	0.023	100.0

NUMBER OF SPECIMENS: 14

SOURCE: WP_TL.T1 ANALYSIS SET

Y VARIABLE: ENERGY

MODEL PARAMETERS

LOWER SHELF ENERGY [HELD FIXED]: 0.1 (J), 0.1 (FT-LB)

MID-TRANSITION TEMPERATURE: -30.7 (DEG C), -23.3 (DEG F)

TRANSITION ZONE WIDTH: 101.6 (C DEG), 182.8 (F DEG)

UPPER SHELF ENERGY: 34.3 (J), 25.3 (FT-LB)

UPPER SHELF ENERGY: 34.3 (J), 25.3 (FT-LB)

NOTE: NONE

MODEL SET NAME: 7

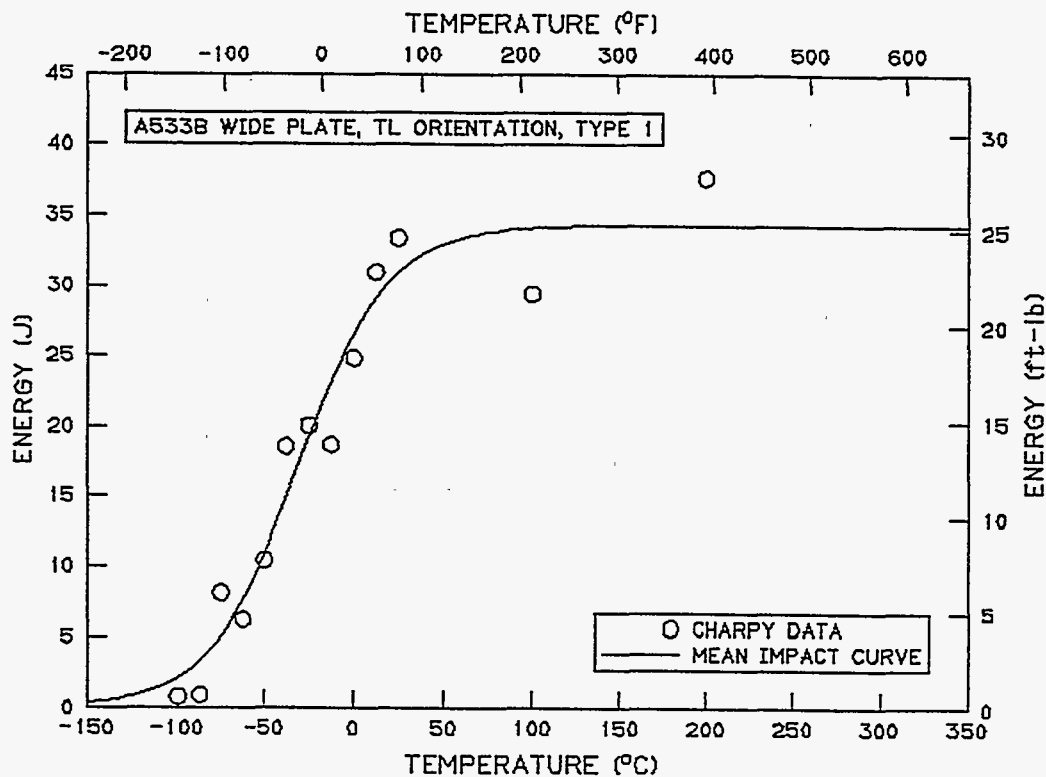

SOURCE: WP_TL.T1 ANALYSIS SET

Y VARIABLE: EXPANSION

MODEL PARAMETERS

LOWER SHELF EXPANSION [HELD FIXED]: 0.000 (MM), 0.0000 (IN)

MID-TRANSITION TEMPERATURE: -55.9 (DEG C), -68.7 (DEG F)

TRANSITION ZONE WIDTH: 59.1 (C DEG), 106.4 (F DEG)

UPPER SHELF EXPANSION [HELD FIXED]: 1.000 (MM), 0.0394 (IN)

UPPER SHELF EXPANSION: 1.000 (MM), 0.0394 (IN)

NOTE: NONE

MODEL SET NAME: 9

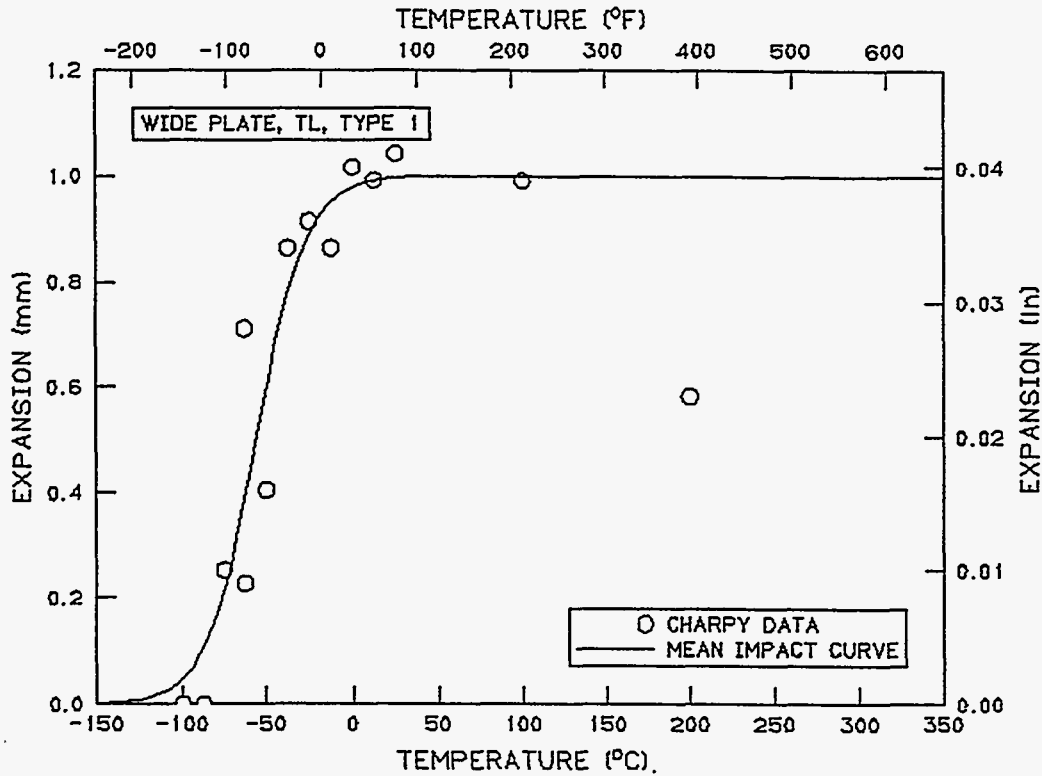

SOURCE: WP_TL.T1 ANALYSIS SET

Y VARIABLE: SHEAR

MODEL PARAMETERS

LOWER SHELF SHEAR [HELD FIXED]: 0 (PERCENT)

MID-TRANSITION TEMPERATURE: -37.6 (DEG C), -35.7 (DEG F)

TRANSITION ZONE WIDTH: 83.2 (C DEG), 149.7 (F DEG)

UPPER SHELF SHEAR [HELD FIXED]: 100 (PERCENT)

UPPER SHELF SHEAR: 100 (PERCENT)

NOTE: NONE

MODEL SET NAME: 0

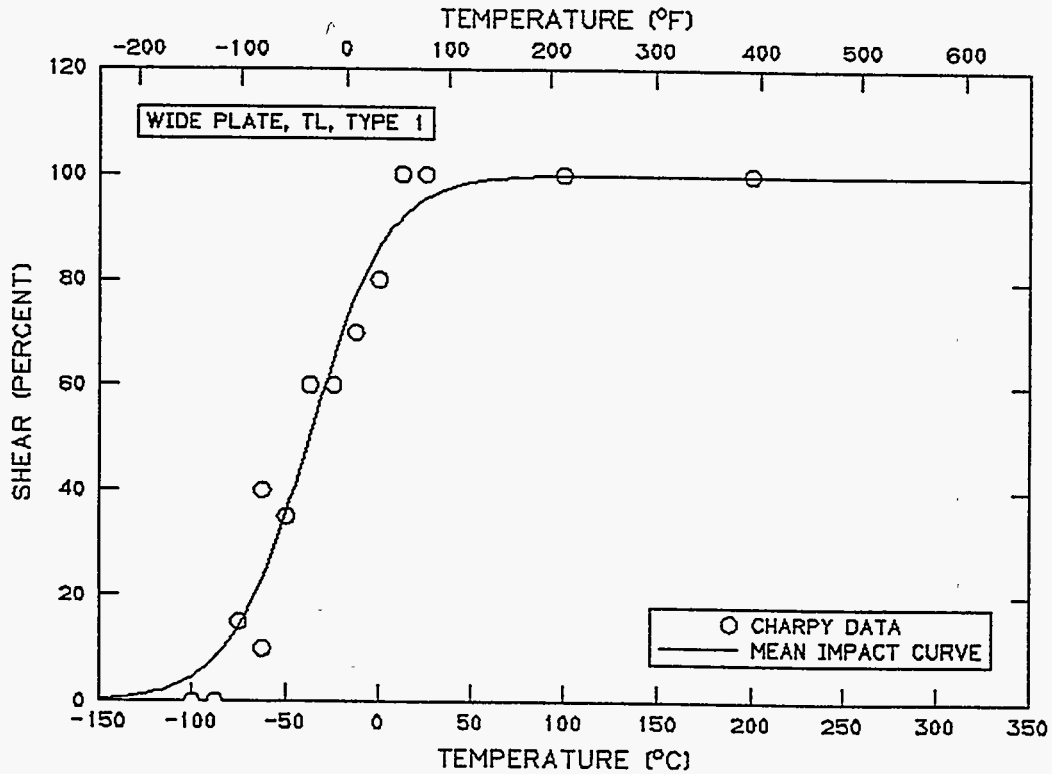

SOURCE: ANALYSIS SET
ANALYSIS SET NAME: WP_TL.T2

SET NAME: WP_TL.T2

NOTE: WIDE PLATE TYPE 2 SPECIMENS IN THE T-L ORIENTATION

IDENT	TEMPERATURE		ENERGY (J)	EXPANSION			SHEAR (PERCENT)
	(DEG C)	(DEG F)		(FT-LB)	(MM)	(IN)	
CT2	-125.0	-193.0	0.14	0.10	0.00	0.000	0.0
CT15	-112.5	-170.5	0.14	0.10	0.00	0.000	0.0
CT3	-112.0	-169.6	2.03	1.50	0.13	0.005	0.0
CT1	-100.0	-148.0	1.49	1.10	0.00	0.000	0.0
CT16	-100.0	-148.0	0.95	0.70	0.03	0.001	0.0
CT4	-87.5	-125.5	2.44	1.80	0.15	0.006	5.0
CT5	-75.0	-103.0	4.47	3.30	0.30	0.012	15.0
CT6	-62.5	-80.5	5.02	3.70	0.43	0.017	40.0
CT7	-50.0	-58.0	7.59	5.60	0.53	0.021	UNKNOWN
CT8	-37.5	-35.5	8.95	6.60	0.66	0.026	UNKNOWN
CT9	-25.0	-13.0	7.32	5.40	0.51	0.020	UNKNOWN
CT10	-12.5	9.5	8.41	6.20	0.64	0.025	UNKNOWN
CT11	0.0	32.0	9.08	6.70	0.71	0.028	UNKNOWN
CT12	50.0	122.0	9.36	6.90	0.79	0.031	100.0
CT13	100.0	212.0	8.54	6.30	0.69	0.027	100.0
CT14	150.0	302.0	8.81	6.50	0.71	0.028	100.0

NUMBER OF SPECIMENS: 16

SOURCE: WP_TL.T2 ANALYSIS SET

Y VARIABLE: ENERGY

MODEL PARAMETERS

LOWER SHELF ENERGY [HELD FIXED]: 0.1 (J), 0.1 (FT-LB)

MID-TRANSITION TEMPERATURE: -72.3 (DEG C), -98.2 (DEG F)

TRANSITION ZONE WIDTH: 62.9 (C DEG), 113.3 (F DEG)

UPPER SHELF ENERGY: 8.9 (J), 6.5 (FT-LB)

UPPER SHELF ENERGY: 8.9 (J), 6.5 (FT-LB)

NOTE: NONE

MODEL SET NAME: 3

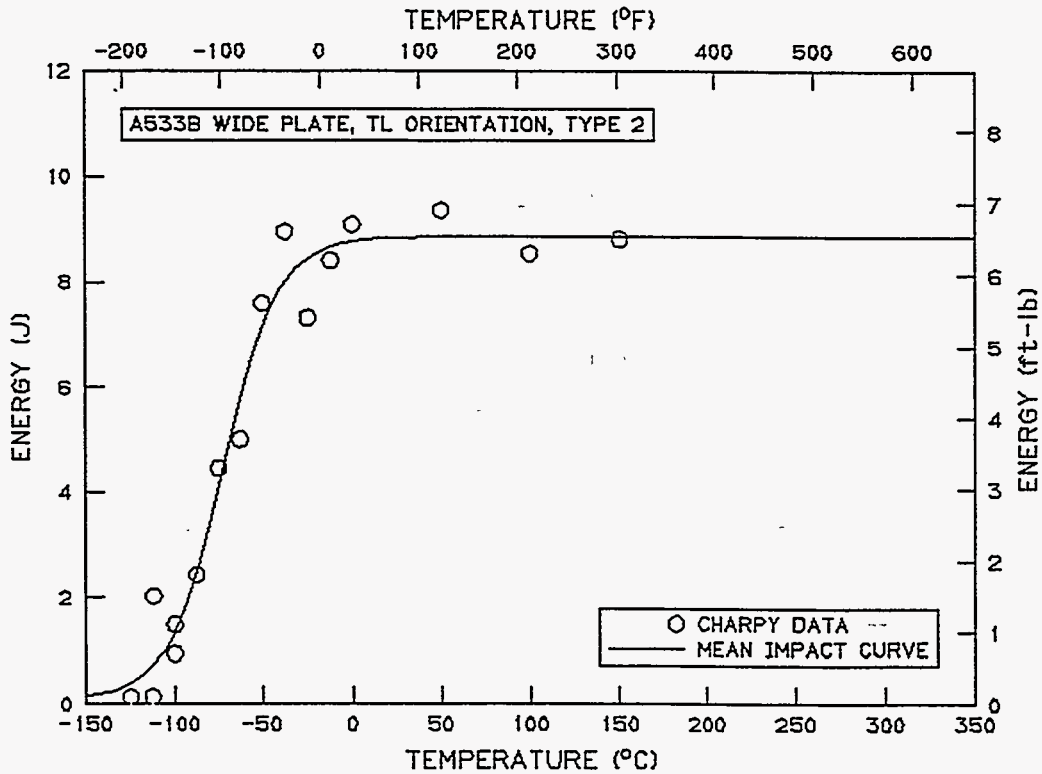

SOURCE: WP_TL.T2 ANALYSIS SET

Y VARIABLE: EXPANSION

MODEL PARAMETERS

LOWER SHELF EXPANSION [HELD FIXED]: 0.000 (MM), 0.0000 (IN)

MID-TRANSITION TEMPERATURE: -68.3 (DEG C), -91.0 (DEG F)

TRANSITION ZONE WIDTH: 59.4 (C DEG), 106.9 (F DEG)

UPPER SHELF EXPANSION: 0.693 (MM), 0.0273 (IN)

UPPER SHELF EXPANSION: 0.693 (MM), 0.0273 (IN)

NOTE: NONE

MODEL SET NAME: 2

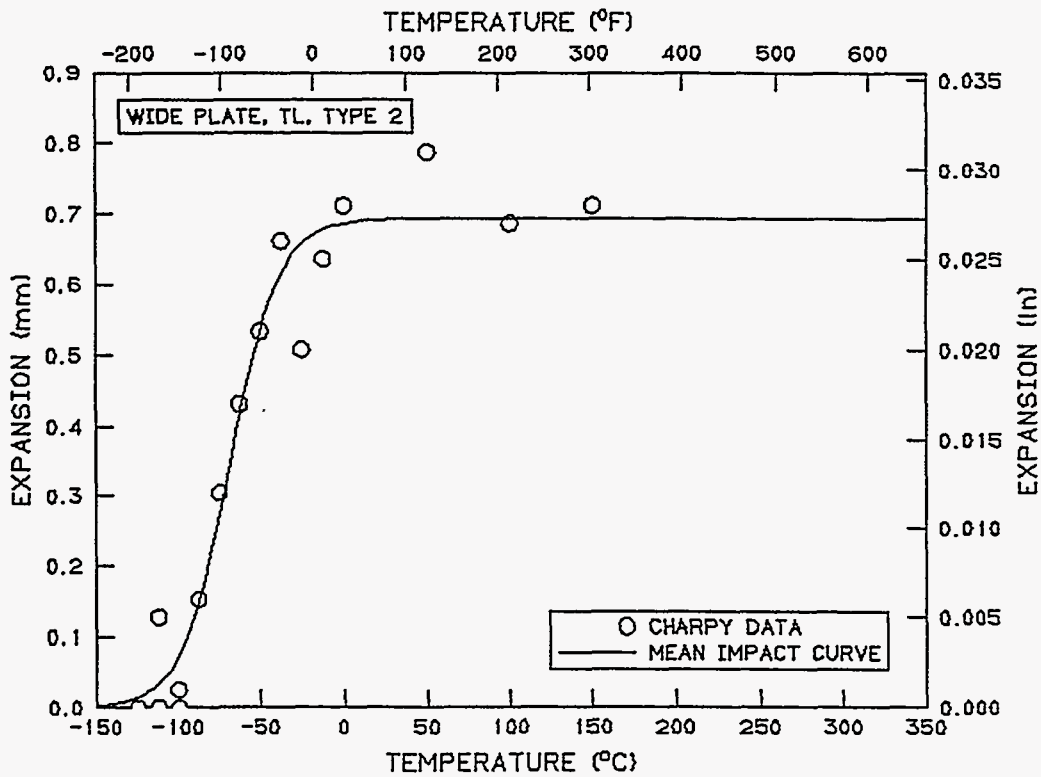

SOURCE: WP_TL.T2 ANALYSIS SET

Y VARIABLE: SHEAR

MODEL PARAMETERS

LOWER SHELF SHEAR [HELD FIXED]: 0 (PERCENT)

MID-TRANSITION TEMPERATURE: -58.8 (DEG C), -73.8 (DEG F)

TRANSITION ZONE WIDTH: 37.0 (C DEG), 66.6 (F DEG)

UPPER SHELF SHEAR [HELD FIXED]: 100 (PERCENT)

UPPER SHELF SHEAR: 100 (PERCENT)

NOTE: NONE

MODEL SET NAME: 1

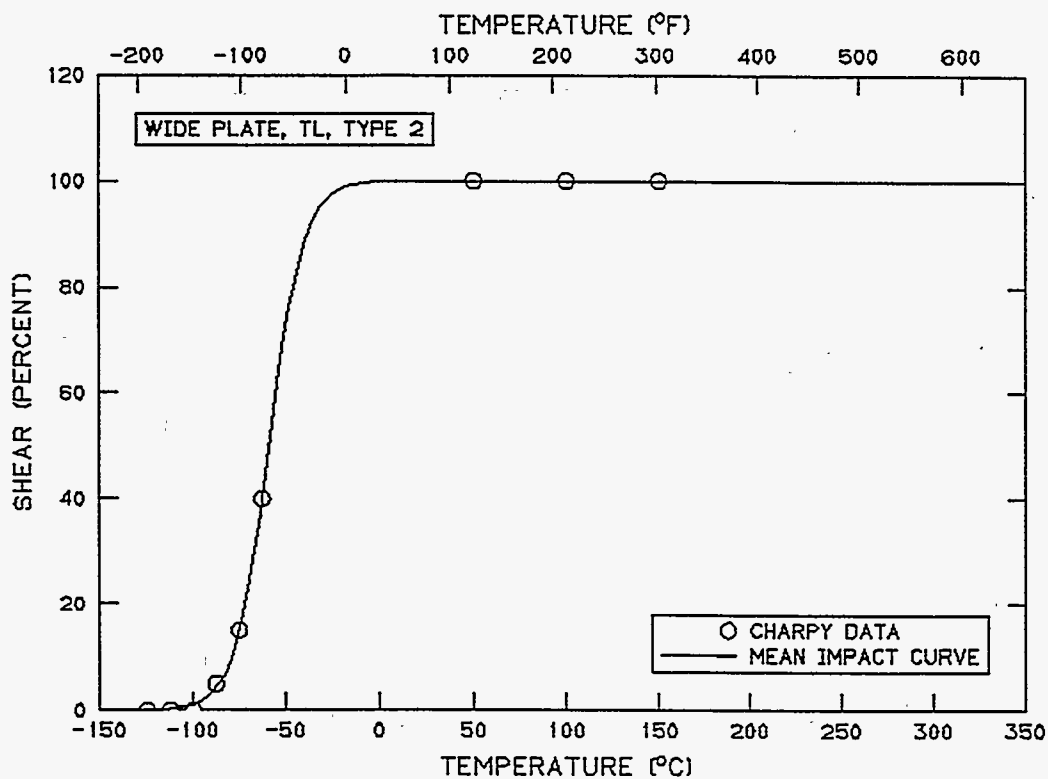

SOURCE: ANALYSIS SET
ANALYSIS SET NAME: WP_TL.T3A

SET NAME: WP_TL.T3A
NOTE: WIDE PLATE, T-L ORIENTATION, TYPE 3

IDENT	TEMPERATURE		ENERGY		EXPANSION		SHEAR (PERCENT)
	(DEG C)	(DEG F)	(J)	(FT-LB)	(MM)	(IN)	
CT50	-125.0	-193.0	0.81	0.60	0.00	0.000	0.0
CT49	-112.5	-170.5	1.22	0.90	0.00	0.000	0.0
CT48	-100.0	-148.0	7.59	5.60	0.33	0.013	5.0
CT51	-87.5	-125.5	7.59	5.60	0.33	0.013	5.0
CT52	-75.0	-103.0	10.17	7.50	0.51	0.020	10.0
CT53	-62.5	-80.5	11.93	8.80	0.58	0.023	20.0
CT54	-50.0	-58.0	14.37	10.60	0.66	0.026	50.0
CT60	-25.0	-13.0	18.57	13.70	0.86	0.034	55.0
CT59	0.0	32.0	22.51	16.60	0.84	0.033	75.0
CT55	25.0	77.0	30.37	22.40	0.97	0.038	100.0
CT58	50.0	122.0	34.44	25.40	0.97	0.038	100.0
CT56	100.0	212.0	38.64	28.50	0.74	0.029	100.0
CT62	100.0	212.0	28.74	21.20	0.84	0.033	100.0
CT61	150.0	302.0	36.20	26.70	0.76	0.030	100.0

NUMBER OF SPECIMENS: 14

SOURCE: WP_TL.T3A ANALYSIS SET

Y VARIABLE: ENERGY

MODEL PARAMETERS

LOWER SHELF ENERGY [HELD FIXED]: 0.1 (J), 0.1 (FT-LB)

MID-TRANSITION TEMPERATURE: -31.8 (DEG C), -25.2 (DEG F)

TRANSITION ZONE WIDTH: 154.9 (C DEG), 278.8 (F DEG)

UPPER SHELF ENERGY: 35.9 (J), 26.5 (FT-LB)

UPPER SHELF ENERGY: 35.9 (J), 26.5 (FT-LB)

NOTE: NONE

MODEL SET NAME: 5

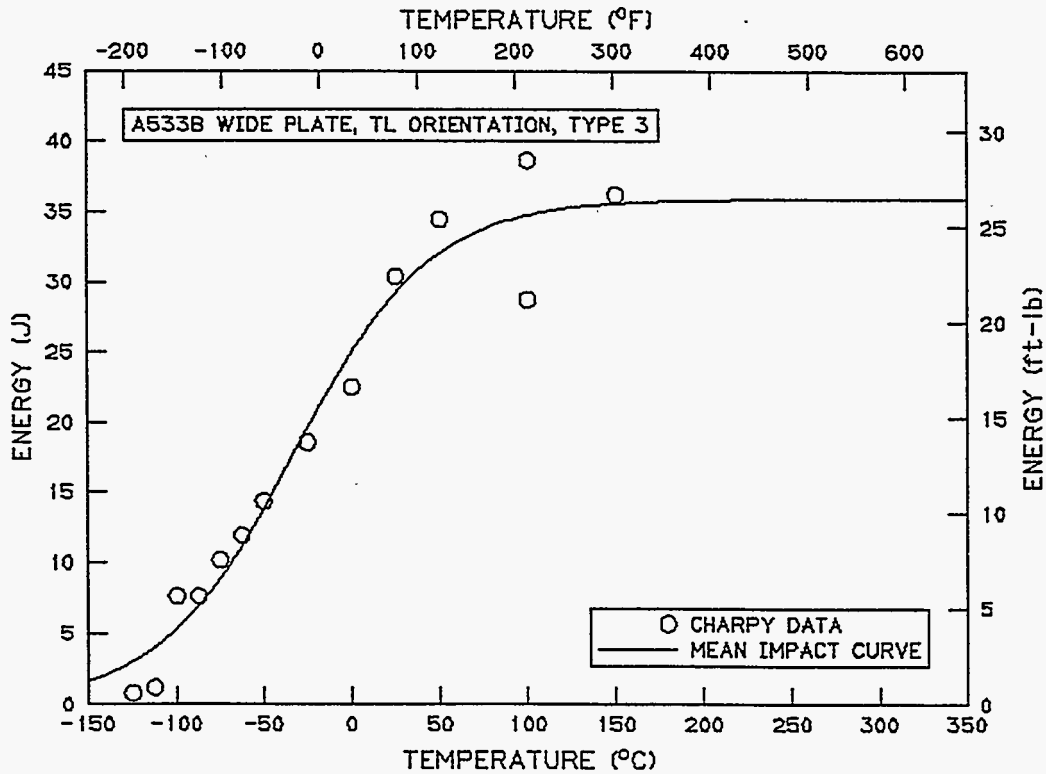

SOURCE: WP_TL.T3A ANALYSIS SET

Y VARIABLE: EXPANSION

MODEL PARAMETERS

LOWER SHELF EXPANSION [HELD FIXED]: 0.000 (MM), 0.0000 (IN)

MID-TRANSITION TEMPERATURE: -79.5 (DEG C), -111.2 (DEG F)

TRANSITION ZONE WIDTH: 70.9 (C DEG), 127.6 (F DEG)

UPPER SHELF EXPANSION: 0.853 (MM), 0.0336 (IN)

UPPER SHELF EXPANSION: 0.853 (MM), 0.0336 (IN)

NOTE: NONE

MODEL SET NAME: 7

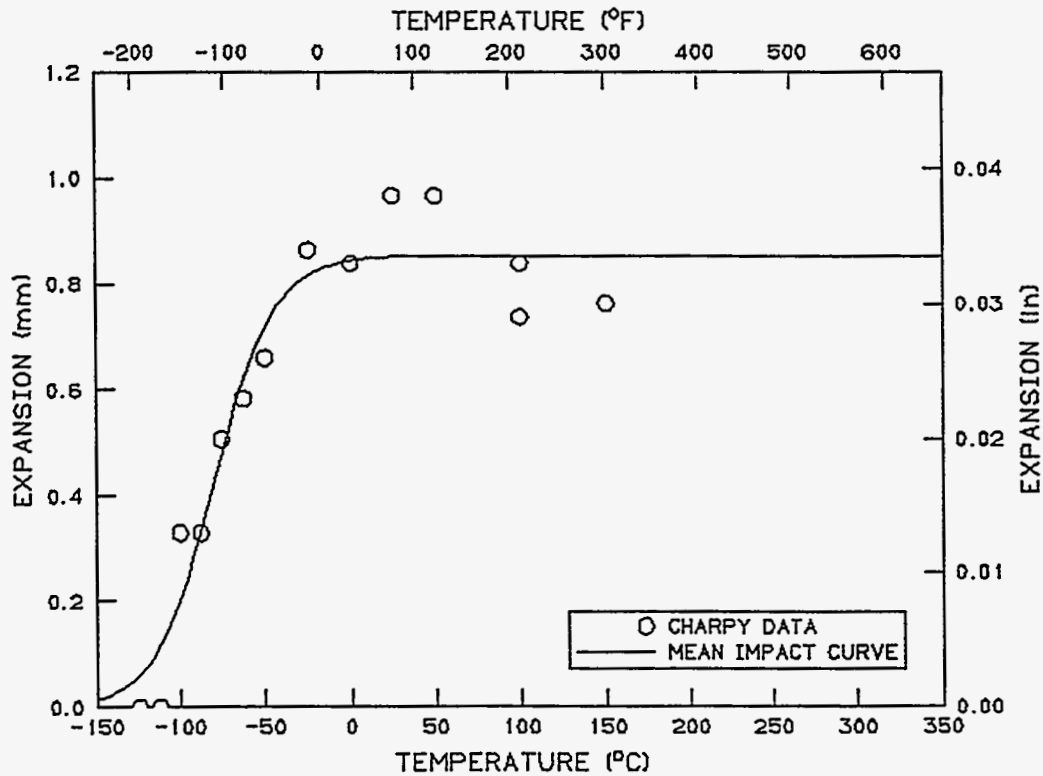

SOURCE: WP_TL.T3A ANALYSIS SET

Y VARIABLE: SHEAR

MODEL PARAMETERS

LOWER SHELF SHEAR [HELD FIXED]: 0 (PERCENT)

MID-TRANSITION TEMPERATURE: -34.2 (DEG C), -29.5 (DEG F)

TRANSITION ZONE WIDTH: 93.4 (C DEG), 168.2 (F DEG)

UPPER SHELF SHEAR: 101 (PERCENT)

UPPER SHELF SHEAR: 101 (PERCENT)

NOTE: NONE

MODEL SET NAME: 8

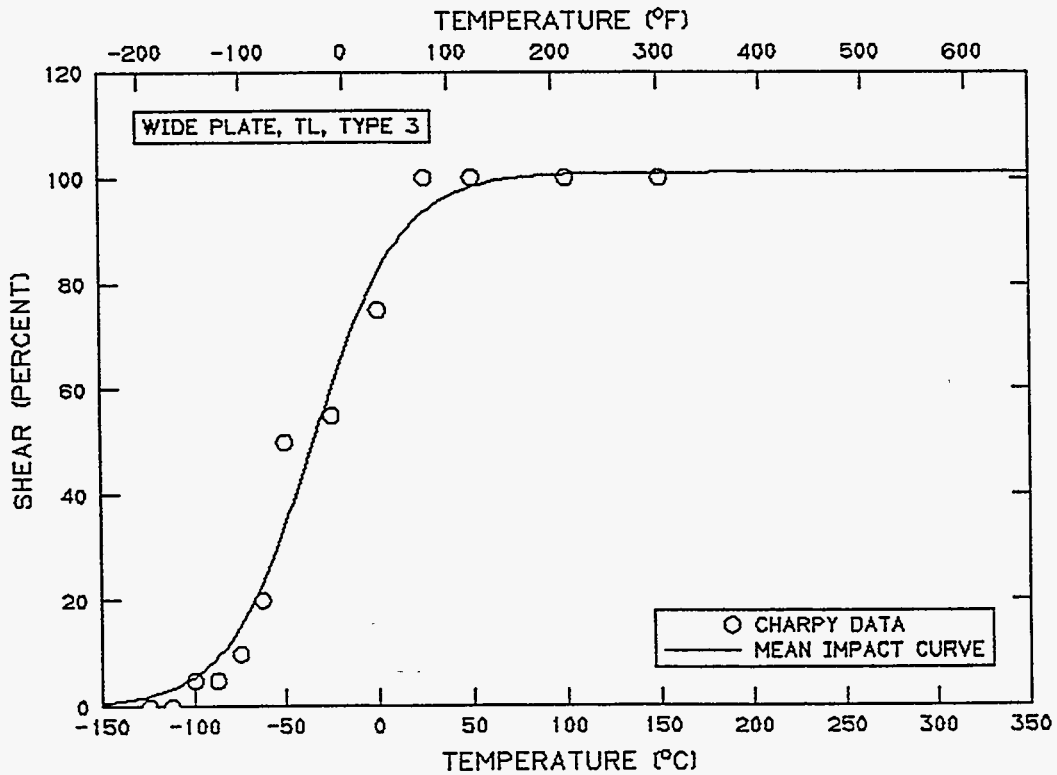

SOURCE: ANALYSIS SET
 ANALYSIS SET NAME: WP_TL.T4

SET NAME: WP_TL.T4

NOTE: SUB-SIZE CORRELATION PROG., WIDE PLATE, T-L ORIENT., TYPE 4

IDENT	TEMPERATURE		ENERGY		EXPANSION		SHEAR (PERCENT)
	(DEG C)	(DEG F)	(J)	(FT-LB)	(MM)	(IN)	
CT27	-100.0	-148.0	0.20	0.15	0.00	0.000	0.0
CT26	-87.5	-125.5	0.33	0.24	0.00	0.000	0.0
CT21	-75.0	-103.0	2.36	1.74	0.20	0.008	10.0
CT28	-75.0	-103.0	1.57	1.16	0.13	0.005	5.0
CT25	-62.5	-80.5	3.53	2.60	0.23	0.009	30.0
CT29	-62.5	-80.5	2.56	1.89	0.20	0.008	10.0
CT20	-50.0	-58.0	4.37	3.22	0.41	0.016	45.0
CT30	-50.0	-58.0	4.81	3.55	0.43	0.017	55.0
CT24	-37.5	-35.5	6.03	4.45	0.53	0.021	75.0
CT19	-25.0	-13.0	6.40	4.72	0.58	0.023	80.0
CT23	-12.5	9.5	7.86	5.80	0.69	0.027	100.0
CT18	0.0	32.0	6.47	4.77	0.61	0.024	80.0
CT17	25.0	77.0	6.85	5.05	0.64	0.025	100.0
CT22	100.0	212.0	7.43	5.48	0.71	0.028	100.0
CT31	150.0	302.0	7.36	5.43	0.79	0.031	100.0

NUMBER OF SPECIMENS: 15

SOURCE: WP_TL.T4 ANALYSIS SET

Y VARIABLE: ENERGY

MODEL PARAMETERS

LOWER SHELF ENERGY [HELD FIXED]: 0.1 (J), 0.1 (FT-LB)

MID-TRANSITION TEMPERATURE: -58.1 (DEG C), -72.6 (DEG F)

TRANSITION ZONE WIDTH: 53.7 (C DEG), 96.7 (F DEG)

UPPER SHELF ENERGY: 7.2 (J), 5.3 (FT-LB)

UPPER SHELF ENERGY: 7.2 (J), 5.3 (FT-LB)

NOTE: NONE

MODEL SET NAME: 1

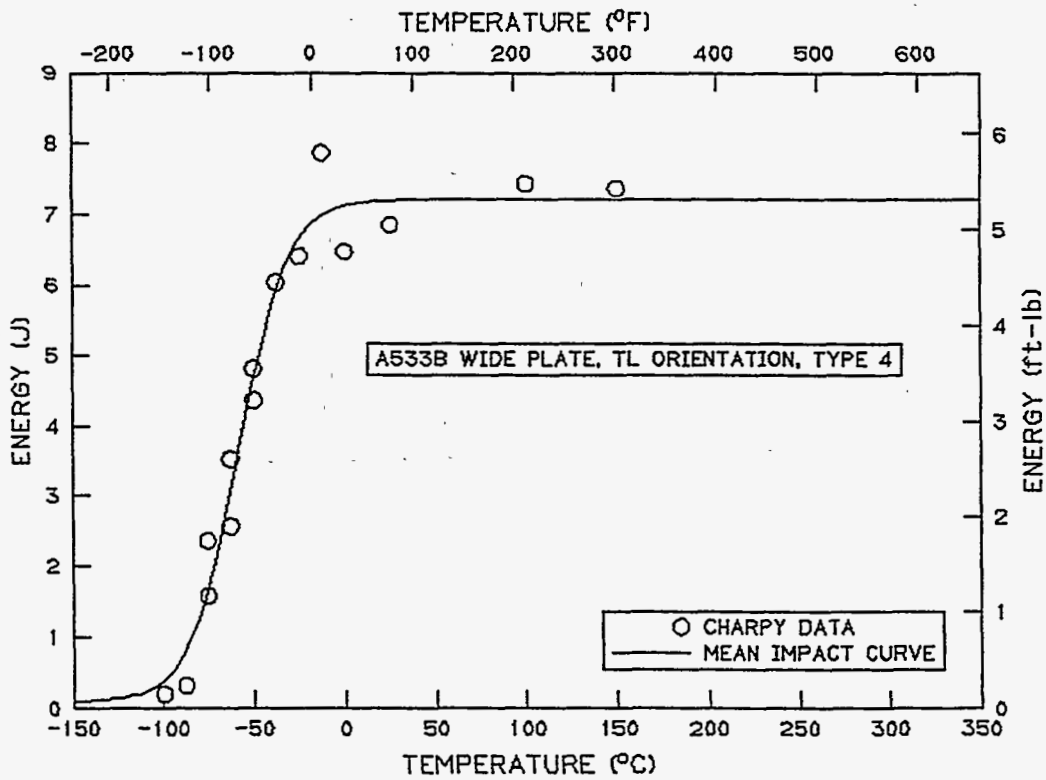

SOURCE: WP_TL.T4 ANALYSIS SET

Y VARIABLE: EXPANSION

MODEL PARAMETERS

LOWER SHELF EXPANSION [HELD FIXED]: 0.000 (MM), 0.0000 (IN)

MID-TRANSITION TEMPERATURE: -54.1 (DEG C), -65.3 (DEG F)

TRANSITION ZONE WIDTH: 56.3 (C DEG), 101.3 (F DEG)

UPPER SHELF EXPANSION: 0.694 (MM), 0.0273 (IN)

UPPER SHELF EXPANSION: 0.694 (MM), 0.0273 (IN)

NOTE: NONE

MODEL SET NAME: 0

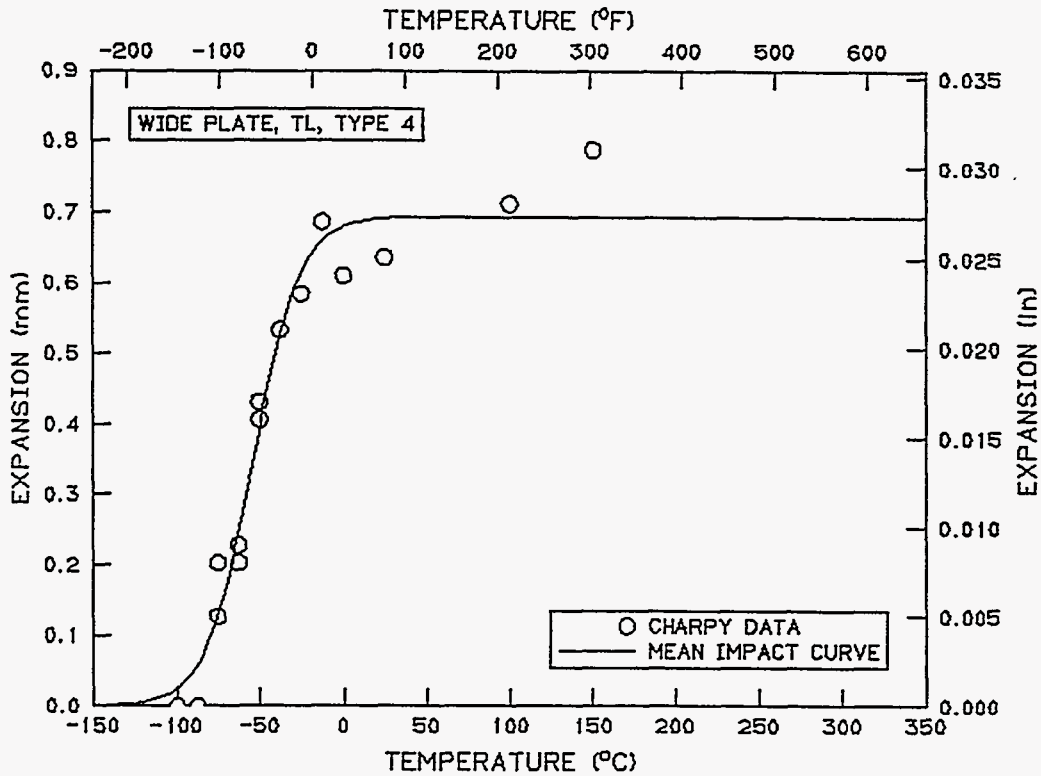

SOURCE: WP_TL.T4 ANALYSIS SET

Y VARIABLE: SHEAR

MODEL PARAMETERS

LOWER SHELF SHEAR [HELD FIXED]: 0 (PERCENT)

MID-TRANSITION TEMPERATURE: -48.4 (DEG C), -55.2 (DEG F)

TRANSITION ZONE WIDTH: 45.8 (C DEG), 82.4 (F DEG)

UPPER SHELF SHEAR [HELD FIXED]: 100 (PERCENT)

UPPER SHELF SHEAR: 100 (PERCENT)

NOTE: NONE

MODEL SET NAME: 9

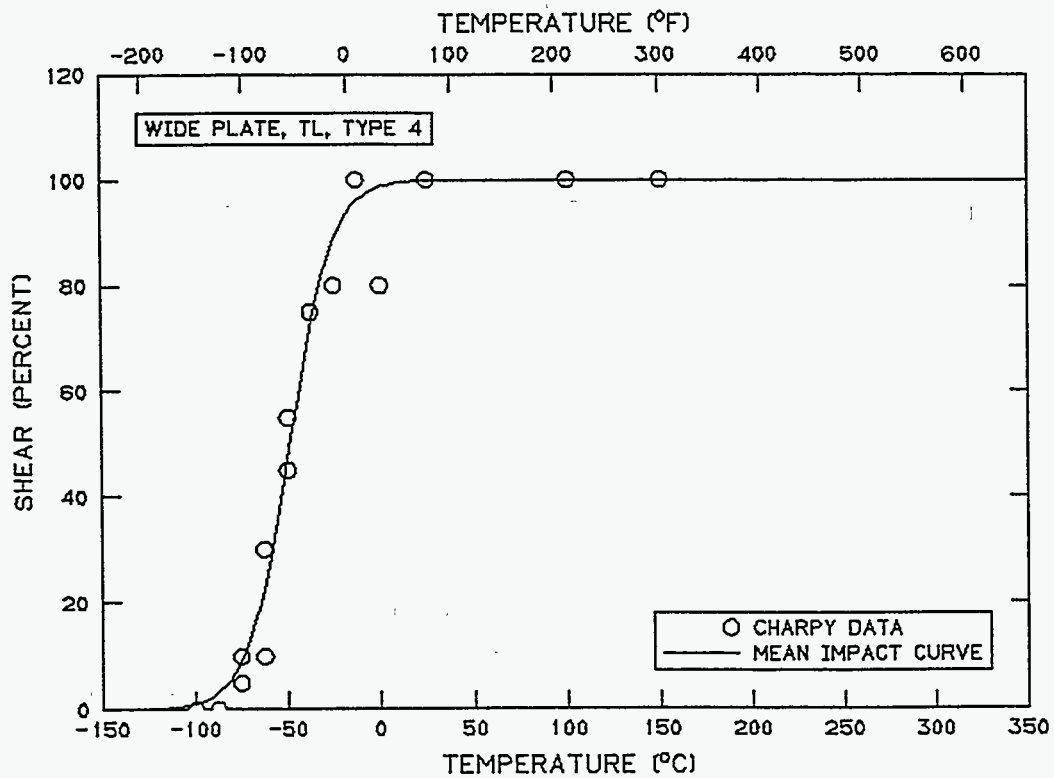

APPENDIX C
A 508, AS QUENCHED

SOURCE: ANALYSIS SET
ANALYSIS SET NAME: 508_QUEN.F

SET NAME: 508_QUEN.F

NOTE: A508, QUENCHED ONLY, FULL-SIZE

IDENT	TEMPERATURE		ENERGY (J)	(FT-LB)	EXPANSION		SHEAR (PERCENT)
	(DEG C)	(DEG F)			(MM)	(IN)	
7SC-8	21.0	69.8	21.00	15.49	0.20	0.008	0.0
7SC-18	43.0	109.4	29.00	21.39	0.48	0.019	15.0
7SC-10	66.0	150.8	47.00	34.67	0.69	0.027	30.0
7SC-14	99.0	210.2	64.00	47.20	0.93	0.037	75.0
7SC-22	104.0	219.2	86.00	63.43	1.22	0.048	80.0
7SC-20	110.0	230.0	103.00	75.97	1.45	0.057	95.0
7SC-12	121.0	249.8	103.00	75.97	1.47	0.058	100.0
7SC-16	177.0	350.6	108.00	79.66	1.57	0.062	100.0

NUMBER OF SPECIMENS: 8

ANALYSIS SET: 508_QUEN.F

Y VARIABLE: ENERGY

TANH REGRESSION NOT CONVERGING AFTER 13 ITERATION(S)

MODEL PARAMETERS

LOWER SHELF ENERGY [HELD FIXED]: 2.7 (J), 2.0 (FT-LB)

MID-TRANSITION TEMPERATURE: 76.7 (DEG C), 170.0 (DEG F)

TRANSITION ZONE WIDTH: 110.1 (C DEG), 198.2 (F DEG)

UPPER SHELF ENERGY: 115.6 (J), 85.3 (FT-LB)

UPPER SHELF ENERGY: 115.6 (J), 85.3 (FT-LB)

TEMPERATURE [41 (J), 30.2 (FT-LB) ENERGY]: 58.3 (DEG C), 137.0 (DEG F)

TEMPERATURE [68 (J), 50.2 (FT-LB) ENERGY]: 85.4 (DEG C), 185.7 (DEG F)

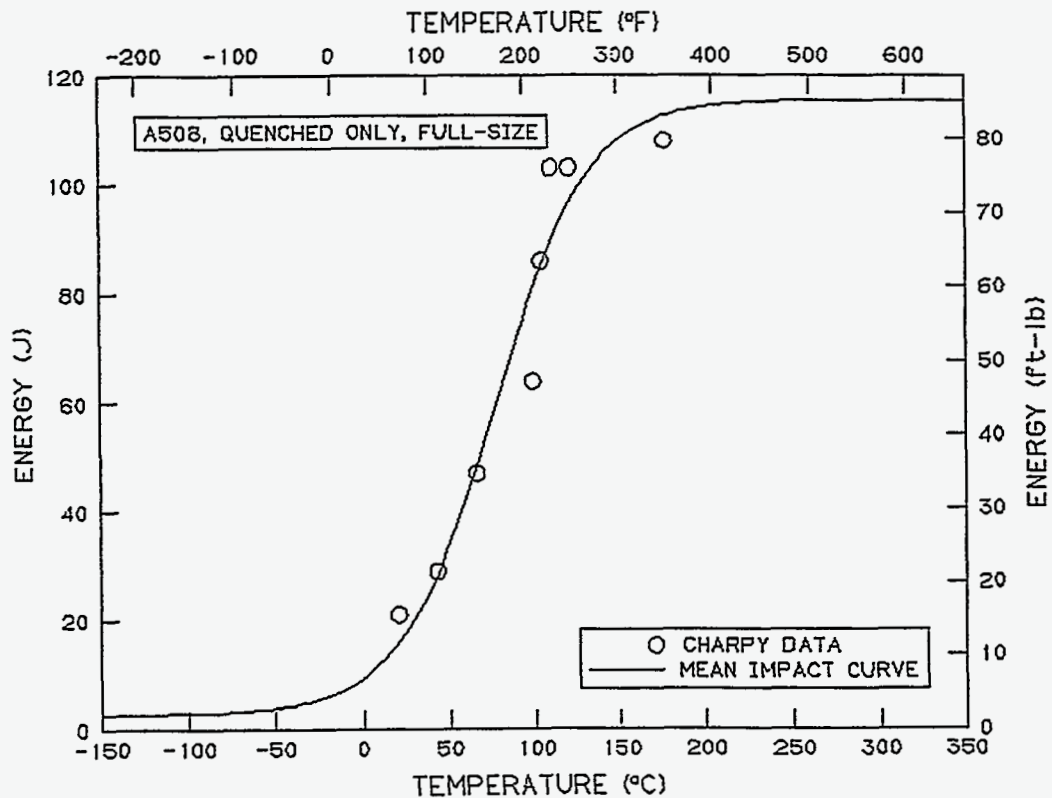

NOTE: A508, QUENCHED ONLY, FULL-SIZE
MODEL SET NAME: 508_QUEN.F

ANALYSIS SET: 508_QUEN.F

Y VARIABLE: EXPANSION

MODEL PARAMETERS

LOWER SHELF EXPANSION [HELD FIXED]: 0.061 (MM), 0.0024 (IN)
MID-TRANSITION TEMPERATURE: 77.8 (DEG C), 172.1 (DEG F)
TRANSITION ZONE WIDTH: 107.9 (C DEG), 194.2 (F DEG)
UPPER SHELF EXPANSION: 1.659 (MM), 0.0653 (IN)
UPPER SHELF EXPANSION: 1.659 (MM), 0.0653 (IN)
TEMPERATURE [0.89 (MM), 0.035 (IN) EXPANSION]: 79.9 (DEG C), 175.8 (DEG F)

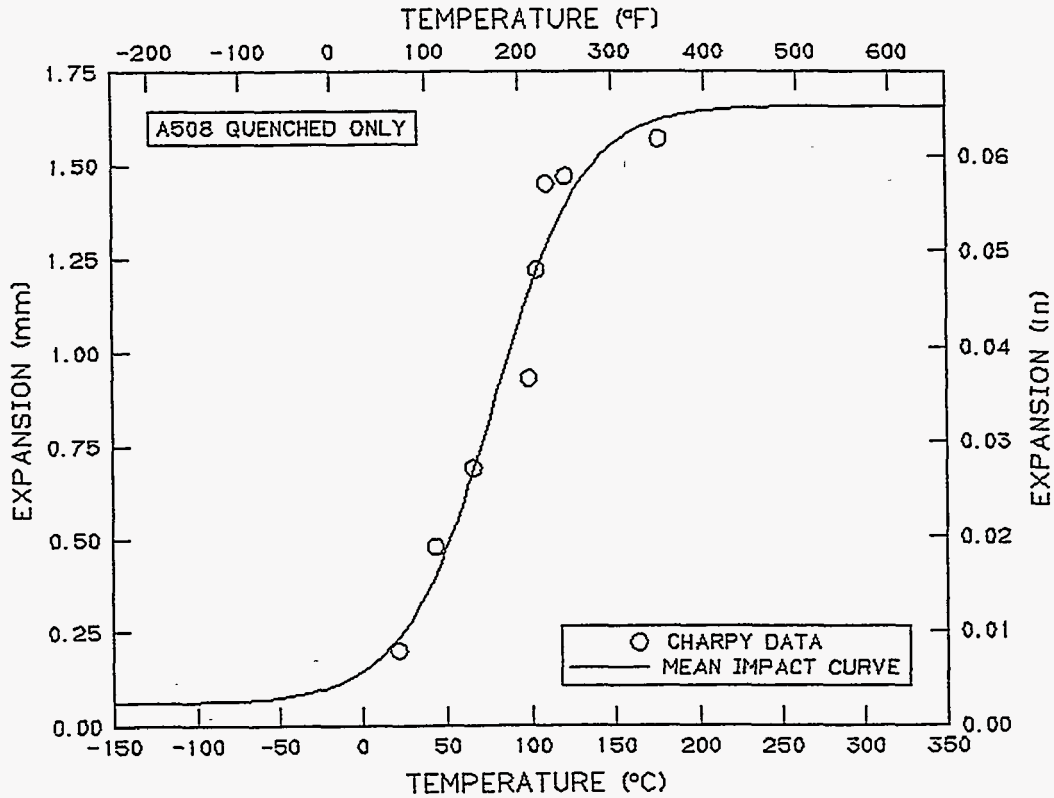

NOTE: A508, QUENCHED ONLY, FULL-SIZE
MODEL SET NAME: 508_QUEN.FE

DATA SOURCE: ANALYSIS SET

ANALYSIS SET: 508_QUEN.F

Y VARIABLE: SHEAR

MODEL PARAMETERS

LOWER SHELF SHEAR [HELD FIXED]: 0 (PERCENT)

MID-TRANSITION TEMPERATURE: 78.3 (DEG C), 173 (DEG F)

TRANSITION ZONE WIDTH: 62.6 (C DEG), 112.6 (F DEG)

UPPER SHELF SHEAR [HELD FIXED]: 100 (PERCENT)

UPPER SHELF SHEAR: 100 (PERCENT)

TEMPERATURE [50 (PERCENT), 50 (PERCENT) SHEAR]: 78.3 (DEG C), 173 (DEG F)

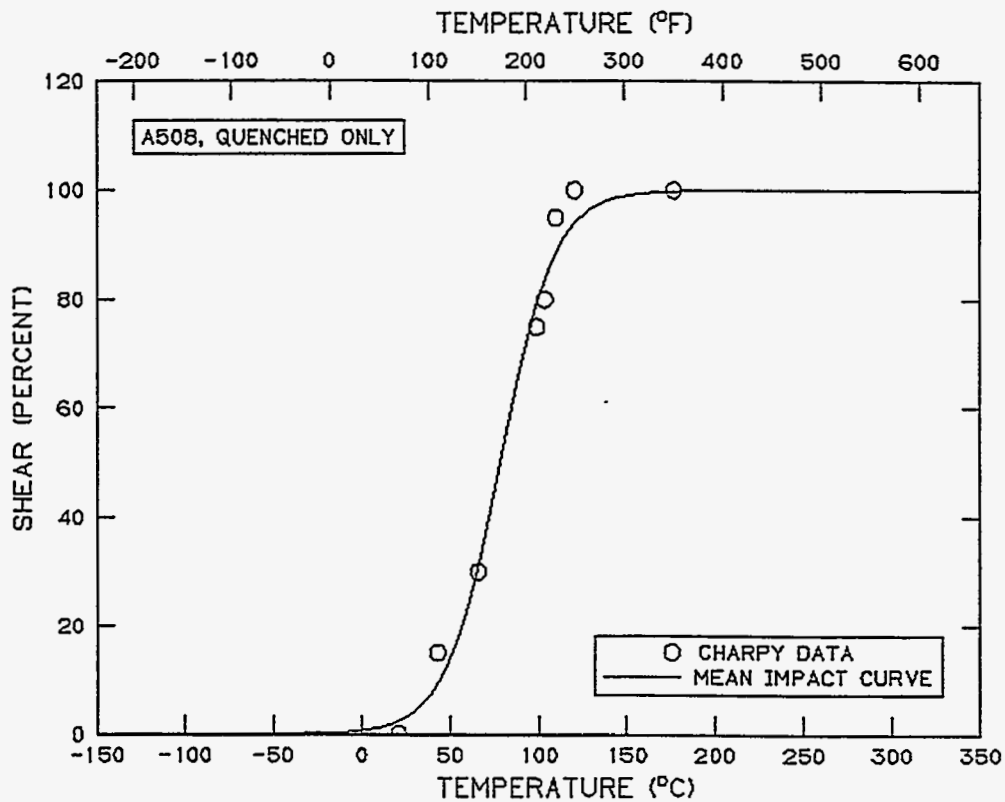

REMARK: A508, QUENCHED ONLY, FULL-SIZE
MODEL SET NAME: 508_QUEN.FS

SOURCE: ANALYSIS SET
ANALYSIS SET NAME: A508QUEN.T1

SET NAME: A508QUEN.T1
NOTE: A508 QUENCHED ONLY, TYPE 1

IDENT	TEMPERATURE		ENERGY (J)	(FT-LB)	EXPANSION		SHEAR (PERCENT)
	(DEG C)	(DEG F)			(MM)	(IN)	
761D	-75.0	-103.0	1.50	1.11	0.00	0.000	0.0
761C	-50.0	-58.0	7.33	5.41	0.18	0.007	5.0
766A	-25.0	-13.0	1.38	1.02	0.00	0.000	0.0
766B	-12.5	9.5	2.03	1.50	0.00	0.000	0.0
761B	0.0	32.0	15.27	11.26	0.41	0.016	20.0
718D	0.0	32.0	5.50	4.06	0.15	0.006	0.0
766D	12.5	54.5	3.32	2.45	0.03	0.001	5.0
766C	25.0	77.0	8.60	6.34	0.13	0.005	5.0
756A	37.5	99.5	15.68	11.57	0.56	0.022	50.0
756B	50.0	122.0	14.20	10.47	0.41	0.016	45.0
756C	62.5	144.5	13.96	10.30	0.41	0.016	40.0
718A	75.0	167.0	18.82	13.88	0.66	0.026	80.0
756D	100.0	212.0	19.51	14.39	0.69	0.027	100.0
718C	150.0	302.0	21.83	16.10	0.89	0.035	100.0
761A	200.0	392.0	20.99	15.48	0.89	0.035	100.0
761A	200.0	392.0	20.98	15.48	0.89	0.035	100.0
718B	250.0	482.0	21.10	15.56	0.79	0.031	100.0

NUMBER OF SPECIMENS: 17

SOURCE: A508QUEN.T1 ANALYSIS SET

Y VARIABLE: ENERGY

MODEL PARAMETERS

LOWER SHELF ENERGY [HELD FIXED]: 0.1 (J), 0.1 (FT-LB)

MID-TRANSITION TEMPERATURE: 27.4 (DEG C), 81.4 (DEG F)

TRANSITION ZONE WIDTH: 141.4 (C DEG), 254.6 (F DEG)

UPPER SHELF ENERGY: 21.6 (J), 15.9 (FT-LB)

UPPER SHELF ENERGY: 21.6 (J), 15.9 (FT-LB)

NOTE: A508, QUENCHED ONLY, TYPE 1

MODEL SET NAME: 2

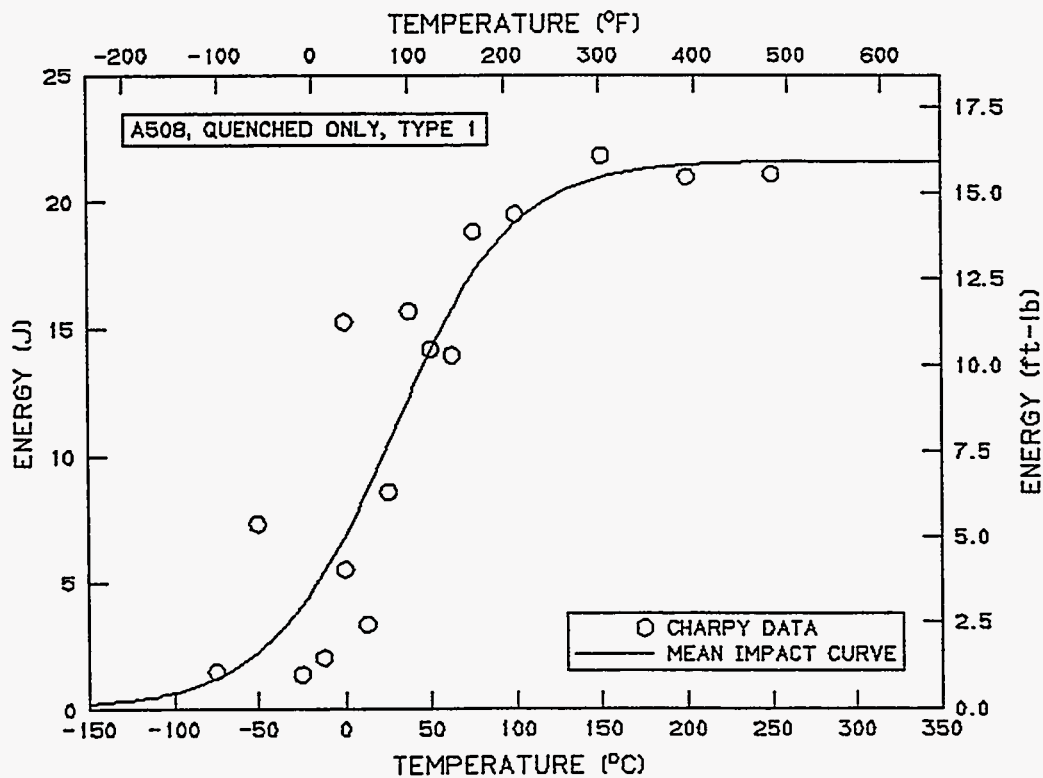

SOURCE: A508QUEN.T1 ANALYSIS SET

Y VARIABLE: EXPANSION

MODEL PARAMETERS

LOWER SHELF EXPANSION [HELD FIXED]: 0.000 (MM), 0.0000 (IN)

MID-TRANSITION TEMPERATURE: 51.3 (DEG C), 124.3 (DEG F)

TRANSITION ZONE WIDTH: 126.8 (C DEG), 228.2 (F DEG)

UPPER SHELF EXPANSION: 0.872 (MM), 0.0343 (IN)

UPPER SHELF EXPANSION: 0.872 (MM), 0.0343 (IN)

NOTE: A508, QUENCHED ONLY, TYPE 1

MODEL SET NAME: 3

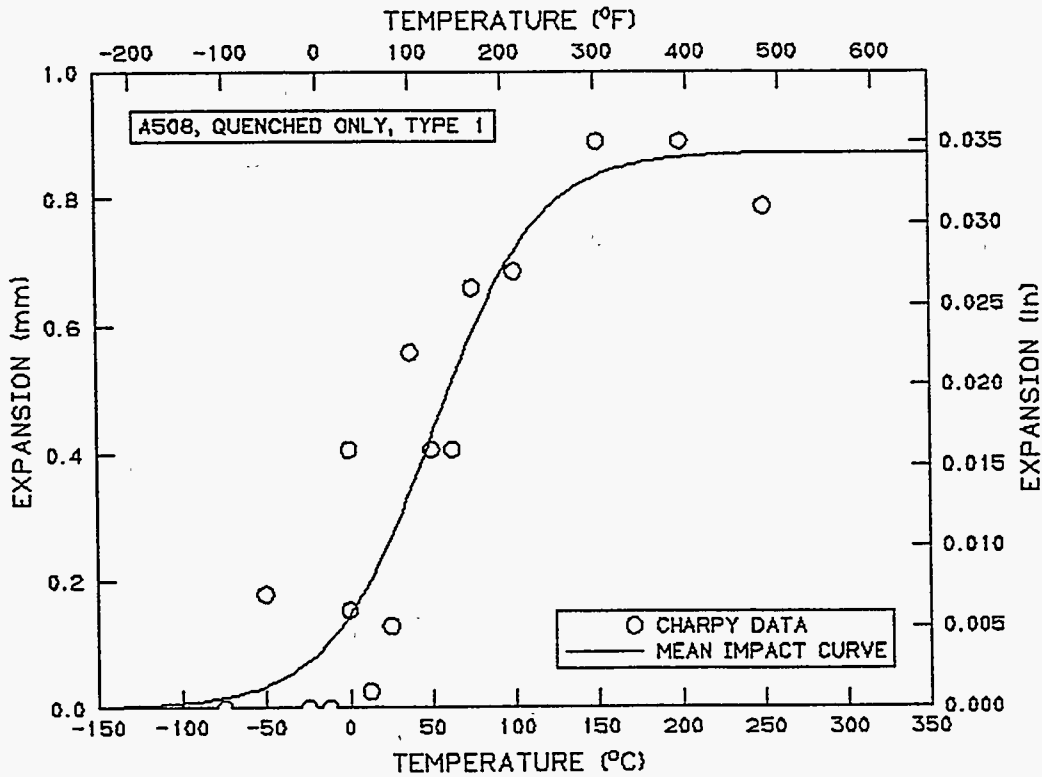

SOURCE: A508QUEN.T1 ANALYSIS SET

Y VARIABLE: SHEAR

MODEL PARAMETERS

LOWER SHELF SHEAR [HELD FIXED]: 0 (PERCENT)

MID-TRANSITION TEMPERATURE: 55.0 (DEG C), 131.0 (DEG F)

TRANSITION ZONE WIDTH: 77.7 (C DEG), 139.9 (F DEG)

UPPER SHELF SHEAR [HELD FIXED]: 100 (PERCENT)

UPPER SHELF SHEAR: 100 (PERCENT)

TEMPERATURE [50 (PERCENT), 50 (PERCENT) SHEAR]: 55.0 (DEG C), 131.0 (DEG F)

NOTE: A508, QUENCHED ONLY, TYPE 1

MODEL SET NAME: 4

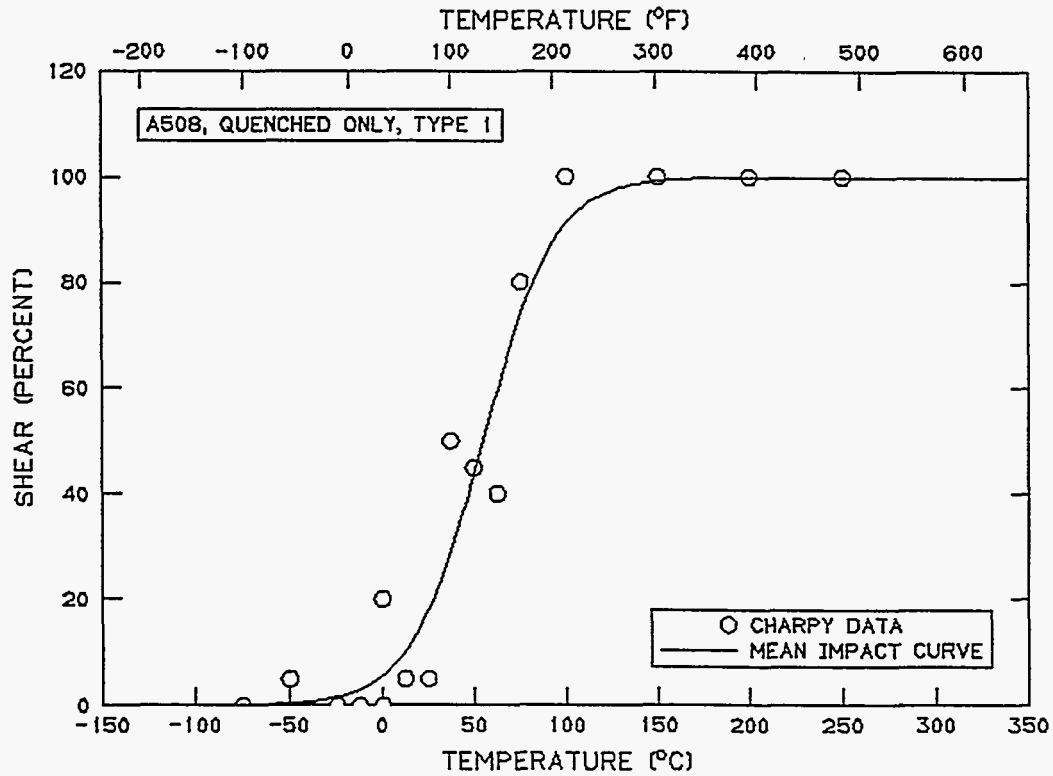

SOURCE: ANALYSIS SET
ANALYSIS SET NAME: A508QUEN.T2

SET NAME: A508QUEN.T2
NOTE: A508, QUENCHED ONLY (TYPE 2 SPECIMEN)

IDENT	TEMPERATURE		ENERGY		EXPANSION		SHEAR (PERCENT)
	(DEG C)	(DEG F)	(J)	(FT-LB)	(MM)	(IN)	
762A	-75.0	-103.0	0.92	0.68	0.00	0.000	0.0
762B	-62.5	-80.5	0.46	0.34	0.00	0.000	0.0
747D	-50.0	-58.0	1.83	1.35	UNKNOWN		0.0
762C	-37.5	-35.5	0.72	0.53	0.00	0.000	0.0
747C	-25.0	-13.0	3.46	2.55	0.15	0.006	5.0
762D	-12.5	9.5	3.06	2.26	0.10	0.004	10.0
747B	0.0	32.0	4.42	3.26	0.18	0.007	10.0
7711A	12.5	54.5	3.71	2.74	0.20	0.008	15.0
747A	25.0	77.0	5.69	4.20	0.30	0.012	80.0
7711B	37.5	99.5	6.28	4.63	0.41	0.016	100.0
7711C	50.0	122.0	5.76	4.25	0.33	0.013	75.0
774A	100.0	212.0	5.76	4.25	0.38	0.015	100.0
7711D	200.0	392.0	5.95	4.39	0.33	0.013	100.0

NUMBER OF SPECIMENS: 13

SOURCE: A508QUEN.T2 ANALYSIS SET

Y VARIABLE: ENERGY

MODEL PARAMETERS

LOWER SHELF ENERGY [HELD FIXED]: 0.1 (J), 0.1 (FT-LB)

MID-TRANSITION TEMPERATURE: -16.7 (DEG C), 2.0 (DEG F)

TRANSITION ZONE WIDTH: 90.4 (C DEG), 162.7 (F DEG)

UPPER SHELF ENERGY: 6.1 (J), 4.5 (FT-LB)

UPPER SHELF ENERGY: 6.1 (J), 4.5 (FT-LB)

NOTE: A508, QUENCHED ONLY, TYPE 2

MODEL SET NAME: 7

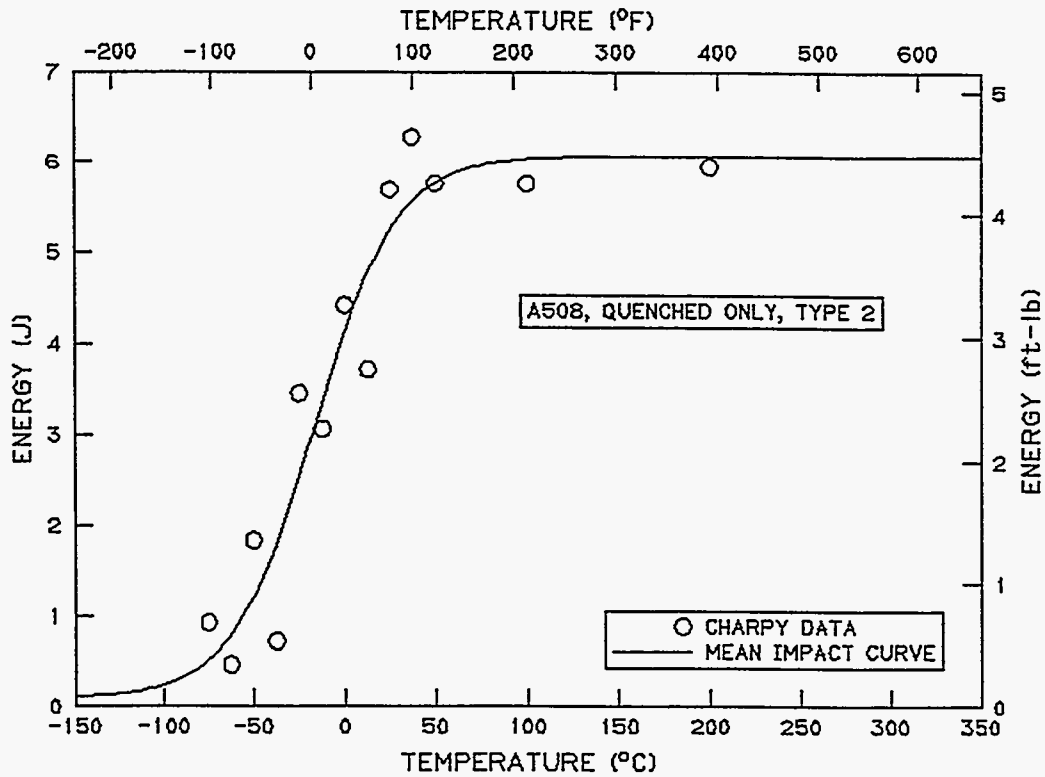

SOURCE: A508QUEN.T2 ANALYSIS SET

Y VARIABLE: EXPANSION

MODEL PARAMETERS

LOWER SHELF EXPANSION [HELD FIXED]: 0.000 (MM), 0.0000 (IN)

MID-TRANSITION TEMPERATURE: 0.0 (DEG C), 32.0 (DEG F)

TRANSITION ZONE WIDTH: 69.1 (C DEG), 124.4 (F DEG)

UPPER SHELF EXPANSION: 0.369 (MM), 0.0145 (IN)

UPPER SHELF EXPANSION: 0.369 (MM), 0.0145 (IN)

NOTE: A508, QUENCHED ONLY, TYPE 2

MODEL SET NAME: 6

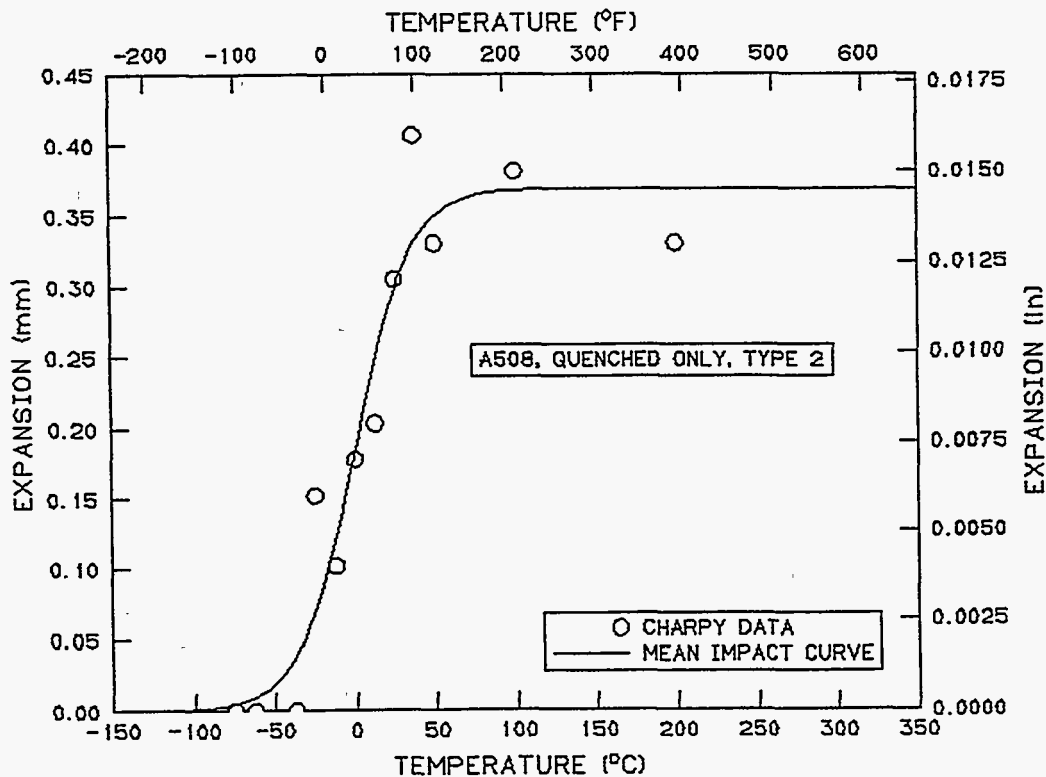

SOURCE: A508QUEN.T2 ANALYSIS SET

Y VARIABLE: SHEAR

MODEL PARAMETERS

LOWER SHELF SHEAR [HELD FIXED]: 0 (PERCENT)

MID-TRANSITION TEMPERATURE: 19.3 (DEG C), 66.8 (DEG F)

TRANSITION ZONE WIDTH: 16.9 (C DEG), 30.4 (F DEG)

UPPER SHELF SHEAR [HELD FIXED]: 100 (PERCENT)

UPPER SHELF SHEAR: 100 (PERCENT)

TEMPERATURE [50 (PERCENT), 50 (PERCENT) SHEAR]: 19.3 (DEG C), 66.8 (DEG F)

NOTE: A508 QUENCHED ONLY, TYPE 2

MODEL SET NAME: 5

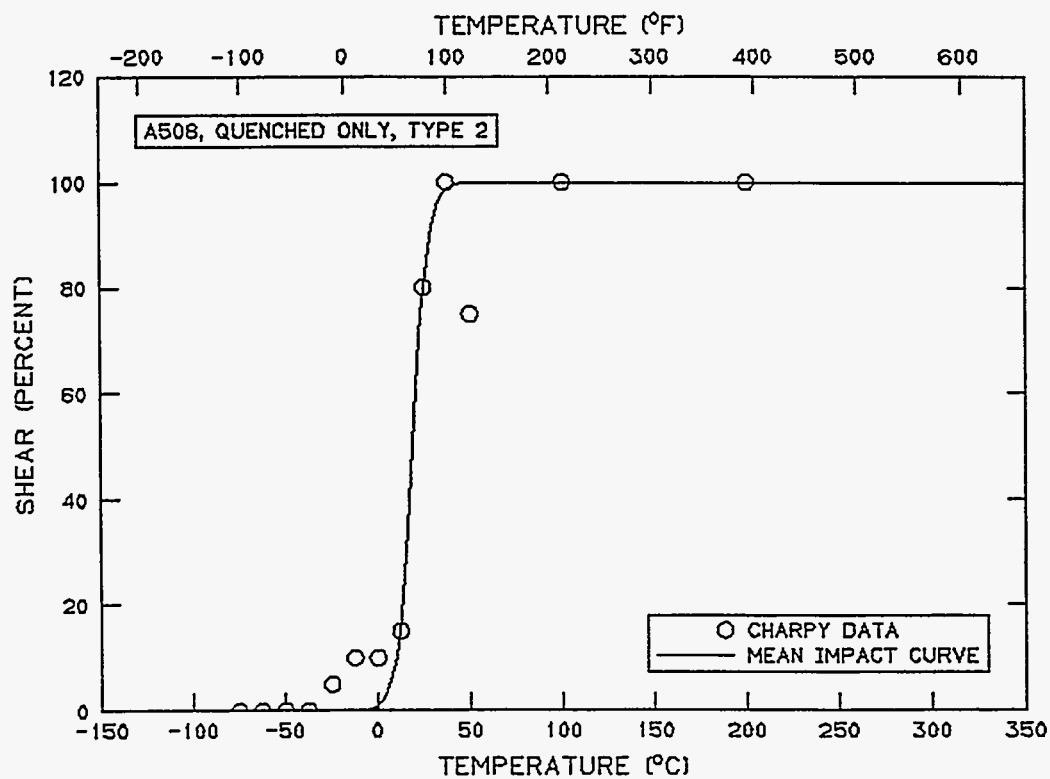

SOURCE: ANALYSIS SET
 ANALYSIS SET NAME: A508QUEN.T3

SET NAME: A508QUEN.T3
 NOTE: A508 QUENCHED, SPECIMEN TYPE 3

IDENT	TEMPERATURE		ENERGY (J)	(FT-LB)	EXPANSION		SHEAR (PERCENT)
	(DEG C)	(DEG F)			(MM)	(IN)	
711D	-100.0	-148.0	1.08	0.80	0.00	0.000	0.0
711C	-75.0	-103.0	2.30	1.70	0.00	0.000	0.0
711B	-50.0	-58.0	2.58	1.90	0.00	0.000	0.0
711A	-37.5	-35.5	3.66	2.70	0.03	0.001	0.0
77D	-25.0	-13.0	3.39	2.50	0.00	0.000	0.0
77C	-12.5	9.5	3.66	2.70	0.03	0.001	5.0
77B	0.0	32.0	8.00	5.90	0.23	0.009	15.0
77A	12.5	54.5	7.59	5.60	0.25	0.010	25.0
719B	37.5	99.5	10.17	7.50	0.43	0.017	60.0
717A	50.0	122.0	9.63	7.10	0.33	0.013	45.0
719A	75.0	167.0	10.85	8.00	0.46	0.018	50.0
717B	100.0	212.0	15.32	11.30	0.64	0.025	100.0
719C	100.0	212.0	14.24	10.50	0.71	0.028	100.0
717D	150.0	302.0	17.49	12.90	0.74	0.029	100.0
719D	150.0	302.0	14.91	11.00	0.56	0.022	100.0
717C	200.0	392.0	16.95	12.50	0.74	0.029	100.0

NUMBER OF SPECIMENS: 16

SOURCE: A508QUEN.T3 ANALYSIS SET

Y VARIABLE: ENERGY

MODEL PARAMETERS

LOWER SHELF ENERGY [HELD FIXED]: 0.1 (J), 0.1 (FT-LB)

MID-TRANSITION TEMPERATURE: 32.2 (DEG C), 90.0 (DEG F)

TRANSITION ZONE WIDTH: 195.1 (C DEG), 351.3 (F DEG)

UPPER SHELF ENERGY: 17.6 (J), 13.0 (FT-LB)

UPPER SHELF ENERGY: 17.6 (J), 13.0 (FT-LB)

NOTE: A508, QUENCHED ONLY, TYPE 3

MODEL SET NAME: 8

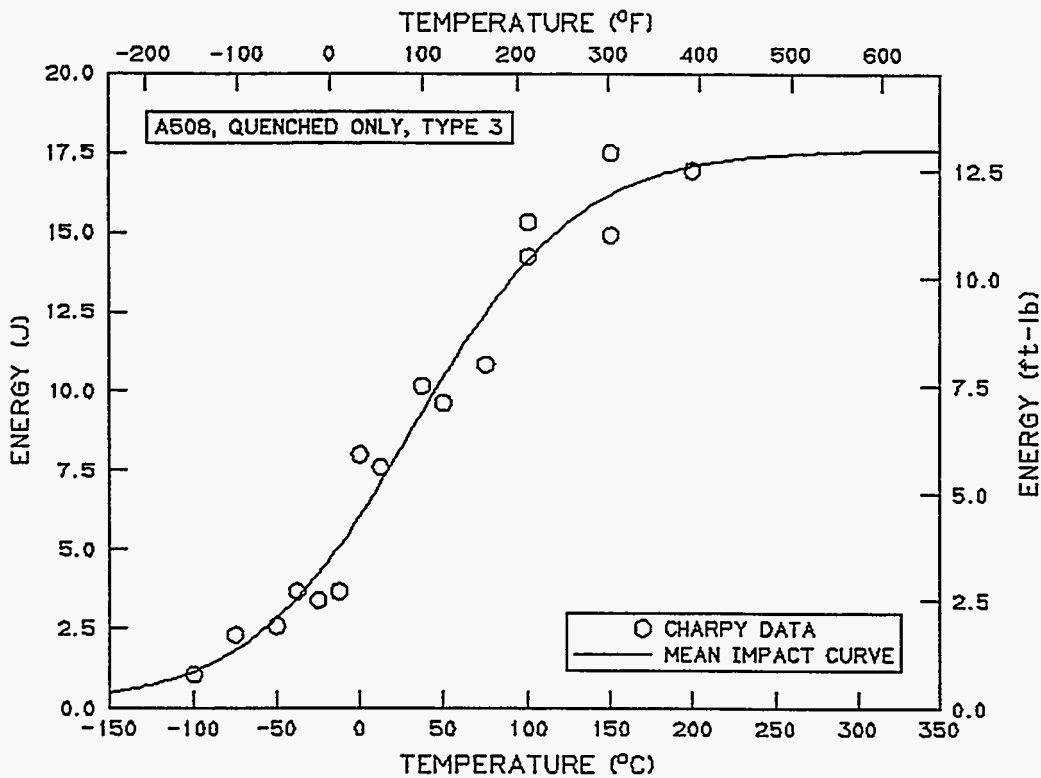

SOURCE: A508QUEN.T3 ANALYSIS SET

Y VARIABLE: EXPANSION

MODEL PARAMETERS

LOWER SHELF EXPANSION [HELD FIXED]: 0.000 (MM), 0.0000 (IN)

MID-TRANSITION TEMPERATURE: 38.3 (DEG C), 101.0 (DEG F)

TRANSITION ZONE WIDTH: 115.5 (C DEG), 208.0 (F DEG)

UPPER SHELF EXPANSION: 0.696 (MM), 0.0274 (IN)

UPPER SHELF EXPANSION: 0.696 (MM), 0.0274 (IN)

NOTE: A508, QUENCHED ONLY, TYPE 3

MODEL SET NAME: 9

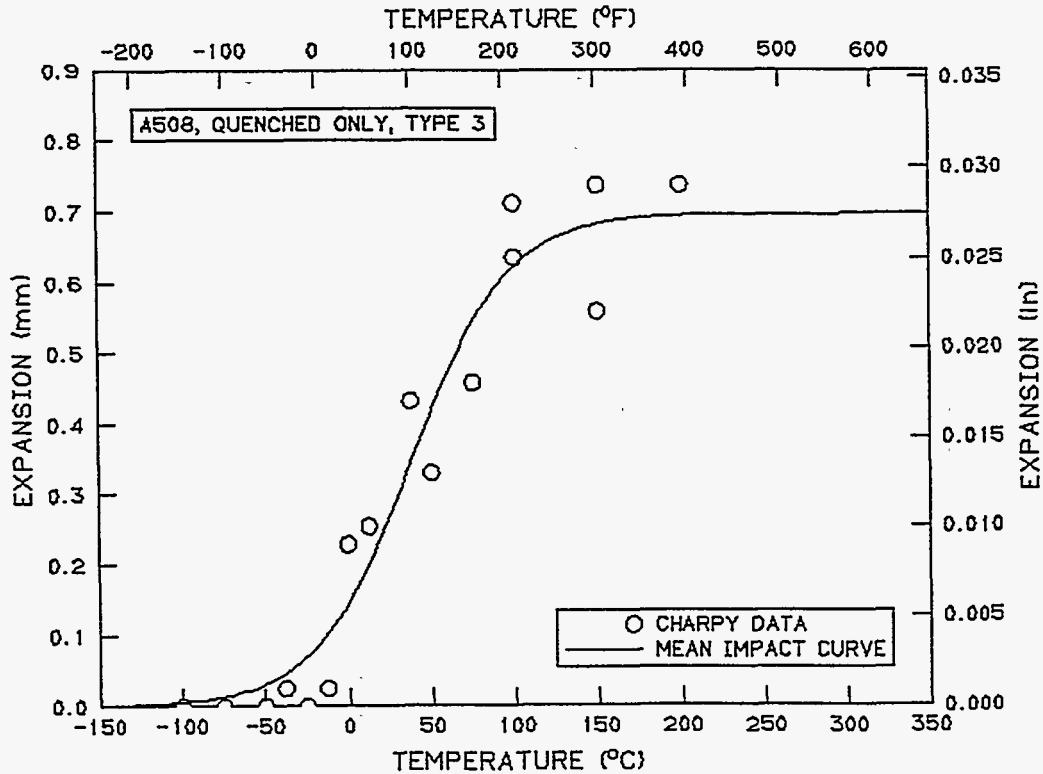

SOURCE: A508QUEN.T3 ANALYSIS SET

Y VARIABLE: SHEAR

MODEL PARAMETERS

LOWER SHELF SHEAR [HELD FIXED]: 0 (PERCENT)

MID-TRANSITION TEMPERATURE: 46.7 (DEG C), 116.0 (DEG F)

TRANSITION ZONE WIDTH: 105.2 (C DEG), 189.4 (F DEG)

UPPER SHELF SHEAR [HELD FIXED]: 100 (PERCENT)

UPPER SHELF SHEAR: 100 (PERCENT)

TEMPERATURE [50 (PERCENT), 50 (PERCENT) SHEAR]: 46.7 (DEG C), 116.0 (DEG F)

NOTE: A508, QUENCHED ONLY, TYPE 3

MODEL SET NAME: 0

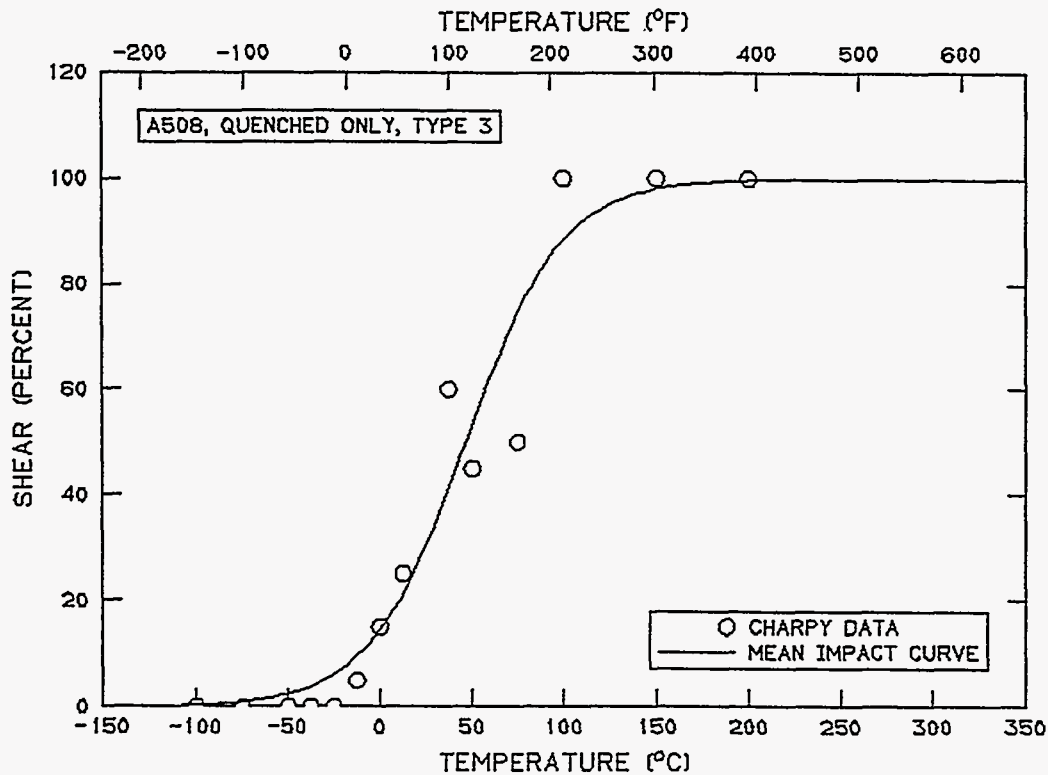

SOURCE: ANALYSIS SET
ANALYSIS SET NAME: A508QUEN.T4

SET NAME: A508QUEN.T4
NOTE: A508 QUENCHED, TYPE 4

IDENT	TEMPERATURE		ENERGY (J)	EXPANSION			SHEAR (PERCENT)
	(DEG C)	(DEG F)		(FT-LB)	(MM)	(IN)	
757F	-50.0	-58.0	1.91	1.41	0.03	0.001	0.0
776E	-50.0	-58.0	0.27	0.20	0.00	0.000	0.0
757E	-37.5	-35.5	1.19	0.88	0.13	0.005	0.0
757D	-25.0	-13.0	0.53	0.39	0.00	0.000	0.0
757C	-12.5	9.5	0.53	0.39	0.00	0.000	0.0
776D	-12.5	9.5	1.59	1.17	0.00	0.000	0.0
757B	0.0	32.0	2.70	1.99	0.18	0.007	20.0
776C	12.5	54.5	2.97	2.19	0.23	0.009	30.0
757A	25.0	77.0	3.35	2.47	0.20	0.008	50.0
776B	25.0	77.0	3.16	2.33	0.23	0.009	30.0
767A	37.5	99.5	2.30	1.70	0.15	0.006	20.0
776A	37.5	99.5	3.16	2.33	0.23	0.009	40.0
767B	50.0	122.0	2.96	2.18	0.25	0.010	40.0
767F	75.0	167.0	4.70	3.47	0.41	0.016	80.0
767C	100.0	212.0	5.29	3.90	0.46	0.018	100.0
767E	150.0	302.0	5.10	3.76	0.48	0.019	100.0
767D	200.0	392.0	5.22	3.85	0.48	0.019	100.0
776F	250.0	482.0	5.63	4.15	0.43	0.017	100.0

NUMBER OF SPECIMENS: 18

SOURCE: A508QUEN.T4 ANALYSIS SET

Y VARIABLE: ENERGY

MODEL PARAMETERS

LOWER SHELF ENERGY [HELD FIXED]: 0.1 (J), 0.1 (FT-LB)

MID-TRANSITION TEMPERATURE: 24.9 (DEG C), 76.8 (DEG F)

TRANSITION ZONE WIDTH: 154.6 (C DEG), 278.3 (F DEG)

UPPER SHELF ENERGY: 5.5 (J), 4.1 (FT-LB)

UPPER SHELF ENERGY: 5.5 (J), 4.1 (FT-LB)

NOTE: A508, QUENCHED ONLY, TYPE 4

MODEL SET NAME: 3

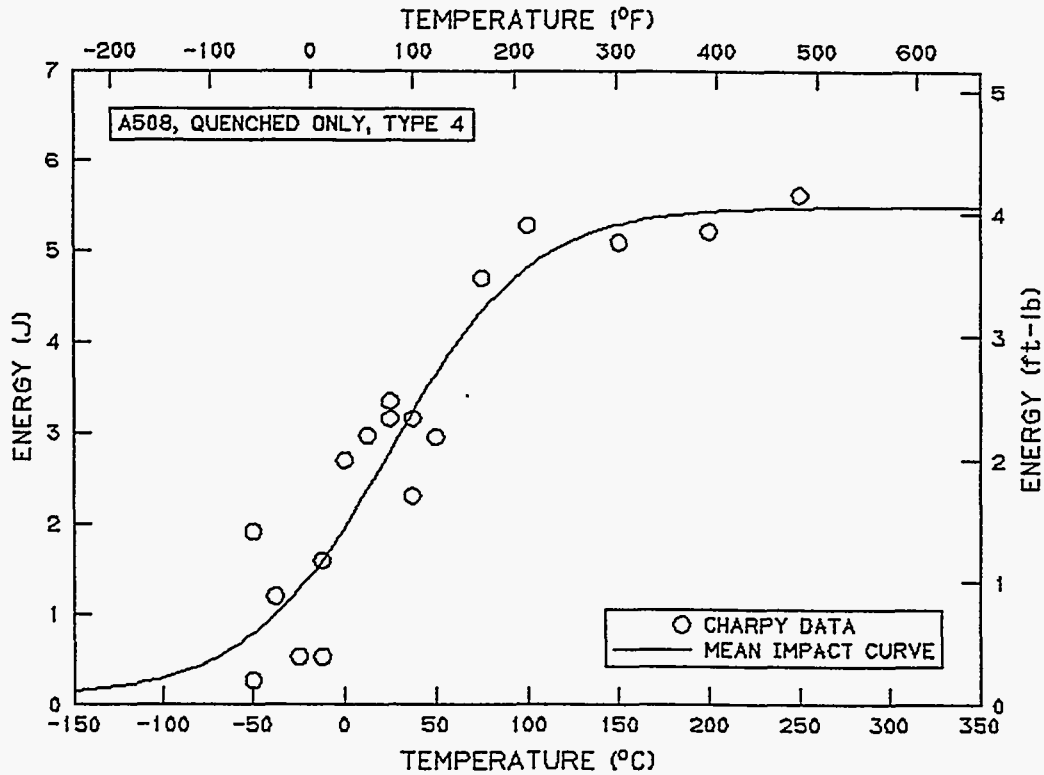

SOURCE: A508QUEN.T4 ANALYSIS SET

Y VARIABLE: EXPANSION

MODEL PARAMETERS

LOWER SHELF EXPANSION [HELD FIXED]: 0.000 (MM), 0.0000 (IN)

MID-TRANSITION TEMPERATURE: 36.9 (DEG C), 98.3 (DEG F)

TRANSITION ZONE WIDTH: 114.4 (C DEG), 205.9 (F DEG)

UPPER SHELF EXPANSION: 0.475 (MM), 0.0187 (IN)

UPPER SHELF EXPANSION: 0.475 (MM), 0.0187 (IN)

NOTE: A508, QUENCHED ONLY, TYPE 4

MODEL SET NAME: 2

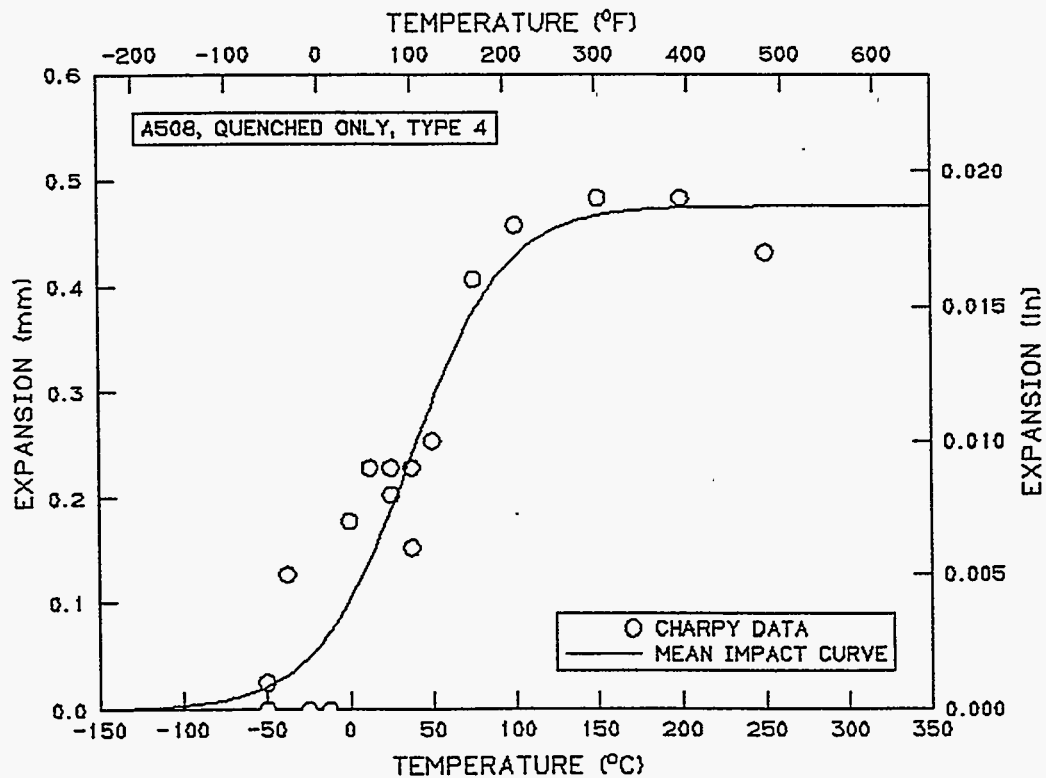

SOURCE: A508QUEN.T4 ANALYSIS SET

Y VARIABLE: SHEAR

MODEL PARAMETERS

LOWER SHELF SHEAR [HELD FIXED]: 0 (PERCENT)

MID-TRANSITION TEMPERATURE: 47.7 (DEG C), 117.9 (DEG F)

TRANSITION ZONE WIDTH: 96.9 (C DEG), 174.3 (F DEG)

UPPER SHELF SHEAR [HELD FIXED]: 100 (PERCENT)

UPPER SHELF SHEAR: 100 (PERCENT)

TEMPERATURE [50 (PERCENT), 50 (PERCENT) SHEAR]: 47.7 (DEG C), 117.9 (DEG F)

NOTE: A508, QUENCHED ONLY, TYPE 4

MODEL SET NAME: 1

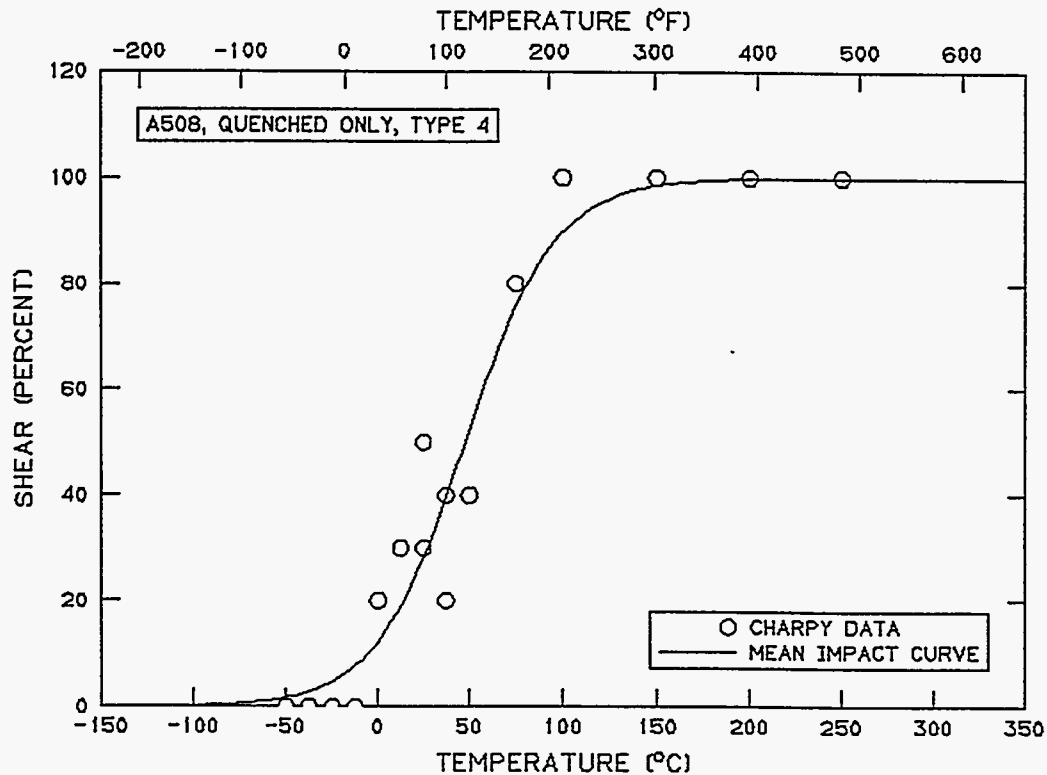

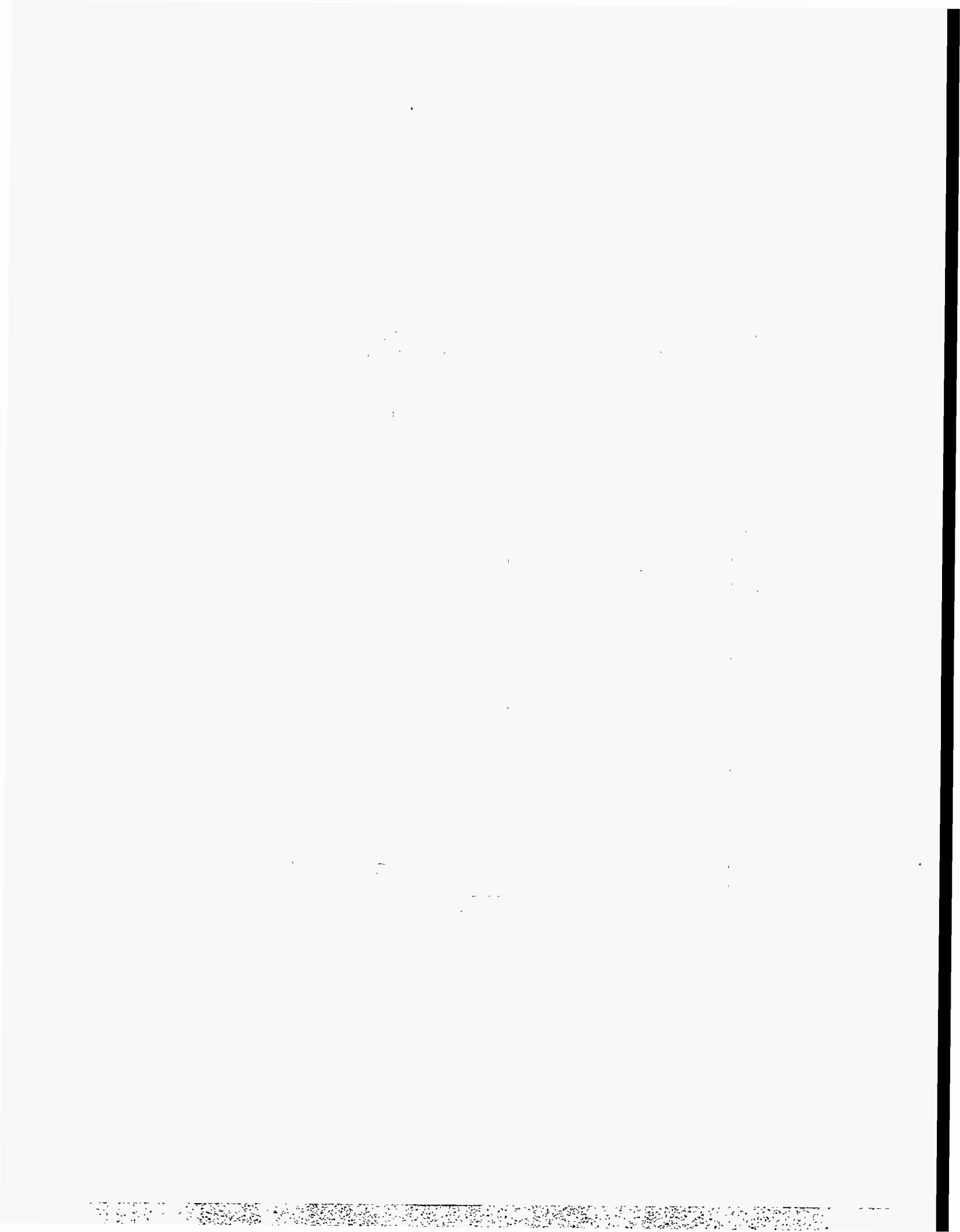

APPENDIX D

A 508, QUENCHED AND TEMPERED AT 599°C

SOURCE: ANALYSIS SET
ANALYSIS SET NAME: 508_1100.F

SET NAME: 508_1100.F

NOTE: A508, QUENCHED & TEMPERED @ 1100 F

IDENT	TEMPERATURE		ENERGY		EXPANSION		SHEAR (PERCENT)
	(DEG C)	(DEG F)	(J)	(FT-LB)	(MM)	(IN)	
3SC-20	-18.0	-0.4	10.00	7.38	0.13	0.005	0.0
3SC-8	21.0	69.8	39.00	28.76	0.30	0.012	0.0
3SC-10	66.0	150.8	51.00	37.62	0.69	0.027	30.0
3SC-14	104.0	219.2	65.00	47.94	1.09	0.043	65.0
3SC-22	110.0	230.0	99.00	73.02	1.42	0.056	100.0
3SC-12	121.0	249.8	75.00	55.32	1.17	0.046	85.0
3SC-16	149.0	300.2	96.00	70.81	1.47	0.058	100.0
3SC-18	204.0	399.2	97.00	71.54	1.52	0.060	100.0

NUMBER OF SPECIMENS: 8

ANALYSIS SET: 508_1100.F

Y VARIABLE: ENERGY

MODEL PARAMETERS

LOWER SHELF ENERGY [HELD FIXED]: 2.7 (J), 2.0 (FT-LB)

MID-TRANSITION TEMPERATURE: 59.6 (DEG C), 139.2 (DEG F)

TRANSITION ZONE WIDTH: 164.8 (C DEG), 296.6 (F DEG)

UPPER SHELF ENERGY: 101.9 (J), 75.2 (FT-LB)

UPPER SHELF ENERGY: 101.9 (J), 75.2 (FT-LB)

TEMPERATURE [41 (J), 30.2 (FT-LB) ENERGY]: 40.5 (DEG C), 104.8 (DEG F)

TEMPERATURE [68 (J), 50.2 (FT-LB) ENERGY]: 86.6 (DEG C), 187.8 (DEG F)

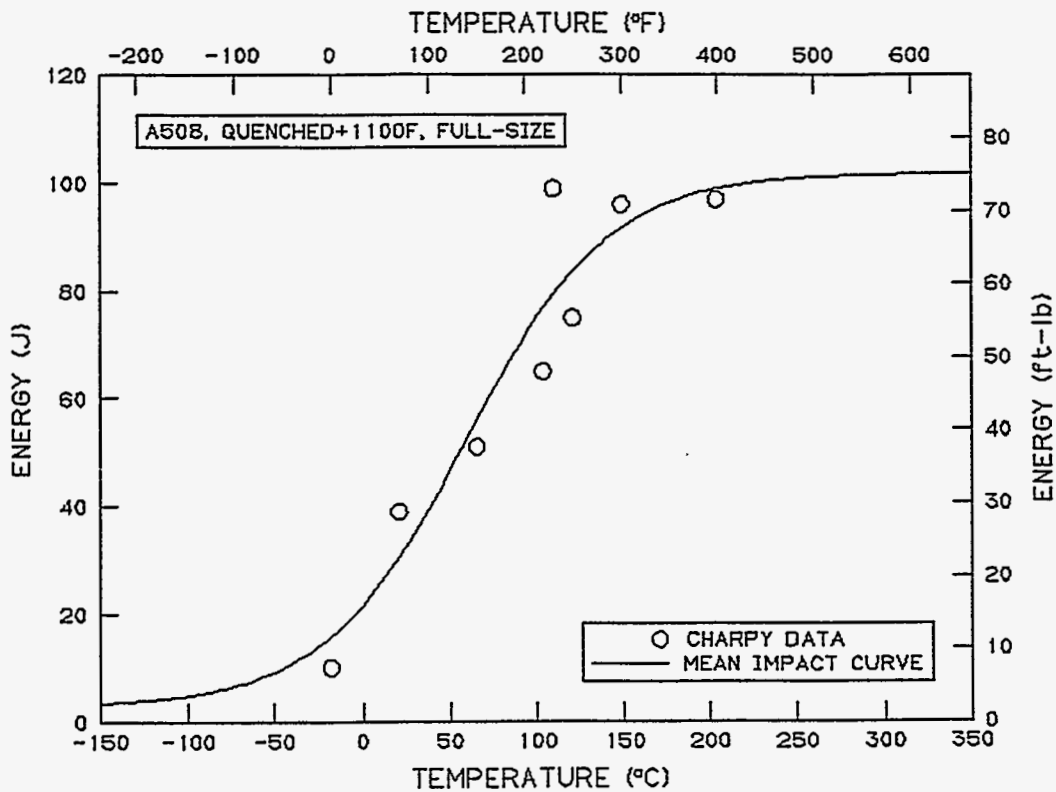

NOTE: A508, QUENCHED & TEMPERED @ 1100 F, FULL-SIZE
MODEL SET NAME: 508_1100.F

ANALYSIS SET: 508_1100.F

Y VARIABLE: EXPANSION

MODEL PARAMETERS

LOWER SHELF EXPANSION [HELD FIXED]: 0.061 (MM),0.0024 (IN)

MID-TRANSITION TEMPERATURE: 72.8 (DEG C),163.0 (DEG F)

TRANSITION ZONE WIDTH: 117.8 (C DEG),212.1 (F DEG)

UPPER SHELF EXPANSION: 1.545 (MM),0.0608 (IN)

UPPER SHELF EXPANSION: 1.545 (MM),0.0608 (IN)

TEMPERATURE [0.89 (MM),0.035 (IN) EXPANSION]: 79.7 (DEG C),175.5 (DEG F)

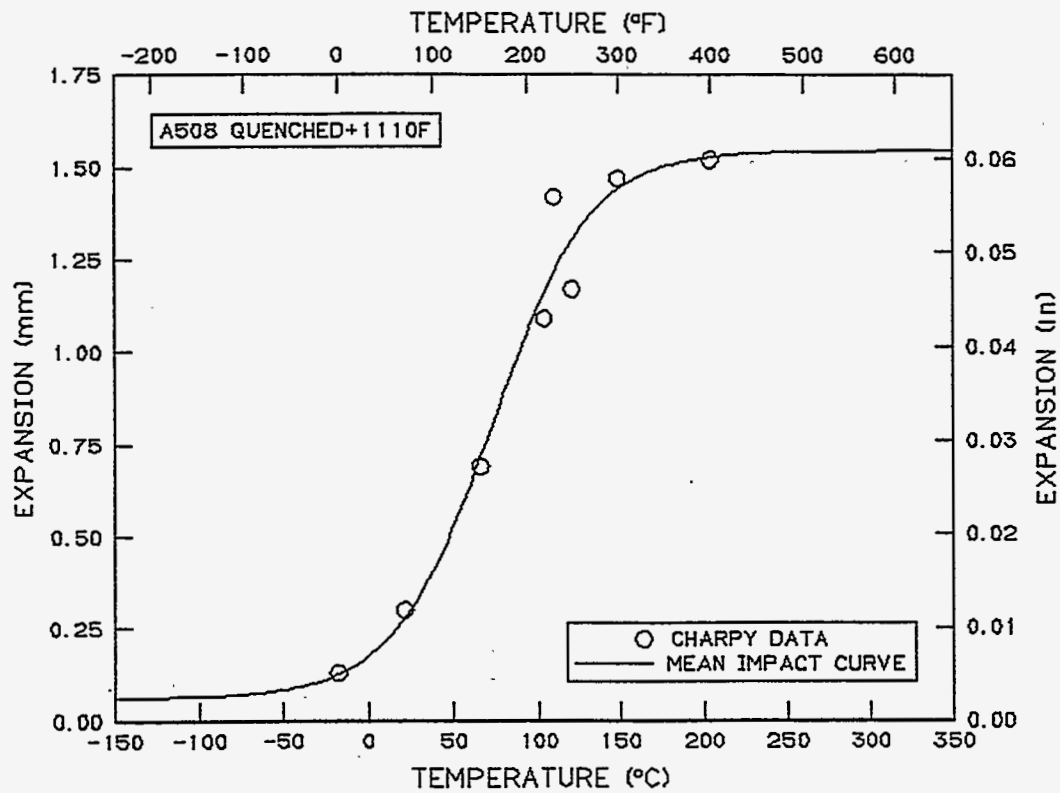

NOTE: A508, QUENCHED+1100F, FULL-SIZE
MODEL SET NAME: 508_1100.FE

DATA SOURCE: ANALYSIS SET

ANALYSIS SET: 508_1100.F

Y VARIABLE: SHEAR

MODEL PARAMETERS

LOWER SHELF SHEAR [HELD FIXED]: 0 (PERCENT)

MID-TRANSITION TEMPERATURE: 82.3 (DEG C), 180.1 (DEG F)

TRANSITION ZONE WIDTH: 69.2 (C DEG), 124.6 (F DEG)

UPPER SHELF SHEAR [HELD FIXED]: 100 (PERCENT)

UPPER SHELF SHEAR: 100 (PERCENT)

TEMPERATURE [50 (PERCENT), 50 (PERCENT) SHEAR]: 82.3 (DEG C), 180.1 (DEG F)

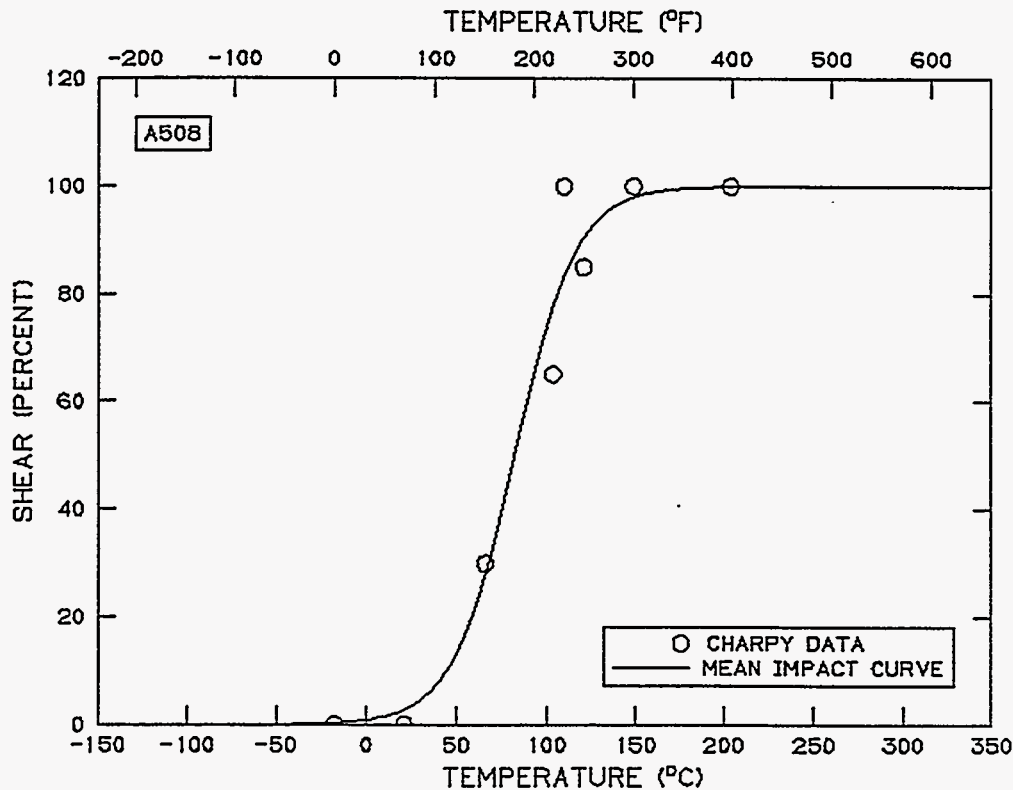

REMARK: A508, QUENCHED & TEMPERED @ 1100 F

MODEL SET NAME: 508_1100.FS

SOURCE: ANALYSIS SET
ANALYSIS SET NAME: A5081100.T1

SET NAME: A5081100.T1
NOTE: A508 QUENCHED+1100F, TYPE 1

IDENT	TEMPERATURE		ENERGY (J)	EXPANSION		SHEAR (PERCENT)	
	(DEG C)	(DEG F)		(FT-LB)	(MM) (IN)		
338A	-75.0	-103.0	0.85	0.63	0.00	0.000	0.0
338B	-62.5	-80.5	3.35	2.47	0.00	0.000	0.0
321D	-50.0	-58.0	3.61	2.66	0.03	0.001	0.0
338C	-37.5	-35.5	7.00	5.16	0.13	0.005	0.0
321C	-25.0	-13.0	11.31	8.34	0.30	0.012	5.0
339D	-25.0	-13.0	4.83	3.56	0.13	0.005	0.0
338D	-12.5	9.5	11.19	8.25	0.41	0.016	10.0
321B	0.0	32.0	10.07	7.43	0.23	0.009	5.0
339A	12.5	54.5	8.51	6.28	0.20	0.008	15.0
319A	25.0	77.0	11.73	8.65	0.33	0.013	10.0
319B	50.0	122.0	14.44	10.65	0.43	0.017	45.0
339B	75.0	167.0	20.20	14.90	0.66	0.026	80.0
319C	100.0	212.0	21.44	15.81	0.74	0.029	100.0
319D	125.0	257.0	20.70	15.27	0.76	0.030	100.0
339C	200.0	392.0	21.68	15.99	0.89	0.035	100.0
321A	250.0	482.0	18.25	13.46	0.74	0.029	100.0

NUMBER OF SPECIMENS: 16

SOURCE: A5081100.T1 ANALYSIS SET

Y VARIABLE: ENERGY

MODEL PARAMETERS

LOWER SHELF ENERGY [HELD FIXED]: 0.1 (J), 0.1 (FT-LB)

MID-TRANSITION TEMPERATURE: 3.7 (DEG C), 38.7 (DEG F)

TRANSITION ZONE WIDTH: 161.3 (C DEG), 290.3 (F DEG)

UPPER SHELF ENERGY: 21.1 (J), 15.6 (FT-LB)

UPPER SHELF ENERGY: 21.1 (J), 15.6 (FT-LB)

NOTE: NONE

MODEL SET NAME: 8

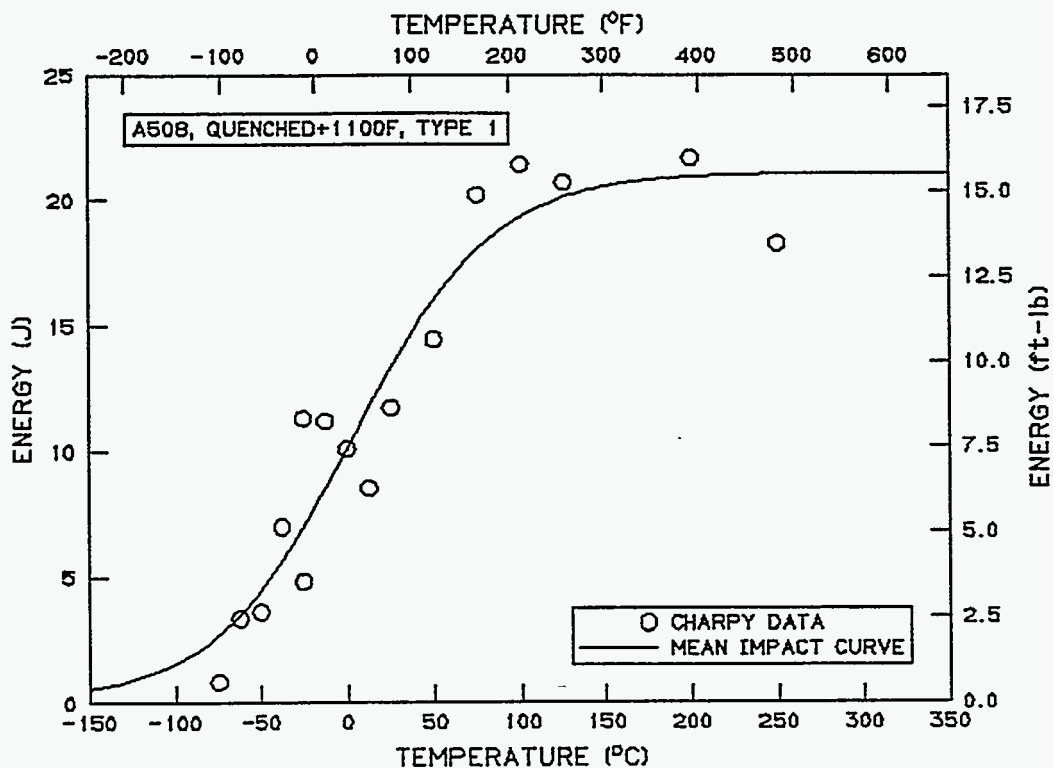

SOURCE: A5081100.T1 ANALYSIS SET

Y VARIABLE: EXPANSION

MODEL PARAMETERS

LOWER SHELF EXPANSION [HELD FIXED]: 0.000 (MM), 0.0000 (IN)

MID-TRANSITION TEMPERATURE: 33.6 (DEG C), 92.6 (DEG F)

TRANSITION ZONE WIDTH: 161.5 (C DEG), 290.6 (F DEG)

UPPER SHELF EXPANSION: 0.833 (MM), 0.0328 (IN)

UPPER SHELF EXPANSION: 0.833 (MM), 0.0328 (IN)

NOTE: NONE

MODEL SET NAME: 7

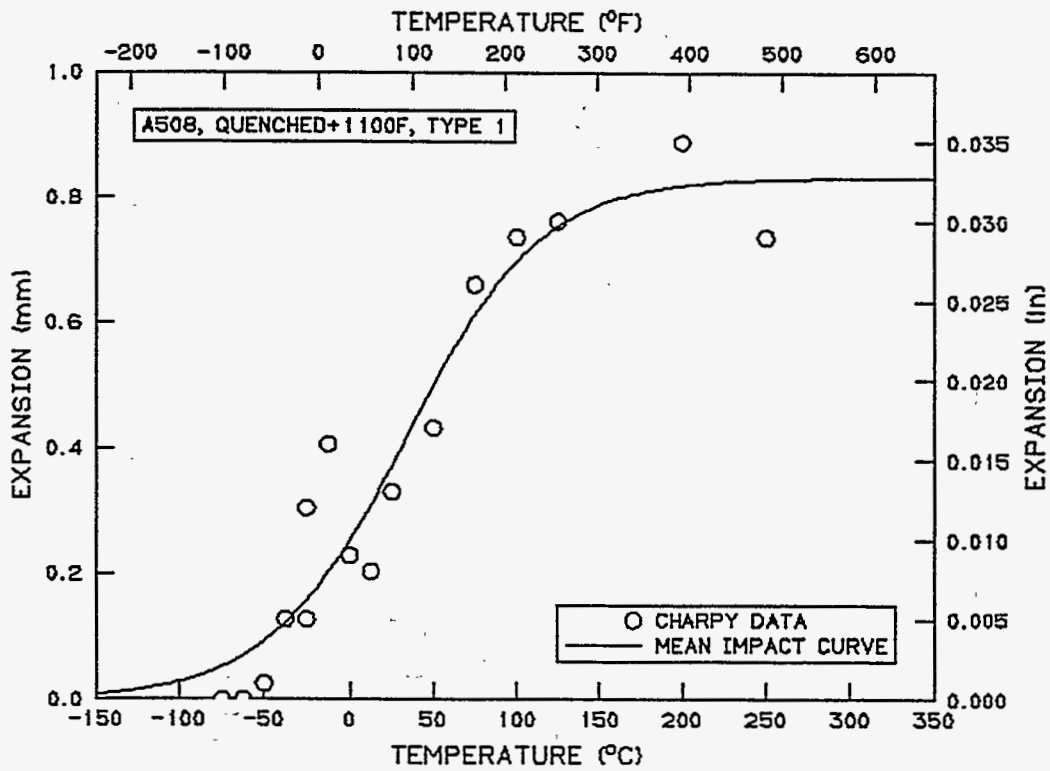

SOURCE: A5081100.T1 ANALYSIS SET

Y VARIABLE: SHEAR

MODEL PARAMETERS

LOWER SHELF SHEAR [HELD FIXED]: 0 (PERCENT)

MID-TRANSITION TEMPERATURE: 52.5 (DEG C), 126.6 (DEG F)

TRANSITION ZONE WIDTH: 65.2 (C DEG), 117.4 (F DEG)

UPPER SHELF SHEAR [HELD FIXED]: 100 (PERCENT)

UPPER SHELF SHEAR: 100 (PERCENT)

TEMPERATURE [50 (PERCENT), 50 (PERCENT) SHEAR]: 52.5 (DEG C), 126.6 (DEG F)

NOTE: NONE

MODEL SET NAME: 6

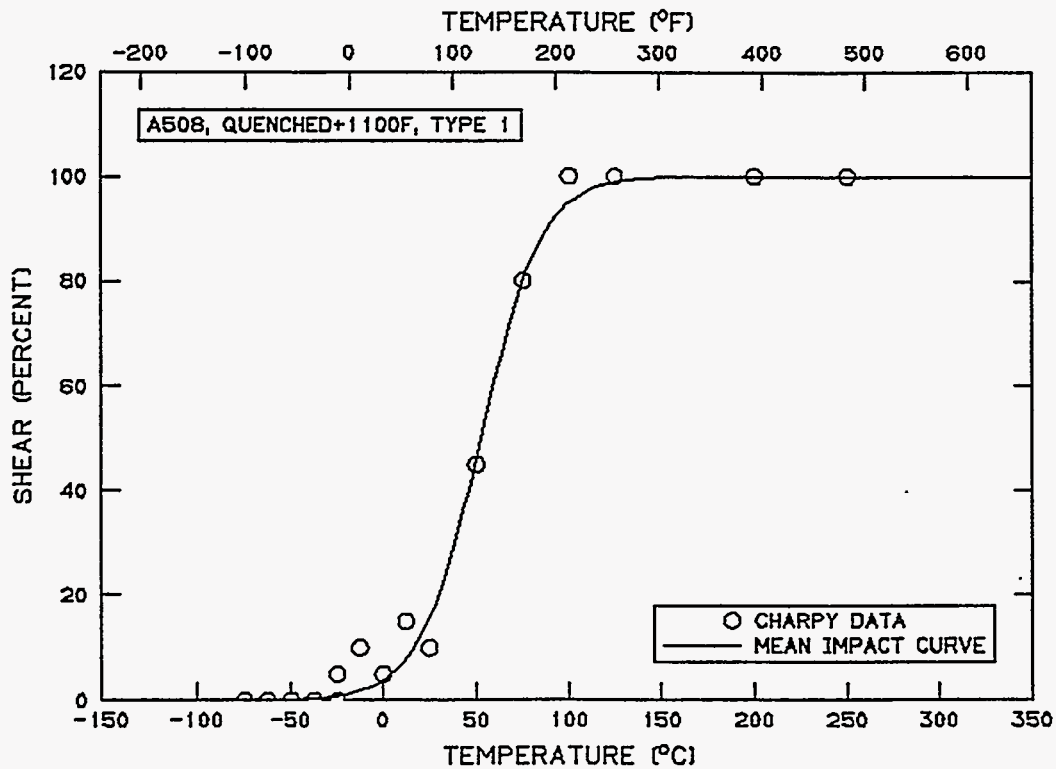

SOURCE: ANALYSIS SET
ANALYSIS SET NAME: A5081100.T2

SET NAME: A5081100.T2
NOTE: A508 QUENCHED+1100F, TYPE 2

IDENT	TEMPERATURE		ENERGY (J)	EXPANSION (FT-LB)	EXPANSION		SHEAR (PERCENT)
	(DEG C)	(DEG F)			(MM)	(IN)	
317B	-100.0	-148.0	0.20	0.15	0.00	0.000	0.0
39A	-75.0	-103.0	0.46	0.34	0.00	0.000	0.0
338A	-62.5	-80.5	2.03	1.50	0.00	0.000	0.0
39D	-50.0	-58.0	0.99	0.73	0.00	0.000	0.0
338B	-37.5	-35.5	2.75	2.03	0.05	0.002	5.0
39B	-25.0	-13.0	2.62	1.93	0.08	0.003	10.0
338C	-12.5	9.5	3.59	2.65	0.15	0.006	20.0
39C	0.0	32.0	2.36	1.74	0.05	0.002	10.0
338D	12.5	54.5	4.49	3.31	0.25	0.010	60.0
310C	25.0	77.0	4.73	3.49	0.28	0.011	45.0
317A	37.5	99.5	4.04	2.98	0.23	0.009	50.0
310A	50.0	122.0	4.87	3.59	0.33	0.013	75.0
310D	100.0	212.0	4.80	3.54	0.36	0.014	100.0
317C	150.0	302.0	5.45	4.02	0.43	0.017	100.0
310B	200.0	392.0	5.69	4.20	0.43	0.017	100.0

NUMBER OF SPECIMENS: 15

SOURCE: A5081100.T2 ANALYSIS SET

Y VARIABLE: ENERGY

MODEL PARAMETERS

LOWER SHELF ENERGY [HELD FIXED]: 0.1 (J), 0.1 (FT-LB)

MID-TRANSITION TEMPERATURE: -21.5 (DEG C), -6.7 (DEG F)

TRANSITION ZONE WIDTH: 134.2 (C DEG), 241.6 (F DEG)

UPPER SHELF ENERGY: 5.4 (J), 4.0 (FT-LB)

UPPER SHELF ENERGY: 5.4 (J), 4.0 (FT-LB)

NOTE: NONE

MODEL SET NAME: 6

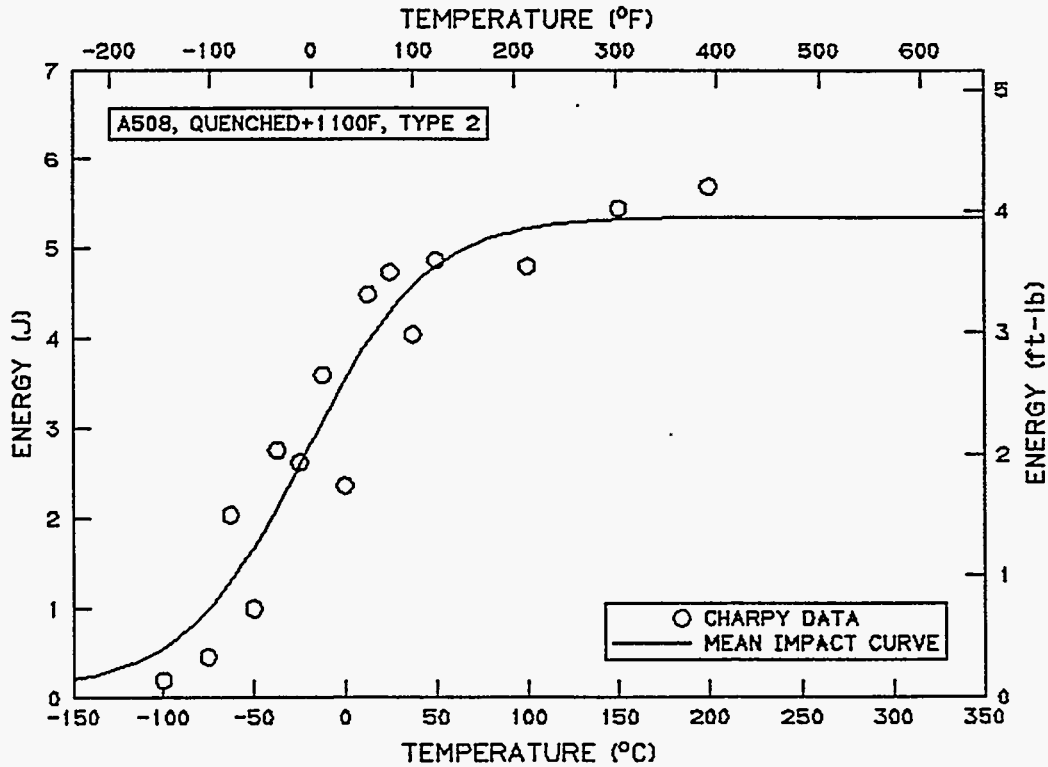

SOURCE: A5081100.T2 ANALYSIS SET

Y VARIABLE: EXPANSION

MODEL PARAMETERS

LOWER SHELF EXPANSION [HELD FIXED]: 0.000 (MM), 0.0000 (IN)

MID-TRANSITION TEMPERATURE: 16.9 (DEG C), 62.4 (DEG F)

TRANSITION ZONE WIDTH: 106.6 (C DEG), 191.9 (F DEG)

UPPER SHELF EXPANSION: 0.414 (MM), 0.0163 (IN)

UPPER SHELF EXPANSION: 0.414 (MM), 0.0163 (IN)

NOTE: NONE

MODEL SET NAME: 5

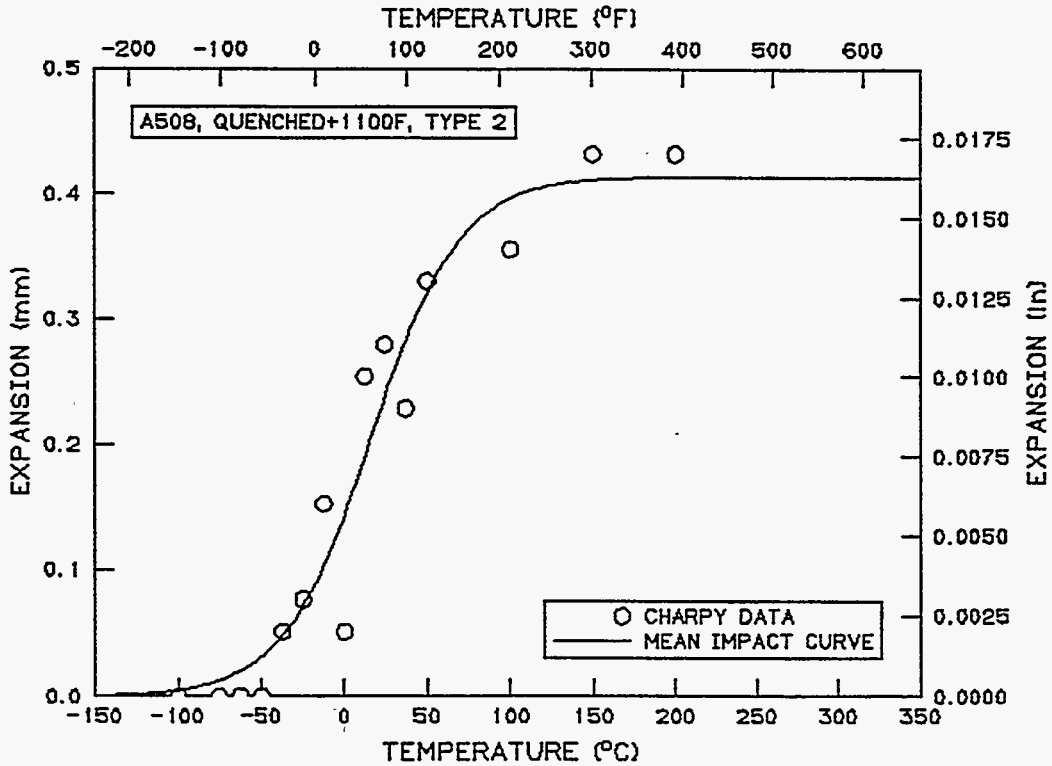

SOURCE: A5081100.T2 ANALYSIS SET

Y VARIABLE: SHEAR

MODEL PARAMETERS

LOWER SHELF SHEAR [HELD FIXED]: 0 (PERCENT)

MID-TRANSITION TEMPERATURE: 26.5 (DEG C), 79.7 (DEG F)

TRANSITION ZONE WIDTH: 95.8 (C DEG), 172.5 (F DEG)

UPPER SHELF SHEAR [HELD FIXED]: 100 (PERCENT)

UPPER SHELF SHEAR: 100 (PERCENT)

TEMPERATURE [50 (PERCENT), 50 (PERCENT) SHEAR]: 26.5 (DEG C), 79.7 (DEG F)

NOTE: NONE

MODEL SET NAME: 4

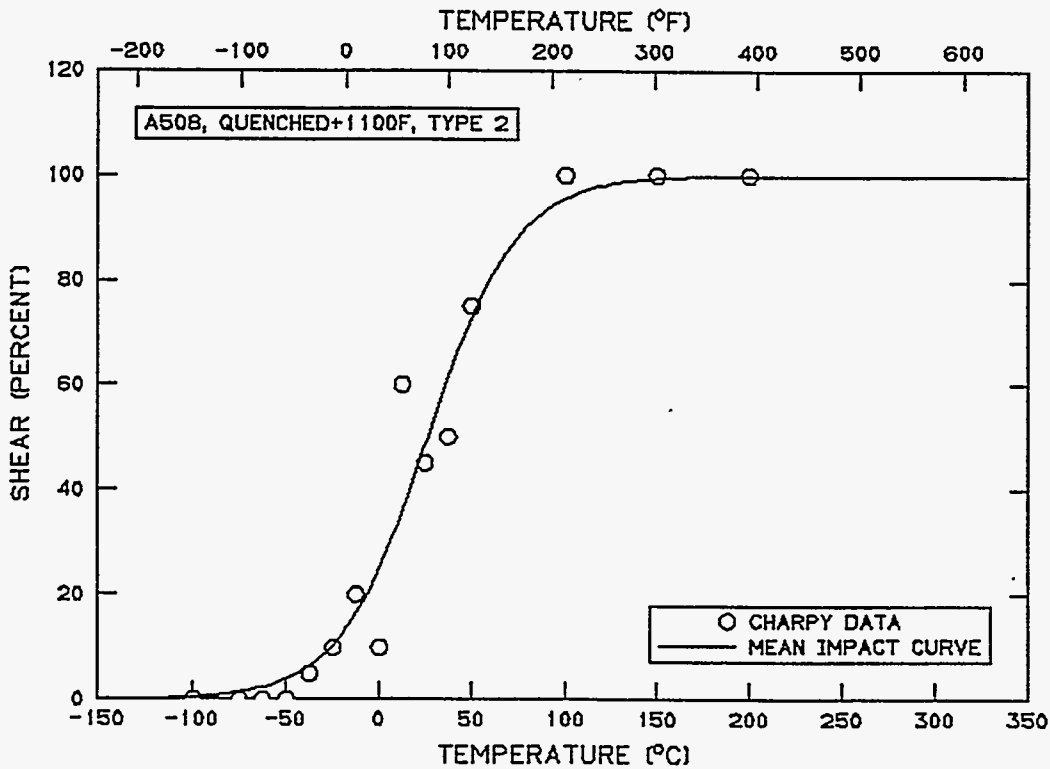

SOURCE: ANALYSIS SET
ANALYSIS SET NAME: A5081100.T3

SET NAME: A5081100.T3
NOTE: A508 QUENCHED+1100F, TYPE 3

IDENT	TEMPERATURE		ENERGY (J)	(FT-LB)	EXPANSION		SHEAR (PERCENT)
	(DEG C)	(DEG F)			(MM)	(IN)	
321D	-125.0	-193.0	0.81	0.60	0.00	0.000	0.0
317B	-100.0	-148.0	1.22	0.90	0.00	0.000	0.0
317C	-87.5	-125.5	2.03	1.50	0.00	0.000	0.0
317A	-75.0	-103.0	3.39	2.50	0.00	0.000	0.0
317D	-62.5	-80.5	1.90	1.40	0.00	0.000	0.0
313D	-50.0	-58.0	4.75	3.50	0.08	0.003	0.0
313C	-37.5	-35.5	5.56	4.10	0.13	0.005	0.0
313B	-25.0	-13.0	5.97	4.40	0.18	0.007	5.0
313A	-12.5	9.5	6.91	5.10	0.20	0.008	5.0
320A	0.0	32.0	8.13	6.00	0.30	0.012	15.0
320B	25.0	77.0	8.13	6.00	0.28	0.011	20.0
320C	50.0	122.0	11.93	8.80	0.51	0.020	65.0
320D	100.0	212.0	13.15	9.70	0.56	0.022	90.0
321B	150.0	302.0	14.78	10.90	0.71	0.028	100.0
321A	200.0	392.0	15.19	11.20	0.66	0.026	100.0
321C	250.0	482.0	14.51	10.70	0.66	0.026	100.0

NUMBER OF SPECIMENS: 16

SOURCE: A5081100.T3 ANALYSIS SET

Y VARIABLE: ENERGY

MODEL PARAMETERS

LOWER SHELF ENERGY [HELD FIXED]: 0.1 (J), 0.1 (FT-LB)

MID-TRANSITION TEMPERATURE: -2.1 (DEG C), 28.2 (DEG F)

TRANSITION ZONE WIDTH: 188.3 (C DEG), 338.9 (F DEG)

UPPER SHELF ENERGY: 15.0 (J), 11.1 (FT-LB)

UPPER SHELF ENERGY: 15.0 (J), 11.1 (FT-LB)

NOTE: NONE

MODEL SET NAME: 7

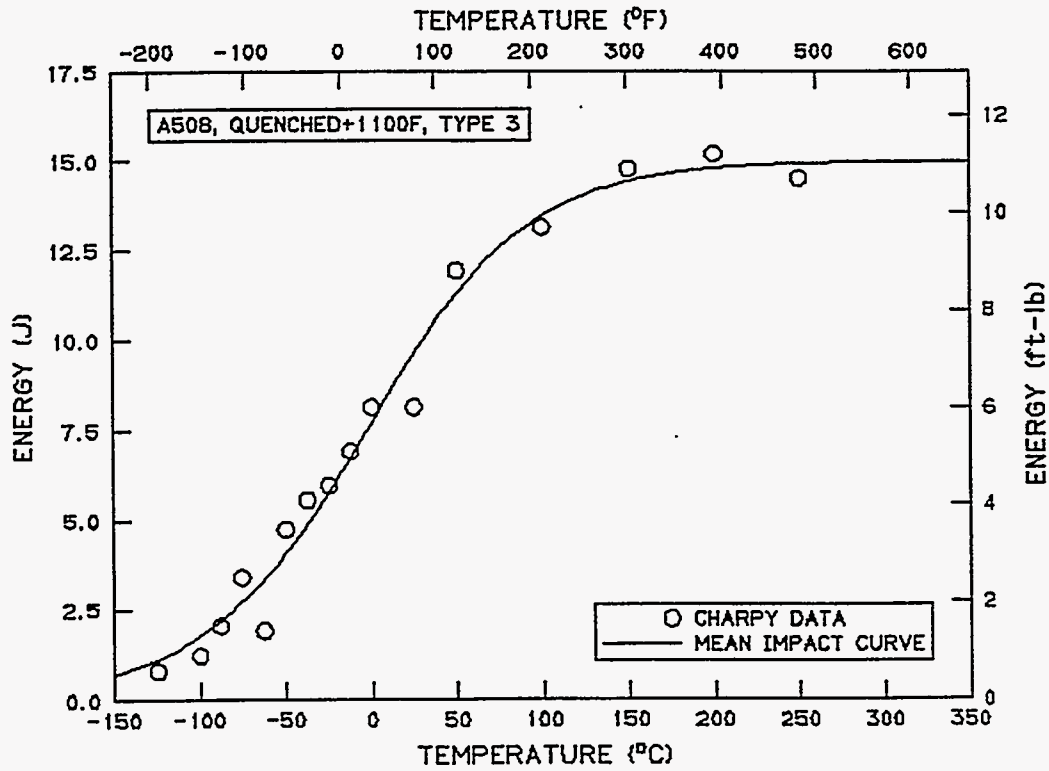

SOURCE: A5081100.T3 ANALYSIS SET

Y VARIABLE: EXPANSION

MODEL PARAMETERS

LOWER SHELF EXPANSION [HELD FIXED]: 0.000 (MM), 0.0000 (IN)

MID-TRANSITION TEMPERATURE: 19.6 (DEG C), 67.3 (DEG F)

TRANSITION ZONE WIDTH: 138.6 (C DEG), 249.5 (F DEG)

UPPER SHELF EXPANSION: 0.670 (MM), 0.0264 (IN)

UPPER SHELF EXPANSION: 0.670 (MM), 0.0264 (IN)

NOTE: NONE

MODEL SET NAME: 8

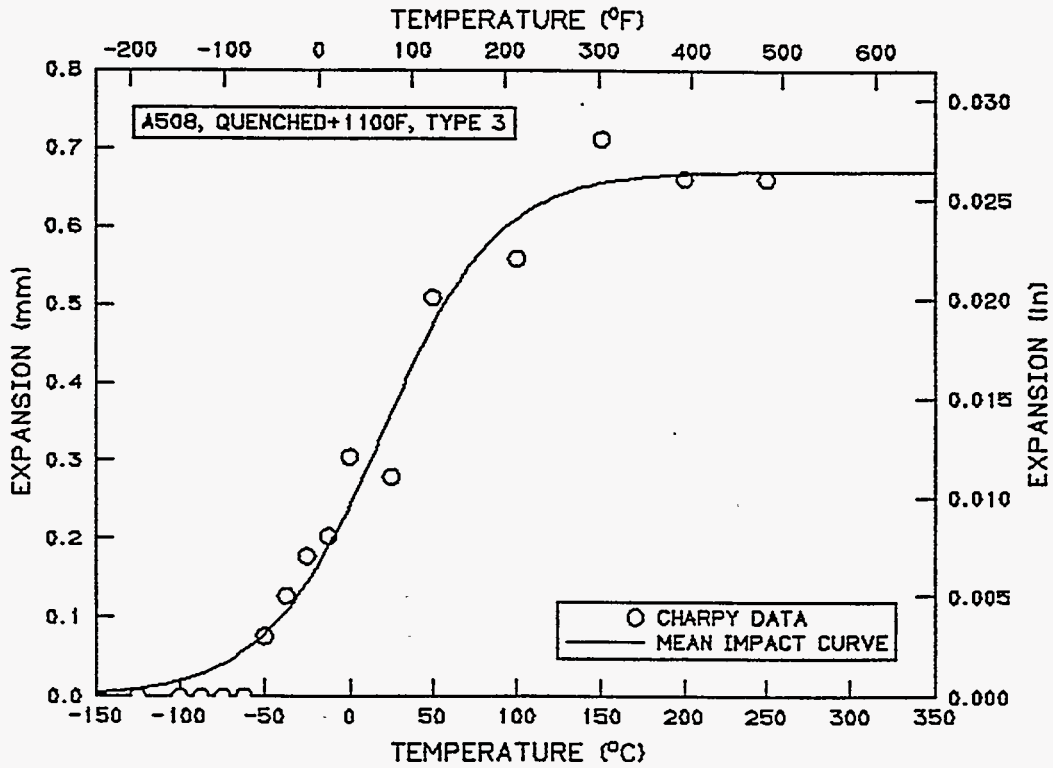

SOURCE: A5081100.T3 ANALYSIS SET

Y VARIABLE: SHEAR

MODEL PARAMETERS

LOWER SHELF SHEAR [HELD FIXED]: 0 (PERCENT)

MID-TRANSITION TEMPERATURE: 42.7 (DEG C), 108.8 (DEG F)

TRANSITION ZONE WIDTH: 74.1 (C DEG), 133.3 (F DEG)

UPPER SHELF SHEAR [HELD FIXED]: 100 (PERCENT)

UPPER SHELF SHEAR: 100 (PERCENT)

TEMPERATURE [50 (PERCENT), 50 (PERCENT) SHEAR]: 42.7 (DEG C), 108.8 (DEG F)

NOTE: NONE

MODEL SET NAME: 9

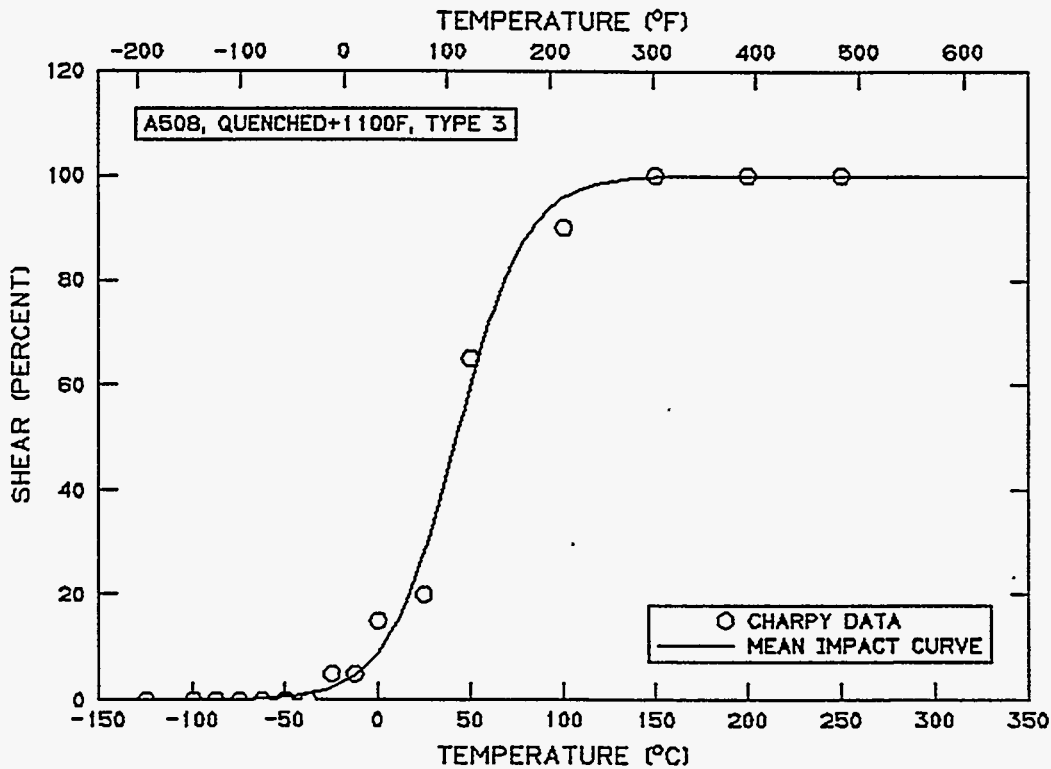

SOURCE: ANALYSIS SET
 ANALYSIS SET NAME: A5081100.T4

SET NAME: A5081100.T4
 NOTE: A508 QUENCHED+1100F, TYPE 4

IDENT	TEMPERATURE		ENERGY (J)	(FT-LB)	EXPANSION		SHEAR (PERCENT)
	(DEG C)	(DEG F)			(MM)	(IN)	
313A	-75.0	-103.0	0.39	0.29	0.00	0.000	0.0
313B	-50.0	-58.0	0.66	0.49	0.00	0.000	0.0
313C	-37.5	-35.5	0.66	0.49	0.00	0.000	0.0
313D	-25.0	-13.0	1.98	1.46	0.05	0.002	5.0
311F	-12.5	9.5	1.79	1.32	0.03	0.001	5.0
311E	0.0	32.0	4.79	3.53	0.36	0.014	60.0
311D	12.5	54.5	4.60	3.39	0.36	0.014	85.0
33A	25.0	77.0	2.32	1.71	0.13	0.005	40.0
311C	37.5	99.5	3.10	2.29	0.15	0.006	45.0
33B	50.0	122.0	3.16	2.33	0.25	0.010	55.0
311B	62.5	144.5	6.14	4.53	0.46	0.018	100.0
33C	75.0	167.0	4.72	3.48	0.30	0.012	85.0
33D	100.0	212.0	6.01	4.43	0.53	0.021	100.0
33E	150.0	302.0	4.60	3.39	0.41	0.016	100.0
33F	200.0	392.0	5.04	3.72	0.41	0.016	100.0
311A	250.0	482.0	5.04	3.72	0.48	0.019	100.0

NUMBER OF SPECIMENS: 16

SOURCE: A5081100.T4 ANALYSIS SET

Y VARIABLE: ENERGY

MODEL PARAMETERS

LOWER SHELF ENERGY [HELD FIXED]: 0.1 (J), 0.1 (FT-LB)

MID-TRANSITION TEMPERATURE: -7.0 (DEG C), 19.4 (DEG F)

TRANSITION ZONE WIDTH: 111.5 (C DEG), 200.8 (F DEG)

UPPER SHELF ENERGY: 5.1 (J), 3.7 (FT-LB)

UPPER SHELF ENERGY: 5.1 (J), 3.7 (FT-LB)

NOTE: NONE

MODEL SET NAME: 2

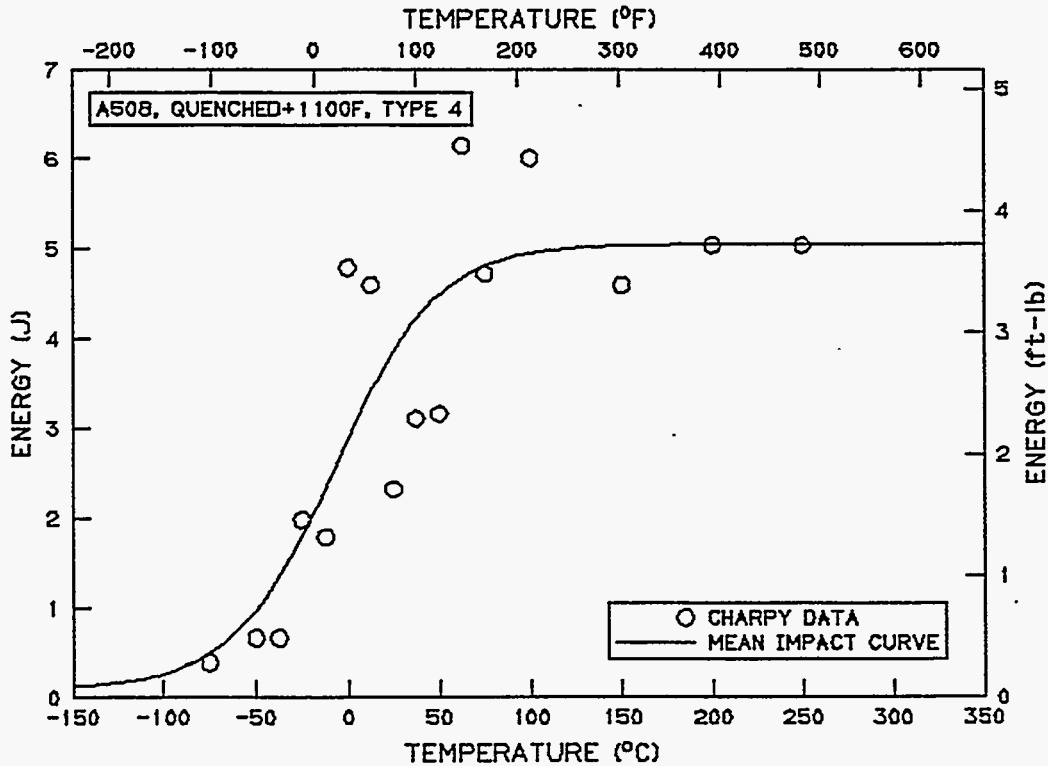

SOURCE: A5081100.T4 ANALYSIS SET

Y VARIABLE: EXPANSION

MODEL PARAMETERS

LOWER SHELF EXPANSION [HELD FIXED]: 0.000 (MM), 0.0000 (IN)

MID-TRANSITION TEMPERATURE: 22.5 (DEG C), 72.5 (DEG F)

TRANSITION ZONE WIDTH: 127.0 (C DEG), 228.6 (F DEG)

UPPER SHELF EXPANSION: 0.451 (MM), 0.0178 (IN)

UPPER SHELF EXPANSION: 0.451 (MM), 0.0178 (IN)

NOTE: NONE

MODEL SET NAME: 1

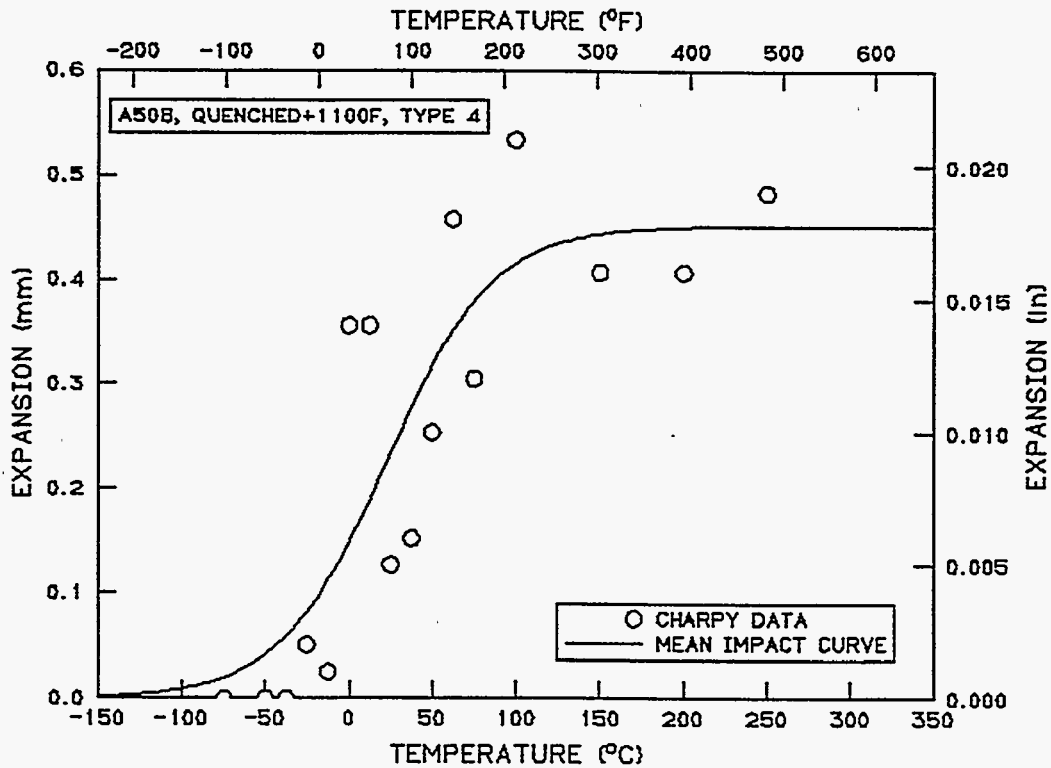

SOURCE: A5081100.T4 ANALYSIS SET

Y VARIABLE: SHEAR

MODEL PARAMETERS

LOWER SHELF SHEAR [HELD FIXED]: 0 (PERCENT)

MID-TRANSITION TEMPERATURE: 19.8 (DEG C), 67.7 (DEG F)

TRANSITION ZONE WIDTH: 111.0 (C DEG), 199.8 (F DEG)

UPPER SHELF SHEAR [HELD FIXED]: 100 (PERCENT)

UPPER SHELF SHEAR: 100 (PERCENT)

TEMPERATURE [50 (PERCENT), 50 (PERCENT) SHEAR]: 19.8 (DEG C), 67.7 (DEG F)

NOTE: NONE

MODEL SET NAME: 0

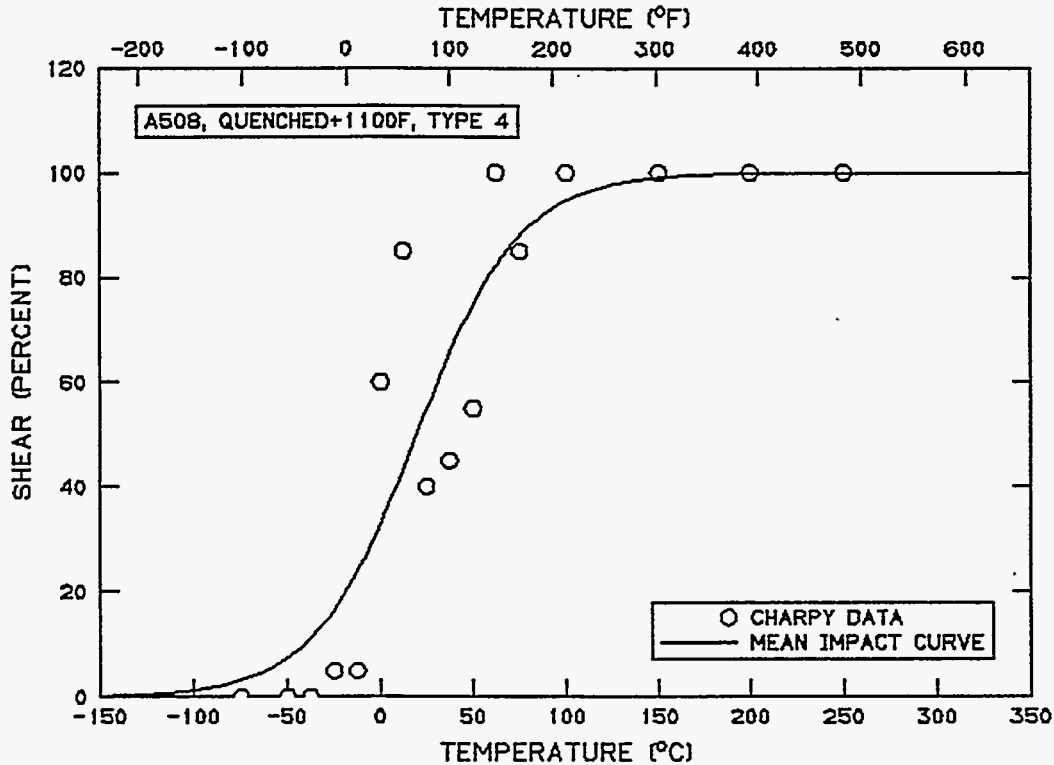

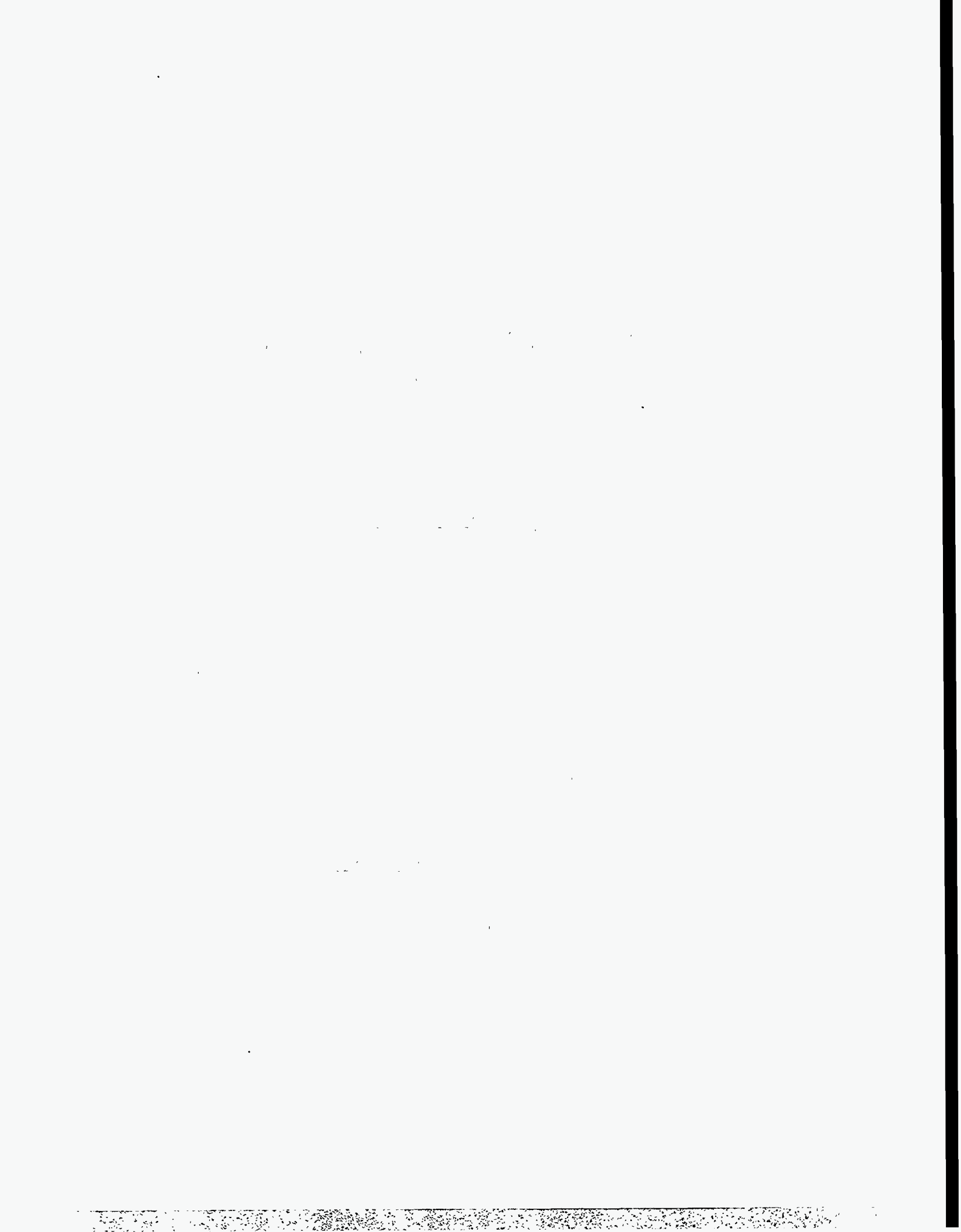

APPENDIX E

A 508, QUENCHED AND TEMPERED AT 677°C

SOURCE: ANALYSIS SET
ANALYSIS SET NAME: 508_1250.F

SET NAME: 508_1250.F
NOTE: A508, QUENCHED & TEMPERED @ 1250 F

IDENT	TEMPERATURE		ENERGY		EXPANSION		SHEAR (PERCENT)
	(DEG C)	(DEG F)	(J)	(FT-LB)	(MM)	(IN)	
5SC-20	10.0	50.0	32.00	23.60	0.43	0.017	5.0
5SC-8	23.0	73.4	45.00	33.19	0.64	0.025	20.0
5SC-16	38.0	100.4	71.00	52.37	1.04	0.041	40.0
5SC-22	38.0	100.4	77.00	56.79	1.19	0.047	55.0
5SC-14	43.0	109.4	99.00	73.02	1.45	0.057	75.0
5SC-10	66.0	150.8	99.00	73.02	1.45	0.057	80.0
5SC-18	93.0	199.4	111.00	81.87	1.68	0.066	100.0
5SC-12	121.0	249.8	122.00	89.98	1.68	0.066	100.0

NUMBER OF SPECIMENS: 8

ANALYSIS SET: 508_1250.F

Y VARIABLE: ENERGY

MODEL PARAMETERS

LOWER SHELF ENERGY [HELD FIXED]: 2.7 (J), 2.0 (FT-LB)

MID-TRANSITION TEMPERATURE: 28.0 (DEG C), 82.5 (DEG F)

TRANSITION ZONE WIDTH: 60.7 (C DEG), 109.2 (F DEG)

UPPER SHELF ENERGY: 115.8 (J), 85.4 (FT-LB)

UPPER SHELF ENERGY: 115.8 (J), 85.4 (FT-LB)

TEMPERATURE [41 (J), 30.2 (FT-LB) ENERGY]: 17.9 (DEG C), 64.2 (DEG F)

TEMPERATURE [68 (J), 50.2 (FT-LB) ENERGY]: 32.8 (DEG C), 91.0 (DEG F)

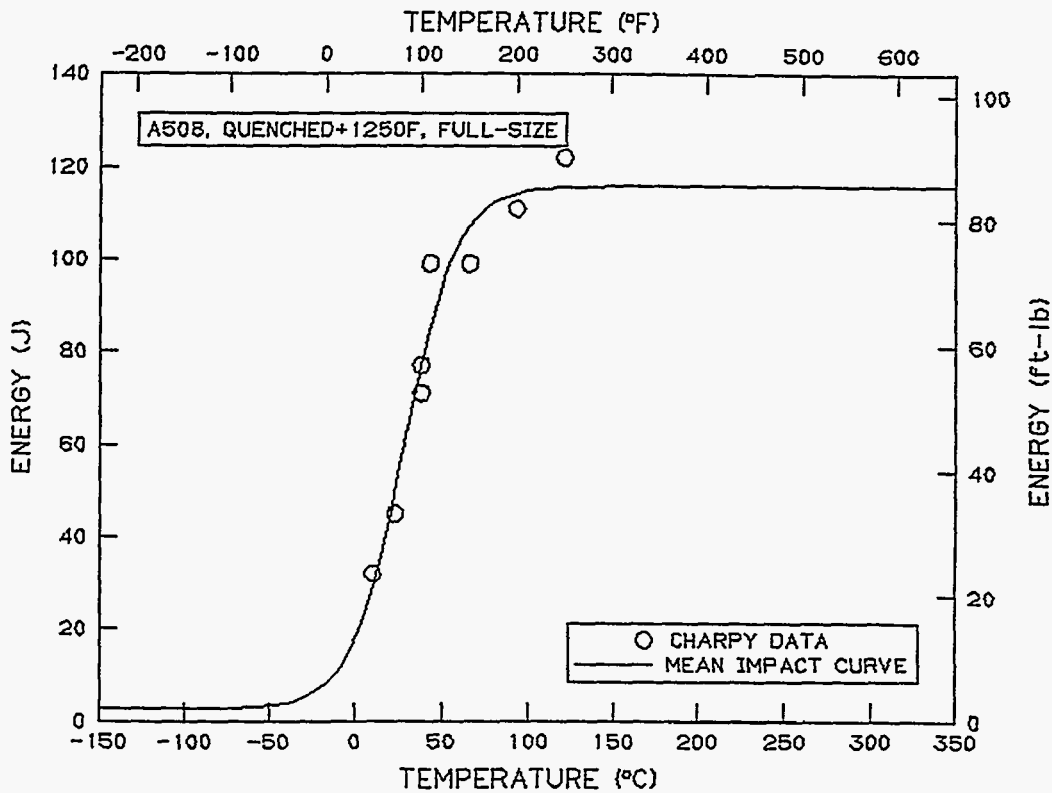

NOTE: A508, QUENCHED & TEMPERED @ 1250 F, FULL-SIZE
MODEL SET NAME: 508-1250.F

ANALYSIS SET: 508_1250.F

Y VARIABLE: EXPANSION

MODEL PARAMETERS

LOWER SHELF EXPANSION [HELD FIXED]: 0.061 (MM), 0.0024 (IN)

MID-TRANSITION TEMPERATURE: 27.9 (DEG C), 82.2 (DEG F)

TRANSITION ZONE WIDTH: 51.1 (C DEG), 92.0 (F DEG)

UPPER SHELF EXPANSION: 1.654 (MM), 0.0651 (IN)

UPPER SHELF EXPANSION: 1.654 (MM), 0.0651 (IN)

TEMPERATURE [0.89 (MM), 0.035 (IN) EXPANSION]: 29.0 (DEG C), 84.1 (DEG F)

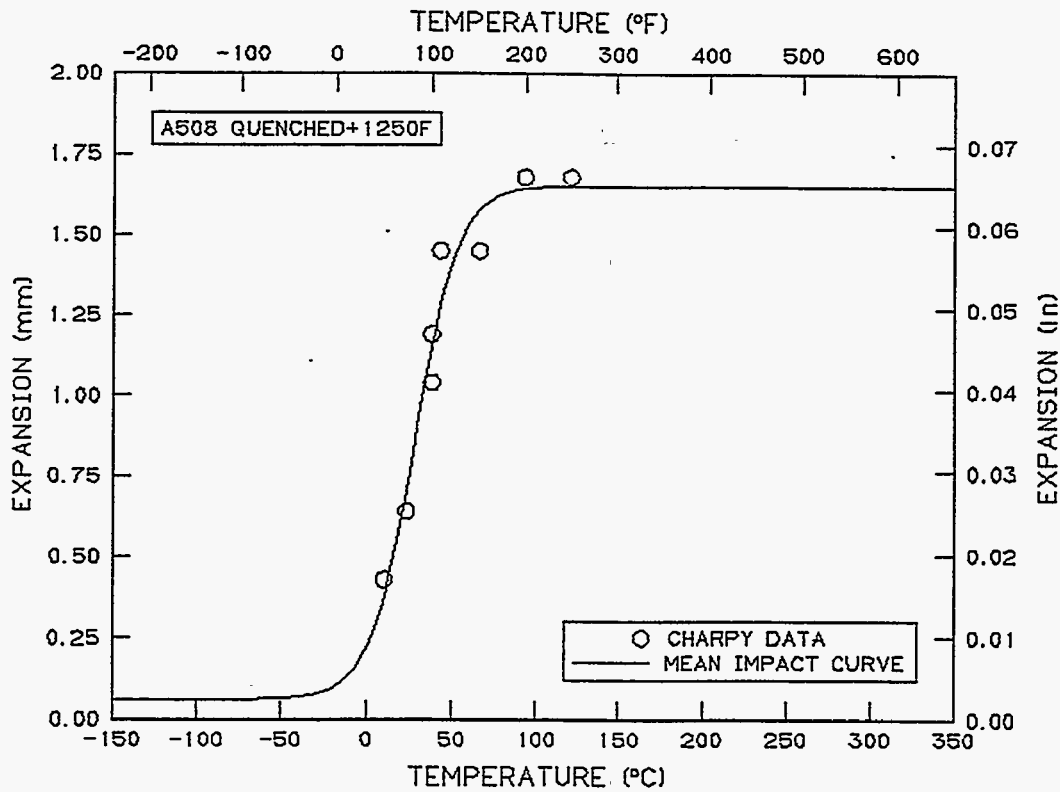

NOTE: A508, QUENCHED+1250F, FULL-SIZE
MODEL SET NAME: 508_1250.FE

DATA SOURCE: ANALYSIS SET

ANALYSIS SET: 508_1250.F

Y VARIABLE: SHEAR

MODEL PARAMETERS

LOWER SHELF SHEAR [HELD FIXED]: 0 (PERCENT)

MID-TRANSITION TEMPERATURE: 37.5 (DEG C), 99.5 (DEG F)

TRANSITION ZONE WIDTH: 44.3 (C DEG), 79.7 (F DEG)

UPPER SHELF SHEAR [HELD FIXED]: 100 (PERCENT)

UPPER SHELF SHEAR: 100 (PERCENT)

TEMPERATURE [50 (PERCENT), 50 (PERCENT) SHEAR]: 37.5 (DEG C), 99.5 (DEG F)

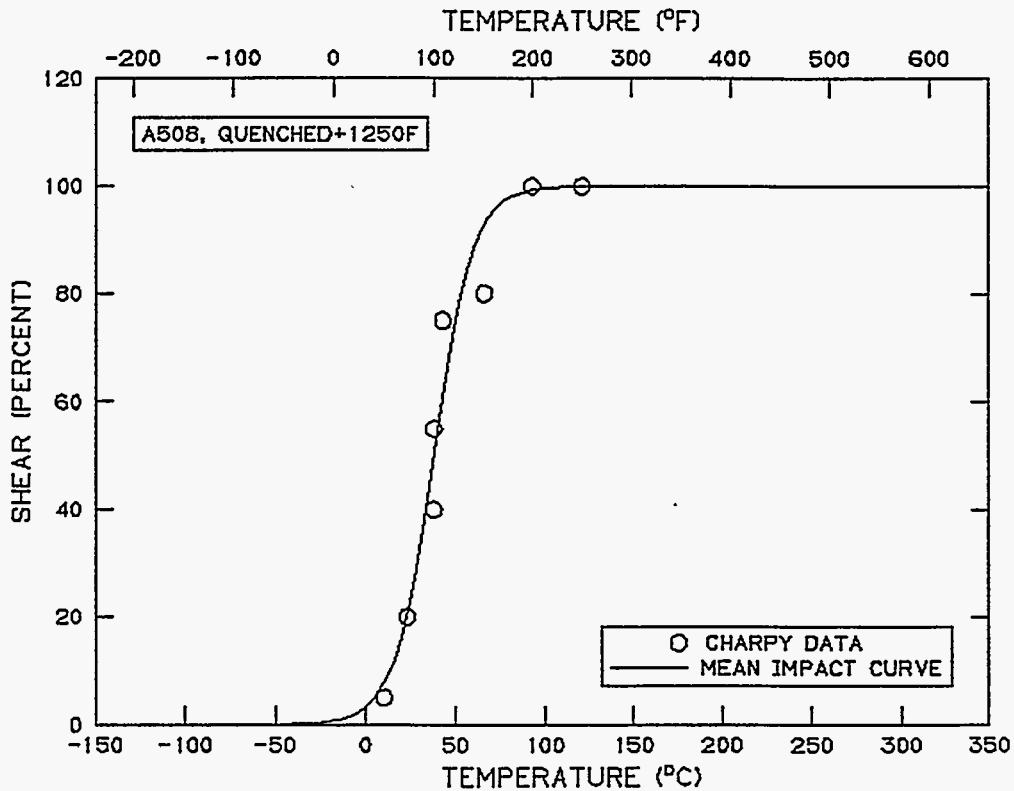

REMARK: A508, QUENCHED+1250F, FULL-SIZE

MODEL SET NAME: 508_1250.FS

SOURCE: ANALYSIS SET
ANALYSIS SET NAME: A5081250.T1

SET NAME: A5081250.T1
NOTE: A508 QUENCHED+1250F, TYPE 1 SPEC.

IDENT	TEMPERATURE		ENERGY (J)	(FT-LB)	EXPANSION		SHEAR (PERCENT)
	(DEG C)	(DEG F)			(MM)	(IN)	
519C	-125.0	-193.0	1.06	0.78	0.00	0.000	0.0
519B	-100.0	-148.0	4.12	3.04	0.00	0.000	0.0
519D	-87.5	-125.5	7.44	5.49	0.18	0.007	0.0
519A	-75.0	-103.0	5.79	4.27	0.08	0.003	0.0
520A	-62.5	-80.5	3.54	2.61	0.03	0.001	0.0
59D	-50.0	-58.0	10.14	7.48	0.28	0.011	5.0
520B	-37.5	-35.5	1.59	1.17	0.00	0.000	0.0
520D	-37.5	-35.5	13.21	9.74	0.56	0.022	15.0
59C	-25.0	-13.0	19.17	14.14	0.69	0.027	45.0
520C	-12.5	9.5	12.41	9.15	0.43	0.017	15.0
59B	0.0	32.0	24.91	18.37	0.81	0.032	70.0
57A	25.0	77.0	18.43	13.59	0.64	0.025	50.0
57B	50.0	122.0	30.26	22.32	0.86	0.034	100.0
57C	75.0	167.0	26.90	19.84	0.79	0.031	100.0
57D	100.0	212.0	23.86	17.60	0.94	0.037	100.0
59A	250.0	482.0	23.81	17.56	0.76	0.030	100.0

NUMBER OF SPECIMENS: 16

SOURCE: A5081250.T1 ANALYSIS SET

Y VARIABLE: ENERGY

MODEL PARAMETERS

LOWER SHELF ENERGY [HELD FIXED]: 0.1 (J), 0.1 (FT-LB)

MID-TRANSITION TEMPERATURE: -28.7 (DEG C), -19.7 (DEG F)

TRANSITION ZONE WIDTH: 114.9 (C DEG), 206.9 (F DEG)

UPPER SHELF ENERGY: 26.2 (J), 19.4 (FT-LB)

UPPER SHELF ENERGY: 26.2 (J), 19.4 (FT-LB)

NOTE: A508, QUENCHED+1250F, TYPE 1

MODEL SET NAME: 7

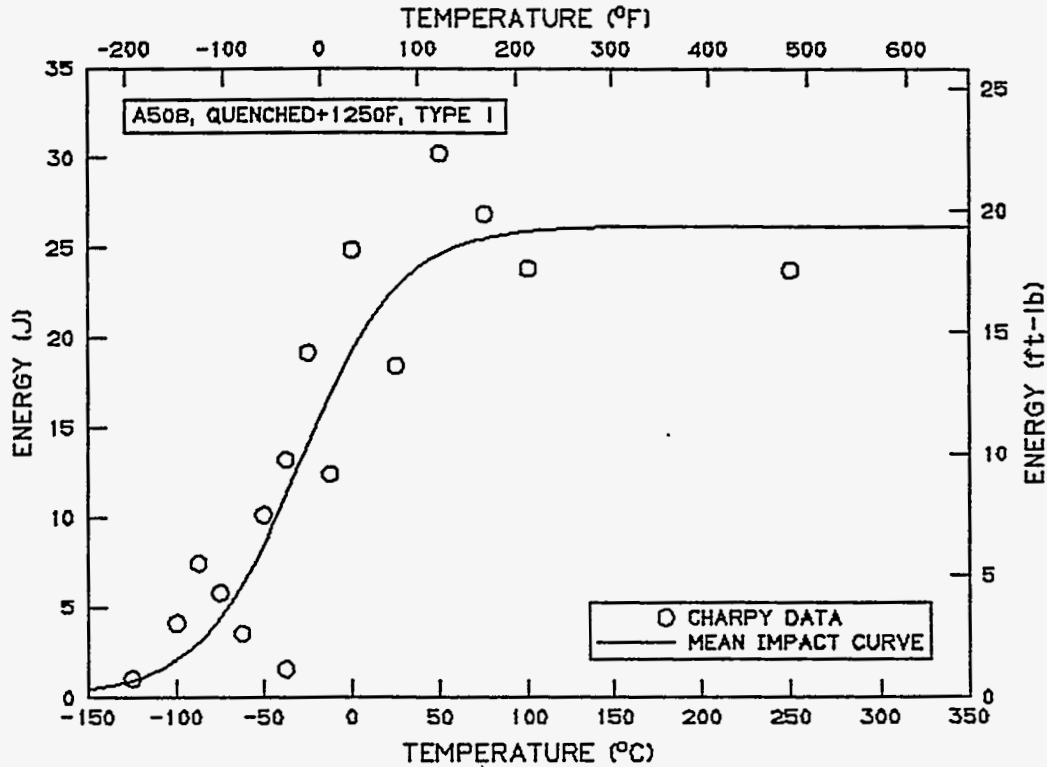

SOURCE: A5081250.T1 ANALYSIS SET

Y VARIABLE: EXPANSION

MODEL PARAMETERS

LOWER SHELF EXPANSION [HELD FIXED]: 0.000 (MM), 0.0000 (IN)

MID-TRANSITION TEMPERATURE: -31.3 (DEG C), -24.4 (DEG F)

TRANSITION ZONE WIDTH: 75.3 (C DEG), 135.6 (F DEG)

UPPER SHELF EXPANSION: 0.820 (MM), 0.0323 (IN)

UPPER SHELF EXPANSION: 0.820 (MM), 0.0323 (IN)

NOTE: A508, QUENCHED+1250F, TYPE 1

MODEL SET NAME: 8

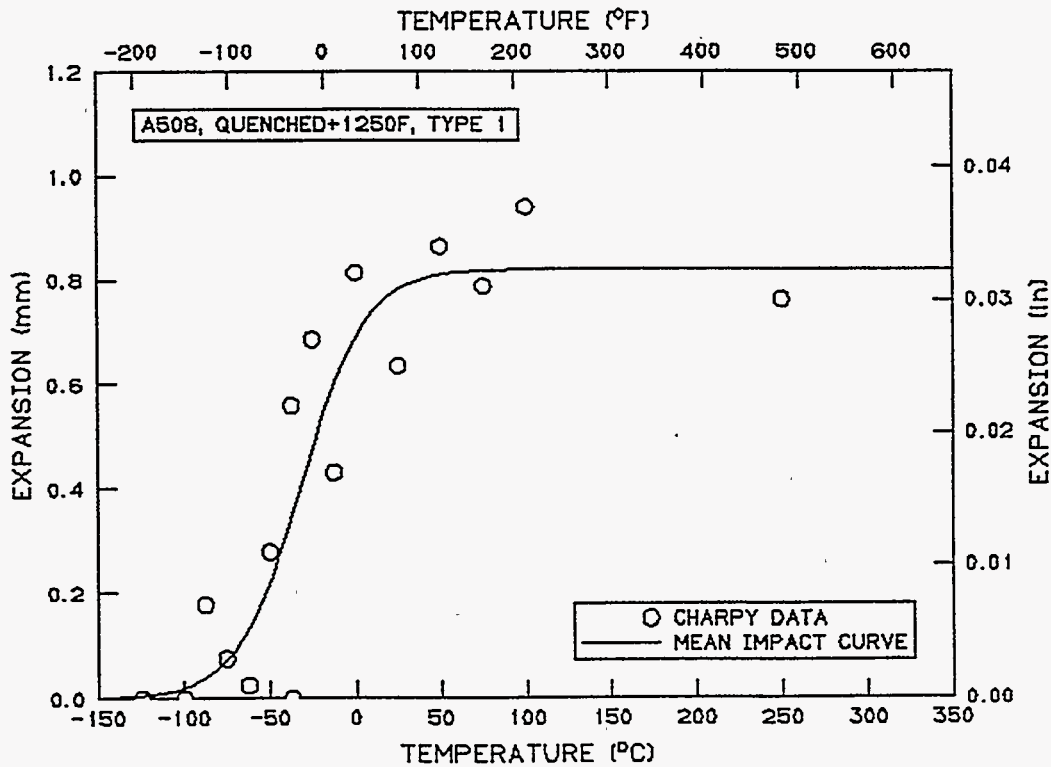

SOURCE: A5081250.T1 ANALYSIS SET

Y VARIABLE: SHEAR

MODEL PARAMETERS

LOWER SHELF SHEAR [HELD FIXED]: 0 (PERCENT)

MID-TRANSITION TEMPERATURE: 2.8 (DEG C), 37.0 (DEG F)

TRANSITION ZONE WIDTH: 89.0 (C DEG), 160.1 (F DEG)

UPPER SHELF SHEAR [HELD FIXED]: 100 (PERCENT)

UPPER SHELF SHEAR: 100 (PERCENT)

TEMPERATURE [50 (PERCENT), 50 (PERCENT) SHEAR]: 2.8 (DEG C), 37.0 (DEG F)

NOTE: NONE

MODEL SET NAME: 0

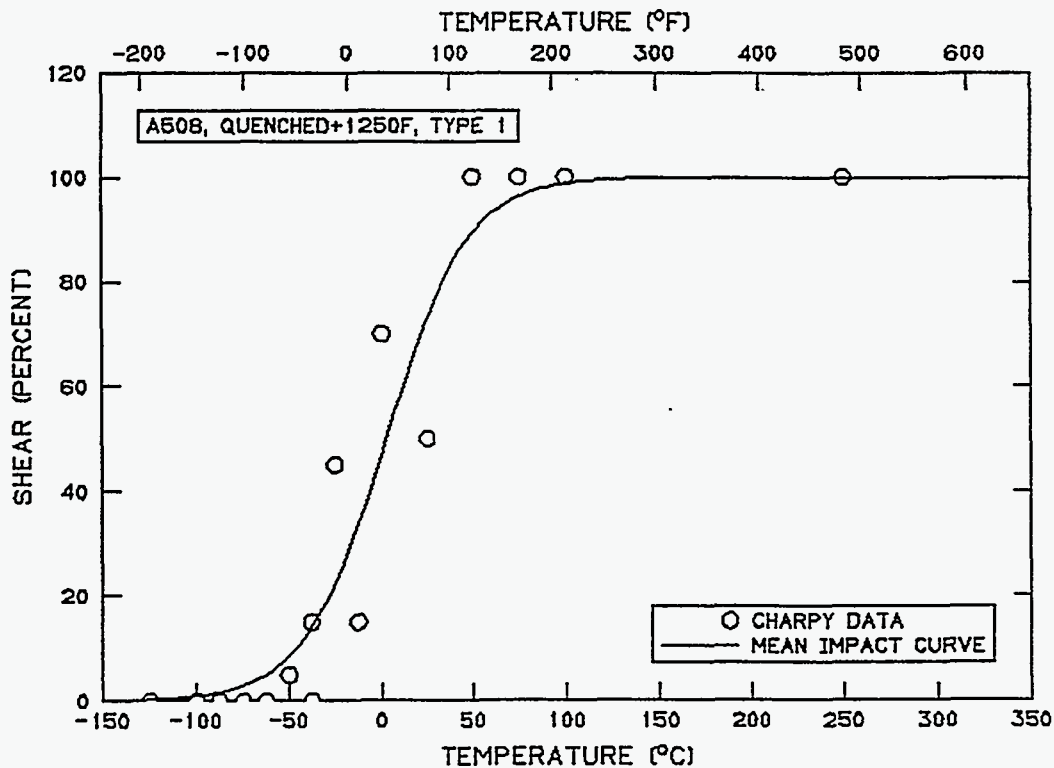

SOURCE: ANALYSIS SET
ANALYSIS SET NAME: A5081250.T2

SET NAME: A5081250.T2
NOTE: A508 QUENCHED+1250F, TYPE 2

IDENT	TEMPERATURE		ENERGY	EXPANSION			SHEAR
	(DEG C)	(DEG F)	(J)	(FT-LB)	(MM)	(IN)	(PERCENT)
519B	-100.0	-148.0	0.99	0.73	0.00	0.000	0.0
519C	-87.5	-125.5	0.39	0.29	0.00	0.000	0.0
519A	-75.0	-103.0	0.60	0.44	0.00	0.000	0.0
519D	-62.5	-80.5	3.53	2.60	0.18	0.007	10.0
59D	-50.0	-58.0	3.34	2.46	0.15	0.006	10.0
517A	-37.5	-35.5	4.42	3.26	0.25	0.010	10.0
59C	-25.0	-13.0	5.38	3.97	0.30	0.012	60.0
517B	-12.5	9.5	6.85	5.05	0.48	0.019	100.0
59B	0.0	32.0	6.40	4.72	0.46	0.018	80.0
517C	12.5	54.5	7.78	5.74	0.53	0.021	100.0
59A	25.0	77.0	6.28	4.63	0.38	0.015	70.0
517D	100.0	212.0	6.21	4.58	0.46	0.018	100.0
513A	150.0	302.0	6.85	5.05	0.48	0.019	100.0

NUMBER OF SPECIMENS: 13

SOURCE: A5081250.T2 ANALYSIS SET

Y VARIABLE: ENERGY

MODEL PARAMETERS

LOWER SHELF ENERGY [HELD FIXED]: 0.1 (J), 0.1 (FT-LB)

MID-TRANSITION TEMPERATURE: -51.4 (DEG C), -60.5 (DEG F)

TRANSITION ZONE WIDTH: 65.3 (C DEG), 117.5 (F DEG)

UPPER SHELF ENERGY: 6.8 (J), 5.0 (FT-LB)

UPPER SHELF ENERGY: 6.8 (J), 5.0 (FT-LB)

NOTE: NONE

MODEL SET NAME: 2

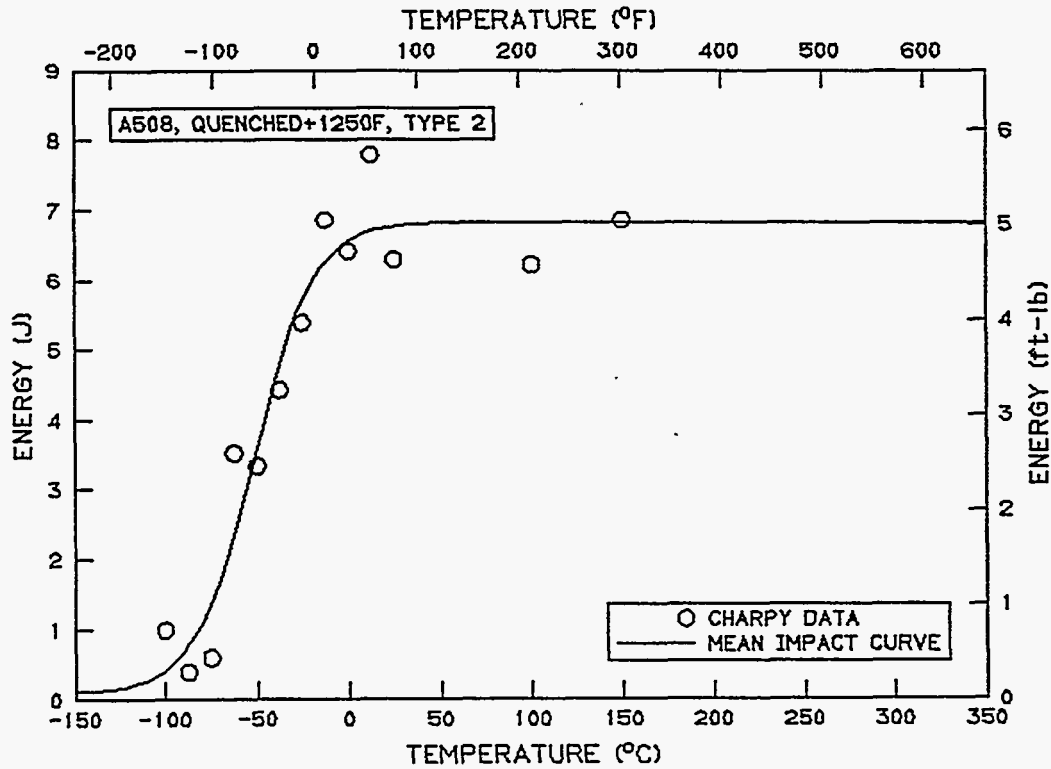

SOURCE: A5081250.T2 ANALYSIS SET

Y VARIABLE: EXPANSION

MODEL PARAMETERS

LOWER SHELF EXPANSION [HELD FIXED]: 0.000 (MM), 0.0000 (IN)

MID-TRANSITION TEMPERATURE: -41.4 (DEG C), -42.6 (DEG F)

TRANSITION ZONE WIDTH: 58.6 (C DEG), 105.5 (F DEG)

UPPER SHELF EXPANSION: 0.474 (MM), 0.0187 (IN)

UPPER SHELF EXPANSION: 0.474 (MM), 0.0187 (IN)

NOTE: NONE

MODEL SET NAME: 1

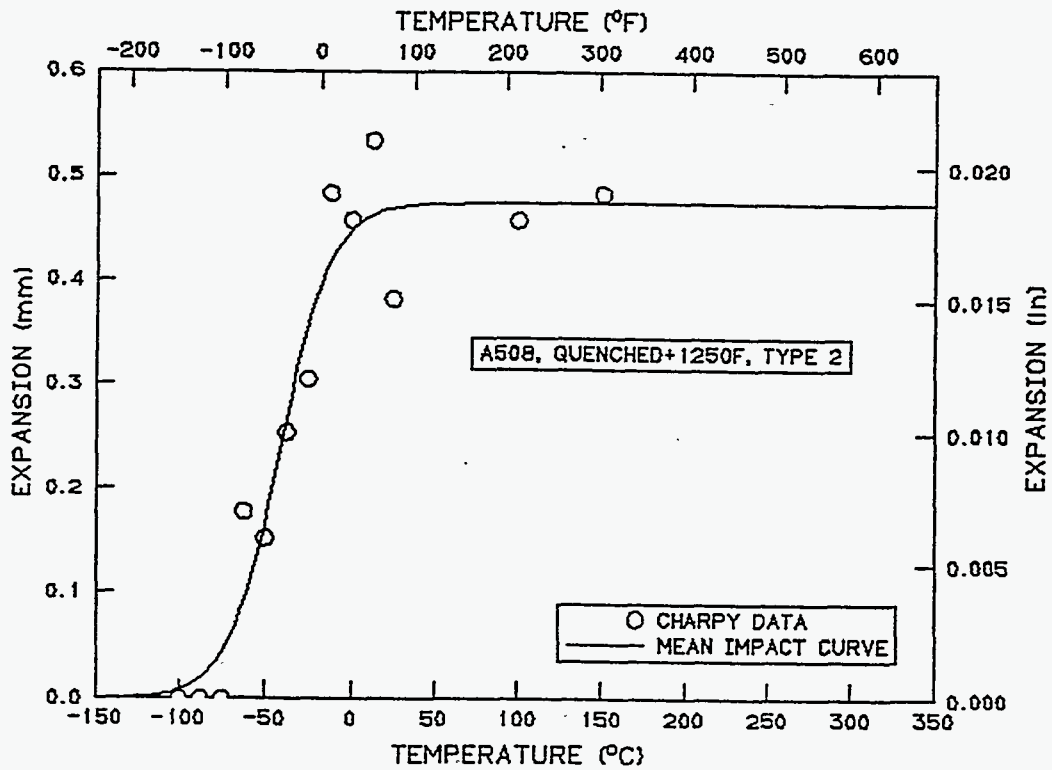

SOURCE: A5081250.T2 ANALYSIS SET

Y VARIABLE: SHEAR

MODEL PARAMETERS

LOWER SHELF SHEAR [HELD FIXED]: 0 (PERCENT)

MID-TRANSITION TEMPERATURE:-27.2 (DEG C),-16.9 (DEG F)

TRANSITION ZONE WIDTH: 20.2 (C DEG),36.3 (F DEG)

UPPER SHELF SHEAR [HELD FIXED]: 100 (PERCENT)

UPPER SHELF SHEAR: 100 (PERCENT)

TEMPERATURE [50 (PERCENT),50 (PERCENT) SHEAR]:-27.2 (DEG C),-16.9 (DEG F)

NOTE: NONE

MODEL SET NAME: 21

DESTINATION FILE NAME: 10

DESTINATION DIRECTORY PATH: C:\USER\

FILE NAME: 21

MODEL VARIABLES SAVED

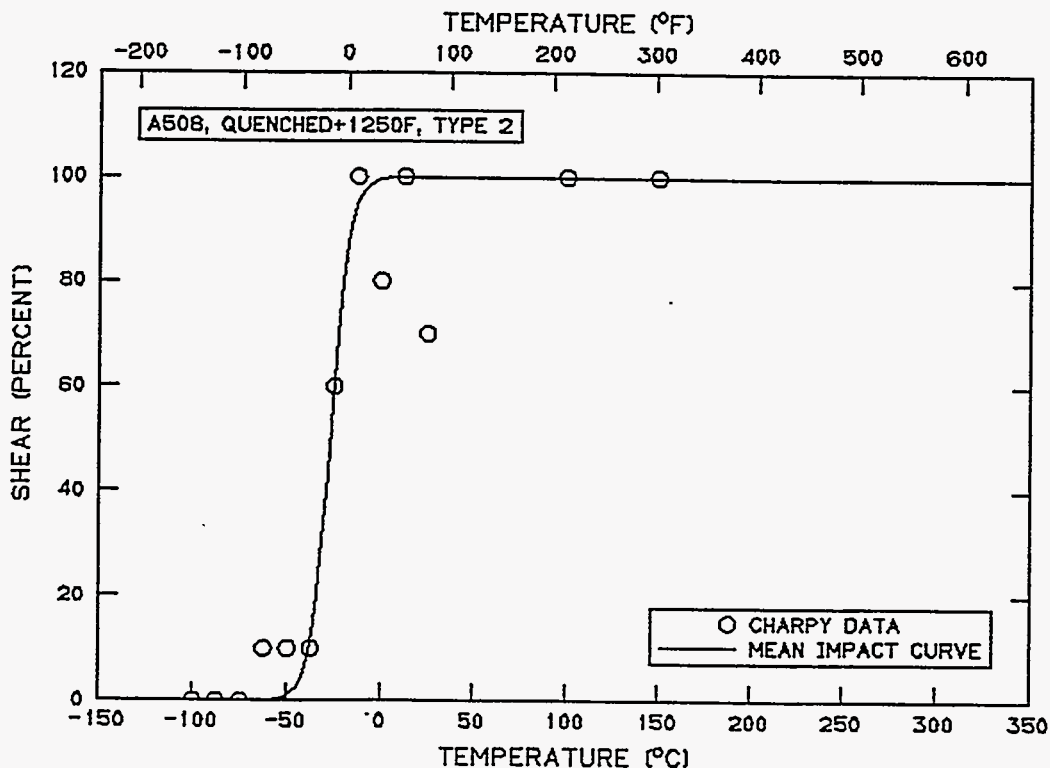

SOURCE: ANALYSIS SET
ANALYSIS SET NAME: A5081250.T3

SET NAME: A5081250.T3
NOTE: A508 QUENCHED+1250F, SPECIMEN TYPE 3

IDENT	TEMPERATURE		ENERGY		EXPANSION		SHEAR (PERCENT)
	(DEG C)	(DEG F)	(J)	(FT-LB)	(MM)	(IN)	
513D	-125.0	-193.0	0.68	0.50	0.00	0.000	0.0
513C	-100.0	-148.0	2.44	1.80	0.00	0.000	0.0
515A	-87.5	-125.5	6.78	5.00	0.15	0.006	0.0
517B	-87.5	-125.5	2.71	2.00	0.00	0.000	0.0
515B	-75.0	-103.0	5.97	4.40	0.15	0.006	5.0
515C	-62.5	-80.5	6.78	5.00	0.25	0.010	5.0
515D	-50.0	-58.0	9.90	7.30	0.38	0.015	5.0
517A	-37.5	-35.5	8.95	6.60	0.38	0.015	5.0
511A	-25.0	-13.0	11.39	8.40	0.48	0.019	35.0
513B	0.0	32.0	12.34	9.10	0.56	0.022	40.0
513A	25.0	77.0	12.88	9.50	0.61	0.024	70.0
511D	50.0	122.0	15.32	11.30	0.66	0.026	100.0
511B	100.0	212.0	17.63	13.00	0.79	0.031	100.0
517C	150.0	302.0	16.27	12.00	0.86	0.034	100.0
511C	200.0	392.0	18.30	13.50	0.86	0.034	100.0

NUMBER OF SPECIMENS: 15

SOURCE: A5081250.T3 ANALYSIS SET

Y VARIABLE: ENERGY

MODEL PARAMETERS

LOWER SHELF ENERGY [HELD FIXED]: 0.1 (J), 0.1 (FT-LB)

MID-TRANSITION TEMPERATURE: -44.2 (DEG C), -47.5 (DEG F)

TRANSITION ZONE WIDTH: 165.3 (C DEG), 297.6 (F DEG)

UPPER SHELF ENERGY: 17.2 (J), 12.7 (FT-LB)

UPPER SHELF ENERGY: 17.2 (J), 12.7 (FT-LB)

NOTE: NONE

MODEL SET NAME: 3

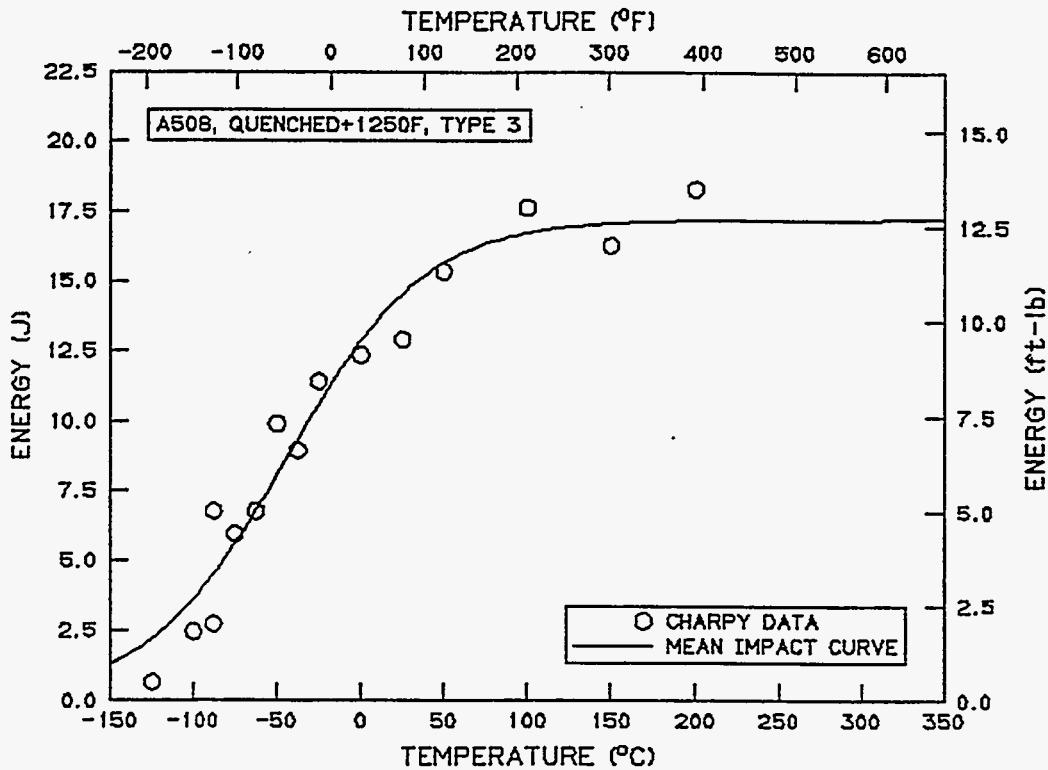

SOURCE: A5081250.T3 ANALYSIS SET

Y VARIABLE: EXPANSION

MODEL PARAMETERS

LOWER SHELF EXPANSION [HELD FIXED]: 0.000 (MM), 0.0000 (IN)

MID-TRANSITION TEMPERATURE: -29.3 (DEG C), -20.7 (DEG F)

TRANSITION ZONE WIDTH: 136.3 (C DEG), 245.3 (F DEG)

UPPER SHELF EXPANSION: 0.815 (MM), 0.0321 (IN)

UPPER SHELF EXPANSION: 0.815 (MM), 0.0321 (IN)

NOTE: NONE

MODEL SET NAME: 4

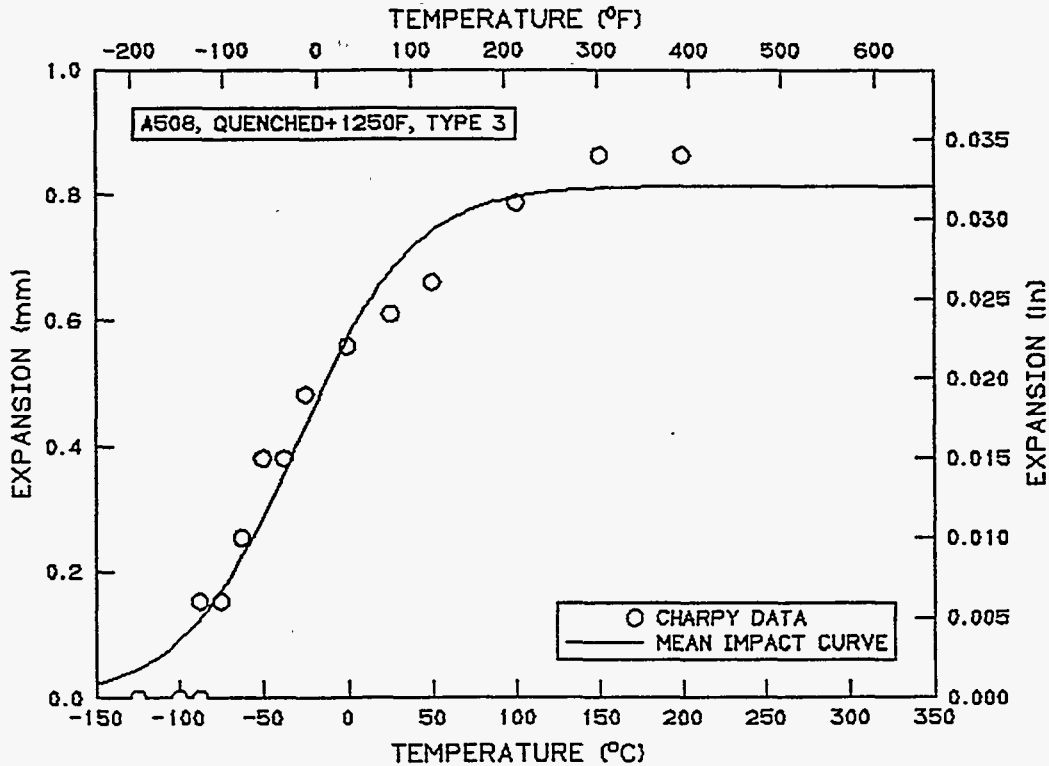

SOURCE: A5081250.T3 ANALYSIS SET

Y VARIABLE: SHEAR

MODEL PARAMETERS

LOWER SHELF SHEAR [HELD FIXED]: 0 (PERCENT)

MID-TRANSITION TEMPERATURE: 3.2 (DEG C), 37.8 (DEG F)

TRANSITION ZONE WIDTH: 83.6 (C DEG), 150.5 (F DEG)

UPPER SHELF SHEAR [HELD FIXED]: 100 (PERCENT)

UPPER SHELF SHEAR: 100 (PERCENT)

TEMPERATURE [50 (PERCENT), 50 (PERCENT) SHEAR]: 3.2 (DEG C), 37.8 (DEG F)

NOTE: NONE

MODEL SET NAME: 5

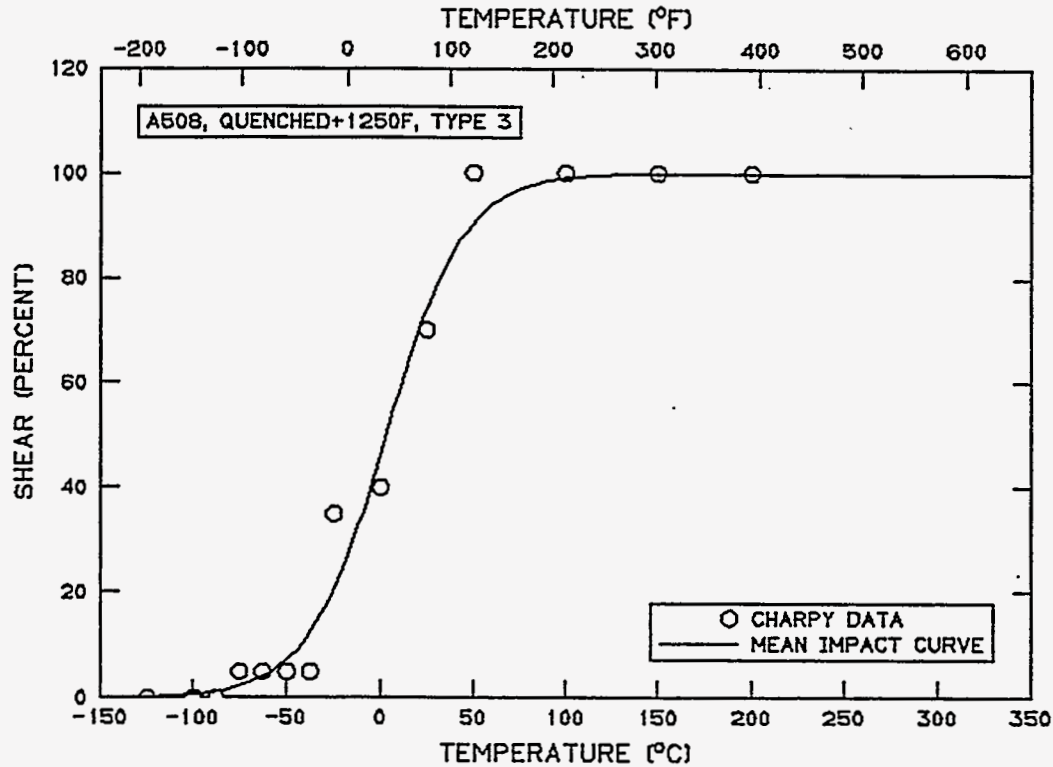

SOURCE: ANALYSIS SET
 ANALYSIS SET NAMES: TSP125T4 AND TSP125T4.FUL

SET NAME: TSP125T4
 NOTE: SUB-SIZE CORRELATION PROG., TSP 1250 DEG. F/4 Hours, TYPE 4

IDENT	TEMPERATURE		ENERGY (J)	EXPANSION		SHEAR (PERCENT)	
	(DEG C)	(DEG F)		(MM)	(IN)		
57E	-75.0	-103.0	1.13	0.83	0.00	0.000	0.0
57F	-62.5	-80.5	0.39	0.29	0.00	0.000	0.0
57D	-50.0	-58.0	1.19	0.88	0.00	0.000	0.0
511A	-37.5	-35.5	3.88	2.86	0.30	0.012	30.0
57C	-25.0	-13.0	3.69	2.72	0.36	0.014	70.0
511B	-12.5	9.5	4.08	3.01	0.33	0.013	40.0
57b	0.0	32.0	3.62	2.67	0.28	0.011	40.0
511C	12.5	54.5	6.59	4.86	0.53	0.021	100.0
57A	25.0	77.0	6.78	5.00	0.61	0.024	100.0
511D	37.5	99.5	6.26	4.62	0.53	0.021	100.0
511E	50.0	122.0	6.33	4.67	0.56	0.022	100.0
511F	100.0	212.0	5.95	4.39	0.46	0.018	100.0
515A	200.0	392.0	5.88	4.34	0.56	0.022	100.0

NUMBER OF SPECIMENS: 13

SET NAME: TSP125T4.FUL
 NOTE: NONE

IDENT	TEMPERATURE		ENERGY (J)	EXPANSION		SHEAR (PERCENT)	
	(DEG C)	(DEG F)		(MM)	(IN)		
515D	-50.0	-58.0	0.90	0.66	0.00	0.000	0.0
515C	-25.0	-13.0	1.70	1.25	0.03	0.001	0.0
515E	-12.5	9.5	0.30	0.22	0.00	0.000	0.0
515B	50.0	122.0	6.40	4.72	0.58	0.023	100.0
515F	100.0	212.0	6.40	4.72	0.51	0.020	100.0

NUMBER OF SPECIMENS: 5

SOURCE: TSP125T4 AND TSP125T4.FUL ANALYSIS SETS

Y VARIABLE: ENERGY

MODEL PARAMETERS

LOWER SHELF ENERGY [HELD FIXED]: 0.1 (J), 0.1 (FT-LB)

MID-TRANSITION TEMPERATURE: -15.2 (DEG C), 4.7 (DEG F)

TRANSITION ZONE WIDTH: 86.1 (C DEG), 154.9 (F DEG)

UPPER SHELF ENERGY: 6.5 (J), 4.8 (FT-LB)

UPPER SHELF ENERGY: 6.5 (J), 4.8 (FT-LB)

NOTE: A508, QUENCHED+1250F, TYPE 4, 2.25 AND 5.5 M/S

MODEL SET NAME: 1

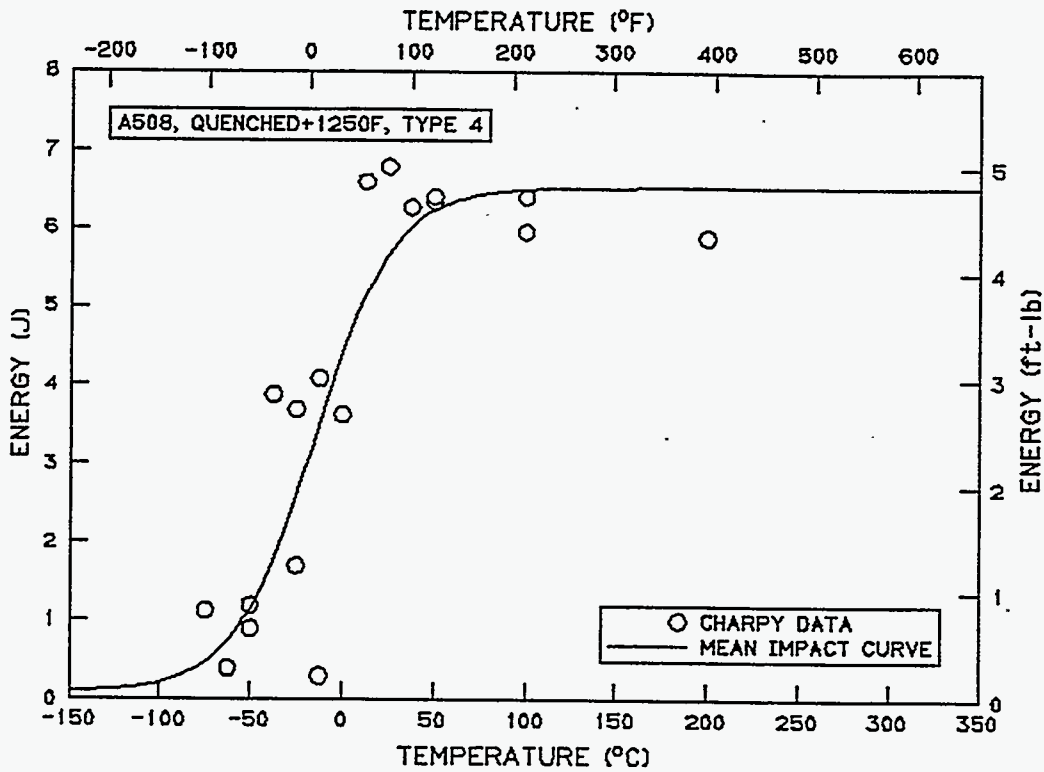

SOURCE: TSP125T4 AND TSP125T4.FUL ANALYSIS SETS

Y VARIABLE: EXPANSION

MODEL PARAMETERS

LOWER SHELF EXPANSION [HELD FIXED]: 0.000 (MM), 0.0000 (IN)

MID-TRANSITION TEMPERATURE: -9.6 (DEG C), 14.7 (DEG F)

TRANSITION ZONE WIDTH: 64.9 (C DEG), 116.7 (F DEG)

UPPER SHELF EXPANSION: 0.557 (MM), 0.0219 (IN)

UPPER SHELF EXPANSION: 0.557 (MM), 0.0219 (IN)

NOTE: NONE

MODEL SET NAME: 2

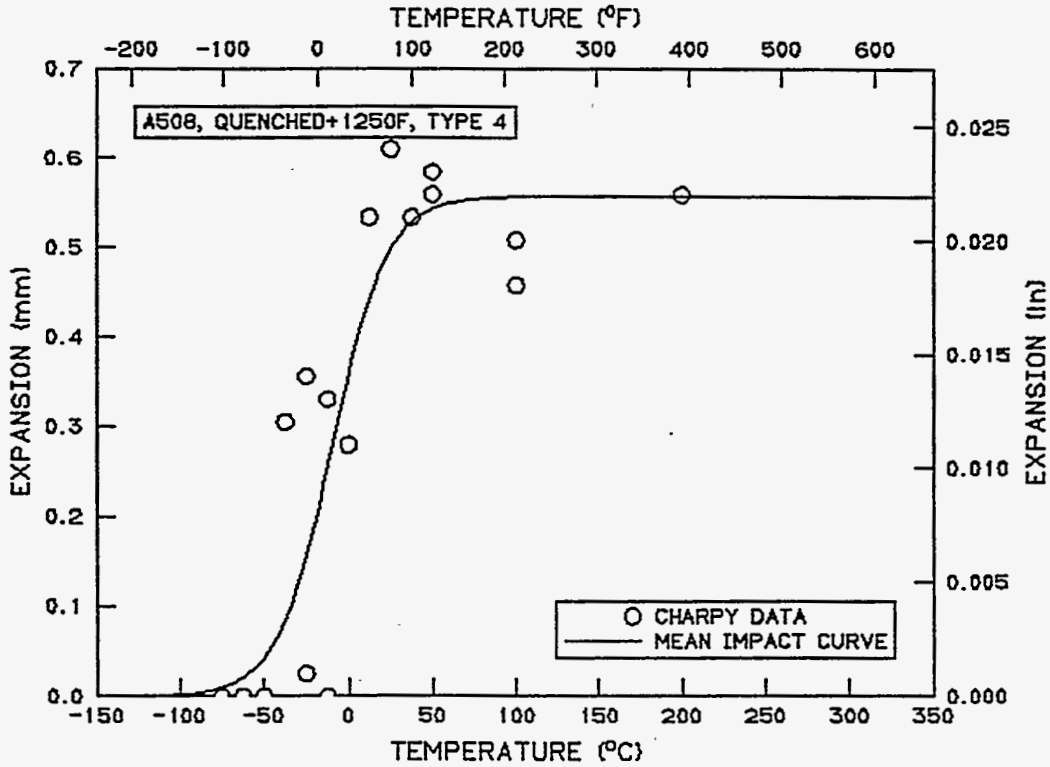

SOURCE: TSP125T4 AND TSP125T4.FUL ANALYSIS SETS

Y VARIABLE: SHEAR

MODEL PARAMETERS

LOWER SHELF SHEAR [HELD FIXED]: 0 (PERCENT)

MID-TRANSITION TEMPERATURE:-4.4 (DEG C),24.1 (DEG F)

TRANSITION ZONE WIDTH: 54.7 (C DEG),98.5 (F DEG)

UPPER SHELF SHEAR [HELD FIXED]: 100 (PERCENT)

UPPER SHELF SHEAR: 100 (PERCENT)

TEMPERATURE [50 (PERCENT),50 (PERCENT) SHEAR]:-4.4 (DEG C),24.1 (DEG F)

NOTE: NONE

MODEL SET NAME: 3

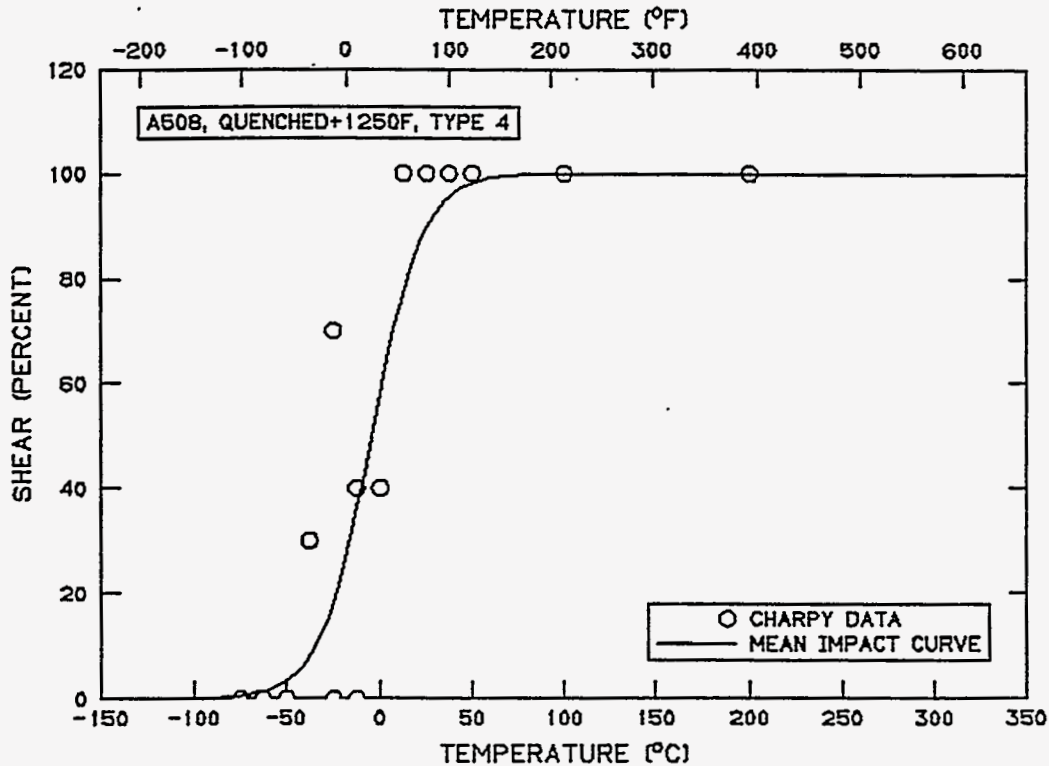

APPENDIX F

A 508, QUENCHED AND TEMPERED AT 704°C

SOURCE: ANALYSIS SET
ANALYSIS SET NAME: 508_1300.F

SET NAME: 508_1300.F
NOTE: A508, QUENCHED & TEMPERED @ 1300 F

IDENT	TEMPERATURE		ENERGY		EXPANSION		SHEAR (PERCENT)
	(DEG C)	(DEG F)	(J)	(FT-LB)	(MM)	(IN)	
6SC-20	-46.0	-50.8	29.00	21.39	0.38	0.015	0.0
6SC-18	-18.0	-0.4	68.00	50.15	0.99	0.039	15.0
6SC-10	-18.0	-0.4	58.00	42.78	0.58	0.023	5.0
6SC-16	4.4	39.9	58.00	42.78	0.84	0.033	25.0
6SC-22	16.0	60.8	100.00	73.76	1.37	0.054	40.0
6SC-8	23.0	73.4	106.00	78.18	1.50	0.059	50.0
6SC-12	66.0	150.8	152.00	112.11	2.06	0.081	100.0
6SC-14	121.0	249.8	153.00	112.85	1.92	0.076	100.0

NUMBER OF SPECIMENS: 8

ANALYSIS SET: 508_1300.F

Y VARIABLE: ENERGY

MODEL PARAMETERS

LOWER SHELF ENERGY [HELD FIXED]: 2.7 (J), 2.0 (FT-LB)

MID-TRANSITION TEMPERATURE: 5.7 (DEG C), 42.2 (DEG F)

TRANSITION ZONE WIDTH: 129.5 (C DEG), 233.1 (F DEG)

UPPER SHELF ENERGY: 163.5 (J), 120.6 (FT-LB)

UPPER SHELF ENERGY: 163.5 (J), 120.6 (FT-LB)

TEMPERATURE [41 (J), 30.2 (FT-LB) ENERGY]: -32.0 (DEG C), -25.6 (DEG F)

TEMPERATURE [68 (J), 50.2 (FT-LB) ENERGY]: -6.6 (DEG C), 20.0 (DEG F)

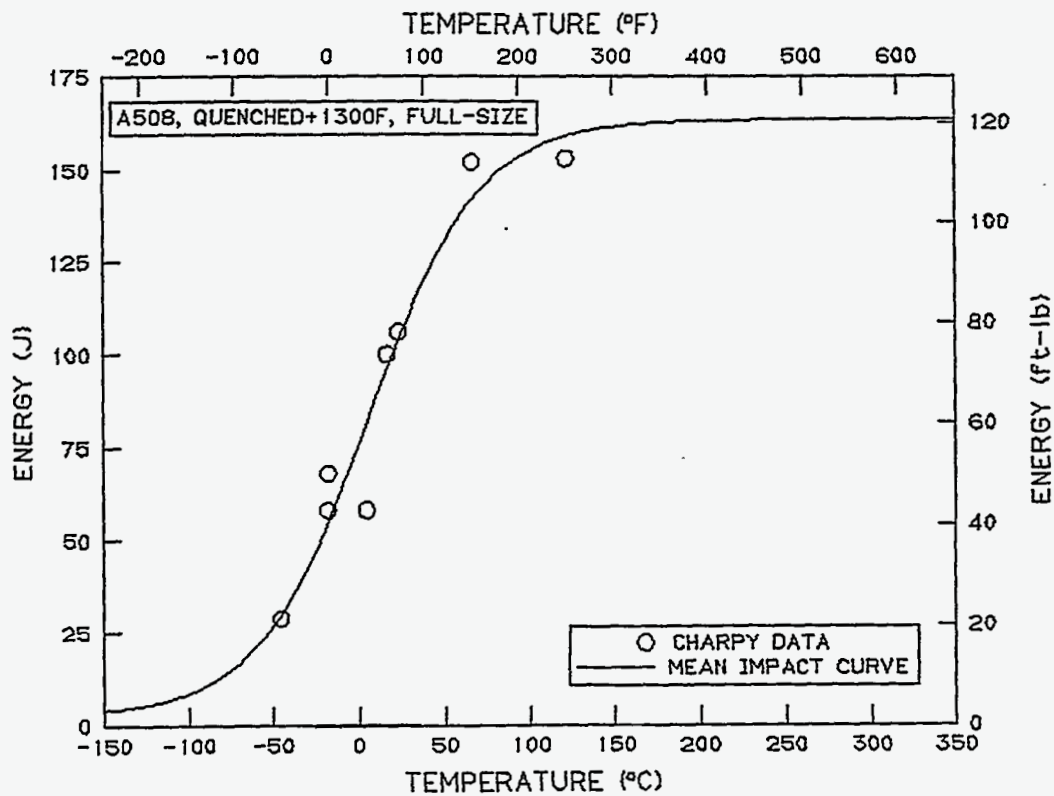

NOTE: A508, QUENCHED & TEMPERED @ 1300 F, FULL-SIZE
MODEL SET NAME: 508_1300.F

ANALYSIS SET: 508_1300.F

Y VARIABLE: EXPANSION

MODEL PARAMETERS

LOWER SHELF EXPANSION [HELD FIXED]: 0.061 (MM), 0.0024 (IN)

MID-TRANSITION TEMPERATURE: 1.5 (DEG C), 34.8 (DEG F)

TRANSITION ZONE WIDTH: 106.6 (C DEG), 191.9 (F DEG)

UPPER SHELF EXPANSION: 2.064 (MM), 0.0812 (IN)

UPPER SHELF EXPANSION: 2.064 (MM), 0.0812 (IN)

TEMPERATURE [0.89 (MM), 0.035 (IN) EXPANSION]: -7.7 (DEG C), 18.1 (DEG F)

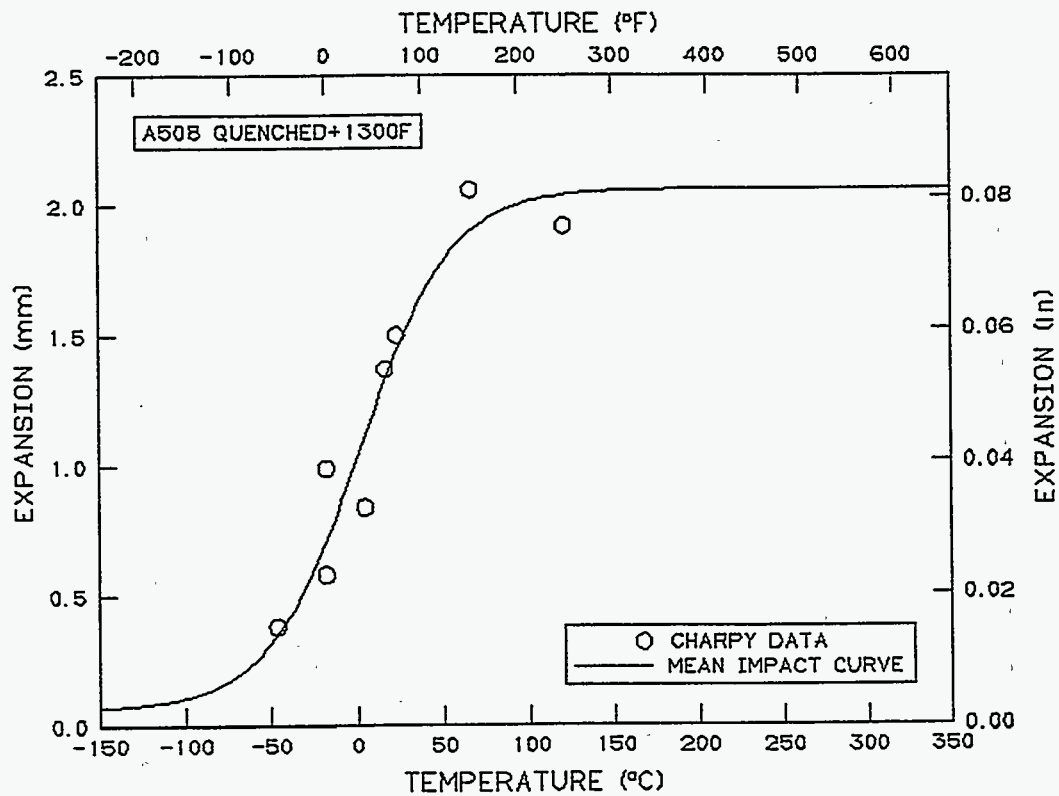

NOTE: A508, QUENCHED+1300F, FULL-SIZE
MODEL SET NAME: 508_1300.FE

DATA SOURCE: ANALYSIS SET

ANALYSIS SET: 508_1300.F

Y VARIABLE: SHEAR

MODEL PARAMETERS

LOWER SHELF SHEAR [HELD FIXED]: 0 (PERCENT)

MID-TRANSITION TEMPERATURE: 21.8 (DEG C), 71.2 (DEG F)

TRANSITION ZONE WIDTH: 62.8 (C DEG), 113 (F DEG)

UPPER SHELF SHEAR [HELD FIXED]: 100 (PERCENT)

UPPER SHELF SHEAR: 100 (PERCENT)

TEMPERATURE [50 (PERCENT), 50 (PERCENT) SHEAR]: 21.8 (DEG C), 71.2 (DEG F)

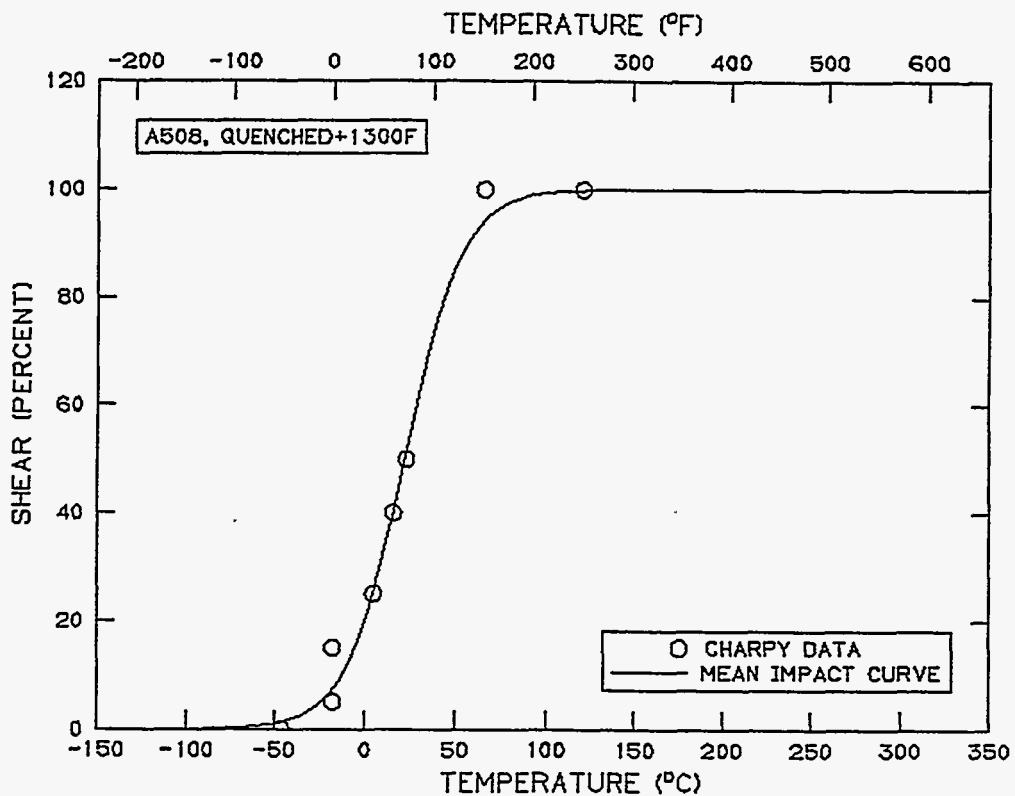

REMARK: A508, QUENCHED+1300F, FULL-SIZE
MODEL SET NAME: 508_1300.FS

SOURCE: ANALYSIS SET
ANALYSIS SET NAME: A5081300.T1

SET NAME: A5081300.T1
NOTE: A508 QUENCHED+1300F, TYPE 1 SPEC.

IDENT	TEMPERATURE (DEG C) (DEG F)		ENERGY (J) (FT-LB)		EXPANSION (MM) (IN)		SHEAR (PERCENT)
611C	-137.5	-215.5	0.46	0.34	0.00	0.000	0.0
611B	-125.0	-193.0	1.84	1.36	0.00	0.000	0.0
611D	-112.5	-170.5	4.77	3.52	0.08	0.003	0.0
611A	-100.0	-148.0	5.84	4.31	0.13	0.005	0.0
616A	-87.5	-125.5	2.05	1.51	0.00	0.000	0.0
69D	-75.0	-103.0	8.13	6.00	0.20	0.008	0.0
616B	-62.5	-80.5	27.01	19.92	0.89	0.035	50.0
616C	-50.0	-58.0	23.92	17.64	1.04	0.041	50.0
616D	-37.5	-35.5	3.61	2.66	0.23	0.009	10.0
620D	-37.5	-35.5	19.25	14.20	0.76	0.030	45.0
69C	-25.0	-13.0	36.28	26.76	1.02	0.040	100.0
620A	-12.5	9.5	34.49	25.44	1.02	0.040	100.0
69B	0.0	32.0	33.90	25.00	0.99	0.039	100.0
69A	25.0	77.0	37.65	27.77	0.91	0.036	100.0
620C	75.0	167.0	36.74	27.10	0.97	0.038	100.0
620B	150.0	302.0	34.25	25.26	0.91	0.036	100.0

NUMBER OF SPECIMENS: 16

SOURCE: A5081300.T1 ANALYSIS SET

Y VARIABLE: ENERGY

MODEL PARAMETERS

LOWER SHELF ENERGY [HELD FIXED]: 0.1 (J), 0.1 (FT-LB)

MID-TRANSITION TEMPERATURE: -50.9 (DEG C), -59.5 (DEG F)

TRANSITION ZONE WIDTH: 101.5 (C DEG), 182.6 (F DEG)

UPPER SHELF ENERGY: 37.3 (J), 27.5 (FT-LB)

UPPER SHELF ENERGY: 37.3 (J), 27.5 (FT-LB)

NOTE: A508, QUENCHED+1300F, TYPE 1

MODEL SET NAME: 4

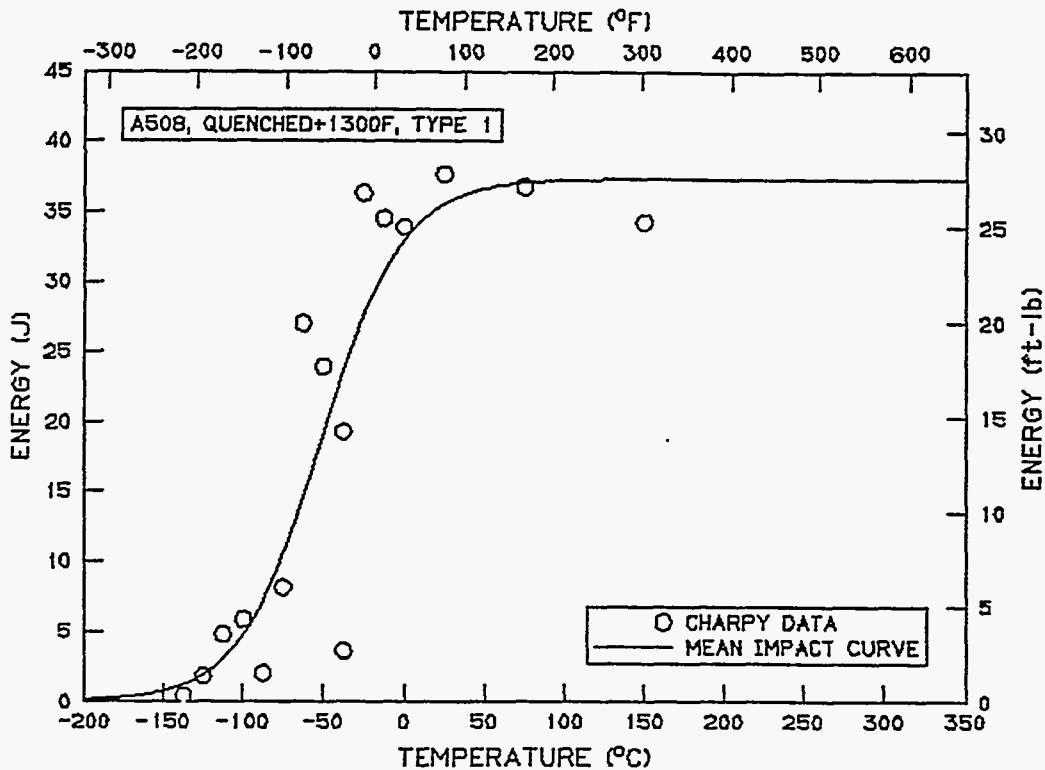

SOURCE: A5081300.T1 ANALYSIS SET

Y VARIABLE: EXPANSION
TANH REGRESSION DIVERGING
TANH REGRESSION DIVERGING
MODEL PARAMETERS

LOWER SHELF EXPANSION [HELD FIXED]: 0.000 (MM), 0.0000 (IN)
MID-TRANSITION TEMPERATURE: -70.8 (DEG C), -95.4 (DEG F)
TRANSITION ZONE WIDTH: 12.9 (C DEG), 23.2 (F DEG)
UPPER SHELF EXPANSION [HELD FIXED]: 0.960 (MM), 0.0378 (IN)
NOTE: A508, QUENCHED+1300F, TYPE 1
MODEL SET NAME: 5

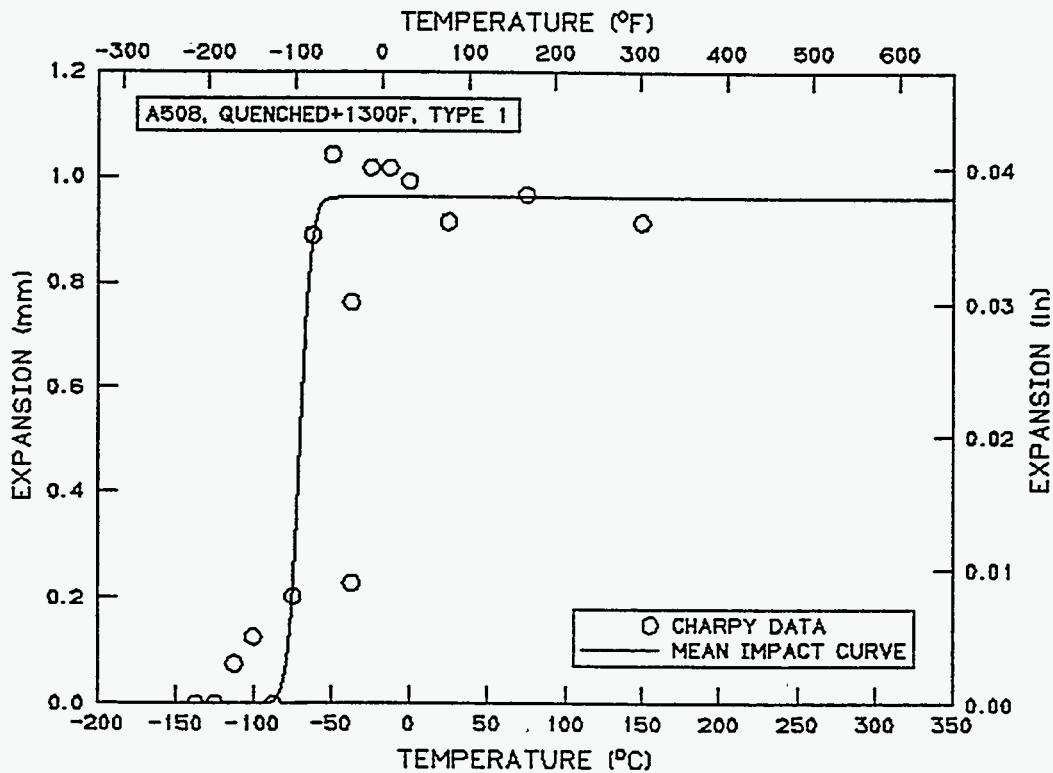

SOURCE: A5081300.T1 ANALYSIS SET

Y VARIABLE: SHEAR

MODEL PARAMETERS

LOWER SHELF SHEAR [HELD FIXED]: 0 (PERCENT)

MID-TRANSITION TEMPERATURE:-41.0 (DEG C),-41.8 (DEG F)

TRANSITION ZONE WIDTH: 60.9 (C DEG),109.7 (F DEG)

UPPER SHELF SHEAR [HELD FIXED]: 100 (PERCENT)

UPPER SHELF SHEAR: 100 (PERCENT)

TEMPERATURE [50 (PERCENT),50 (PERCENT) SHEAR]:-41.0 (DEG C),-41.8 (DEG F)

NOTE: A508, QUENCHED+1300F, TYPE 1

MODEL SET NAME: 6

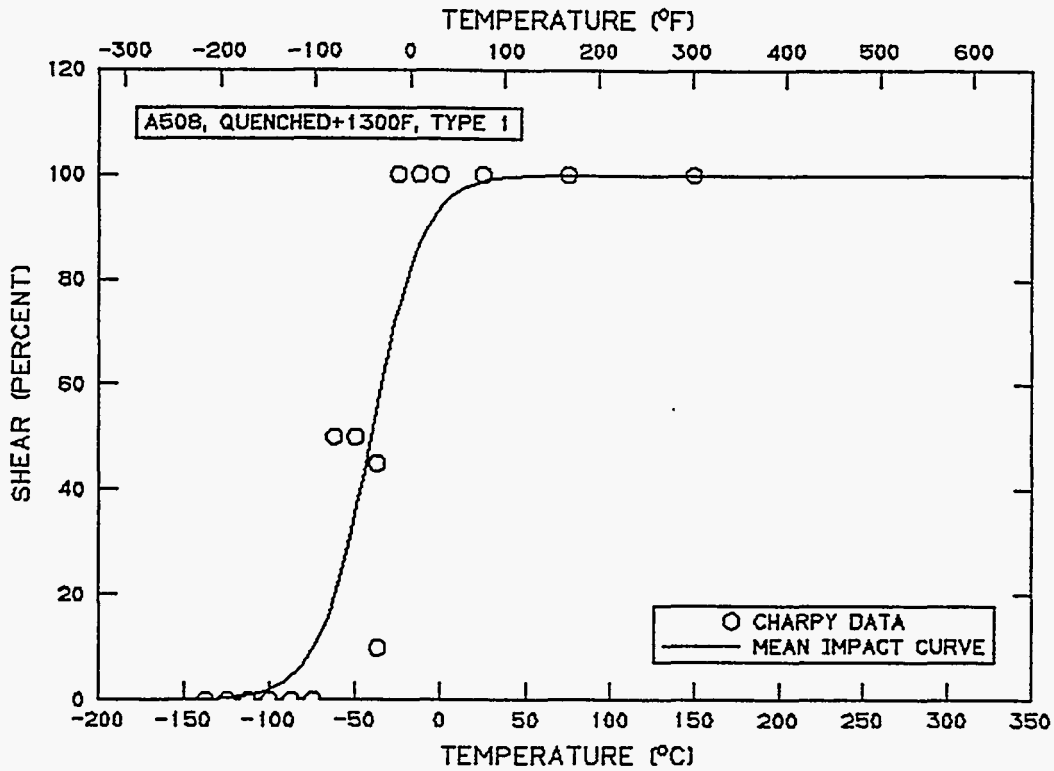

SOURCE: ANALYSIS SET
ANALYSIS SET NAME: A5081300.T2

SET NAME: A5081300.T2
NOTE: A508 QUENCHED+1300F, TYPE 2

IDENT	TEMPERATURE		ENERGY (J)	(FT-LB)	EXPANSION		SHEAR (PERCENT)
	(DEG C)	(DEG F)			(MM)	(IN)	
615B	-100.0	-148.0	0.39	0.29	0.00	0.000	0.0
615C	-87.5	-125.5	4.04	2.98	0.25	0.010	10.0
641B	-87.5	-125.5	0.26	0.19	0.00	0.000	0.0
615A	-75.0	-103.0	3.27	2.41	0.18	0.007	10.0
615D	-62.5	-80.5	3.71	2.74	0.23	0.009	10.0
611D	-50.0	-58.0	5.57	4.11	0.43	0.017	45.0
617A	-37.5	-35.5	6.47	4.77	0.38	0.015	45.0
611C	-25.0	-13.0	8.22	6.06	0.51	0.020	80.0
617B	-12.5	9.5	6.21	4.58	0.46	0.018	70.0
611B	0.0	32.0	9.03	6.66	0.69	0.027	100.0
617C	12.5	54.5	9.84	7.26	0.71	0.028	100.0
611A	25.0	77.0	8.53	6.29	0.58	0.023	100.0
617D	100.0	212.0	8.98	6.62	0.69	0.027	100.0
641A	150.0	302.0	9.65	7.12	0.66	0.026	100.0

NUMBER OF SPECIMENS: 14

SOURCE: A5081300.T2 ANALYSIS SET

Y VARIABLE: ENERGY

MODEL PARAMETERS

LOWER SHELF ENERGY [HELD FIXED]: 0.1 (J), 0.1 (FT-LB)

MID-TRANSITION TEMPERATURE: -56.3 (DEG C), -69.3 (DEG F)

TRANSITION ZONE WIDTH: 90.7 (C DEG), 163.2 (F DEG)

UPPER SHELF ENERGY: 9.3 (J), 6.8 (FT-LB)

UPPER SHELF ENERGY: 9.3 (J), 6.8 (FT-LB)

NOTE: A508, QUENCHED+1300F, TYPE 2

MODEL SET NAME: 9

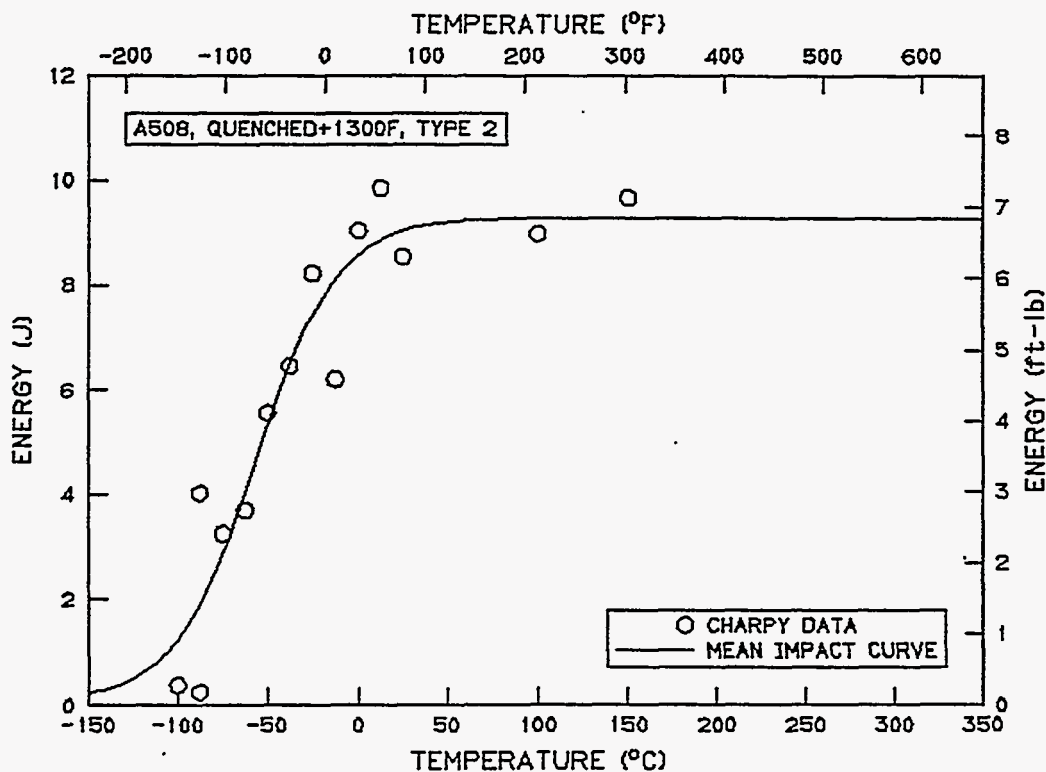

SOURCE: A5081300.T2 ANALYSIS SET

Y VARIABLE: EXPANSION

MODEL PARAMETERS

LOWER SHELF EXPANSION [HELD FIXED]: 0.000 (MM), 0.0000 (IN)

MID-TRANSITION TEMPERATURE: -50.6 (DEG C), -59.0 (DEG F)

TRANSITION ZONE WIDTH: 91.8 (C DEG), 165.2 (F DEG)

UPPER SHELF EXPANSION: 0.673 (MM), 0.0265 (IN)

UPPER SHELF EXPANSION: 0.673 (MM), 0.0265 (IN)

NOTE: A508, QUENCHED+1300F, TYPE 2

MODEL SET NAME: 8

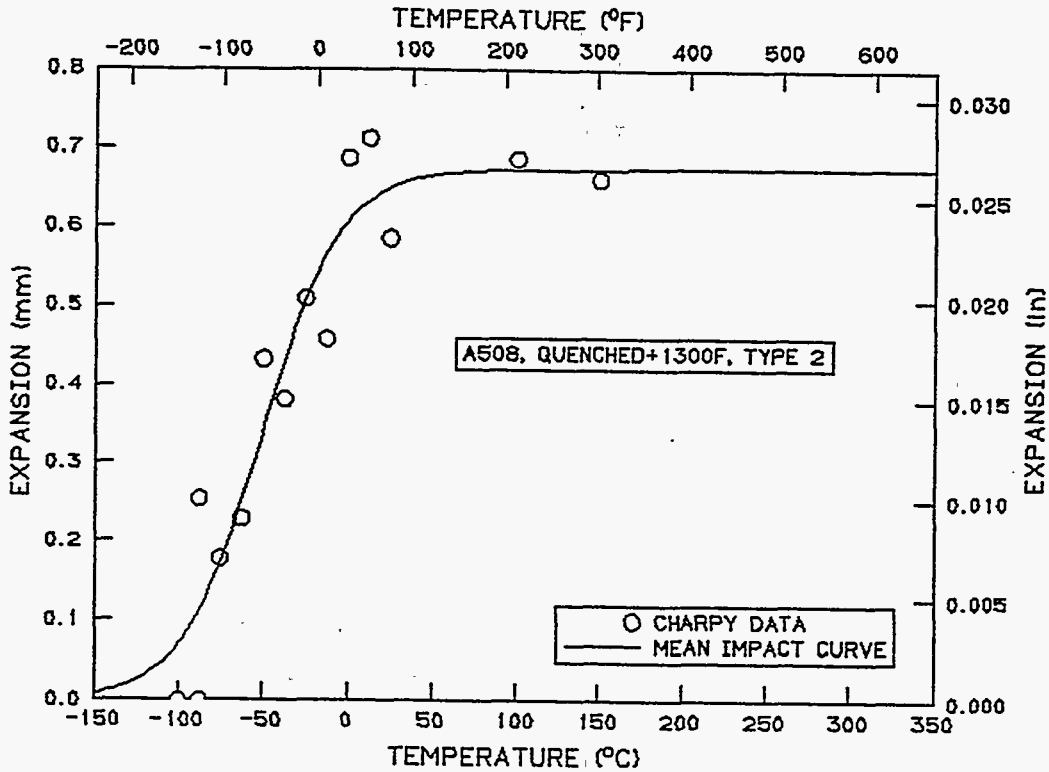

SOURCE: A5081300.T2 ANALYSIS SET

Y VARIABLE: SHEAR

MODEL PARAMETERS

LOWER SHELF SHEAR [HELD FIXED]: 0 (PERCENT)

MID-TRANSITION TEMPERATURE:-39.2 (DEG C),-38.6 (DEG F)

TRANSITION ZONE WIDTH: 62.7 (C DEG),112.9 (F DEG)

UPPER SHELF SHEAR [HELD FIXED]: 100 (PERCENT)

UPPER SHELF SHEAR: 100 (PERCENT)

TEMPERATURE [50 (PERCENT),50 (PERCENT) SHEAR]:-39.2 (DEG C),-38.6 (DEG F)

NOTE: A508, QUENCHED+1300F, TYPE 2

MODEL SET NAME: 7

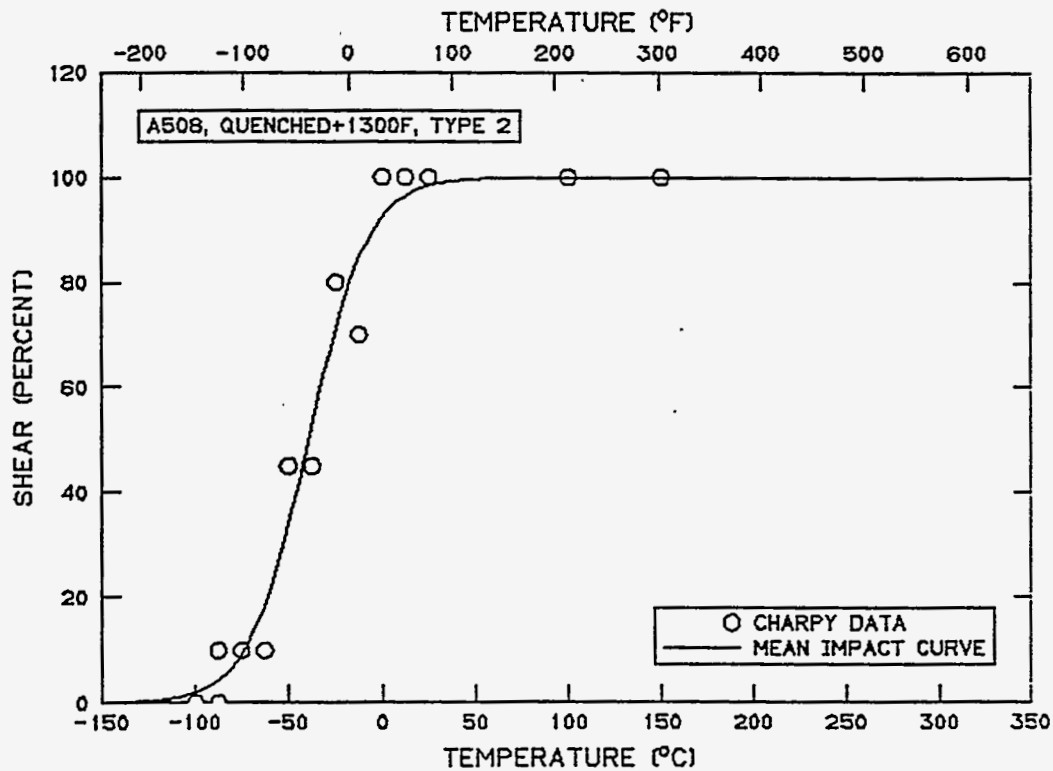

SOURCE: ANALYSIS SET
ANALYSIS SET NAME: A5081300.T3

SET NAME: A5081300.T3
NOTE: A508 QUENCHED+1300F, TYPE 3

IDENT	TEMPERATURE		ENERGY		EXPANSION		SHEAR
	(DEG C)	(DEG F)	(J)	(FT-LB)	(MM)	(IN)	(PERCENT)
613D	-125.0	-193.0	0.95	0.70	0.00	0.000	0.0
613C	-100.0	-148.0	3.12	2.30	0.00	0.000	0.0
613A	-87.5	-125.5	0.81	0.60	0.00	0.000	0.0
615A	-87.5	-125.5	9.76	7.20	0.43	0.017	10.0
613B	-75.0	-103.0	10.98	8.10	0.51	0.020	5.0
615B	-62.5	-80.5	12.47	9.20	0.66	0.026	15.0
615C	-50.0	-58.0	9.49	7.00	0.41	0.016	15.0
615D	-37.5	-35.5	11.80	8.70	0.61	0.024	20.0
617A	-25.0	-13.0	16.95	12.50	0.79	0.031	35.0
619B	0.0	32.0	24.95	18.40	0.91	0.036	100.0
617B	50.0	122.0	22.24	16.40	0.79	0.031	100.0
619A	50.0	122.0	23.59	17.40	0.89	0.035	100.0
617C	100.0	212.0	23.86	17.60	0.89	0.035	100.0
617D	200.0	392.0	25.22	18.60	0.89	0.035	100.0

NUMBER OF SPECIMENS: 14

SOURCE: A5081300.T3 ANALYSIS SET

Y VARIABLE: ENERGY

MODEL PARAMETERS

LOWER SHELF ENERGY [HELD FIXED]: 0.1 (J), 0.1 (FT-LB)

MID-TRANSITION TEMPERATURE: -50.3 (DEG C), -58.5 (DEG F)

TRANSITION ZONE WIDTH: 119.8 (C DEG), 215.6 (F DEG)

UPPER SHELF ENERGY: 24.6 (J), 18.2 (FT-LB)

UPPER SHELF ENERGY: 24.6 (J), 18.2 (FT-LB)

NOTE: A508, QUENCHED+1300F, TYPE 3

MODEL SET NAME: 0

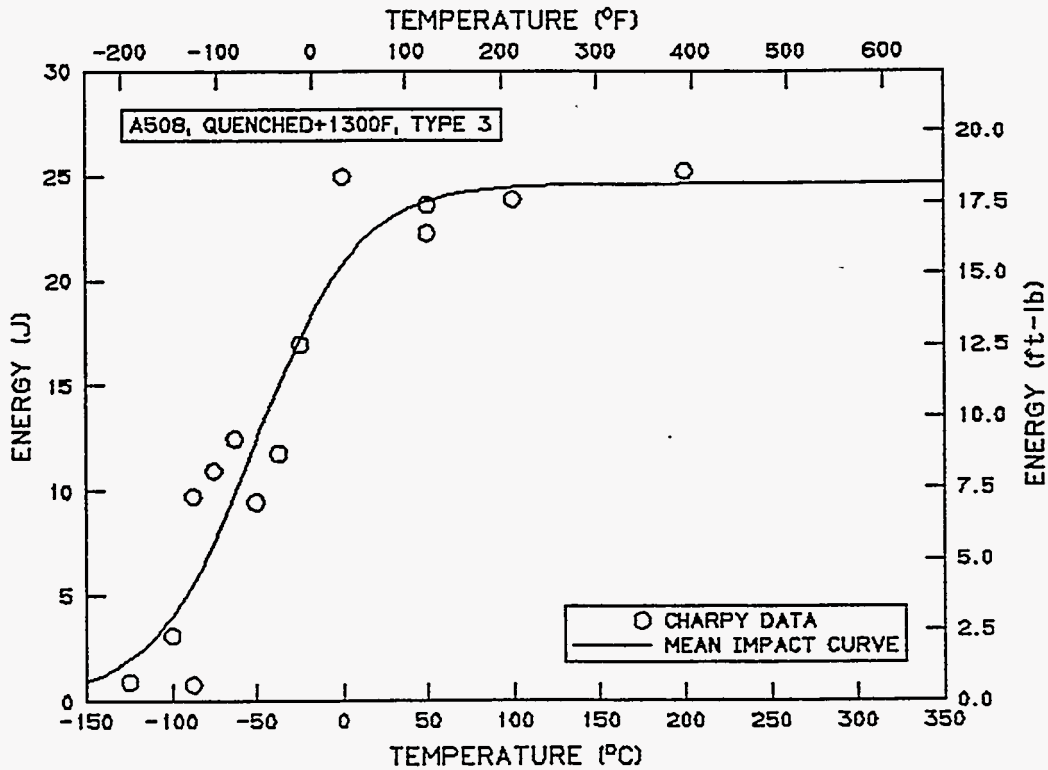

SOURCE: A5081300.T3 ANALYSIS SET

Y VARIABLE: EXPANSION

MODEL PARAMETERS

LOWER SHELF EXPANSION [HELD FIXED]: 0.000 (MM), 0.0000 (IN)

MID-TRANSITION TEMPERATURE: -67.1 (DEG C), -88.8 (DEG F)

TRANSITION ZONE WIDTH: 82.3 (C DEG), 148.1 (F DEG)

UPPER SHELF EXPANSION: 0.867 (MM), 0.0341 (IN)

UPPER SHELF EXPANSION: 0.867 (MM), 0.0341 (IN)

NOTE: A508, QUENCHED+1300F, TYPE 3

MODEL SET NAME: 1

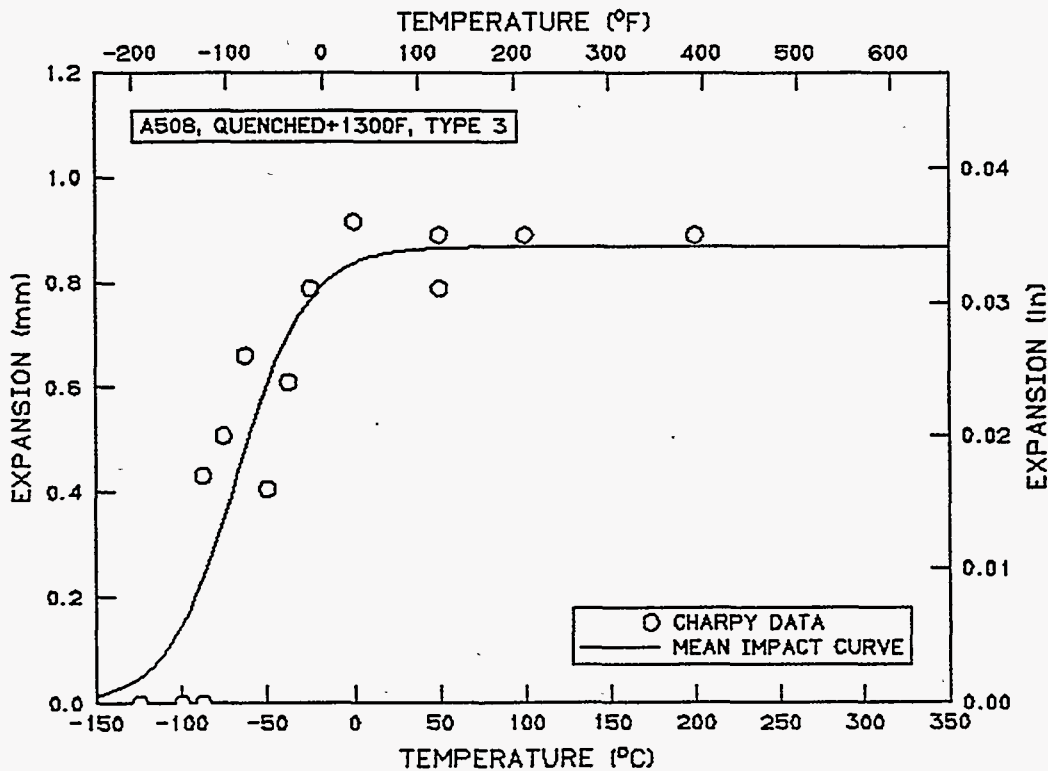

SOURCE: A5081300.T3 ANALYSIS SET

Y VARIABLE: SHEAR

MODEL PARAMETERS

LOWER SHELF SHEAR [HELD FIXED]: 0 (PERCENT)

MID-TRANSITION TEMPERATURE:-22.2 (DEG C),-7.9 (DEG F)

TRANSITION ZONE WIDTH: 42.8 (C DEG),77.1 (F DEG)

UPPER SHELF SHEAR [HELD FIXED]: 100 (PERCENT)

UPPER SHELF SHEAR: 100 (PERCENT)

TEMPERATURE [50 (PERCENT),50 (PERCENT) SHEAR]:-22.2 (DEG C),-7.9 (DEG F)

NOTE: A508, QUENCHED+1300F, TYPE 3

MODEL SET NAME: 2

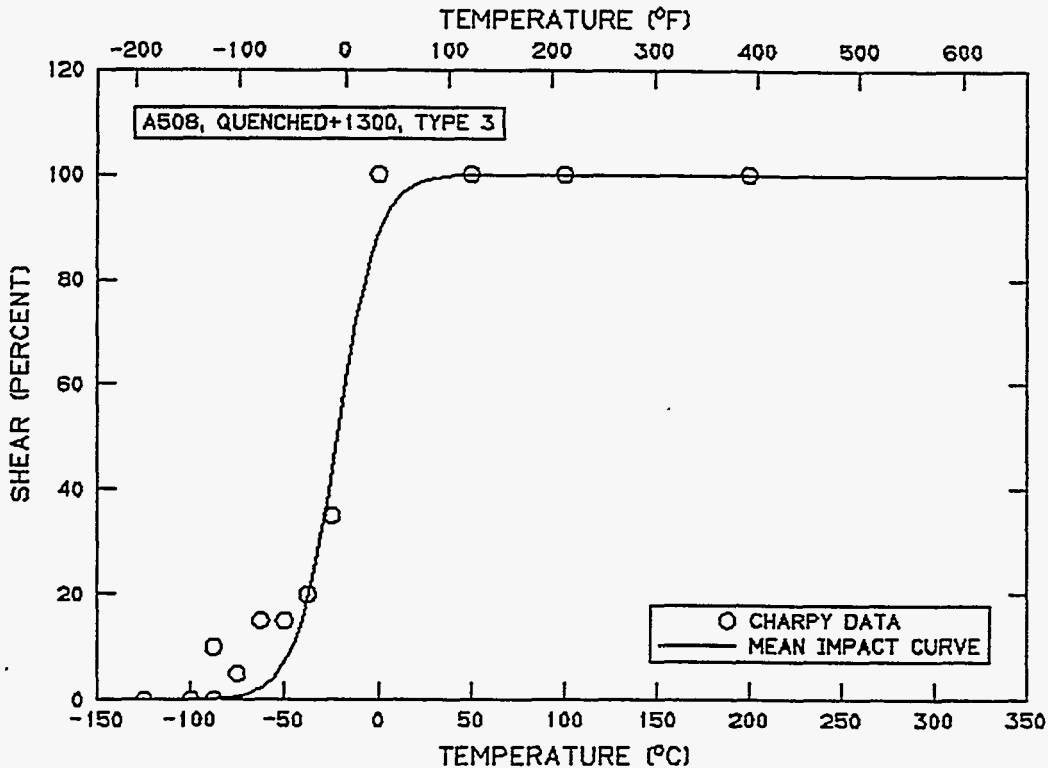

SOURCE: ANALYSIS SET
ANALYSIS SET NAME: A5081300.T4

SET NAME: A5081300.T4
NOTE: A508 QUENCHED+1300F, TYPE 4

IDENT	TEMPERATURE		ENERGY	EXPANSION		SHEAR	
	(DEG C)	(DEG F)	(J)	(FT-LB)	(MM)	(IN)	(PERCENT)
67F	-100.0	-148.0	0.27	0.20	0.00	0.000	0.0
619A	-87.5	-125.5	0.14	0.10	0.00	0.000	0.0
67E	-75.0	-103.0	2.18	1.61	0.13	0.005	5.0
619B	-62.5	-80.5	1.26	0.93	0.00	0.000	5.0
641A	-62.5	-80.5	0.60	0.44	0.00	0.000	0.0
67D	-50.0	-58.0	3.55	2.62	0.28	0.011	15.0
641B	-50.0	-58.0	1.33	0.98	0.05	0.002	10.0
619C	-37.5	-35.5	5.69	4.20	0.46	0.018	40.0
641C	-37.5	-35.5	4.20	3.10	0.33	0.013	30.0
67C	-25.0	-13.0	5.37	3.96	0.46	0.018	60.0
619D	-12.5	9.5	7.73	5.70	0.61	0.024	100.0
67B	0.0	32.0	7.66	5.65	0.61	0.024	100.0
67A	25.0	77.0	7.61	5.61	0.61	0.024	100.0
619E	100.0	212.0	6.97	5.14	0.66	0.026	100.0
619F	150.0	302.0	7.16	5.28	0.74	0.029	100.0

NUMBER OF SPECIMENS: 15

SOURCE: A5081300.T4 ANALYSIS SET

Y VARIABLE: ENERGY

MODEL PARAMETERS

LOWER SHELF ENERGY [HELD FIXED]: 0.1 (J), 0.1 (FT-LB)

MID-TRANSITION TEMPERATURE: -42.8 (DEG C), -45.1 (DEG F)

TRANSITION ZONE WIDTH: 46.0 (C DEG), 82.8 (F DEG)

UPPER SHELF ENERGY: 7.5 (J), 5.5 (FT-LB)

UPPER SHELF ENERGY: 7.5 (J), 5.5 (FT-LB)

NOTE: A508, QUENCHED+1300F, TYPE 4

MODEL SET NAME: 6

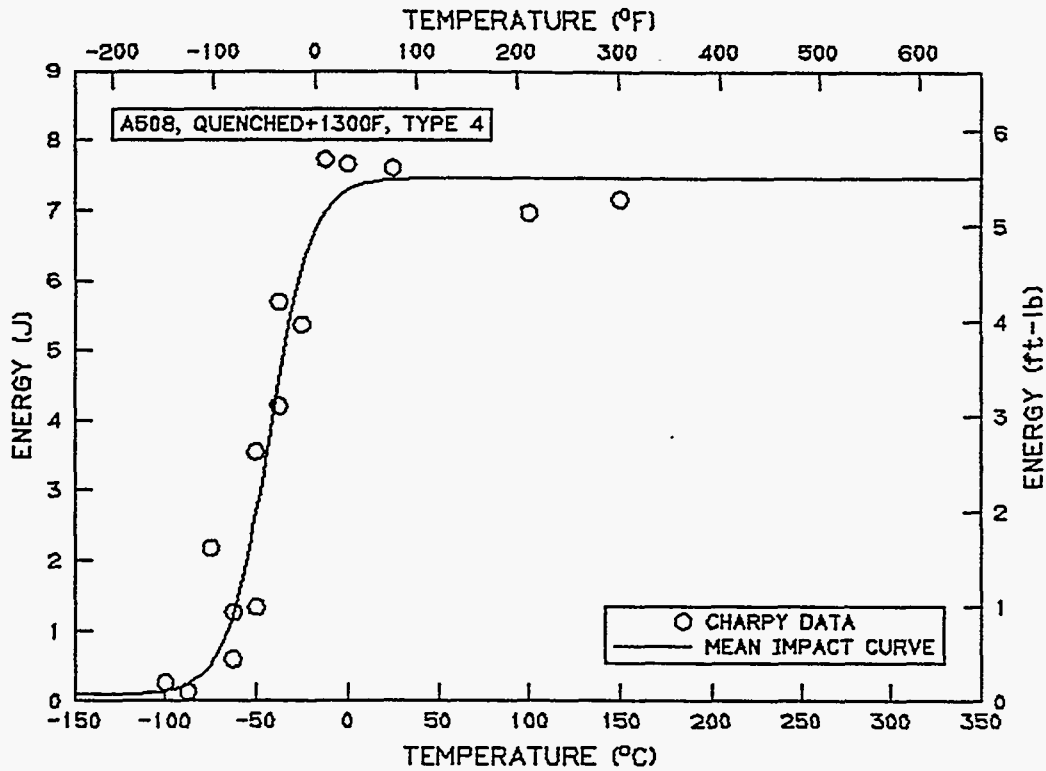

SOURCE: A5081300.T4 ANALYSIS SET

Y VARIABLE: EXPANSION

MODEL PARAMETERS

LOWER SHELF EXPANSION [HELD FIXED]: 0.000 (MM), 0.0000 (IN)

MID-TRANSITION TEMPERATURE: -39.2 (DEG C), -38.6 (DEG F)

TRANSITION ZONE WIDTH: 40.8 (C DEG), 73.4 (F DEG)

UPPER SHELF EXPANSION: 0.653 (MM), 0.0257 (IN)

UPPER SHELF EXPANSION: 0.653 (MM), 0.0257 (IN)

NOTE: A508, QUENCHED+1300F, TYPE 4

MODEL SET NAME: 5

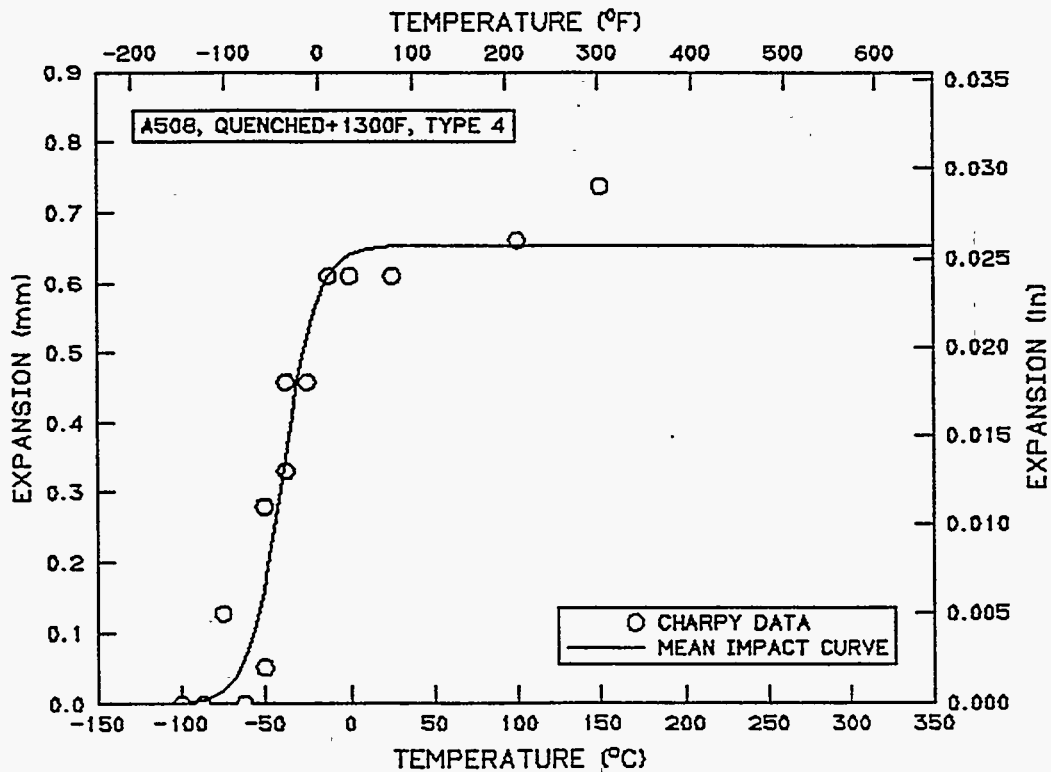

SOURCE: A5081300.T4 ANALYSIS SET

Y VARIABLE: SHEAR

MODEL PARAMETERS

LOWER SHELF SHEAR [HELD FIXED]: 0 (PERCENT)

MID-TRANSITION TEMPERATURE:-31.7 (DEG C),-25.0 (DEG F)

TRANSITION ZONE WIDTH: 35.2 (C DEG),63.4 (F DEG)

UPPER SHELF SHEAR [HELD FIXED]: 100 (PERCENT)

UPPER SHELF SHEAR: 100 (PERCENT)

TEMPERATURE [50 (PERCENT),50 (PERCENT) SHEAR]:-31.7 (DEG C),-25.0 (DEG F)

NOTE: NONE

MODEL SET NAME: 4

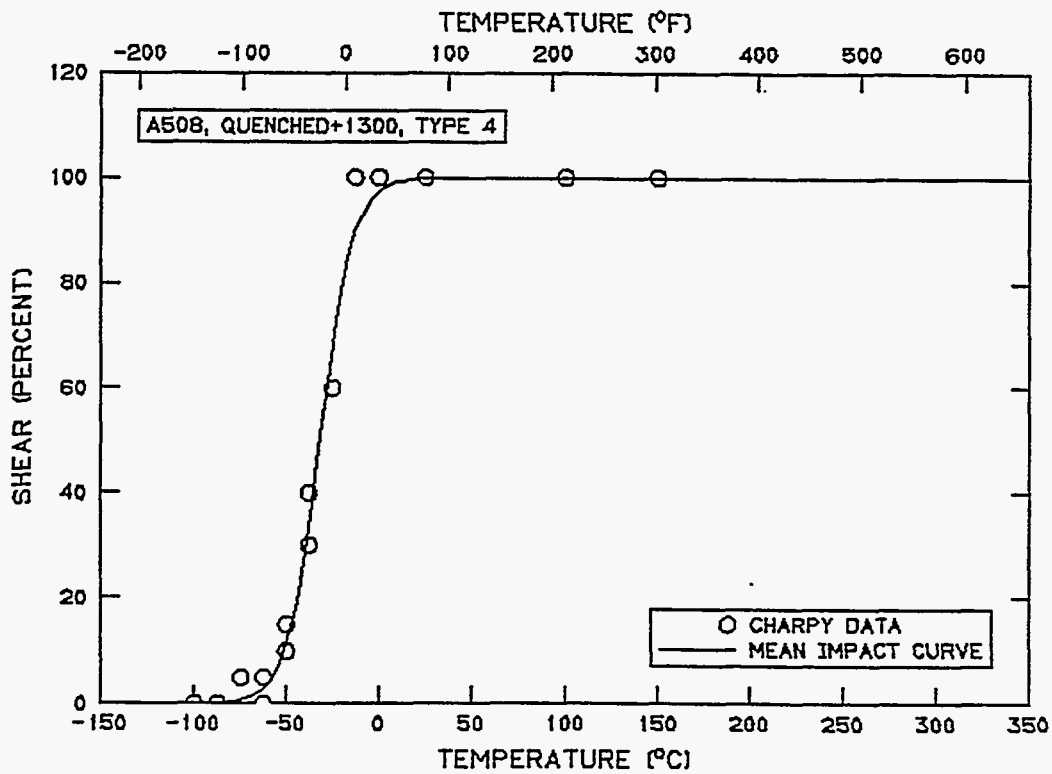

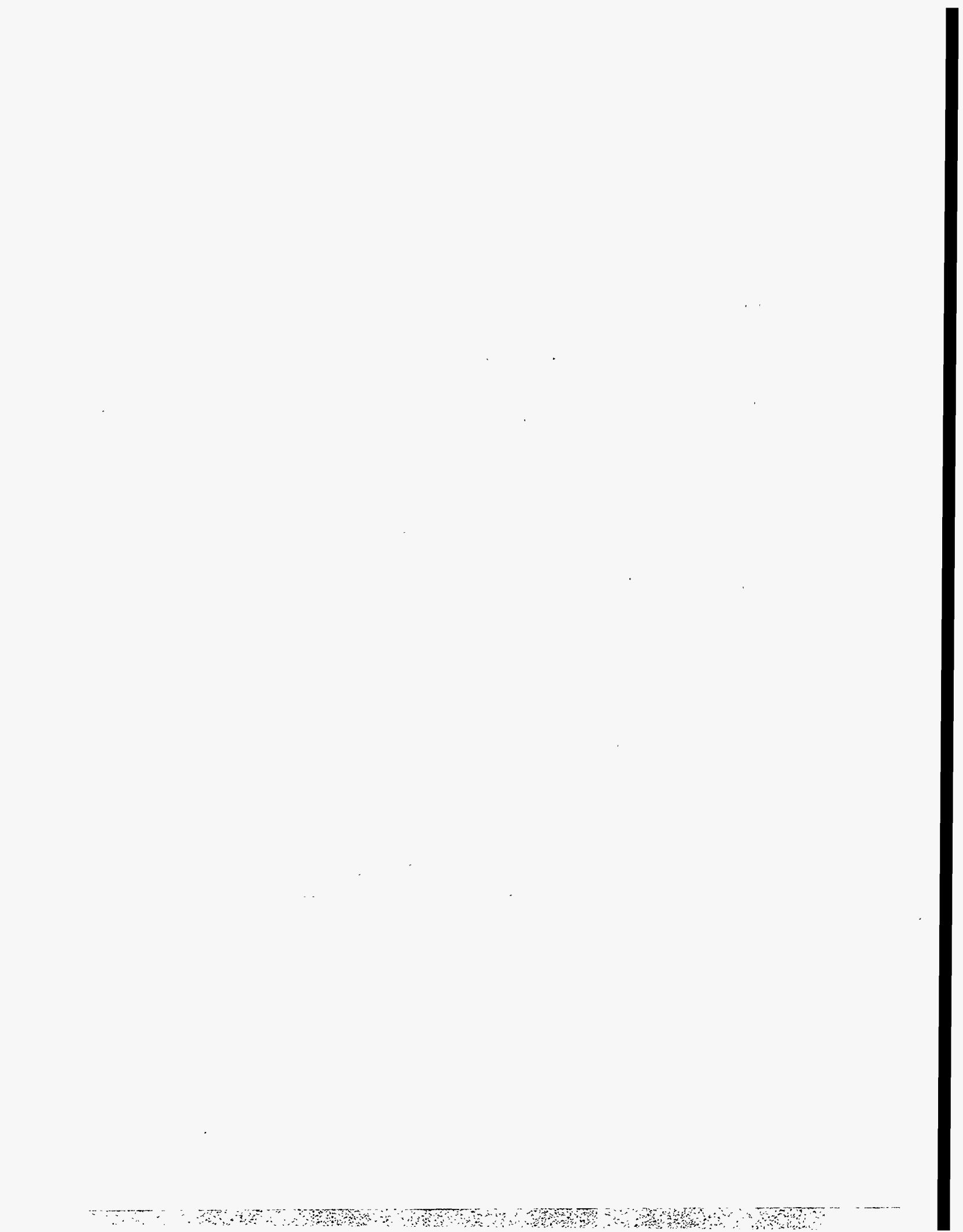

APPENDIX G

HSST PLATE 02, QUARTER THICKNESS,
TL ORIENTATION

SOURCE: ANALYSIS SET
ANALYSIS SET NAME: 02_F

SET NAME: 02_F
NOTE: PLATE 02 FULL-SIZE DATA

IDENT	TEMPERATURE		ENERGY (J)	EXPANSION (MM)	EXPANSION (IN)	SHEAR (PERCENT)	
	(DEG C)	(DEG F)					
1	-46.0	-50.8	10.20	7.52	UNKNOWN	UNKNOWN	
2	-18.0	-0.4	31.20	23.01	UNKNOWN	UNKNOWN	
3	-7.0	19.4	21.70	16.01	0.36	0.014	30.0
4	-7.0	19.4	24.40	18.00	0.43	0.017	20.0
5	-7.0	19.4	27.10	19.99	0.33	0.013	20.0
6	-7.0	19.4	27.10	19.99	0.38	0.015	20.0
7	-7.0	19.4	29.80	21.98	0.43	0.017	20.0
9	-7.0	19.4	32.50	23.97	0.43	0.017	20.0
10	-7.0	19.4	33.90	25.00	0.58	0.023	30.0
11	-7.0	19.4	35.90	26.48	0.46	0.018	20.0
12	-7.0	19.4	36.60	27.00	0.64	0.025	20.0
13	-7.0	19.4	40.70	30.02	0.56	0.022	20.0
14	10.0	50.0	52.90	39.02	UNKNOWN		20.0
15	21.0	69.8	52.90	39.02	0.79	0.031	40.0
16	21.0	69.8	55.60	41.01	0.86	0.034	40.0
17	21.0	69.8	56.90	41.97	0.84	0.033	40.0
18	21.0	69.8	58.30	43.00	0.94	0.037	40.0
19	21.0	69.8	58.30	43.00	0.76	0.030	35.0
20	21.0	69.8	62.40	46.02	0.91	0.036	40.0
21	21.0	69.8	67.80	50.01	0.89	0.035	30.0
22	21.0	69.8	69.20	51.04	1.07	0.042	40.0
23	21.0	69.8	70.50	52.00	1.12	0.044	40.0
24	21.0	69.8	78.90	58.19	0.86	0.034	30.0
25	38.0	100.4	80.70	59.52	UNKNOWN		35.0
26	66.0	150.8	107.10	78.99	1.60	0.063	80.0
27	66.0	150.8	108.50	80.03	1.40	0.055	85.0
29	66.0	150.8	111.20	82.02	1.47	0.058	80.0
30	66.0	150.8	112.30	82.83	1.60	0.063	90.0
31	66.0	150.8	112.50	82.98	1.60	0.063	85.0
32	66.0	150.8	113.90	84.01	1.55	0.061	80.0
33	66.0	150.8	122.00	89.98	UNKNOWN		85.0
34	66.0	150.8	127.40	93.97	1.75	0.069	100.0
35	66.0	150.8	127.40	93.97	1.60	0.063	100.0
36	66.0	150.8	130.20	96.03	1.68	0.066	100.0
37	66.0	150.8	130.30	96.11	1.70	0.067	90.0
38	93.0	199.4	139.60	102.97	1.83	0.072	100.0
39	121.0	249.8	141.00	104.00	1.96	0.077	100.0
40	149.0	300.2	130.20	96.03	2.11	0.083	100.0
41	149.0	300.2	132.90	98.02	1.88	0.074	100.0
42	149.0	300.2	132.90	98.02	1.88	0.074	100.0
43	149.0	300.2	135.60	100.01	1.80	0.071	100.0
44	149.0	300.2	138.30	102.01	1.83	0.072	100.0
45	149.0	300.2	138.30	102.01	2.24	0.088	100.0
46	149.0	300.2	139.60	102.97	1.83	0.072	100.0
47	149.0	300.2	143.70	105.99	1.83	0.072	100.0
48	149.0	300.2	143.70	105.99	1.91	0.075	100.0
49	149.0	300.2	149.10	109.97	1.93	0.076	100.0
50	149.0	300.2	151.90	112.04	1.70	0.067	100.0
51	177.0	350.6	145.10	107.02	2.11	0.083	100.0
52	204.0	399.2	127.40	93.97	2.06	0.081	100.0
53	204.0	399.2	130.20	96.03	1.78	0.070	100.0

54	204.0	399.2	130.20	96.03	1.75	0.069	100.0
55	204.0	399.2	135.60	100.01	2.01	0.079	100.0
56	204.0	399.2	136.30	100.53	1.80	0.071	100.0
57	204.0	399.2	136.90	100.97	1.80	0.071	100.0
58	204.0	399.2	138.30	102.01	1.47	0.058	100.0
59	204.0	399.2	141.00	104.00	2.01	0.079	100.0
60	204.0	399.2	142.40	105.03	2.11	0.083	100.0
61	204.0	399.2	146.40	107.98	1.93	0.076	100.0
62	204.0	399.2	157.30	116.02	1.75	0.069	100.0
63	232.0	449.6	139.00	102.52	2.01	0.079	100.0
64	260.0	500.0	140.30	103.48	2.06	0.081	100.0
65	288.0	550.4	119.30	87.99	1.78	0.070	100.0
66	288.0	550.4	132.90	98.02	1.78	0.070	100.0
67	288.0	550.4	134.20	98.98	1.73	0.068	100.0
68	288.0	550.4	139.40	102.82	UNKNOWN		UNKNOWN
69	288.0	550.4	142.40	105.03	1.83	0.072	100.0
70	288.0	550.4	143.70	105.99	1.60	0.063	100.0
71	288.0	550.4	146.40	107.98	1.91	0.075	100.0
72	288.0	550.4	146.40	107.98	2.01	0.079	100.0
73	288.0	550.4	149.10	109.97	2.11	0.083	100.0
74	288.0	550.4	150.50	111.00	UNKNOWN		UNKNOWN
75	288.0	550.4	151.90	112.04	1.78	0.070	100.0

NUMBER OF SPECIMENS: 73

SOURCE: 02_F ANALYSIS SET

Y VARIABLE: ENERGY

CONFIDENCE INTERVALS: MEAN AND PREDICTED VALUE

MODEL PARAMETERS

LOWER SHELF ENERGY [HELD FIXED]: 2.7 (J), 2.0 (FT-LB)
MID-TRANSITION TEMPERATURE: 26.5 (DEG C), 79.6 (DEG F)
TRANSITION ZONE WIDTH: 98.2 (C DEG), 176.7 (F DEG)
UPPER SHELF ENERGY: 140.6 (J), 103.7 (FT-LB)
UPPER SHELF ENERGY: 140.6 (J), 103.7 (FT-LB)
CONFIDENCE INTERVAL ON MEAN
95 PERCENT: 138 TO 143.2 (J), 101.8 TO 105.6 (FT-LB)
CONFIDENCE INTERVAL ON PREDICTED VALUE
95 PERCENT: 125 TO 156.3 (J), 92.2 TO 115.3 (FT-LB)
TEMPERATURE [41 (J), 30.2 (FT-LB) ENERGY]: 3.0 (DEG C), 37.4 (DEG F)
CONFIDENCE INTERVAL ON MEAN
95 PERCENT: -0.3 TO 6.1 (DEG C), 31.4 TO 43 (DEG F)
CONFIDENCE INTERVAL ON PREDICTED VALUE
95 PERCENT: -13.7 TO 15.7 (DEG C), 7.4 TO 60.3 (DEG F)
TEMPERATURE [68 (J), 50.2 (FT-LB) ENERGY]: 23.9 (DEG C), 75.0 (DEG F)
CONFIDENCE INTERVAL ON MEAN
95 PERCENT: 21.4 TO 26.4 (DEG C), 70.4 TO 79.5 (DEG F)
CONFIDENCE INTERVAL ON PREDICTED VALUE
95 PERCENT: 12.2 TO 35.3 (DEG C), 54 TO 95.5 (DEG F)
NOTE: HSST PLATE 02, TL ORIENTATION, 1/4 THICKNESS
MODEL SET NAME: 7

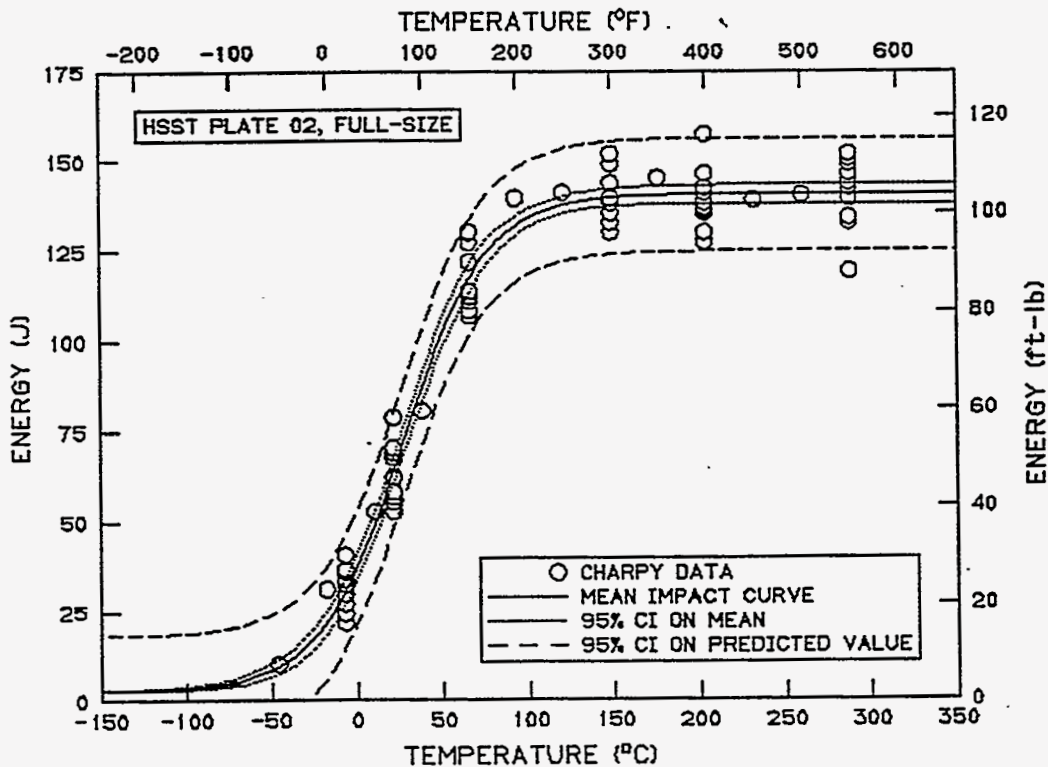

DATA SOURCE: ANALYSIS SET

ANALYSIS SET: 02_F

Y VARIABLE: SHEAR

MODEL PARAMETERS

LOWER SHELF SHEAR [HELD FIXED]: 0 (PERCENT)

MID-TRANSITION TEMPERATURE: 29.4 (DEG C), 85 (DEG F)

TRANSITION ZONE WIDTH: 87.2 (C DEG), 157 (F DEG)

UPPER SHELF SHEAR [HELD FIXED]: 100 (PERCENT)

UPPER SHELF SHEAR: 100 (PERCENT)

TEMPERATURE [50 (PERCENT), 50 (PERCENT) SHEAR]: 29.4 (DEG C), 85 (DEG F)

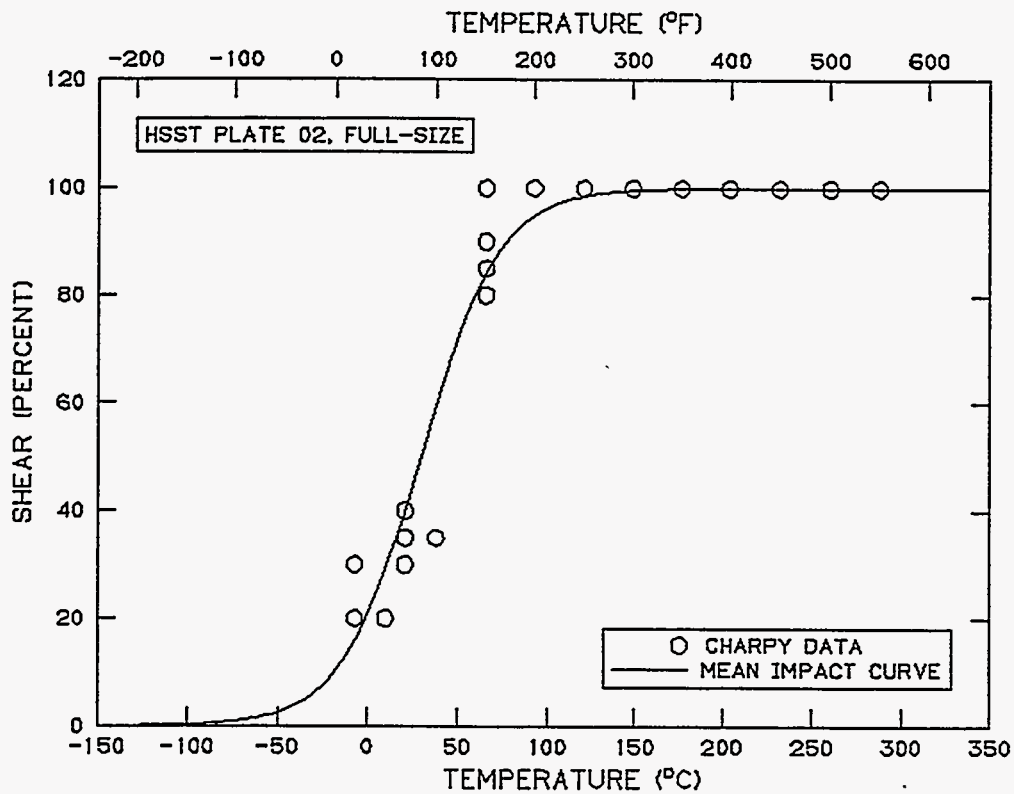

REMARK: PLATE 02 FULL-SIZE DATA

MODEL SET NAME: 02.FS

DATA SOURCE: ANALYSIS SET
 ANALYSIS SET: 02 F
 Y VARIABLE: EXPANSION
 MODEL PARAMETERS

LOWER SHELF EXPANSION [HELD FIXED]: 0.061 (MM), 0.0024 (IN)
 MID-TRANSITION TEMPERATURE: 24.8 (DEG C), 76.6 (DEG F)
 TRANSITION ZONE WIDTH: 98.5 (C DEG), 177.3 (F DEG)
 UPPER SHELF EXPANSION: 1.892 (MM), 0.0745 (IN)
 UPPER SHELF EXPANSION: 1.892 (MM), 0.0745 (IN)
 TEMPERATURE [0.89 (MM), 0.035 (IN) EXPANSION]: 20.1 (DEG C), 68.3 (DEG F)

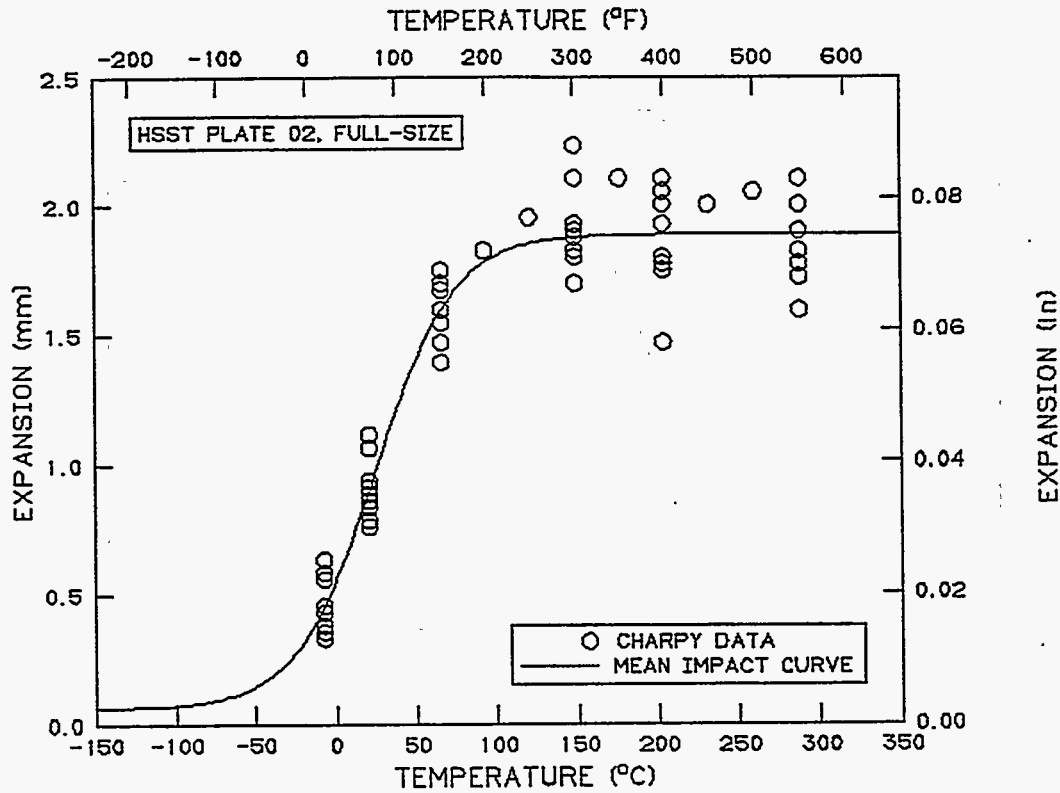

REMARK: PLATE 02 FULL-SIZE DATA
 MODEL SET NAME: 02.FE

SOURCE: ANALYSIS SET
ANALYSIS SET NAME: 02_T1

SET NAME: 02 T1

NOTE: SUB-SIZE CORRELATION PROGRAM - HSST 02 - SPECIMEN TYPE 1

IDENT	TEMPERATURE		ENERGY		EXPANSION		SHEAR (PERCENT)
	(DEG C)	(DEG F)	(J)	(FT-LB)	(MM)	(IN)	
0251	-100.0	-148.0	0.27	0.20	0.00	0.000	0.0
0240	-87.5	-125.5	0.81	0.60	0.00	0.000	0.0
0239	-75.0	-103.0	1.36	1.00	0.00	0.000	0.0
0238	-62.5	-80.5	1.63	1.20	0.00	0.000	5.0
0237	-50.0	-58.0	5.02	3.70	0.15	0.006	5.0
0236	-37.5	-35.5	3.80	2.80	0.10	0.004	5.0
0235	-25.0	-13.0	8.81	6.50	0.36	0.014	15.0
0234	-12.5	9.5	10.85	8.00	0.48	0.019	25.0
0233	0.0	32.0	9.36	6.90	0.46	0.018	25.0
0252	12.5	54.5	10.58	7.80	0.46	0.018	35.0
0253	25.0	77.0	20.07	14.80	0.76	0.030	65.0
0254	37.5	99.5	21.42	15.80	0.91	0.036	80.0
0258	75.0	167.0	32.00	23.60	1.02	0.040	100.0
0255	100.0	212.0	24.95	18.40	0.97	0.038	100.0
0256	150.0	302.0	28.61	21.10	0.94	0.037	100.0
0257	200.0	392.0	28.88	21.30	0.99	0.039	100.0

NUMBER OF SPECIMENS: 16

SOURCE: 02_T1 ANALYSIS SET

Y VARIABLE: ENERGY

MODEL PARAMETERS

LOWER SHELF ENERGY [HELD FIXED]: 0.1 (J), 0.1 (FT-LB)

MID-TRANSITION TEMPERATURE: 11.3 (DEG C), 52.3 (DEG F)

TRANSITION ZONE WIDTH: 111.4 (C DEG), 200.4 (F DEG)

UPPER SHELF ENERGY: 29.4 (J), 21.7 (FT-LB)

UPPER SHELF ENERGY: 29.4 (J), 21.7 (FT-LB)

NOTE: NONE

MODEL SET NAME: 2

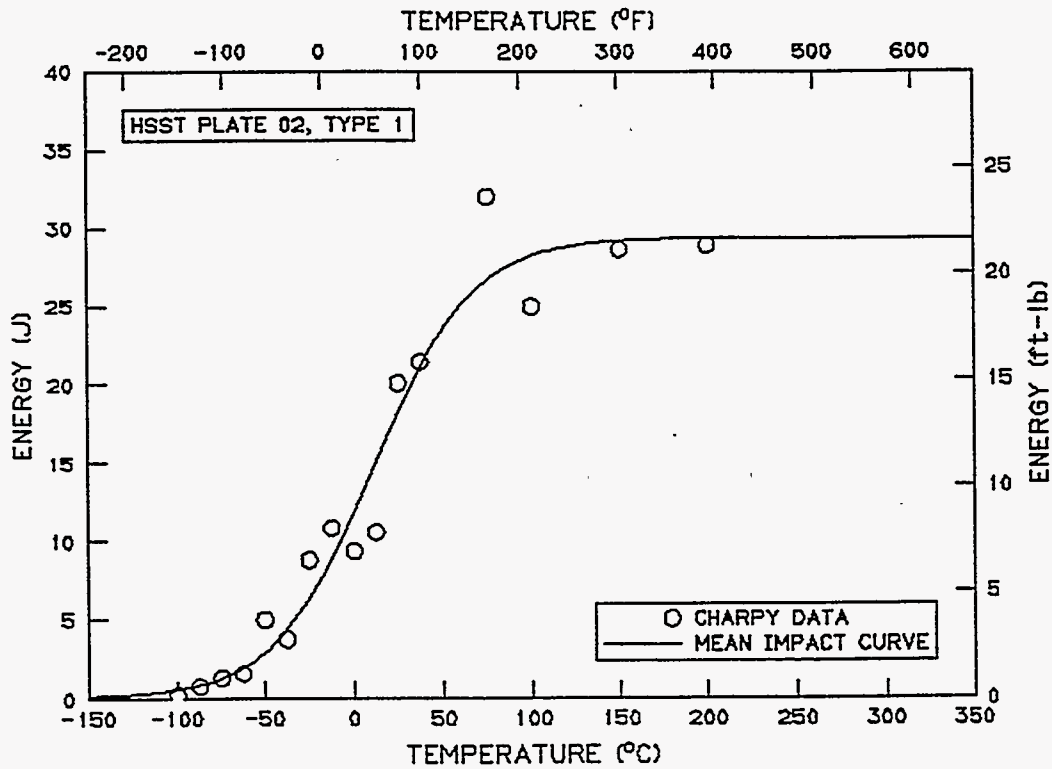

SOURCE: 02_T1 ANALYSIS SET

Y VARIABLE: EXPANSION

MODEL PARAMETERS

LOWER SHELF EXPANSION [HELD FIXED]: 0.000 (MM), 0.0000 (IN)

MID-TRANSITION TEMPERATURE: -0.4 (DEG C), 31.3 (DEG F)

TRANSITION ZONE WIDTH: 94.3 (C DEG), 169.7 (F DEG)

UPPER SHELF EXPANSION: 0.994 (MM), 0.0391 (IN)

UPPER SHELF EXPANSION: 0.994 (MM), 0.0391 (IN)

NOTE: NONE

MODEL SET NAME: 3

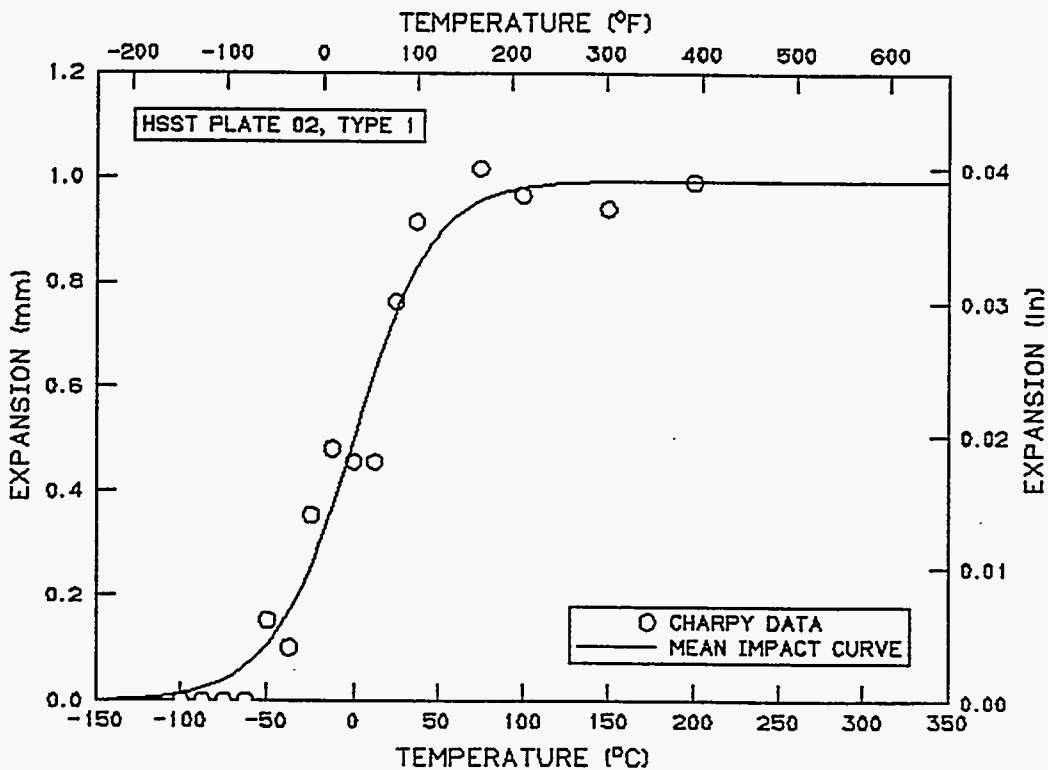

SOURCE: 02_T1 ANALYSIS SET

Y VARIABLE: SHEAR

MODEL PARAMETERS

LOWER SHELF SHEAR [HELD FIXED]: 0 (PERCENT)

MID-TRANSITION TEMPERATURE: 16.3 (DEG C), 61.3 (DEG F)

TRANSITION ZONE WIDTH: 74.1 (C DEG), 133.3 (F DEG)

UPPER SHELF SHEAR [HELD FIXED]: 100 (PERCENT)

UPPER SHELF SHEAR: 100 (PERCENT)

NOTE: NONE

MODEL SET NAME: 4

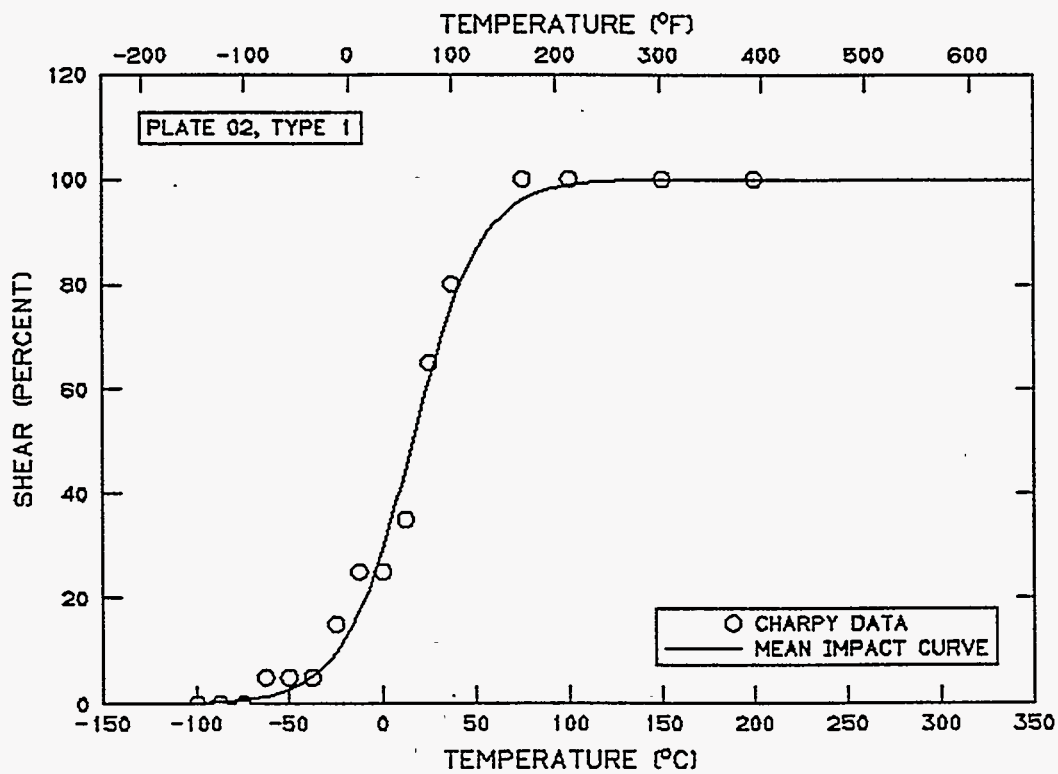

SOURCE: ANALYSIS SET
ANALYSIS SET NAME: 02_T2

SET NAME: 02 T2

NOTE: SUB-SIZE CORRELATION PROGRAM - HSST PLATE 02 - TYPE 2 SPEC.

IDENT	TEMPERATURE		ENERGY (J)	EXPANSION			SHEAR (PERCENT)
	(DEG C)	(DEG F)		(FT-LB)	(MM)	(IN)	
0229	-87.5	-125.5	0.14	0.10	0.00	0.000	0.0
0228	-75.0	-103.0	0.14	0.10	0.00	0.000	0.0
0227	-62.5	-80.5	0.68	0.50	0.00	0.000	5.0
0231	-60.0	-76.0	3.80	2.80	0.30	0.012	20.0
0230	-58.0	-72.4	1.63	1.20	0.05	0.002	10.0
0232	-54.0	-65.2	3.53	2.60	0.20	0.008	15.0
0221	-50.0	-58.0	4.20	3.10	0.28	0.011	20.0
0222	-37.5	-35.5	4.61	3.40	0.25	0.010	15.0
0223	-25.0	-13.0	6.24	4.60	0.43	0.017	45.0
0224	-12.5	9.5	3.80	2.80	0.25	0.010	40.0
0225	0.0	32.0	7.05	5.20	0.51	0.020	85.0
0226	12.5	54.5	5.97	4.40	0.41	0.016	90.0
0267	100.0	212.0	7.32	5.40	0.56	0.022	100.0
0269	150.0	302.0	7.73	5.70	0.61	0.024	100.0
0268	200.0	392.0	6.78	5.00	0.64	0.025	100.0

NUMBER OF SPECIMENS: 15

SOURCE: 02_T2 ANALYSIS SET

Y VARIABLE: ENERGY

MODEL PARAMETERS

LOWER SHELF ENERGY [HELD FIXED]: 0.1 (J), 0.1 (FT-LB)

MID-TRANSITION TEMPERATURE: -50.2 (DEG C), -58.3 (DEG F)

TRANSITION ZONE WIDTH: 53.7 (C DEG), 96.6 (F DEG)

UPPER SHELF ENERGY: 6.7 (J), 4.9 (FT-LB)

UPPER SHELF ENERGY: 6.7 (J), 4.9 (FT-LB)

NOTE: NONE

MODEL SET NAME: 7

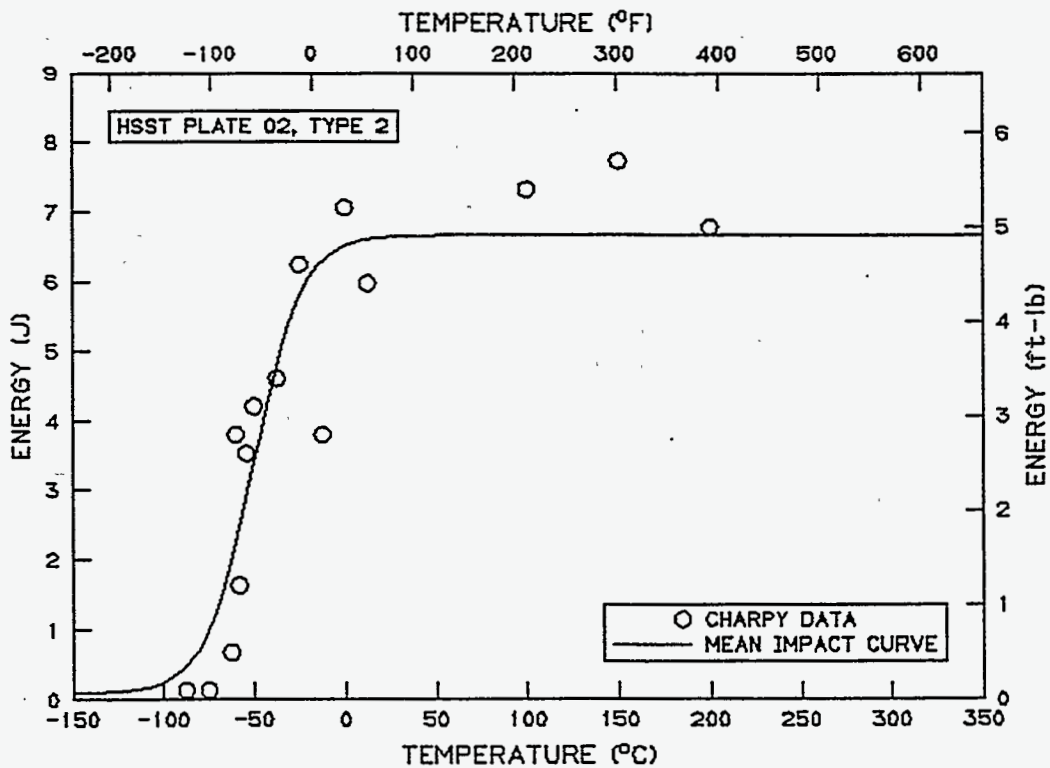

MODEL PARAMETERS

LOWER SHELF EXPANSION [HELD FIXED]: 0.000 (MM), 0.0000 (IN)
MID-TRANSITION TEMPERATURE: -29.2 (DEG C), -20.6 (DEG F)
TRANSITION ZONE WIDTH: 105.3 (C DEG), 189.5 (F DEG)
UPPER SHELF EXPANSION: 0.590 (MM), 0.0232 (IN)
UPPER SHELF EXPANSION: 0.590 (MM), 0.0232 (IN)
NOTE: NONE
MODEL SET NAME: 6

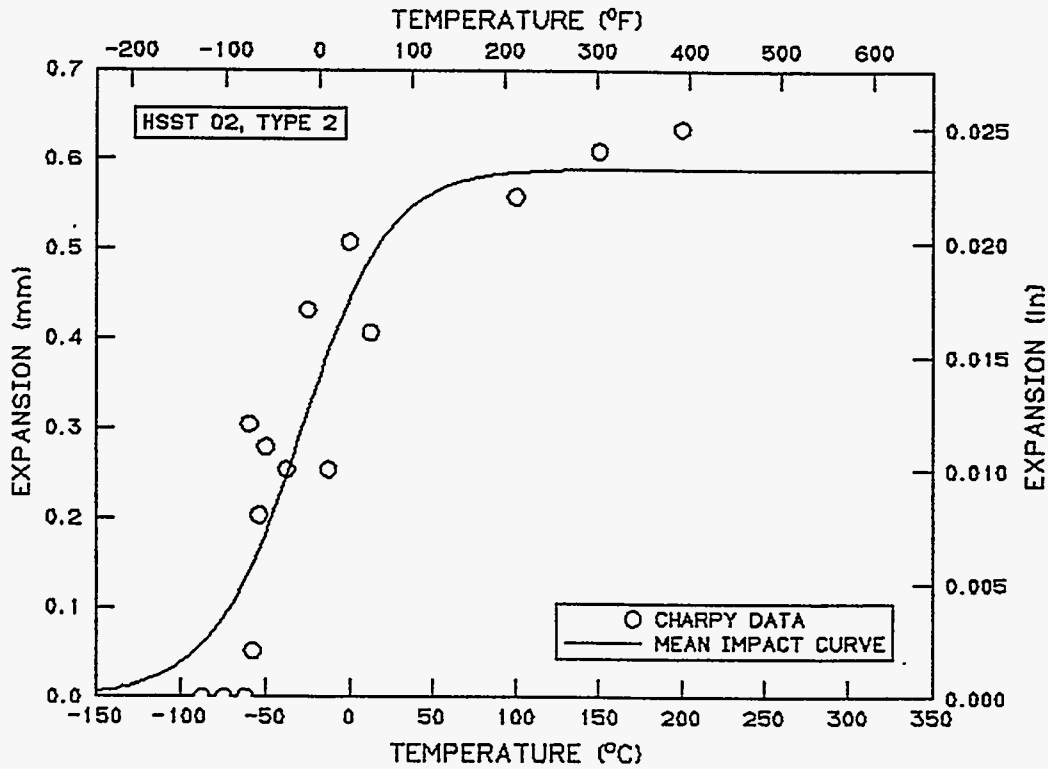

SOURCE: 02_T2 ANALYSIS SET

Y VARIABLE: SHEAR

MODEL PARAMETERS

LOWER SHELF SHEAR [HELD FIXED]: 0 (PERCENT)

MID-TRANSITION TEMPERATURE:-17.7 (DEG C),0.1 (DEG F)

TRANSITION ZONE WIDTH: 69.9 (C DEG),125.9 (F DEG)

UPPER SHELF SHEAR [HELD FIXED]: 100 (PERCENT)

UPPER SHELF SHEAR: 100 (PERCENT)

NOTE: NONE

MODEL SET NAME: 5

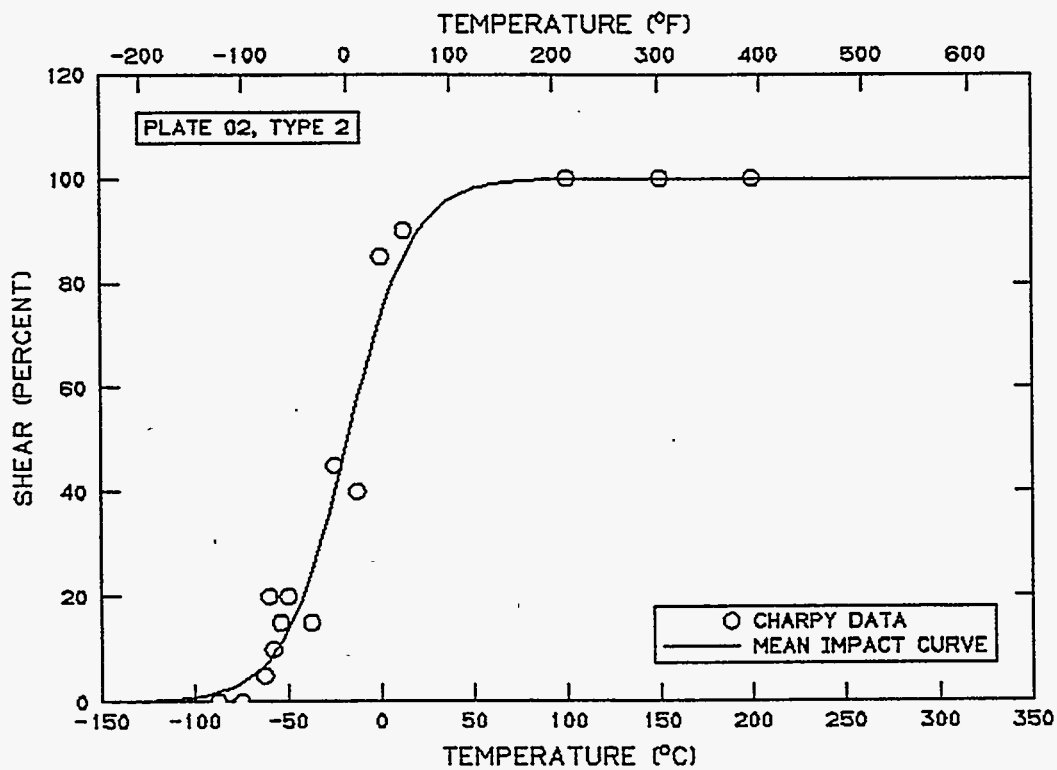

SOURCE: ANALYSIS SET

ANALYSIS SET NAMES: 02_TYP3.NH AND 02_TYP3.FH

SET NAME: 02_TYP3.NH

NOTE: TYPE 3 SUB CVN, PLATE 02, FROM LOW HEIGHT 51.2 FT-LBS

IDENT	TEMPERATURE		ENERGY (J)	(FT-LB)	EXPANSION		SHEAR (PERCENT)
	(DEG C)	(DEG F)			(MM)	(IN)	
02NB	-100.0	-148.0	0.80	0.59	0.00	0.000	0.0
02NJ	-75.0	-103.0	1.84	1.36	0.05	0.002	5.0
02NG	-50.0	-58.0	4.45	3.28	0.18	0.007	10.0
02MQ	-37.5	-35.5	8.65	6.38	0.43	0.017	20.0
02MS	-25.0	-13.0	13.50	9.96	0.66	0.026	25.0
02NF	-12.5	9.5	13.94	10.28	0.74	0.029	35.0
02MZ	0.0	32.0	14.41	10.63	0.71	0.028	40.0
02NN	25.0	77.0	21.92	16.17	1.02	0.040	70.0
02MT	50.0	122.0	20.78	15.33	1.04	0.041	90.0
02NI	100.0	212.0	24.97	18.42	1.07	0.042	100.0
02NK	150.0	302.0	24.69	18.21	0.97	0.038	100.0
02MU	200.0	392.0	27.08	19.97	1.09	0.043	100.0

NUMBER OF SPECIMENS: 12

SET NAME: 02_TYP3.FH

NOTE: TYPE 3 SUB CVN, PLATE 02, FROM FULL HEIGHT 300 FT-LBS

IDENT	TEMPERATURE		ENERGY (J)	(FT-LB)	EXPANSION		SHEAR (PERCENT)
	(DEG C)	(DEG F)			(MM)	(IN)	
02NM	-100.0	-148.0	0.89	0.66	0.00	0.000	0.0
02MR	-75.0	-103.0	1.94	1.43	0.05	0.002	5.0
02NA	-50.0	-58.0	4.60	3.39	0.18	0.007	10.0
02NE	-37.5	-35.5	7.80	5.75	0.36	0.014	15.0
02MW	-25.0	-13.0	9.59	7.07	0.46	0.018	20.0
02NH	-12.5	9.5	10.82	7.98	0.56	0.022	30.0
02MA	0.0	32.0	12.87	9.49	0.64	0.025	35.0
02NC	25.0	77.0	17.52	12.92	0.79	0.031	50.0
02MY	50.0	122.0	22.80	16.82	0.94	0.037	65.0
02ND	100.0	212.0	24.87	18.34	0.97	0.038	99.0
02MV	150.0	302.0	27.33	20.16	0.94	0.037	100.0
02MP	200.0	392.0	29.12	21.48	1.17	0.046	100.0

NUMBER OF SPECIMENS: 12

SOURCE: 02_T3_14 ANALYSIS SET

Y VARIABLE: ENERGY

MODEL PARAMETERS

LOWER SHELF ENERGY [HELD FIXED]: 0.1 (J), 0.1 (FT-LB)

MID-TRANSITION TEMPERATURE: -6.2 (DEG C), 20.9 (DEG F)

TRANSITION ZONE WIDTH: 132.3 (C DEG), 238.2 (F DEG)

UPPER SHELF ENERGY: 26.7 (J), 19.7 (FT-LB)

UPPER SHELF ENERGY: 26.7 (J), 19.7 (FT-LB)

NOTE: HSST PLATE 02, TYPE 3, 2.25 AND 5.5 M/S

MODEL SET NAME: 8

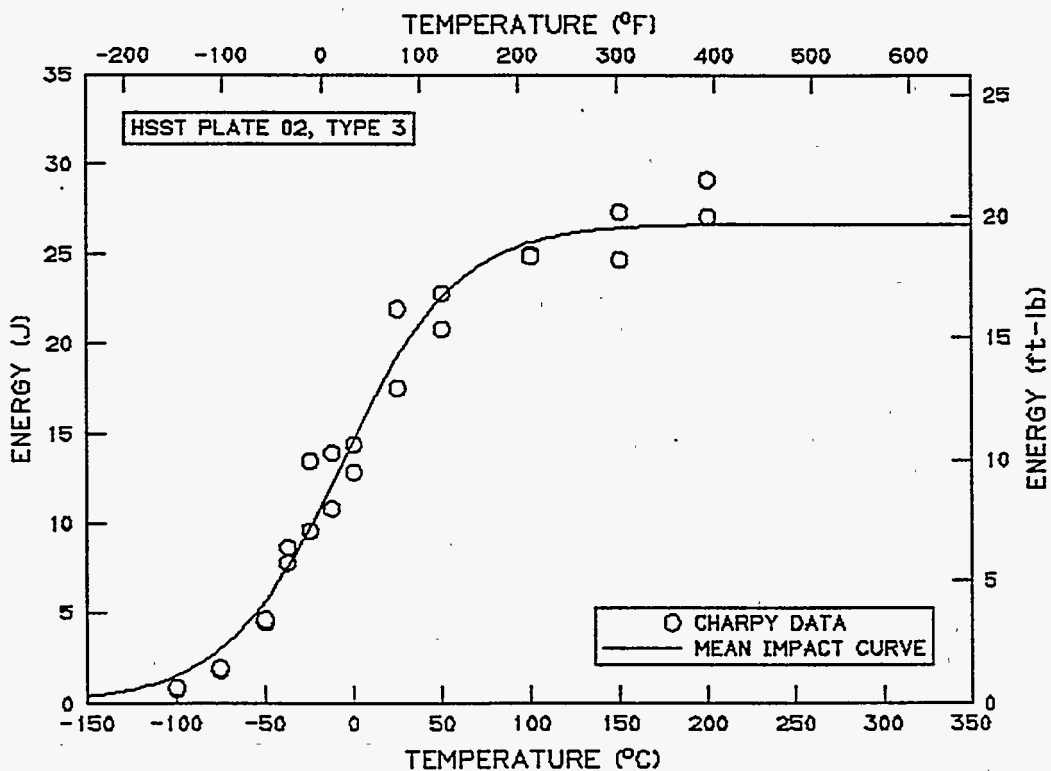

SOURCE: 02_T3_14 ANALYSIS SET

Y VARIABLE: EXPANSION

MODEL PARAMETERS

LOWER SHELF EXPANSION [HELD FIXED]: 0.000 (MM), 0.0000 (IN)

MID-TRANSITION TEMPERATURE: -22.8 (DEG C), -9.0 (DEG F)

TRANSITION ZONE WIDTH: 90.4 (C DEG), 162.7 (F DEG)

UPPER SHELF EXPANSION: 1.026 (MM), 0.0404 (IN)

UPPER SHELF EXPANSION: 1.026 (MM), 0.0404 (IN)

NOTE: NONE

MODEL SET NAME: 9

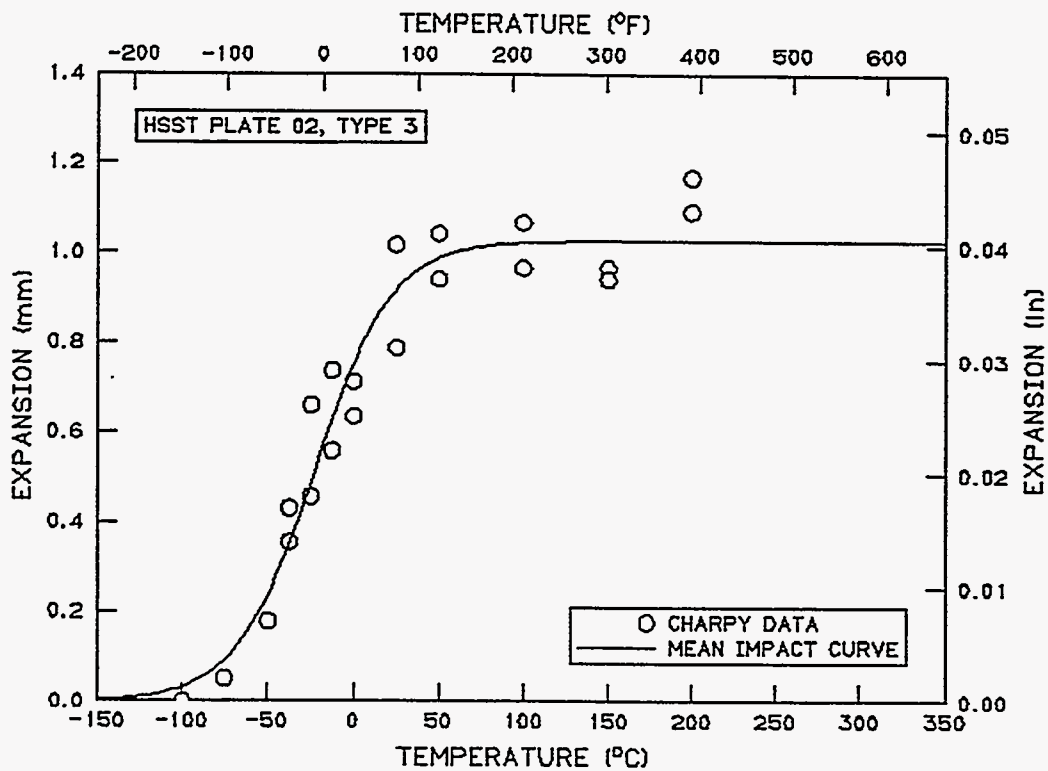

SOURCE: 02_T3_14 ANALYSIS SET

Y VARIABLE: SHEAR

MODEL PARAMETERS

LOWER SHELF SHEAR [HELD FIXED]: 0 (PERCENT)
MID-TRANSITION TEMPERATURE: 12.1 (DEG C), 53.8 (DEG F)
TRANSITION ZONE WIDTH: 117.7 (C DEG), 211.8 (F DEG)
UPPER SHELF SHEAR [HELD FIXED]: 100 (PERCENT)
UPPER SHELF SHEAR: 100 (PERCENT)
NOTE: NONE
MODEL SET NAME: 0

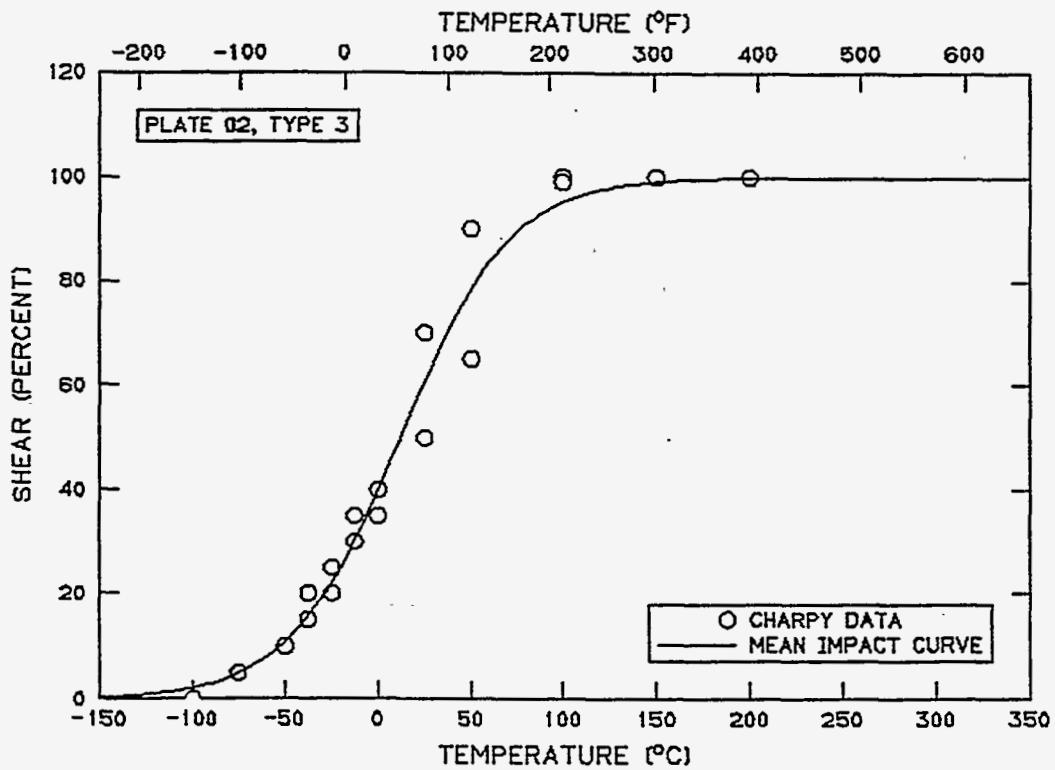

SOURCE: ANALYSIS SET
ANALYSIS SET NAME: 02_T4

SET NAME: 02_T4
NOTE: NONE

IDENT	TEMPERATURE		ENERGY (J)	EXPANSION		SHEAR (PERCENT)	
	(DEG C)	(DEG F)		(FT-LB)	(MM) (IN)		
0261	-87.5	-125.5	0.00	0.00	0.00	0.000	0.0
0202	-75.0	-103.0	0.00	0.00	0.00	0.000	0.0
0201	-73.3	-100.0	0.27	0.20	0.00	0.000	5.0
0212	-62.5	-80.5	0.41	0.30	0.00	0.000	5.0
0203	-50.0	-58.0	0.81	0.60	0.03	0.001	10.0
0211	-37.5	-35.5	1.90	1.40	0.18	0.007	10.0
0204	-25.0	-13.0	2.44	1.80	0.25	0.010	20.0
0210	-8.5	16.7	3.12	2.30	0.38	0.015	40.0
0205	0.0	32.0	4.61	3.40	0.46	0.018	50.0
0209	12.5	54.5	5.56	4.10	0.58	0.023	75.0
0206	25.0	77.0	5.29	3.90	0.43	0.017	90.0
0264	37.5	99.5	5.83	4.30	0.64	0.025	100.0
0207	50.0	122.0	5.83	4.30	0.66	0.026	100.0
0208	75.0	167.0	5.83	4.30	0.61	0.024	100.0
02C4	75.0	167.0	7.73	5.70	0.64	0.025	100.0
0262	87.5	189.5	5.97	4.40	0.58	0.023	100.0
0263	100.0	212.0	5.83	4.30	0.64	0.025	100.0
02C5	100.0	212.0	6.64	4.90	0.58	0.023	100.0
02C6	125.0	257.0	6.33	4.67	0.61	0.024	100.0

NUMBER OF SPECIMENS: 19

SOURCE: 02_T4 ANALYSIS SET

Y VARIABLE: ENERGY

MODEL PARAMETERS

LOWER SHELF ENERGY [HELD FIXED]: 0.1 (J), 0.1 (FT-LB)

MID-TRANSITION TEMPERATURE: -14.1 (DEG C), 6.6 (DEG F)

TRANSITION ZONE WIDTH: 74.7 (C DEG), 134.5 (F DEG)

UPPER SHELF ENERGY: 6.3 (J), 4.7 (FT-LB)

UPPER SHELF ENERGY: 6.3 (J), 4.7 (FT-LB)

NOTE: NONE

MODEL SET NAME: 3

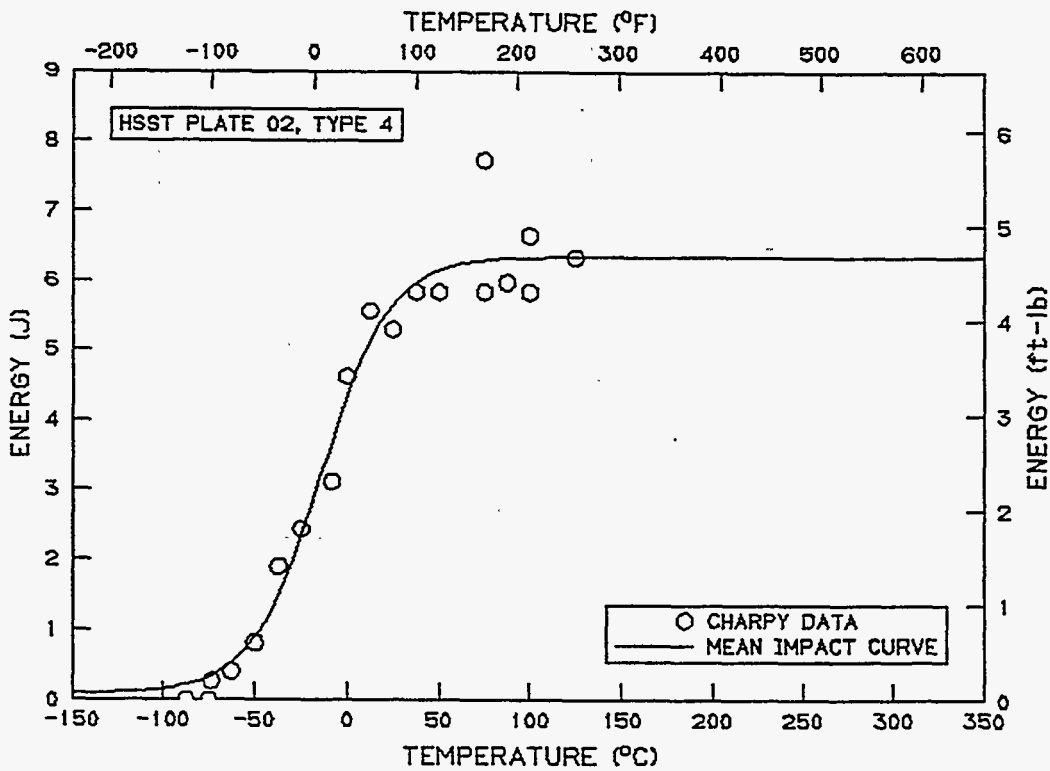

SOURCE: 02_T4 ANALYSIS SET

Y VARIABLE: EXPANSION

MODEL PARAMETERS

LOWER SHELF EXPANSION [HELD FIXED]: 0.000 (MM), 0.0000 (IN)

MID-TRANSITION TEMPERATURE: -17.8 (DEG C), 0.0 (DEG F)

TRANSITION ZONE WIDTH: 62.9 (C DEG), 113.3 (F DEG)

UPPER SHELF EXPANSION: 0.611 (MM), 0.0241 (IN)

UPPER SHELF EXPANSION: 0.611 (MM), 0.0241 (IN)

NOTE: NONE

MODEL SET NAME: 2

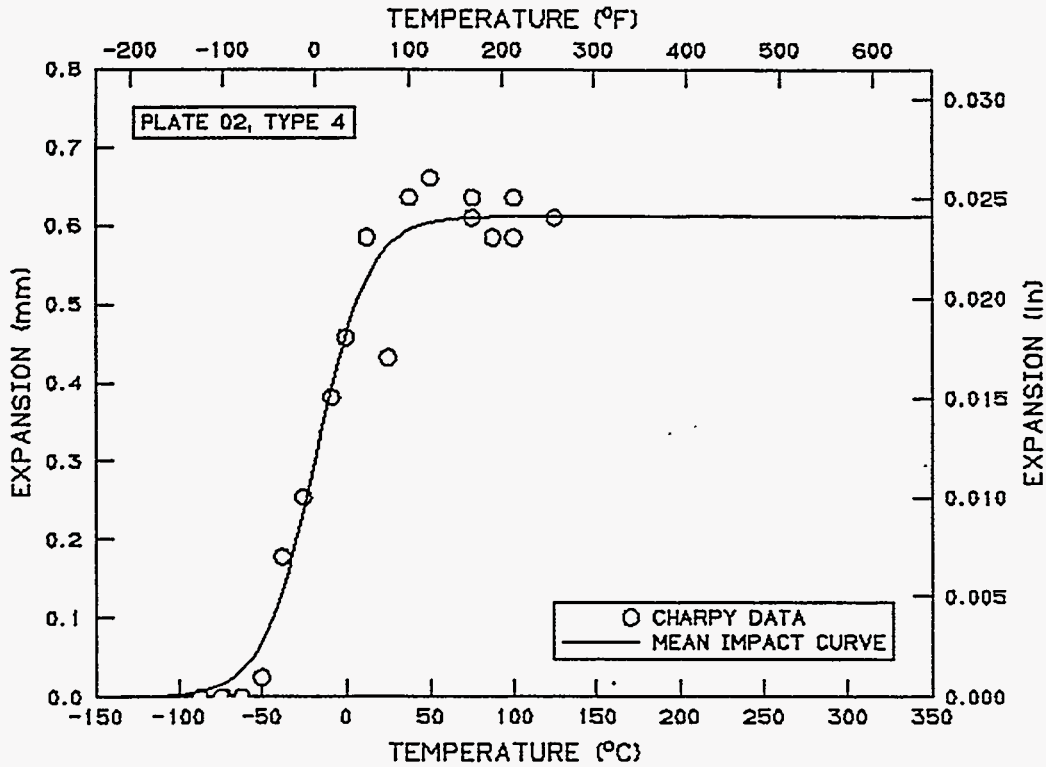

SOURCE: 02_T4 ANALYSIS SET

Y VARIABLE: SHEAR

MODEL PARAMETERS

LOWER SHELF SHEAR [HELD FIXED]: 0 (PERCENT)

MID-TRANSITION TEMPERATURE:-3.1 (DEG C), 26.4 (DEG F)

TRANSITION ZONE WIDTH: 58.6 (C DEG), 105.5 (F DEG)

UPPER SHELF SHEAR [HELD FIXED]: 100 (PERCENT)

UPPER SHELF SHEAR: 100 (PERCENT)

NOTE: NONE

MODEL SET NAME: 1

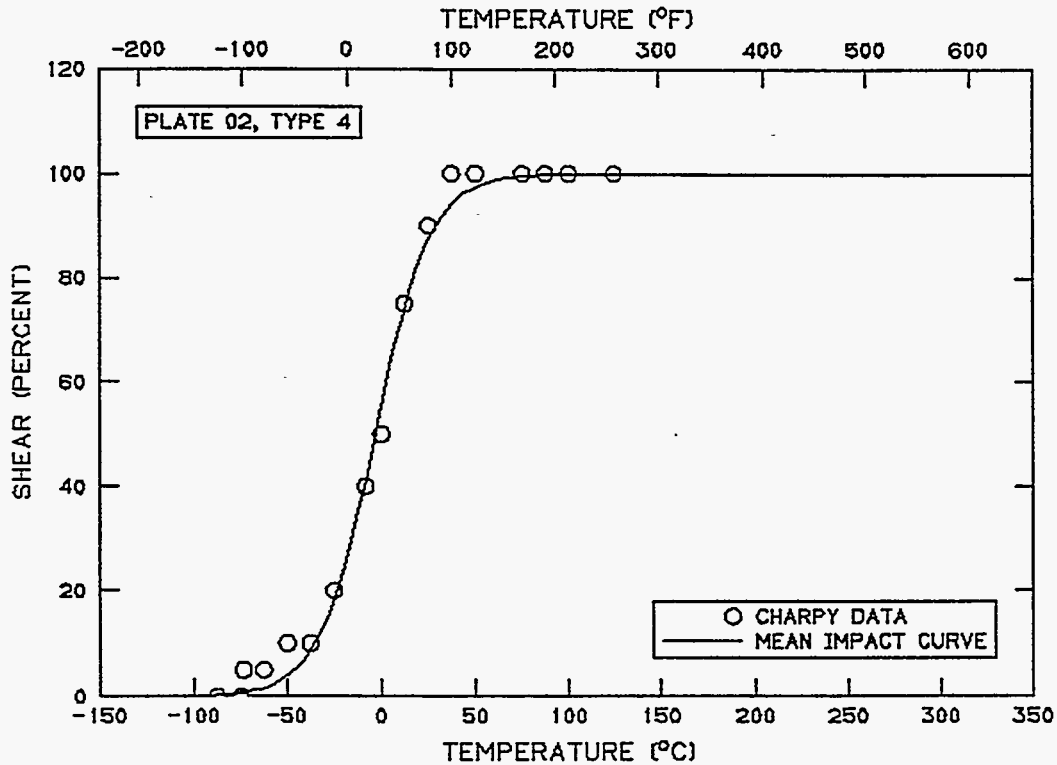

SOURCE: ANALYSIS SET
ANALYSIS SET NAME: HSST02_T.3A

SET NAME: HSST02 T.3A

NOTE: HSST PLATE 02 TYPE 3 WITH A DEEPER THAN USUAL NOTCH, 0.065"

IDENT	TEMPERATURE		ENERGY		EXPANSION		SHEAR (PERCENT)
	(DEG C)	(DEG F)	(J)	(FT-LB)	(MM)	(IN)	
0215	-87.5	-125.5	0.54	0.40	0.00	0.000	0.0
0214	-62.5	-80.5	0.81	0.60	0.00	0.000	5.0
0213	-50.0	-58.0	1.90	1.40	0.03	0.001	10.0
0216	-37.5	-35.5	5.15	3.80	0.25	0.010	2.0
0248	-37.5	-35.5	4.20	3.10	0.15	0.006	25.0
0217	-25.0	-13.0	5.97	4.40	0.30	0.012	30.0
0218	-12.5	9.5	7.59	5.60	0.36	0.014	45.0
0219	0.0	32.0	8.41	6.20	0.41	0.016	55.0
0220	25.0	77.0	11.39	8.40	0.64	0.025	80.0
0241	50.0	122.0	10.98	8.10	0.51	0.020	90.0
0242	62.5	144.5	14.51	10.70	0.71	0.028	100.0
0243	76.0	168.8	14.37	10.60	0.69	0.027	100.0
0244	87.5	189.5	13.29	9.80	0.64	0.025	100.0
0245	100.0	212.0	10.85	8.00	0.58	0.023	100.0
0247	150.0	302.0	13.02	9.60	0.69	0.027	100.0
0246	200.0	392.0	12.88	9.50	0.76	0.030	100.0

NUMBER OF SPECIMENS: 16

SOURCE: HSST02_T.3A ANALYSIS SET

Y VARIABLE: ENERGY

MODEL PARAMETERS

LOWER SHELF ENERGY [HELD FIXED]: 0.1 (J), 0.1 (FT-LB)

MID-TRANSITION TEMPERATURE: -19.1 (DEG C), -2.4 (DEG F)

TRANSITION ZONE WIDTH: 88.3 (C DEG), 158.9 (F DEG)

UPPER SHELF ENERGY: 13.0 (J), 9.6 (FT-LB)

UPPER SHELF ENERGY: 13.0 (J), 9.6 (FT-LB)

NOTE: NONE

MODEL SET NAME: 5

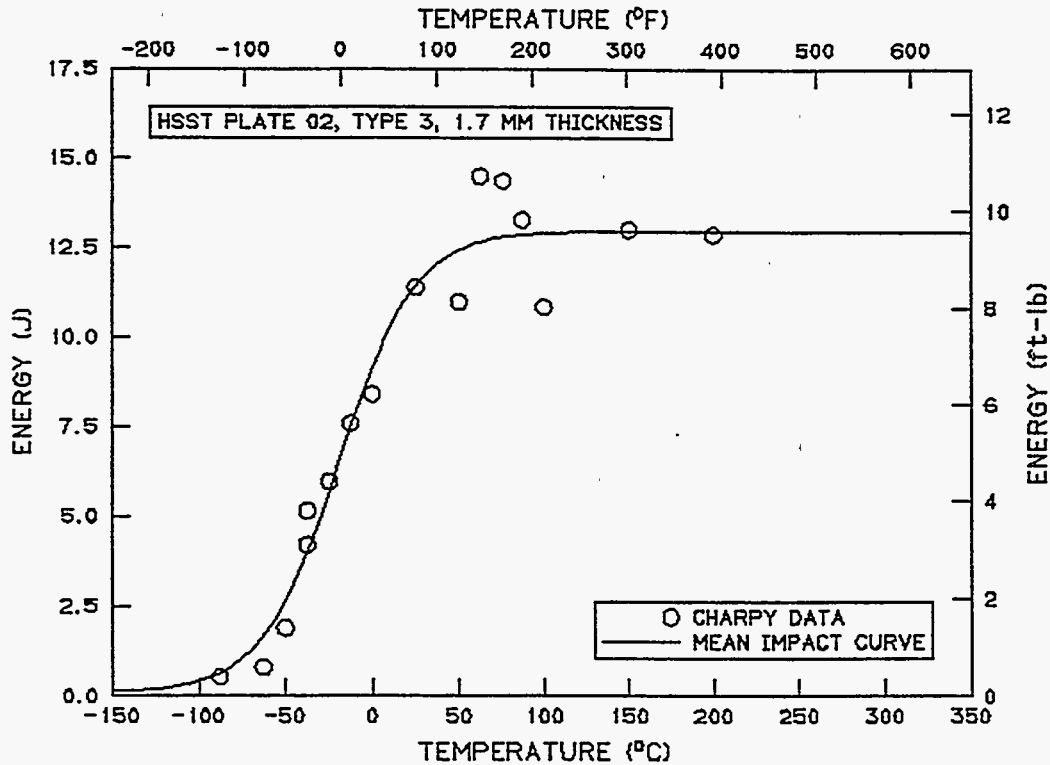

SOURCE: HSST02_T.3A ANALYSIS SET

Y VARIABLE: EXPANSION

MODEL PARAMETERS

LOWER SHELF EXPANSION [HELD FIXED]: 0.000 (MM), 0.0000 (IN)

MID-TRANSITION TEMPERATURE: -15.6 (DEG C), 3.9 (DEG F)

TRANSITION ZONE WIDTH: 80.5 (C DEG), 144.9 (F DEG)

UPPER SHELF EXPANSION: 0.665 (MM), 0.0262 (IN)

UPPER SHELF EXPANSION: 0.665 (MM), 0.0262 (IN)

NOTE: NONE

MODEL SET NAME: 4

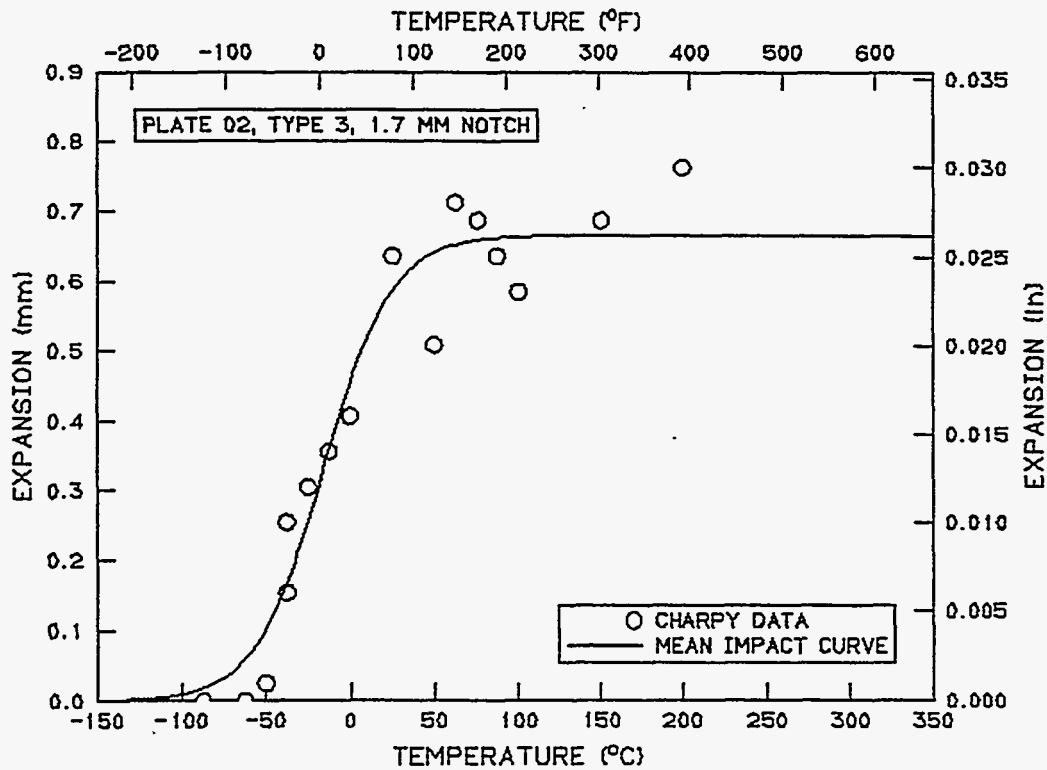

SOURCE: HSST02_T.3A ANALYSIS SET

Y VARIABLE: SHEAR

MODEL PARAMETERS

LOWER SHELF SHEAR [HELD FIXED]: 0 (PERCENT)

MID-TRANSITION TEMPERATURE: -5.1 (DEG C), 22.8 (DEG F)

TRANSITION ZONE WIDTH: 80.3 (C DEG), 144.5 (F DEG)

UPPER SHELF SHEAR [HELD FIXED]: 100 (PERCENT)

UPPER SHELF SHEAR: 100 (PERCENT)

NOTE: NONE

MODEL SET NAME: 3

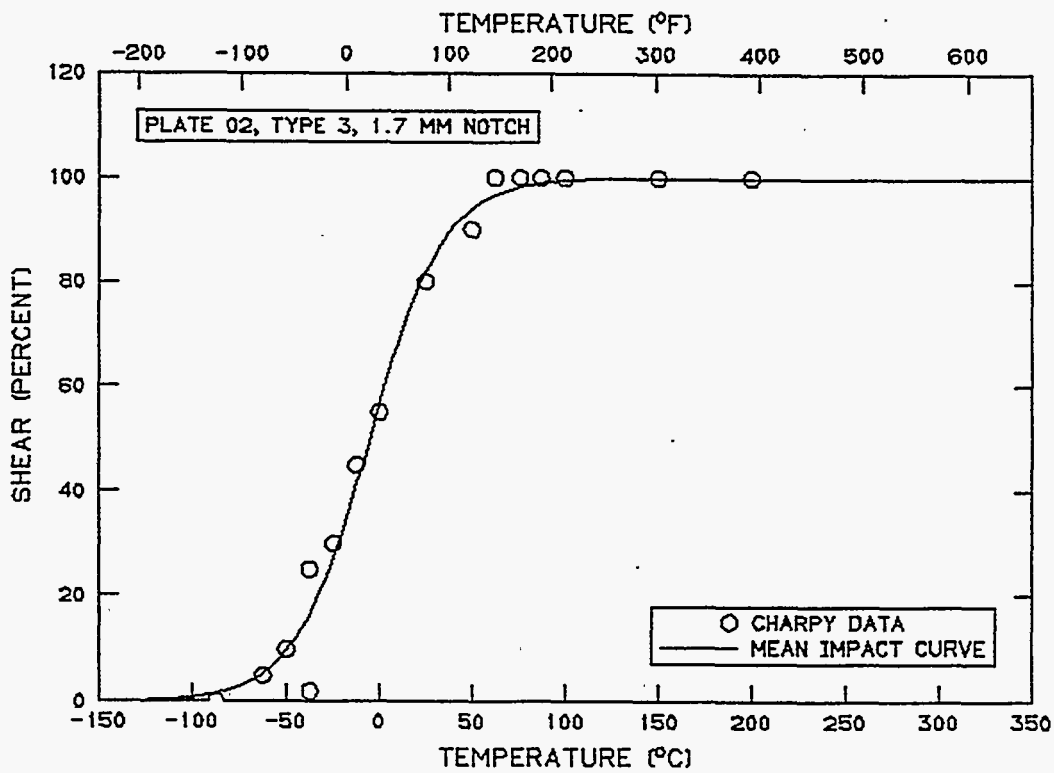

SOURCE: ANALYSIS SET
ANALYSIS SET NAME: 02_T3.1R

SET NAME: 02 T3.1R

NOTE: HSST PLATE 02, TYPE 3, 0.8 MM NOTCH, 0.1mm ROOT RAD

IDENT	TEMPERATURE		ENERGY (J)	EXPANSION (MM)	EXPANSION		SHEAR (PERCENT)
	(DEG C)	(DEG F)			(FT-LB)	(IN)	
02MT	-79.8	-111.6	0.99	0.73	0.00	0.000	0.0
02MS	-51.8	-61.3	3.35	2.47	0.08	0.003	0.0
02MU	-37.5	-35.5	6.06	4.47	0.15	0.006	10.0
02MR	-25.8	-14.4	6.63	4.89	0.23	0.009	15.0
02MV	-12.5	9.5	14.60	10.77	0.56	0.022	25.0
02MQ	0.0	32.0	16.04	11.83	0.61	0.024	40.0
02MW	12.5	54.5	19.61	14.46	0.71	0.028	55.0
02MA	25.0	77.0	18.85	13.90	0.71	0.028	50.0
02MB	51.0	123.8	23.89	17.62	0.84	0.033	90.0
02MO	77.0	170.6	25.26	18.63	0.86	0.034	100.0
02MX	150.0	302.0	25.58	18.87	0.97	0.038	100.0
02MY	200.0	392.0	26.94	19.87	0.94	0.037	100.0
02MP	206.9	404.4	25.20	18.59	0.97	0.038	100.0

NUMBER OF SPECIMENS: 13

SOURCE: 02_T3.1R ANALYSIS SET

Y VARIABLE: ENERGY

MODEL PARAMETERS

LOWER SHELF ENERGY [HELD FIXED]: 0.1 (J), 0.1 (FT-LB)

MID-TRANSITION TEMPERATURE: -10.2 (DEG C), 13.7 (DEG F)

TRANSITION ZONE WIDTH: 91.1 (C DEG), 163.9 (F DEG)

UPPER SHELF ENERGY: 25.7 (J), 18.9 (FT-LB)

UPPER SHELF ENERGY: 25.7 (J), 18.9 (FT-LB)

NOTE: NONE

MODEL SET NAME: 6

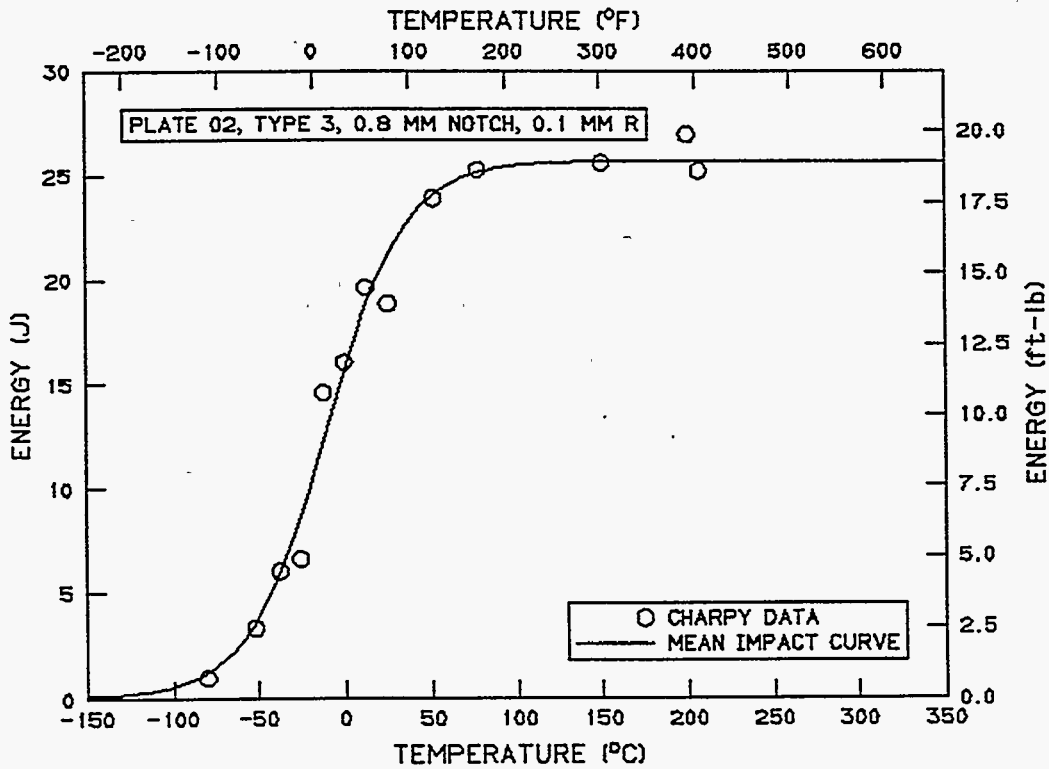

SOURCE: 02_T3.1R ANALYSIS SET

Y VARIABLE: EXPANSION

MODEL PARAMETERS

LOWER SHELF EXPANSION [HELD FIXED]: 0.000 (MM), 0.0000 (IN)

MID-TRANSITION TEMPERATURE: -11.3 (DEG C), 11.7 (DEG F)

TRANSITION ZONE WIDTH: 76.5 (C DEG), 137.7 (F DEG)

UPPER SHELF EXPANSION: 0.916 (MM), 0.0361 (IN)

UPPER SHELF EXPANSION: 0.916 (MM), 0.0361 (IN)

NOTE: NONE

MODEL SET NAME: 7

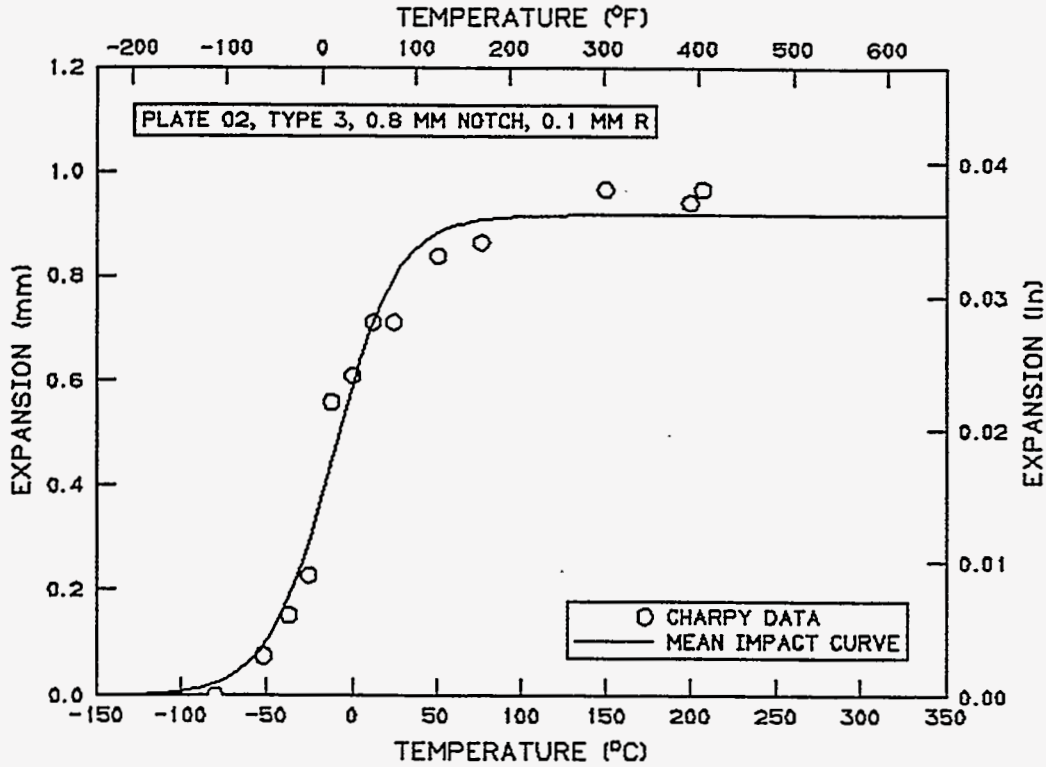

SOURCE: 02_T3.1R ANALYSIS SET

Y VARIABLE: SHEAR

MODEL PARAMETERS

LOWER SHELF SHEAR [HELD FIXED]: 0 (PERCENT)

MID-TRANSITION TEMPERATURE: 12.8 (DEG C), 55.0 (DEG F)

TRANSITION ZONE WIDTH: 88.2 (C DEG), 158.8 (F DEG)

UPPER SHELF SHEAR [HELD FIXED]: 100 (PERCENT)

UPPER SHELF SHEAR: 100 (PERCENT)

NOTE: NONE

MODEL SET NAME: 8

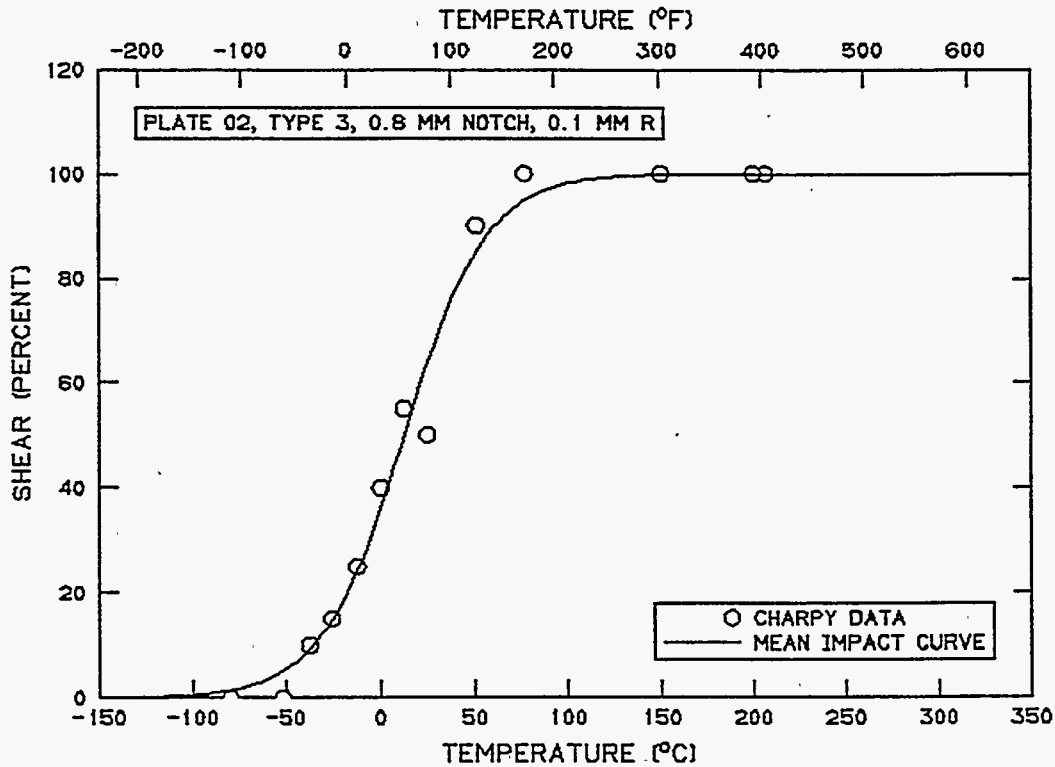

SOURCE: ANALYSIS SET
ANALYSIS SET NAME: 02_T3.FH

SET NAME: 02_T3.FH

NOTE: HSST PLATE 02, TYPE 1, 45 DEG ANGLE, 0.25 MM RAD

IDENT	TEMPERATURE		ENERGY		EXPANSION		SHEAR (PERCENT)
	(DEG C)	(DEG F)	(J)	(FT-LB)	(MM)	(IN)	
02NJ	-100.0	-148.0	2.56	1.89	0.03	0.001	0.0
02NI	-75.0	-103.0	6.59	4.86	0.18	0.007	0.0
02NH	-50.0	-58.0	11.35	8.37	0.41	0.016	10.0
02NK	-37.5	-35.5	16.65	12.28	0.69	0.027	20.0
02NG	-25.0	-13.0	16.22	11.96	0.61	0.024	15.0
02NF	0.0	32.0	23.84	17.58	0.89	0.035	60.0
02NB	25.0	77.0	21.77	16.06	0.71	0.028	65.0
02NC	50.0	122.0	30.03	22.15	1.04	0.041	80.0
02ND	75.0	167.0	27.31	20.14	0.94	0.037	100.0
02NL	150.0	302.0	30.59	22.56	1.04	0.041	100.0
02NE	200.0	392.0	32.00	23.60	0.99	0.039	100.0
02NM	200.0	392.0	31.85	23.49	0.97	0.038	100.0

NUMBER OF SPECIMENS: 12

SOURCE: 02_T3.FH ANALYSIS SET

Y VARIABLE: ENERGY

MODEL PARAMETERS

LOWER SHELF ENERGY [HELD FIXED]: 0.1 (J), 0.1 (FT-LB)

MID-TRANSITION TEMPERATURE: -31.3 (DEG C), -24.3 (DEG F)

TRANSITION ZONE WIDTH: 145.5 (C DEG), 261.9 (F DEG)

UPPER SHELF ENERGY: 31.0 (J), 22.9 (FT-LB)

UPPER SHELF ENERGY: 31.0 (J), 22.9 (FT-LB)

NOTE: NONE

MODEL SET NAME: 1

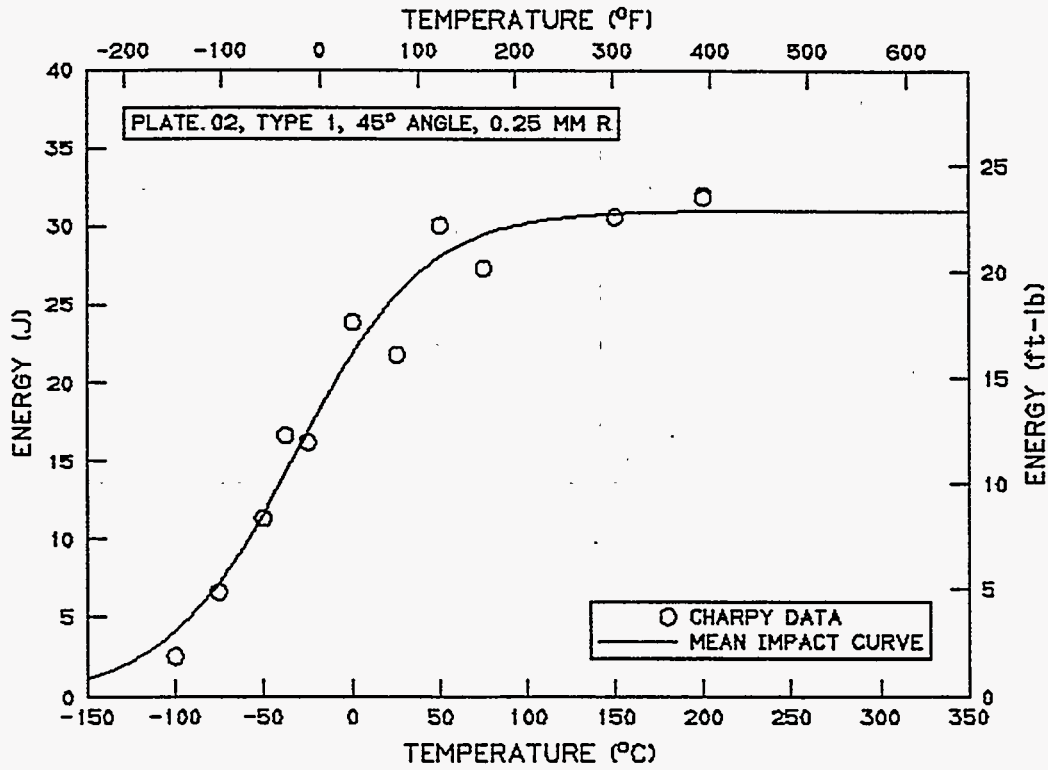

SOURCE: 02_T3.FH ANALYSIS SET

Y VARIABLE: EXPANSION

MODEL PARAMETERS

LOWER SHELF EXPANSION [HELD FIXED]: 0.000 (MM), 0.0000 (IN)

MID-TRANSITION TEMPERATURE: -44.6 (DEG C), -48.2 (DEG F)

TRANSITION ZONE WIDTH: 91.8 (C DEG), 165.3 (F DEG)

UPPER SHELF EXPANSION: 0.968 (MM), 0.0381 (IN)

UPPER SHELF EXPANSION: 0.968 (MM), 0.0381 (IN)

NOTE: NONE

MODEL SET NAME: 0

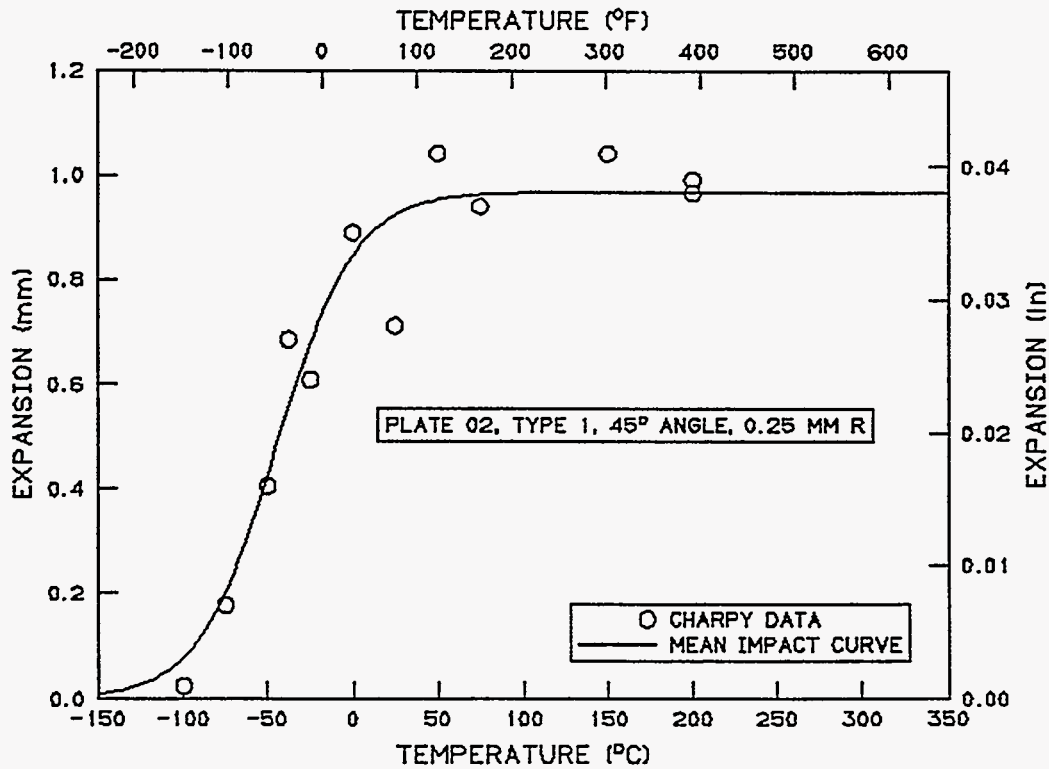

SOURCE: 02_T3.FH ANALYSIS SET

Y VARIABLE: SHEAR

MODEL PARAMETERS

LOWER SHELF SHEAR [HELD FIXED]: 0 (PERCENT)

MID-TRANSITION TEMPERATURE: 3.1 (DEG C), 37.5 (DEG F)

TRANSITION ZONE WIDTH: 100.4 (C DEG), 180.8 (F DEG)

UPPER SHELF SHEAR: 100 (PERCENT)

UPPER SHELF SHEAR: 100 (PERCENT)

NOTE: NONE

MODEL SET NAME: 9

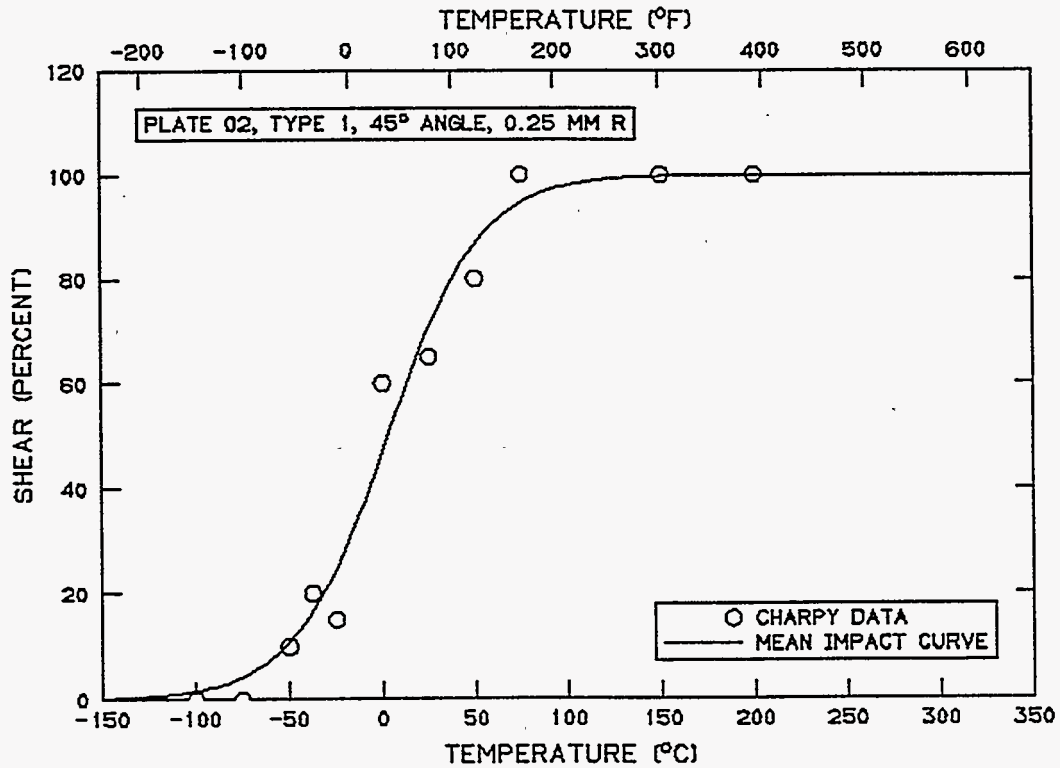

SOURCE: ANALYSIS SET
ANALYSIS SET NAME: 2HSST02_.T4

SET NAME: 2HSST02_.T4

NOTE: HSST PLATE 02, ANVIL SPAN EQUALS 20mm, SPEC. TYPE 4

IDENT	TEMPERATURE		ENERGY (J)	EXPANSION		SHEAR (PERCENT)	
	(DEG C)	(DEG F)		(FT-LB)	(MM)		(IN)
02A2	-75.0	-103.0	0.27	0.20	0.00	0.000	0.0
02A1	-62.5	-80.5	0.41	0.30	0.03	0.001	5.0
02A3	-50.0	-58.0	2.44	1.80	0.13	0.005	10.0
02C1	-50.0	-58.0	0.81	0.60	0.05	0.002	15.0
02A4	-37.5	-35.5	2.17	1.60	0.18	0.007	10.0
02A5	-25.0	-13.0	1.90	1.40	0.10	0.004	15.0
02C2	-25.0	-13.0	3.39	2.50	0.25	0.010	40.0
02A6	-12.5	9.5	2.58	1.90	0.23	0.009	35.0
02B1	0.0	32.0	4.61	3.40	0.38	0.015	60.0
02B2	12.5	54.5	5.02	3.70	0.46	0.018	80.0
02B3	25.0	77.0	5.02	3.70	0.53	0.021	80.0
02B4	37.5	99.5	6.51	4.80	0.64	0.025	100.0
0266	75.0	167.0	7.70	5.68	0.61	0.024	100.0
0265	100.0	212.0	7.10	5.24	0.64	0.025	100.0
02B5	100.0	212.0	6.78	5.00	0.69	0.027	100.0
02C3	125.0	257.0	7.10	5.24	0.56	0.022	100.0
02B6	150.0	302.0	6.51	4.80	0.61	0.024	100.0

NUMBER OF SPECIMENS: 17

SOURCE: 2HSST02_.T4 ANALYSIS SET

Y VARIABLE: ENERGY

MODEL PARAMETERS

LOWER SHELF ENERGY [HELD FIXED]: 0.1 (J), 0.1 (FT-LB)

MID-TRANSITION TEMPERATURE: -9.1 (DEG C), 15.7 (DEG F)

TRANSITION ZONE WIDTH: 102.9 (C DEG), 185.1 (F DEG)

UPPER SHELF ENERGY: 7.1 (J), 5.2 (FT-LB)

UPPER SHELF ENERGY: 7.1 (J), 5.2 (FT-LB)

NOTE: NONE

MODEL SET NAME: 3

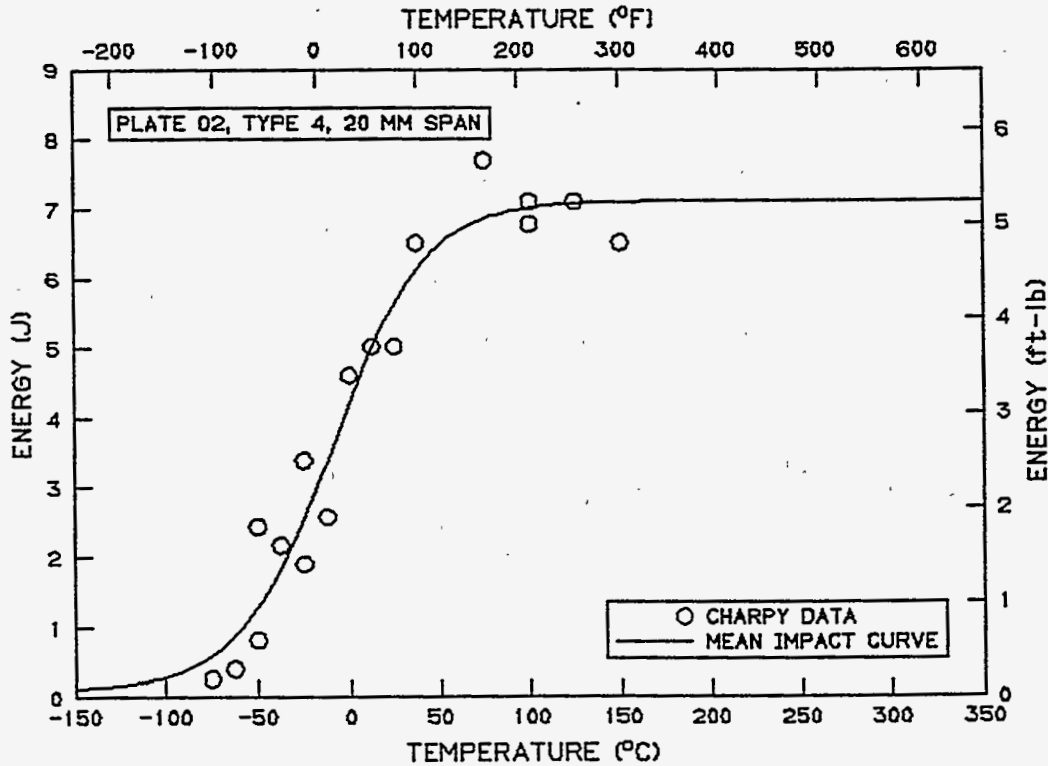

SOURCE: 2HSST02_.T4 ANALYSIS SET

Y VARIABLE: EXPANSION

MODEL PARAMETERS

LOWER SHELF EXPANSION [HELD FIXED]: 0.000 (MM), 0.0000 (IN)

MID-TRANSITION TEMPERATURE: -7.8 (DEG C), 17.9 (DEG F)

TRANSITION ZONE WIDTH: 79.7 (C DEG), 143.5 (F DEG)

UPPER SHELF EXPANSION: 0.632 (MM), 0.0249 (IN)

UPPER SHELF EXPANSION: 0.632 (MM), 0.0249 (IN)

NOTE: NONE

MODEL SET NAME: 4

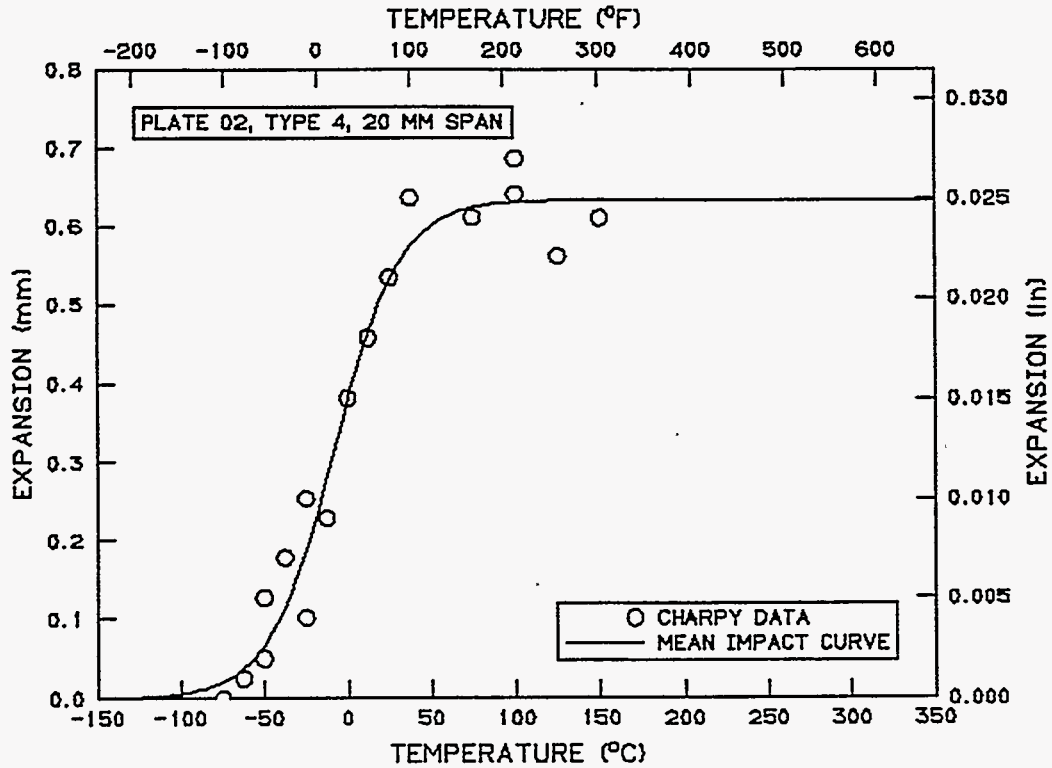

SOURCE: 2HSST02_.T4 ANALYSIS SET

Y VARIABLE: SHEAR

MODEL PARAMETERS

LOWER SHELF SHEAR [HELD FIXED]: 0 (PERCENT)

MID-TRANSITION TEMPERATURE:-6.7 (DEG C),20.0 (DEG F)

TRANSITION ZONE WIDTH: 69.1 (C DEG),124.4 (F DEG)

UPPER SHELF SHEAR [HELD FIXED]: 100 (PERCENT)

UPPER SHELF SHEAR: 100 (PERCENT)

NOTE: NONE

MODEL SET NAME: 5

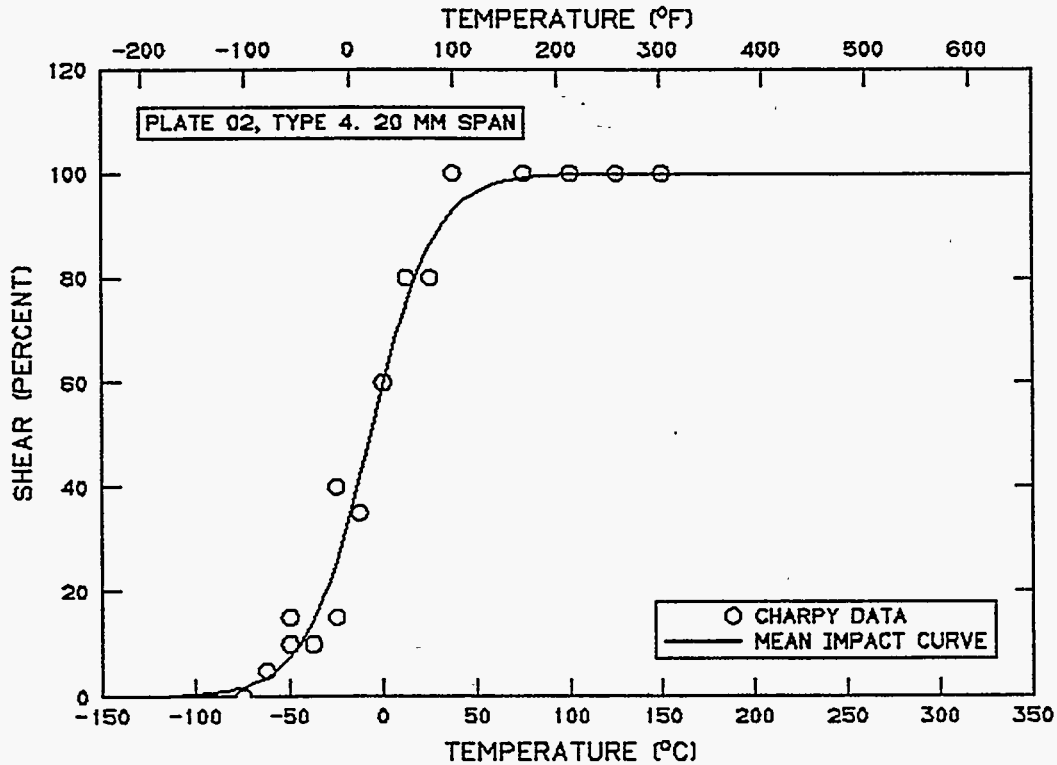

APPENDIX H
HSST PLATE 02, HALF THICKNESS,
TL ORIENTATION

SOURCE: ANALYSIS SET
 ANALYSIS SET NAME: 020_5.FUL

SET NAME: 020_5.FUL

NOTE: HSST PLATE 02 FULL-SIZE, T-L ORIENTATION, HALF-THICKNESS

IDENT	TEMPERATURE		ENERGY		EXPANSION		SHEAR (PERCENT)
	(DEG C)	(DEG F)	(J)	(FT-LB)	(MM)	(IN)	
02B-1016	-1.1	30.0	32.54	24.00	0.61	0.024	20.0
02B-1017	-1.1	30.0	31.18	23.00	0.48	0.019	20.0
02B-1019	-1.1	30.0	23.05	17.00	0.43	0.017	20.0
02B-1012	15.6	60.0	27.12	20.00	0.46	0.018	30.0
02B-1013	15.6	60.0	37.96	28.00	0.61	0.024	25.0
02B-1015	15.6	60.0	47.45	35.00	0.71	0.028	25.0
02C-1008	15.6	60.0	36.61	27.00	0.64	0.025	20.0
02C-1009	15.6	60.0	38.64	28.50	0.58	0.023	20.0
02C-1011	15.6	60.0	50.17	37.00	0.94	0.037	20.0
02C-1012	48.9	120.0	78.64	58.00	1.45	0.057	60.0
02C-1013	48.9	120.0	79.99	59.00	1.35	0.053	55.0
02C-1015	48.9	120.0	84.06	62.00	1.37	0.054	65.0
02B-1008	93.3	200.0	100.33	74.00	1.75	0.069	100.0
02B-1009	93.3	200.0	104.40	77.00	1.52	0.060	100.0
02B-1011	93.3	200.0	81.35	60.00	1.35	0.053	100.0
02C-1004	93.3	200.0	128.80	95.00	1.83	0.072	100.0
02C-1005	93.3	200.0	123.38	91.00	1.68	0.066	100.0
02C-1007	93.3	200.0	126.09	93.00	1.70	0.067	100.0
02B-1020	121.1	250.0	112.53	83.00	1.83	0.072	100.0
02B-1021	121.1	250.0	109.82	81.00	1.70	0.067	100.0
02B-1023	121.1	250.0	112.53	83.00	1.68	0.066	100.0
02B-1004	148.9	300.0	109.82	81.00	1.75	0.069	100.0
02B-1005	148.9	300.0	116.60	86.00	1.83	0.072	100.0
02B-1007	148.9	300.0	103.04	76.00	1.68	0.066	100.0
02C-1000	148.9	300.0	124.74	92.00	1.78	0.070	100.0
02C-1001	148.9	300.0	124.74	92.00	1.88	0.074	100.0
02C-1003	148.9	300.0	115.24	85.00	1.75	0.069	100.0
02B-1001	204.4	400.0	97.62	72.00	1.47	0.058	100.0
02B-1003	204.4	400.0	107.11	79.00	1.68	0.066	100.0

NUMBER OF SPECIMENS: 29

SOURCE: 020_5.FUL ANALYSIS SET

Y VARIABLE: ENERGY

MODEL PARAMETERS

LOWER SHELF ENERGY [HELD FIXED]: 2.7 (J), 2.0 (FT-LB)

MID-TRANSITION TEMPERATURE: 29.2 (DEG C), 84.6 (DEG F)

TRANSITION ZONE WIDTH: 86.4 (C DEG), 155.6 (F DEG)

UPPER SHELF ENERGY: 113.8 (J), 83.9 (FT-LB)

UPPER SHELF ENERGY: 113.8 (J), 83.9 (FT-LB)

TEMPERATURE [41 (J), 30.2 (FT-LB) ENERGY]: 15.4 (DEG C), 59.7 (DEG F)

TEMPERATURE [68 (J), 50.2 (FT-LB) ENERGY]: 36.9 (DEG C), 98.4 (DEG F)

NOTE: HSST PLATE 02, TL ORIENTATION, HALF-THICKNESS

MODEL SET NAME: 9

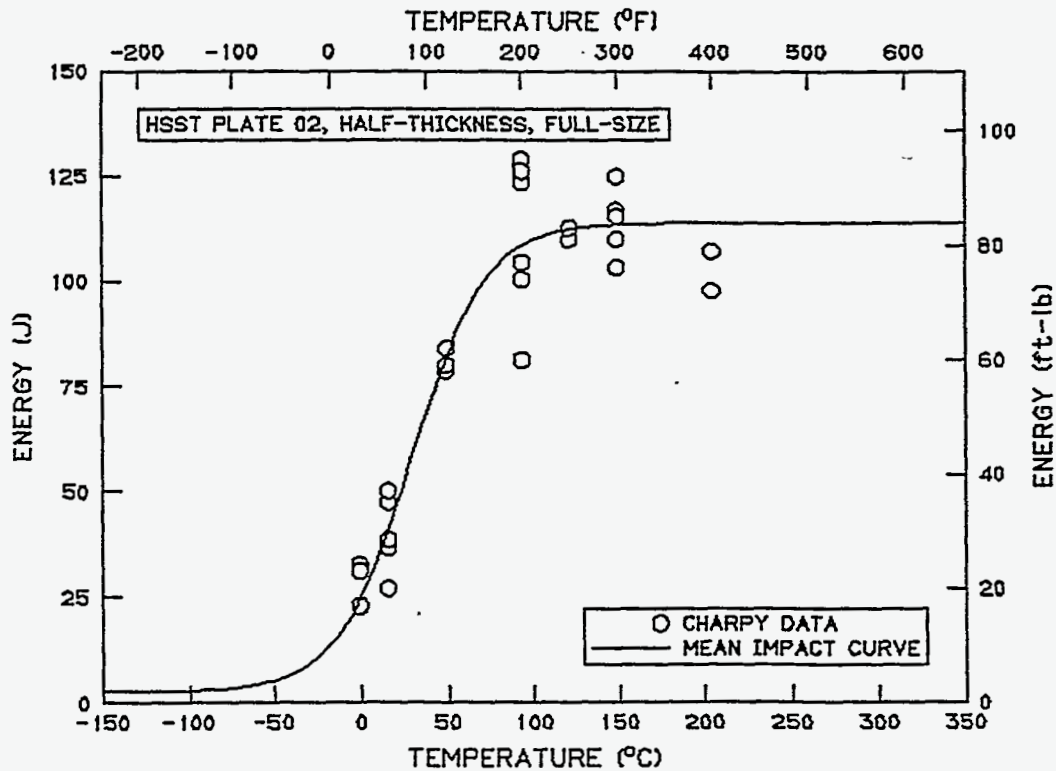

SOURCE: 020_5.FUL ANALYSIS SET

Y VARIABLE: EXPANSION

MODEL PARAMETERS

LOWER SHELF EXPANSION [HELD FIXED]: 0.000 (MM), 0.0000 (IN)

MID-TRANSITION TEMPERATURE: 23.3 (DEG C), 74.0 (DEG F)

TRANSITION ZONE WIDTH: 85.6 (C DEG), 154.0 (F DEG)

UPPER SHELF EXPANSION: 1.729 (MM), 0.0681 (IN)

UPPER SHELF EXPANSION: 1.729 (MM), 0.0681 (IN)

NOTE: NONE

MODEL SET NAME: 8

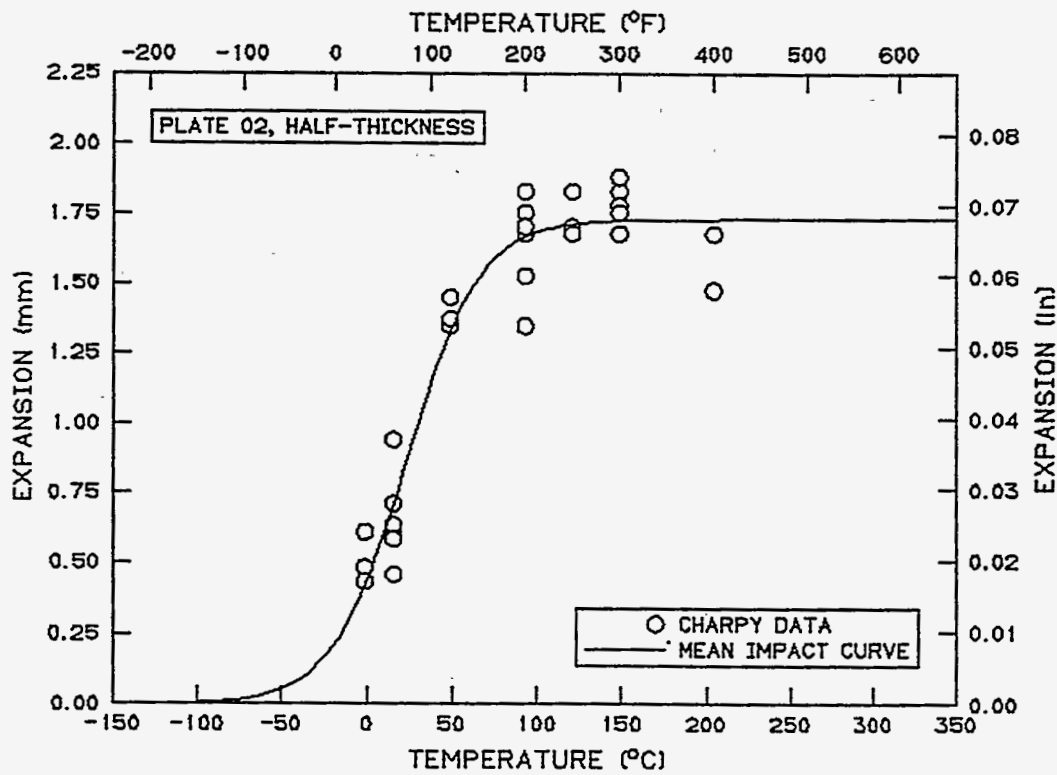

SOURCE: 020_5.FUL ANALYSIS SET

Y VARIABLE: SHEAR

MODEL PARAMETERS

LOWER SHELF SHEAR [HELD FIXED]: 0 (PERCENT)

MID-TRANSITION TEMPERATURE: 37.5 (DEG C), 99.5 (DEG F)

TRANSITION ZONE WIDTH: 78.2 (C DEG), 140.8 (F DEG)

UPPER SHELF SHEAR [HELD FIXED]: 100 (PERCENT)

UPPER SHELF SHEAR: 100 (PERCENT)

NOTE: NONE

MODEL SET NAME: 7

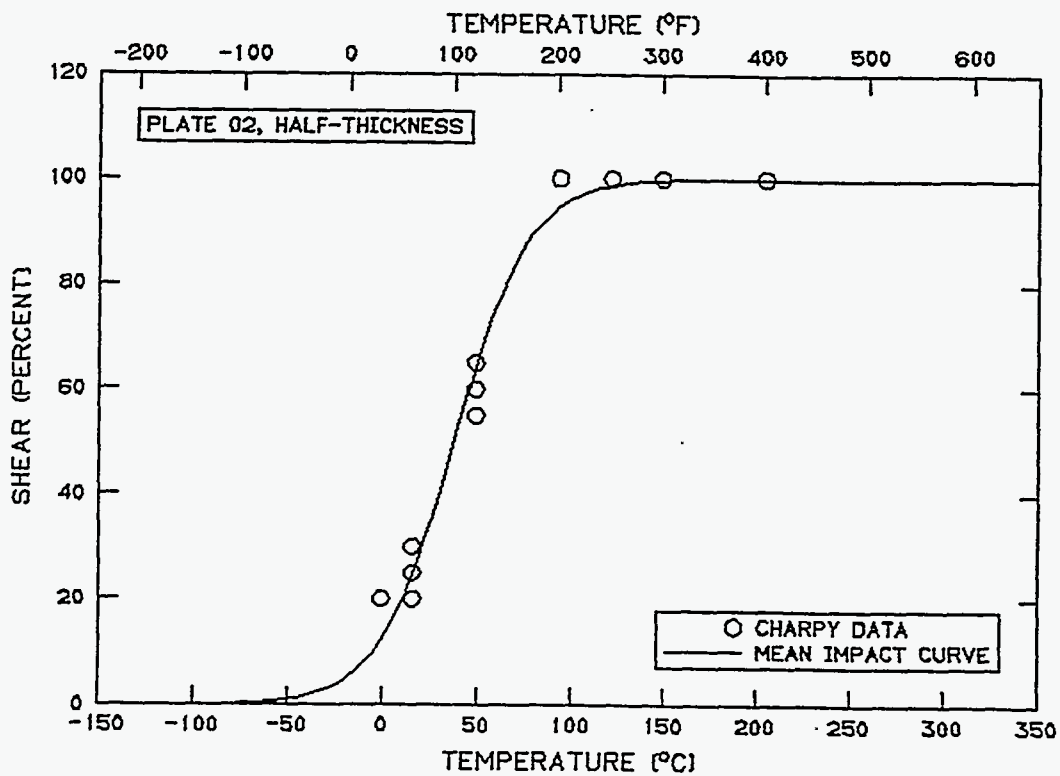

SOURCE: ANALYSIS SET
ANALYSIS SET NAME: 02_T3_12

SET NAME: 02_T3_12

NOTE: HSST PLATE 02 - TYPE 3 SPEC., HALF-THICKNESS

IDENT	TEMPERATURE		ENERGY		EXPANSION		SHEAR (PERCENT)
	(DEG C)	(DEG F)	(J)	(FT-LB)	(MM)	(IN)	
2B06B	-87.5	-125.5	0.95	0.70	0.00	0.000	0.0
2B06A	-75.0	-103.0	2.58	1.90	0.00	0.000	0.0
2B02B	-62.5	-80.5	2.85	2.10	0.05	0.002	5.0
2B02A	-50.0	-58.0	4.20	3.10	0.10	0.004	15.0
2B10A	-37.5	-35.5	6.91	5.10	0.18	0.007	20.0
2B10B	-25.0	-13.0	8.81	6.50	0.30	0.012	35.0
2B14A	-12.5	9.5	9.08	6.70	0.33	0.013	40.0
2B14B	0.0	32.0	10.71	7.90	0.48	0.019	60.0
2C14A	12.5	54.5	12.34	9.10	0.53	0.021	75.0
2C02B	25.0	77.0	18.71	13.80	0.79	0.031	85.0
2C02A	50.0	122.0	19.12	14.10	0.71	0.028	100.0
2C14B	62.5	144.5	21.56	15.90	0.89	0.035	95.0
2B18A	100.0	212.0	18.98	14.00	0.99	0.039	100.0
2B18B	200.0	392.0	18.57	13.70	0.46	0.018	100.0

NUMBER OF SPECIMENS: 14

SOURCE: 02_T3_12 ANALYSIS SET

Y VARIABLE: ENERGY

MODEL PARAMETERS

LOWER SHELF ENERGY [HELD FIXED]: 0.1 (J), 0.1 (FT-LB)

MID-TRANSITION TEMPERATURE: -12.2 (DEG C), 10.1 (DEG F)

TRANSITION ZONE WIDTH: 108.3 (C DEG), 195.0 (F DEG)

UPPER SHELF ENERGY: 20.3 (J), 15.0 (FT-LB)

UPPER SHELF ENERGY: 20.3 (J), 15.0 (FT-LB)

NOTE: PLATE 02, HALF-THICKNESS

MODEL SET NAME: 4

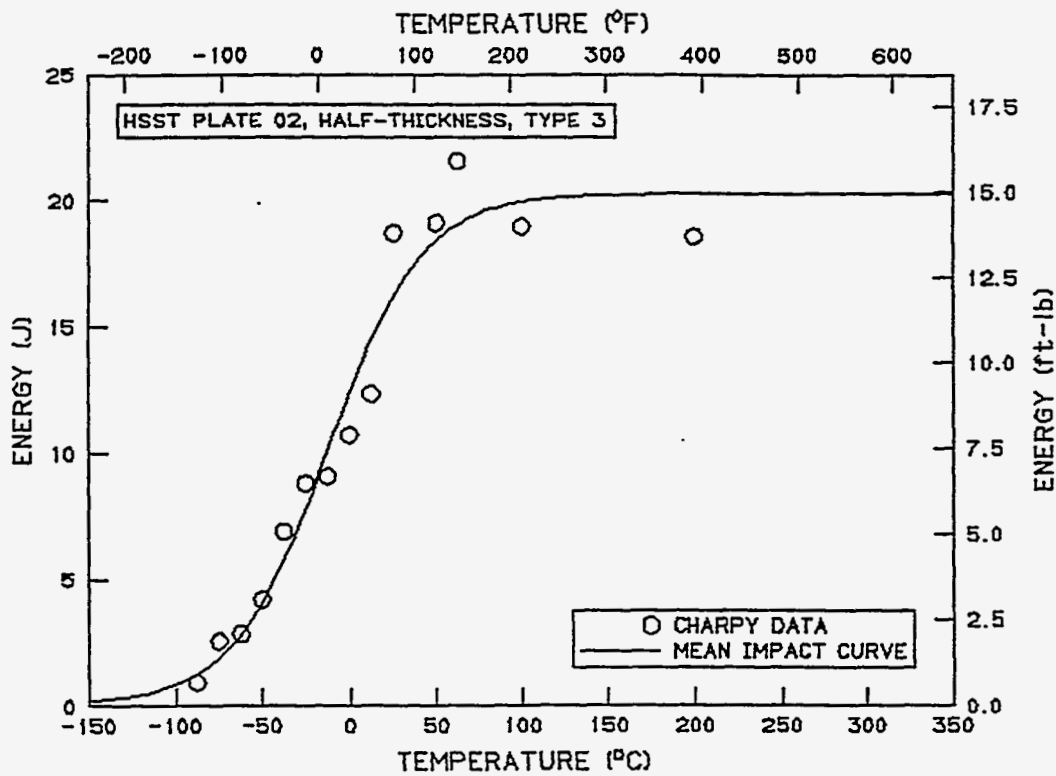

SOURCE: 02_T3_12 ANALYSIS SET

Y VARIABLE: EXPANSION

MODEL PARAMETERS

LOWER SHELF EXPANSION [HELD FIXED]: 0.000 (MM), 0.0000 (IN)

MID-TRANSITION TEMPERATURE: -11.3 (DEG C), 11.7 (DEG F)

TRANSITION ZONE WIDTH: 75.2 (C DEG), 135.3 (F DEG)

UPPER SHELF EXPANSION: 0.779 (MM), 0.0307 (IN)

UPPER SHELF EXPANSION: 0.779 (MM), 0.0307 (IN)

NOTE: NONE

MODEL SET NAME: 5

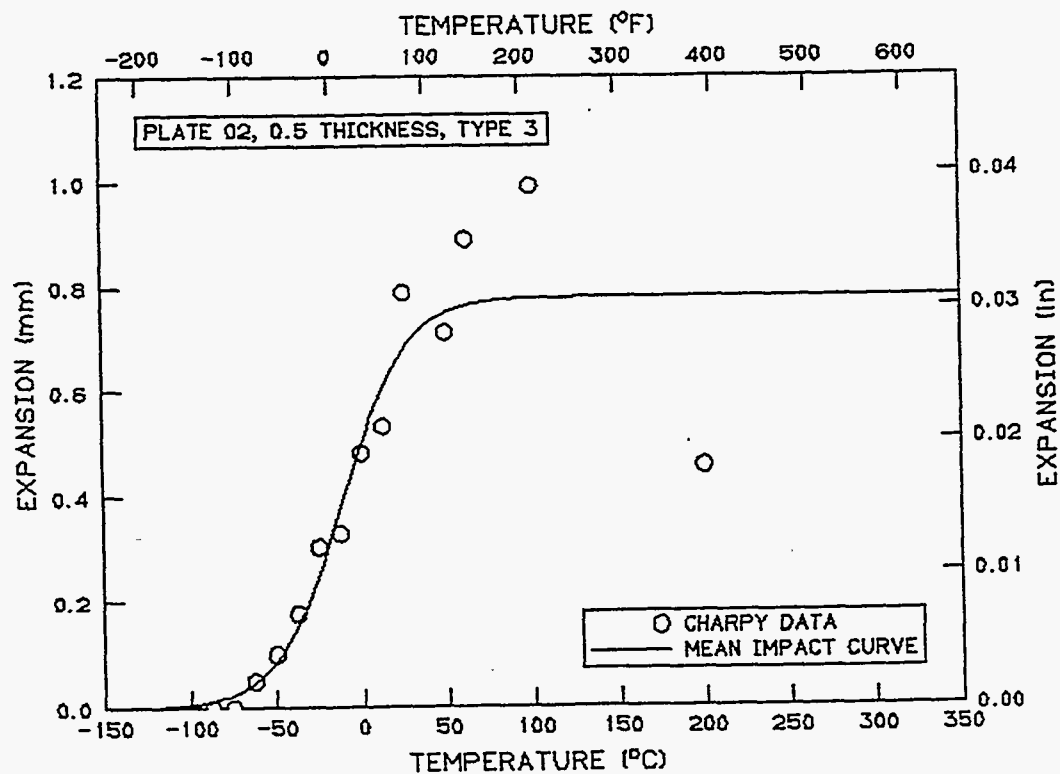

SOURCE: 02_T3_12 ANALYSIS SET

Y VARIABLE: SHEAR

MODEL PARAMETERS

LOWER SHELF SHEAR [HELD FIXED]: 0 (PERCENT)

MID-TRANSITION TEMPERATURE:-8.8 (DEG C),16.2 (DEG F)

TRANSITION ZONE WIDTH: 80.0 (C DEG),143.9 (F DEG)

UPPER SHELF SHEAR [HELD FIXED]: 100 (PERCENT)

UPPER SHELF SHEAR: 100 (PERCENT)

NOTE: NONE

MODEL SET NAME: 6

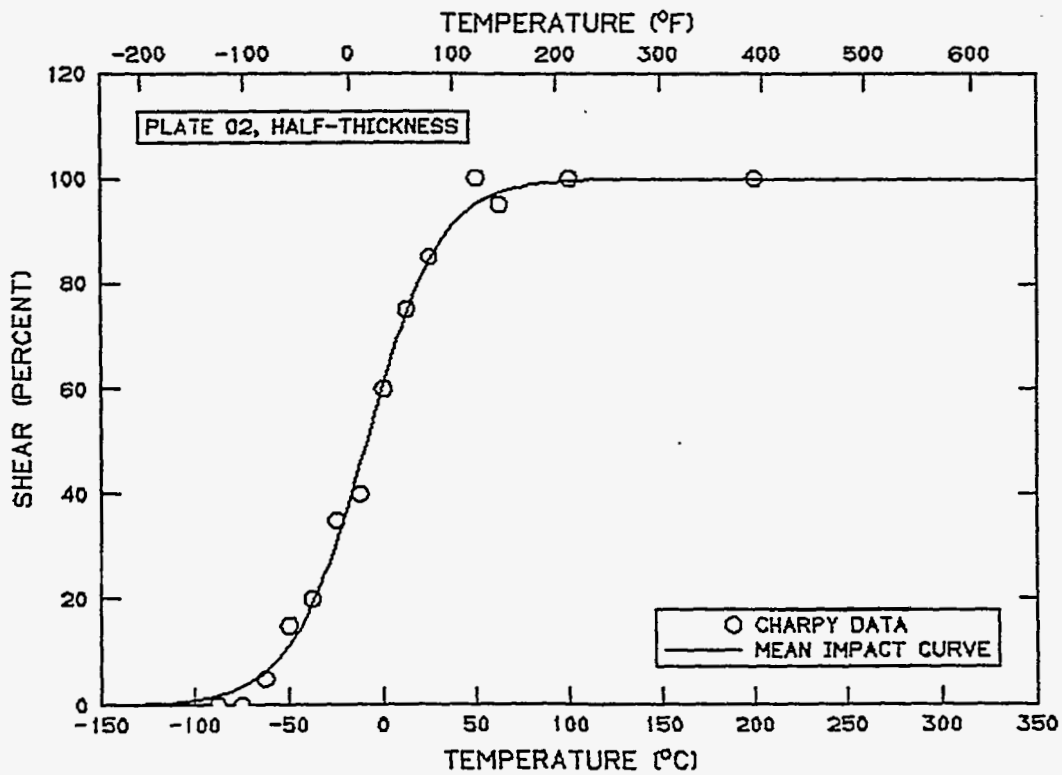

SOURCE: ANALYSIS SET
ANALYSIS SET NAME: 02_TYPE_.5

SET NAME: 02_TYPE_.5
NOTE: HSST 02 - SPECIMEN TYPE 5

IDENT	TEMPERATURE		ENERGY (J)	(FT-LB)	EXPANSION		SHEAR (PERCENT)
	(DEG C)	(DEG F)			(MM)	(IN)	
2B14	-75.0	-103.0	1.36	1.00	0.23	0.009	0.0
2B10	-50.0	-58.0	3.66	2.70	0.18	0.007	0.0
2C14	-37.5	-35.5	6.91	5.10	0.36	0.014	15.0
2B18	-25.0	-13.0	8.41	6.20	0.48	0.019	30.0
2B02	0.0	32.0	12.88	9.50	0.76	0.030	45.0
2B06	25.0	77.0	15.05	11.10	0.81	0.032	70.0
2C02	50.0	122.0	20.07	14.80	1.02	0.040	90.0
2B22	75.0	167.0	16.68	12.30	0.99	0.039	100.0
2C06	100.0	212.0	22.24	16.40	1.02	0.040	100.0
2C10	150.0	302.0	19.52	14.40	1.04	0.041	100.0

NUMBER OF SPECIMENS: 10

SOURCE: 02_TYPE_5 ANALYSIS SET

Y VARIABLE: ENERGY

MODEL PARAMETERS

LOWER SHELF ENERGY [HELD FIXED]: 0.1 (J), 0.1 (FT-LB)

MID-TRANSITION TEMPERATURE: -14.1 (DEG C), 6.6 (DEG F)

TRANSITION ZONE WIDTH: 109.2 (C DEG), 196.6 (F DEG)

UPPER SHELF ENERGY: 20.1 (J), 14.9 (FT-LB)

UPPER SHELF ENERGY: 20.1 (J), 14.9 (FT-LB)

NOTE: NONE

MODEL SET NAME: 0

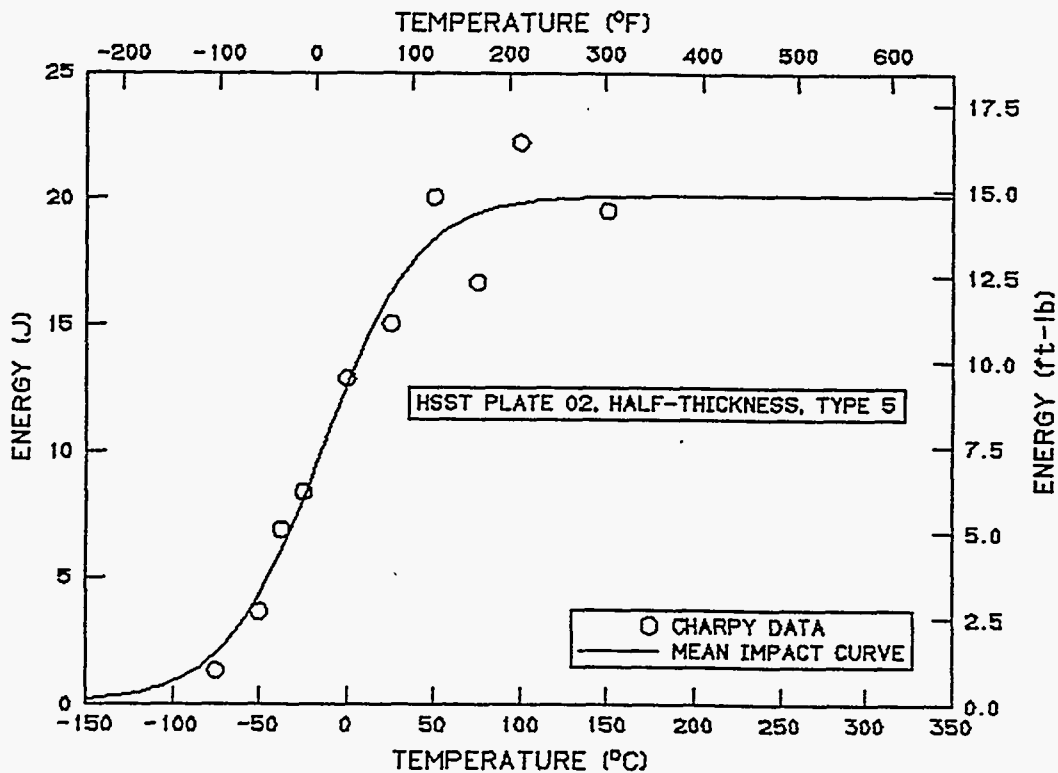

SOURCE: 02_TYPE_5 ANALYSIS SET

Y VARIABLE: EXPANSION

MODEL PARAMETERS

LOWER SHELF EXPANSION [HELD FIXED]: 0.000 (MM), 0.0000 (IN)

MID-TRANSITION TEMPERATURE: -20.6 (DEG C), -5.0 (DEG F)

TRANSITION ZONE WIDTH: 110.4 (C DEG), 198.7 (F DEG)

UPPER SHELF EXPANSION: 1.040 (MM), 0.0409 (IN)

UPPER SHELF EXPANSION: 1.040 (MM), 0.0409 (IN)

NOTE: NONE

MODEL SET NAME: 1

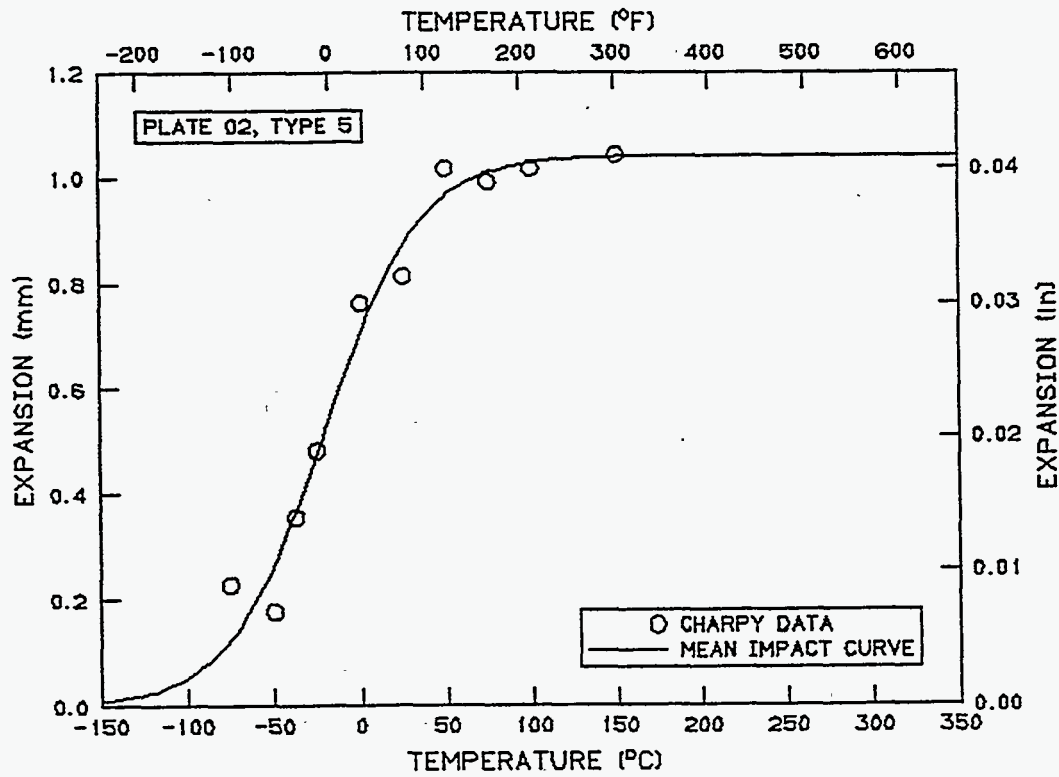

SOURCE: 02_TYPE_.5 ANALYSIS SET

Y VARIABLE: SHEAR

MODEL PARAMETERS

LOWER SHELF SHEAR [HELD FIXED]: 0 (PERCENT)

MID-TRANSITION TEMPERATURE: 3.0 (DEG C), 37.4 (DEG F)

TRANSITION ZONE WIDTH: 88.8 (C DEG), 159.8 (F DEG)

UPPER SHELF SHEAR [HELD FIXED]: 100 (PERCENT)

UPPER SHELF SHEAR: 100 (PERCENT)

NOTE: NONE

MODEL SET NAME: 2

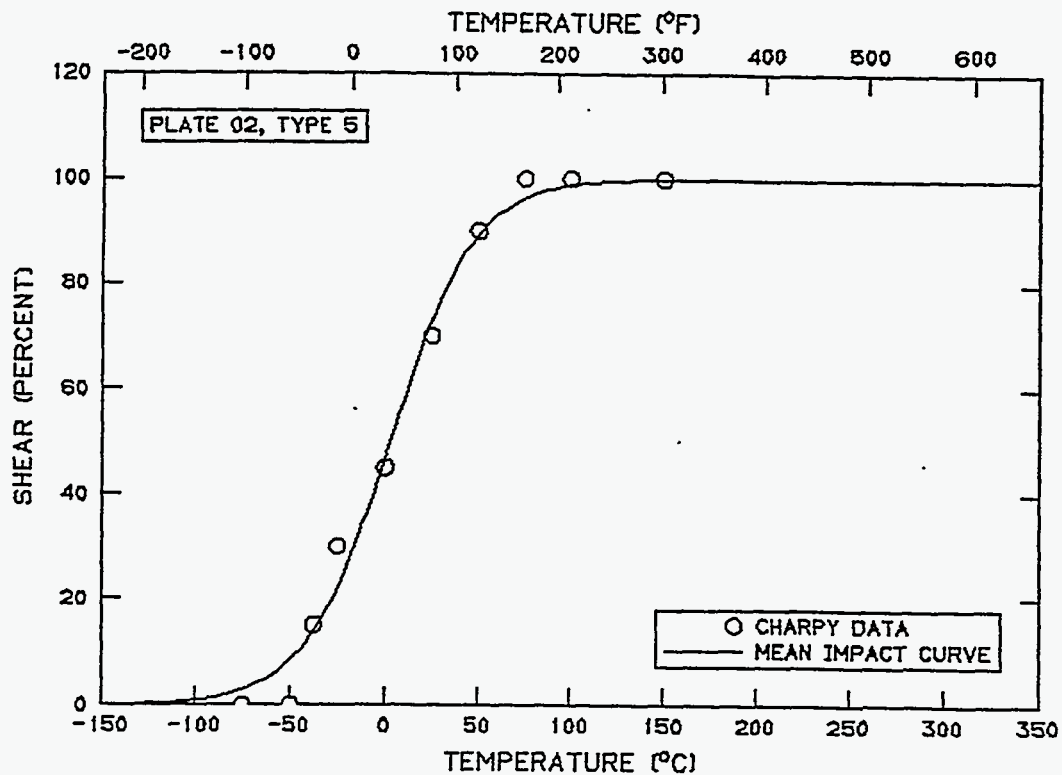

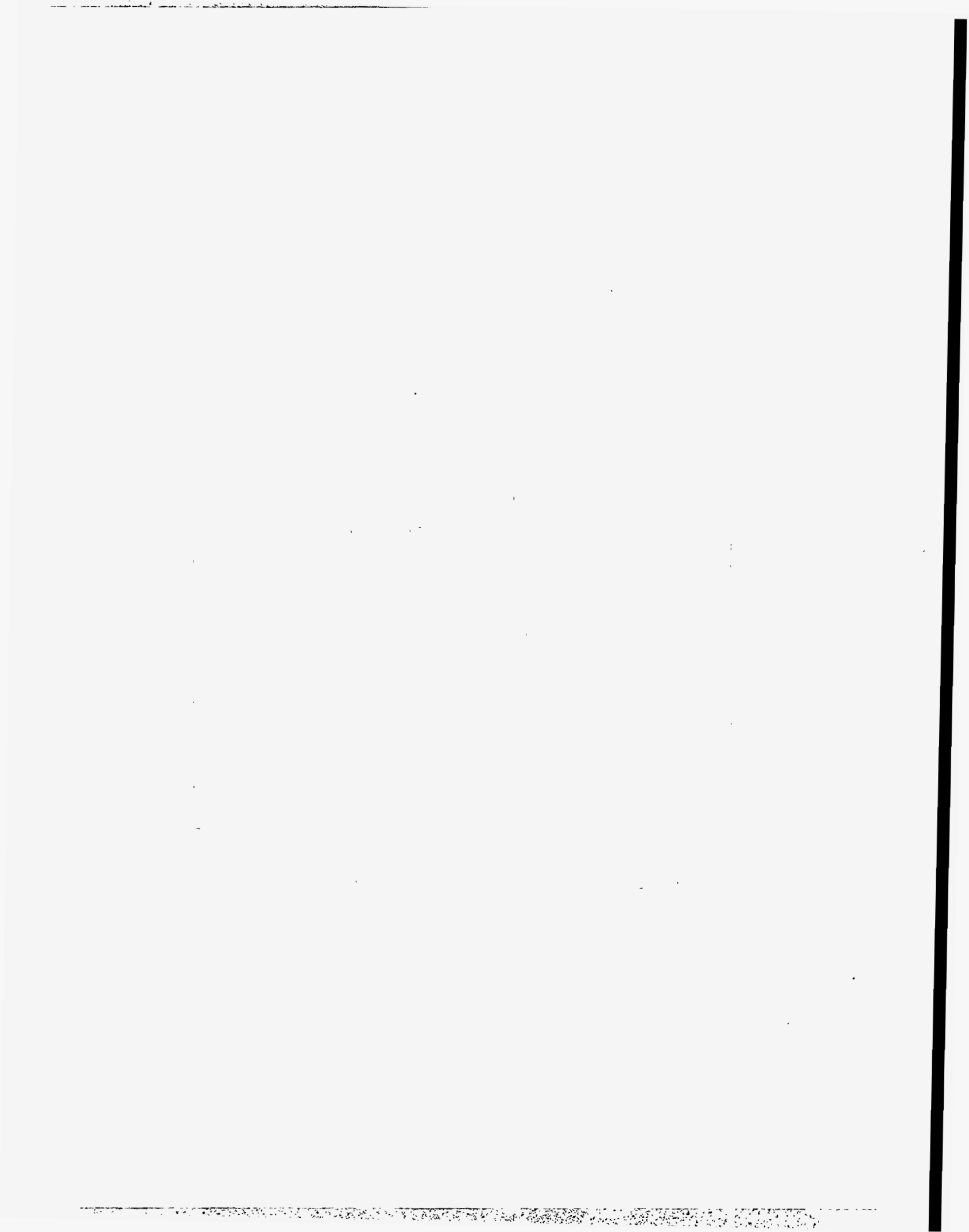

APPENDIX I

HSST PLATE 14,
QUENCHED AND TEMPERED AT 950°C

SOURCE: ANALYSIS SET
ANALYSIS SET NAME: 14AS

SET NAME: 14AS

NOTE: PLATE 014 QUENCHED, TEMPERED 950 C/5hr. FROM BLOCK SURFACE

IDENT	TEMPERATURE		ENERGY		EXPANSION		SHEAR (PERCENT)
	(DEG C)	(DEG F)	(J)	(FT-LB)	(MM)	(IN)	
A1413	-100.0	-148.0	10.03	7.40	0.05	0.002	0.0
A1462	-75.0	-103.0	22.37	16.50	0.20	0.008	10.0
A1414	-50.0	-58.0	29.29	21.60	0.30	0.012	15.0
A1466	-50.0	-58.0	34.17	25.20	0.33	0.013	15.0
A1412	-25.0	-13.0	39.32	29.00	0.43	0.017	25.0
A1461	0.0	32.0	58.44	43.10	0.66	0.026	55.0
A1465	0.0	32.0	60.74	44.80	0.69	0.027	70.0
A1411	25.0	77.0	66.71	49.20	0.79	0.031	60.0
A1463	50.0	122.0	73.89	54.50	0.97	0.038	100.0
A1415	75.0	167.0	71.99	53.10	0.99	0.039	99.0
A1464	100.0	212.0	72.81	53.70	0.94	0.037	100.0
A1416	150.0	302.0	67.52	49.80	0.97	0.038	100.0

NUMBER OF SPECIMENS: 12

SOURCE: 14AS ANALYSIS SET

Y VARIABLE: ENERGY

MODEL PARAMETERS

LOWER SHELF ENERGY [HELD FIXED]: 2.7 (J), 2.0 (FT-LB)

MID-TRANSITION TEMPERATURE: -38.9 (DEG C), -38.0 (DEG F)

TRANSITION ZONE WIDTH: 118.6 (C DEG), 213.5 (F DEG)

UPPER SHELF ENERGY: 73.0 (J), 53.8 (FT-LB)

UPPER SHELF ENERGY: 73.0 (J), 53.8 (FT-LB)

TEMPERATURE [41 (J), 30.2 (FT-LB) ENERGY]: -33.6 (DEG C), -28.4 (DEG F)

TEMPERATURE [68 (J), 50.2 (FT-LB) ENERGY]: 37.4 (DEG C), 99.4 (DEG F)

NOTE: PLATE 14 QUENCHED AND TEMPERED @ 950C/5hr FROM BLOCK SURFACE

MODEL SET NAME: 2

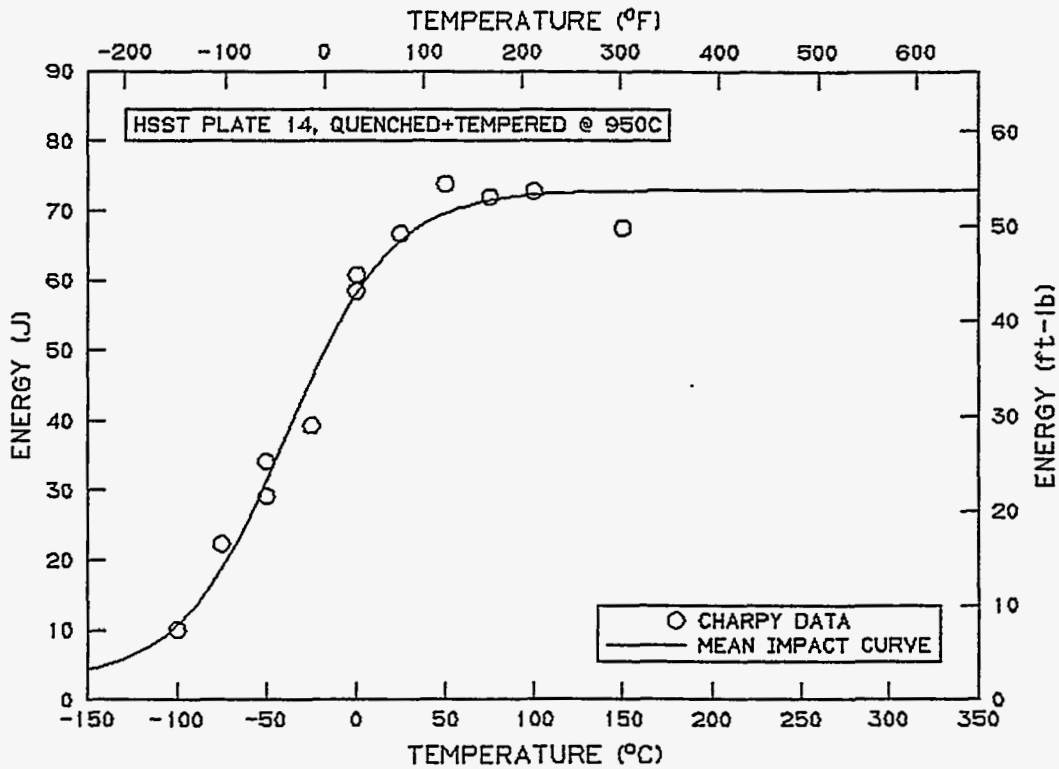

SOURCE: 14AS ANALYSIS SET

Y VARIABLE: EXPANSION

MODEL PARAMETERS

LOWER SHELF EXPANSION [HELD FIXED]: 0.061 (MM), 0.0024 (IN)

MID-TRANSITION TEMPERATURE: -18.6 (DEG C), -1.4 (DEG F)

TRANSITION ZONE WIDTH: 114.6 (C DEG), 206.3 (F DEG)

UPPER SHELF EXPANSION: 0.988 (MM), 0.0389 (IN)

UPPER SHELF EXPANSION: 0.988 (MM), 0.0389 (IN)

NOTE: NONE

MODEL SET NAME: 3

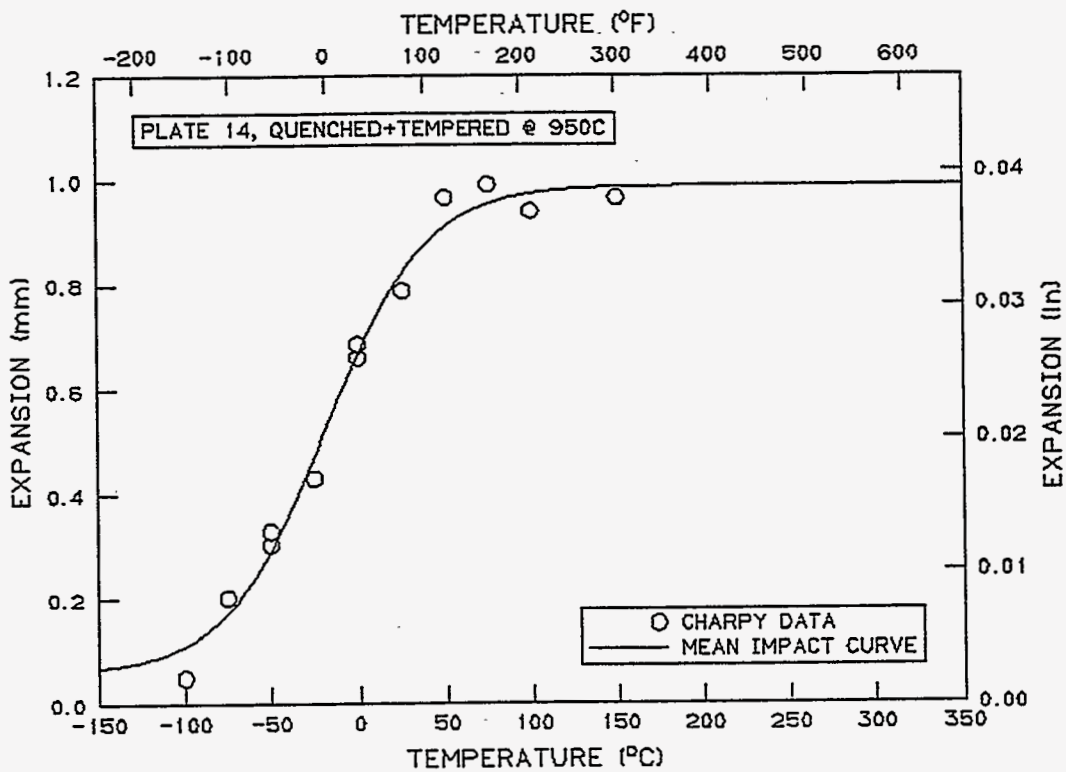

SOURCE: 14AS ANALYSIS SET

Y VARIABLE: SHEAR

MODEL PARAMETERS

LOWER SHELF SHEAR [HELD FIXED]: 0 (PERCENT)

MID-TRANSITION TEMPERATURE:-5.9 (DEG C),21.4 (DEG F)

TRANSITION ZONE WIDTH: 100.7 (C DEG),181.2 (F DEG)

UPPER SHELF SHEAR [HELD FIXED]: 100 (PERCENT)

UPPER SHELF SHEAR: 100 (PERCENT)

NOTE: NONE

MODEL SET NAME: 4

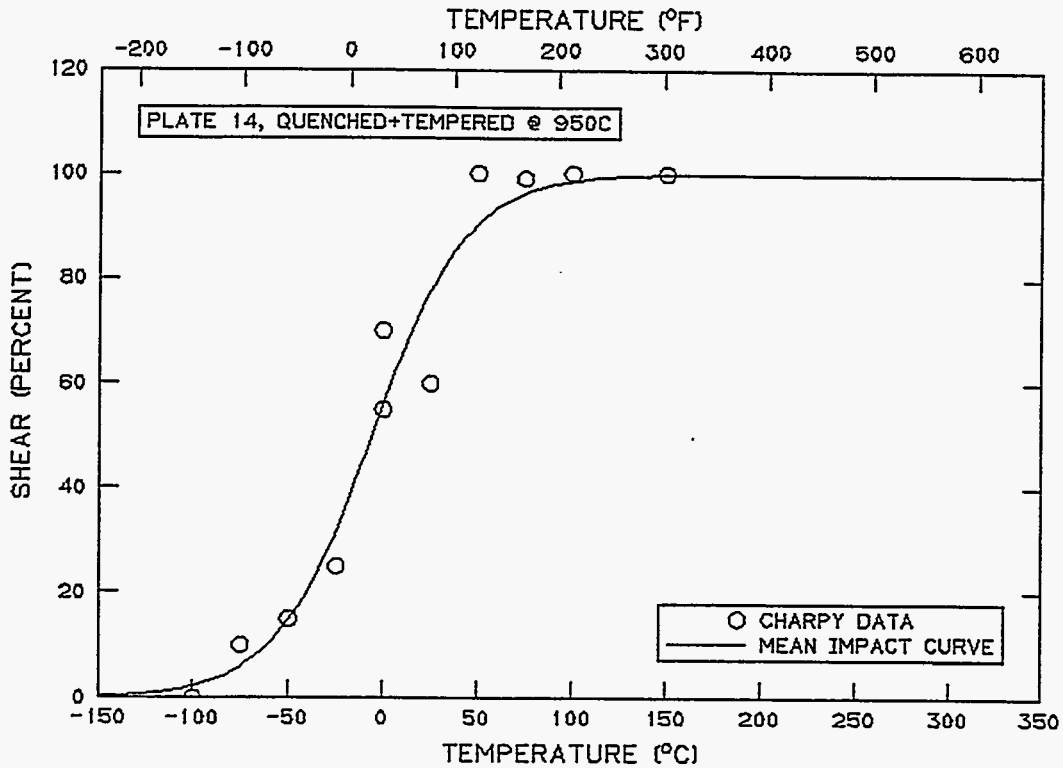

SOURCE: ANALYSIS SET
ANALYSIS SET NAME: P_14_T1

SET NAME: P 14 T1

NOTE: SUB-SIZE CORRELATION PROGRAM, TYPE 1 SPEC., PLATE 14

IDENT	TEMPERATURE		ENERGY	EXPANSION			SHEAR
	(DEG C)	(DEG F)	(J)	(FT-LB)	(MM)	(IN)	(PERCENT)
A404	-150.0	-238.0	1.65	1.22	0.00	0.000	0.0
A405	-125.0	-193.0	2.56	1.89	0.00	0.000	0.0
A406	-112.5	-170.5	1.38	1.02	0.00	0.000	UNKNOWN
A403	-100.0	-148.0	4.77	3.52	0.03	0.001	UNKNOWN
A407	-75.0	-103.0	5.99	4.42	0.00	0.000	10.0
A402	-50.0	-58.0	8.01	5.91	0.18	0.007	UNKNOWN
A408	-25.0	-13.0	11.38	8.39	0.30	0.012	UNKNOWN
A401	0.0	32.0	14.30	10.55	0.43	0.017	90.0
A410	50.0	122.0	14.85	10.95	0.46	0.018	UNKNOWN
A409	100.0	212.0	15.74	11.61	0.56	0.022	100.0
A411	200.0	392.0	13.69	10.10	0.51	0.020	100.0

NUMBER OF SPECIMENS: 11

SOURCE: P_14_T1 ANALYSIS SET

Y VARIABLE: ENERGY

MODEL PARAMETERS

LOWER SHELF ENERGY [HELD FIXED]: 0.1 (J), 0.1 (FT-LB)

MID-TRANSITION TEMPERATURE: -61.7 (DEG C), -79.1 (DEG F)

TRANSITION ZONE WIDTH: 129.0 (C DEG), 232.2 (F DEG)

UPPER SHELF ENERGY: 15.1 (J), 11.1 (FT-LB)

UPPER SHELF ENERGY: 15.1 (J), 11.1 (FT-LB)

NOTE: HSST PLATE 14, TYPE 1

MODEL SET NAME: 8

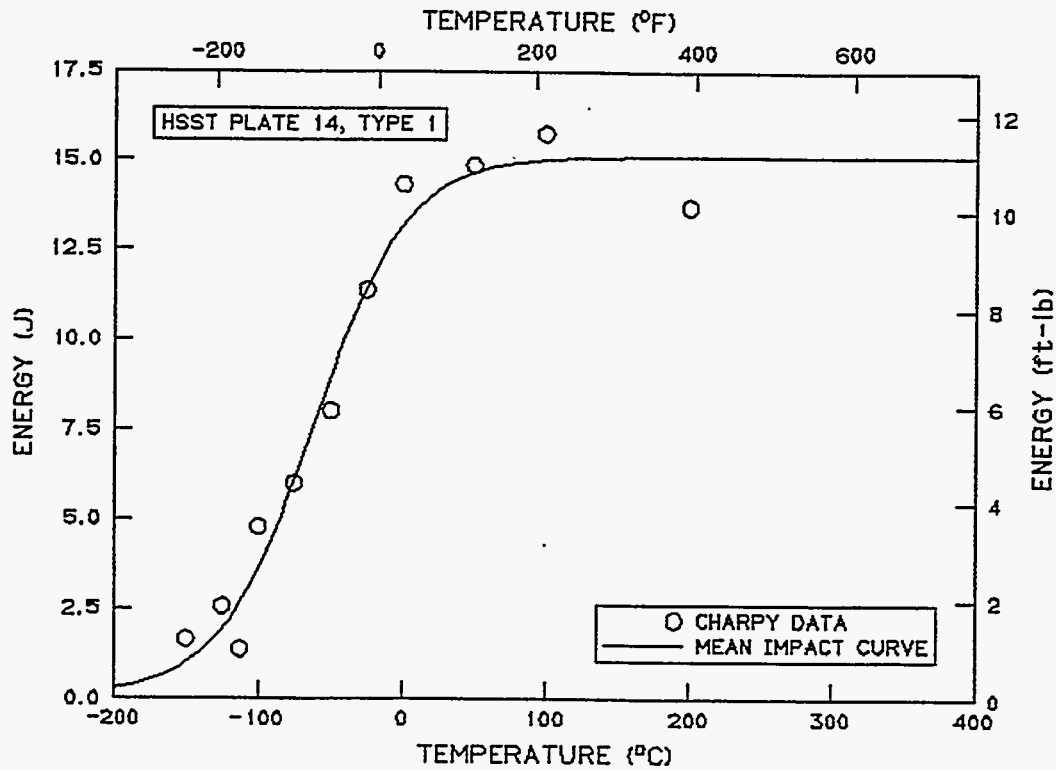

SOURCE: P_14_T1 ANALYSIS SET

Y VARIABLE: EXPANSION

MODEL PARAMETERS

LOWER SHELF EXPANSION [HELD FIXED]: 0.000 (MM), 0.0000 (IN)

MID-TRANSITION TEMPERATURE: -33.2 (DEG C), -27.7 (DEG F)

TRANSITION ZONE WIDTH: 74.8 (C DEG), 134.6 (F DEG)

UPPER SHELF EXPANSION: 0.510 (MM), 0.0201 (IN)

UPPER SHELF EXPANSION: 0.510 (MM), 0.0201 (IN)

NOTE: HSST PLATE 14, TYPE 1

MODEL SET NAME: 9

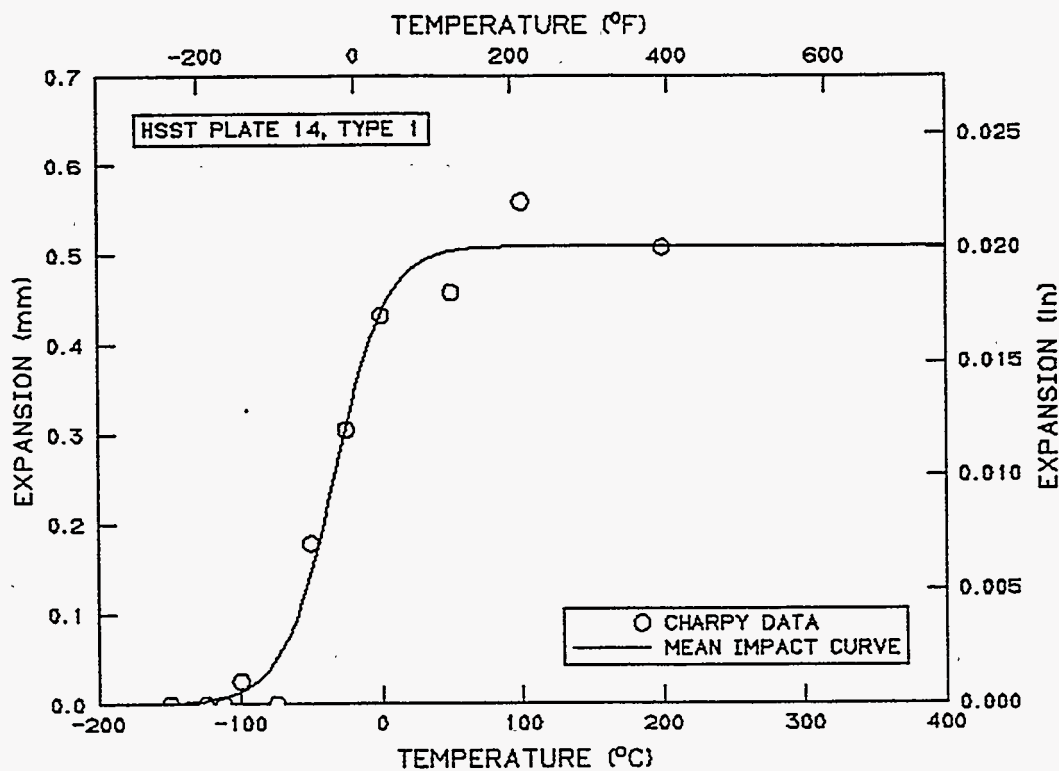

SOURCE: P_14_T1 ANALYSIS SET

Y VARIABLE: SHEAR

MODEL PARAMETERS

LOWER SHELF SHEAR [HELD FIXED]: 0 (PERCENT)
MID-TRANSITION TEMPERATURE:-37.5 (DEG C),-35.4 (DEG F)
TRANSITION ZONE WIDTH: 68.1 (C DEG),122.6 (F DEG)
UPPER SHELF SHEAR [HELD FIXED]: 100 (PERCENT)
UPPER SHELF SHEAR: 100 (PERCENT)
TEMPERATURE [50 (PERCENT),50 (PERCENT) SHEAR]:-37.5 (DEG C),-35.4 (DEG F)
NOTE: HSST PLATE 14, TYPE 1
MODEL SET NAME: 0

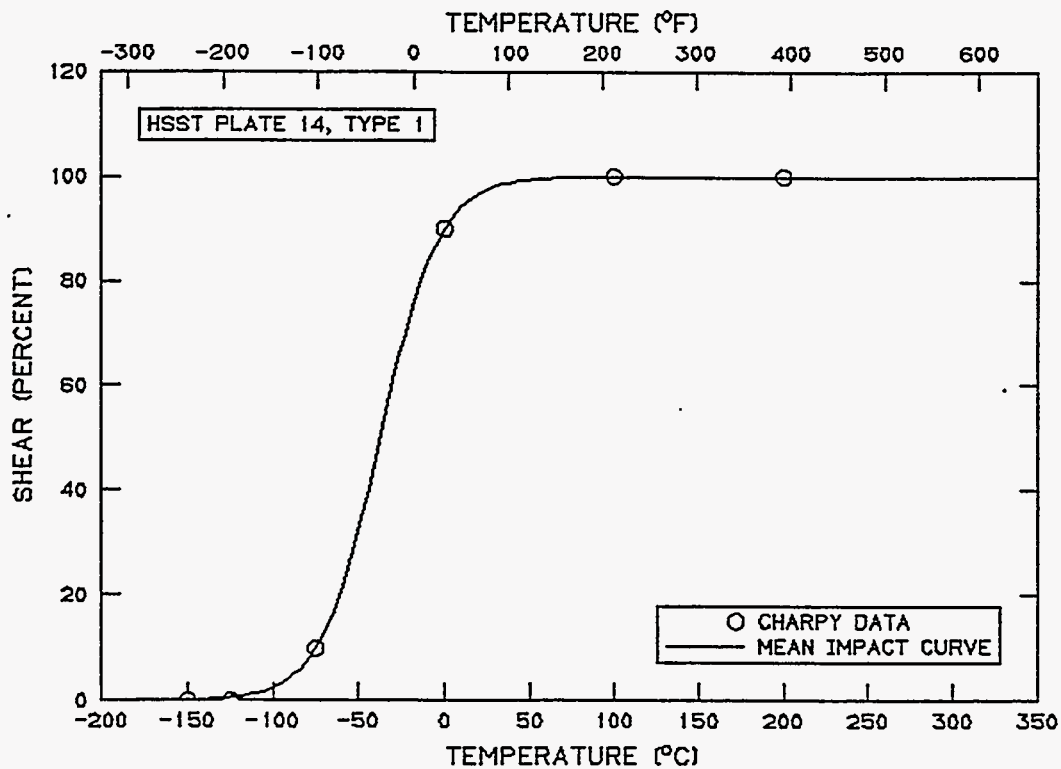

SOURCE: ANALYSIS SET
ANALYSIS SET NAME: P_14_T2

SET NAME: P_14_T2

NOTE: SUB-SIZE CORRELATION PROGRAM, PLATE 14, TYPE 2 SPECIMEN

IDENT	TEMPERATURE		ENERGY		EXPANSION		SHEAR (PERCENT)
	(DEG C)	(DEG F)	(J)	(FT-LB)	(MM)	(IN)	
A421	-150.0	-238.0	0.99	0.73	0.00	0.000	0.0
A420	-125.0	-193.0	1.98	1.46	0.00	0.000	0.0
A422	-112.5	-170.5	1.78	1.31	0.00	0.000	0.0
A419	-100.0	-148.0	1.98	1.46	0.00	0.000	15.0
A423	-87.5	-125.5	2.56	1.89	0.00	0.000	10.0
A418	-75.0	-103.0	3.93	2.90	0.13	0.005	40.0
A424	-62.5	-80.5	1.84	1.36	0.00	0.000	60.0
A417	-50.0	-58.0	4.12	3.04	0.15	0.006	70.0
A425	-37.5	-35.5	5.03	3.71	0.23	0.009	45.0
A416	-25.0	-13.0	4.58	3.38	0.15	0.006	100.0
A426	-12.5	9.5	5.55	4.09	0.23	0.009	UNKNOWN
A415	0.0	32.0	4.77	3.52	0.23	0.009	100.0
A413	25.0	77.0	5.29	3.90	0.28	0.011	100.0
A414	100.0	212.0	5.92	4.37	0.36	0.014	100.0
A428	150.0	302.0	5.22	3.85	0.25	0.010	100.0
A427	200.0	392.0	5.29	3.90	0.33	0.013	100.0

NUMBER OF SPECIMENS: 16

SOURCE: P_14_T2 ANALYSIS SET

Y VARIABLE: ENERGY

MODEL PARAMETERS

LOWER SHELF ENERGY [HELD FIXED]: 0.1 (J), 0.1 (FT-LB)

MID-TRANSITION TEMPERATURE: -83.3 (DEG C), -118.0 (DEG F)

TRANSITION ZONE WIDTH: 150.2 (C DEG), 270.4 (F DEG)

UPPER SHELF ENERGY: 5.6 (J), 4.1 (FT-LB)

UPPER SHELF ENERGY: 5.6 (J), 4.1 (FT-LB)

NOTE: HSST PLATE 14, TYPE 2

MODEL SET NAME: 3

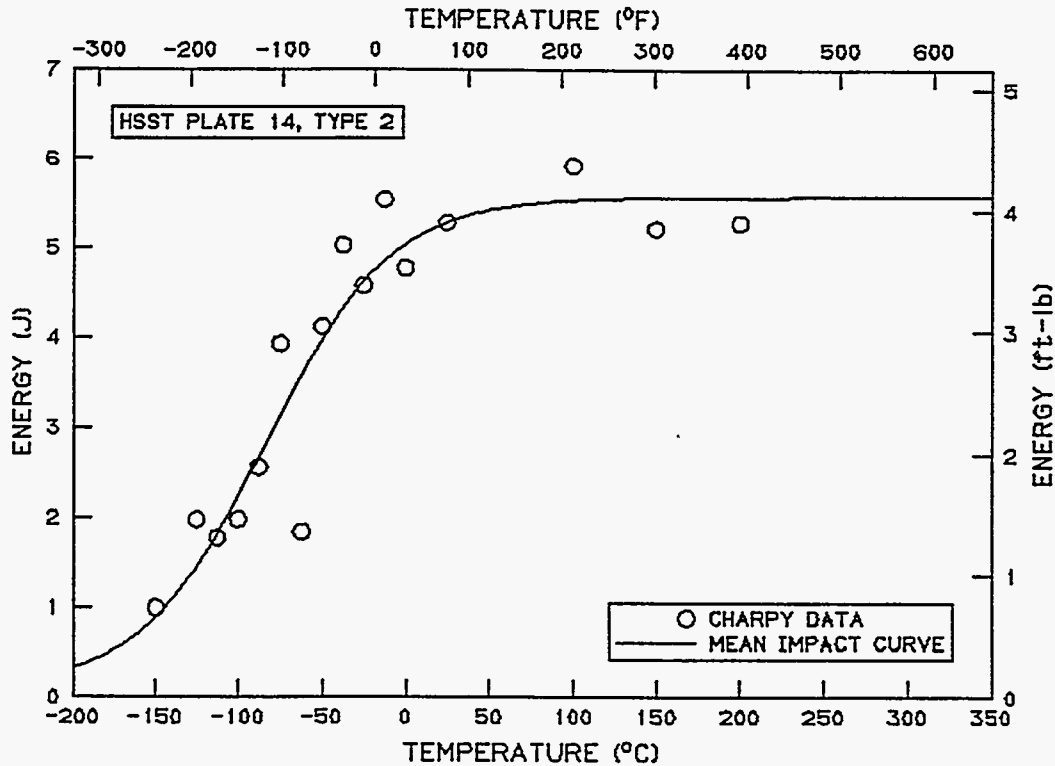

SOURCE: P_14_T2 ANALYSIS SET

Y VARIABLE: EXPANSION

MODEL PARAMETERS

LOWER SHELF EXPANSION [HELD FIXED]: 0.000 (MM), 0.0000 (IN)

MID-TRANSITION TEMPERATURE: -38.7 (DEG C), -37.7 (DEG F)

TRANSITION ZONE WIDTH: 96.9 (C DEG), 174.5 (F DEG)

UPPER SHELF EXPANSION: 0.306 (MM), 0.0121 (IN)

UPPER SHELF EXPANSION: 0.306 (MM), 0.0121 (IN)

NOTE: HSST PLATE 14, TYPE 2

MODEL SET NAME: 2

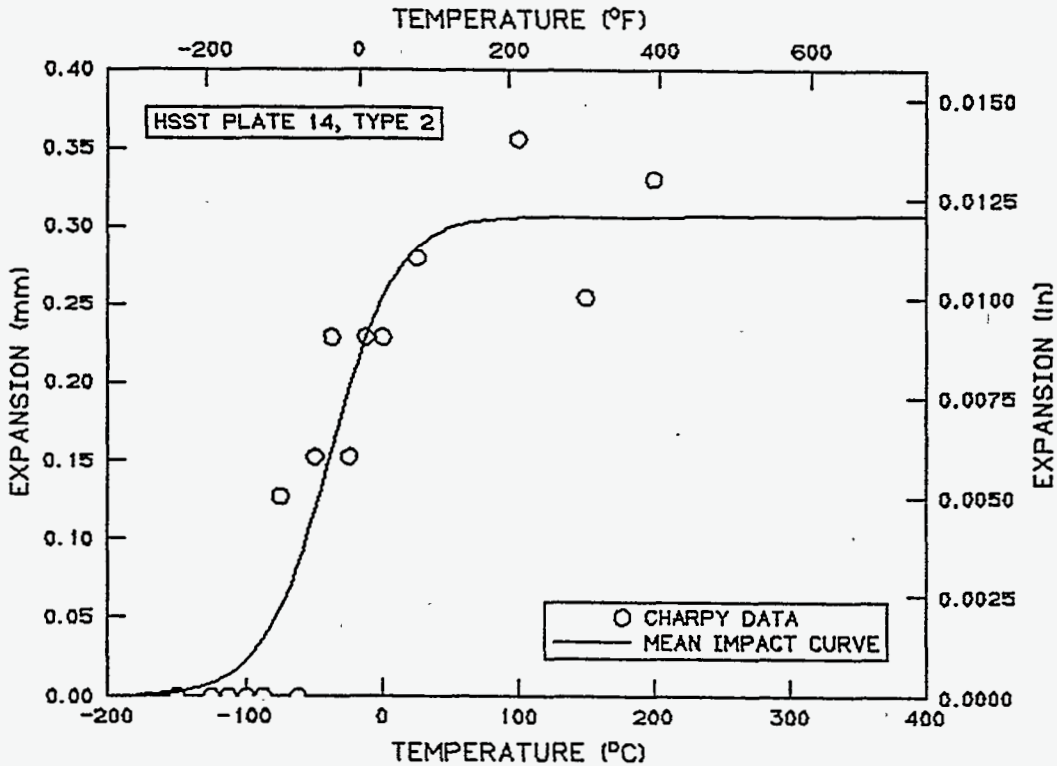

SOURCE: P_14_T2 ANALYSIS SET

Y VARIABLE: SHEAR

MODEL PARAMETERS

LOWER SHELF SHEAR [HELD FIXED]: 0 (PERCENT)

MID-TRANSITION TEMPERATURE:-61.1 (DEG C),-78.0 (DEG F)

TRANSITION ZONE WIDTH: 79.3 (C DEG),142.8 (F DEG)

UPPER SHELF SHEAR [HELD FIXED]: 100 (PERCENT)

UPPER SHELF SHEAR: 100 (PERCENT)

TEMPERATURE [50 (PERCENT),50 (PERCENT) SHEAR]:-61.1 (DEG C),-78.0 (DEG F)

NOTE: HSST PLATE 14, TYPE 2

MODEL SET NAME: 1

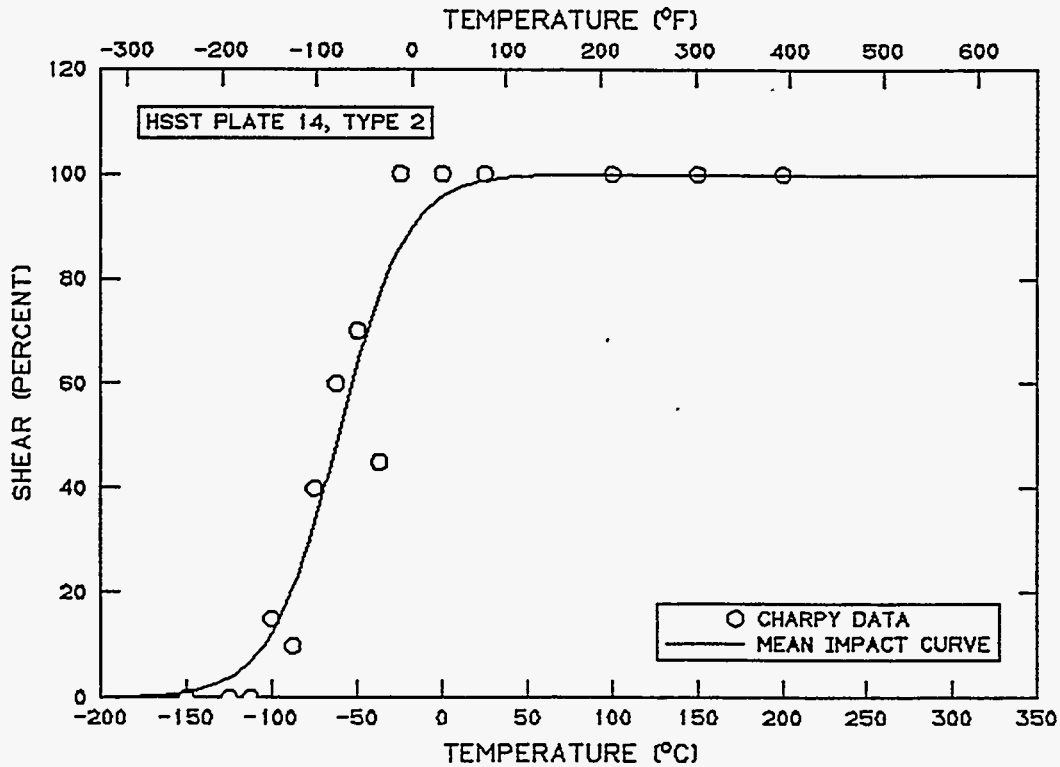

SOURCE: ANALYSIS SET
ANALYSIS SET NAME: P_14_T3

SET NAME: P_14_T3

NOTE: SUB-SIZE CORRELATION PROGRAM, TYPE 3 SPEC., PLATE 14

IDENT	TEMPERATURE		ENERGY		EXPANSION		SHEAR (PERCENT)
	(DEG C)	(DEG F)	(J)	(FT-LB)	(MM)	(IN)	
A436	-150.0	-238.0	3.86	2.85	0.03	0.001	0.0
A440	-150.0	-238.0	3.21	2.37	0.00	0.000	0.0
A435	-125.0	-193.0	3.42	2.52	0.00	0.000	0.0
A437	-112.5	-170.5	5.60	4.13	0.08	0.003	5.0
A434	-100.0	-148.0	5.74	4.23	0.00	0.000	10.0
A438	-75.0	-103.0	6.94	5.12	0.10	0.004	30.0
A433	-50.0	-58.0	8.70	6.42	0.18	0.007	35.0
A439	-12.5	9.5	13.82	10.19	0.33	0.013	86.0
A432	0.0	32.0	14.24	10.50	0.41	0.016	84.0
A429	25.0	77.0	11.93	8.80	0.43	0.017	95.0
A430	100.0	212.0	14.95	11.03	0.53	0.021	100.0
A431	200.0	392.0	11.75	8.67	0.41	0.016	100.0

NUMBER OF SPECIMENS: 12

SOURCE: P_14_T3 ANALYSIS SET

Y VARIABLE: ENERGY

MODEL PARAMETERS

LOWER SHELF ENERGY [HELD FIXED]: 0.1 (J), 0.1 (FT-LB)

MID-TRANSITION TEMPERATURE: -88.3 (DEG C), -126.9 (DEG F)

TRANSITION ZONE WIDTH: 166.1 (C DEG), 299.0 (F DEG)

UPPER SHELF ENERGY: 13.9 (J), 10.2 (FT-LB)

UPPER SHELF ENERGY: 13.9 (J), 10.2 (FT-LB)

NOTE: HSST PLATE 14, TYPE 3

MODEL SET NAME: 4

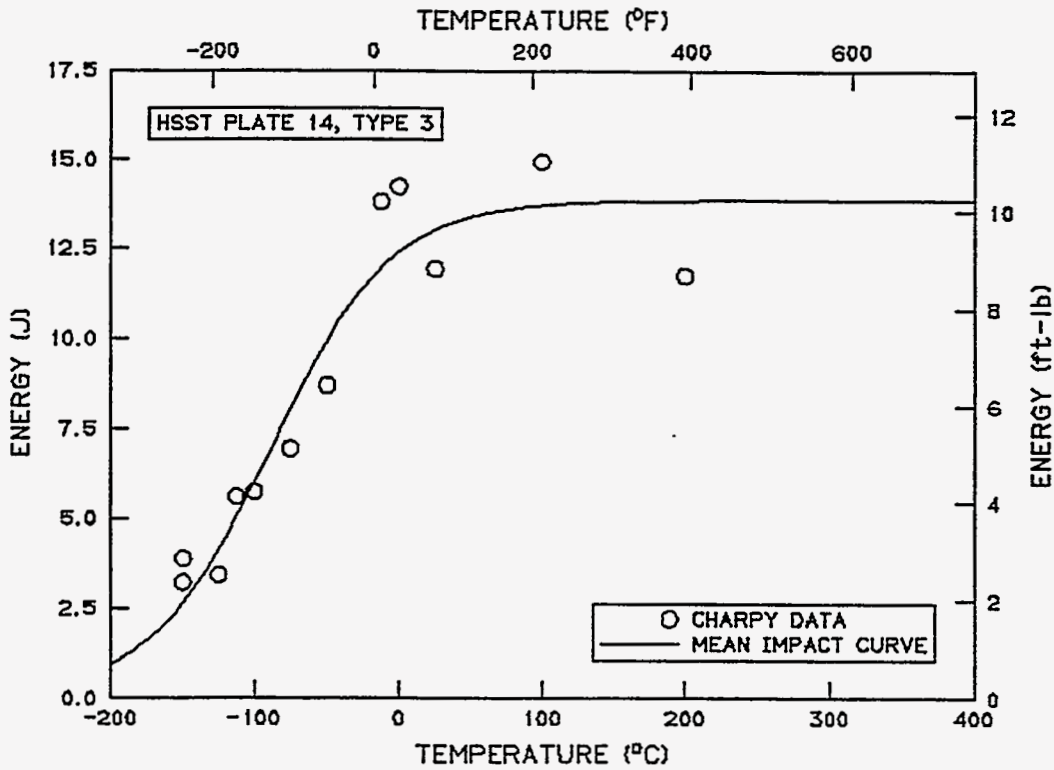

SOURCE: P_14_T3 ANALYSIS SET

Y VARIABLE: EXPANSION

MODEL PARAMETERS

LOWER SHELF EXPANSION [HELD FIXED]: 0.000 (MM), 0.0000 (IN)

MID-TRANSITION TEMPERATURE: -38.4 (DEG C), -37.0 (DEG F)

TRANSITION ZONE WIDTH: 101.1 (C DEG), 182.0 (F DEG)

UPPER SHELF EXPANSION: 0.471 (MM), 0.0185 (IN)

UPPER SHELF EXPANSION: 0.471 (MM), 0.0185 (IN)

NOTE: HSST PLATE 14, TYPE 3

MODEL SET NAME: 5

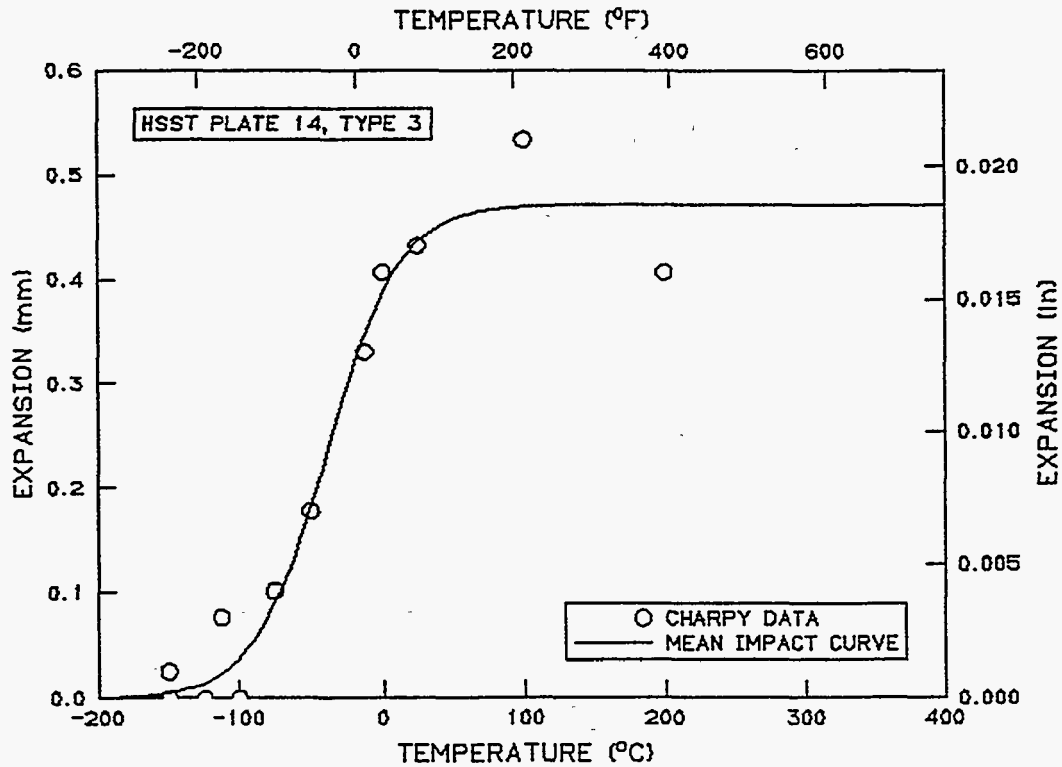

SOURCE: P_14_T3 ANALYSIS SET

Y VARIABLE: SHEAR

MODEL PARAMETERS

LOWER SHELF SHEAR [HELD FIXED]: 0 (PERCENT)

MID-TRANSITION TEMPERATURE:-44.3 (DEG C),-47.7 (DEG F)

TRANSITION ZONE WIDTH: 95.3 (C DEG),171.6 (F DEG)

UPPER SHELF SHEAR [HELD FIXED]: 100 (PERCENT)

UPPER SHELF SHEAR: 100 (PERCENT)

TEMPERATURE [50 (PERCENT),50 (PERCENT) SHEAR]:-44.3 (DEG C),-47.7 (DEG F)

NOTE: HSST PLATE 14, TYPE 3

MODEL SET NAME: 6

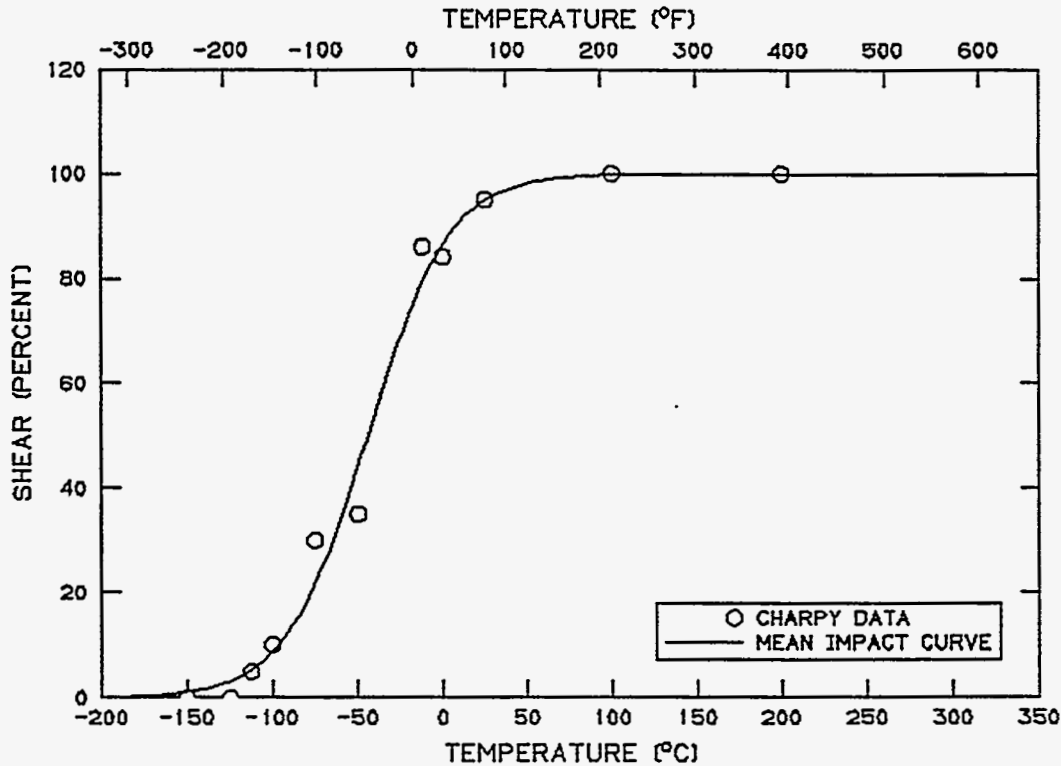

SOURCE: ANALYSIS SET
ANALYSIS SET NAME: P_14_T4

SET NAME: P_14_T4

NOTE: SUB-SIZE CORRELATION PROGRAM, PLATE 14, SPECIMEN TYPE 4

IDENT	TEMPERATURE		ENERGY (J)	EXPANSION			SHEAR (PERCENT)
	(DEG C)	(DEG F)		(FT-LB)	(MM)	(IN)	
A447	-112.5	-170.5	0.53	0.39	0.00	0.000	0.0
A446	-100.0	-148.0	1.25	0.92	0.00	0.000	0.0
A448	-87.5	-125.5	1.25	0.92	0.00	0.000	5.0
A445	-75.0	-103.0	2.24	1.65	0.03	0.001	25.0
A449	-75.0	-103.0	2.62	1.93	0.10	0.004	40.0
A450	-62.5	-80.5	2.82	2.08	0.10	0.004	50.0
A444	-50.0	-58.0	1.45	1.07	0.00	0.000	40.0
A451	-50.0	-58.0	2.56	1.89	0.10	0.004	60.0
A452	-37.5	-35.5	3.85	2.84	0.18	0.007	UNKNOWN
A443	-25.0	-13.0	3.85	2.84	0.20	0.008	90.0
A453	-25.0	-13.0	4.18	3.08	0.18	0.007	UNKNOWN
A442	0.0	32.0	4.18	3.08	0.23	0.009	100.0
A441	25.0	77.0	4.30	3.17	0.25	0.010	100.0
A454	100.0	212.0	4.62	3.41	0.30	0.012	100.0
A455	200.0	392.0	4.04	2.98	0.25	0.010	100.0
A456	200.0	392.0	4.62	3.41	0.38	0.015	100.0

NUMBER OF SPECIMENS: 16

SOURCE: P_14_T4 ANALYSIS SET

Y VARIABLE: ENERGY

MODEL PARAMETERS

LOWER SHELF ENERGY [HELD FIXED]: 0.1 (J), 0.1 (FT-LB)

MID-TRANSITION TEMPERATURE: -67.0 (DEG C), -88.5 (DEG F)

TRANSITION ZONE WIDTH: 109.5 (C DEG), 197.1 (F DEG)

UPPER SHELF ENERGY: 4.5 (J), 3.3 (FT-LB)

UPPER SHELF ENERGY: 4.5 (J), 3.3 (FT-LB)

NOTE: HSST PLATE 14, TYPE 4

MODEL SET NAME: 9

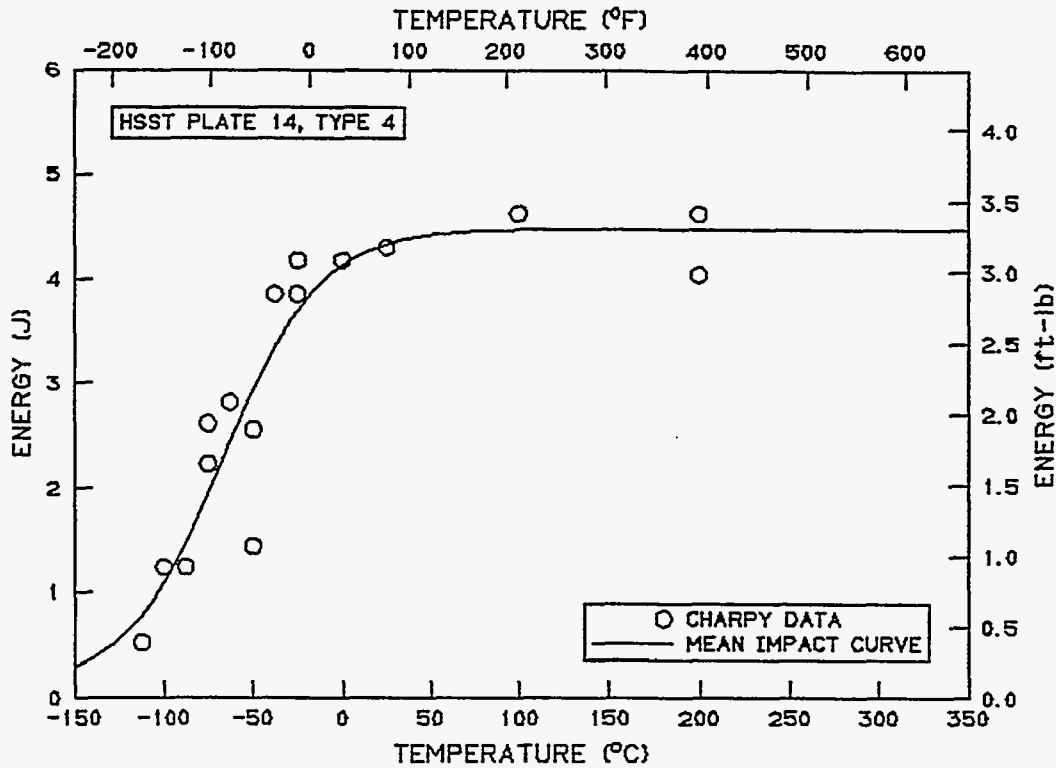

SOURCE: P_14_T4 ANALYSIS SET

Y VARIABLE: EXPANSION

MODEL PARAMETERS

LOWER SHELF EXPANSION [HELD FIXED]: 0.000 (MM), 0.0000 (IN)

MID-TRANSITION TEMPERATURE: -31.9 (DEG C), -25.4 (DEG F)

TRANSITION ZONE WIDTH: 96.1 (C DEG), 173.0 (F DEG)

UPPER SHELF EXPANSION: 0.307 (MM), 0.0121 (IN)

UPPER SHELF EXPANSION: 0.307 (MM), 0.0121 (IN)

NOTE: HSST PLATE 14, TYPE 4

MODEL SET NAME: 8

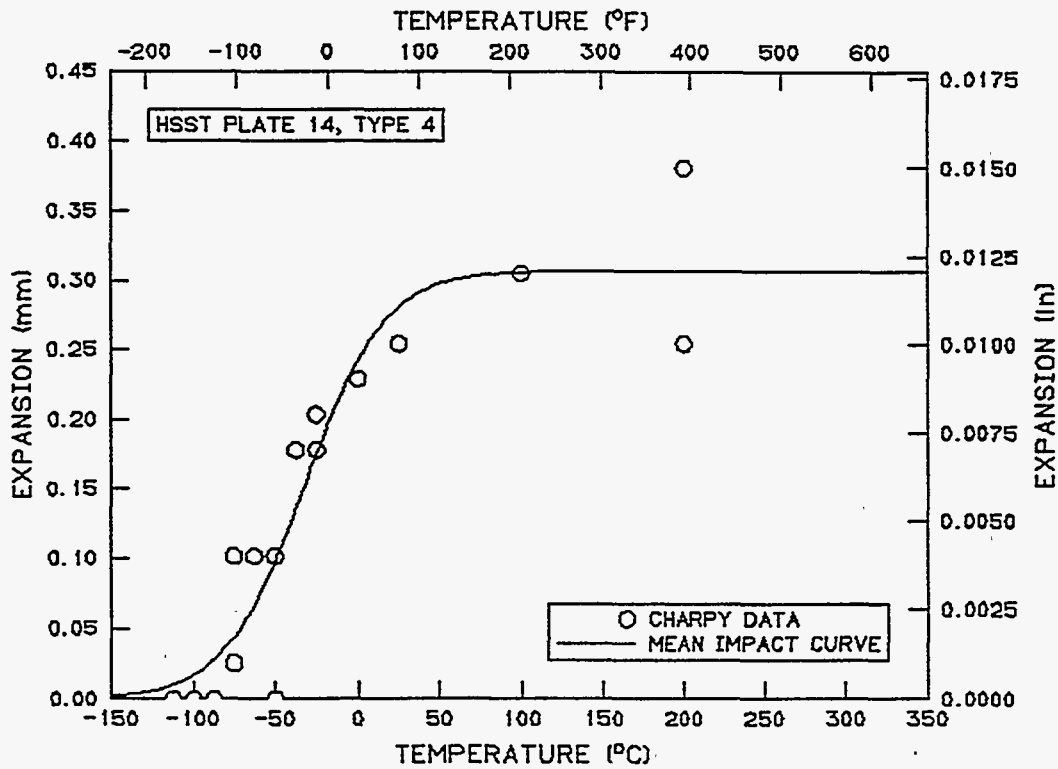

SOURCE: P_14_T4 ANALYSIS SET

Y VARIABLE: SHEAR

MODEL PARAMETERS

LOWER SHELF SHEAR [HELD FIXED]: 0 (PERCENT)

MID-TRANSITION TEMPERATURE: -55.9 (DEG C), -68.6 (DEG F)

TRANSITION ZONE WIDTH: 70.0 (C DEG), 126.0 (F DEG)

UPPER SHELF SHEAR [HELD FIXED]: 100 (PERCENT)

UPPER SHELF SHEAR: 100 (PERCENT)

TEMPERATURE [50 (PERCENT), 50 (PERCENT) SHEAR]: -55.9 (DEG C), -68.6 (DEG F)

NOTE: HSST PLATE 14, TYPE 4

MODEL SET NAME: 7

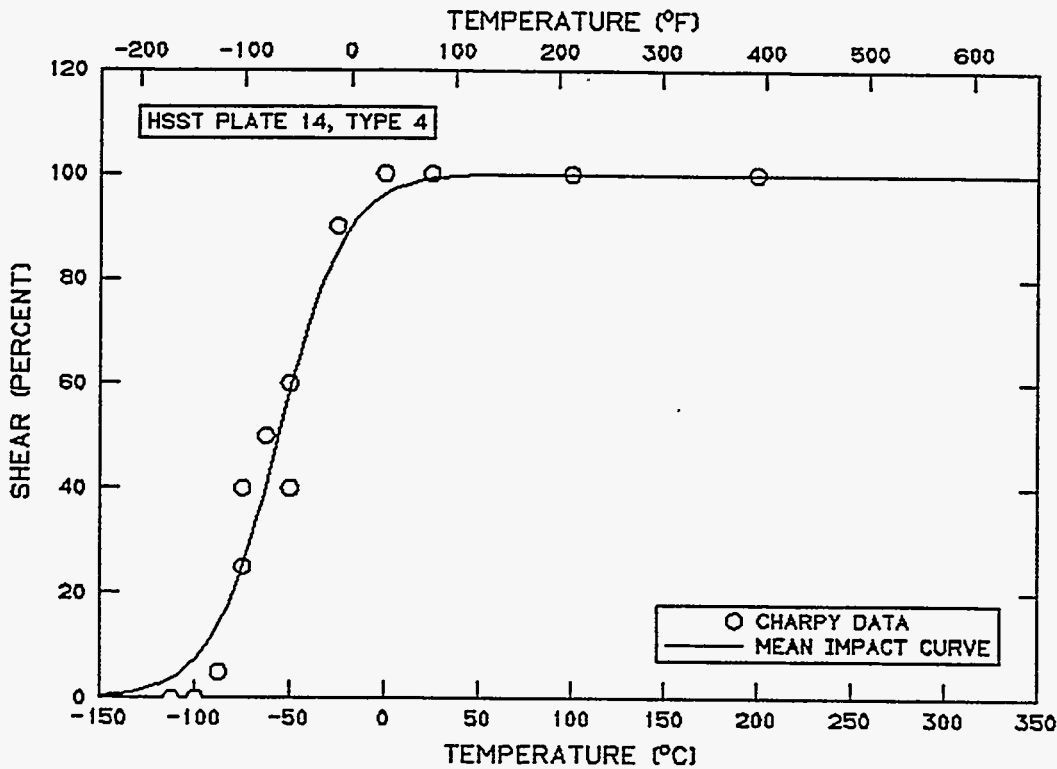

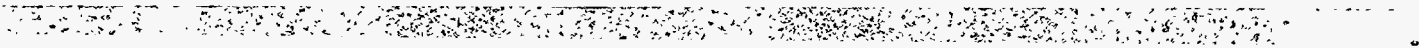

APPENDIX J

15Kh2MFA, FORGING 103672

SOURCE: ANALYSIS SET
ANALYSIS SET NAME: WG3CV

SET NAME: WG3CV
NOTE: RUSSIAN SPECIMENS

IDENT	TEMPERATURE		ENERGY (J)	(FT-LB)	EXPANSION		SHEAR (PERCENT)
	(DEG C)	(DEG F)			(MM)	(IN)	
WG3CV27	-80.0	-112.0	8.81	6.50	0.08	0.003	0.0
WG3CV28	-80.0	-112.0	4.47	3.30	0.05	0.002	0.0
WG3CV24	-40.0	-40.0	59.66	44.00	0.76	0.030	10.0
WG3CV25	-40.0	-40.0	10.71	7.90	0.10	0.004	5.0
WG3CV26	-40.0	-40.0	66.30	48.90	0.91	0.036	10.0
WG3CV19	-20.0	-4.0	76.20	56.20	1.02	0.040	20.0
WG3CV20	-20.0	-4.0	86.91	64.10	1.12	0.044	20.0
WG3CV21	-20.0	-4.0	89.62	66.10	1.22	0.048	20.0
WG3CV31	-20.0	-4.0	93.10	68.67	1.35	0.053	30.0
WG3CV32	-20.0	-4.0	72.10	53.18	0.99	0.039	20.0
WG3CV33	-20.0	-4.0	100.50	74.13	1.42	0.056	35.0
WG3CV34	-20.0	-4.0	110.90	81.80	1.58	0.062	35.0
WG3CV35	-20.0	-4.0	106.70	78.70	1.42	0.056	25.0
WG3CV36	-20.0	-4.0	75.00	55.32	1.04	0.041	20.0
WG3CV37	-20.0	-4.0	68.60	50.60	0.94	0.037	10.0
WG3CV38	-20.0	-4.0	115.20	84.97	1.70	0.067	45.0
WG3CV39	-20.0	-4.0	46.80	34.52	0.71	0.028	5.0
WG3CV40	-20.0	-4.0	117.30	86.52	1.68	0.066	40.0
WG3CV16	0.0	32.0	181.54	133.90	2.08	0.082	100.0
WG3CV17	0.0	32.0	124.74	92.00	1.80	0.071	75.0
WG3CV18	0.0	32.0	129.75	95.70	1.65	0.065	75.0
WG3CV29	20.0	68.0	183.04	135.00	2.08	0.082	100.0
WG3CV30	20.0	68.0	162.56	119.90	2.03	0.080	100.0
WG3CV22	60.0	140.0	190.49	140.50	2.06	0.081	100.0
WG3CV23	60.0	140.0	168.80	124.50	2.06	0.081	100.0
WG3CV41	100.0	212.0	155.00	114.32	1.93	0.076	100.0
WG3CV42	100.0	212.0	178.40	131.58	2.06	0.081	100.0
WG3CV43	100.0	212.0	183.20	135.12	1.93	0.076	100.0
WG3CV44	100.0	212.0	183.20	135.12	1.88	0.074	100.0
WG3CV45	100.0	212.0	181.40	133.80	1.91	0.075	100.0
WG3CV46	100.0	212.0	184.50	136.08	1.98	0.078	100.0
WG3CV47	100.0	212.0	191.60	141.32	2.13	0.084	100.0
WG3CV48	100.0	212.0	182.00	134.24	2.03	0.080	100.0
WG3CV49	100.0	212.0	172.70	127.38	2.18	0.086	100.0
WG3CV50	100.0	212.0	191.80	141.47	1.98	0.078	100.0

NUMBER OF SPECIMENS: 35

SOURCE: WG3CV ANALYSIS SET

Y VARIABLE: ENERGY

MODEL PARAMETERS

LOWER SHELF ENERGY [HELD FIXED]: 2.7 (J), 2.0 (FT-LB)

MID-TRANSITION TEMPERATURE: -19.5 (DEG C), -3.2 (DEG F)

TRANSITION ZONE WIDTH: 61.6 (C DEG), 110.9 (F DEG)

UPPER SHELF ENERGY: 181.3 (J), 133.7 (FT-LB)

UPPER SHELF ENERGY: 181.3 (J), 133.7 (FT-LB)

TEMPERATURE [41 (J), 30.2 (FT-LB) ENERGY]: -39.5 (DEG C), -39.2 (DEG F)

TEMPERATURE [68 (J), 50.2 (FT-LB) ENERGY]: -28.0 (DEG C), -18.5 (DEG F)

NOTE: NONE

MODEL SET NAME: 3

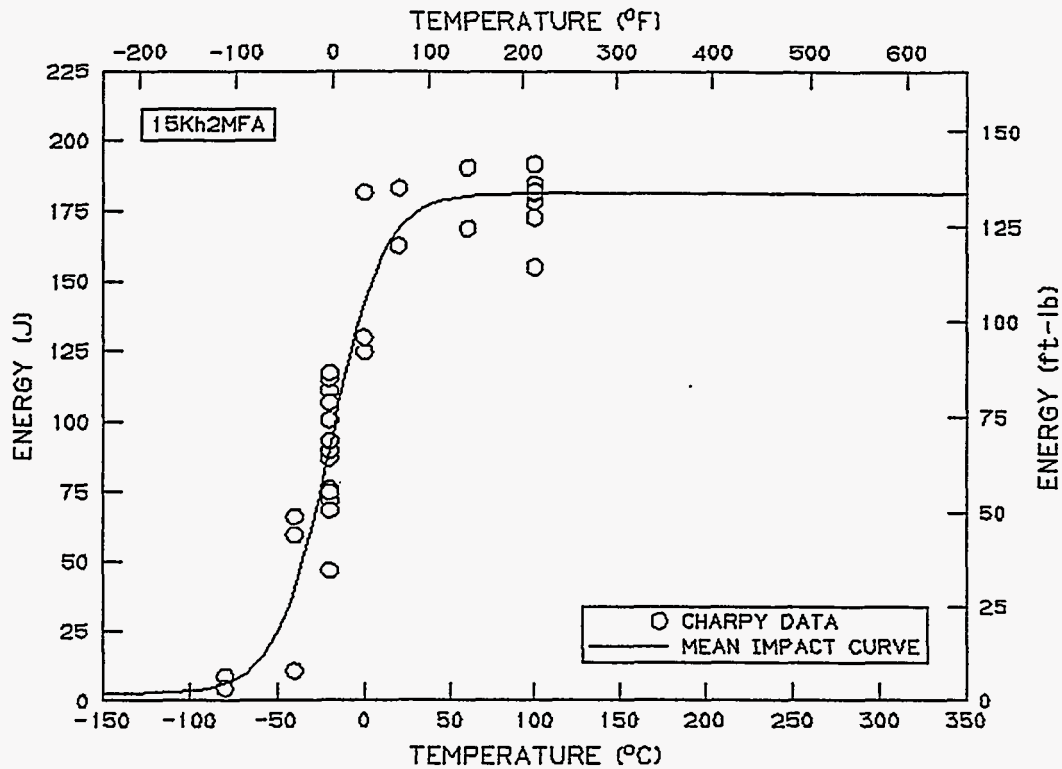

SOURCE: WG3CV ANALYSIS SET

Y VARIABLE: EXPANSION

MODEL PARAMETERS

LOWER SHELF EXPANSION [HELD FIXED]: 0.061 (MM), 0.0024 (IN)

MID-TRANSITION TEMPERATURE: -25.7 (DEG C), -14.2 (DEG F)

TRANSITION ZONE WIDTH: 51.1 (C DEG), 92.0 (F DEG)

UPPER SHELF EXPANSION: 2.029 (MM), 0.0799 (IN)

UPPER SHELF EXPANSION: 2.029 (MM), 0.0799 (IN)

NOTE: NONE

MODEL SET NAME: 2

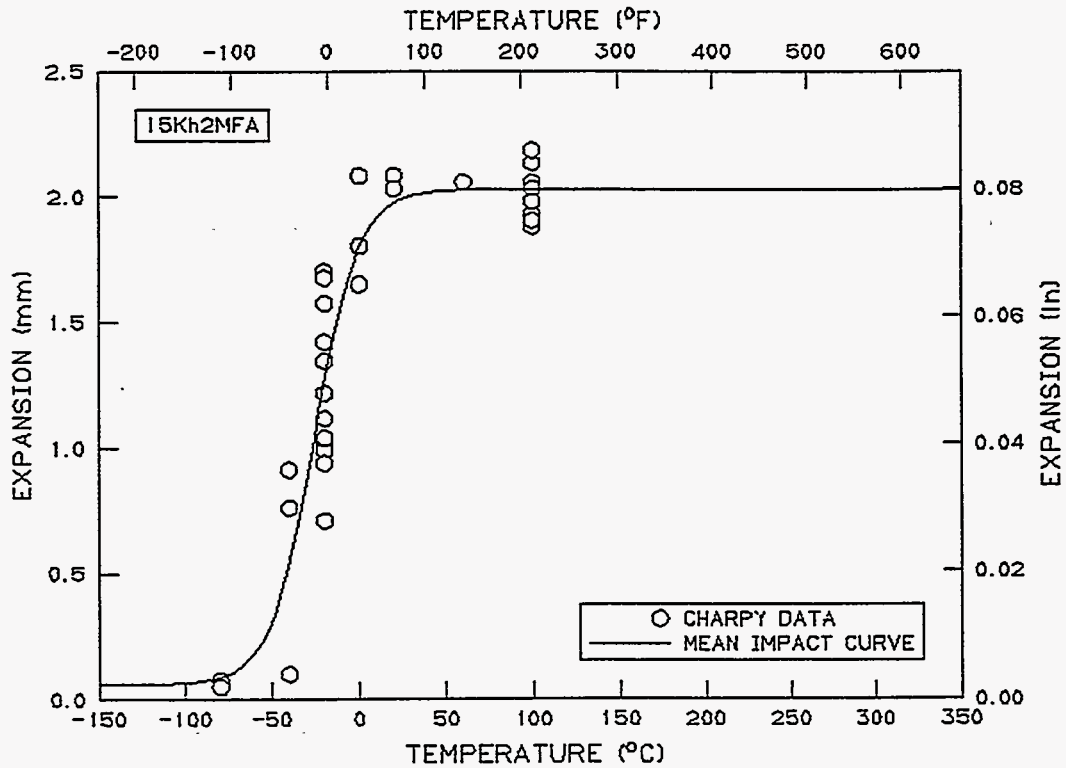

SOURCE: WG3CV ANALYSIS SET

Y VARIABLE: SHEAR

MODEL PARAMETERS

LOWER SHELF SHEAR [HELD FIXED]: 0 (PERCENT)

MID-TRANSITION TEMPERATURE: -11.8 (DEG C), 10.8 (DEG F)

TRANSITION ZONE WIDTH: 30.3 (C DEG), 54.6 (F DEG)

UPPER SHELF SHEAR [HELD FIXED]: 100 (PERCENT)

UPPER SHELF SHEAR: 100 (PERCENT)

NOTE: NONE

MODEL SET NAME: 1

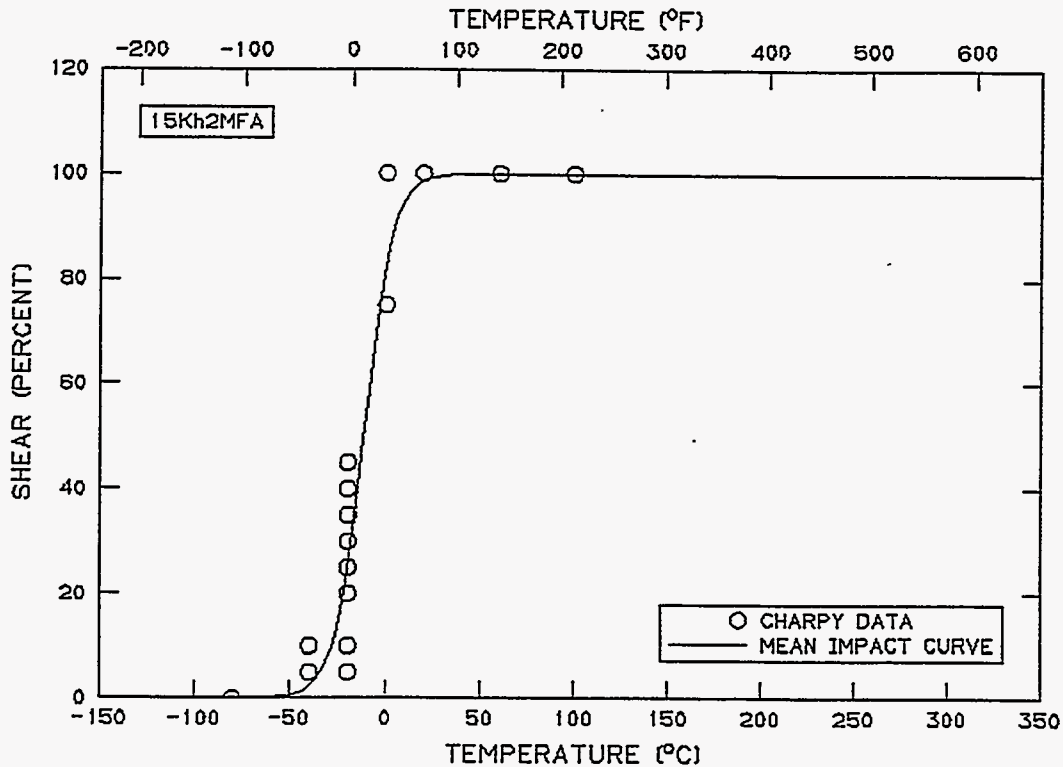

SOURCE: ANALYSIS SET
ANALYSIS SET NAME: VVER440_.T1

SET NAME: VVER440_.T1
NOTE: VVER-440, TYPE 1 SPECIMENS

IDENT	TEMPERATURE		ENERGY (J)	(FT-LB)	EXPANSION		SHEAR (PERCENT)
	(DEG C)	(DEG F)			(MM)	(IN)	
3G38	-100.0	-148.0	0.54	0.40	0.00	0.000	0.0
3G37	-87.5	-125.5	4.47	3.30	0.08	0.003	5.0
3G36	-75.0	-103.0	9.49	7.00	0.41	0.016	10.0
3G35	-62.5	-80.5	9.63	7.10	0.41	0.016	15.0
3G34	-50.0	-58.0	17.22	12.70	0.84	0.033	50.0
3G51	-37.5	-35.5	15.32	11.30	0.71	0.028	60.0
3G52	-25.0	-13.0	15.19	11.20	0.71	0.028	65.0
3G53	-12.5	9.5	29.69	21.90	1.02	0.040	100.0
3G54	0.0	32.0	27.25	20.10	0.97	0.038	100.0
3G55	12.5	54.5	26.17	19.30	0.91	0.036	100.0
3G39	25.0	77.0	26.85	19.80	0.91	0.036	100.0
3G40	100.0	212.0	21.96	16.20	0.81	0.032	100.0
3G57	100.0	212.0	37.15	27.40	0.66	0.026	100.0
3G56	150.0	302.0	30.91	22.80	0.86	0.034	100.0
3G58	200.0	392.0	26.71	19.70	0.71	0.028	100.0

NUMBER OF SPECIMENS: 15

SOURCE: VVER440_.T1 ANALYSIS SET

Y VARIABLE: ENERGY

MODEL PARAMETERS

LOWER SHELF ENERGY [HELD FIXED]: 0.1 (J), 0.1 (FT-LB)

MID-TRANSITION TEMPERATURE: -47.7 (DEG C), -53.9 (DEG F)

TRANSITION ZONE WIDTH: 95.1 (C DEG), 171.2 (F DEG)

UPPER SHELF ENERGY: 29.2 (J), 21.6 (FT-LB)

UPPER SHELF ENERGY: 29.2 (J), 21.6 (FT-LB)

NOTE: 15Kh2MFA, TYPE 1

MODEL SET NAME: 0

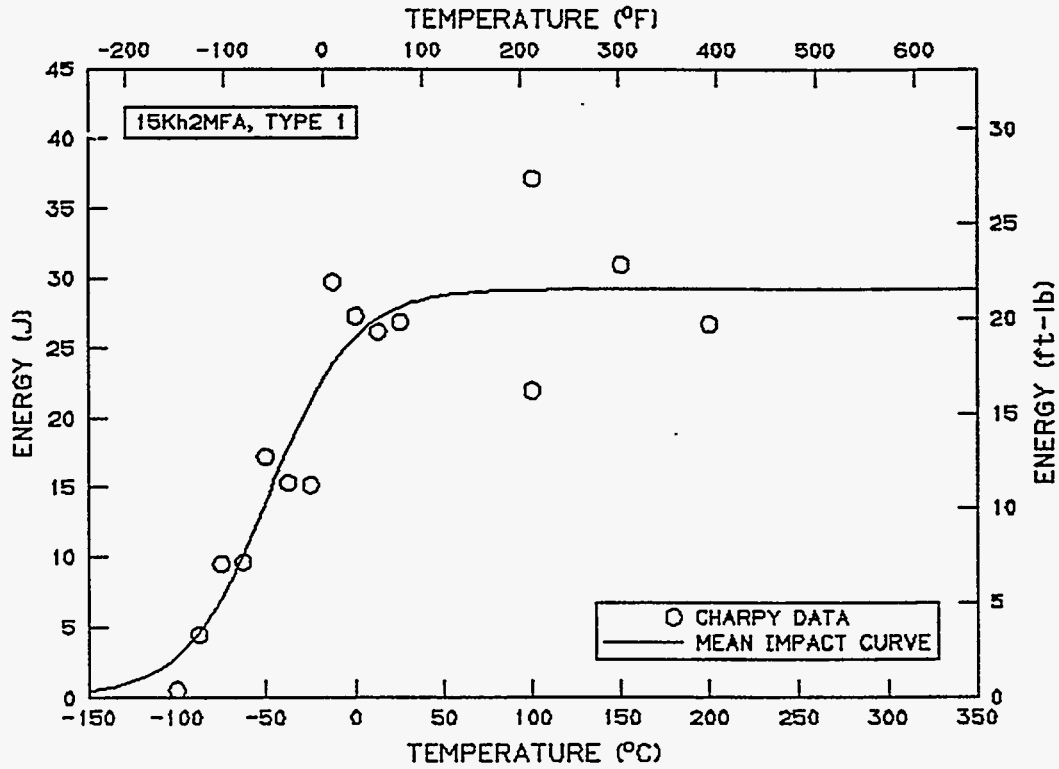

SOURCE: VVER440_.T1 ANALYSIS SET

Y VARIABLE: EXPANSION

MODEL PARAMETERS

LOWER SHELF EXPANSION [HELD FIXED]: 0.000 (MM),0.0000 (IN)

MID-TRANSITION TEMPERATURE:-68.3 (DEG C),-91.0 (DEG F)

TRANSITION ZONE WIDTH: 43.3 (C DEG),78.0 (F DEG)

UPPER SHELF EXPANSION: 0.841 (MM),0.0331 (IN)

UPPER SHELF EXPANSION: 0.841 (MM),0.0331 (IN)

NOTE: 15Kh2MFA, TYPE 1

MODEL SET NAME: 1

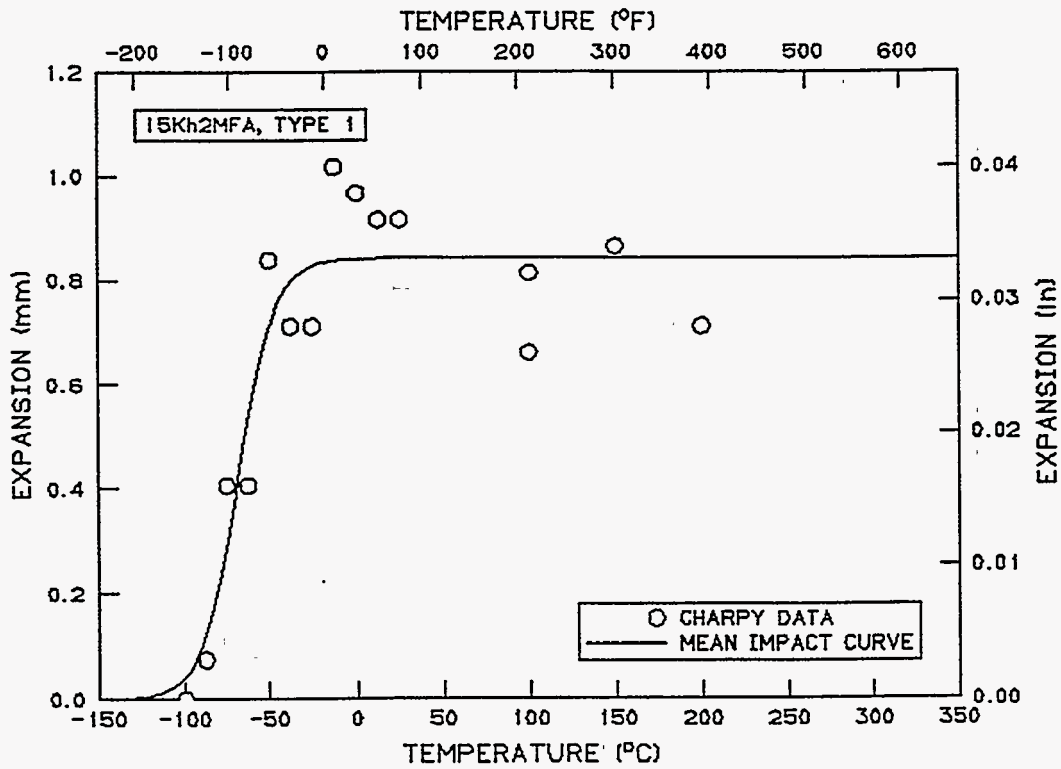

SOURCE: VVER440_.T1 ANALYSIS SET

Y VARIABLE: SHEAR

MODEL PARAMETERS

LOWER SHELF SHEAR [HELD FIXED]: 0 (PERCENT)

MID-TRANSITION TEMPERATURE:-43.9 (DEG C),-47.0 (DEG F)

TRANSITION ZONE WIDTH: 57.2 (C DEG),102.9 (F DEG)

UPPER SHELF SHEAR [HELD FIXED]: 100 (PERCENT)

UPPER SHELF SHEAR: 100 (PERCENT)

TEMPERATURE [50 (PERCENT),50 (PERCENT) SHEAR]:-43.9 (DEG C),-47.0 (DEG F)

NOTE: 15Kh2MFA, TYPE 1

MODEL SET NAME: 2

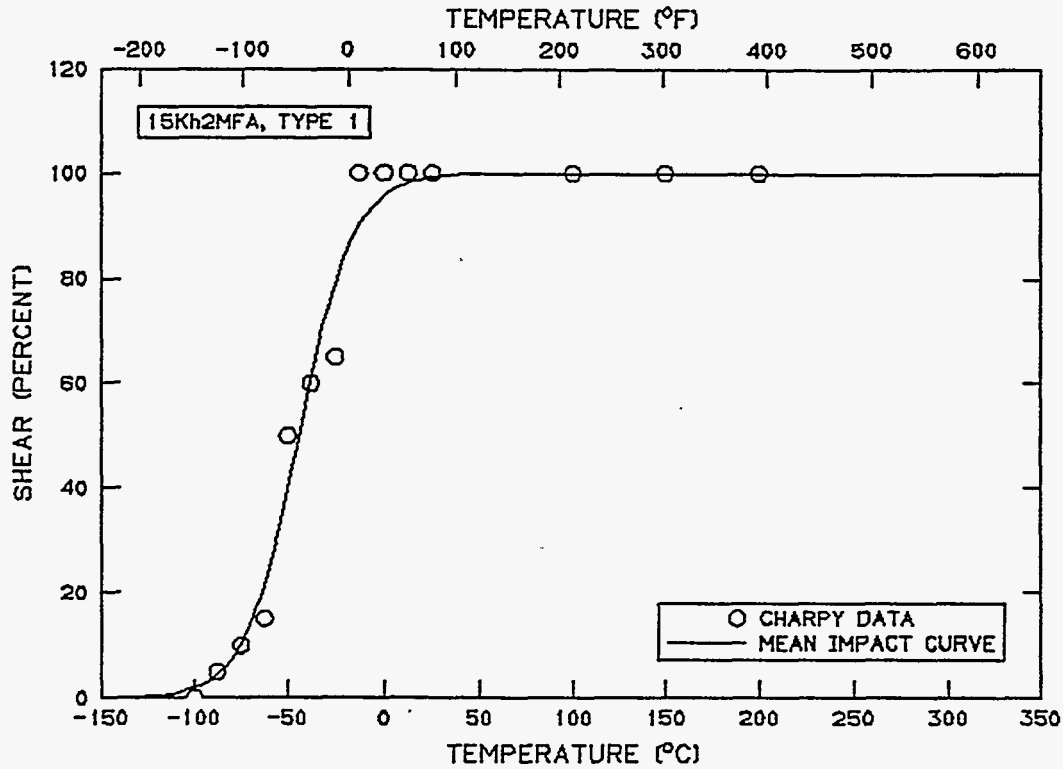

SOURCE: ANALYSIS SET
ANALYSIS SET NAME: VVER440_.T2

SET NAME: VVER440_.T2
NOTE: VVER-440, SPEC. TYPE 2

IDENT	TEMPERATURE		ENERGY (J)	EXPANSION		SHEAR (PERCENT)	
	(DEG C)	(DEG F)		(FT-LB)	(MM)		(IN)
3G23	-137.5	-215.5	0.00	0.00	0.00	0.000	0.0
3G24	-125.0	-193.0	0.14	0.10	0.00	0.000	0.0
3G67	-125.0	-193.0	0.00	0.00	0.00	0.000	0.0
3G22	-112.5	-170.5	3.66	2.70	0.28	0.011	10.0
3G32	-112.5	-170.5	2.71	2.00	0.08	0.003	5.0
3G72	-112.5	-170.5	0.00	0.00	0.00	0.000	0.0
3G25	-100.0	-148.0	5.02	3.70	0.41	0.016	20.0
3G68	-100.0	-148.0	4.47	3.30	0.33	0.013	10.0
3G21	-87.5	-125.5	5.69	4.20	0.41	0.016	20.0
3G26	-75.0	-103.0	4.75	3.50	0.38	0.015	20.0
3G31	-75.0	-103.0	5.69	4.20	0.46	0.018	30.0
3G27	-62.5	-80.5	5.56	4.10	0.46	0.018	35.0
3G69	-62.5	-80.5	8.54	6.30	0.58	0.023	100.0
3G28	-50.0	-58.0	8.54	6.30	0.61	0.024	100.0
3G29	-37.5	-35.5	8.41	6.20	0.58	0.023	100.0
3G30	-25.0	-13.0	9.08	6.70	0.64	0.025	100.0
3G70	50.0	122.0	8.54	6.30	0.61	0.024	100.0
3G71	100.0	212.0	7.73	5.70	0.66	0.026	100.0

NUMBER OF SPECIMENS: 18

SOURCE: VVER440_.T2 ANALYSIS SET

Y VARIABLE: ENERGY

MODEL PARAMETERS

LOWER SHELF ENERGY [HELD FIXED]: 0.1 (J), 0.1 (FT-LB)

MID-TRANSITION TEMPERATURE: -94.4 (DEG C), -137.9 (DEG F)

TRANSITION ZONE WIDTH: 65.0 (C DEG), 116.9 (F DEG)

UPPER SHELF ENERGY: 8.4 (J), 6.2 (FT-LB)

UPPER SHELF ENERGY: 8.4 (J), 6.2 (FT-LB)

NOTE: 15Kh2MFA, TYPE 2

MODEL SET NAME: 5

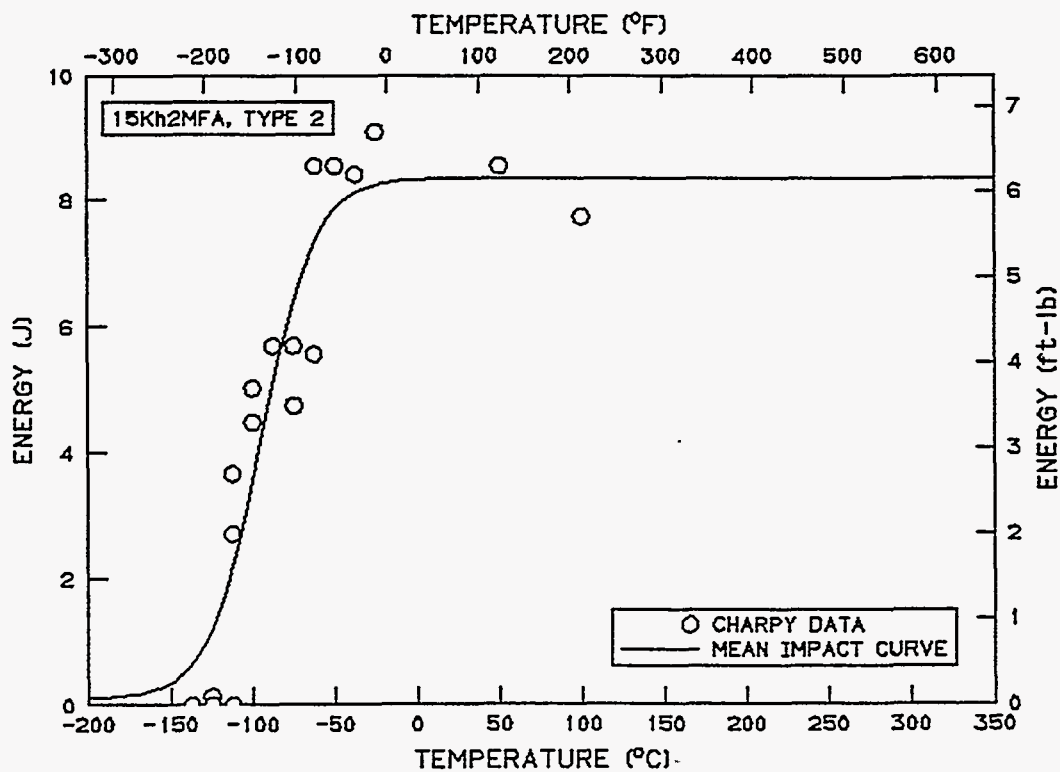

SOURCE: VVER440_.T2 ANALYSIS SET

Y VARIABLE: EXPANSION

MODEL PARAMETERS

LOWER SHELF EXPANSION [HELD FIXED]: 0.000 (MM), 0.0000 (IN)

MID-TRANSITION TEMPERATURE: -95.7 (DEG C), -140.3 (DEG F)

TRANSITION ZONE WIDTH: 58.3 (C DEG), 105.0 (F DEG)

UPPER SHELF EXPANSION: 0.607 (MM), 0.0239 (IN)

UPPER SHELF EXPANSION: 0.607 (MM), 0.0239 (IN)

NOTE: 15Kh2MFA, TYPE 2

MODEL SET NAME: 4

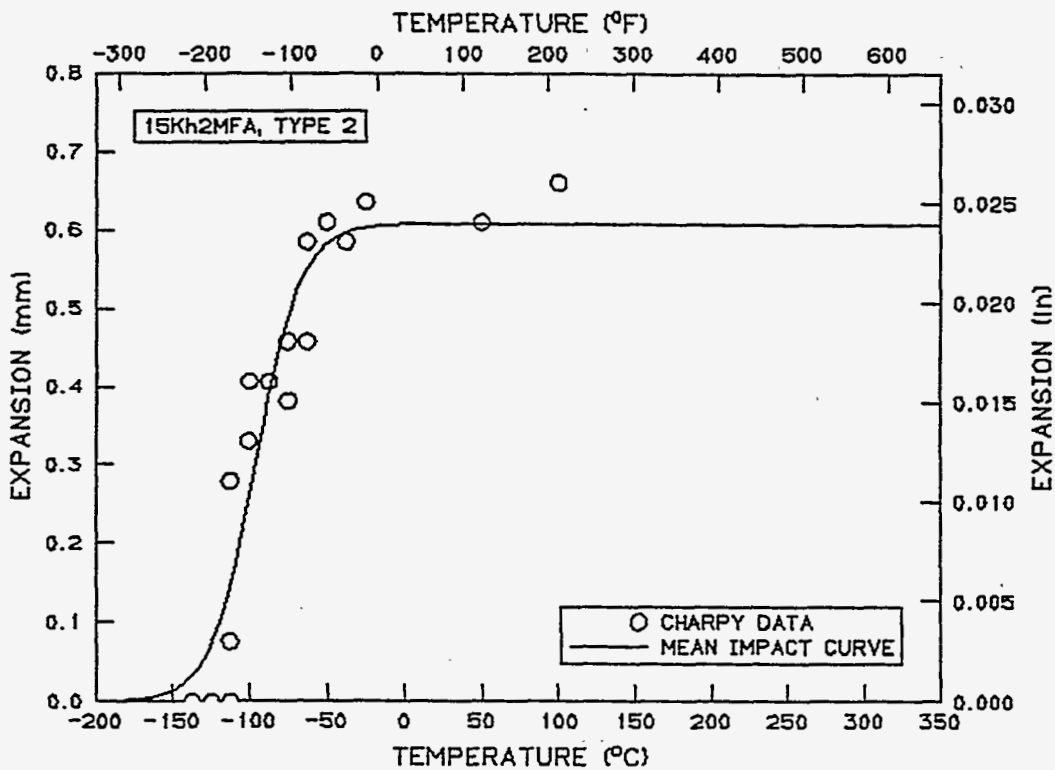

SOURCE: VVER440_.T2 ANALYSIS SET

Y VARIABLE: SHEAR

MODEL PARAMETERS

LOWER SHELF SHEAR [HELD FIXED]: 0 (PERCENT)

MID-TRANSITION TEMPERATURE:-68.4 (DEG C),-91.2 (DEG F)

TRANSITION ZONE WIDTH: 33.6 (C DEG),60.5 (F DEG)

UPPER SHELF SHEAR [HELD FIXED]: 100 (PERCENT)

UPPER SHELF SHEAR: 100 (PERCENT)

TEMPERATURE [50 (PERCENT),50 (PERCENT) SHEAR]:-68.4 (DEG C),-91.2 (DEG F)

NOTE: 15Kh2MFA, TYPE 2

MODEL SET NAME: 3

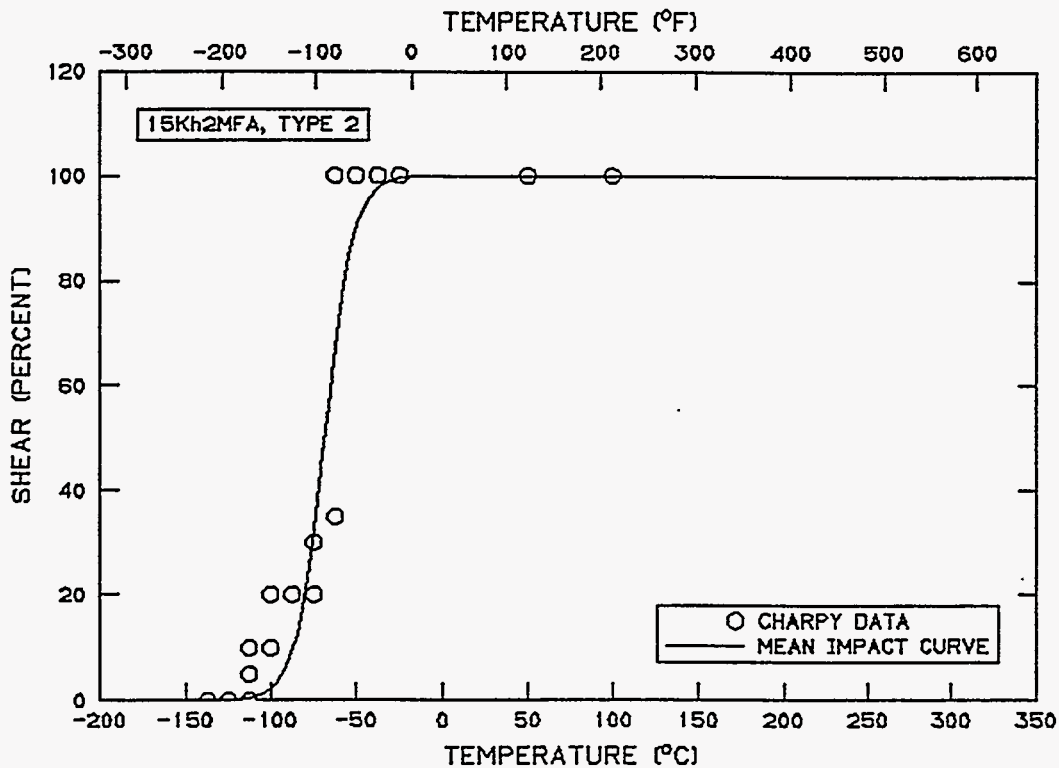

SOURCE: ANALYSIS SET
ANALYSIS SET NAME: VVER440_.T3

SET NAME: VVER440_.T3
NOTE: VVER-440, SPECIMEN TYPE 3

IDENT	TEMPERATURE (DEG C) (DEG F)		ENERGY (J)	(FT-LB)	EXPANSION (MM) (IN)		SHEAR (PERCENT)
3G16	-112.5	-170.5	0.41	0.30	0.15	0.006	0.0
3G14	-100.0	-148.0	0.81	0.60	0.13	0.005	0.0
6G46	-100.0	-148.0	0.54	0.40	0.15	0.006	0.0
3G13	-87.5	-125.5	8.68	6.40	0.33	0.013	0.0
6G47	-87.5	-125.5	2.71	2.00	0.00	0.000	0.0
3G15	-75.0	-103.0	13.42	9.90	0.66	0.026	20.0
3G17	-62.5	-80.5	12.07	8.90	0.61	0.024	15.0
3G18	-50.0	-58.0	14.10	10.40	0.66	0.026	45.0
3G19	-37.5	-35.5	15.73	11.60	0.79	0.031	70.0
3G20	-25.0	-13.0	13.29	9.80	0.61	0.024	65.0
6G45	-25.0	-13.0	25.22	18.60	0.89	0.035	100.0
6G44	-12.5	9.5	24.68	18.20	0.86	0.034	100.0
6G43	0.0	32.0	25.22	18.60	0.91	0.036	100.0
6G41	50.0	122.0	22.64	16.70	0.91	0.036	100.0
6G42	100.0	212.0	25.22	18.60	0.89	0.035	100.0

NUMBER OF SPECIMENS: 15

SOURCE: VVER440_.T3 ANALYSIS SET

Y VARIABLE: ENERGY

MODEL PARAMETERS

LOWER SHELF ENERGY [HELD FIXED]: 0.1 (J), 0.1 (FT-LB)

MID-TRANSITION TEMPERATURE: -59.7 (DEG C), -75.4 (DEG F)

TRANSITION ZONE WIDTH: 85.4 (C DEG), 153.7 (F DEG)

UPPER SHELF ENERGY: 24.6 (J), 18.1 (FT-LB)

UPPER SHELF ENERGY: 24.6 (J), 18.1 (FT-LB)

NOTE: 15Kh2MFA, TYPE 3

MODEL SET NAME: 6

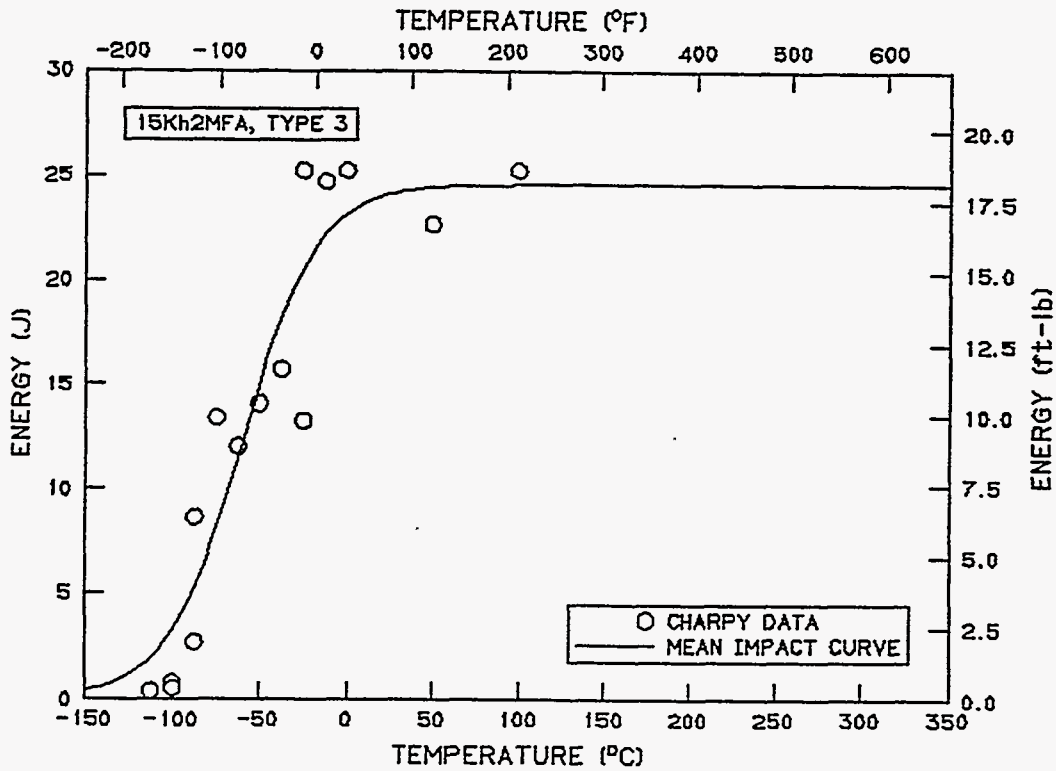

SOURCE: VVER440_.T3 ANALYSIS SET

Y VARIABLE: EXPANSION

MODEL PARAMETERS

LOWER SHELF EXPANSION [HELD FIXED]: 0.000 (MM), 0.0000 (IN)

MID-TRANSITION TEMPERATURE: -75.5 (DEG C), -103.9 (DEG F)

TRANSITION ZONE WIDTH: 62.9 (C DEG), 113.3 (F DEG)

UPPER SHELF EXPANSION: 0.863 (MM), 0.0340 (IN)

UPPER SHELF EXPANSION: 0.863 (MM), 0.0340 (IN)

NOTE: 15Kh2MFA, TYPE 3

MODEL SET NAME: 7

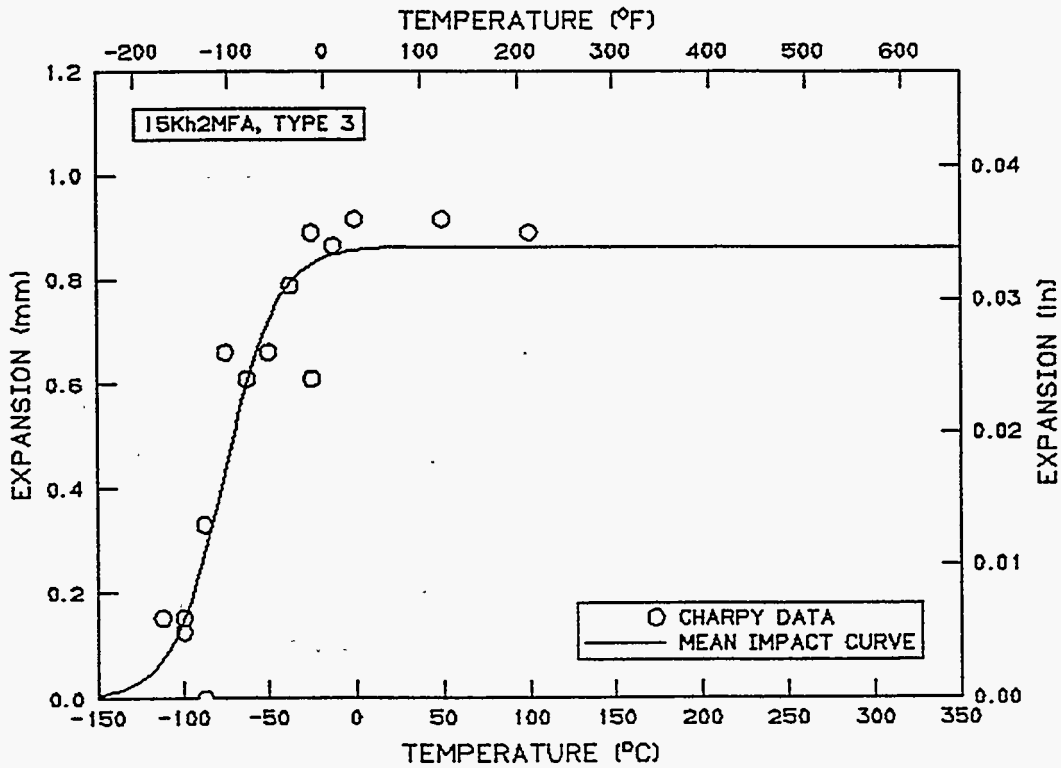

SOURCE: VVER440_.T3 ANALYSIS SET

Y VARIABLE: SHEAR

MODEL PARAMETERS

LOWER SHELF SHEAR [HELD FIXED]: 0 (PERCENT)

MID-TRANSITION TEMPERATURE:-46.7 (DEG C),-52.0 (DEG F)

TRANSITION ZONE WIDTH: 48.6 (C DEG),87.4 (F DEG)

UPPER SHELF SHEAR [HELD FIXED]: 100 (PERCENT)

UPPER SHELF SHEAR: 100 (PERCENT)

TEMPERATURE [50 (PERCENT),50 (PERCENT) SHEAR]:-46.7 (DEG C),-52.0 (DEG F)

NOTE: 15Kh2MFA, TYPE 3

MODEL SET NAME: 8

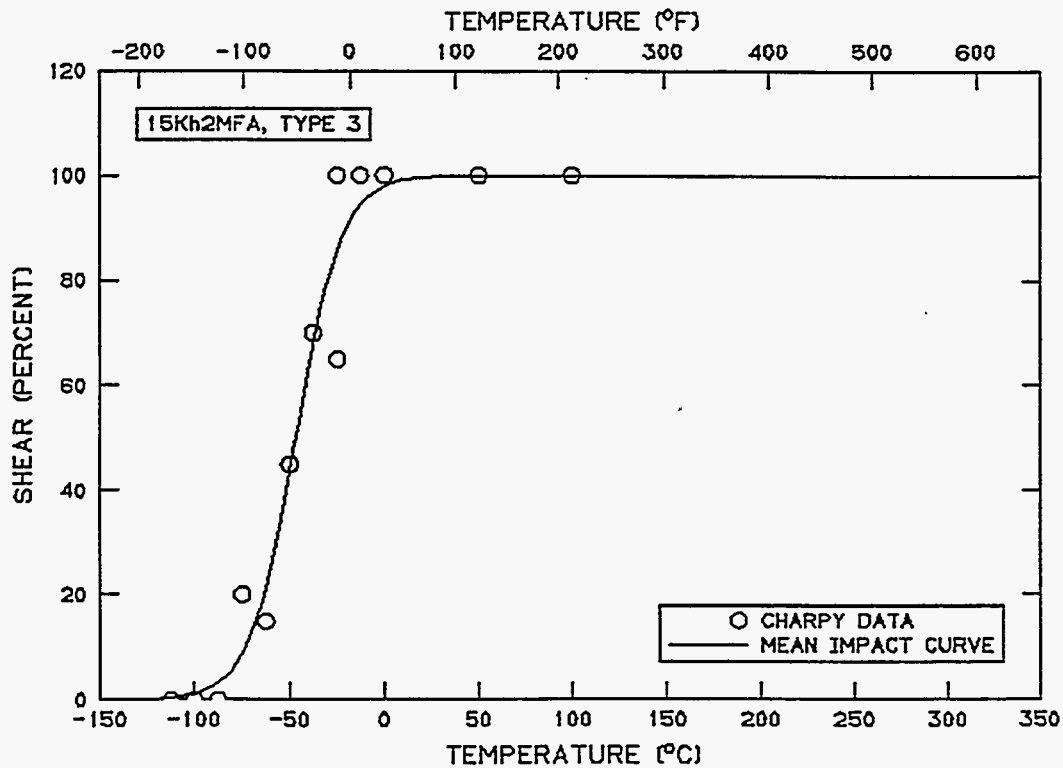

SOURCE: ANALYSIS SET
ANALYSIS SET NAME: VVER440_.T4

SET NAME: VVER440_.T4
NOTE: VVER-440, TYPE 4

IDENT	TEMPERATURE		ENERGY (J)	EXPANSION			SHEAR (PERCENT)
	(DEG C)	(DEG F)		(FT-LB)	(MM)	(IN)	
3G07	-100.0	-148.0	0.20	0.15	0.00	0.000	0.0
3G08	-87.5	-125.5	0.20	0.15	0.00	0.000	0.0
3G12	-87.5	-125.5	0.72	0.53	0.00	0.000	0.0
6G63	-87.5	-125.5	0.34	0.25	0.00	0.000	0.0
3G09	-75.0	-103.0	3.46	2.55	0.23	0.009	10.0
6G61	-75.0	-103.0	3.59	2.65	0.25	0.010	10.0
6G64	-75.0	-103.0	0.62	0.46	0.00	0.000	0.0
3G10	-62.5	-80.5	5.19	3.83	0.38	0.015	40.0
6G62	-62.5	-80.5	5.00	3.69	0.41	0.016	45.0
6G65	-62.5	-80.5	5.23	3.86	0.28	0.011	20.0
3G11	-50.0	-58.0	7.78	5.74	0.61	0.024	100.0
6G66	-50.0	-58.0	3.82	2.82	0.25	0.010	10.0
3G06	-37.5	-35.5	8.16	6.02	0.56	0.022	100.0
3G05	-25.0	-13.0	7.54	5.56	0.58	0.023	100.0
3G04	-12.5	9.5	7.54	5.56	0.61	0.024	100.0
3G03	0.0	32.0	7.97	5.88	0.66	0.026	100.0
3G02	12.5	54.5	8.04	5.93	0.61	0.024	100.0
3G01	25.0	77.0	7.54	5.56	0.53	0.021	100.0

NUMBER OF SPECIMENS: 18

SOURCE: VVER440_.T4 ANALYSIS SET

Y VARIABLE: ENERGY

MODEL PARAMETERS

LOWER SHELF ENERGY [HELD FIXED]: 0.1 (J), 0.1 (FT-LB)

MID-TRANSITION TEMPERATURE: -67.3 (DEG C), -89.1 (DEG F)

TRANSITION ZONE WIDTH: 37.0 (C DEG), 66.5 (F DEG)

UPPER SHELF ENERGY: 7.7 (J), 5.7 (FT-LB)

UPPER SHELF ENERGY: 7.7 (J), 5.7 (FT-LB)

NOTE: 15Kh2MFA, TYPE 4

MODEL SET NAME: 1

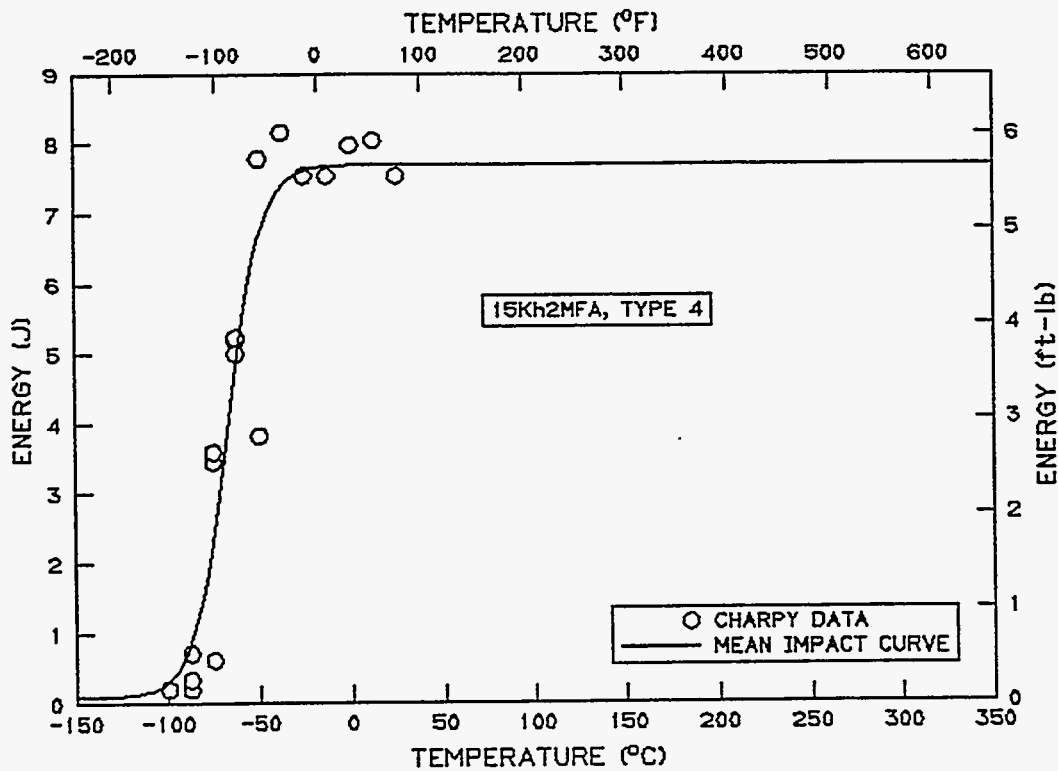

SOURCE: VVER440_T4 ANALYSIS SET

Y VARIABLE: EXPANSION

MODEL PARAMETERS

LOWER SHELF EXPANSION [HELD FIXED]: 0.000 (MM), 0.0000 (IN)

MID-TRANSITION TEMPERATURE: -64.6 (DEG C), -84.3 (DEG F)

TRANSITION ZONE WIDTH: 37.9 (C DEG), 68.2 (F DEG)

UPPER SHELF EXPANSION: 0.592 (MM), 0.0233 (IN)

UPPER SHELF EXPANSION: 0.592 (MM), 0.0233 (IN)

NOTE: 15Kh2MFA, TYPE 4

MODEL SET NAME: 0

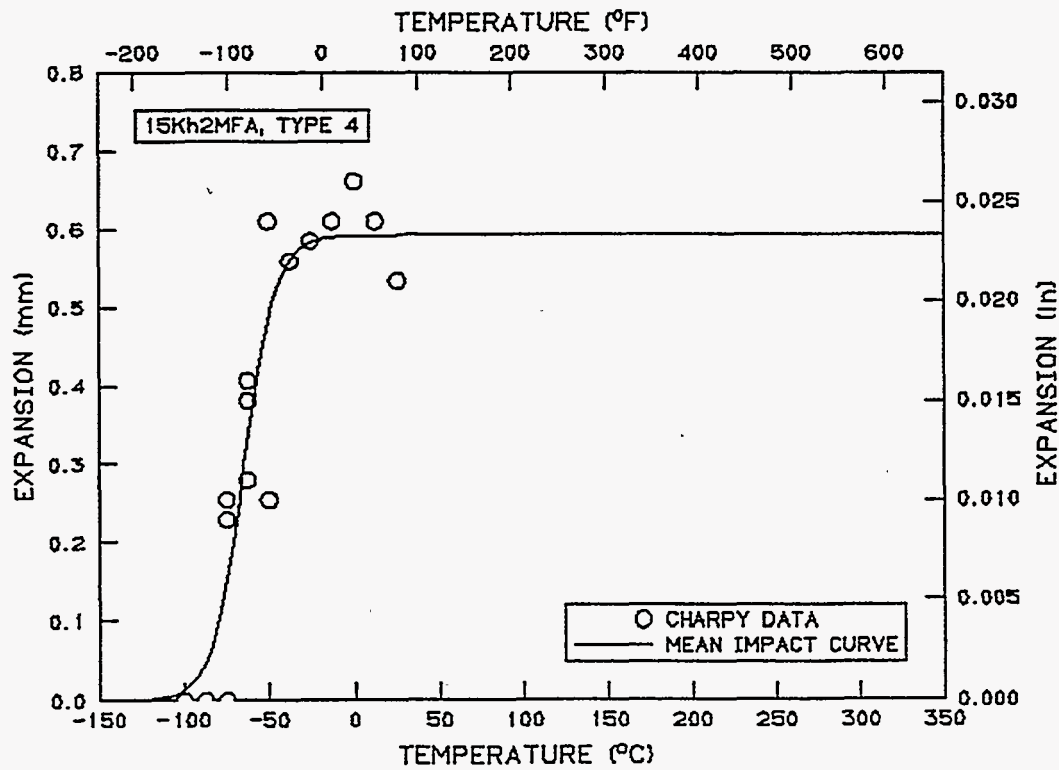

SOURCE: VVER440_.T4 ANALYSIS SET

Y VARIABLE: SHEAR

MODEL PARAMETERS

LOWER SHELF SHEAR [HELD FIXED]: 0 (PERCENT)

MID-TRANSITION TEMPERATURE:-54.9 (DEG C),-66.8 (DEG F)

TRANSITION ZONE WIDTH: 35.2 (C DEG),63.4 (F DEG)

UPPER SHELF SHEAR [HELD FIXED]: 100 (PERCENT)

UPPER SHELF SHEAR: 100 (PERCENT)

TEMPERATURE [50 (PERCENT),50 (PERCENT) SHEAR]:-54.9 (DEG C),-66.8 (DEG F)

NOTE: 15Kh2MFA, TYPE 4

MODEL SET NAME: 9

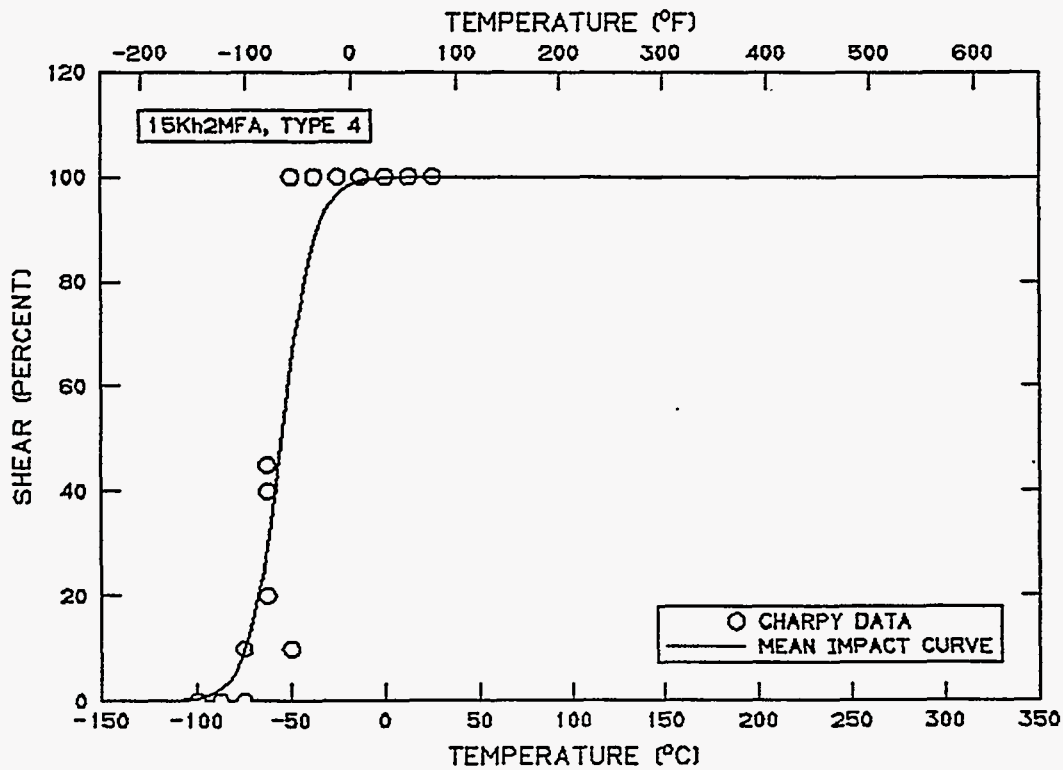

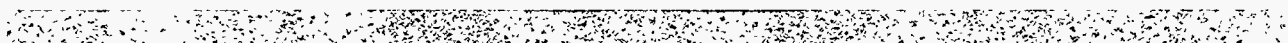

APPENDIX K
HSSI WELD 72W

SOURCE: ANALYSIS SET
ANALYSIS SET NAME: 72W.FUL

SET NAME: 72W.FUL
NOTE: NONE

IDENT	TEMPERATURE		ENERGY (J)	(FT-LB)	EXPANSION		SHEAR (PERCENT)
	(DEG C)	(DEG F)			(MM)	(IN)	
72W329	-74.0	-101.2	9.50	7.01	0.08	0.003	10.0
72W343	-74.0	-101.2	10.10	7.45	0.00	0.000	3.0
72W449	-48.0	-54.4	14.90	10.99	0.25	0.010	0.0
72W469	-48.0	-54.4	15.50	11.43	0.24	0.009	0.0
72W460	-48.0	-54.4	15.60	11.51	0.27	0.011	0.0
72W327	-48.0	-54.4	16.30	12.02	0.27	0.011	18.0
72W434	-48.0	-54.4	25.80	19.03	0.44	0.017	0.0
72W395	-48.0	-54.4	30.50	22.50	0.39	0.015	0.0
72W341	-32.0	-25.6	19.70	14.53	0.34	0.013	12.0
72W338	-32.0	-25.6	27.80	20.50	0.37	0.015	14.0
72W443	-24.0	-11.2	29.80	21.98	0.69	0.027	32.0
72W350	-24.0	-11.2	32.50	23.97	0.56	0.022	18.0
72W389	-24.0	-11.2	38.60	28.47	0.67	0.026	23.0
72W436	-24.0	-11.2	46.10	34.00	0.69	0.027	25.0
72W435	-24.0	-11.2	55.60	41.01	0.91	0.036	30.0
72W348	-24.0	-11.2	56.30	41.52	0.72	0.028	42.0
72W393	-24.0	-11.2	65.10	48.02	1.04	0.041	47.0
72W442	-24.0	-11.2	67.10	49.49	1.04	0.041	50.0
72W456	-24.0	-11.2	69.20	51.04	1.12	0.044	39.0
72W455	-24.0	-11.2	71.90	53.03	1.17	0.046	57.0
72W325	-18.0	-0.4	71.90	53.03	0.83	0.033	52.0
72W377	-4.0	24.8	23.70	17.48	0.60	0.024	44.0
72W359	-4.0	24.8	28.50	21.02	0.48	0.019	20.0
72W424	-4.0	24.8	35.90	26.48	1.02	0.040	47.0
72W357	-4.0	24.8	46.80	34.52	0.69	0.027	36.0
72W379	-4.0	24.8	59.70	44.03	0.97	0.038	39.0
72W336	-4.0	24.8	77.30	57.01	1.18	0.046	48.0
72W426	-4.0	24.8	78.60	57.97	1.32	0.052	53.0
72W437	-4.0	24.8	86.80	64.02	1.25	0.049	23.0
72W438	-4.0	24.8	86.80	64.02	1.45	0.057	43.0
72W461	-4.0	24.8	86.80	64.02	1.37	0.054	64.0
72W462	-4.0	24.8	92.20	68.00	1.52	0.060	69.0
72W323	10.0	50.0	107.10	78.99	1.47	0.058	70.0
72W451	21.0	69.8	50.80	37.47	1.00	0.039	56.0
72W375	21.0	69.8	66.40	48.97	1.14	0.045	38.0
72W371	21.0	69.8	88.80	65.50	1.36	0.054	73.0
72W414	21.0	69.8	96.30	71.03	1.60	0.063	60.0
72W444	21.0	69.8	101.00	74.49	1.68	0.066	79.0
72W452	21.0	69.8	108.50	80.03	1.78	0.070	78.0
72W301	21.0	69.8	109.80	80.98	1.52	0.060	25.0
72W468	21.0	69.8	111.20	82.02	1.83	0.072	82.0
72W418	21.0	69.8	112.50	82.98	1.78	0.070	84.0
72W404	21.0	69.8	114.60	84.52	1.65	0.065	80.0
72W445	21.0	69.8	122.00	89.98	2.13	0.084	88.0
72W303	38.0	100.4	134.20	98.98	1.83	0.072	95.0
72W305	66.0	150.8	135.60	100.01	1.79	0.070	95.0
72W473	80.0	176.0	108.50	80.03	1.60	0.063	86.0
72W447	80.0	176.0	122.00	89.98	2.01	0.079	100.0
72W472	80.0	176.0	124.70	91.97	1.97	0.078	96.0
72W446	80.0	176.0	130.80	96.47	2.21	0.087	100.0
72W387	80.0	176.0	133.50	98.46	2.10	0.083	100.0

72W454	80.0	176.0	135.60	100.01	2.18	0.086	100.0
72W430	80.0	176.0	136.90	100.97	2.39	0.094	100.0
72W397	80.0	176.0	138.30	102.00	2.08	0.082	100.0
72W453	80.0	176.0	139.60	102.96	2.21	0.087	100.0
72W420	80.0	176.0	141.00	104.00	2.41	0.095	100.0
72W307	93.0	199.4	136.90	100.97	1.89	0.074	100.0
72W355	140.0	284.0	124.70	91.97	2.11	0.083	100.0
72W385	140.0	284.0	127.40	93.97	2.03	0.080	100.0
72W349	140.0	284.0	130.80	96.47	2.13	0.084	100.0
72W458	140.0	284.0	132.90	98.02	2.06	0.081	100.0
72W470	140.0	284.0	134.20	98.98	2.20	0.087	100.0
72W457	140.0	284.0	135.60	100.01	2.29	0.090	100.0
72W471	140.0	284.0	136.90	100.97	2.06	0.081	100.0
72W361	140.0	284.0	136.90	100.97	2.01	0.079	100.0
72W440	140.0	284.0	136.90	100.97	2.34	0.092	100.0
72W381	140.0	284.0	148.50	109.53	2.31	0.091	100.0
72W309	149.0	300.2	134.90	99.50	2.05	0.081	100.0
72W450	190.0	374.0	113.90	84.01	1.78	0.070	100.0
72W448	190.0	374.0	122.70	90.50	2.12	0.083	100.0
72W475	190.0	374.0	127.40	93.97	2.06	0.081	100.0
72W474	190.0	374.0	129.50	95.51	2.21	0.087	100.0
72W408	190.0	374.0	138.30	102.00	2.08	0.082	100.0
72W464	190.0	374.0	138.30	102.00	1.80	0.071	100.0
72W463	190.0	374.0	141.70	104.51	2.41	0.095	100.0
72W441	190.0	374.0	142.40	105.03	2.26	0.089	100.0
72W432	190.0	374.0	143.00	105.47	2.06	0.081	100.0
72W406	190.0	374.0	143.00	105.47	2.18	0.086	100.0
72W465	288.0	550.4	135.60	100.01	1.94	0.076	100.0
72W466	288.0	550.4	136.30	100.53	1.97	0.078	100.0
72W412	288.0	550.4	140.30	103.48	2.03	0.080	100.0
72W459	288.0	550.4	141.00	104.00	2.13	0.084	100.0
72W321	288.0	550.4	142.40	105.03	2.24	0.088	100.0
72W467	288.0	550.4	147.80	109.01	2.22	0.087	100.0

NUMBER OF SPECIMENS: 84

SOURCE: 72W.FUL ANALYSIS SET

Y VARIABLE: ENERGY

MODEL PARAMETERS

LOWER SHELF ENERGY [HELD FIXED]: 2.7 (J), 2.0 (FT-LB)

MID-TRANSITION TEMPERATURE: -4.5 (DEG C), 23.9 (DEG F)

TRANSITION ZONE WIDTH: 103.7 (C DEG), 186.6 (F DEG)

UPPER SHELF ENERGY: 136.3 (J), 100.5 (FT-LB)

UPPER SHELF ENERGY: 136.3 (J), 100.5 (FT-LB)

TEMPERATURE [41 (J), 30.2 (FT-LB) ENERGY]: -28.1 (DEG C), -18.6 (DEG F)

TEMPERATURE [68 (J), 50.2 (FT-LB) ENERGY]: -5.7 (DEG C), 21.8 (DEG F)

NOTE: NONE

MODEL SET NAME: 9

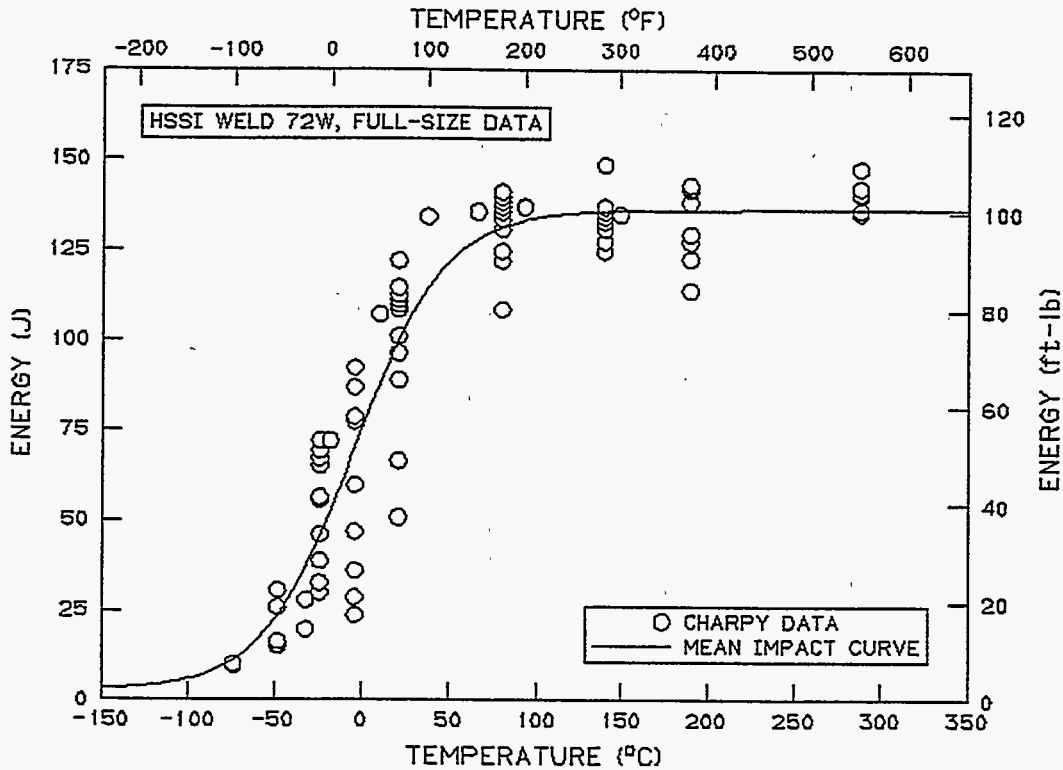

SOURCE: 72W.FUL ANALYSIS SET

Y VARIABLE: EXPANSION

MODEL PARAMETERS

LOWER SHELF EXPANSION [HELD FIXED]: 0.061 (MM), 0.0024 (IN)

MID-TRANSITION TEMPERATURE: -5.7 (DEG C), 21.7 (DEG F)

TRANSITION ZONE WIDTH: 98.6 (C DEG), 177.4 (F DEG)

UPPER SHELF EXPANSION: 2.119 (MM), 0.0834 (IN)

UPPER SHELF EXPANSION: 2.119 (MM), 0.0834 (IN)

NOTE: NONE

MODEL SET NAME: 0

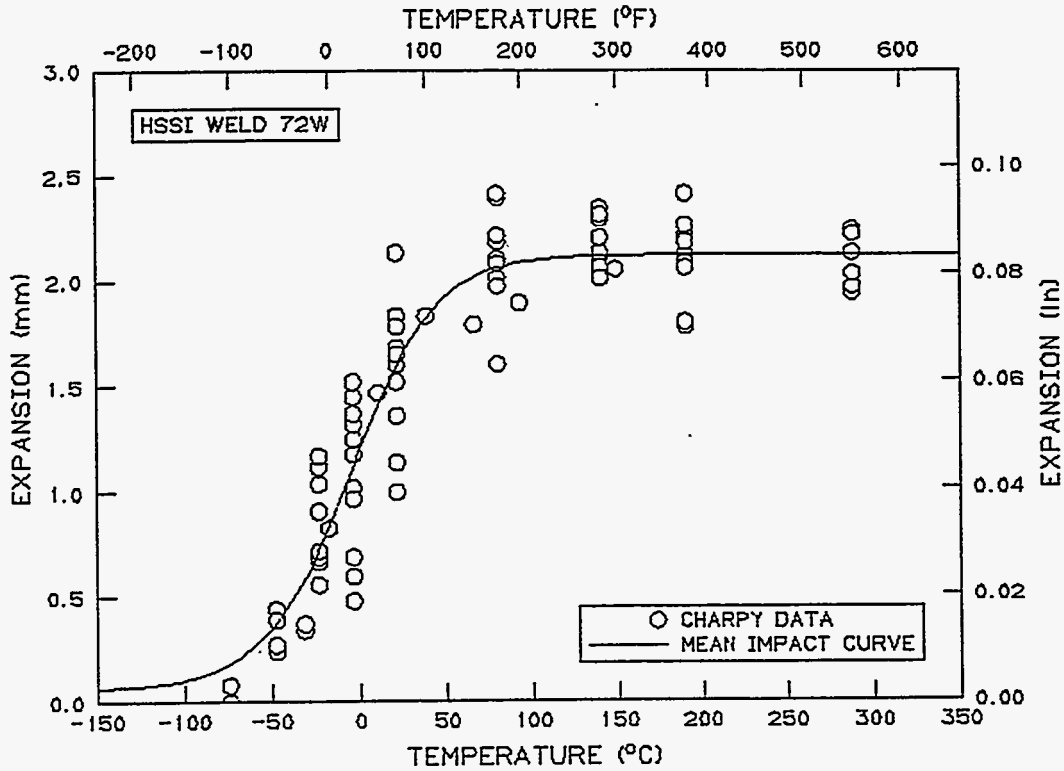

SOURCE: 72W.FUL ANALYSIS SET

Y VARIABLE: SHEAR

MODEL PARAMETERS

LOWER SHELF SHEAR [HELD FIXED]: 0 (PERCENT)

MID-TRANSITION TEMPERATURE:-1.0 (DEG C),30.2 (DEG F)

TRANSITION ZONE WIDTH: 99.6 (C DEG),179.2 (F DEG)

UPPER SHELF SHEAR [HELD FIXED]: 100 (PERCENT)

UPPER SHELF SHEAR: 100 (PERCENT)

NOTE: NONE

MODEL SET NAME: 10

DESTINATION FILE NAME: 1

DESTINATION DIRECTORY PATH: C:\USER\

MODEL VARIABLES SAVED

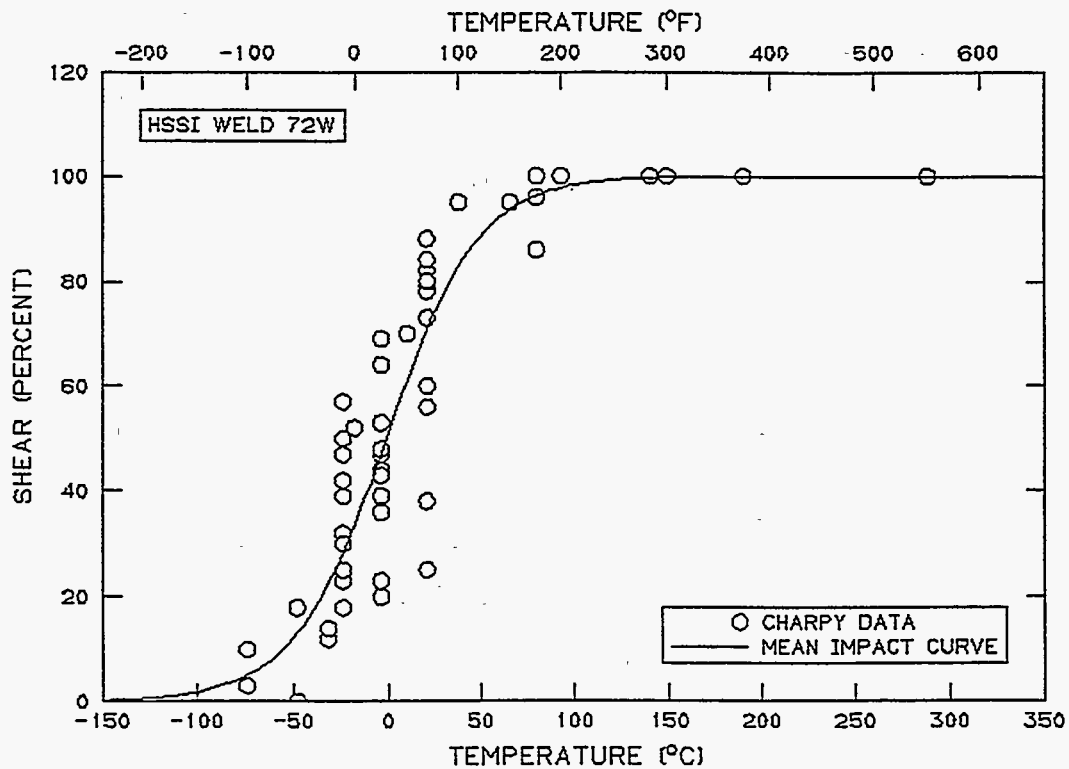

SOURCE: ANALYSIS SET
ANALYSIS SET NAME: 72W_T1

SET NAME: 72W_T1

NOTE: HSSI WELD 72W SPECIMEN TYPE 1

IDENT	TEMPERATURE		ENERGY (J)	EXPANSION		SHEAR (PERCENT)	
	(DEG C)	(DEG F)		(FT-LB)	(MM)		(IN)
7W1G	-112.5	-170.5	1.45	1.07	0.00	0.000	0.0
7W1F	-100.0	-148.0	0.66	0.49	0.00	0.000	0.0
7W1H	-87.5	-125.5	4.75	3.50	0.03	0.001	5.0
7W1E	-75.0	-103.0	10.21	7.53	0.36	0.014	10.0
7W1I	-62.5	-80.5	3.59	2.65	0.08	0.003	10.0
7W1D	-50.0	-58.0	13.31	9.82	0.48	0.019	45.0
7W1J	-37.5	-35.5	12.35	9.11	0.48	0.019	50.0
7W1C	-25.0	-13.0	8.09	5.97	0.38	0.015	65.0
7W1K	-12.5	9.5	16.70	12.32	0.69	0.027	75.0
7W1B	0.0	32.0	18.21	13.43	0.74	0.029	75.0
7W1L	12.5	54.5	21.02	15.50	0.91	0.036	90.0
7W1A	25.0	77.0	20.66	15.24	0.91	0.036	85.0
7W1M	50.0	122.0	22.19	16.37	0.89	0.035	100.0
7W1N	100.0	212.0	22.80	16.82	0.91	0.036	100.0
7W1P	150.0	302.0	24.55	18.11	0.99	0.039	100.0
7W1O	200.0	392.0	22.47	16.57	0.91	0.036	100.0

NUMBER OF SPECIMENS: 16

SOURCE: 72W_T1 ANALYSIS SET

Y VARIABLE: ENERGY

MODEL PARAMETERS

LOWER SHELF ENERGY [HELD FIXED]: 0.1 (J), 0.1 (FT-LB)

MID-TRANSITION TEMPERATURE: -36.2 (DEG C), -33.1 (DEG F)

TRANSITION ZONE WIDTH: 131.9 (C DEG), 237.4 (F DEG)

UPPER SHELF ENERGY: 23.7 (J), 17.5 (FT-LB)

UPPER SHELF ENERGY: 23.7 (J), 17.5 (FT-LB)

NOTE: HSSI WELD 72W, TYPE 1

MODEL SET NAME: 1

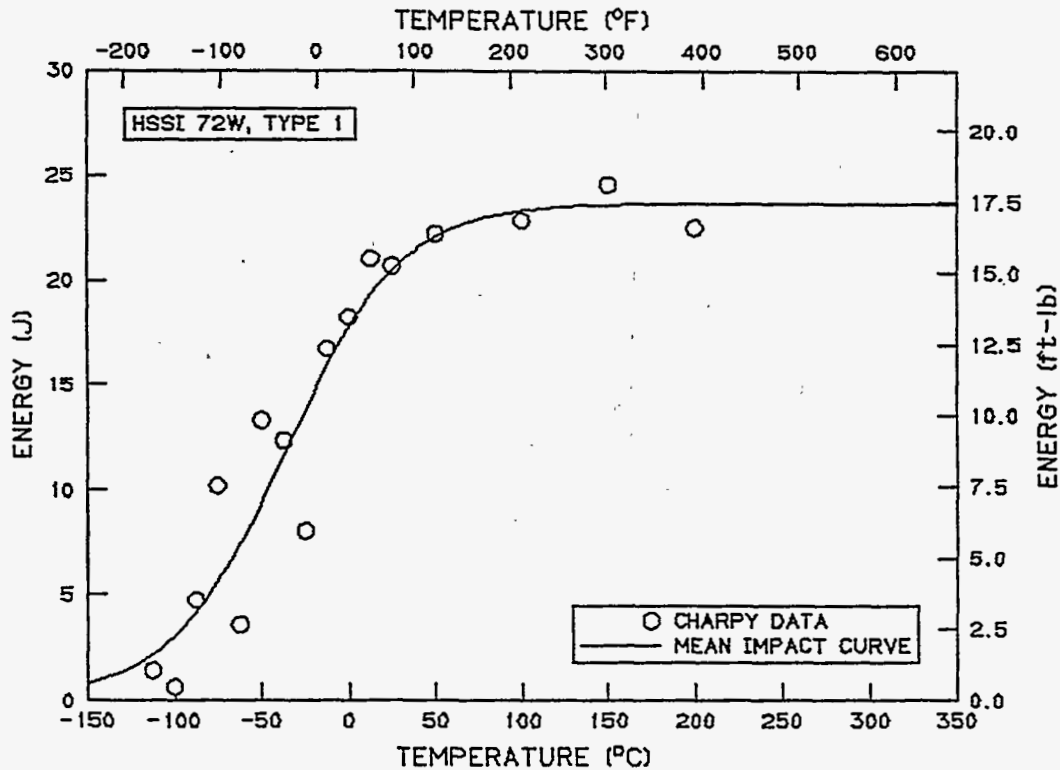

SOURCE: 72W_T1 ANALYSIS SET

Y VARIABLE: EXPANSION

MODEL PARAMETERS

LOWER SHELF EXPANSION [HELD FIXED]: 0.000 (MM), 0.0000 (IN)

MID-TRANSITION TEMPERATURE: -34.1 (DEG C), -29.4 (DEG F)

TRANSITION ZONE WIDTH: 99.7 (C DEG), 179.4 (F DEG)

UPPER SHELF EXPANSION: 0.951 (MM), 0.0375 (IN)

UPPER SHELF EXPANSION: 0.951 (MM), 0.0375 (IN)

NOTE: HSSI WELD 72W, TYPE 1

MODEL SET NAME: 2

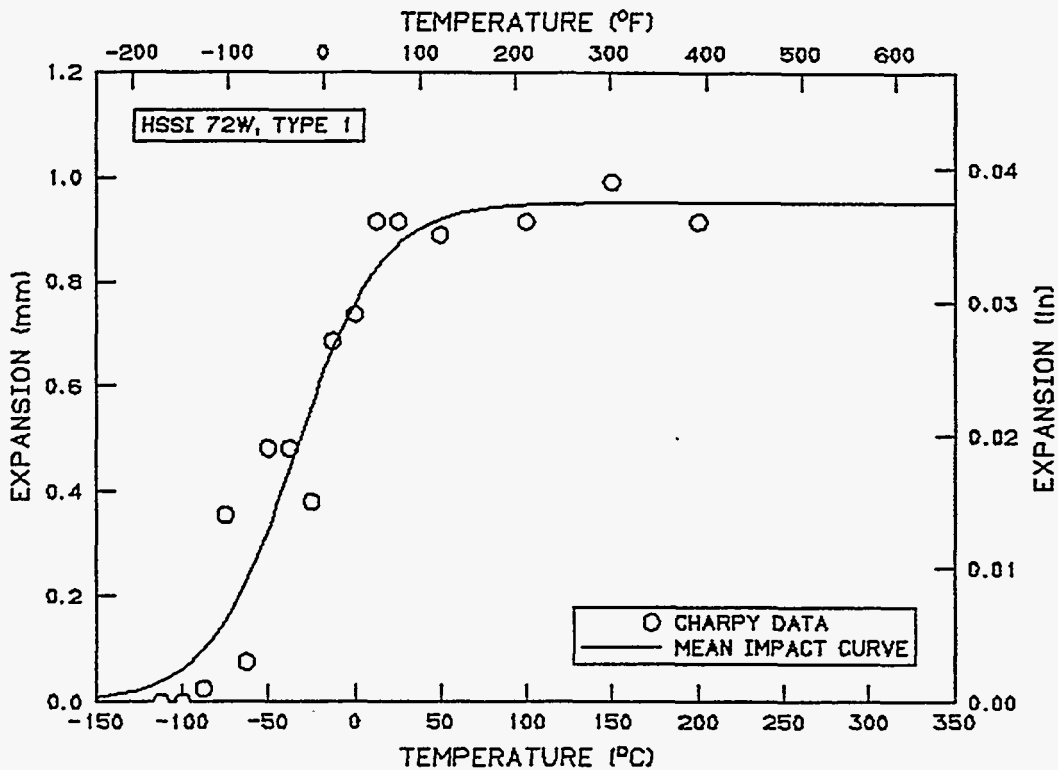

SOURCE: 72W_T1 ANALYSIS SET

Y VARIABLE: SHEAR

MODEL PARAMETERS

LOWER SHELF SHEAR [HELD FIXED]: 0 (PERCENT)

MID-TRANSITION TEMPERATURE:-34.9 (DEG C), -30.8 (DEG F)

TRANSITION ZONE WIDTH: 85.6 (C DEG), 154.0 (F DEG)

UPPER SHELF SHEAR [HELD FIXED]: 100 (PERCENT)

UPPER SHELF SHEAR: 100 (PERCENT)

TEMPERATURE [50 (PERCENT), 50 (PERCENT) SHEAR]: -34.9 (DEG C), -30.8 (DEG F)

NOTE: HSSI WELD 72W, TYPE 1

MODEL SET NAME: 3

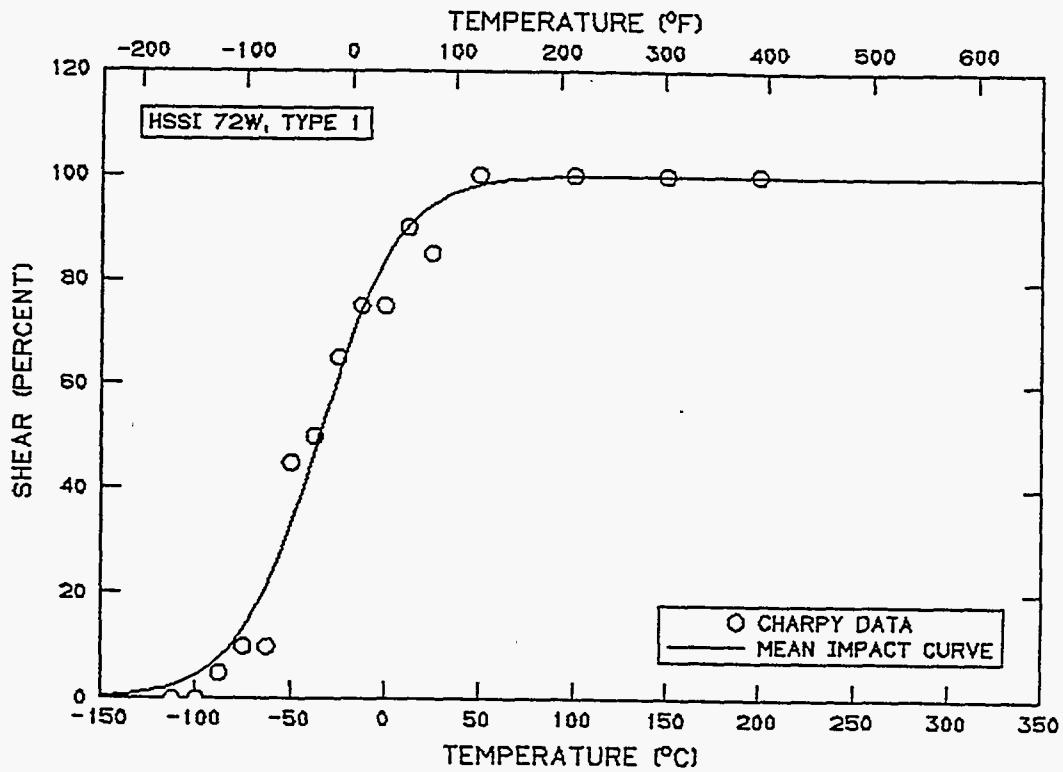

SOURCE: ANALYSIS SET
ANALYSIS SET NAME: 72W_T2

SET NAME: 72W_T2
NOTE: 72W TYPE 2 SPECIMENS

IDENT	TEMPERATURE		ENERGY (J)	(FT-LB)	EXPANSION		SHEAR (PERCENT)
	(DEG C)	(DEG F)			(MM)	(IN)	
7W2H	-125.0	-193.0	0.14	0.10	0.00	0.000	0.0
7W2G	-112.5	-170.5	2.16	1.59	0.05	0.002	0.0
7W2F	-100.0	-148.0	1.57	1.16	0.00	0.000	0.0
7W2I	-87.5	-125.5	0.79	0.58	0.00	0.000	0.0
7W2E	-75.0	-103.0	0.99	0.73	0.00	0.000	0.0
7W2P	-75.0	-103.0	4.23	3.12	0.28	0.011	20.0
7W2J	-62.5	-80.5	4.75	3.50	0.33	0.013	40.0
7W2D	-50.0	-58.0	5.64	4.16	0.36	0.014	70.0
7W2K	-37.5	-35.5	6.02	4.44	0.41	0.016	80.0
7W2C	-25.0	-13.0	6.52	4.81	0.51	0.020	90.0
7W2L	-12.5	9.5	7.21	5.32	0.43	0.017	90.0
7W2B	0.0	32.0	7.28	5.37	0.61	0.024	100.0
7W2M	12.5	54.5	7.40	5.46	0.56	0.022	95.0
7W2A	25.0	77.0	7.73	5.70	0.56	0.022	100.0
7W2N	37.5	99.5	7.54	5.56	0.64	0.025	100.0
7W2O	100.0	212.0	7.85	5.79	0.66	0.026	100.0

NUMBER OF SPECIMENS: 16

SOURCE: 72W_T2 ANALYSIS SET

Y VARIABLE: ENERGY

MODEL PARAMETERS

LOWER SHELF ENERGY [HELD FIXED]: 0.1 (J), 0.1 (FT-LB)

MID-TRANSITION TEMPERATURE: -64.6 (DEG C), -84.3 (DEG F)

TRANSITION ZONE WIDTH: 79.1 (C DEG), 142.4 (F DEG)

UPPER SHELF ENERGY: 7.7 (J), 5.7 (FT-LB)

UPPER SHELF ENERGY: 7.7 (J), 5.7 (FT-LB)

NOTE: HSSI WELD 72W, TYPE 2

MODEL SET NAME: 6

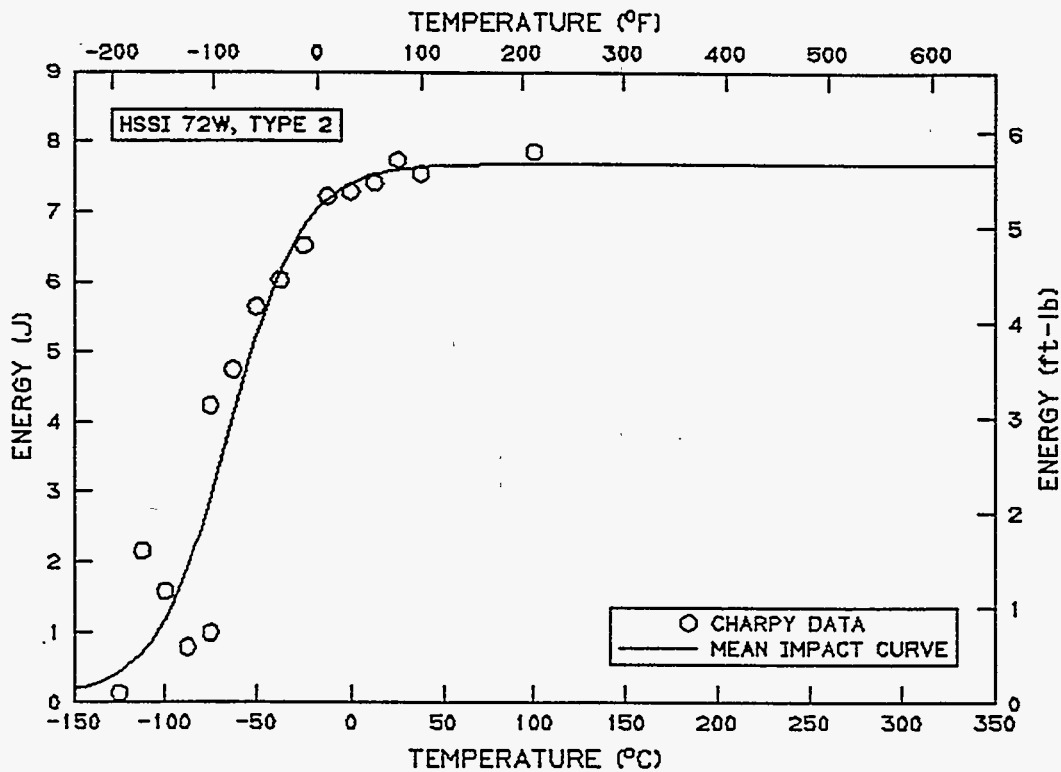

SOURCE: 72W_T2 ANALYSIS SET

Y VARIABLE: EXPANSION

MODEL PARAMETERS

LOWER SHELF EXPANSION [HELD FIXED]: 0.000 (MM), 0.0000 (IN)

MID-TRANSITION TEMPERATURE: -54.2 (DEG C), -65.6 (DEG F)

TRANSITION ZONE WIDTH: 74.7 (C DEG), 134.5 (F DEG)

UPPER SHELF EXPANSION: 0.601 (MM), 0.0237 (IN)

UPPER SHELF EXPANSION: 0.601 (MM), 0.0237 (IN)

NOTE: HSSI WELD 72W, TYPE 2

MODEL SET NAME: 5

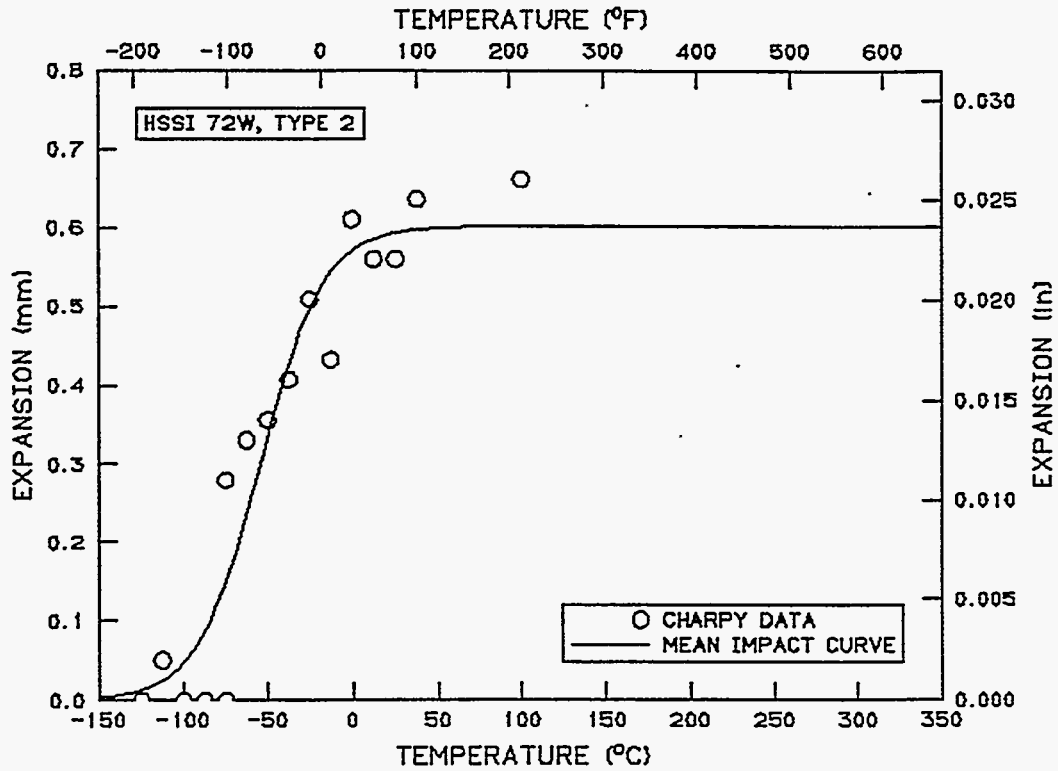

SOURCE: 72W_T2 ANALYSIS SET

Y VARIABLE: SHEAR

MODEL PARAMETERS

LOWER SHELF SHEAR [HELD FIXED]: 0 (PERCENT)

MID-TRANSITION TEMPERATURE:-56.3 (DEG C),-69.3 (DEG F)

TRANSITION ZONE WIDTH: 41.4 (C DEG),74.4 (F DEG)

UPPER SHELF SHEAR [HELD FIXED]: 100 (PERCENT)

UPPER SHELF SHEAR: 100 (PERCENT)

TEMPERATURE [50 (PERCENT),50 (PERCENT) SHEAR]:-56.3 (DEG C),-69.3 (DEG F)

NOTE: HSSI WELD 72W, TYPE 2

MODEL SET NAME: 4

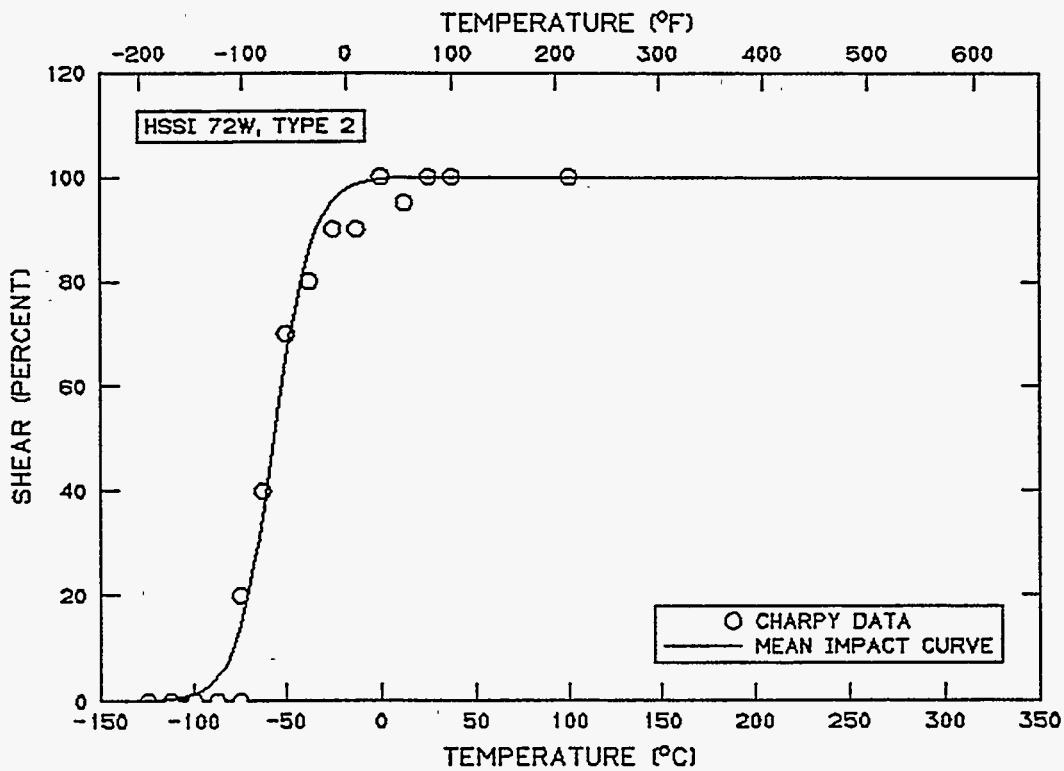

SOURCE: ANALYSIS SET
 ANALYSIS SET NAME: 72W_T3

SET NAME: 72W T3

NOTE: SUB-SIZE CORRELATION PROGRAM, TYPE 3 SPEC., PLATE 72W

IDENT	TEMPERATURE		ENERGY (J)	EXPANSION			SHEAR (PERCENT)
	(DEG C)	(DEG F)		(FT-LB)	(MM)	(IN)	
7W3I	-137.5	-215.5	0.92	0.68	0.00	0.000	0.0
7W3G	-125.0	-193.0	1.26	0.93	0.00	0.000	0.0
7W3H	-112.5	-170.5	6.89	5.08	0.18	0.007	5.0
7W3F	-100.0	-148.0	4.84	3.57	0.08	0.003	0.0
7W3J	-91.5	-132.7	10.09	7.44	0.36	0.014	15.0
7W3E	-75.0	-103.0	9.08	6.70	0.30	0.012	0.0
7W3K	-62.5	-80.5	11.93	8.80	0.56	0.022	35.0
7W3D	-50.0	-58.0	11.75	8.67	0.51	0.020	45.0
7W3L	-37.5	-35.5	11.93	8.80	0.53	0.021	60.0
7W3C	-25.0	-13.0	13.45	9.92	0.58	0.023	65.0
7W3M	-12.5	9.5	16.03	11.82	0.74	0.029	85.0
7W3B	0.0	32.0	16.74	12.35	0.71	0.028	80.0
7W3N	12.5	54.5	19.43	14.33	0.76	0.030	100.0
7W3A	25.0	77.0	20.00	14.75	0.81	0.032	100.0
7W3O	100.0	212.0	20.23	14.92	0.79	0.031	100.0
7W3O	100.0	212.0	20.23	14.92	0.79	0.031	100.0
7W3R	150.0	302.0	20.91	15.42	0.89	0.035	100.0
7W3R	150.0	302.0	20.91	15.42	0.89	0.035	100.0
7W3P	200.0	392.0	24.27	17.90	0.97	0.038	100.0
7W3Q	250.0	482.0	25.15	18.55	0.76	0.030	100.0

NUMBER OF SPECIMENS: 20

SOURCE: 72W_T3 ANALYSIS SET

Y VARIABLE: ENERGY

MODEL PARAMETERS

LOWER SHELF ENERGY [HELD FIXED]: 0.1 (J), 0.1 (FT-LB)

MID-TRANSITION TEMPERATURE: -54.3 (DEG C), -65.7 (DEG F)

TRANSITION ZONE WIDTH: 183.4 (C DEG), 330.2 (F DEG)

UPPER SHELF ENERGY: 22.5 (J), 16.6 (FT-LB)

UPPER SHELF ENERGY: 22.5 (J), 16.6 (FT-LB)

NOTE: HSSI WELD 72W, TYPE 3

MODEL SET NAME: 7

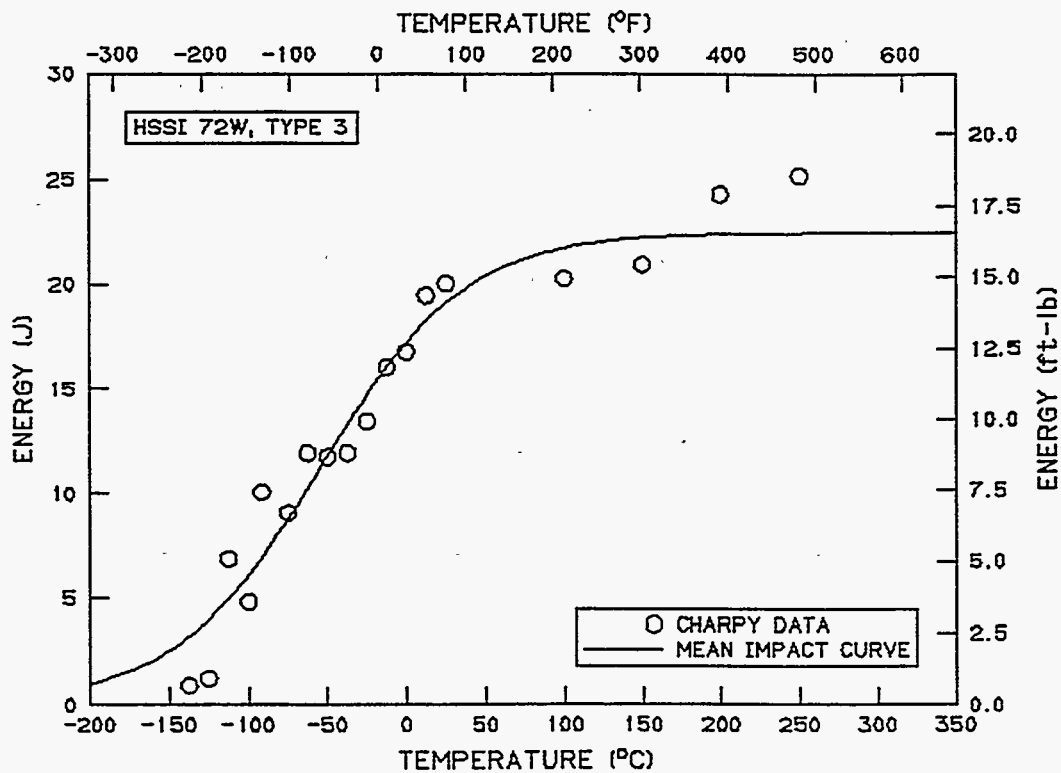

SOURCE: 72W_T3 ANALYSIS SET

Y VARIABLE: EXPANSION

MODEL PARAMETERS

LOWER SHELF EXPANSION [HELD FIXED]: 0.000 (MM), 0.0000 (IN)

MID-TRANSITION TEMPERATURE: -62.6 (DEG C), -80.6 (DEG F)

TRANSITION ZONE WIDTH: 121.4 (C DEG), 218.5 (F DEG)

UPPER SHELF EXPANSION: 0.842 (MM), 0.0331 (IN)

UPPER SHELF EXPANSION: 0.842 (MM), 0.0331 (IN)

NOTE: HSSI WELD 72W, TYPE 3

MODEL SET NAME: 8

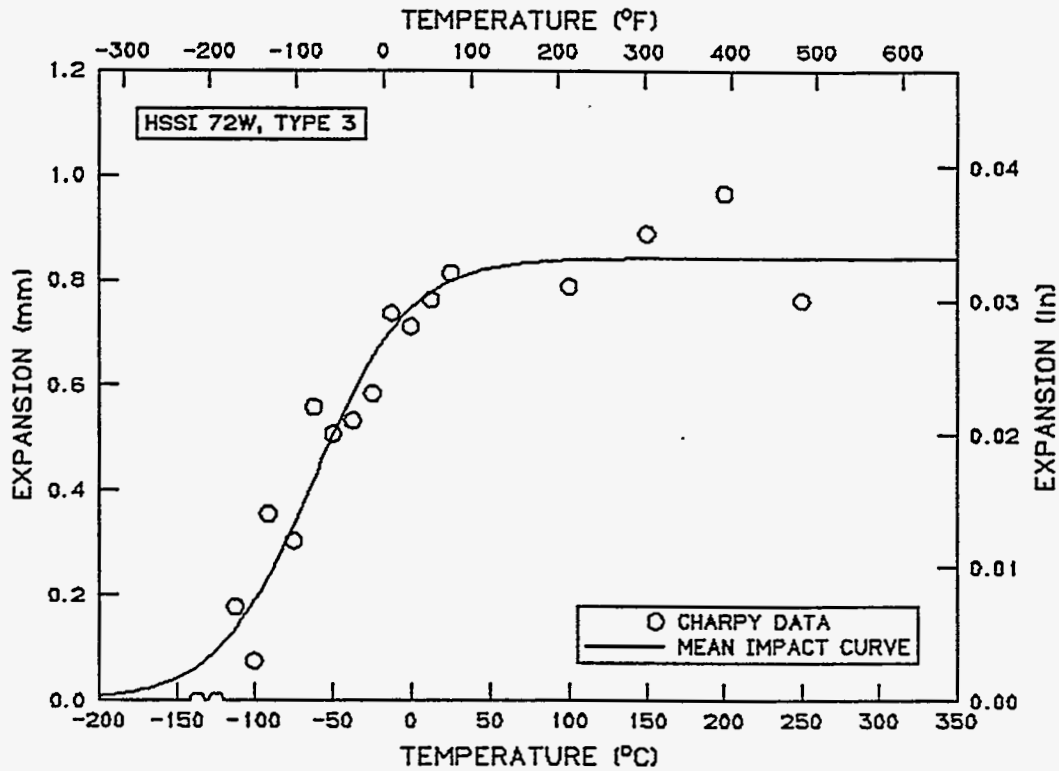

SOURCE: 72W_T3 ANALYSIS SET

Y VARIABLE: SHEAR

MODEL PARAMETERS

LOWER SHELF SHEAR [HELD FIXED]: 0 (PERCENT)

MID-TRANSITION TEMPERATURE:-42.9 (DEG C),-45.1 (DEG F)

TRANSITION ZONE WIDTH: 78.9 (C DEG),141.9 (F DEG)

UPPER SHELF SHEAR [HELD FIXED]: 100 (PERCENT)

UPPER SHELF SHEAR: 100 (PERCENT)

TEMPERATURE [50 (PERCENT),50 (PERCENT) SHEAR]:-42.9 (DEG C),-45.1 (DEG F)

NOTE: HSSI WELD 72W, TYPE 3

MODEL SET NAME: 9

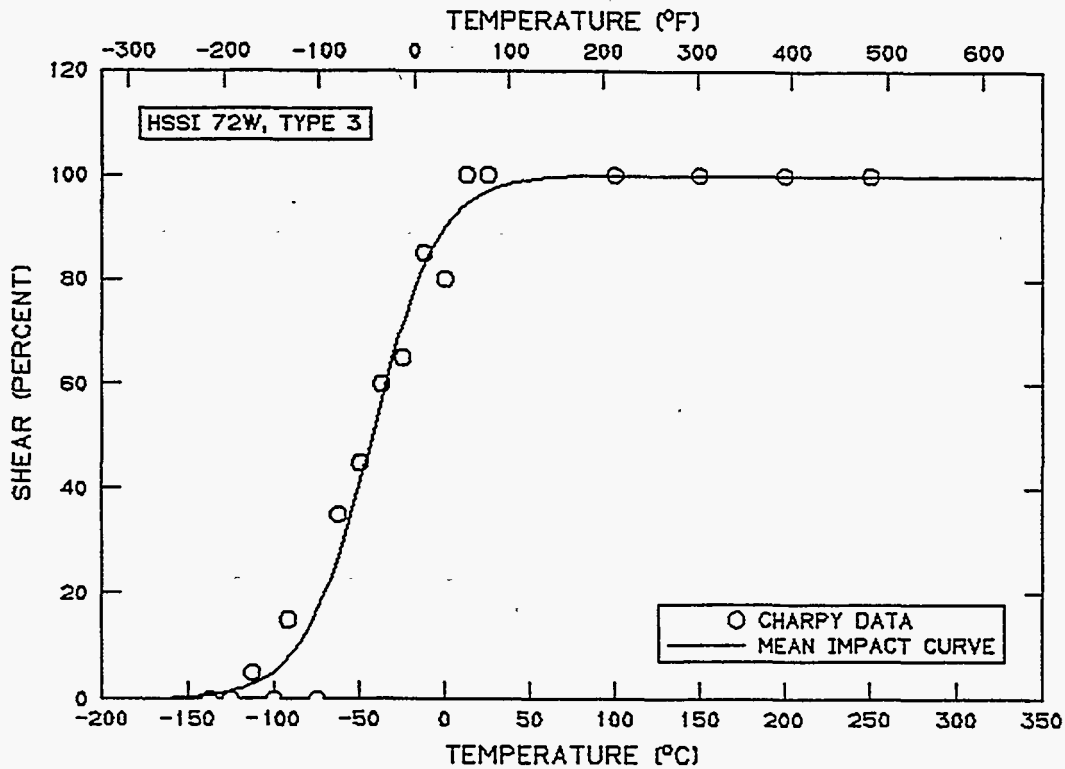

SOURCE: ANALYSIS SET
 ANALYSIS SET NAMES: 72W_T4 AND 72WT4FUL

SET NAME: 72W T4
 NOTE: SUB-SIZE CORRELATION PROGRAM, 72W, SPECIMEN TYPE 4

IDENT	TEMPERATURE		ENERGY		EXPANSION		SHEAR (PERCENT)
	(DEG C)	(DEG F)	(J)	(FT-LB)	(MM)	(IN)	
7W4F	-100.0	-148.0	0.90	0.66	0.00	0.000	0.0
7W4G	-87.5	-125.5	1.60	1.18	0.00	0.000	0.0
7W4E	-75.0	-103.0	0.70	0.52	0.00	0.000	5.0
7W4H	-75.0	-103.0	0.80	0.59	0.00	0.000	5.0
7W4I	-62.5	-80.5	2.80	2.07	0.20	0.008	30.0
7W4D	-50.0	-58.0	2.60	1.92	0.20	0.008	25.0
7W4J	-50.0	-58.0	4.00	2.95	0.36	0.014	70.0
7W4K	-37.5	-35.5	5.90	4.35	0.51	0.020	100.0
7W4C	-25.0	-13.0	6.10	4.50	0.48	0.019	100.0
7W4L	-25.0	-13.0	6.20	4.57	0.48	0.019	100.0
7W4B	0.0	32.0	5.50	4.06	0.74	0.029	100.0
7W4A	25.0	77.0	5.50	4.06	0.51	0.020	100.0
7W4M	100.0	212.0	5.50	4.06	0.53	0.021	100.0

NUMBER OF SPECIMENS: 13

SET NAME: 72WT4FUL
 NOTE: 72W TYPE 4 SPECIMENS TESTED WITH HAMMER AT FULL HEIGHT

IDENT	TEMPERATURE		ENERGY		EXPANSION		SHEAR (PERCENT)
	(DEG C)	(DEG F)	(J)	(FT-LB)	(MM)	(IN)	
7W4N	-75.0	-103.0	1.87	1.38	0.05	0.002	5.0
7W4O	-62.5	-80.5	3.12	2.30	0.23	0.009	20.0
7W4P	-50.0	-58.0	3.47	2.56	0.25	0.010	40.0
7W4Q	-25.0	-13.0	4.24	3.13	0.36	0.014	80.0
7W4Q	100.0	212.0	5.45	4.02	0.56	0.022	100.0

NUMBER OF SPECIMENS: 5

SOURCE: 72W_T4 AND 72WT4FUL ANALYSIS SETS

Y VARIABLE: ENERGY

MODEL PARAMETERS

LOWER SHELF ENERGY [HELD FIXED]: 0.1 (J), 0.1 (FT-LB)

MID-TRANSITION TEMPERATURE: -59.4 (DEG C), -74.9 (DEG F)

TRANSITION ZONE WIDTH: 53.1 (C DEG), 95.6 (F DEG)

UPPER SHELF ENERGY: 5.7 (J), 4.2 (FT-LB)

UPPER SHELF ENERGY: 5.7 (J), 4.2 (FT-LB)

NOTE: HSSI WELD 72W, TYPE 4, 2.25 AND 5.5 M/S

MODEL SET NAME: 2

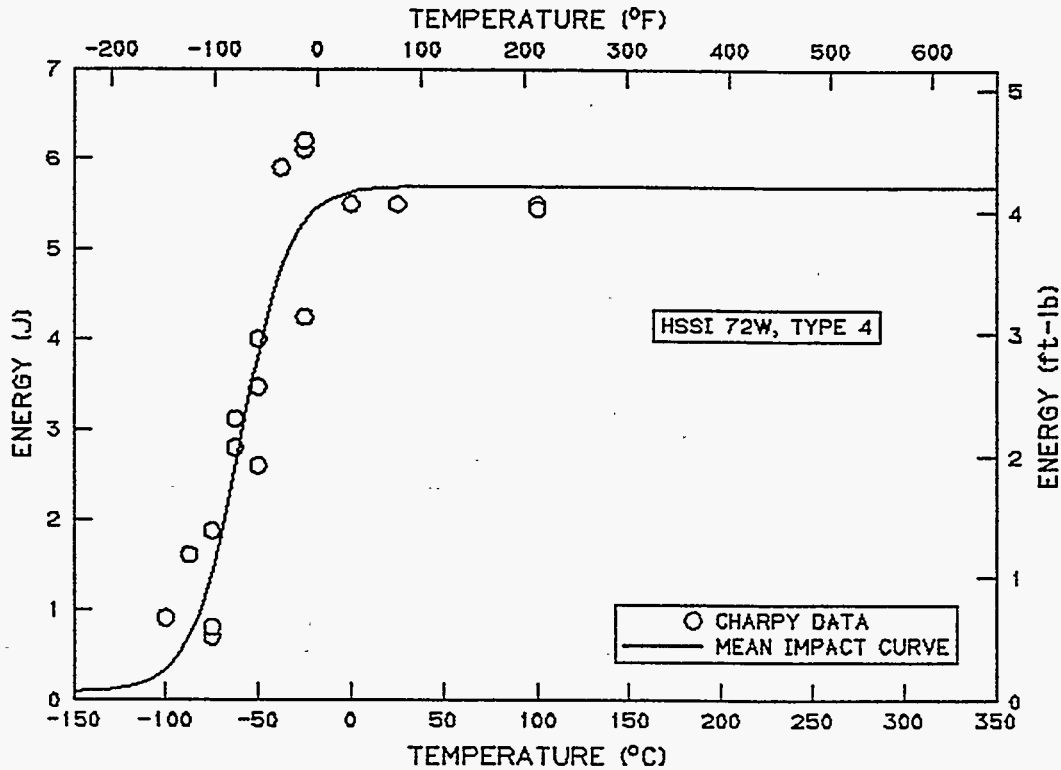

SOURCE: 72W_T4 AND 72WT4FUL ANALYSIS SETS

Y VARIABLE: EXPANSION

MODEL PARAMETERS

LOWER SHELF EXPANSION [HELD FIXED]: 0.000 (MM), 0.0000 (IN)

MID-TRANSITION TEMPERATURE: -50.6 (DEG C), -59.0 (DEG F)

TRANSITION ZONE WIDTH: 48.0 (C DEG), 86.4 (F DEG)

UPPER SHELF EXPANSION: 0.560 (MM), 0.0221 (IN)

UPPER SHELF EXPANSION: 0.560 (MM), 0.0221 (IN)

NOTE: HSSI WELD 72W, TYPE 4, 2.25 AND 5.5 M/S

MODEL SET NAME: 1

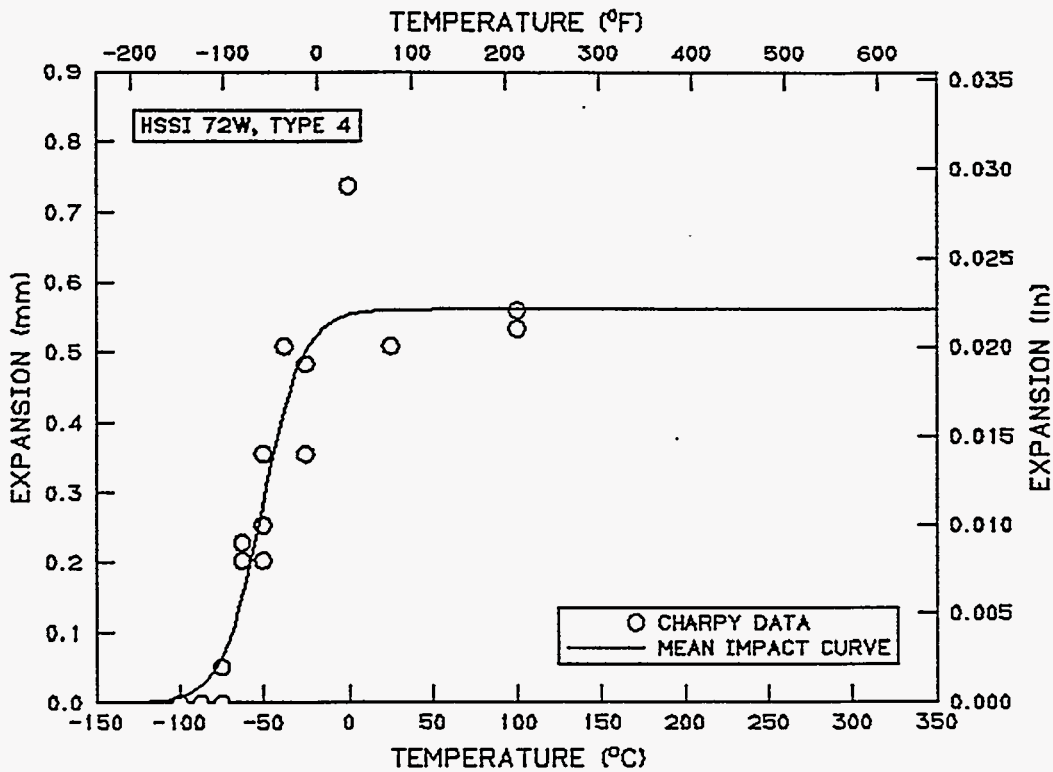

SOURCE: 72W_T4 AND 72WT4FUL ANALYSIS SETS

Y VARIABLE: SHEAR

MODEL PARAMETERS

LOWER SHELF SHEAR [HELD FIXED]: 0 (PERCENT)

MID-TRANSITION TEMPERATURE:-50.2 (DEG C),-58.4 (DEG F)

TRANSITION ZONE WIDTH: 33.0 (C DEG),59.5 (F DEG)

UPPER SHELF SHEAR [HELD FIXED]: 100 (PERCENT)

UPPER SHELF SHEAR: 100 (PERCENT)

TEMPERATURE [50 (PERCENT),50 (PERCENT) SHEAR]:-50.2 (DEG C),-58.4 (DEG F)

NOTE: HSSI 72W, TYPE 4, 2.25 AND 5.5 M/S

MODEL SET NAME: 10

DESTINATION FILE NAME: 10

DESTINATION DIRECTORY PATH: C:\USER\

MODEL VARIABLES SAVED

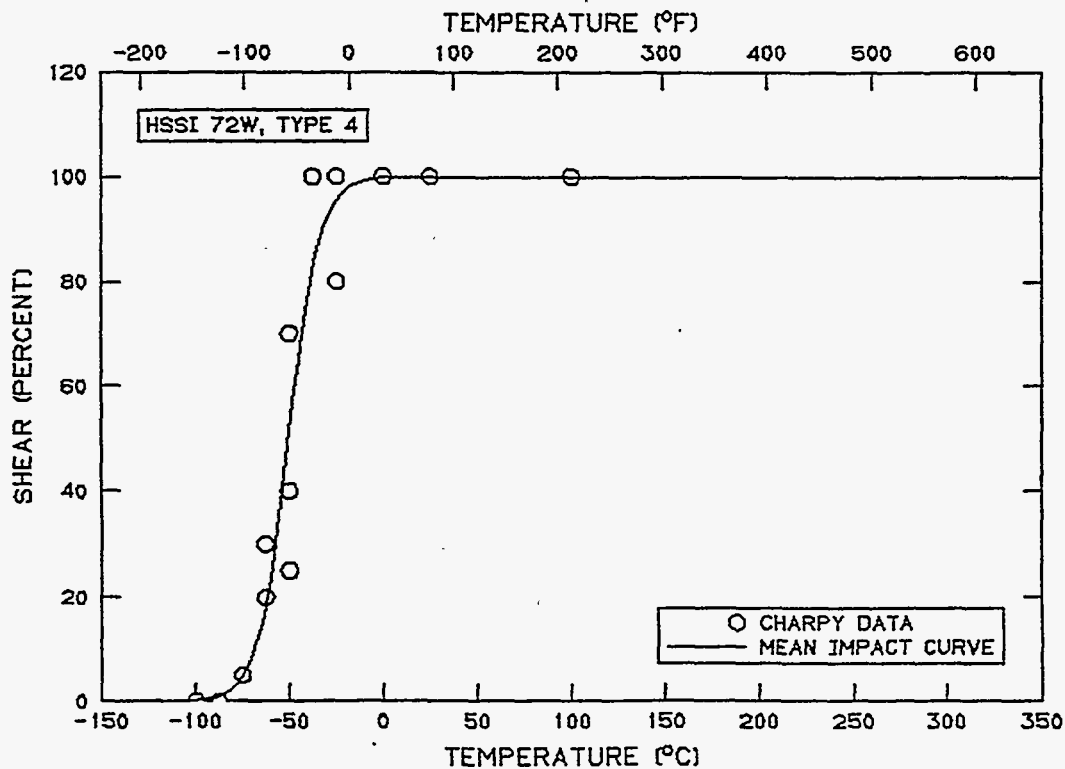

SOURCE: ANALYSIS SET
ANALYSIS SET NAME: 72W_T5

SET NAME: 72W_T5

NOTE: SUB-SIZE CORRELATION PROG., 72W, TYPE 5 SPECIMEN

IDENT	TEMPERATURE		ENERGY (J)	EXPANSION (FT-LB)	EXPANSION (MM)	EXPANSION (IN)	SHEAR (PERCENT)
	(DEG C)	(DEG F)					
7W5L	-125.0	-193.0	0.83	0.61	UNKNOWN		0.0
7W5F	-103.3	-154.0	0.96	0.71	UNKNOWN		0.0
7W5G	-100.0	-148.0	2.83	2.09	UNKNOWN		0.0
7W5M	-87.5	-125.5	7.93	5.85	UNKNOWN		5.0
7W5E	-75.0	-103.0	8.37	6.17	UNKNOWN		5.0
7W5H	-75.0	-103.0	10.52	7.76	UNKNOWN		10.0
7W5N	-62.5	-80.5	11.40	8.41	UNKNOWN		20.0
7W5D	-50.0	-58.0	11.54	8.51	UNKNOWN		45.0
7W5I	-50.0	-58.0	11.32	8.35	UNKNOWN		45.0
7W5C	-25.0	-13.0	14.10	10.40	UNKNOWN		65.0
7W5K	-25.0	-13.0	13.80	10.18	UNKNOWN		65.0
7W5O	-12.5	9.5	17.07	12.59	UNKNOWN		70.0
7W5B	0.0	32.0	14.53	10.72	UNKNOWN		70.0
7W5A	25.0	77.0	18.40	13.57	UNKNOWN		100.0
7W5P	100.0	212.0	19.92	14.69	UNKNOWN		100.0
7W5Q	200.0	392.0	20.13	14.85	UNKNOWN		100.0
7W5R	200.0	392.0	19.01	14.02	UNKNOWN		100.0

NUMBER OF SPECIMENS: 17

SOURCE: 72W_T5 ANALYSIS SET

Y VARIABLE: ENERGY

MODEL PARAMETERS

LOWER SHELF ENERGY [HELD FIXED]: 0.1 (J), 0.1 (FT-LB)

MID-TRANSITION TEMPERATURE: -63.6 (DEG C), -82.5 (DEG F)

TRANSITION ZONE WIDTH: 121.1 (C DEG), 218.0 (F DEG)

UPPER SHELF ENERGY: 19.1 (J), 14.1 (FT-LB)

UPPER SHELF ENERGY: 19.1 (J), 14.1 (FT-LB)

NOTE: HSSI WELD 72W, TYPE 5

MODEL SET NAME: 3

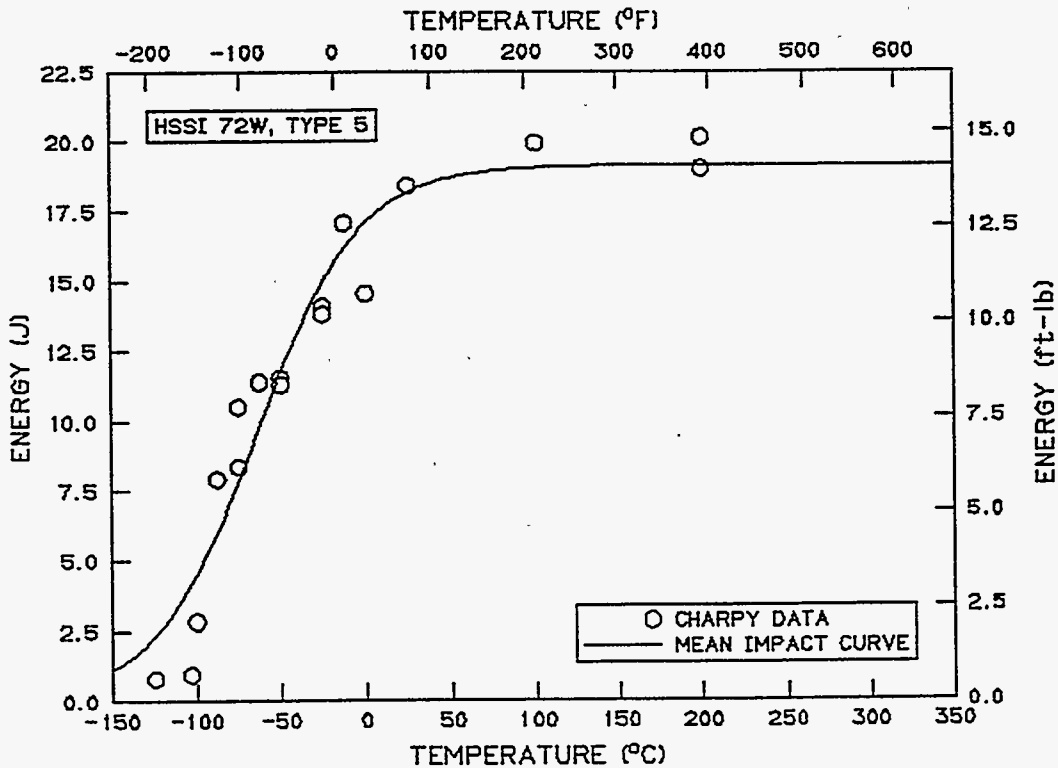

SOURCE: 72W_T5 ANALYSIS SET

Y VARIABLE: SHEAR

MODEL PARAMETERS

LOWER SHELF SHEAR [HELD FIXED]: 0 (PERCENT)

MID-TRANSITION TEMPERATURE:-36.5 (DEG C),-33.6 (DEG F)

TRANSITION ZONE WIDTH: 86.7 (C DEG),156.0 (F DEG)

UPPER SHELF SHEAR [HELD FIXED]: 100 (PERCENT)

UPPER SHELF SHEAR: 100 (PERCENT)

TEMPERATURE [50 (PERCENT),50 (PERCENT) SHEAR]:-36.5 (DEG C),-33.6 (DEG F)

NOTE: HSSI WELD 72W, TYPE 5

MODEL SET NAME: 4

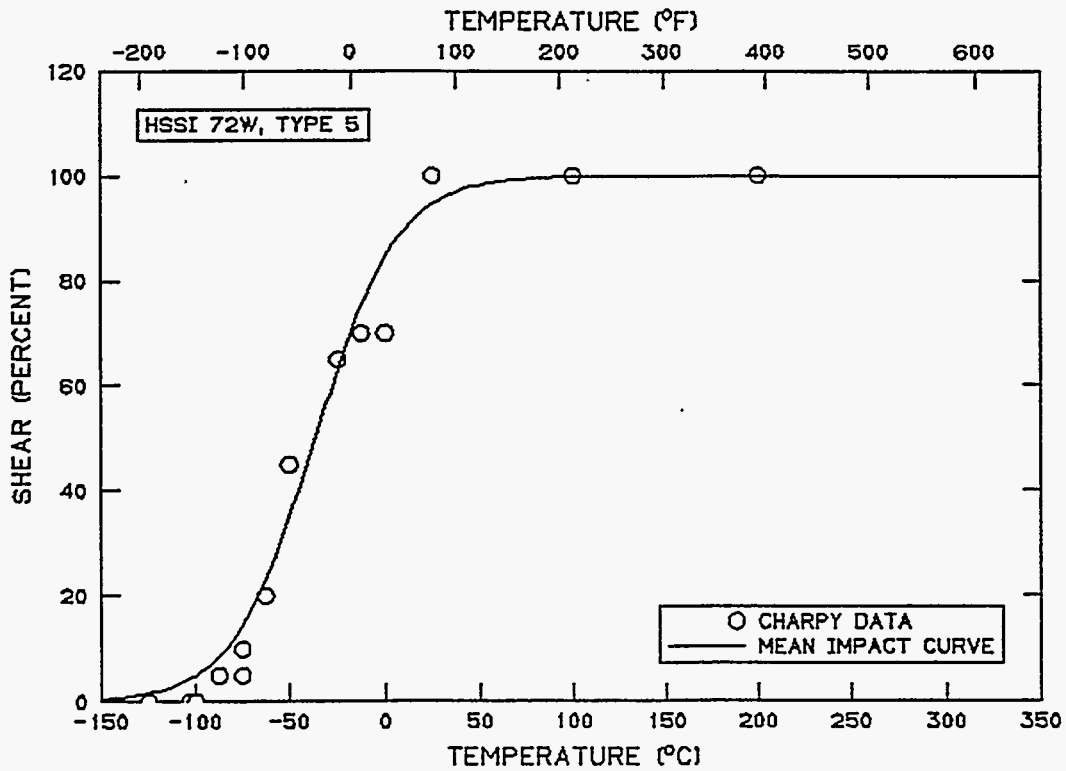

BIBLIOGRAPHIC DATA SHEET

(See instructions on the reverse)

1. REPORT NUMBER
(Assigned by NRC. Add Vol., Supp., Rev.,
and Addendum Numbers, if any.)

NUREG/CR-6379
ORNL-6888

2. TITLE AND SUBTITLE

An Improved Correlation Procedure for Subsize and Full-Size Charpy Impact Specimen Data

3. DATE REPORT PUBLISHED

MONTH | YEAR
March | **1997**

4. FIN OR GRANT NUMBER

L1098

5. AUTHOR(S)

M. A. Sokolov and D. J. Alexander

6. TYPE OF REPORT

Technical

7. PERIOD COVERED *(Inclusive Dates)*

8. PERFORMING ORGANIZATION - NAME AND ADDRESS *(If NRC, provide Division, Office or Region, U.S. Nuclear Regulatory Commission, and mailing address; if contractor, provide name and mailing address.)*

Oak Ridge National Laboratory
Oak Ridge, TN 37831-6285

9. SPONSORING ORGANIZATION - NAME AND ADDRESS *(If NRC, type "Same as above"; if contractor, provide NRC Division, Office or Region, U.S. Nuclear Regulatory Commission, and mailing address.)*

Division of Engineering Technology
Office of Nuclear Regulatory Research
U.S. Nuclear Regulatory Commission
Washington, DC 20555-0001

10. SUPPLEMENTARY NOTES

M. G. Vassilaros, NRC Project Manager

11. ABSTRACT *(200 words or less)*

To examine the potential for using subsize Charpy specimens to evaluate the material properties of vessel materials for life extension, a study was conducted on the behavior of subsize impact specimens of five different geometries. Effects of notch depth, angle, and radius, as well as overall specimen dimensions were determined. Correlations of the transition temperature determined by the different subsize specimens as compared to full-size specimens were evaluated. A new procedure for transforming data from subsize specimens was developed.

12. KEY WORDS/DESCRIPTORS *(List words or phrases that will assist researchers in locating the report.)*

impact testing
subsize specimens
pressure vessels
geometry effects
transition temperature

13. AVAILABILITY STATEMENT

Unclassified

14. SECURITY CLASSIFICATION

(This Page)

Unclassified

(This Report)

Unclassified

15. NUMBER OF PAGES

16. PRICE