

CONF-970503--37

SLAC-PUB-7505  
May, 1997

## RF BREAKDOWN STUDIES IN X-BAND KLYSTRON CAVITIES\*

X. Xu, R. S. Callin, W. R. Fowkes, A. Menegat, G. P. Scheitrum, D. H. Whittum

Stanford Linear Accelerator Center  
Stanford University, Stanford, CA 94309

### ABSTRACT

RECEIVED

JUN 20 1997

OSTI

RF breakdown studies are presently being carried out at SLAC with klystron cavities in a traveling wave resonator (TWR). Different kinds of fabrication methods and several kinds of semiconducting and insulating coatings have been applied to X-Band  $TM_{010}$  cavities. RF breakdown thresholds up to 250 MV/m have been obtained. Dark current levels were found to be depressed in TiN-coated and single-point diamond turned cavities. A new  $TM_{020}$  cavity with demountable electrodes has been designed and will be used to test a variety of materials, coatings, and processes. Recent tests of klystron output windows at 119 MW are also presented in this paper.

MASTER

H H  
DISTRIBUTION OF THIS DOCUMENT IS UNLIMITED

*Presented at the 1997 Particle Accelerator Conference (PAC97),  
Vancouver, B.C., Canada, May 12-16, 1997*

---

\*This work is supported by the Department of Defense, contract F49620-95-1-0253, and the Department of Energy, contract DE-AC03-76SF00515.

## DISCLAIMER

This report was prepared as an account of work sponsored by an agency of the United States Government. Neither the United States Government nor any agency thereof, nor any of their employees, make any warranty, express or implied, or assumes any legal liability or responsibility for the accuracy, completeness, or usefulness of any information, apparatus, product, or process disclosed, or represents that its use would not infringe privately owned rights. Reference herein to any specific commercial product, process, or service by trade name, trademark, manufacturer, or otherwise does not necessarily constitute or imply its endorsement, recommendation, or favoring by the United States Government or any agency thereof. The views and opinions of authors expressed herein do not necessarily state or reflect those of the United States Government or any agency thereof.

### **DISCLAIMER**

**Portions of this document may be illegible in electronic image products. Images are produced from the best available original document.**

## 1. INTRODUCTION

RF breakdown is a critical issue in the development of high power microwave sources and next generation linear accelerators since it limits the output power of the microwave sources and the accelerating gradient of the linacs. The motivation of the RF breakdown study is to determine the maximum electrical field gradient that can be used safely in klystrons and next generation accelerator structures, find better materials and surface treatments that can raise the field limit, reduce the dark current, and to contribute to the basic understanding of the RF breakdown phenomenon.

The development of high power microwave sources to the performance levels required by future linear colliders has been limited by RF breakdown in the output resonator. Raising the breakdown threshold could increase the peak output power capability of the X-band klystrons for the next linear collider. Lowering the field emission for a given electric field would improve klystron and linac performance. Furthermore, the next generation of linear colliders will have to reach the TeV energy range, and the accelerating gradient will be one of the crucial parameters affecting their design, construction and cost. For a specified total energy, the gradient sets the accelerator length, and once the RF structure, frequency and pulse repetition rate are selected, it also determines the peak and average power consumption. Recent overall parameter studies for a 1 TeV linear collider indicate that accelerating gradients approaching 100 MV/m are desirable.

Considerable research has been done on RF breakdown phenomenon in vacuum structures[1,2,3]. However, no coherent picture of the mechanism of the RF breakdown has been obtained due to the large number of variables and the range of parameters involved. Consequently, more systematic work is needed to gain further understanding into the underlying physics, to determine if the required output power is obtainable in the X-band klystron and the acceleration gradient is achievable in long and complicated structures. We also wish to verify that the dark currents which can absorb RF energy, cause parasitic wakefields and spurious x-rays along the RF structures are tolerable.

## 2. EXPERIMENTAL SETUP

The experiments are carried out by putting a field enhancing cavity into a traveling wave resonant ring (TWR) as shown in Fig.1. The power source is an X-band klystron (XC-2) with a frequency of 11.426 GHz, peak output power of 30 MW and pulse width of 1.5  $\mu$ s. The power multiplication in the resonant ring is obtained by wrapping a WR-90 waveguide around into a ring configuration and recombining it with a 10 dB bridge coupler. A precision variable phase shifter and 6-element tuner, both designed to withstand extremely high RF electric fields, are put into the ring in order to achieve the resonant condition and also to tune out the small residual reflections. All RF conducting surfaces are OFC copper or

copper plated stainless steel. No organic vacuum seal is used. A stored RF traveling wave that is 10 times greater in power than the input can be obtained [4].

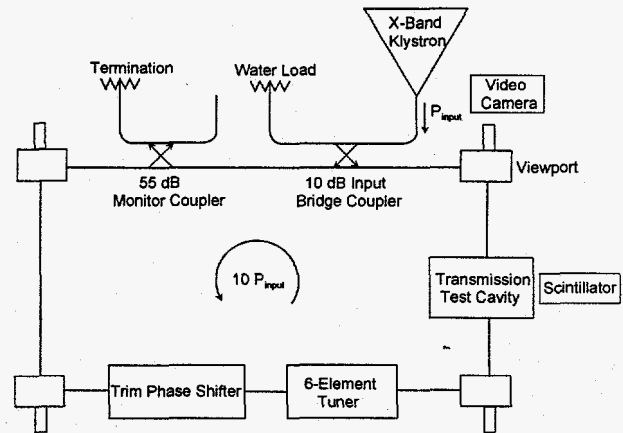

Fig. 1. Experimental setup

The parameters of the TWR are shown in Table 1. The test cavity is a symmetrical transmission type with reentrant noses, and is coupled to two waveguides through a pair of inductive irises (Fig.2). The cavity is designed by SUPERFISH and is capable of producing an electric field surface gradient as high as 600 MV/m. The maximum surface electrical field gradient is given by

$$E_s = 42.5 \sqrt{P_{Ring}} \quad (1)$$

where  $E_s$  is in MV/m and  $P_{Ring}$  is in MW.

Table 1. TWR Parameters

Highest TWR Power	300 MW, 800 nsec, 60pps
Maximum Available Source Power	30 MW
Resonant Loop Length	340 cm
Number of Guide Wavelengths	106 @ 11.424 GHz
Input Bridge Coupler Ratio	10.1 dB
Separation Between Resonance	71.5 MHz
High Power Gain	10.6 dB
One-Way Loss in Loop	0.354 dB
Variable Phase Shifter Range	$\pm 30^\circ$ ( $\pm 6$ MHz)
6-Element Tuner Range	$\leq 0.10$ @ any frequency
Loaded Q	5500
RF Voltage Time Constant	153 nsec
Input Coupling Coefficient	1.23

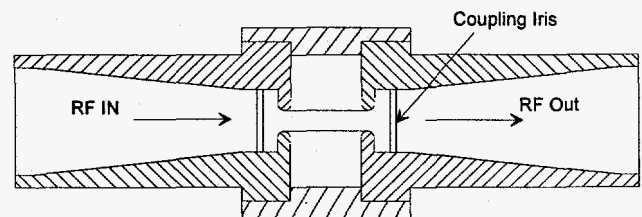

Fig. 2.  $TM_{010}$  RF breakdown test cavity geometry with field enhancing noses.

### 3. RESULTS OF TM<sub>010</sub> CAVITY TEST

Five TM<sub>010</sub> cavities have been tested in the traveling wave resonant ring, each with a different combination of surface polish, coating. As shown in Fig. 1, a scintillator and photomultiplier were mounted beside the test cavity to measure the x-ray level from the cavity to characterize the breakdown process. A video camera was used to monitor sparks in the test cavity during RF processing. The tests were performed starting from low RF power for about 80 hours for each cavity. The onset of breakdown was pushed up to 250 MV/m in a 12 μinch surface finish cavity with TiN(100Å) coating and a single-point diamond turned cavity with less than 1 μinch surface finish, as shown in Table 2. Although the two uncoated cavities were fabricated by different methods with different surface finish, the breakdown threshold of these two cavities was the same, 210 MV/m. A 1 μinch surface finish with TiN(600Å) coated cavity was also processed to 210 MV/m but the breakdown threshold of the cavity was not reached due to a vacuum leak from the top of this cavity. The amplitude of field emission currents from the tested cavity surface as a function of peak surface electrical field is shown in Fig. 3 taking the observed scintillator voltage  $V_{scint}$  as an indicator of the field emission current. The lowest dark current was obtained with the single-point diamond turned cavity. The TiN coating was very helpful for depressing the field emission.

Table 2. Test results of TM<sub>010</sub> cavities

Fabrication Method	Surface Finish (μinch)	Coating	RF Breakdown Threshold
Mechanical Polish	12	None	210 (MV/m)
Mechanical Polish	12	TiN(100Å)	250 (MV/m)
Diamond Polish	1	None	210 (MV/m)
Diamond Polish	1	TiN(600Å)	220 (MV/m)
Single-Point Diamond Turning	<1	None	250 (MV/m)

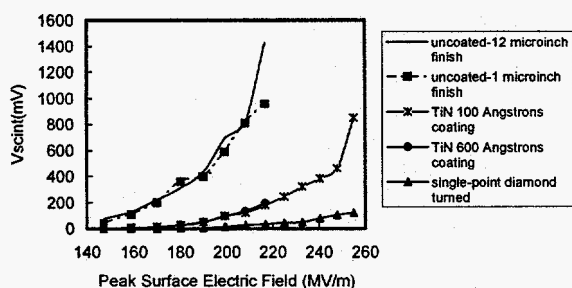

Fig. 3. Scintillator voltage as a function of peak electric field in the test cavities.

### 4. TM<sub>020</sub> CAVITY DESIGN

It was quite difficult to make various coatings on the noses of the TM<sub>010</sub> cavities because of the very small gap between the nose tips. The TM<sub>010</sub> cavities must be cut apart in order to make surface analysis. Furthermore, the irises are very close to the reentrant noses of the TM<sub>010</sub> cavities and perturb the electrical field distribution in the cavities. This may cause the local surface electrical field gradient in the cavity to be much higher than that calculated from Eq. (1).

A TM<sub>020</sub> cavity with replaceable cavity noses has been designed, and a sketch of the cavity is shown in Fig. 4. The irises are far from the nose tips. The high field surfaces on the two cavity noses can be coated more easily, and some coating techniques such as sputtering, ion bombardment can be used. This demountable device not only simplifies the surface analysis of the nose surfaces before and after the high power RF test, but also makes it possible to evaluate surface damage nondestructively.

A large number of different materials, coatings and surface finishes will be performed on the TM<sub>020</sub> cavity noses. The materials that will be tested are Glidcop, copper-zirconium, HIP (hot isostatic pressed) copper, single crystal copper, tungsten, stainless steel and Monel. There is some evidence that surface roughness, surface contamination and surface treatment are directly related to the RF breakdown. It is also shown in our experiments that better surface finish can decrease the field emission current. Consequently, wire electrodischarge machining, precision diamond grinding, single-point diamond turning and elastic emission machining together with surface treatments such as electropolish and high pressure water rinse will be applied to the cavity noses to get a very clean surface with a surface finish up to 2 nm.

In order to get real-time x-ray image from the cavity noses using a CCD camera, a tungsten pinhole (0.005") with a beryllium window is designed in the cavity. A germanium gamma-ray detector will be used to measure the spectrum of x-rays, and an optical port in the cavity back wall will be used to measure infrared output from the field emission sites on the electrode surfaces.

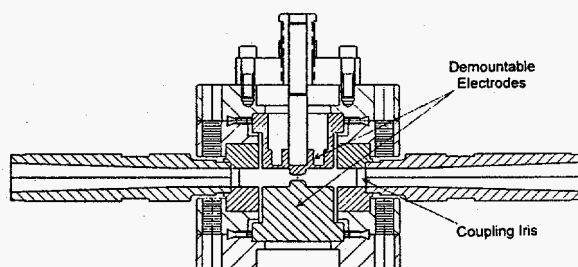

Fig. 4. TM<sub>020</sub> RF breakdown test cavity assembly

## 5. X-BAND KLYSTRON OUTPUT WINDOW TEST

Another very important component in a high power klystron is its output window. Because very high RF powers must be transmitted through the output window, there are several different types of breakdown phenomena of concern, e.g. multipactor and puncture. Many studies and tests have been performed to investigate the breakdown mechanism and to find a window design with a high probability of long life [5]. The X-band ceramic output window is shown in Fig.5. The window is 0.086" thick, and the window material is 99.7% alumina (NTK-HA-997) with TiN(10Å) coating in order to avoid the buildup of surface charge and to reduce secondary electron emission.

The window was tested in the traveling wave resonant ring at a frequency of 11.425 GHz with a pulse width of 1.5  $\mu$ s and pulse repetition rate of 60 pps. The RF power was coupled in and out of the window through two TE<sub>10</sub>/TE<sub>01</sub> flower petal mode transducers [6]. The window was processed carefully for more than 150 hours, the highest stable operating power obtained to date was 119 MW. X-ray levels from the window were very low implying that there was no breakdown at the window. This result was limited by the performance of our Test Stand not by the window itself. The window has been taken off and checked, no obvious damage has been found.

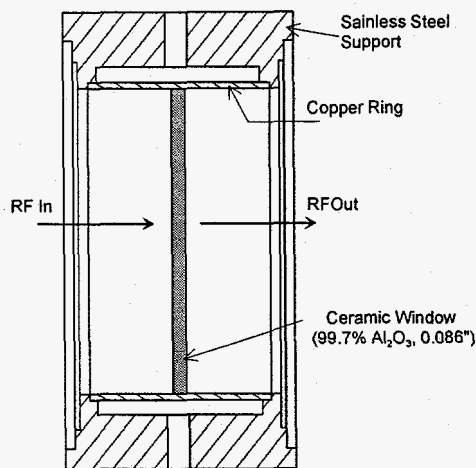

Fig. 5. Output ceramic window.

The window was tested in the traveling wave resonant ring at a frequency of 11.425 GHz with a pulse width of 1.5  $\mu$ s and pulse repetition rate of 60 pps. The RF power was coupled in and out of the window through two TE<sub>10</sub>/TE<sub>01</sub> flower petal mode transducers [6]. The window was processed carefully for more than 150 hours, the highest stable operating power obtained to date was 119 MW. X-ray levels from the window were very low implying that there was no breakdown at the window. This result was limited by the performance of our

Test Stand not by the window itself. The window has been taken off and checked, no obvious damage has been found.

## 6. SUMMARY

Different kinds of fabrication methods and several kinds of semiconducting and insulating coatings have been applied to the X-band TM<sub>010</sub> cavities. RF breakdown thresholds up to 250 MV/m (pulse width: 1.5  $\mu$ s, pulse repetition: 60pps) have been obtained. Dark current levels from the TiN-coated and single-point diamond turned cavities are far less than those from traditionally machined cavities. A new TM<sub>020</sub> cavity with demountable electrodes will be used to test a variety of materials, coatings and processes. The real-time x-rays output from the electrodes will be detected to get more information about the RF breakdown phenomenon. The spectrum of x-rays will be measured to calibrate the surface electrical field gradient in the TM<sub>020</sub> cavity, and the temperature of the electrodes will be measured to clarify the relationship between the field emission and the surface temperature. The peak power of 119 MW (pulse width: 1.5  $\mu$ s, pulse repetition: 60 pps) through the X-band klystron output window has been obtained, and the tests suggest that higher output power is possible.

## 7. ACKNOWLEDGMENT

The authors would like to thank R. Siemann and J. W Wang for their helpful discussions.

## 8. REFERENCES

- [1] G. A. Loew, J. W. Wang, 'RF Breakdown Studies in Room Temperature Electron Linac Structures', SLAC-PUB-4647, May 1988.
- [2] E. Tanabe, J. W. Wang, G. A. Loew, 'Voltage Breakdown at X-Band and C-Band Frequencies', Proc. 1986 Linear Accelerator Conference.
- [3] W. Peter, 'Vacuum Breakdown and Surface Coating of RF Cavities', J. Appl. Phys. **56**, 1546 (1984).
- [4] W. R. Fowkes, R. S. Callin, M. Studzinski, 'Component Development for X-Band Above 100 MW', SLAC-PUB-5544, May 1991.
- [5] A. E. Vliks, et al., 'Breakdown Phenomena in High Power Klystrons', SLAC-PUB-4546, March 1988.
- [6] S. Tantawi, K. Ko and N. Kroll, 'Numerical Design and Analysis of a Compact TE<sub>10</sub> to TE<sub>01</sub> Mode Transducer', SLAC-PUB-6085, April 1993.