

A Preamp-Amplifier-Discriminator Module Developed For The CTEN Waste Assay System

G.J. Arnone
Los Alamos National Laboratory
Los Alamos, New Mexico 87545

RECEIVED
JAN 21 1997
OSTI

ABSTRACT

We describe a preamp-amplifier-discriminator module that was developed for the CTEN (combined thermal-epithermal neutron) waste assay system. The CTEN system uses a pulsed-neutron interrogation technique to quantify the amount of low-level transuranic waste contained in a waste drum. Epithermal neutrons are used to determine the effects of self-shielding in lumps of fissile material. In order to enhance the measurement of epithermal neutrons, we were required to develop new front-end electronics. We describe the module developed and the techniques used to improve performance.

Introduction

MASTER

The CTEN system is used to measure low-level, transuranic waste stored in 55 gallon drums. The system incorporates the differential die away technique[1] along with information obtained from epithermal neutrons to quantify the amount of low-level transuranic waste. In the active mode a sample drum is interrogated with 14 Mev neutrons and several types of He3 and He4 detectors are used to obtain information about the contents of the drum. Epithermal neutrons are present immediately following the injection of 14 Mev interrogation neutrons and are detected with He4 detectors. The signal derived from these detectors are used to determine the effects of self-shielding in lumps of fissile material. In order to obtain accurate epithermal neutron information, the front end electronics is required to recover immediately after an interrogation event. We designed a preamplifier/amplifier circuit that employs current-feedback operational amplifiers and packaged it into a small, easy to use module. This design effort culminated

DISTRIBUTION OF THIS DOCUMENT IS UNLIMITED

DISCLAIMER

Portions of this document may be illegible in electronic image products. Images are produced from the best available original document.

in a 4-channel module referred to as the PADEM (preamplifier-amplifier-discriminator-ECL(emitter-coupled logic) driver module). The PADEM is composed of 4 independent signal channels each consisting of a charge preamplifier, a shaping amplifier, a low-level discriminator(LLD), an ECL driver section and gating circuitry. The PADEM allows all key parameters to be user-selectable. The selectable parameters are: charge-preamplifier-integration time, differentiator time constant, first and second integrator time constants, LLD threshold setting, and gain. The ECL signals are provided on a standard ECL cable, thereby allowing up to 4 PADEMs or 16 channels per cable. A diagnostic connector provides each channels' preamplifier output, shaping amplifier output, LLD output, and gate output. By using the gate output with a standard pulse-height analyzer, one can accurately set the LLD threshold. The use of high density, state-of-the-art, components led to a design that is fast, compact(app. 46cu.cm.), low power and low cost.

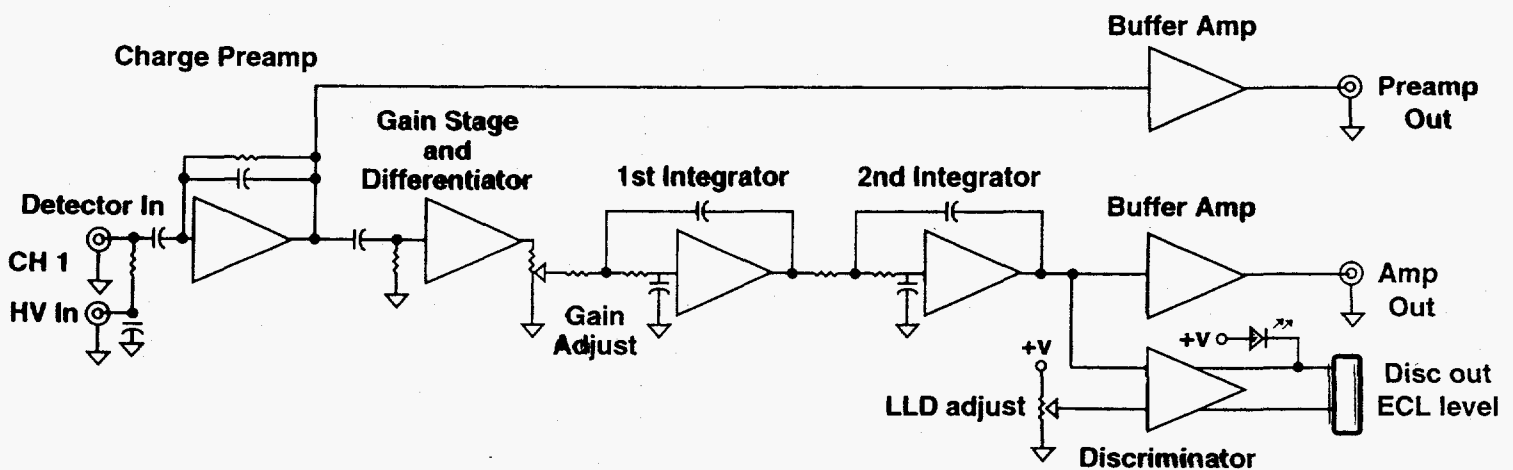

Fig. 1 Single Channel Block Diagram

PADEM Circuit Description

The PADEM contains 4 identical signal channels, Fig. 1 is a block diagram of one channel. A He3 or He4 detector signal is fed directly into a charge sensitive pre-amp. This pre-amp is designed using a commercially available FET input op amp. The integration time can be set from .5usec to 4.7usec. It has a sensitivity of 200mv/pC for the .5 usec. integration time. The output of the integrator is fed through a differentiator, whose time constant can be selected, into a gain stage. This stage can be set to a gain of 2,

14 or 40. The output of the gain stage is fed into the 1st and 2nd integrators. These stages have selected time constants. The output of the integrator is feed to a LLD(low-level discriminator) whose output is converted to ECL. There are buffer signals available for system setup they are, the pre-amp out, the amp out and the gate out. The gate out used in conjunction with the amp out can be feed to multi-channel analyzer to provide an accurate setting of the LLD theshold.

Status

Twelve PADEMs are used on the CTEN system to provide 48 signal processing channels for both He3 and He4 neutron detectors. PADEMs are currently being incorporated into other systems under development. The PADEM is also being evaluated by a commercial company for technology transfer.

Acknowledgments

I would like to gratefully acknowledge the valuable conceptual design input from Ken Coop and Charles Hollas both from LANL.