

**Paper Number:**

DOE/METC/C-97/7254

**Title:**

PFBC and IGCC Power Generation Technologies -- Status and Opportunities

**Authors:**

R.D. Brdar (METC)

R.B. Reuther (METC)

**Conference:**

Advanced Coal-Fired Power Systems '96 Review Meeting

**Conference Location:**

Morgantown, West Virginia

**Conference Dates:**

July 16-18, 1996

## **Disclaimer**

This report was prepared as an account of work sponsored by an agency of the United States Government. Neither the United States Government nor any agency thereof, nor any of their employees, makes any warranty, express or implied, or assumes any legal liability or responsibility for the accuracy, completeness, or usefulness of any information, apparatus, product, or process disclosed, or represents that its use would not infringe privately owned rights. Reference herein to any specific commercial product, process, or service by trade name, trademark, manufacturer, or otherwise does not necessarily constitute or imply its endorsement, recommendation, or favoring by the United States Government or any agency thereof. The views and opinions of authors expressed herein do not necessarily state or reflect those of the United States Government or any agency thereof.

# **Advanced Coal-Fired** **Power Systems '96**

***Dan Brdar***     ***IGCC Product Manager***  
***Bob Reuther***   ***PFBC Product Manager***

***Morgantown Energy Technology Center***  
***July 16, 1996***

# Overview

- *Product Lines*
- *Product Goals*
- *Product Development Strategy*
- *This Year's Successes*
- *Barrier Issues*
- *Key Plans For Next Year*
- *Technical Status*
- *Market Opportunities*



# *Vision*

*Worldwide, Most New And Repowered Electric  
Generating Capability Will Use IGCC And PFBC  
Technologies Due To Their Superior Environmental  
Performance, Cost And Efficiency*

# *Product Lines*

*"The Future of Coal Based Power Generation"*



***IGCC***



***PFBC***

# Integration Gasification Combined Cycle (IGCC)

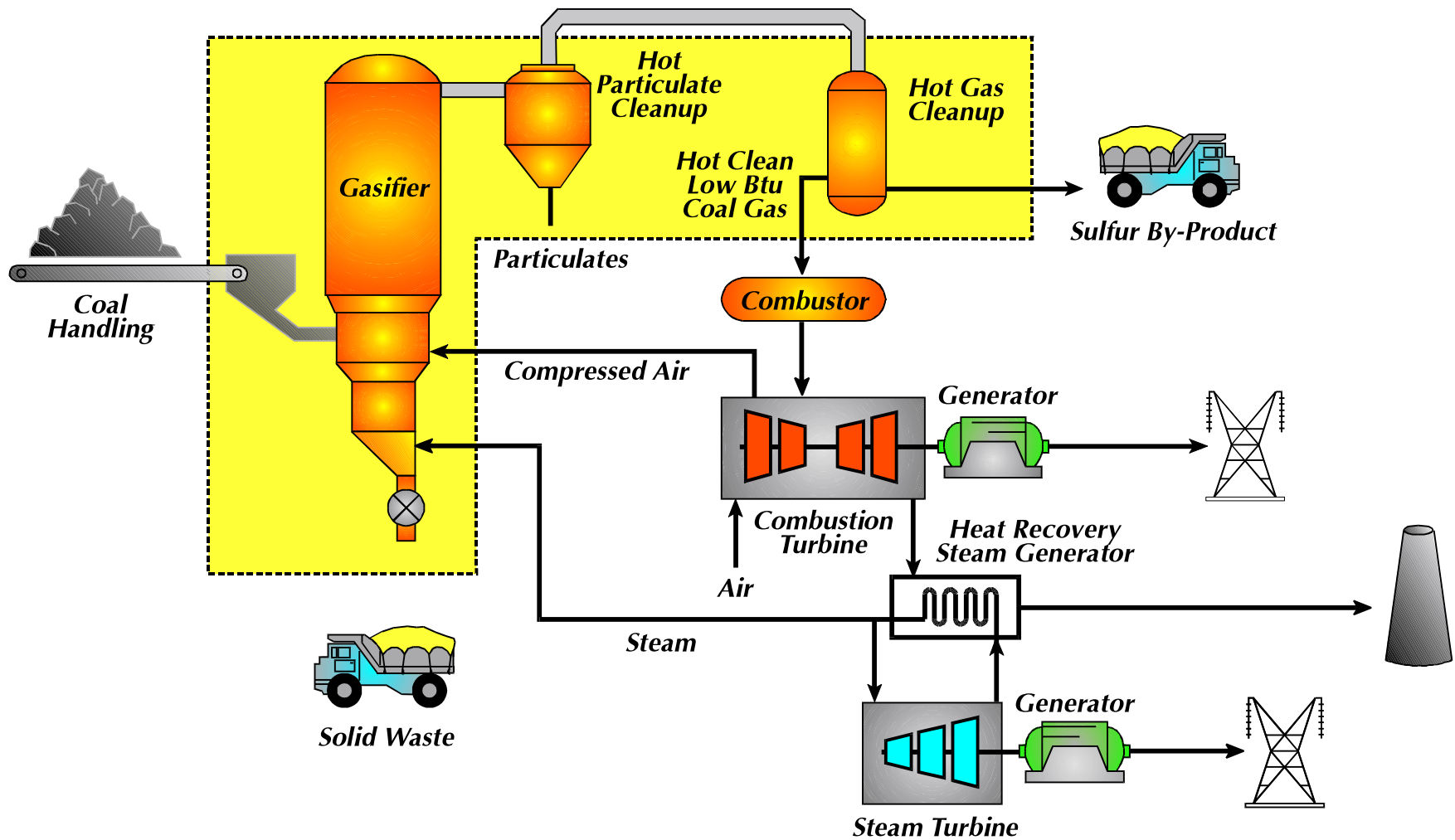

# Pressurized Fluidized Bed Combustion (PFBC)

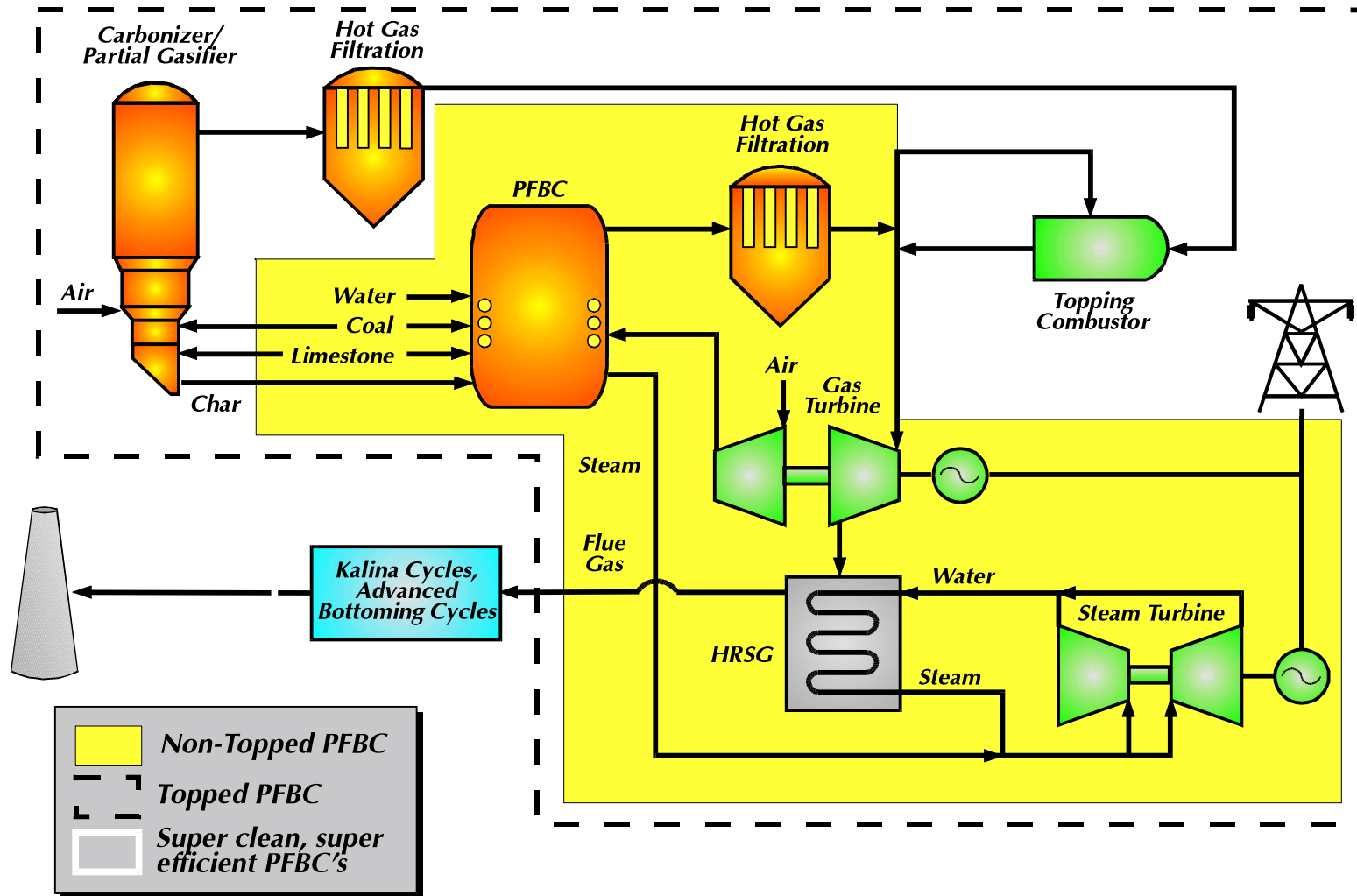



# Goals

- ***Coal Based Power Systems***
  - ***Environmental Performance***
  - ***Efficiency***
  - ***Cost***



# IGCC Goals

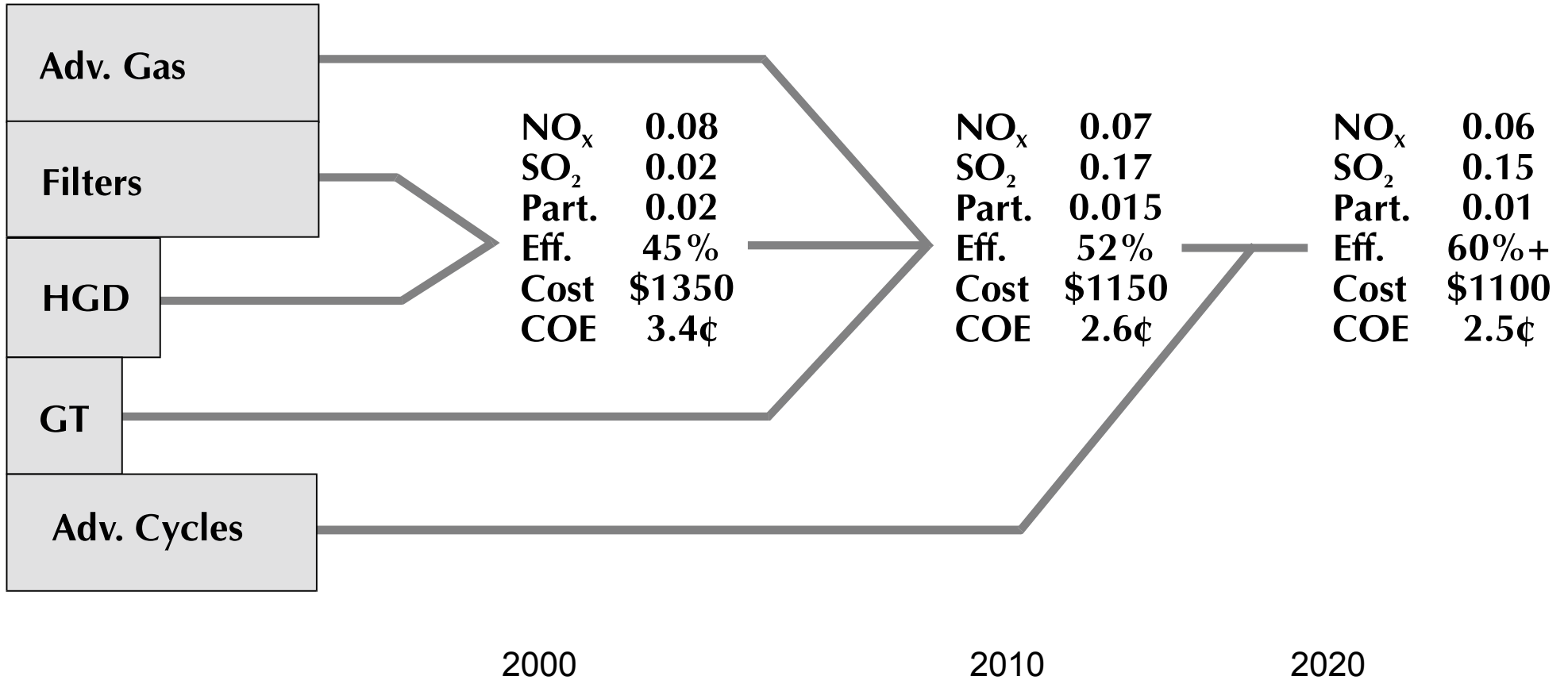

# PFBC Goals

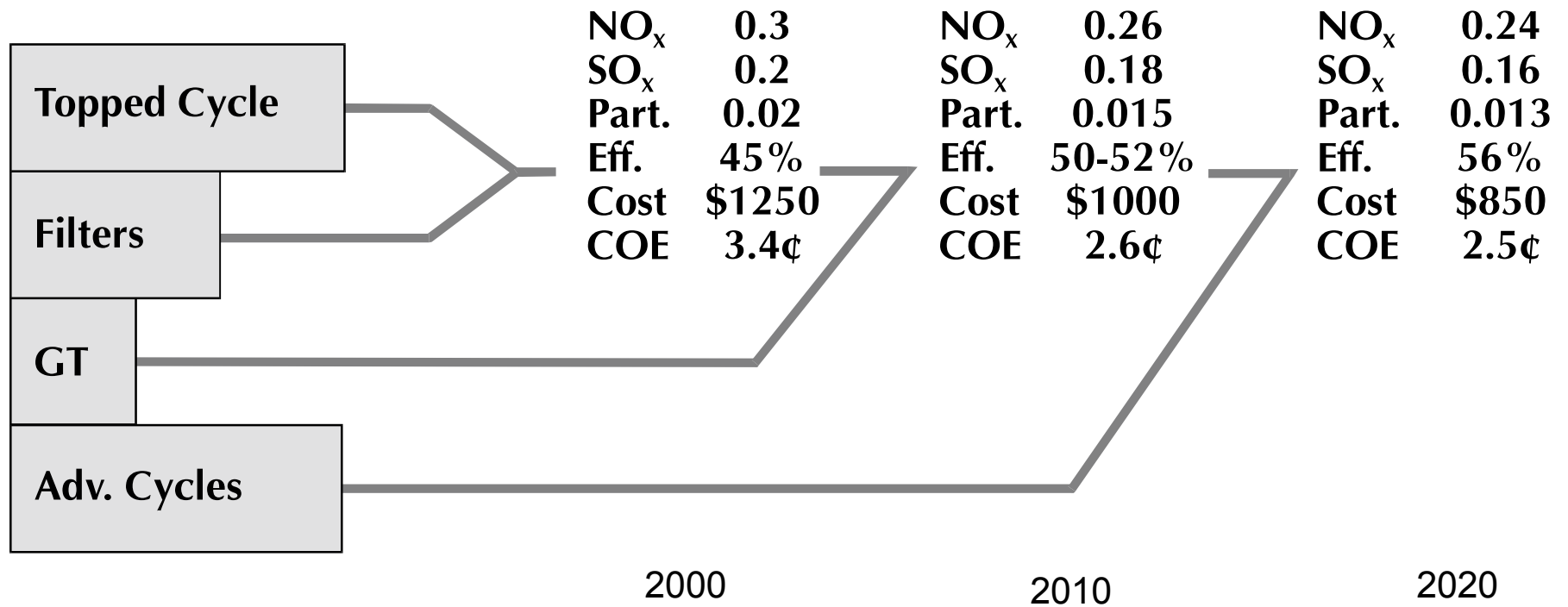

# Product Development Cycle

*METC  
In-House  
R&D*

**Concept  
Development**

**Subsystem / Component  
Advances**

**Cooperative Research and Development**

*Contractor  
R&D*

**Systems  
Studies**

**Bench  
Scale  
Tests**

**PDU / Pilot  
Scale  
Tests**

*Clean Coal  
Technology (CCT)  
Programs*

**Demonstration Plants**

*Design/Operational  
Support*

*Product Improvement*

**Commercial Plants**

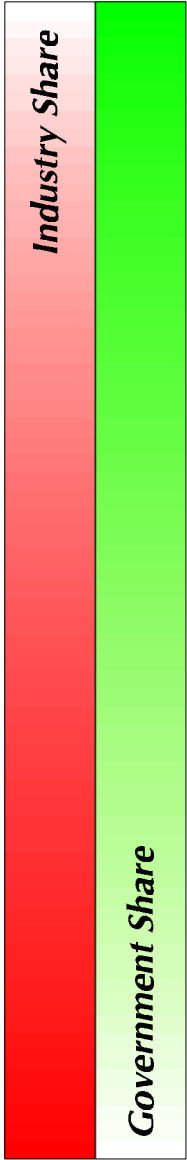

# Product Development Cycle

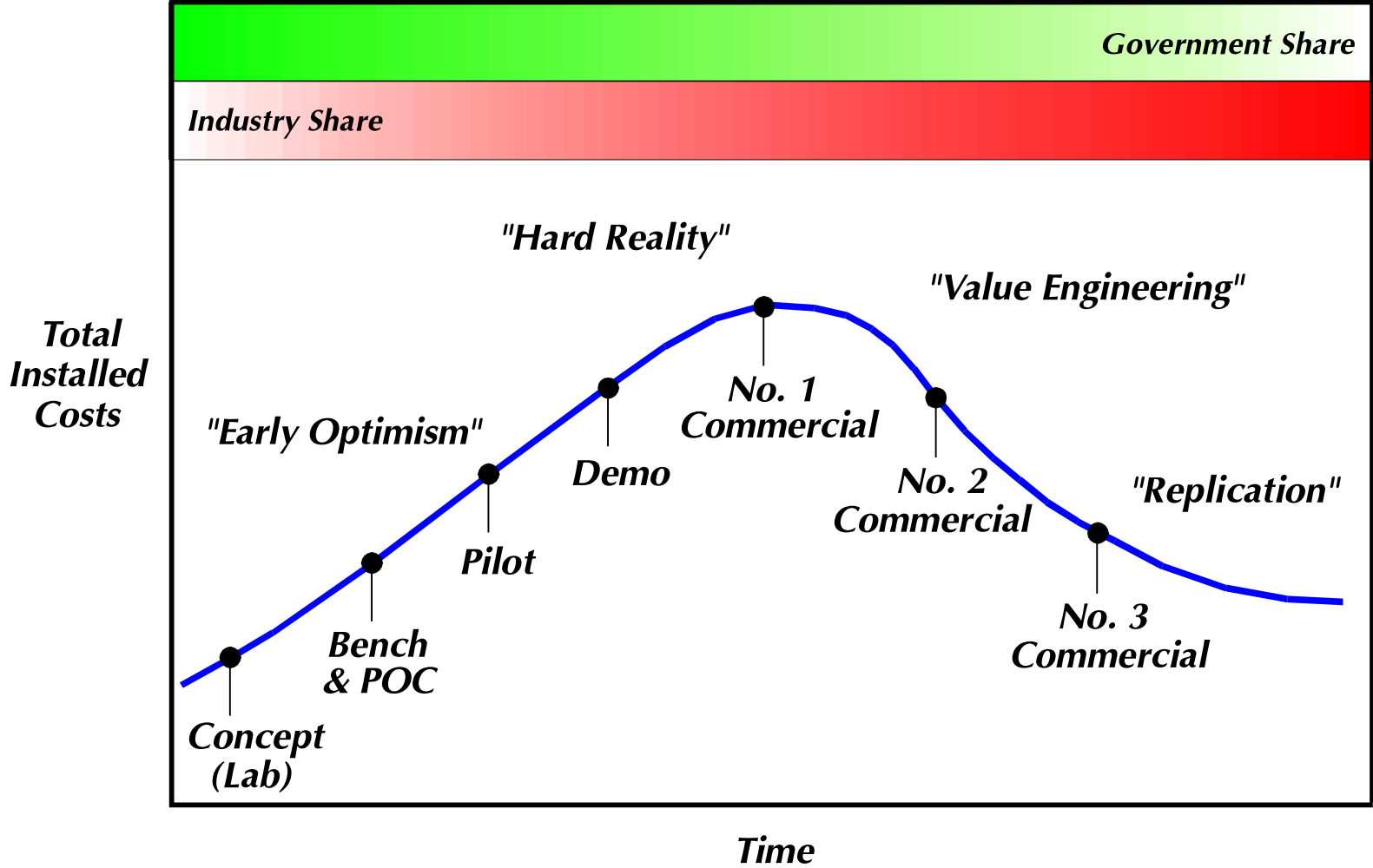

# ***Technical Status***

- ***Key R&D Activities***
- ***Product Development***
- ***Demos and R&D***

# ***Key R&D Activities***

---

## ***Sorbents***

***ICCI  
GEESI  
METC  
RTI***

## ***Filters***

***EERC  
MGCR  
KARHULA  
METC***

## ***Air Toxics***

***LGTI  
AMES***

# IGCC Projects, Major R&D, Support

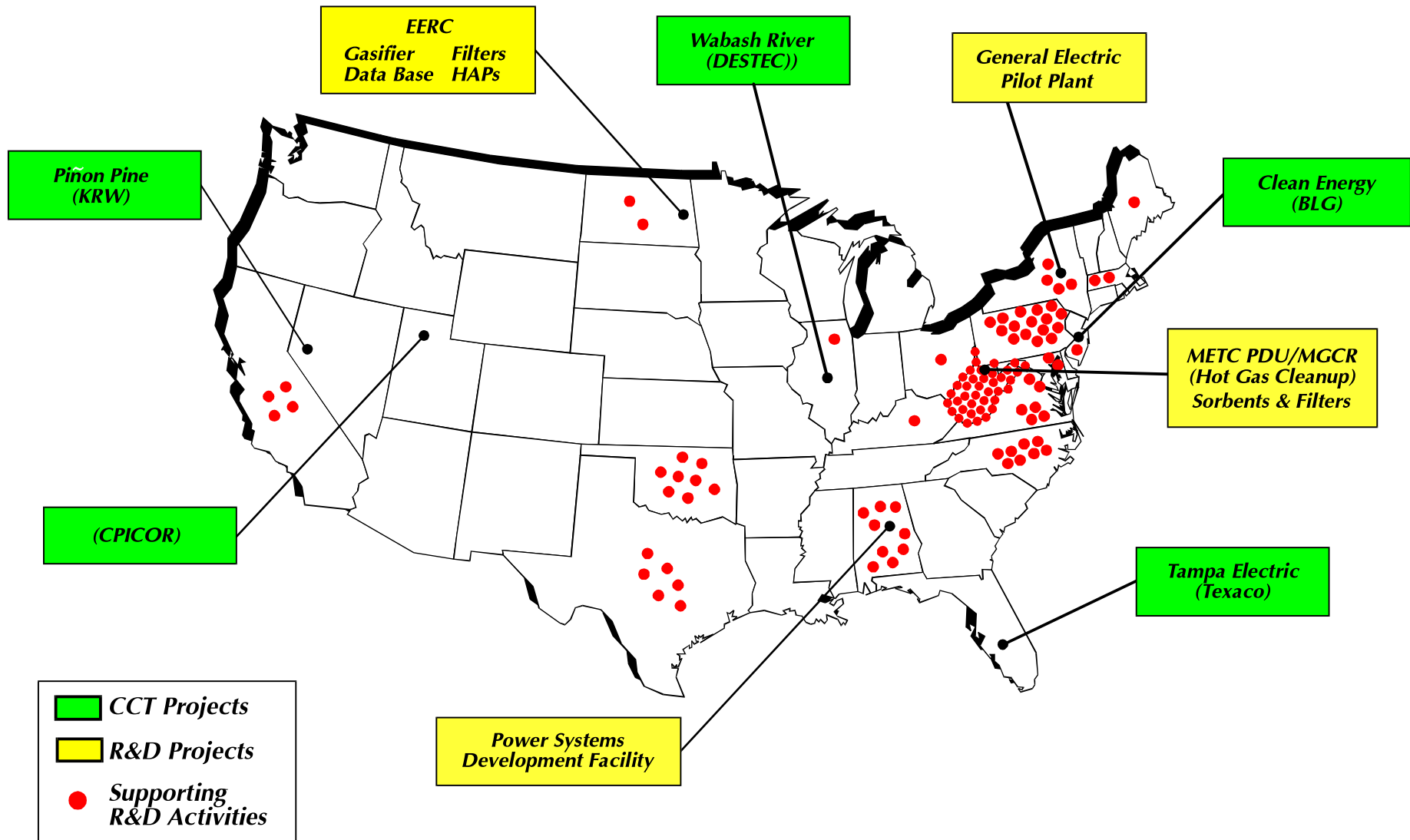



# PFBC Projects, Major R&D, Support

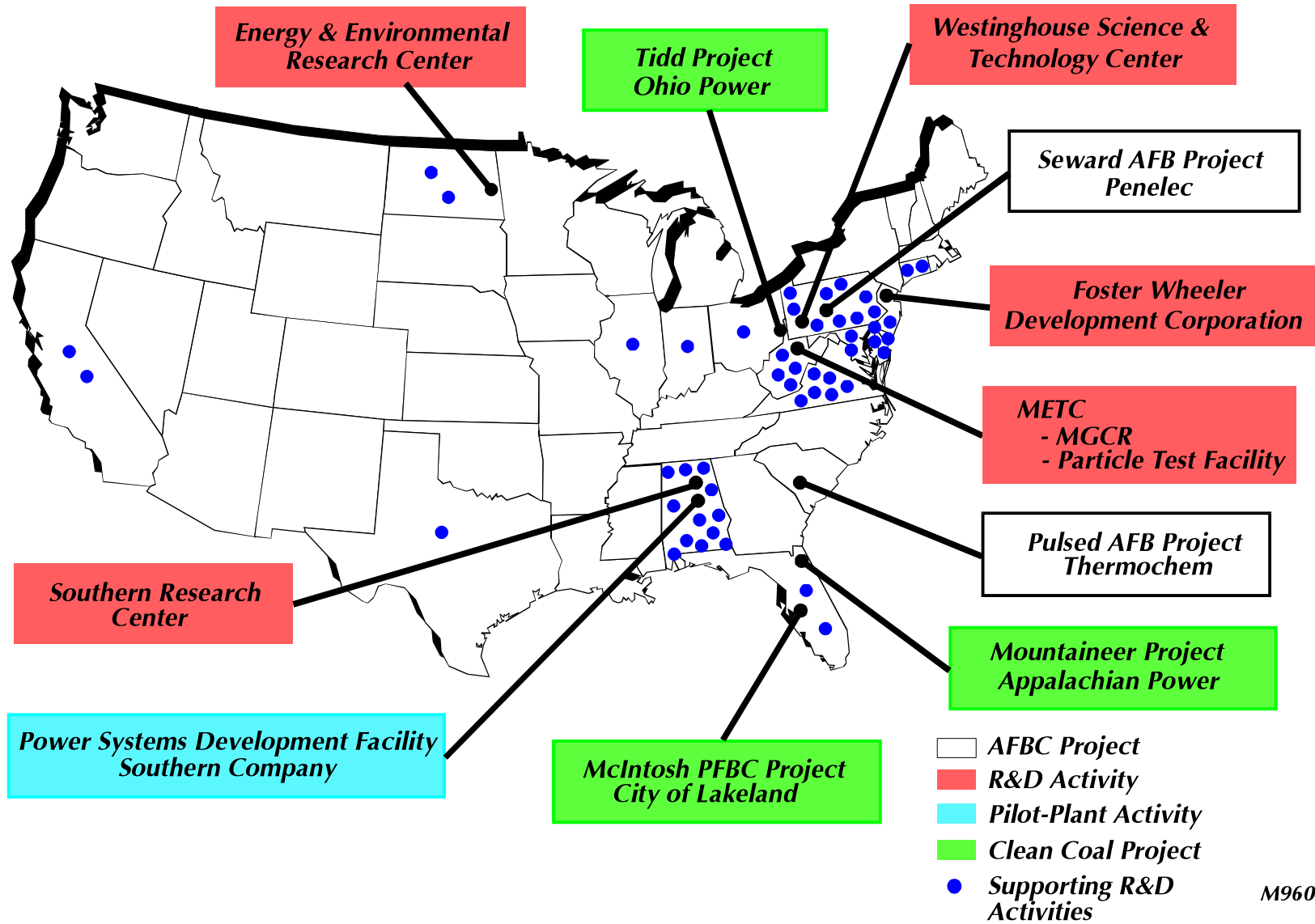

# Power Systems Development Facility Consists of Two Separate Reactor Systems

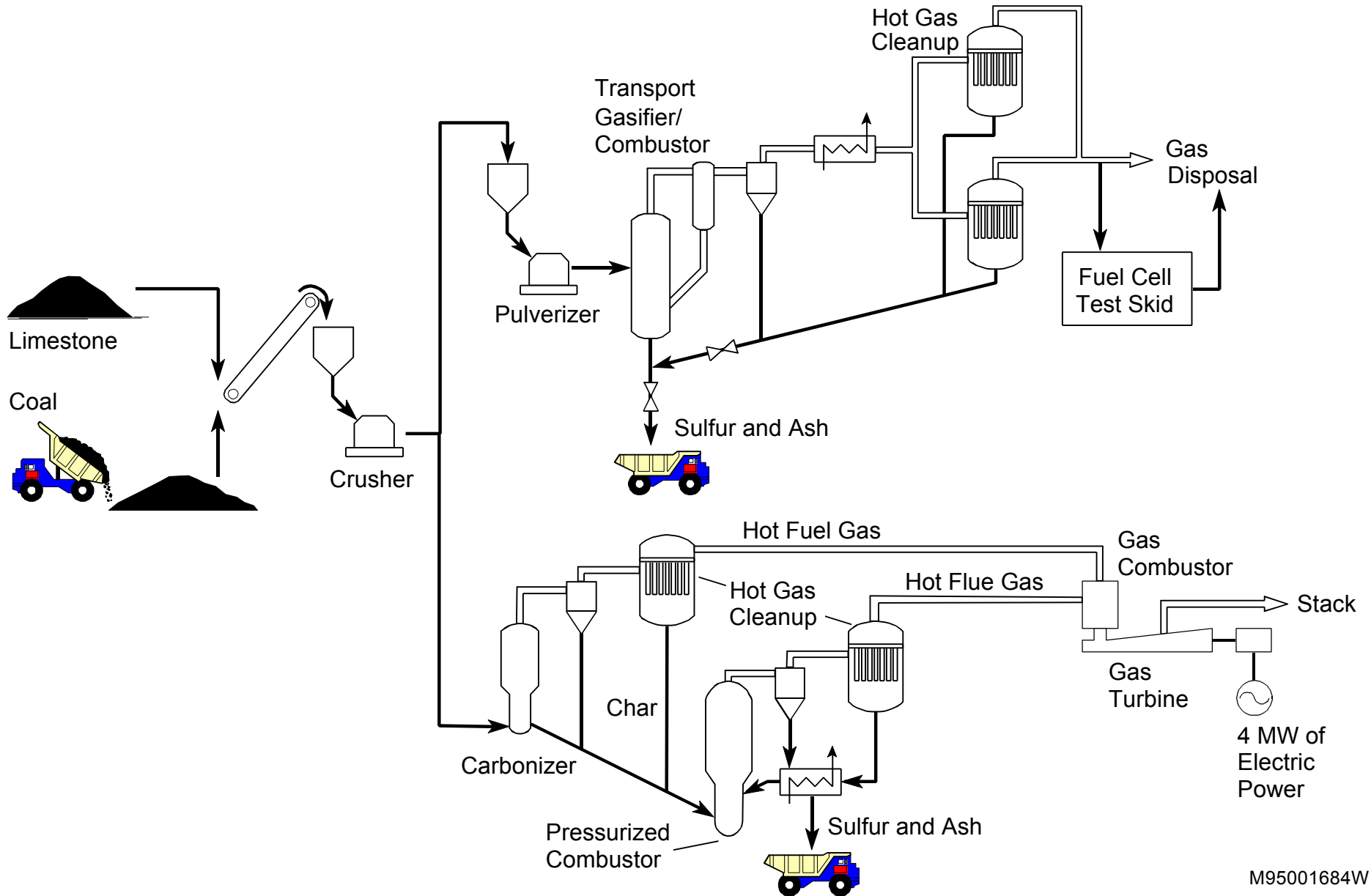

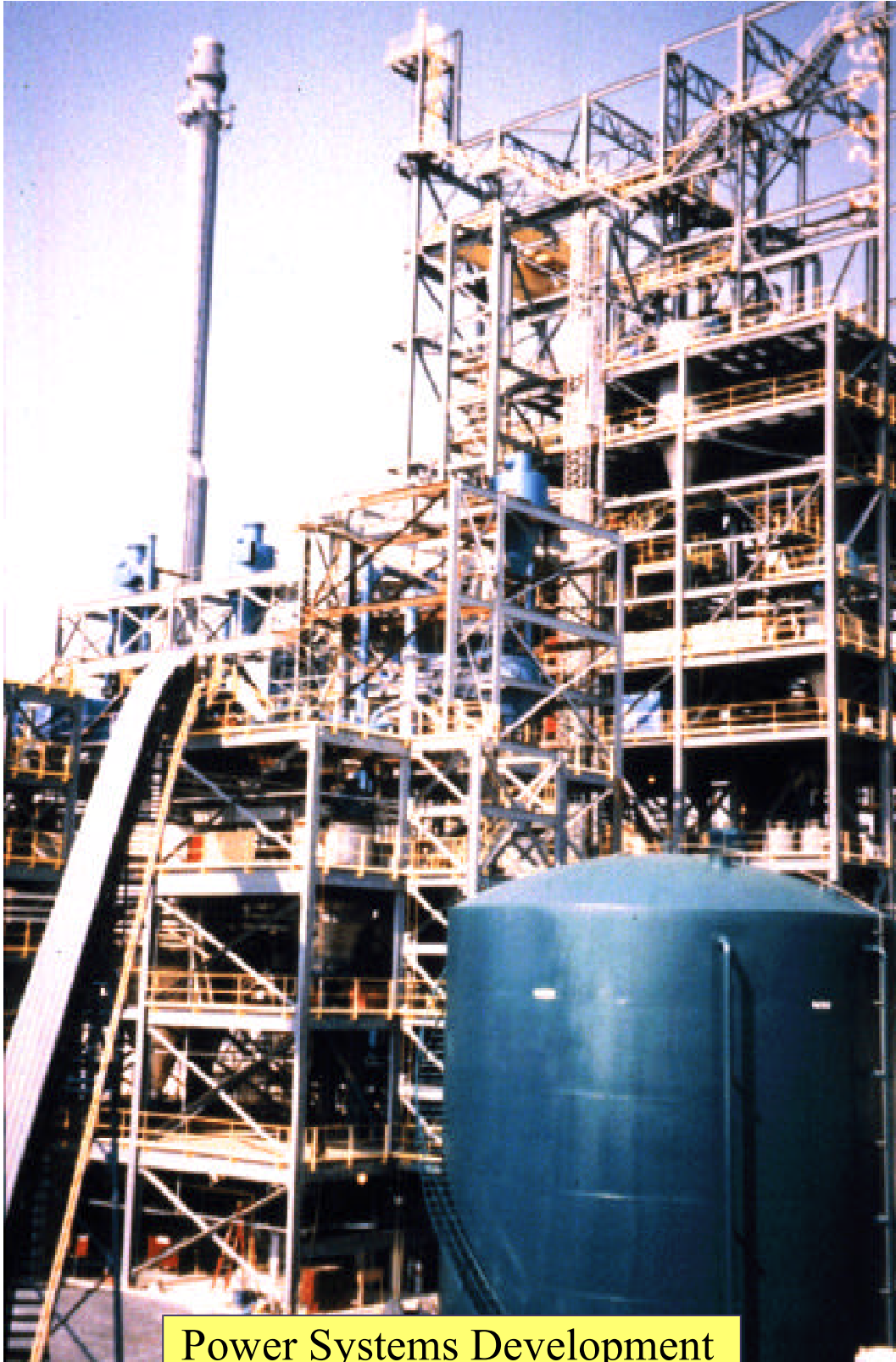

Power Systems Development  
Facility at Wilsonville, AL

# GEESI Moving Bed Desulfurizer

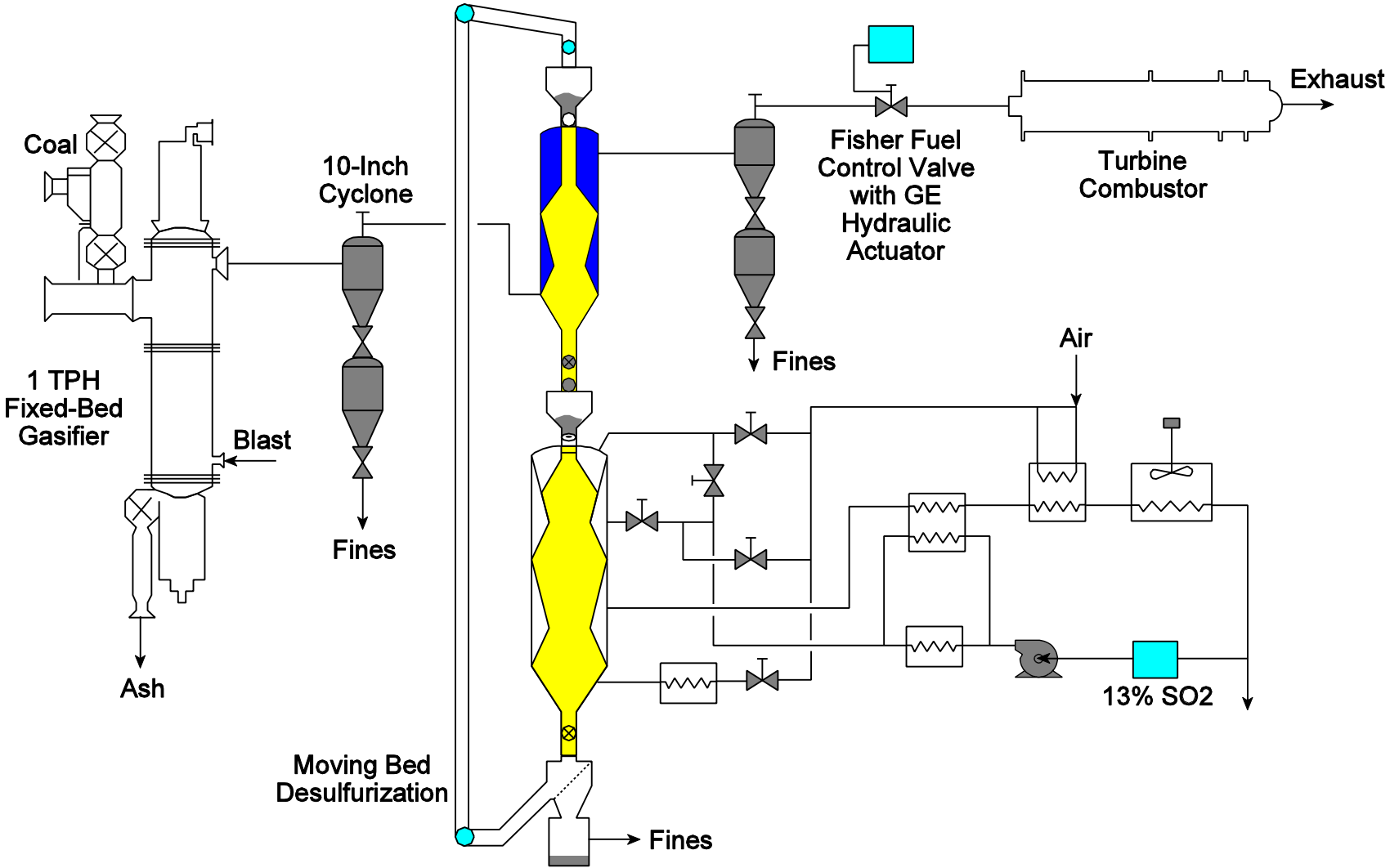

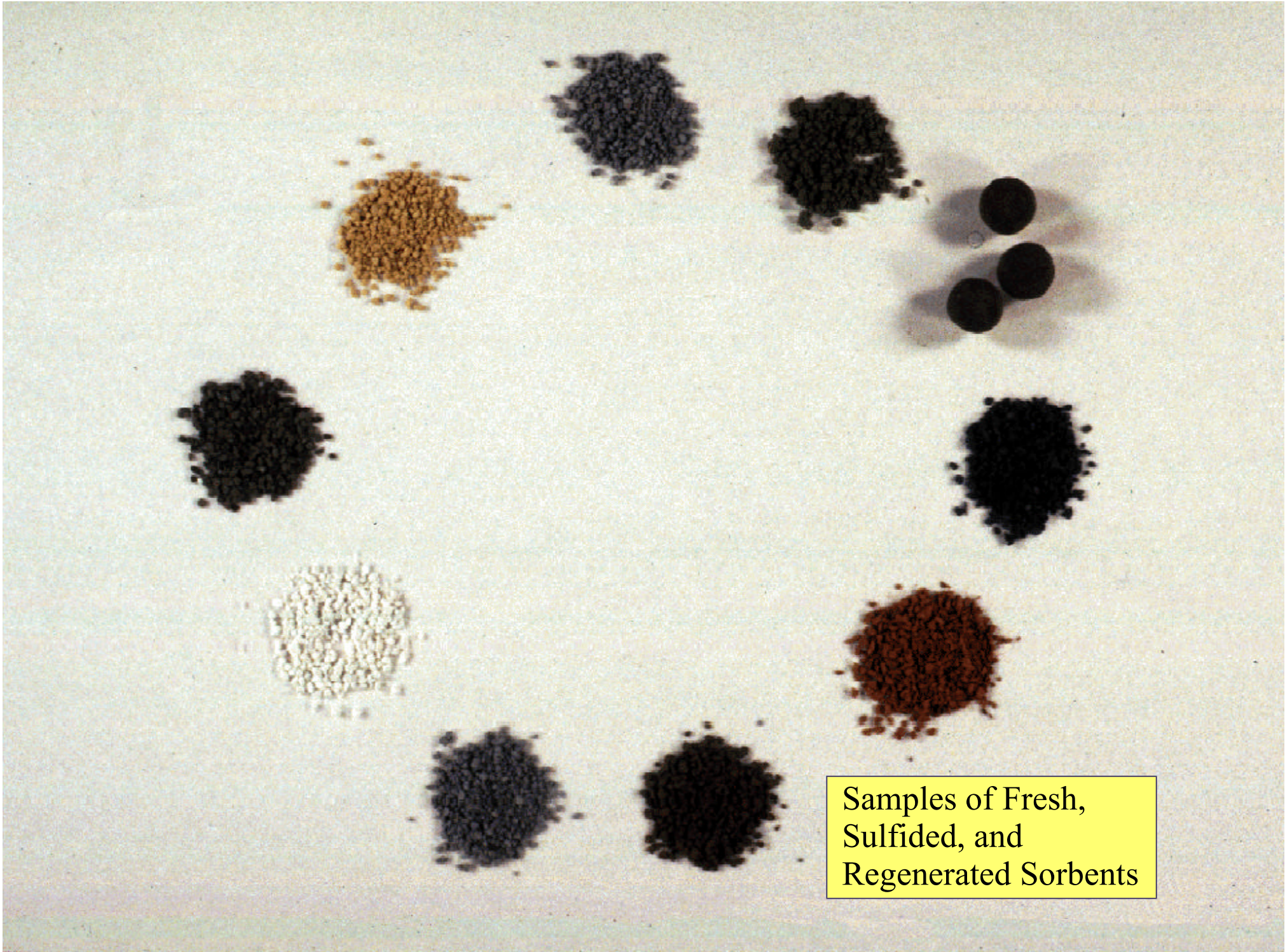

Samples of Fresh,  
Sulfided, and  
Regenerated Sorbents

# *PDU Reactor Schematic*

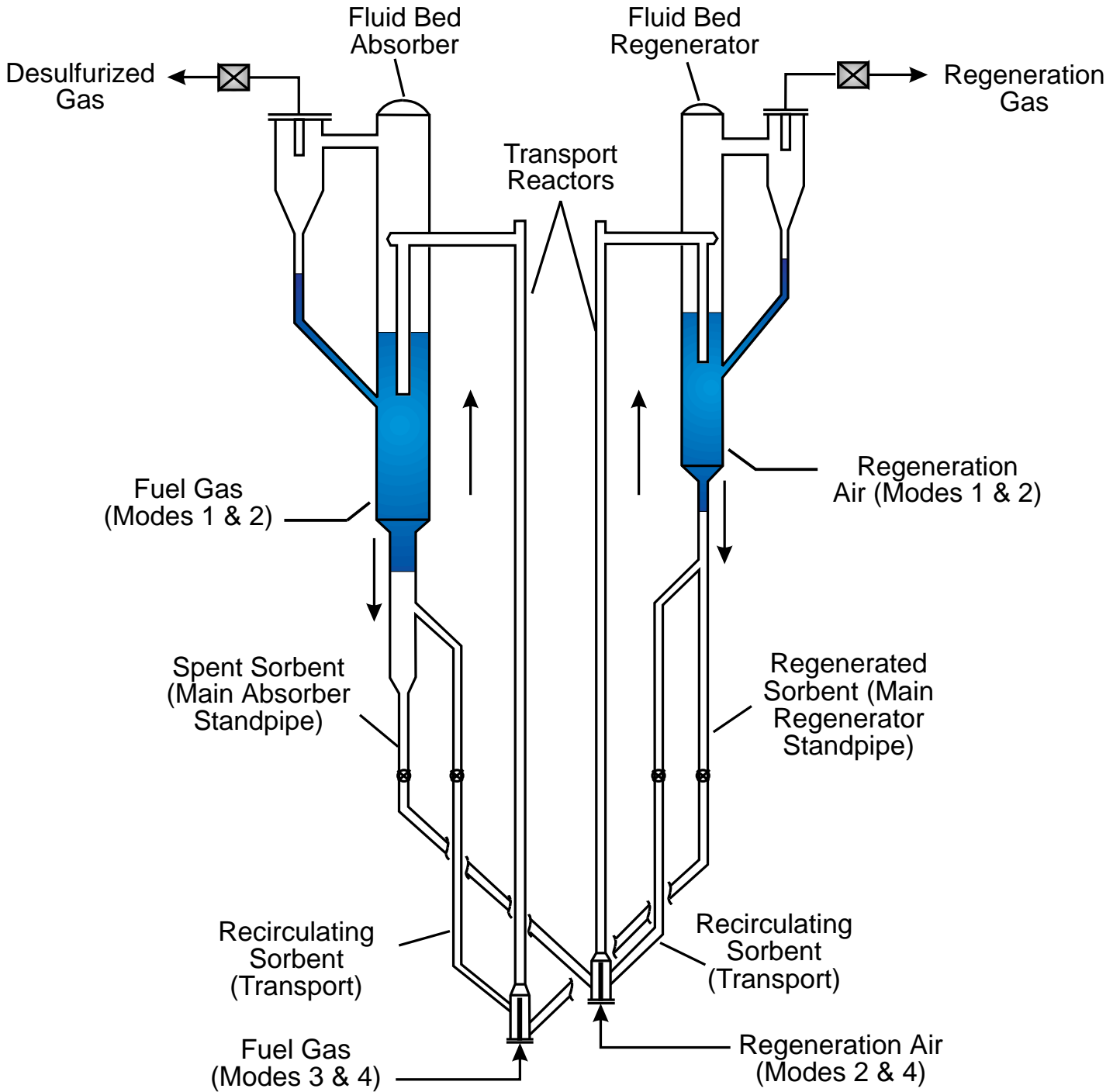



METC  
Desulfurization PDU

# Transport Reactor with Hot-Gas Filter System

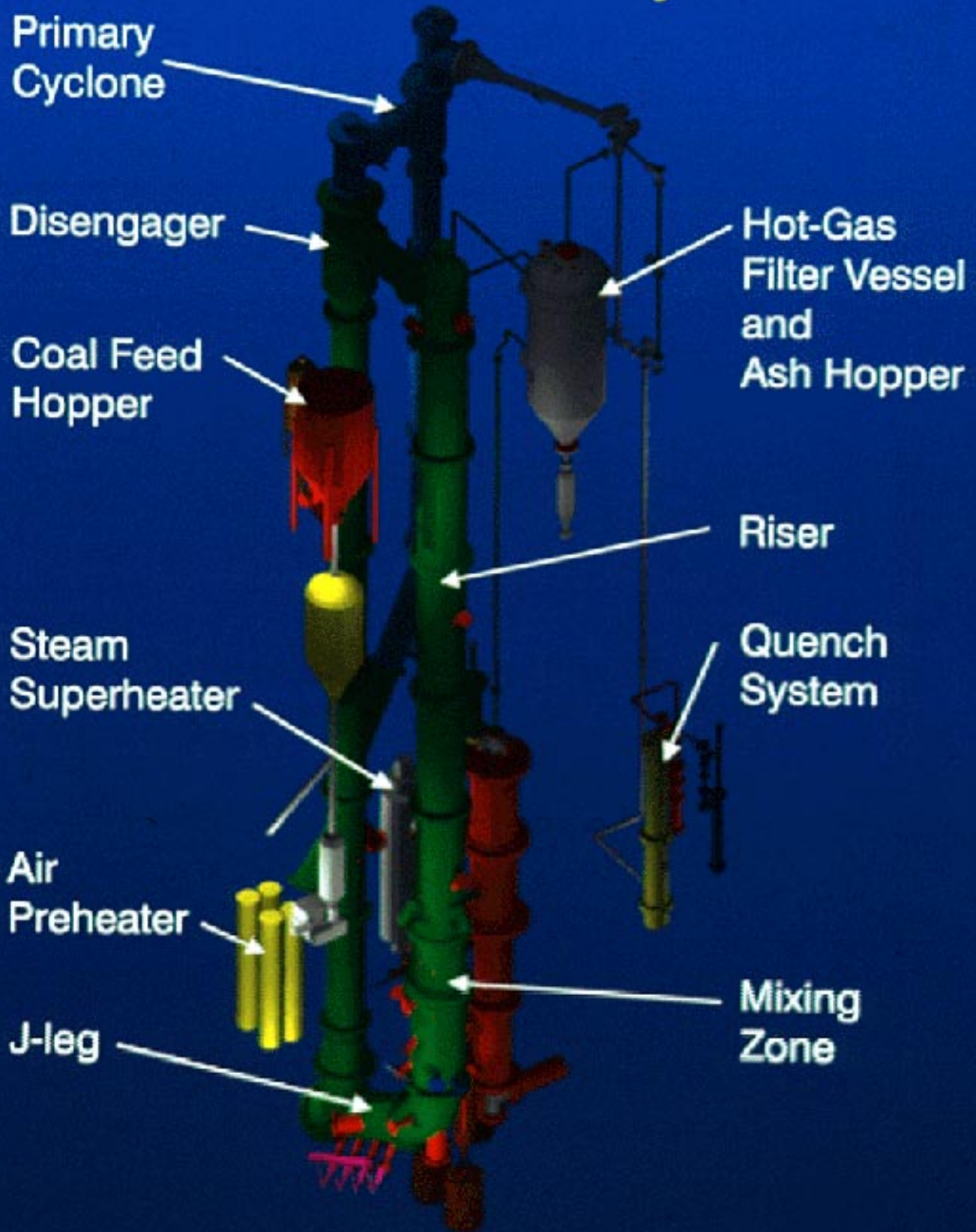



UNDEERC  
Transport  
Reactor PDU



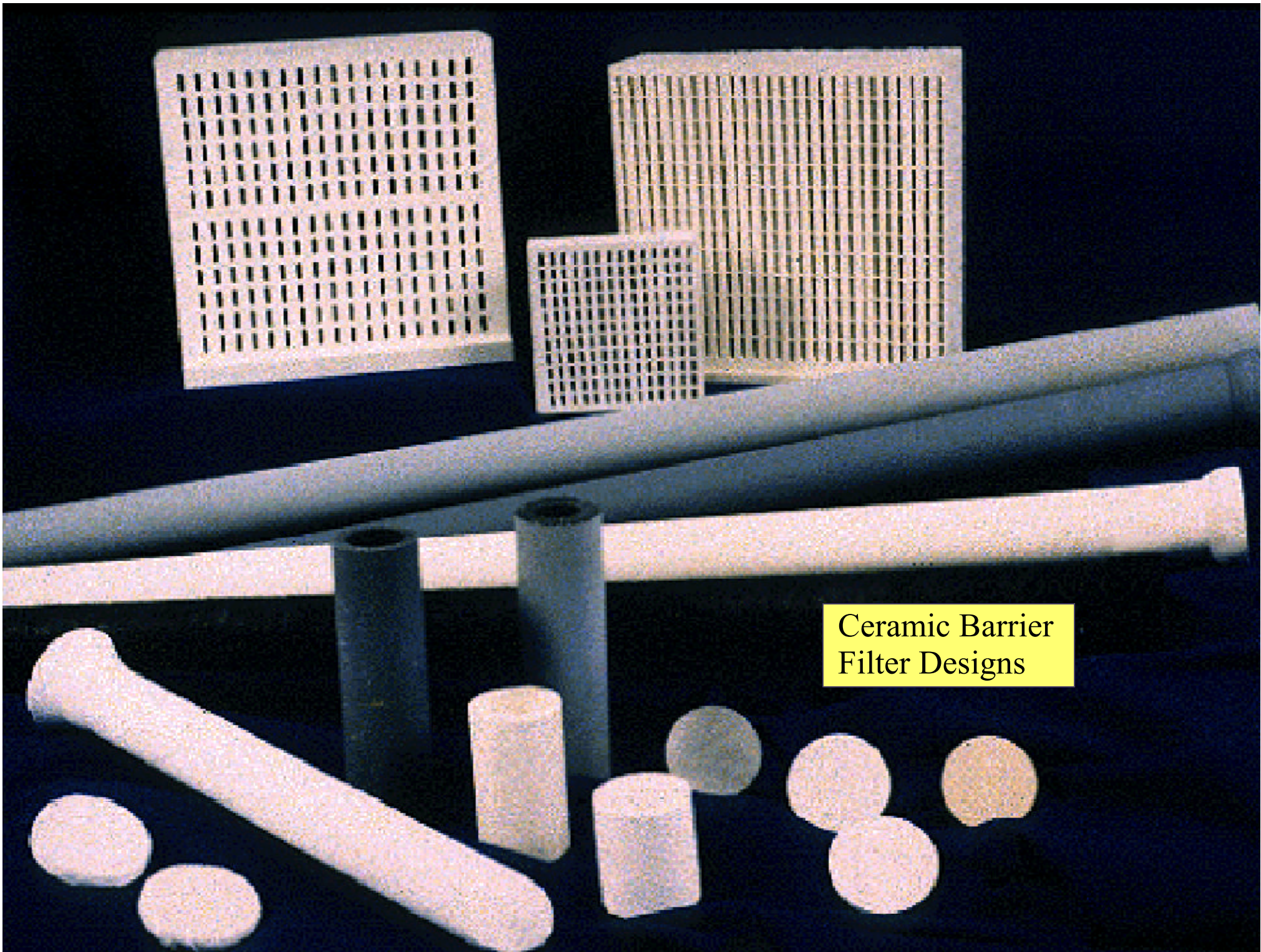

Ceramic Barrier  
Filter Designs



Westinghouse Cold Flow Filter Module

## TIDD PFBC Ceramic Filter Test Slipstream

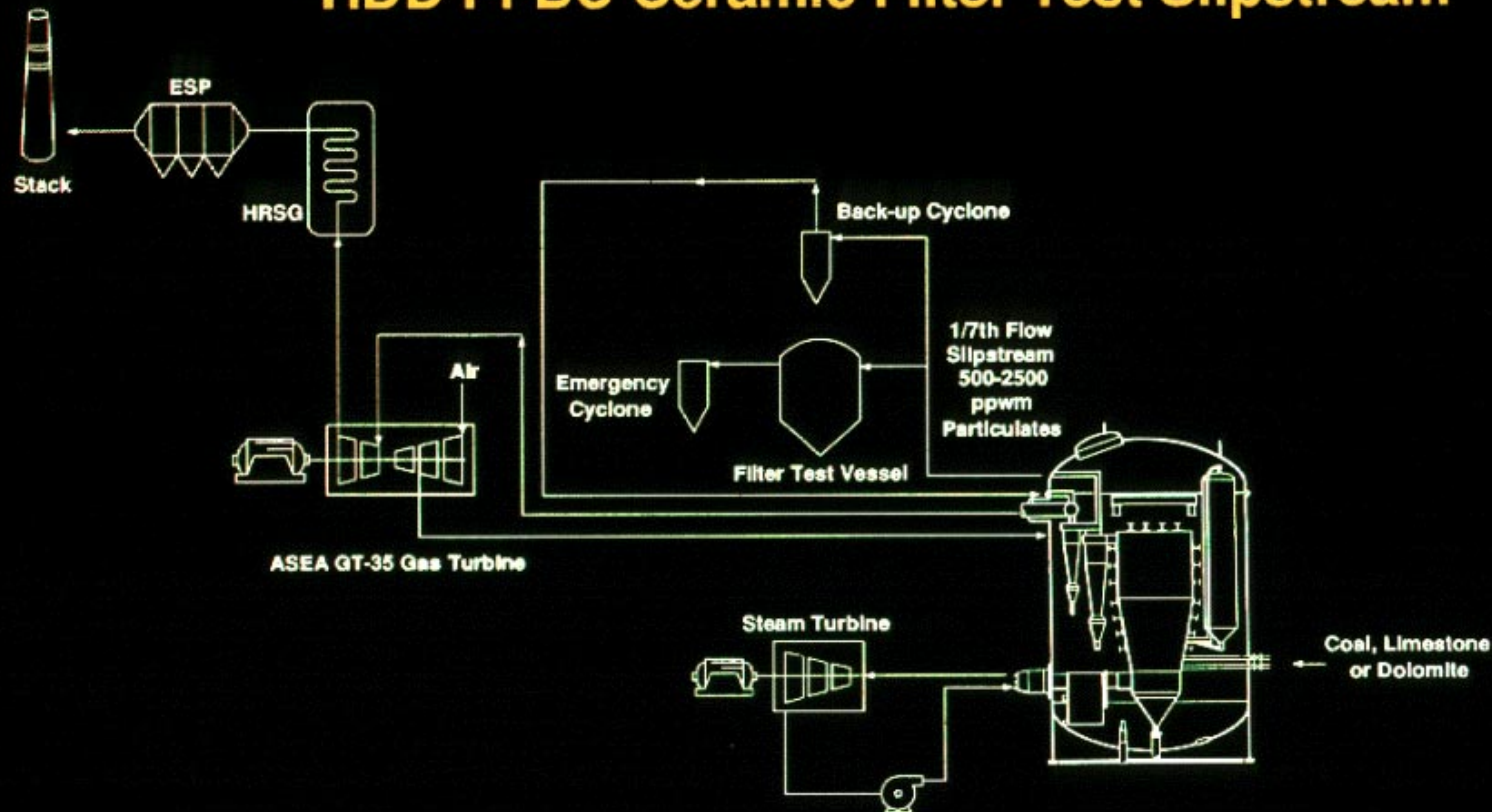

- Conduct large-scale engineering tests of ceramic filter systems for commercial 1st & 2nd Generation PFBC
  - Demonstrate 5,000 hours of operation
- \$20 million program separate from Clean Coal
- Test filters on 2nd & 3rd years of operation
- Westinghouse ceramic candle filters first system to be tested
- Potential for a different filter in 2nd test period

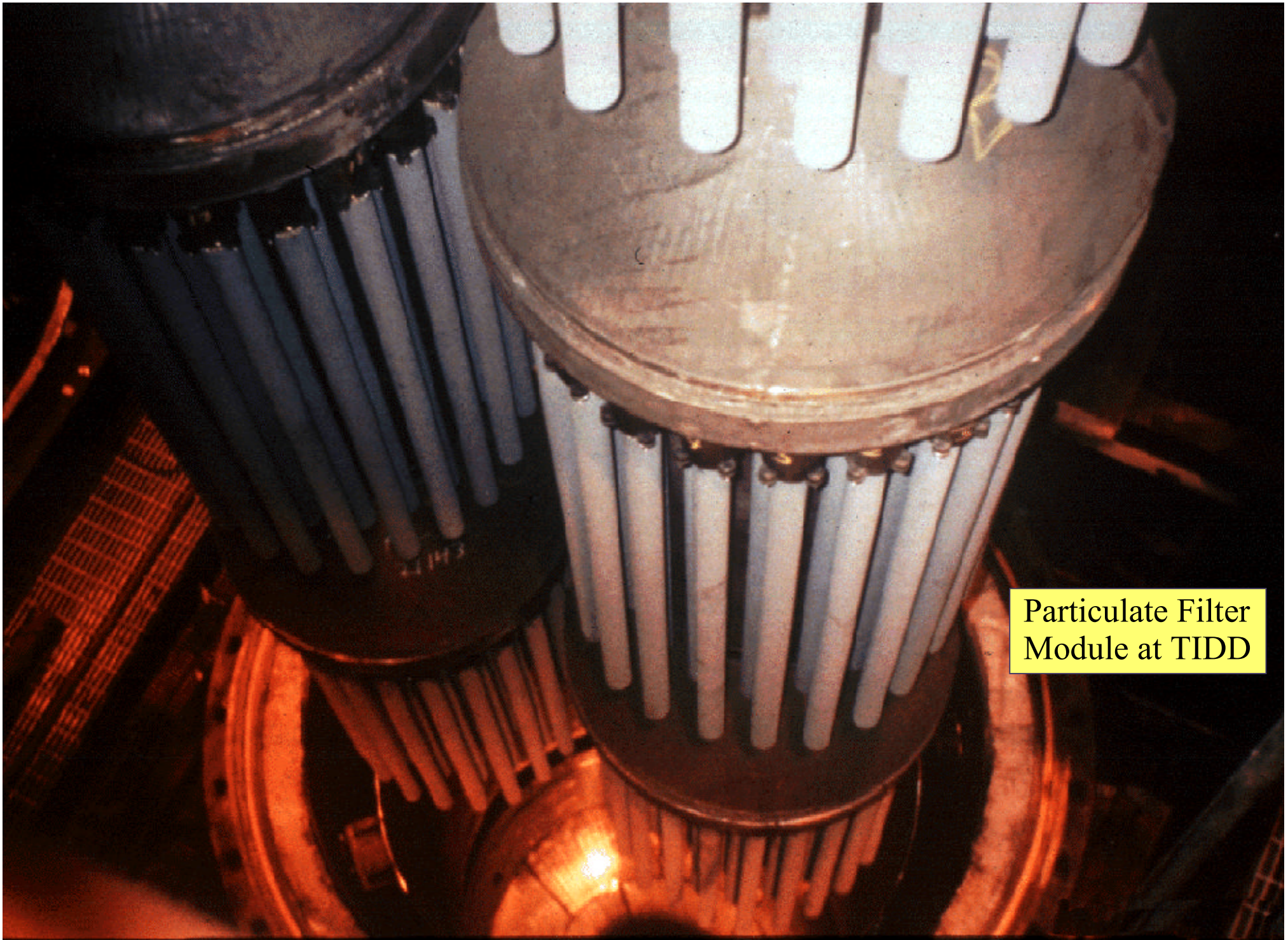

Particulate Filter  
Module at TIDD

# KARHULA

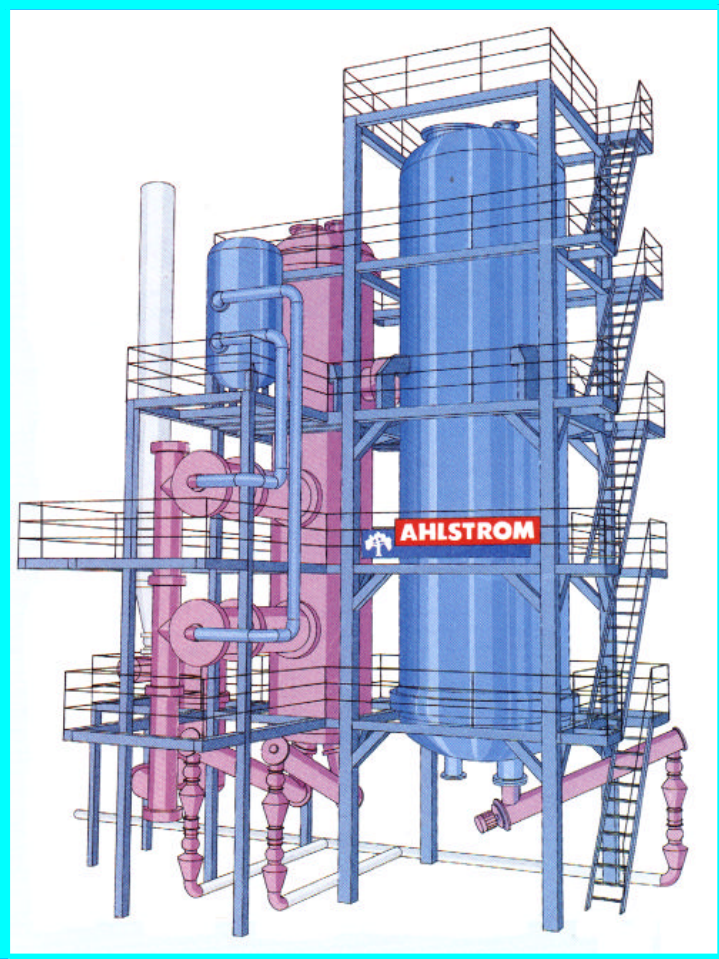

M96001848C

# ***Barrier Issues***

- ***Technical***
  - ***Filters***
  - ***CO<sub>2</sub>***
  - ***S and other gases***
  - ***Materials***
  
- ***Market***
  - ***Domestic capacity growth***
  - ***Capital cost***
  - ***Incentive for risk***

# IGCC R&D Issues

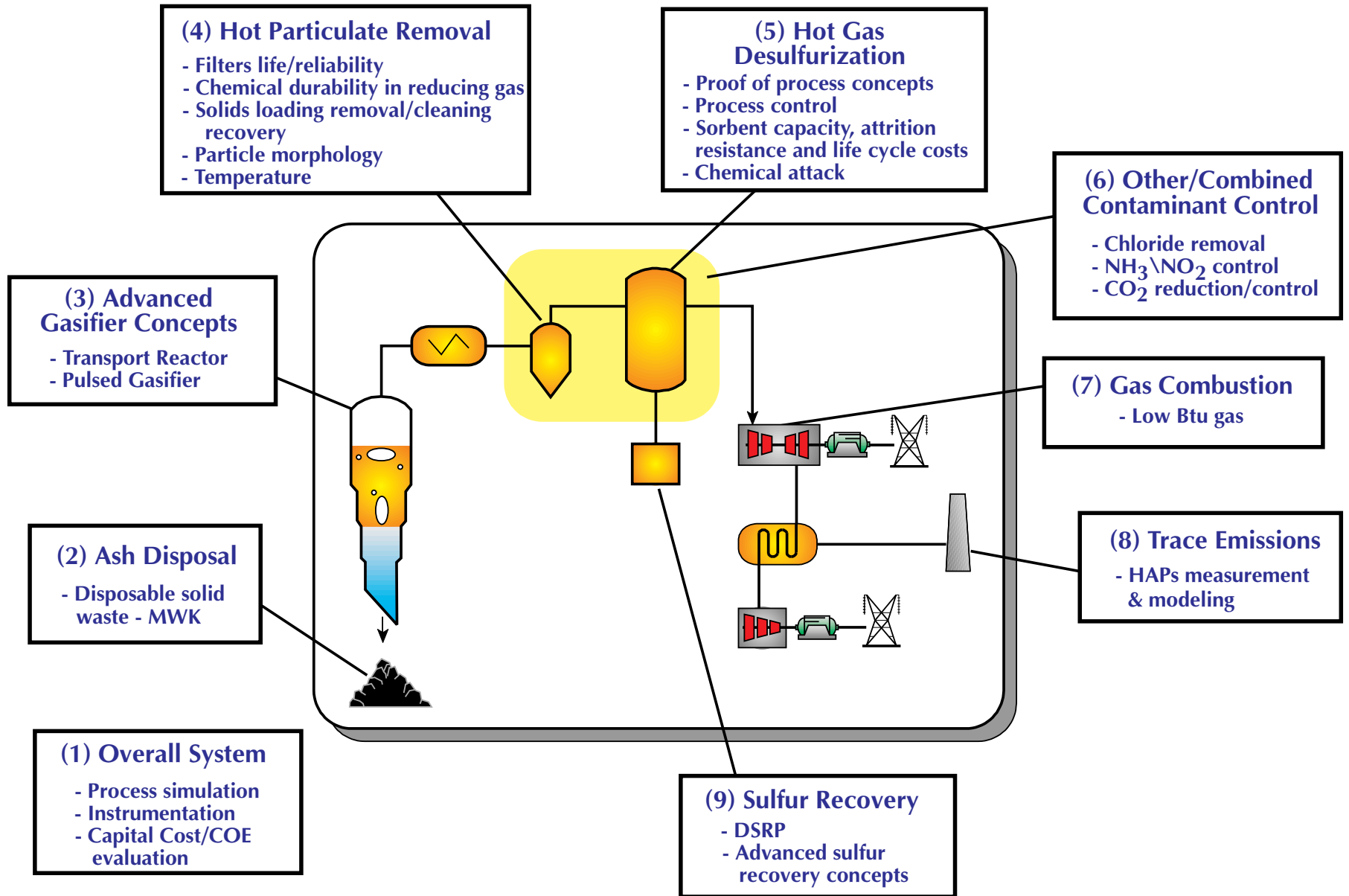



# PFBC R&D Issues

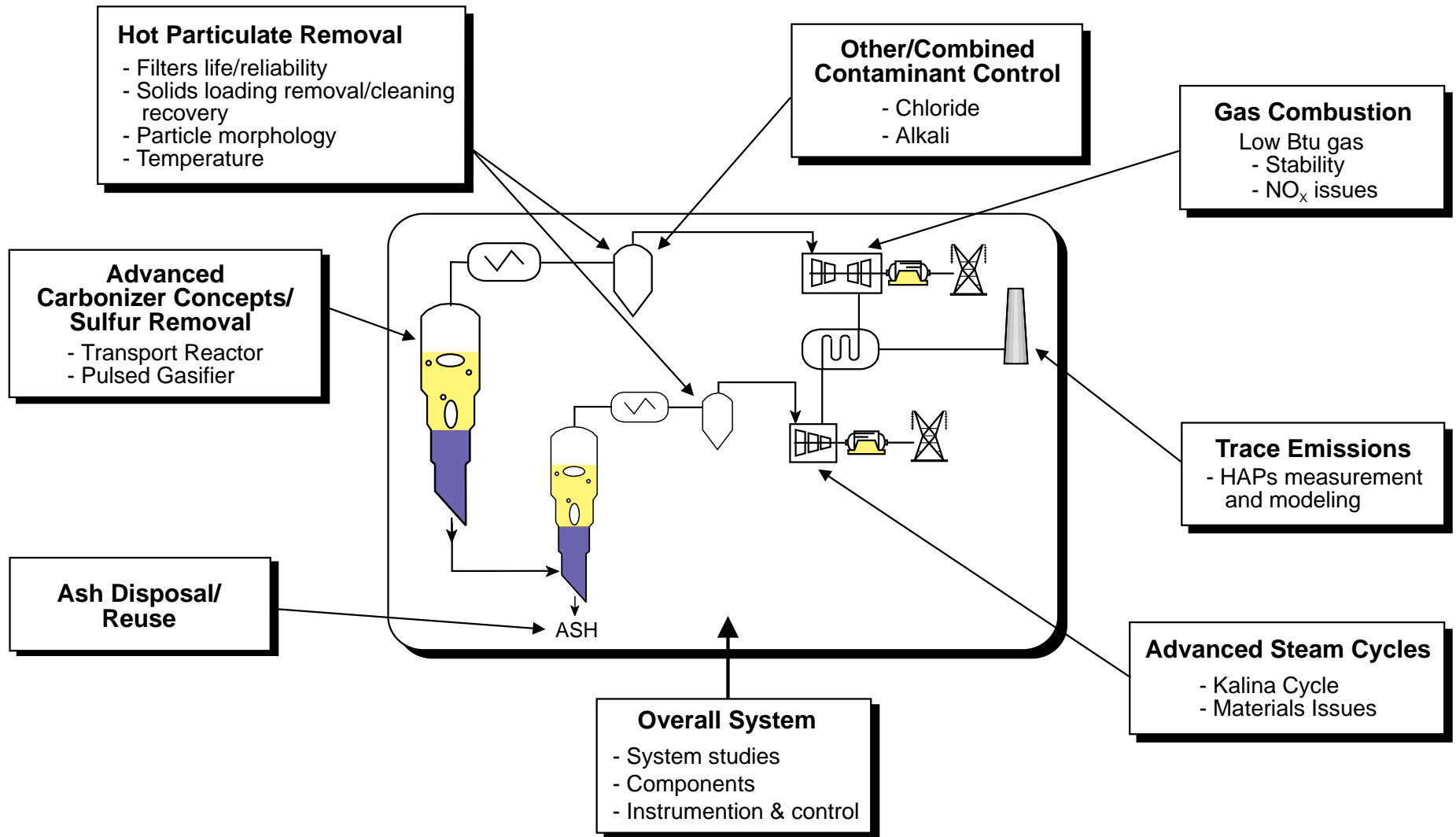

# *Key Plans*

- *Startups*
  - *Tampa*
  - *Piñon*
  - *PSDF*
- *Construction*
  - *Lakeland*
  - *Seward*
- *Testing*
  - *Filter Materials*



Wabash River Coal Gasification  
Repowering Project

Piñon Pine IGCC  
Power Project

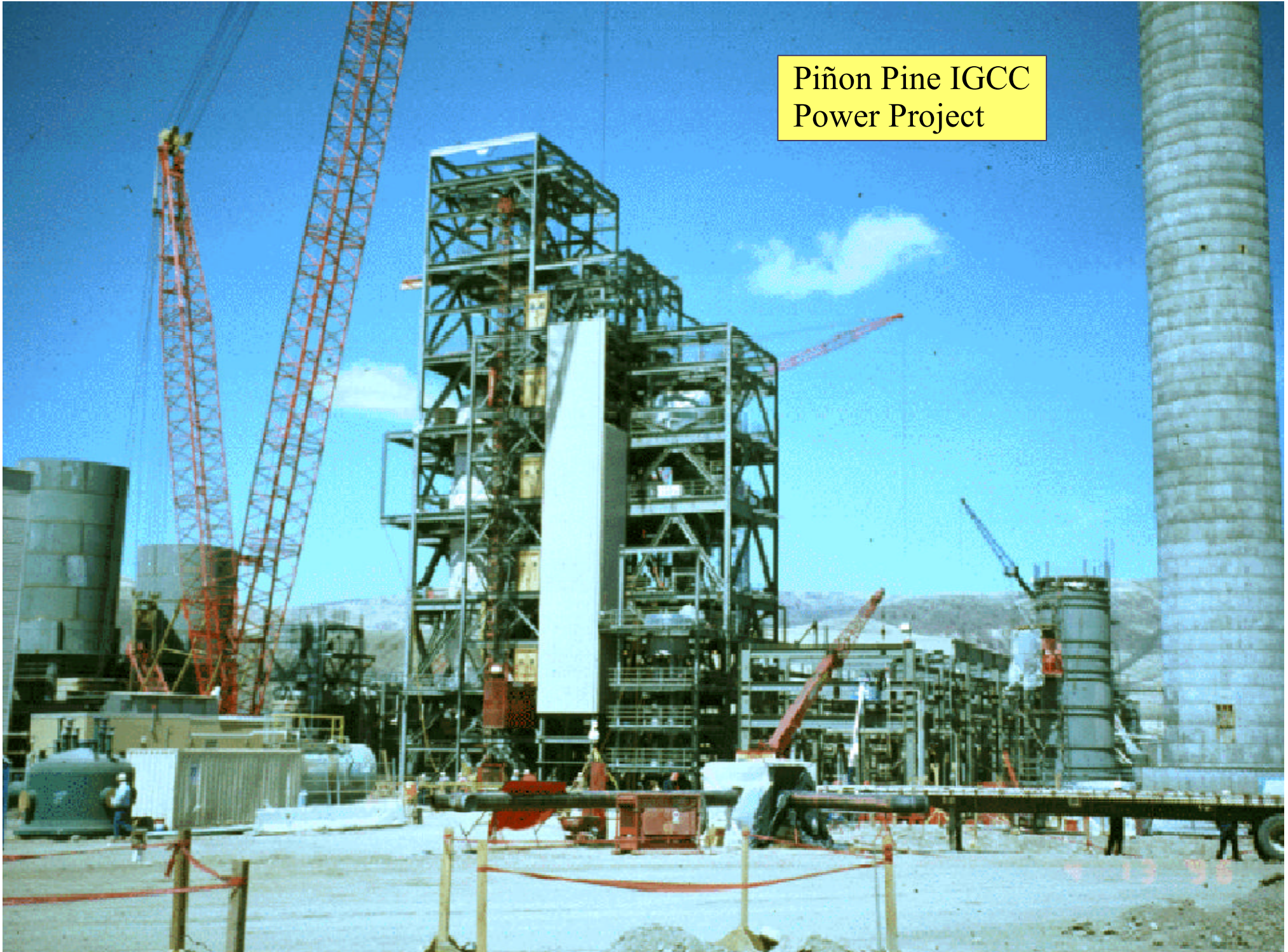

Tampa Electric Integrated  
Gasification Combined  
Cycle Project

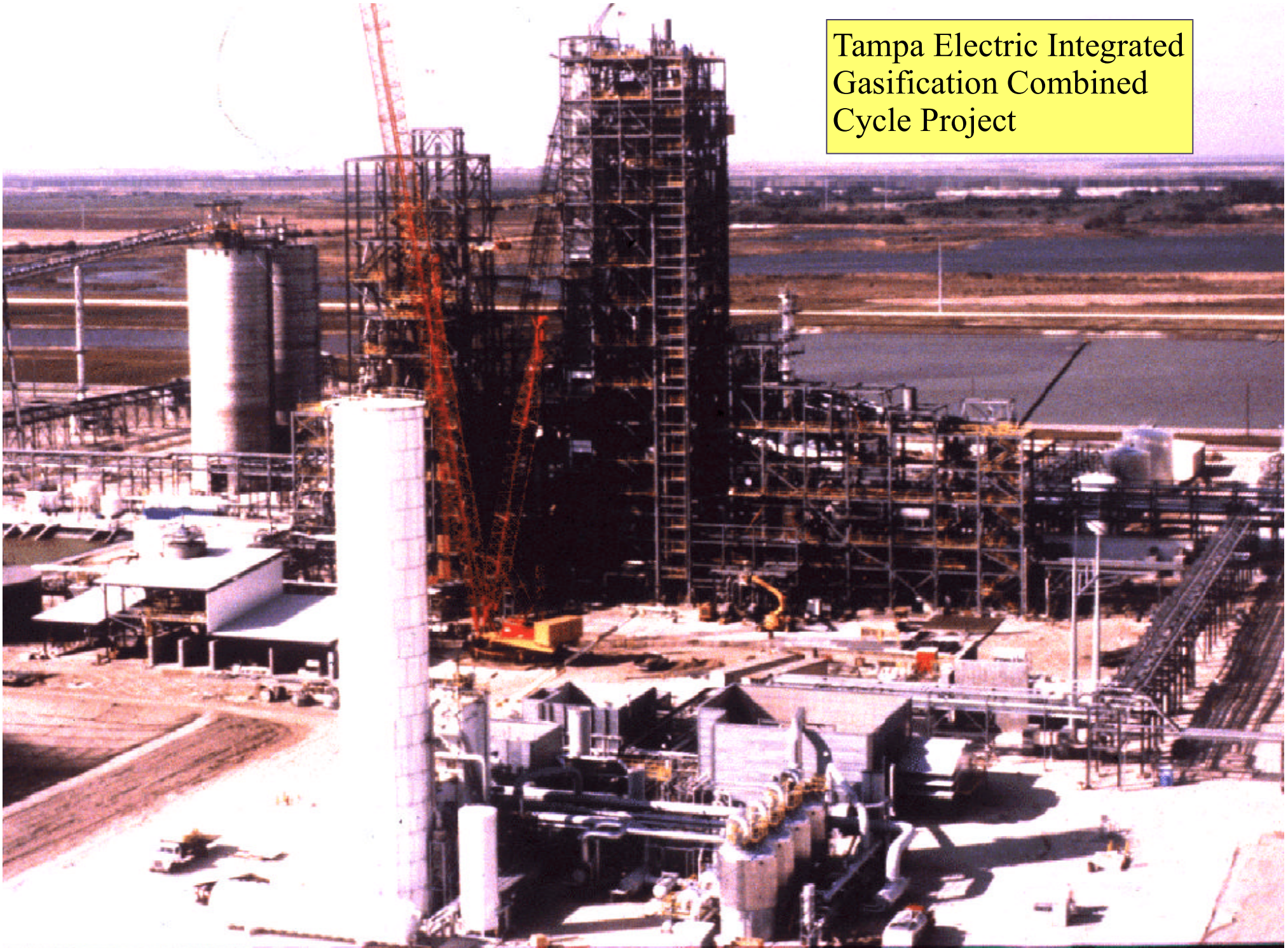

City of Lakeland  
McIntosh Power Plant  
Lakeland, Florida  
March 4, 1996

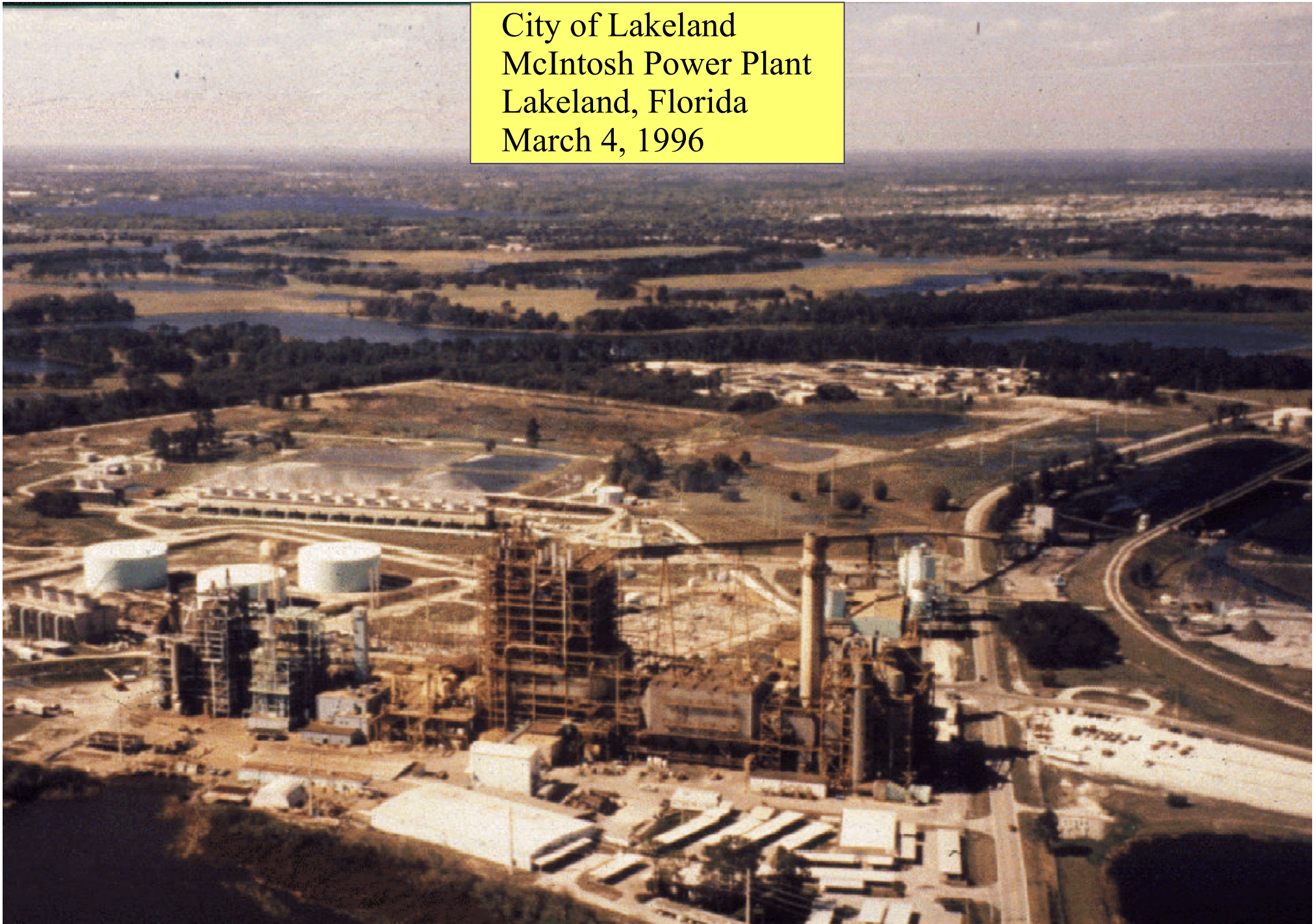

# List of IGCC Projects in the World

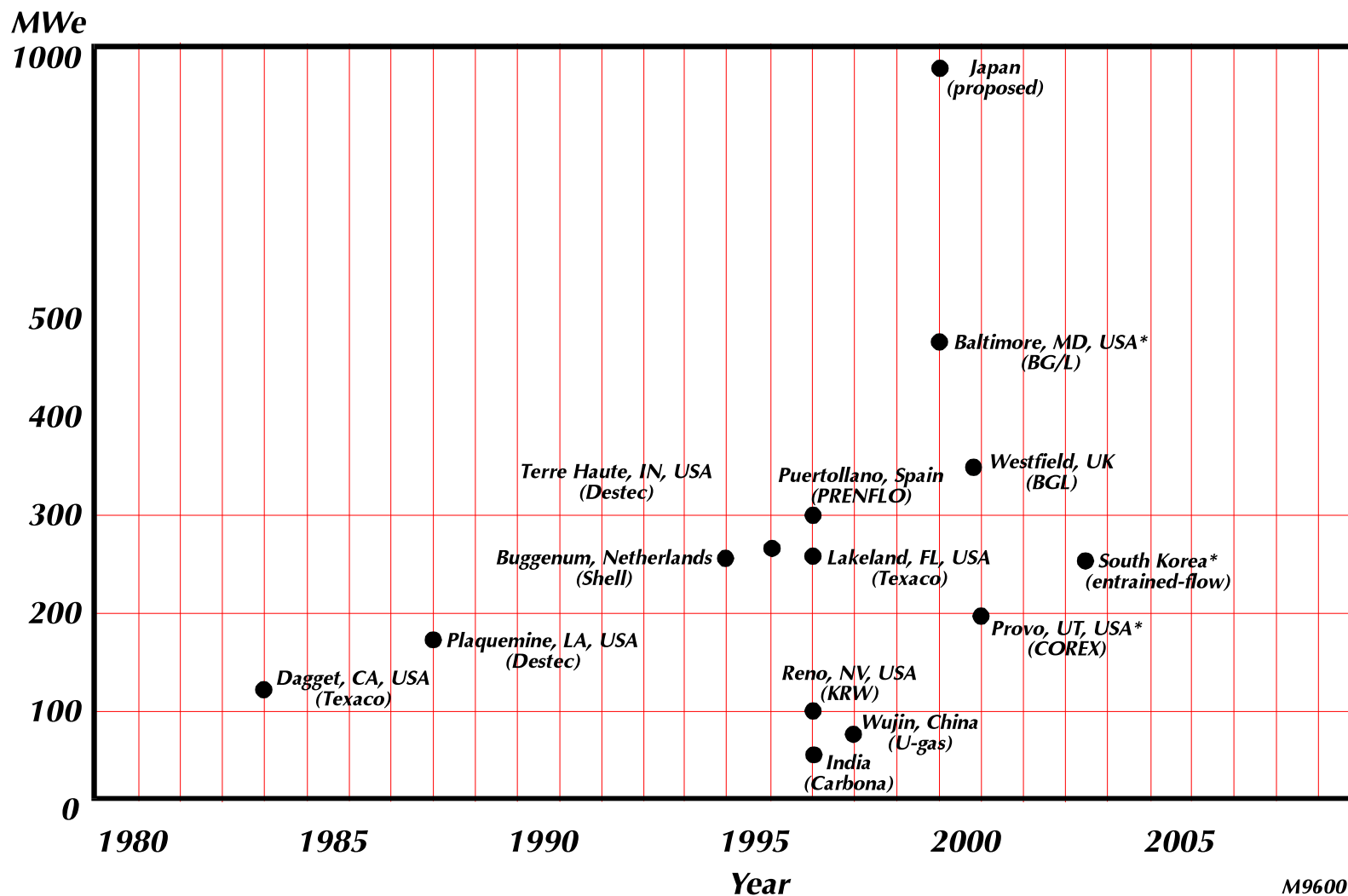

# ***IGCC Plants and Projects***





# List of PFBC Projects in the World

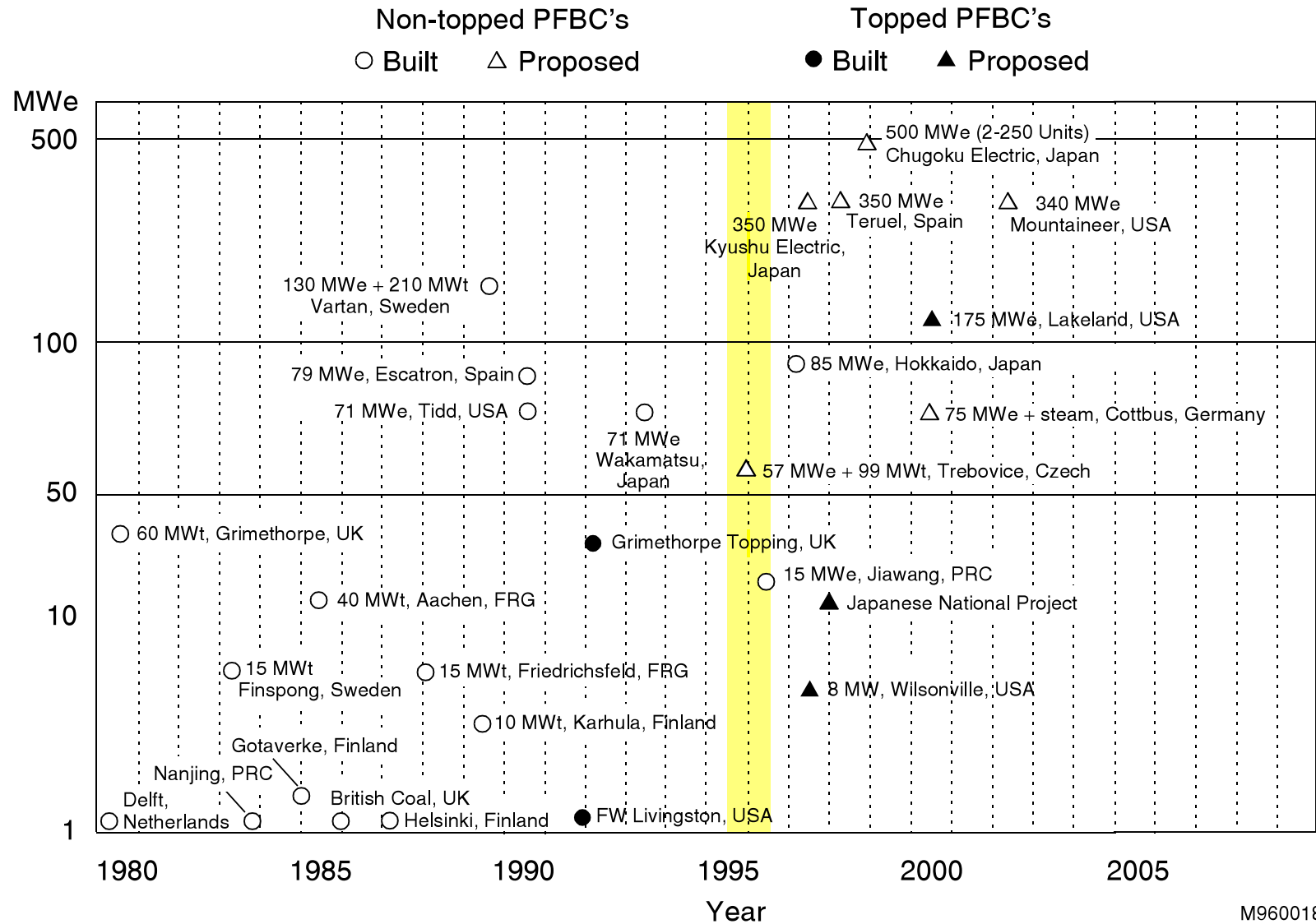

# ***PFBC Plants and Projects***

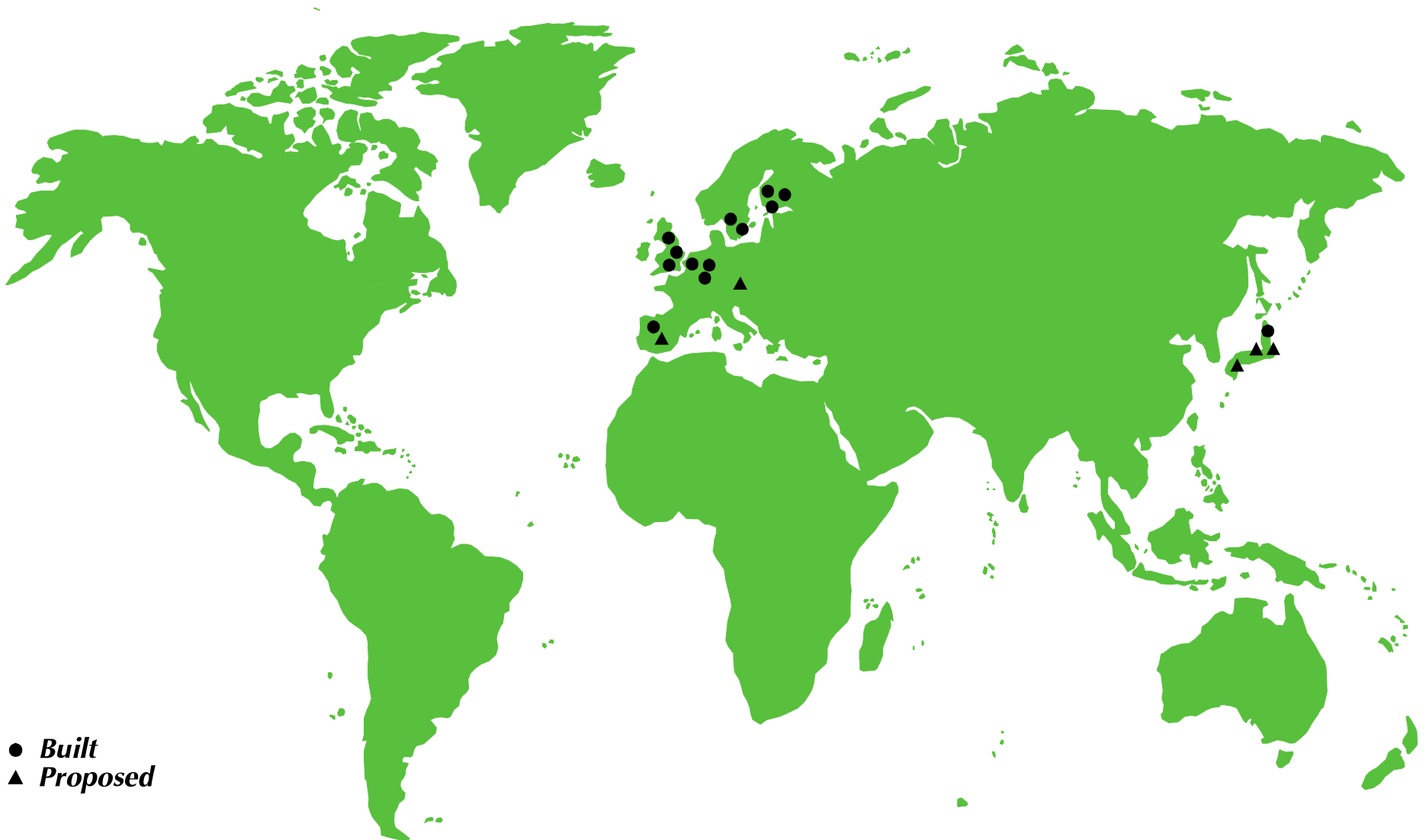

● ***Built***  
▲ ***Proposed***

# ***Marketplace Opportunities***

- ***U.S. repowering***
- ***Global demand***
- ***Co-production***
- ***Opportunity fuels***
- ***Environmental drivers***
- ***Advanced systems***

# Global Demand

**World Electricity Consumption  
1970 - 2015**

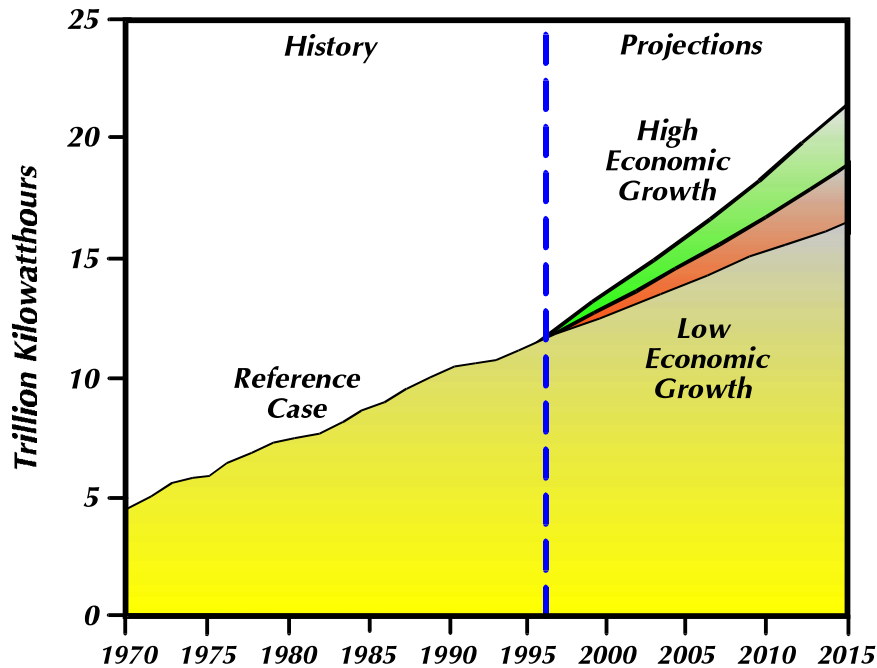

**Non-OECD Electricity Consumption  
By Region, 1993 - 2015**

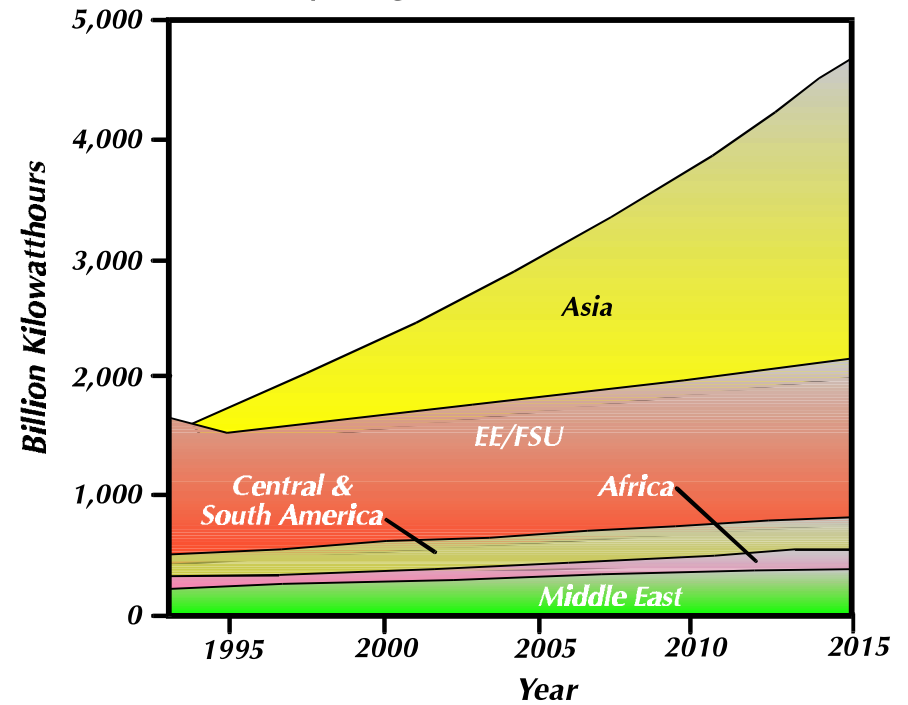

Source: History: Energy Information Administration (EIA) International Energy Annual 1993, DOE/EIA-0219(93) (Washington, D.C., May 1995). Projections: EIA, World Energy Projection System (1996).

# *U.S. Repowering*

## *Plants Over 40 Years Old*

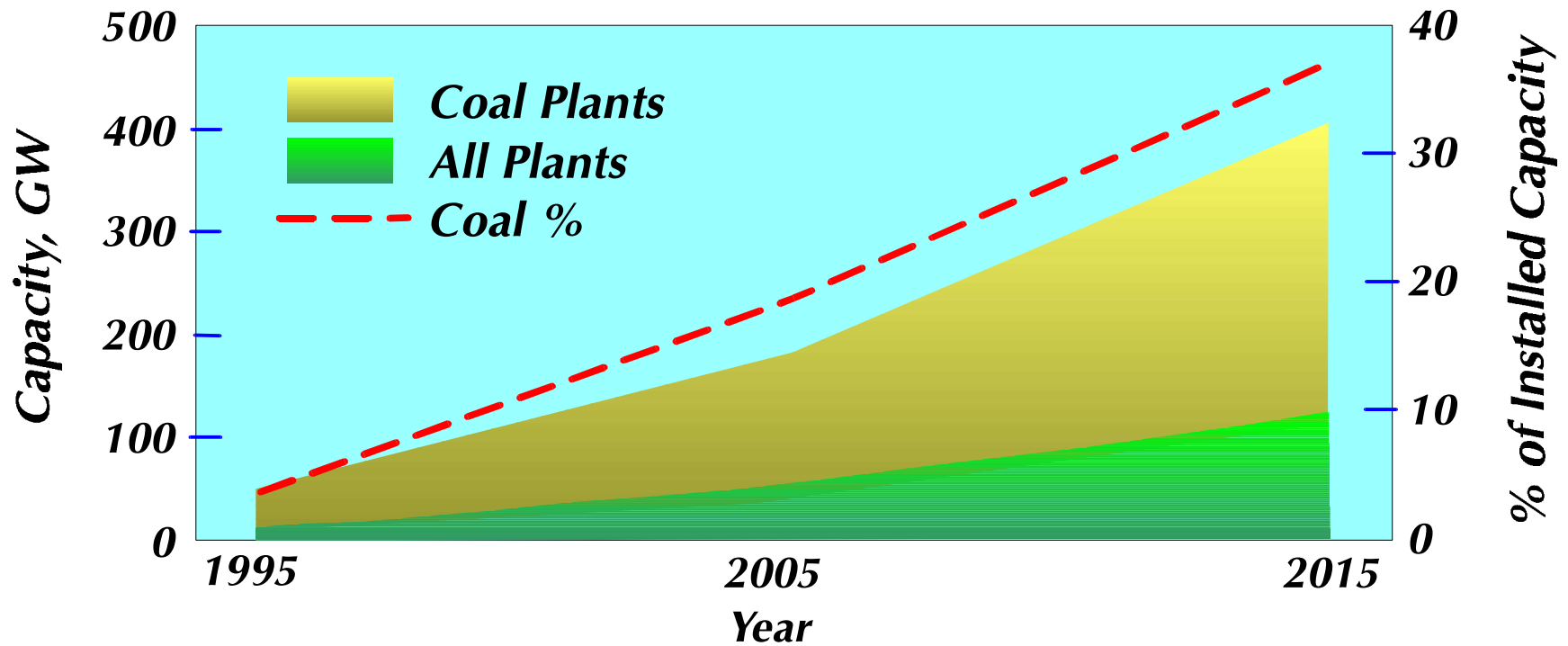

# ***Co-Production***

**COAL**



***Electricity***

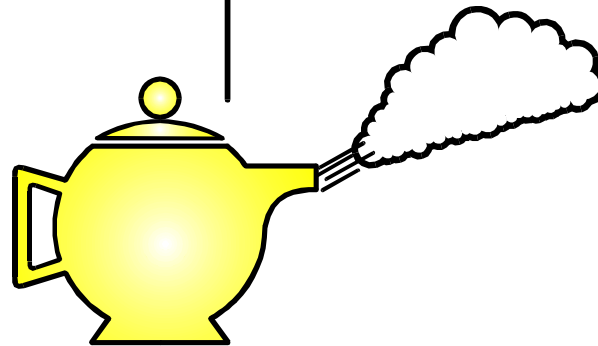

***Steam***

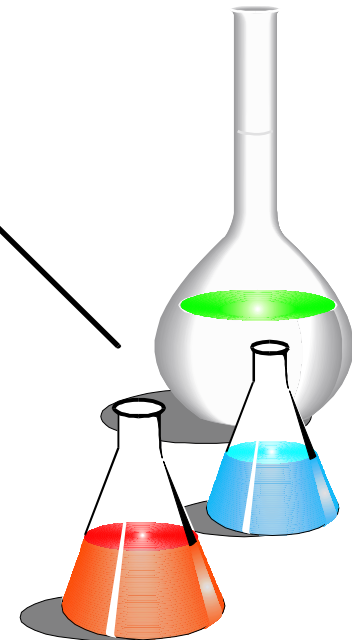

***Chemicals***



## *Opportunity Fuels*

- Plastic
- Biomass
- Sewage
- RDF
- Petcoke
- Waste Fuel

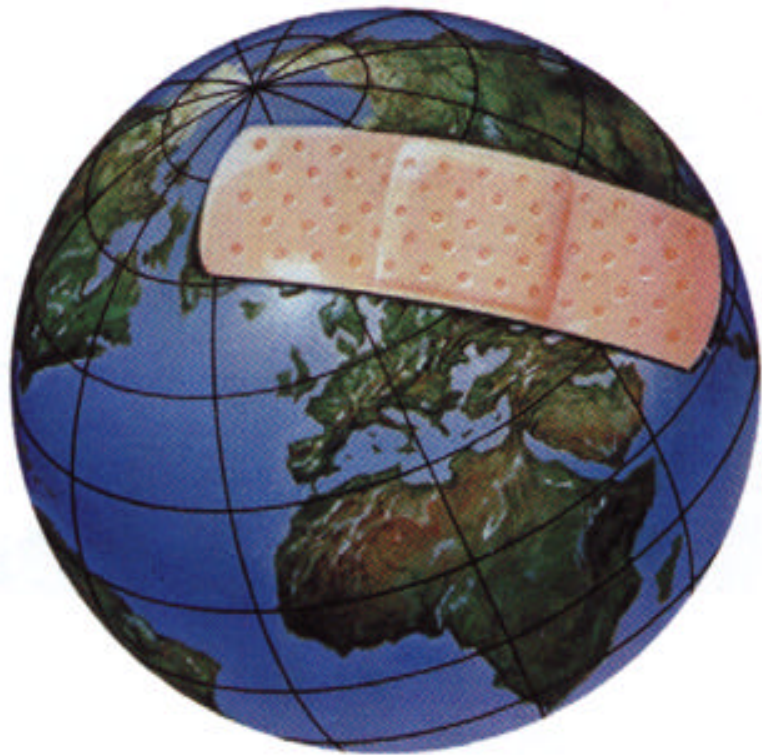

## ***Environmental Drivers***

- **SO<sub>2</sub>**
- **NO<sub>x</sub>**
- **CO<sub>2</sub>**
- **Particulates**
- **HAPs**



# Advanced Systems

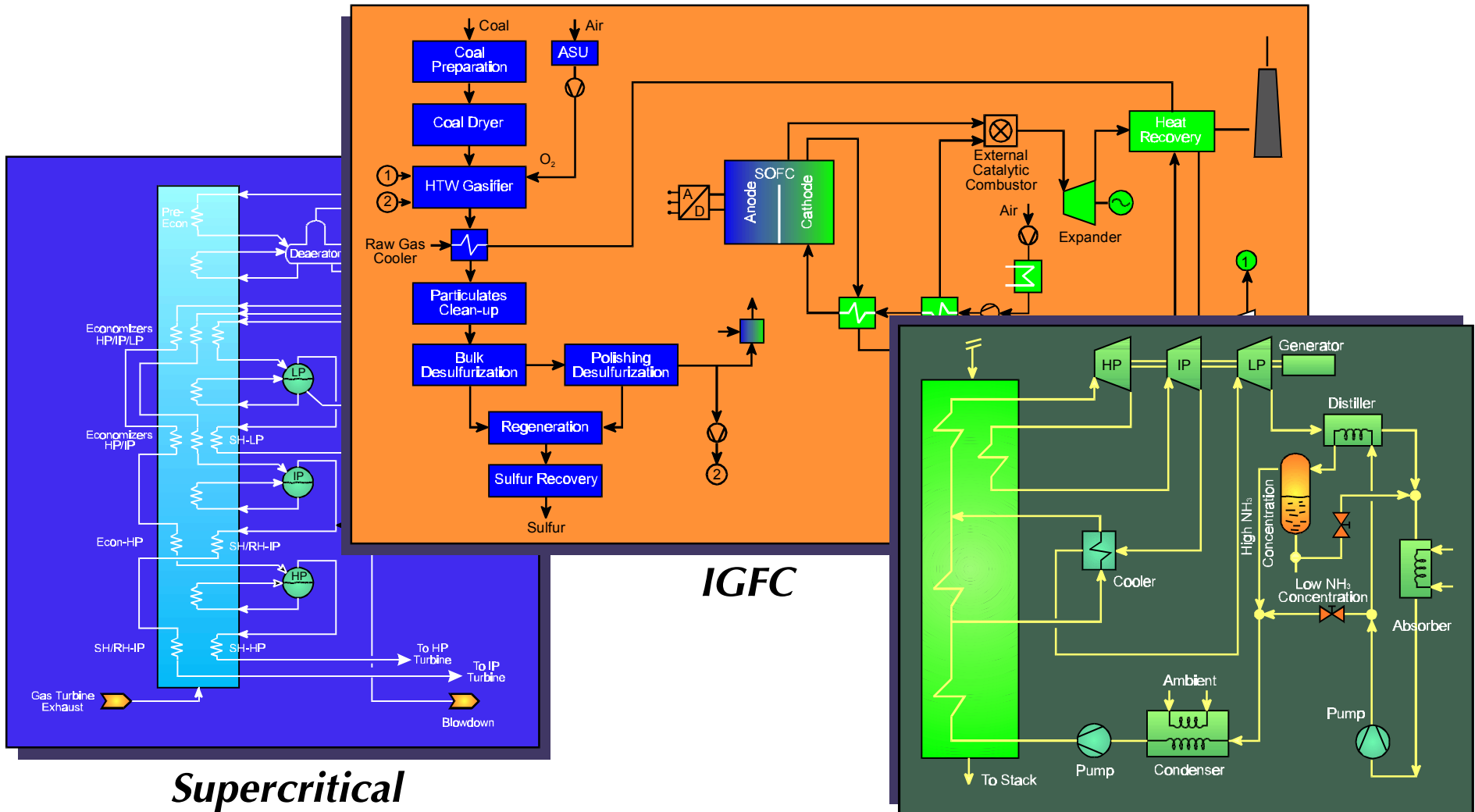

**Supercritical**

**IGFC**

**Kalina and Other Advanced Cycles**