

4.5 Meter High-Level Waste Canister Study

R. B. Calmus
G. N. Boechler
SGN Eurisys Services Corporation

Date Published
September 1997

Prepared for the U.S. Department of Energy
Assistant Secretary for Environmental Management

Project Hanford Management Contractor for the
U.S. Department of Energy under Contract DE-AC06-96RL13200

Approved for public release; distribution is unlimited

LEGAL DISCLAIMER

This report was prepared as an account of work sponsored by an agency of the United States Government. Neither the United States Government nor any agency thereof, nor any of their employees, nor any of their contractors, subcontractors or their employees, makes any warranty, express or implied, or assumes any legal liability or responsibility for the accuracy, completeness, or any third party's use or the results of such use of any information, apparatus, product, or process disclosed, or represents that its use would not infringe privately owned rights. Reference herein to any specific commercial product, process, or service by trade name, trademark, manufacturer, or otherwise, does not necessarily constitute or imply its endorsement, recommendation, or favoring by the United States Government or any agency thereof or its contractors or subcontractors. The views and opinions of authors expressed herein do not necessarily state or reflect those of the United States Government or any agency thereof.

This report has been reproduced from the best available copy. Available in paper copy and microfiche.

Available to the U.S. Department of Energy
and its contractors from
U.S. Department of Energy
Office of Scientific and Technical Information (OSTI)
P.O. Box 62
Oak Ridge, TN 37831
(615) 576-8401

Available to the public from the U.S. Department of Commerce
National Technical Information Service (NTIS)
5285 Port Royal Road
Springfield, VA 22161
(703) 487-4650

Printed in the United States of America

DISCLM-1.CHP (8-95)

RELEASE AUTHORIZATION

Document Number: HNF-SP-1243, Rev. 0

Document Title: 4.5 Meter High-Level Waste Canister Study

This document, reviewed in accordance with DOE Order 1430.1D, "Scientific and Technical Information Management," and DOE G 1430.1D-1, "Guide to the Management of Scientific and Technical Information," does not contain classified or sensitive unclassified information and is:

APPROVED FOR PUBLIC RELEASE

Christine W. Ingham

10/1/97

Lockheed Martin Services, Inc.
Document Control/Information Clearance

Reviewed for Applied Technology, Business Sensitive, Classified, Copyrighted, Export Controlled, Patent, Personal/Private, Proprietary, Protected CRADA, Trademark, Unclassified Controlled Nuclear Information.

LEGAL DISCLAIMER. This report was prepared as an account of work sponsored by an agency of the United States Government. Neither the United States Government nor any agency thereof, nor any of their employees, nor any of their contractors, subcontractors or their employees, makes any warranty, express or implied, or assumes any legal liability or responsibility for the accuracy, completeness, or any third party's use or the results of such use of any information, apparatus, product, or process disclosed, or represents that its use would not infringe privately owned rights. Reference herein to any specific commercial product, process, or service by trade name, trademark, manufacturer, or otherwise, does not necessarily constitute or imply its endorsement, recommendation, or favoring by the United States Government or any agency thereof or its contractors or subcontractors. The views and opinions of authors expressed herein do not necessarily state or reflect those of the United States Government or any agency thereof. This report has been reproduced from the best available copy. Printed in the United States of America.

INFORMATION ONLY COPY

Christine Killingsland

WORK REQUEST	
Date:	10-1-97 7:30 am - 7:55
Name:	R. B. Calmus
Company:	SESC H5-27 376-5017
Org Code:	SS150000 6A240011
Charge Code:	X D4KH D4NKH
Work Requested:	Clean ANF-SP-1243 4.5 Meter High Level waste Container Study " General Council Review IRAD data entry Prepare Release Authorization Make copy for scanning
INFORMATION ONLY COPY	
Print Name	Ron B. Calmus
Signature	<i>Ronald B. Calmus</i>

Date Received by IRA
10-1-97

INFORMATION RELEASE REQUEST - (Long Form)

(GRAY SHADED AREAS NOT TO BE FILLED IN BY INITIATOR)

1. COMPLETE THIS SECTION FOR ALL DOCUMENTS

A. Information Category		B. Document ID Number (include rev., vol., etc.)
Speech or Presentation		HNF-SP-1243
<input type="checkbox"/> Full Paper <input type="checkbox"/> Summary <input type="checkbox"/> Abstract <input type="checkbox"/> Visual Aid	<input type="checkbox"/> Journal Article <input type="checkbox"/> Multimedia Presentation <input type="checkbox"/> Software	C. List attachments (i.e., copyright permission, copyright transfer)
<input checked="" type="checkbox"/> Other <u>Engineering Study</u>		

D. Document Title	E. WHC Project or Program
4.5 Meter High-Level Waste Canister Study	Immobilized HLW Storage Subproject

F. New or novel (patentable) subject matter? If "Yes", has disclosure been submitted by WHC? <input type="checkbox"/> No or Yes If "Yes", Disclosure No(s): _____	<input checked="" type="checkbox"/> No or Yes	G. Information received from others in confidence, such as proprietary data, and/or inventions? <input type="checkbox"/> No or Yes If "Yes", contact WHC General Counsel.
---	---	--

H. Copyrights? <input checked="" type="checkbox"/> No or Yes If "Yes", attach permission.	I. Trademarks? <input checked="" type="checkbox"/> No or Yes If "Yes", identify in document.
---	--

2. COMPLETE THIS SECTION FOR ALL DOCUMENTS REQUIRING SUBMISSION TO OSTI

A. Unclassified Category	B. Budget & Reporting Code
UC - 2030	B&R - EW3130010

3. COMPLETE THIS SECTION ONLY FOR A JOURNAL SUBMISSION

A. Title of Journal

4. COMPLETE THIS SECTION ONLY FOR A SPEECH OR PRESENTATION

A. Title for Conference or Meeting	B. Group or Society Sponsoring
C. Date(s) of Conference or Meeting	D. City/State
E. Will material be published in proceedings? <input type="checkbox"/> No or Yes Will material be handed out? <input type="checkbox"/> No or Yes	

5. REVIEWS

Reviewers	Yes	Signature indicates Approval as Requested unless otherwise indicated: Name (print)	Signature/Date	Limited-Use Info.
General Counsel	<input checked="" type="checkbox"/>	<i>C. Willingham</i>	<i>Chris Willingham 10-1-97</i>	<input type="checkbox"/>
DOE-RL	<input type="checkbox"/>			<input type="checkbox"/>
Communications	<input type="checkbox"/>			<input type="checkbox"/>
Applied Technology Export Controlled Information or International Program	<input type="checkbox"/>			<input type="checkbox"/>
Other	<input type="checkbox"/>			<input type="checkbox"/>
Other	<input type="checkbox"/>			<input type="checkbox"/>

6. Applied Technology Material Referenced
<input checked="" type="checkbox"/> No <input type="checkbox"/> Yes

7. Release Level
<input checked="" type="checkbox"/> Public <input type="checkbox"/> Limited Distribution

8. Author/Requestor
R. B. Calmus <i>RB Cal</i> <i>9/30/97</i>
(Print and Sign) Date

9. Responsible Manager
K. C. Burgard <i>KC Burgard</i> <i>9/30/97</i>
(Print and Sign) Date

INFORMATION RELEASE ADMINISTRATION APPROVAL

IRA Approval is required before release. Release is contingent upon resolution of mandatory comments. NOTE: This block for IRA use only.



Date Cancelled	Date Disapproved
----------------	------------------

EXECUTIVE SUMMARY

The Tank Waste Remediation System (TWRS) Storage and Disposal Project has established the Immobilized High-Level Waste (IHLW) Storage Sub-Project to provide the capability to store Phase I and II HLW products generated by private vendors. A design/construction project, Project W-464, was established under the Sub-Project to provide the Phase I capability. Project W-464 will retrofit the Hanford Site Canister Storage Building (CSB) to accommodate the Phase I IHLW products. Project W-464 conceptual design is currently being performed to interim store 3.0 m-long HLW stainless steel canisters with a 0.61 m diameter. DOE is considering using a 4.5 m canister of the same diameter to reduce permanent disposal costs. This study was performed to assess the impact of replacing the 3.0 m canister with the 4.5 m canister. The summary cost and schedule impacts are described in the following paragraphs.

Cost Impact

Adding the 4.5 m canister to the Project W-464 baseline results in an estimated project cost impact of \$ - 425k (cost savings) to an increase of \$4,425k. This estimate is based on consideration of necessary modifications to project documents, conceptual design, capital equipment design and implementation, and required technical engineering studies.

The estimated impact breaks down as follows:

- Modifying baseline projects documents (i.e., design requirements document, supplemental conceptual design statement of work and work plan, and conceptual design update). Estimated cost: \$250k
- Perform additional engineering studies during the detailed design phase. Estimated Cost: \$335k
- Adding capital equipment needed to use a 4.5 m canister; the capital cost estimate reflects only the additional cost incurred if the 4.5 meter canisters are used. Estimated capital costs include design and implementation; Estimated total capital cost: \$-1,010 to \$3,940k

Primary capital equipment modifications or additions required to implement the 4.5 m canister are as follows:

- Reconfigure the internal material handling machine (MHM) body and grapple to allow for a 4.5 m overpacked canister or lengthen the MHM body. Shortening the MHM grapple effectively lengthens the internal cavity to accommodate the 4.5 m canister. This option essentially adds no weight. The worst case scenario is that

the modification would overstress the MHM and entire bridge and MHM would have to be replaced. Which options are viable is the major driver for the range of cost impacts.

- Design and fabricate a longer cask made from a copper/nickel alloy (instead of stainless steel) and polyethylene. This material is recommended for the 3.0 m cask as well. The cost increase is because additional material is needed to lengthen the cask 1.5 m.
- Fabricate one less impact absorber per storage tube.
- Design and fabricate a larger capacity transportation trailer for the casks and canisters. The cost increase reflects the base cost to increase the trailer capacity and materials and fabrication costs to extend the cask support frame that mounts on the trailer.
- Construct an overpack pit by deepening the No. 7 hot conditioning annex (HCA) pit 41 cm (16 in.) or build a new pit 1.5 m deeper.

Schedule Impact

The transportation upgrades and CSB modifications to implement the 3.0 m canister retrofit are expected to have no significant schedule impacts. However, the impact of the MHM modifications on the Spent Nuclear Fuel CSB Project mission will need to be assessed in the updated conceptual design activity. To validate Project W-464 in fiscal year 1998 (early validation) in accordance with the TWRS Multi-Year Work Plan¹ the baseline project documents will need to be updated by the end of calendar year 1997.

¹LMHC, 1997, *Tank Waste Remediation System Fiscal Year 1998 Work Plan- WBS 1.1*, HNF-SP-1230, Rev. 0, Lockheed Martin Hanford Corp., Richland, Washington.

TABLE OF CONTENTS

1.0 INTRODUCTION	1
1.1 BACKGROUND	1
1.2 STUDY SCOPE	1
1.2.1 Equipment Design, Fabrication, and Implementation	2
1.2.2 Cost	2
1.2.3 Studies	2
1.2.4 Study Assumptions	2
2.0 CSB SYSTEMS AND OPTIONS	3
2.1 MHM	3
2.1.1 MHM Body and Internal Cavity	3
2.1.2 MHM-Shielding	4
2.1.3 MHM Hoist	5
2.1.4 MHM Control System	5
2.2 HLW RECEIVING PITS	5
2.2.1 MCO Receiving Pit	5
2.2.2 FFTF Pit	6
2.3 TRANSPORTATION	6
2.3.1 HLW Transportation Cask	6
2.3.2 Transportation Trailer	7
2.3.3 Receiving Crane	7
2.4 PACKAGING SYSTEM	7
2.4.1 Overpack Station	7
2.4.2 Vault	8
2.4.3 Impact Absorbers	8
3.0 CONCLUSIONS AND RECOMMENDATIONS	9
3.1 MHM BODY	9
3.2 HLW TRANSPORTATION CASK	9
3.3 IMPACT ABSORBERS	9
3.4 TRANSPORTATION TRAILER	9
3.5 OVERPACK STATION	9
3.6 ADDITIONAL BENEFITS	10
4.0 RECOMMENDED SYSTEM STUDIES	10
5.0 COST	10
5.1 Project Documents	11
5.2 Capital Equipment	11
5.3 Engineering Studies	12
6.0 SUMMARY TABLE	12
7.0 REFERENCES	23

LIST OF FIGURES

1 4.5 Meter Canister and Cask	20
2 Transfer Pit Options	21
3 Pit Options With New Cask	22
4 HCSA Pit Modifications	23
5 Impact Absorbers	24
6 MHM	25

LIST OF TABLES

1 Receiving Crane Load Summary	7
2 Summary Table	13

LIST OF TERMS

ALARA	as low as reasonably achievable
CD	conceptual design
CFR	<i>Code of Federal Regulation</i>
CSB	Canister Storage Building
FFTF	Fast Flux Test Facility
FY	fiscal year
G&A	general and administrative
HCSA	Hot Conditioning System Annex
HLW	high-level waste
HWVP	Hanford [HLW] Waste Vitrification Project
LLW	low-level waste
IS	Interim storage
MCO	multi-canister overpack
MHM	material handling machine
MPR	material procurement rates
SESC	SGN Eurisys Services Corporation
SNF	spent nuclear fuel
TWRS	Tank Waste Remediation System
VROM	very rough order of magnitude
WAC	<i>Washington Administrative Code</i>
WVDP	West Valley Demonstration Project

1.0 INTRODUCTION

1.1 BACKGROUND

The Tank Waste Remediation System (TWRS) Storage and Disposal Project has established the Immobilized High-Level Waste (IHLW) Storage Sub-Project to provide the onsite capability to transport and interim store IHLW (vitreous glass product) generated during Phase I until it can be shipped to a federal geologic repository. The Sub-Project established a design/construction project, Project W-464, to retrofit the Hanford Site Canister Storage Building (CSB) to accommodate the Phase I IHLW product. Currently the CSB is being designed to accommodate interim storage of spent nuclear fuel (SNF) in one of three storage vaults under the established Hanford Site Project No. W-379. Project W-464 scope (i.e., CSB retrofits and new equipment installations) includes integration with Project W-379 mission and requirements.

The Project W-464 technical baseline includes requirements necessary to transport, receive, and store 3.0 m-long IHLW canisters. In accordance with the Phase 1A Contract (DOE-RL 1996a and 1996b), DOE is considering replacing the 3.0 m (9-ft 10-in.) IHLW Product canister with a canister 4.5 m (14-ft 9-in.) long with the same diameter. DOE believes that using the 4.5 m canister will significantly reduce permanent disposal costs. This study was conducted to identify potential key impacts to Project W-464 cost and schedule caused by including the 4.5 m canister in the Project W-464 baseline.

Before the Project W-464 conceptual design (CD) activity began, preconceptual engineering studies (Jacobs 1996a and 1996b) were performed to evaluate the viability of retrofitting the CSB to accommodate Phase I IHLW product. These studies included an assessment of 4.5 m canisters. Much of this study is based on the design concept development and associated cost estimates from the Jacobs assessment. However, some of these concepts required further evaluation based on current SNF CSB design status. For example, the preconceptual engineering evaluation was performed for a MHM design that ultimately was not the design selected by the SNF CSB Project (Project W-379).

The Project W-464 conceptual design activity was started in February 1997. At the end of fiscal year (FY) 1997, Project W-464 CD activities, including design of the 3.0 m-long IHLW canister, will be approximately 60 percent complete. The 60-percent CD includes the bulk of technical work scope; the remaining work is primarily cost estimation, safety evaluations, and CD report (CDR) preparation.

1.2 STUDY SCOPE

This study will address the effects to the Project W-464 baseline cost and schedule of using the 4.5 m HLW canister instead of the 3.0 m HLW canister. The study will evaluate the preconceptual engineering studies for equipment options, research the SNF proposed and existing equipment for HLW equipment options, select the best available option or develop new options, and provide recommendations and an implementation path forward. The cost of the 4.5 m canister equipment recommendations will be compared to the baseline 3.0 m canister option to determine the cost impact. The impact (primarily cost) to the following Project W-464 activities will be assessed:

- Baseline document revisions
- Conceptual design and CDR preparation

- Detailed design
- Capital equipment cost and implementation
- Required future engineering studies.

1.2.1 Equipment Design, Fabrication, and Implementation

All the equipment that will be used to store the IHLW canisters and transport and handle them from the unloading station at the IHLW vitrification facility to the CSB storage vaults and other CSB handling stations will be evaluated. The equipment modifications for the 4.5 m canister will be compared to the baseline modifications being proposed in the Project W-464 conceptual design activity to determine cost impacts. The cost estimates for the 4.5 m canister options will include costs to design, fabricate, and implement the retrofits.

1.2.2 Cost

A preliminary very-rough-order-of-magnitude (VROM) cost estimate summary will be provided. The summary will indicate the cost impacts to design, fabricate, and implement the changes to the equipment to accommodate the 4.5 m HLW canisters. Preliminary VROM cost estimates also will be provided so baseline documents can be revised and the engineering studies needed to include the 4.5 m canister in the Project W-464 baseline can be performed.

1.2.3 Studies

This study will determine the feasibility and VROM cost and schedule impacts of using 4.5 m HLW canisters. To further assess the impacts and validate the recommendations, more specific studies will be required. These studies are identified in this document.

1.2.4 Study Assumptions

The following assumptions were used during this study:

- The IHLW Storage Sub-Project includes overpack capability for Phase 1 canisters
- The onsite shipping cask is designed for the 4.5 m canister only (overpack not considered)
- The West Valley Demonstration Project (WVDP) canister nozzle design is used for 4.5 m canister and overpack designs.
- The decision to incorporate the 4.5 m canister in Project W-464 baseline will be made by October 1, 1997, to support April 1998 Project validation.

2.0 CSB SYSTEMS AND OPTIONS

The preconceptual engineering studies and available SNF CSB design were evaluated to determine key transportation and CSB systems that could be significantly affected by adding the 4.5 m IHLW canister to the Project W-464 baseline. The following systems were selected for evaluation:

- MHM
- HLW receiving pits
- Onsite transport cask
- Onsite transport trailer and supporting systems
- Receiving crane
- Overpack station
- Storage vault tubes and impact absorbers.

Options to incorporate the 4.5 m IHLW canister were evaluated for each system and are discussed in this section. In addition, this section covers studies that would be required to resolve potentially significant issues associated with each option. The recommended options are provided in Chapter 3.0, "Conclusions and Recommendations."

2.1 MHM

The multiccanister overpack handling machine (MHM) is being designed by Foster Wheeler to handle the SNF multiccanister overpack (MCO) canisters, primarily in Vault 1 of the CSB. The design was reviewed and discussed with Foster Wheeler to develop and evaluate the selected options and to confirm estimated costs. Because the MHM is still being designed, no specific engineering studies were performed for this system; therefore these options may need to be reevaluated once the MHM design is complete.

2.1.1 MHM Body and Internal Cavity

The MHM body is the storage and shielding vessel for the IHLW canister during transport from the receiving pit to all other building handling stations. The body has a internal diameter of 69 cm (27 in.) and an internal cavity length capable of handling a 432 cm (170-in.)-long canister (length of overpacked MCO). The 4.5 m HLW canister is approximately 178 in. long and a overpacked 4.5 m canister will be a approximately 4.8 m (188 in.) long. (See Figure 1.) The following two options for accommodating the overpacked 4.5 m canisters were evaluated.

- Reduce the length of the grapple assembly by approximately 51 cm (20 in.). This would allow the longer overpacked 4.5 m canisters to be handled using the existing MHM body.

Foster Wheeler will design the MHM to allow replacement of the grapple. However, the replacement operation is expected to be time consuming and should be performed infrequently. The only cost impact considered is the additional costs to design and fabricate a shortened grapple to allow the 4.5 m overpacked canister to fit in the MHM body. The amount that the grapple can be shortened is expected to be limiting, thus overpack canisters longer than 4.8 m (188-in.) would make this option difficult to implement.

- Lengthen the body of the MHM approximately 51 cm (20 in.). This will add approximately 4536 kg (10,000 lb) to the MHM. If the MHM is designed to handle only the IHLW canisters, this would not be a concern because the MCO is 5216 kg (11,500 lb) heavier than the 4.5 m canister. The overall weight change would be a reduction of approximately 680 kg (1,500 lb). However, the MHM probably will be required to be able to handle the MCOs and the IHLW canisters. This would result in a weight increase of 4536 kg (10,000 lb) on the bridge crane portion of the MHM assembly over the SNF design, which is the current MHM body handling a full MCO.

A MHM bridge and CSB floor structural analysis will be required to determine if the extra weight will require further modifications or possible replacement of the bridge, MHM, or both. The extra length of the MHM could also result in the top of the MHM interfering with the west wall building cross bracing. When the final MHM drawings are released, tolerances need to be compared to verify that no interferences exist. A cursory review of the latest Foster Wheeler MHM drawings and cross braces indicate that the MHM could be raised the required height. If interferences do exist, administrative controls, collision avoidance systems, or bridge modification options will need to be evaluated to devise an effective solution.

2.1.2 MHM-Shielding

The MHM radiation design requirement is to provide an MHM design that limits personal radiation exposure to less than 0.5 mrem/h at 30 cm. To compensate for the greater isotopic source strength of the IHLW canisters over a MCO, the following two shielding options have been considered. One of these options needs to be implemented for whichever canister size is used.

- Add 2.54 cm (1 in.) of steel around the MHM cask body from the bottom to a height of 24.3 m (96 in.). This will increase the MHM weight by approximately 2812 kg (6,200 lb). The additional weight does not affect the MHM when using the 3.0 m HLW canister because the MHM is designed for an MCO, which is approximately 6577 kg (14,500 lb) heavier. However, if the additional shielding weight is considered along with the additional weight of a longer MHM body, the weight increase will be 7348 kg (16,200 lb). If the MHM must handle both IHLW canisters and MCOs, a structural analysis is required to ensure that the MHM can safely handle the additional weight.

According to Foster Wheeler, the MHM design capacity is currently limited by the girders on the MHM bridge. Therefore, it will not be possible to confirm the viability of this option without performing a structural analysis of the MHM with this significant load increase. Modifications to the structural support up to and possibly including installation of a new MHM and bridge crane are expected to be needed. This shielding option may be viable if the MHM grapple is shortened to add internal MHM cavity length to accommodate the 4.5 m canister.

- Keeping personnel at least 30 cm (12 in.) from the MHM cask body surfaces will have the same effect as adding 2.54 cm (1 in.) of steel to the MHM body. Adding a guard around and to the top of the MHM cask body will limit the exposure of operations personnel to radiation to acceptable levels. The guard will add approximately 1225 kg (2,700 lb) to the MHM

weight. The combined weight of the guard and the weight to lengthen the MHM body to accommodate the 4.5 m canister is 5761 kg (12,700 lb). This is the weight increase to the MHM integrated system if it must handle both IHLW canisters and MCOs. A MHM bridge and CSB floor structural analysis will be required to determine if handling the extra weight will require modifications. Therefore, confirming the viability of this option is not possible without performing a structural analysis of the MHM with this increased load. Modifications to the structural support up to and possibly including installation of a new MHM and bridge crane are expected to be needed. This shielding option is viable if the MHM grapple is shortened to lengthen the internal MHM cavity to accommodate the 4.5 m canister. The complexity of the guard design may influence its cost and viability. A detailed evaluation of this type of design on the MHM body needs to be performed because of the difficulty associated with attaching this type of structure to the MHM body using the existing design for the support equipment and access panels.

2.1.3 MHM Hoist

The MCO payload is approximately 8618 kg (19,000 lb). The HLW 4.5 m canisters payload is approximately 3402 kg (7,500 lb). The MHM hoist system is being designed to handle the heavier MCOs and so will have no trouble with either HLW canister. However, if the MHM's body is lengthened to accept the 4.5 m canister, the hoist will be raised and its cable may have to be lengthened so that it can be used to install the bottom storage tube impact absorber.

2.1.4 MHM Control System

The present MHM control system is set up to handle the MCO's length and weight, as well as its impact absorbers. The limit switches, load cells, and logic circuits on the control system would have to be modified to accept the new configurations of the HLW canister and impact absorbers. These modifications would need to be made for either the 3 m or 4.5 m canisters.

2.2 HLW RECEIVING PITS

The receiving pits will be the interim receipt and transfer location of the HLW canisters. The onsite shipping cask will be delivered to the selected receipt pit and the cask lid will be removed by a mobile 9072 kg (10-ton) gantry crane. The canisters will be removed from the cask and transported within the CSB by the MHM. Two pits already located in the CSB receiving bay, the MCO pit and the Fast Flux Test Facility (FFTF) pit, are considered options for receiving and transferring HLW canisters. The MCO pit is designed to handle SNF MCOs. The FFTF pit is designed to handle FFTF SNF packages. (See Figure 2.)

2.2.1 MCO Receiving Pit

The MCO receiving pit is 566 cm (223 in.) deep and 142 cm (56 in.) in diameter. A shielded onsite transport cask designed with steel shielding (gamma) to accommodate the 4.5 m canister would need to be approximately 536 cm (211 in.) long with a 147 cm (58 in.) outside diameter. To use the MCO pit, the cask will need to be made with a less standard shielding material such as a copper-nickel alloy to reduce the

diameter to 137 cm (54 in.) with the same shielding capabilities. This modification would be required for either canister. Using the MCO pit for the 4.5 m canister/cask will allow only 30 cm (12 in.) or less to accommodate an impact absorber. An engineering analysis of the HLW pit impact requirements (canister drop) and potential impact absorber designs is required before the viability of this option can be confirmed.

The SNF CSB (Project W-379) design includes a 25.4 cm (10-in.)-thick shield hatch assembly for the existing MCO transfer pit. A track-mounted 4536 kg (5-ton) gantry crane is being provided to install and remove the assembly during MCO transfer operations. The HLW canisters will require a 46 cm (18-in.) thick shield hatch assembly to meet shielding requirements for as low as reasonably achievable (ALARA) guidelines. A 9072 kg (10-ton) gantry crane will be required to handle this larger assembly.

2.2.2 FFTF Pit

The FFTF pit is 4 m (12 ft) square and 6 m (20 ft) deep. This pit is large enough to handle the 4.5 m canister with adequate room for an impact absorber. To accommodate the 4.5 m canister, side guides, a bottom pedestal, and shielding hatches will need to be added to the FFTF pit. These features are required for either length IHLW canister.

If the FFTF Pit is used, a larger shield cover than envisioned for the MCO pit would have to be fabricated to cover the 4 m (12-ft)-square opening.

2.3 TRANSPORTATION

The transportation system includes the following equipment: HLW onsite shielded transportation cask, transportation trailer, and receiving crane.

2.3.1 HLW Transportation Cask

Several options are available for transportation casks. These depend primarily on canister size and transfer pit selection. Two options were evaluated specifically for the 4.5 m canister.¹

The first option is to build a new cask for the 4.5 m HLW canisters using standard materials. The May 1996 preconceptual engineering study concluded that a cask wall 41 cm (16 in.) thick would be required to provide adequate shielding for the HLW canisters. The wall would be composed of 28 cm (11 in.) of steel, 10 cm (4 in.) of borated polyethylene (neutron), and a 2.54 cm (1-in.) stainless steel shell. This would result in a cask with a diameter of at least 147 cm (58 in.), which could be used only in the FFTF pit. Because of the extra 1.5 m length of the 4.5 m canister, material and fabrication costs would be higher than for the cask designed for the 3.0 m canister.

¹For both options, drop testing and structural analysis will be required for both cask designs accommodating either a 3.0 and 4.5 m canister because new casks must be designed for both canisters. Therefore, no additional costs impacts are expected for designing the 4.5 m cask.

The second option is to make a smaller diameter cask with equivalent shielding using a copper-nickel alloy (gamma) and polyethylene (neutron) design. Decreasing the diameter from 147 cm to 137 cm (58 to 54 in.) will make it usable in the MCO pit. (See Figure 3.) No additional cask design costs are expected over those incurred to design casks for a 3.0 m canister.

For both options, the cost impact is the cost of additional materials required to provide for the longer 4.5 m cask.

2.3.2 Transportation Trailer

The 4.5 m canister and cask weigh approximately 44452 kg (98,000 lb or 50 tons). The 3.0 m canister and cask weigh approximately 29484 kg (65,000 lb or 33 tons). The heavier 4.5 m canister payload will require a larger transportation trailer. Because the 3.0 or 4.5 m casks and canisters weigh too much for the existing MCO trailer capacity [27216 kg (30 tons)], a new trailer will need to be designed and fabricated. The difference in weight between the 3.0 and 4.5 m casks and canisters is approximately 15422 kg (17 tons) and would require a 45360 kg (50-ton) base trailer instead of a 36288 kg (40-ton) base trailer.

2.3.3 Receiving Crane

The CSB receiving crane has a rated capacity of 54432 kg (60 tons). The rated capacity is adequate for lifting any of the HLW canisters and casks discussed in this report. However, a seismic analysis will be required to verify that the acceptable design lifting capacity is not significantly below the rated capacity. Table 1 summarizes payload weights of the packages considered in this report.

Table 1. Receiving Crane Load Summary.

Item Lifted	Payload Weight [kg (lb)]	Cask Weight [kg (lb)]	Total Weight [kg (lb)]
3 m HLW canister/new cask	2100 (4,631)	27216 (60,000)	29317 (64,631)
4.5 m HLW canister/new cask (Cu/Ni)	3402 (7,501)	40779 (89,900)	44181 (97,401)
4.5 m HLW overpack/new cask	4180 (9,216)	40779 (89,900)	44959 (99,116)
MCO/MCO cask	8618 (19,000)	18144 (40,000)	26762 (59,000)

2.4 PACKAGING SYSTEM

The packaging system includes the overpack station, storage vaults (Vaults 2 and 3), storage tubes, and impact limiters.

2.4.1 Overpack Station

The capability to overpack an IHLW canister is included in the Project W-464 baseline design requirements and will be required for a 4.5 m canister. The options for providing the 4.5 m canister overpack are to renovate Hot Conditioning Annex (HCA) Pit No. 7 or build a new overpack pit in the HCA.

The internal diameter of HCA Pit No. 7 is adequate and should provide the proper clearance to perform HLW overpacking operations. The overall dimensions of Pit No. 7 are 122 cm (48 in.) diameter by 640 cm (252 in.) deep with a 30 cm (10-ft) square by 126 cm (51-in.) deep recessed cavity at the top. (See Figure 4.) The available depth in which to conduct overpacking operations in HCA Pit No. 7 is 599 cm (236 in.). The pit is not deep enough to accommodate the 640 cm (252 in.) needed for the 4.5 m canister overpack operation. To use HCA Pit No. 7 for the 4.5 m canister overpack operation, it would need to be lengthened 41 cm (16 in.). Adding 41 cm (16 in.) requires excavating the pit and pouring a reinforced concrete foundation.

The second option, constructing a new HLW overpack pit that could accommodate the 4.5 m canister overpack operation, would only be done if a constructability assessment of Pit No. 7 shows that modifying it is technically challenging and/or costly.² Therefore, only deepening HCA Pit No. 7 1.5 m to accommodate a 4.5 m canister instead of a 3.0 m canister will be included in the cost impact assessment.

If it were built, the new pit would be located in the southeast corner of the CSB HCA operating area. Building a new pit is expected to require a significant structural integrity assessment of the deck and supporting structural features.

2.4.2 Vault

As part of the preconceptual engineering studies, the IHLW canister source term was used to develop the highest possible canister centerline temperature. The evaluation included three 3.0 m canisters, each with the maximum allowable radioisotopic content, placed in a CSB tube. The IHLW temperature was determined to be much lower than the allowable maximum temperature of 400 °C (752 °F). Therefore, using the 4.5 m canisters is not expected to require additional vault/tube modifications.

2.4.3 Impact Absorbers

Each tube will require only two impact absorbers when the tube is filled with 4.5 m canisters. One impact limiter is needed in the bottom of the tube and one is needed between the two canisters. Three impact limiters are required when placing three 3.0 m canisters in a storage tube; one on the bottom and one between every two canisters. The impact limiters for the 4.5 m canister will need to be designed to take a larger dynamic load in the case of an accidental drop than those for the 3.0 m canister. The design and implementation of a heavier duty impact limiter is not expected to cause any significant cost increase over that required for a 3.0 m canister.

²A constructability study will be needed to resolve the identified issues associated with new pit construction and with recessing HCS Pit No. 7 before making an implementation decision.

3.0 CONCLUSIONS AND RECOMMENDATIONS

3.1 MHM BODY

Recommending one option to accommodate the increased length of the 4.5 m canister in the MHM is *not considered practical* without further information and analysis. Therefore, both options will be included in the cost impact assessment.

The option to increase the MHM body is fairly straightforward; however, the significant weight increase associated with this option, coupled with the weight from either shielding option (add 1-in steel or guard restriction), would require an extensive structural analysis of the MHM integrated system. The structural analysis could uncover the need to perform costly upgrades or replace the MHM, the bridge, or both. The cost impact assessment will consider the case where the structural analysis shows that no structural modifications are necessary (cost of analysis only) and the worst case scenario (replacement of the MHM).

The option to shorten the grapple probably is compatible with both shielding options, given the MHM weight limits. Adopting this option will require that a scoping study be done to determine if the required 46 cm (18-in.) length reduction of the grapple is viable and if the slight weight increase caused by the shielding associated with this option is acceptable. The cost impact assessment will include the cost to perform a viability analysis (technical and operational) and the cost for fabricating a new grapple.

3.2 HLW TRANSPORTATION CASK

The copper-nickel (Cu/Ni) alloy cask is recommended for use with the 4.5 m canister in accordance with the results of preconceptual engineering studies and conceptual design activity recommendations. The cost difference is expected to be the cost of the materials required to lengthen the cask for the 4.5 m canister.

3.3 IMPACT ABSORBERS

The cost reduction associated with using one less impact absorber per tube for the 4.5 m canister will be reflected in the cost estimate. This estimate will not account for marginal material cost differences between the impact limiters for the 4.5 m and 3.0 m canisters.

3.4 TRANSPORTATION TRAILER

A new transportation trailer will be required to transport either the 3.0 or the 4.5 m canister/cask load. The cost difference between a trailer needed for a 3.0 canister and 4.5 canister, as well as the material and fabrication cost to make a larger cask holder, will be included in the cost impact assessment.

3.5 OVERPACK STATION

Both options are included in the impact assessment: the cost to renovate HCA Pit No. 7 and the cost to add 1.5 m of depth to a new pit.

3.6 ADDITIONAL BENEFITS

Use of the 4.5 m canister will reduce the number of transfers (both canisters and impact absorbers) in the building and reduce personnel exposure by approximately 30 percent over the life of the facility. No cost benefit will be assigned to this reduction.

4.0 RECOMMENDED SYSTEM STUDIES

The recommended modifications are based on the information provided from existing studies. Further studies will be required to validate the costs and recommendations. The recommended studies are as follows:

- Perform engineering analysis and tolerance stack up on grapple and MHM body modifications to verify that 4.5 meter canisters can be fit inside the MHM body. Perform engineering tolerance stack up of the structural interferences with the MHM and the building supports if the MHM is lengthened.
- Perform structural analysis of MHM bridge and CSB floor to determine the extent of modification, if any, needed to accommodate a heavier MHM that meets safety and functional requirements.
- Perform thermal analysis on the MHM body and proposed HLW cask designs to verify that the 4.5 m canisters can be handled safely and are within constraints for Code and cask outer temperature.
- Evaluate impact absorber requirements for tubes and HLW receiving and overpack pits to determine type and size of impact absorbers required and if pits options can accommodate them.
- Review receiving crane HLW seismic requirements to verify that no upgrade modifications will be needed to the crane.
- Verify constructability of using the HCA Pit No. 7 pit as a overpack pit and the constructability of building a new overpack pit.

5.0 COST

Adding the 4.5 m canister to the Project W-464 baseline results in an estimated project cost change ranging from a reduction of \$425k to an increase of \$4,525k.

The cost estimates provided in this section are very-rough-order-of-magnitude (VROM) estimates. The estimates include both direct and indirect costs associated with modifications and engineering activities identified in the recommendations. Engineering costs associated with design activities or engineering studies are based on an average rate of \$75/engineering labor hour. Because the cost estimates are at the VROM level, no material procurement rates (MPR), general and administrative (G&A) escalation, or contingency adders were considered.

In cases where no option is clearly superior, costs are provide for all options. In most cases, only the best and worst case cost estimate are provided for each option because further engineering studies that are out of scope in this study would be required to calculate an intermediate cost estimate.

The cost estimate reflects only the additional costs (cost incurred or saved) incurred if the 4.5 m canisters are used instead of the 3.0 m canisters. Estimated capital costs include design and implementation costs.

The cost estimate is based on consideration of the following: modification to project documents, update of conceptual design and conceptual design report, capital equipment design and implementation, and required technical engineering studies.

Specific estimated cost impacts are provided in Sections 5.1 through 5.3.

5.1 Project Documents

- Modify baseline Project documents (i.e., design requirements document and supplemental conceptual design statement of work and work plan); Estimated cost: \$50k
- Update transportation and CSB facility conceptual design; Estimated cost: \$200k
- Total estimated Project document cost: \$250k

5.2 Capital Equipment

Primary capital equipment modifications or additions and respective subtotal costs are as follows:

- Reconfigure internal MHM body and equipment (grapple) to allow for 4.5 m overpacked canister or lengthen the MHM body.

The best case scenario is that the grapple is analyzed and can be modified to accommodate the IHLW canister. Definitive design, fabrication, and installation is estimated to be \$200k. The cost to increase the MHM length is estimated at \$995k. The worst case scenario is that a new MHM bridge crane and modified MHM vessel are required. The cost estimate is \$5,000k to replace the MHM. The cost estimates for MHM modifications were based on Foster Wheeler Engineering input. Estimated cost: \$200k to \$5,000k

- Design and fabricate a longer cask made of copper/nickel alloy and polyethylene. The cost increase is because the cask is 1.5 m longer. The estimate for the increased cost is based on

escalating the cask cost estimate from the September 18, 1996 report by one-third because the cask is approximately one-third larger. Estimated cost: \$1,008k (for three casks)

- Fabricate one fewer impact absorber per storage tube, which results in 456 fewer impact absorbers needed. The cost estimate is based on to-date vendor response to provide MCO impact absorbers for Project W-379. Cost is \$6.4 k per storage tube. Estimated cost: \$-2,918 k (cost saving)
- Design and fabricate a larger capacity transportation trailer for the 4.5 m casks and canister. The cost estimate reflects the base cost to upgrade the trailer capacity and the materials and fabrication costs to extend the cask support frame that mounts on the trailer. The cost estimate for the trailer upgrades were based on vendor input and engineering judgement. Estimated cost: \$450k (for three trailers)
- The two options for providing overpack capability are modifying HCA Pit No. 7 by increasing its depth by 4.1 m (16 in.) (\$400k) and constructing a pit (\$250k for adding 1.5 m of depth). The cost estimate for the pit modification was based on CSB project cost estimators input. Estimated cost: \$250k to \$400k.
- Estimated total capital equipment cost: \$1,010k to \$3,940K

5.3 Engineering Studies

- Perform engineering analysis of grapple and tolerance stack-up of MHM body modifications to verify that 4.5 meter canisters will fit in the MHM body. Some modification to the body and other sections of the MHM will be evaluated in conjunction with the grapple viability analysis. In addition, evaluate engineering tolerance of the structural interferences with the MHM and the building supports if the MHM is lengthened. Estimated cost: \$55k
- Perform a structural analysis on MHM bridge and CSB floor to verify that the heavier MHM still meets seismic and safety requirements. Estimated cost: \$100k
- Perform thermal analysis on the MHM body and proposed HLW cask designs to verify the 4.5 meter canisters can be handled safely, are within code specifications, and meet IHLW canister temperature requirements. Estimated cost: \$60k
- Evaluate impact absorber requirements for storage tubes and HLW pits (receiving and overpack), determine type and size required and if pit options can accommodate required impact absorbers. Estimated cost: \$60k
- Review receiving crane HLW seismic requirements to verify that no crane or structural modifications are needed. Estimated cost: \$40k
- Verify constructability of using the HCA Pit No. 7 pit as a overpack pit as well as the constructability of building a new overpack pit. Estimated cost: \$20k
- Total estimated study costs: \$335K

6.0 SUMMARY TABLE

Table 2 summarizes the key results of this study. It is intended as a quick lookup tool for information that was presented in the body of the study.

In Table 2, the bolded items were included in the cost estimate. The other options were included in the table to reflect all the options considered.

Table 2. Summary Table.

Equipment	Reason for Modification	Equipment Modification	Issues with Modification	Cost/Basis
MHM Body	4.5 m canister is too long for existing MHM body. Worst case is the canister that has been overpacked. Assumption will be that the overpacked canister will be handled in the MHM body.	Option 1. Reconfigure internal MHM body and grapple to allow for 4.5 m overpacked canister. Option 2. Lengthen MHM body 51 cm (20 in.)	Not clear enough room exists for redesign. Need to perform engineering analysis and design Adds 4536 kg (10,000 lb) to MHM, which will require redoing bridge crane and floor structural analysis. Analysis will be performed assuming MHM must handle MCO. Lengthening MHM could require some rework of trolley because of possible interference with building upper cross bracing. Tolerance stack up required.	\$200k/Foster Wheeler VROM \$995k to lengthen MHM/ Ref. CSB HLW supplemental report 9/18/96 or \$5,000k to replace MHM bridge and modify MHM vessel/ Discussion with MHM vendor NA/ Not expected to be significant issue based on preliminary review
MHM Shielding	The HLW canisters require more shielding than the MCOs in the MHM.	Option 1. Add 2.5 cm (1 in.) of steel to the outside of the MHM Option 2. Install 30 cm (12-in.) guard around the MHM body to get equivalent shielding effect for operators.	Adds 2812 kg (6,200 lb) to the MHM Adds 1225 kg (2,700 lb) to the MHM	NA/Same for 4.5 m canister as for 3 m canister NA/Same for 4.5 m canisters as for 3 m canisters

Table 2. Summary Table.

Equipment	Reason for Modification	Equipment Modification	Issues with Modification	Cost/Basis
MHM Grapple	The pintal design for the MCO and HLW canisters are different	Redesign and fabricate new grapple.		NA/Same for 4.5 m canisters as for 3 m canisters
MHM Hoist	MCO payload is 8618 kg (19,000 lb) HLW 4.5 m canister is 3402 kg (7,501 lb) HLW 3 m canister is 2101 kg (4,631 lb) The hoist's cable length is set for the MCO. If the MHM's body is lengthened for the 4.5 m canister, the hoist's cable might need to be lengthened.	MHM hoist system is designed to handle the heavier MCOs and will have no trouble with either HLW canister. Option 1. Modify hoist. Option 2. Replace hoist.	When final MHM design is complete, review design for possible modifications. When final MHM design is complete, review design for hoist replacement.	NA/Same for 4.5 m canisters as for 3 m canisters NA/Not expected to be significant issue based on preliminary review NA/Not expected to be significant issue based on preliminary review
MHM Control System	The present MHM system is set up to handle MCO's length and weight.	Modify control system, limit switches, load cells and logic to accept the HLW canisters configuration		NA/Same for 4.5 m canisters as for 3 m canisters
MHM Body Thermal Analysis	The 4.5 m canisters generate more heat than the 3 m canisters inside the MHM body.	Preform thermal analysis. Thermal analysis may result in adding a cooling system or modifying the existing gas flow system to decrease the heat load inside the MHM.		NA/Thermal modifications to the MHM will be similar in design and cost for either length canister
MCO Receiving Pit	The MCO receiving pit is 566 cm (223 in.) deep with a 142 cm (56-in.) diameter. The standard 4.5 m cask will be about 536 cm (211 in.) long with a 147 cm (58-in.) diameter.	Use cask with alloy shielding. [Cask 137 cm 954-in. diameter]. Install 46 cm (18-in.) cover shielding cover plate.	There might not be adequate clearance to install a adequate impact absorber at the bottom of the pit [30 cm (12 in.)]. Study required.	NA/Same for 4.5 m canisters as for 3 m canisters

Table 2. Summary Table.

Equipment	Reason for Modification	Equipment Modification	Issues with Modification	Cost/Basis
FFTF Pit	The FFTF pit is 366 cm (12 ft) square by 610 cm (20 ft) deep.	Option 1. Use 28 cm (11-in.) steel 10 cm (4-in.) polyethylene base cask. [cask 147 cm (58-in.) diameter] Install guides and 46 cm (18-in.) cover plate. Option 2) Use MCO cask and shielding overpack. [Cask 173 cm (68-in.) diameter.] Install guides and 46 cm (18-in.) cover plate.		NA/Same for 4.5 m canisters as for 3 m canisters NA/Same for 4.5 m canisters as for 3 m canisters
Cask	The 4.5 m canisters will require a longer cask.	Option 1. Build a approx. 531 cm (209 in.)-long cask of copper/nickel alloy and polyethylene @ 137 cm (54 in.) diameter. Option 2. Build a approx. 536 cm (211-in.)-long cask of steel and polyethylene @ 147 cm (58 in.) diameter.	The cost increase is caused by material increases to lengthen the cask. The total cost to build a large cask is \$1,008k. Because the cask is one-third longer, the cost increase is \$336k. The cost increase is caused by the increased cask length to handle the 4.5 m canisters.	\$1,008k ≈ \$336k for 3 casks Ref. CSB HLW supplemental report. Sept 18, 1996 NA/Option 1 recommended approach ;Option 1 allows use of MCO pit
Cask Thermal Analysis	The 4.5 m canisters generate more heat than the 3 m canisters inside the cask. Built cask to 10 CFR 71, 49 CFR 71.43, and 49 CFR 71.51	Perform thermal and radiological analysis on selected cask to verify within specifications	Possible cask shielding or cooling modifications to cask because of extra product. Design and cost will be simpler for either length canister.	NA /Not expected to result in significant cost

Table 2. Summary Table.

Equipment	Reason for Modification	Equipment Modification	Issues with Modification	Cost/Basis
Impact Absorbers	<p>3 m canister payload 2101 kg (4,631 lb) 4.5 m canister payload 3402 kg (7,501 lb)</p> <p>Need larger impact absorbers for the larger canisters.</p>	Design and fabricate larger impact absorbers for receiving pit and storage tubes.	<p>MCO receiving pit is 566 cm (223 in.) deep the standard cask is 536 cm (211 in.) long which only leaves 30 cm (12 in.) for the impact absorber. For the 4.5 m canister cask, the MCO pit may not be deep enough for a adequate impact absorber.</p> <p>Fewer impact absorbers will be needed in the storage tubes because each tube will contain two canisters instead of three.</p>	<p>NA</p> <p>S-2918k Based on \$6.4K per tube; 456 tubes Ref. CSB HLW supplemental report. Sept 18, 1996 Ref. MCO impact Absorbers vendor responses to RFP</p>
Transport Trailer	The 4.5 m canister and cask weigh 44181 kg (97,401 lb) The 3 m canister and cask weigh 29312 kg (64,631 lb). Heavier payload will require larger trailer capacity.	Because the 3 m cask and canister are too heavy for the MCO trailer capacity [27216 kg (30 tons)], a new trailer will need to be designed. The difference in weight is approx. 14515 kg (16 tons).	The cost reflects the difference in a standard 36288 kg (40-ton) to 45360 kg (50-ton) trailer and the materials to build a larger cask stand.	\$450k / Trailer vendor estimate is 150k per trailer x 3 trailers
Receiving Crane	The 4.5 m canister and cask weigh 44181 kg (97,401 lb) The 3 m canister and cask weigh 29312 kg (64,631 lb). Heavier cask payload requires larger crane capacity.	The existing receiving crane is rated for 54432 kg (60 tons), which should be sufficient to lift the 4.5 m canister and cask. However, a seismic analysis with specific HLW requirements will be required	Seismic analysis may require crane upgrades.	NA /This would probably be required for either the 3 m or 4.5 m canister casks.

Table 2. Summary Table.

Equipment	Reason for Modification	Equipment Modification	Issues with Modification	Cost/Basis
HCSA Pit Overpack Station	Use the No. 7 HCSA for a 4.5 m overpack station will require a depth of 640 cm (252 in.). The present HCSA pit is 599 cm (236 in.).	Option 1. Modify the No.7 HCSA pit by deepening it to 640 cm (252 in.) [41 cm (16 in.)]. For either canister, this pit option would require making a recessed cavity at the top.	The costs reflect the engineering and construction of lowering the pit to accommodate the 4.5 m canisters..	\$400k/ Discussions with SNF Construction Manager (James Mortimer)
		Option 2. Construct a new overpack pit that could accommodate the 4.5 m canisters.	The costs reflect the engineering and construction to lower the new pits depth enough to accommodate the 4.5 m canisters.	\$250k/ Discussions with SNF Construction Manager (James Mortimer)
Vault	The longer canisters could produce higher vault temperature that could exceed the maximum allowable of 400 °C (752 °F).	A study documented in the CSB HLW implementation study (Appendix B), concluded the highest canister centerline temperature could only be 248 °C (478 °F)		NA/Not expected

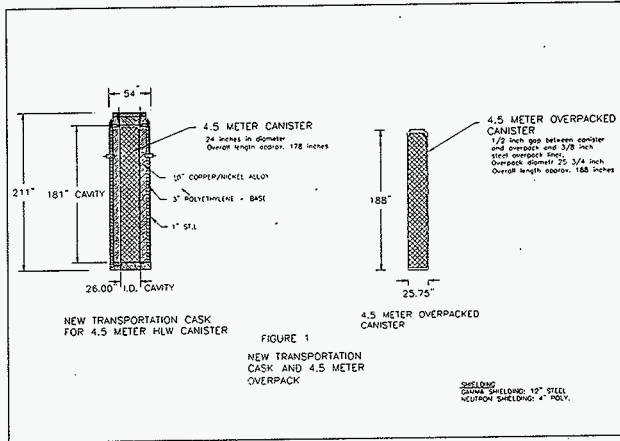

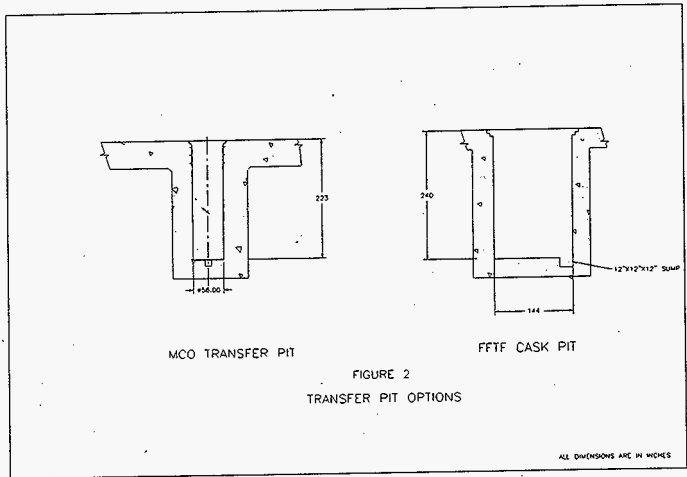

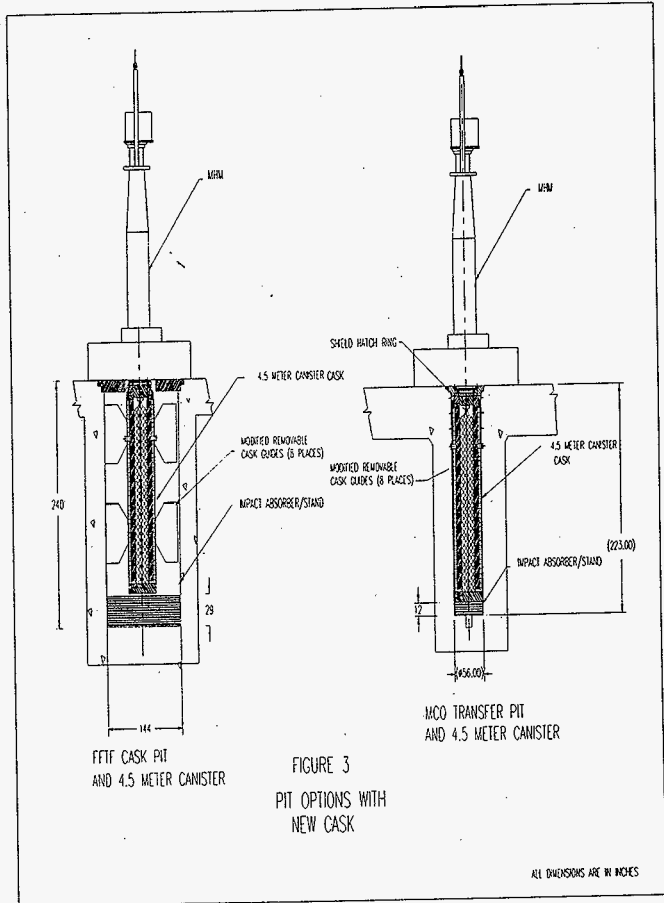

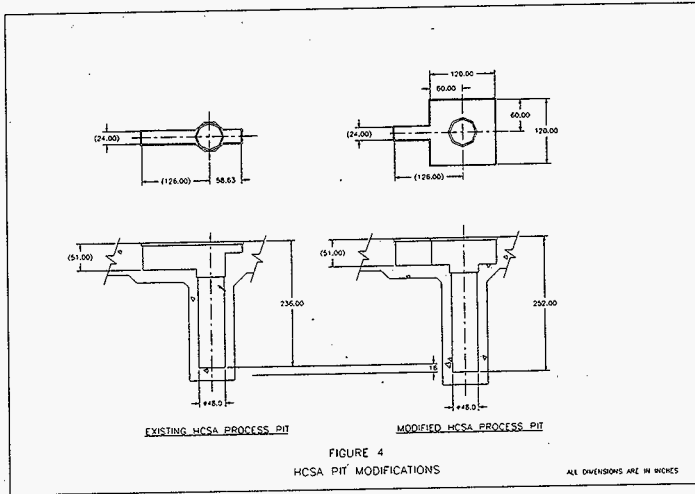

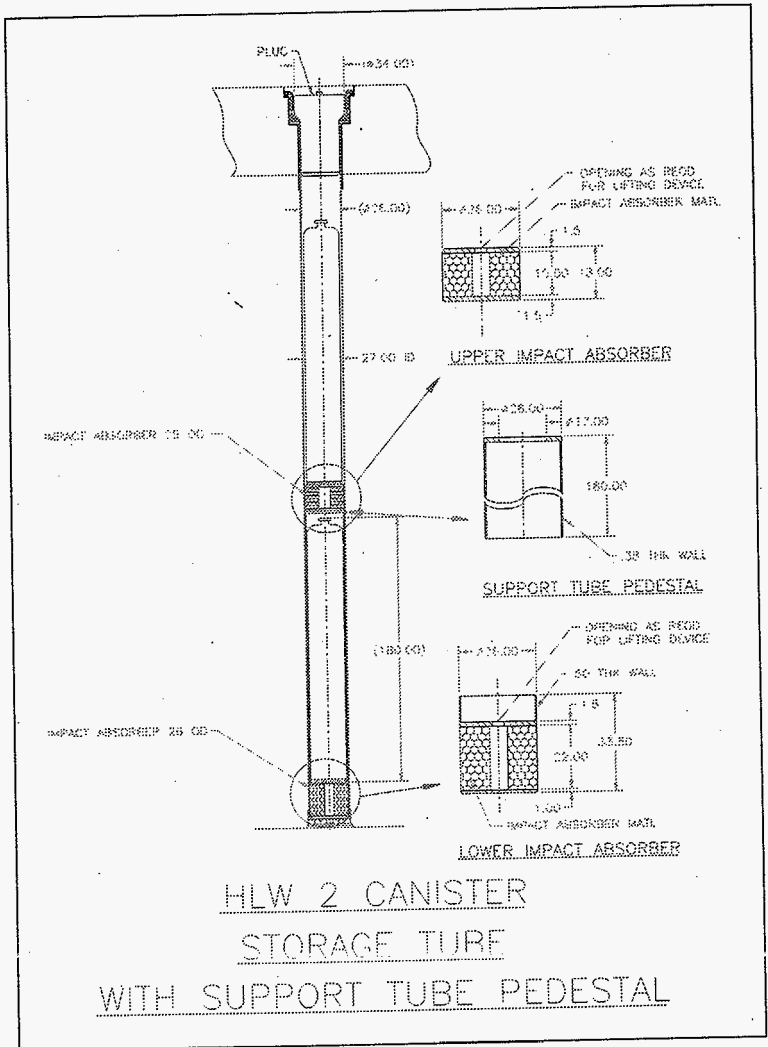

Figure 5. Straight Tube with Support Pedestals, Large Canisters.

7.0 REFERENCES

- Jacobs, E. R., 1996a, *Canister Storage Building (CSB) High-Level Waste (HLW) Implementation Study*, letter to J. J. Jones, Westinghouse Hanford Company, WHC P.O. TAA-SBW-400584, Fluor Contract 80455300, Correspondence No. FRF-034 dated May 13, 1996, Fluor Daniel Inc., Irvine, CA.
- Jacobs, E. R., 1996b, *Final CSB High-Level Waste Supplemental Report*, letter to J. J. Jones, Westinghouse Hanford Company, WHC P.O. TAA-SBW-400584, Fluor Contract 80455300, Correspondence No. FRF049 dated September 19, 1996, Fluor Daniel Inc., Irvine, CA.
- RL, 1996a, TWRS Privatization Contract No. DE-RP06-96RL13308 with British Nuclear Fuels Ltd., U.S. Department of Energy, Richland Operations Office, Richland, Washington.
- RL, 1996b, TWRS Privatization Contract No. DE-RP06-96RL13309 with Lockheed Martin Advanced Environmental Systems, U.S. Department of Energy, Richland Operations Office, Richland, Washington.

This page intentionally left blank.