

# Institutional Plan

FY 1995-2000

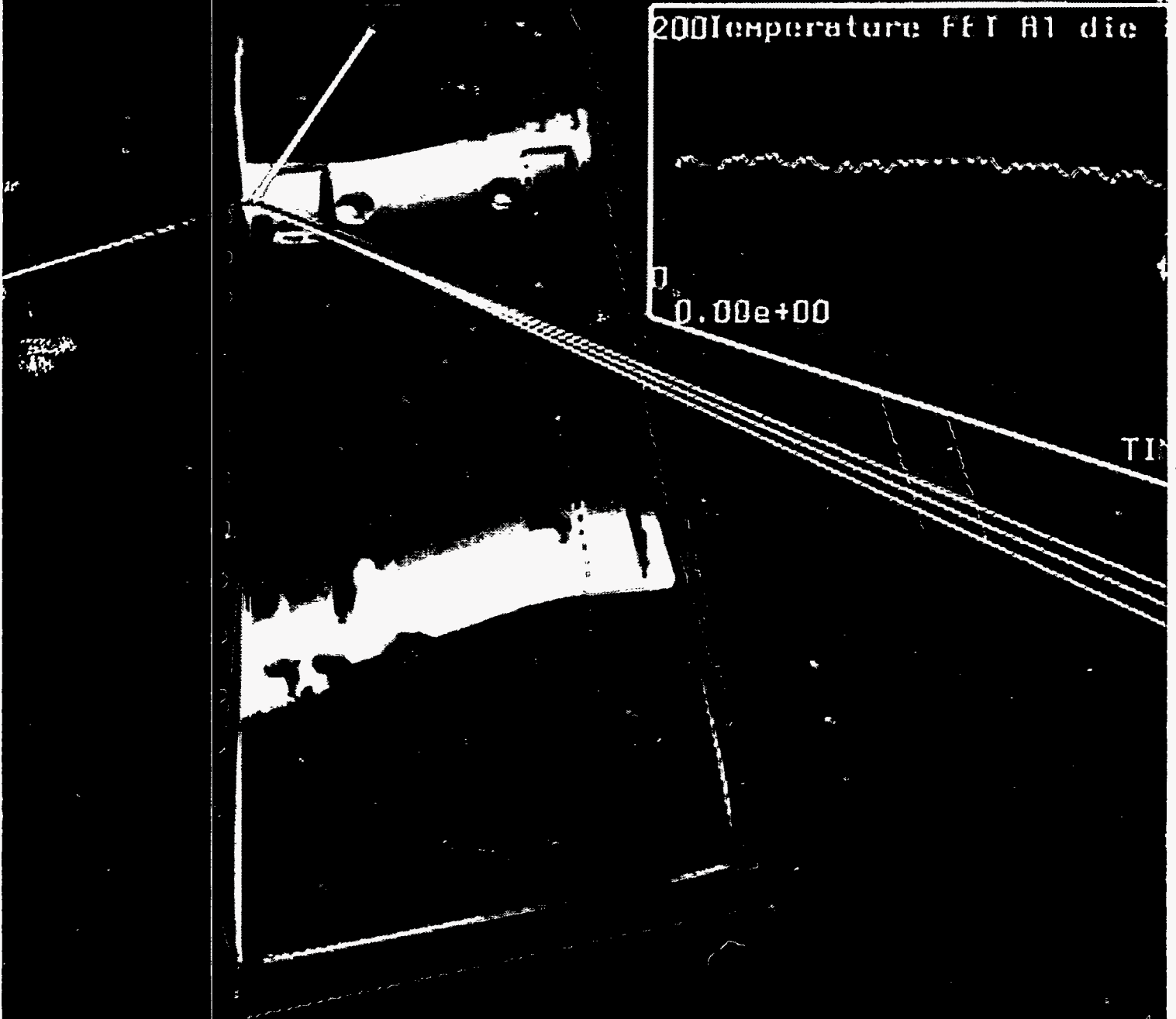

"...exceptional service in the national interest."

Director of Strategic and Operational Planning  
Manager of Institutional Planning

Joel Weis  
Bruce Da

Team Leader  
Senior Technical Writer/Editor  
Technical Indexer

Dan Garb  
Tim Peterson, TI  
Carol Crawford, TI

Cover, Design, Illustrations, Layout and Production

Arnold Puentes, TI

Photographs were contributed by Janet Carpenter, Irene Dubicka, Cynthia Figueroa-McInteer, Debra Johnson, Kent Meeks, Randy Montoya, Paul McWhorter, Mark Phillips, Mark Poulsen, Camille Reyes, John Vitko, and Louis Weichman.

### *About the Cover*

The cover shows an electronic component being designed and analyzed in the virtual manufacturing environment created by Sandia's Multidimensional, User-Oriented Synthetic Environment (MuUSE) virtual reality system. The two sets of converging white lines are the edges of a virtual craft that extends the physical world into the computer-generated virtual reality world. The short white line shows the MuUSE virtual craft probing a transistor component in a multichip module to determine temperature and electrical output. The colors indicate thermal fields mapped into visual data for rapid interpretation. The temperature-versus-time output during operation is overlaid as a graph at the right, on the transparent wall of the virtual craft. In the actual system, some temperature variations are also mapped into sound.

MuUSE-based virtual reality enabled engineers to explore simultaneously the dynamic fusion of many simulations. They first called up a three-dimensional model in a commercial package and then overlaid a finite-element analysis program, a Sandia-generated thermal analysis program, and two electrical simulation programs. By varying thermal conductivity of the substrate and viewing all the resultant simulations immediately, designers had for the first time a holistic model as a guide.

The MuUSE system is becoming a viable commercial tool. Funding has been allocated for the first application package, the Virtual Interactive Environment Work Space (VIEWS), a collaborative, interactive virtual reality design system. More than five hundred individuals from industry, academia, and government have seen the MuUSE demonstrations locally since the inception of the Virtual Manufacturing and Synthetic Environment Laboratory in January 1994. By invitation, Sandia also presented demonstrations in Washington DC at a National Information Infrastructure conference and to senior personnel from the White House Science Office. The reaction from government, scientists, businesspersons, and the press (including *The Economist*) has been very enthusiastic.

MuUSE was developed by Creve Maples and Craig Peterson. VIEWS is being developed collaboratively by Maples and Arlan Andrew.

SAND94-1931

DOE Distribution Category UC700

## **DISCLAIMER**

**Portions of this document may be illegible in electronic image products. Images are produced from the best available original document.**

Sandia National Laboratories

# *Institutional Plan*

*FY 1995-2000*

Albuquerque, New Mexico  
Livermore, California

*October 1994*

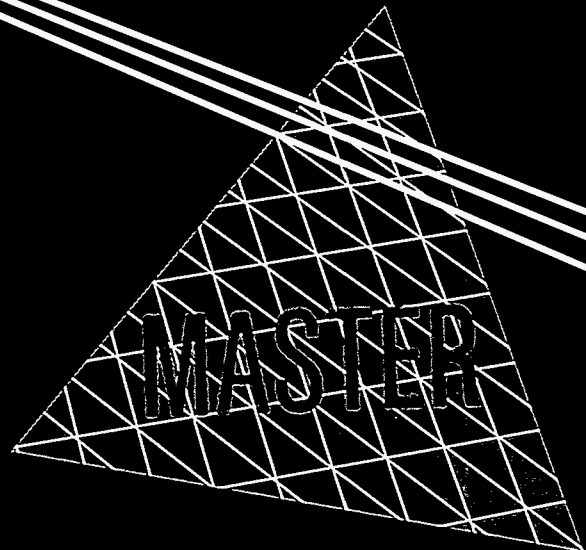

## DISCLAIMER

This report was prepared as an account of work sponsored by an agency of the United States Government. Neither the United States Government nor any agency thereof, nor any of their employees, makes any warranty, express or implied, or assumes any legal liability or responsibility for the accuracy, completeness, or usefulness of any information, apparatus, product, or process disclosed, or represents that its use would not infringe privately owned rights. Reference herein to any specific commercial product, process, or service by trade name, trademark, manufacturer, or otherwise does not necessarily constitute or imply its endorsement, recommendation, or favoring by the United States Government or any agency thereof. The views and opinions of authors expressed herein do not necessarily state or reflect those of the United States Government or any agency thereof.

*Strategic View*

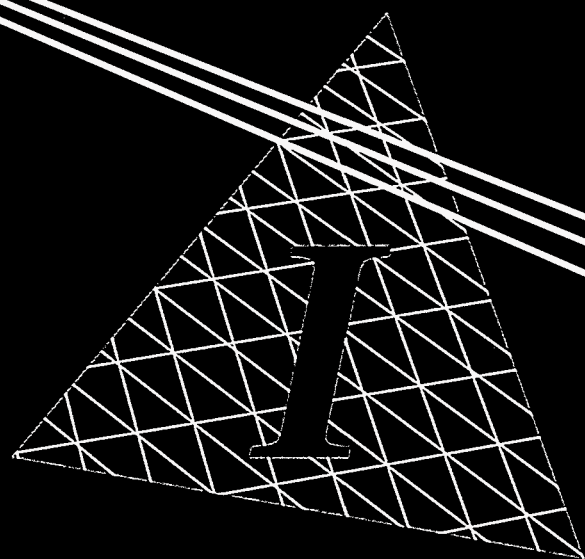

# Contents



## Strategic View

1 • A Message from Sandia's President and Laboratory Director, Al Narath .....	1-1
2 • Sandia National Laboratories Mission .....	2-1
Mission Focus .....	2-3
Established Program Responsibilities .....	2-3
Nuclear Weapon Programs .....	2-3
Energy and Environmental Programs .....	2-3
Work Other Than for DOE .....	2-3
Technology Transfer .....	2-3
Technology Responsibilities .....	2-4
Approach .....	2-4
Program Prioritization .....	2-4
Program Execution .....	2-5
3 • Laboratory Management Overview .....	3-1
Total Quality Management .....	3-1
Leadership .....	3-2
Information and Analysis .....	3-3
Strategic Quality Planning .....	3-3
Human Resource Development and Management .....	3-4
Management of Process Quality .....	3-4
Quality and Operational Results .....	3-5
Customer Focus and Satisfaction .....	3-5
Core Competencies .....	3-6
Research Foundations .....	3-6
Integrated Capabilities .....	3-6
Laboratory-Directed Research and Development Program .....	3-7
Facilities .....	3-8
Human Resources .....	3-9
4 • Laboratories Strategic Plan .....	4-1
Situation Analysis .....	4-1
Planning Assumptions .....	4-2
Defense .....	4-2
Energy and Environment .....	4-3
Technology .....	4-3
Economics .....	4-3
Politics and Society .....	4-3
Laboratory Operations .....	4-4
Strategic Objectives .....	4-4
Mission Objectives .....	4-4
Mission Success .....	4-4
Defense Programs .....	4-5
Energy and Environment .....	4-6
Work for Others .....	4-6
Core Competencies .....	4-7
US Industrial Competitiveness .....	4-8
Sandia Production Responsibilities .....	4-9
Operational Objectives .....	4-9
Quality .....	4-9
Business Management .....	4-10
People .....	4-10
Environment, Safety, and Health .....	4-11

V6

DISTRIBUTION OF THIS DOCUMENT IS UNLIMITED

5 • Major Initiatives .....	5-1
Advanced Manufacturing Technology .....	5-2
Electronics Technology .....	5-16
Advanced Information Technology .....	5-26
Transportation Energy Technology and Infrastructure .....	5-34
Environmental Technology .....	5-38
Energy Research and Technology Development .....	5-42
Biomedical Systems Engineering .....	5-51
Post-Cold War Defense Imperatives .....	5-53

## Programs

6 • Technology Transfer .....	6-1
Technology Transfer Program Strategy .....	6-2
Technology Transfer Thrusts .....	6-3
Research and Development Partnerships .....	6-3
Technology Deployment .....	6-8
Entrepreneurial Initiatives .....	6-9
Technology Transfer Achievements .....	6-10
7 • Research and Technology Development Programs .....	7-1
Programs for the Department of Energy .....	7-1
Weapons and Waste Cleanup Programs .....	7-1
Assistant Secretary for Defense Programs .....	7-4
Office of Nonproliferation and National Security .....	7-34
Office of Environmental Restoration and Waste Management .....	7-36
Energy Programs .....	7-40
Assistant Secretary for Energy Efficiency and Renewable Energy .....	7-40
Office of Civilian Radioactive Waste Management .....	7-42
Assistant Secretary for Fossil Energy .....	7-43
Office of Nuclear Energy .....	7-45
Science and Technology Programs .....	7-45
Office of Energy Research .....	7-46
Office of Science Education and Technical Information .....	7-53
Work for Other Department of Energy Locations, Contractors, and Offices .....	7-59
Work for Non-DOE Entities (Work for Others) .....	7-60
Department of Defense .....	7-60
Air Force .....	7-60
Navy .....	7-61
Army .....	7-62
Ballistic Missile Defense Organization .....	7-62
Defense Nuclear Agency .....	7-63
Advanced Research Projects Agency .....	7-64
Other Department of Defense .....	7-64
Nuclear Regulatory Commission .....	7-65
Department of Transportation .....	7-66
National Aeronautics and Space Administration .....	7-66
Department of State .....	7-67
Environmental Protection Agency .....	7-67
Other Federal Agencies .....	7-68
All Other Reimbursables .....	7-68





# Infrastructure & Support

<b>8 • Human Resources Management</b> .....	<b>8-1</b>
Laboratory Personnel .....	8-1
Human Resources Planning .....	8-1
Human Resources Programs .....	8-3
Equal Employment Opportunity/Affirmative Action and Diversity .....	8-5
Equal Employment Opportunity and Affirmative Action .....	8-5
Diversity Programs .....	8-6
<b>9 • Sites and Facilities</b> .....	<b>9-1</b>
Laboratory Description .....	9-1
Facilities Plans and Options .....	9-1
Site Development .....	9-1
Facilities Maintenance .....	9-6
Energy Management .....	9-6
Condition Assessment .....	9-6
General Purpose Facilities Plans .....	9-6
General Purpose Plant Requirements .....	9-6
General Purpose Equipment Requirements .....	9-7
Inactive Surplus Facilities Plan .....	9-7
Facilities Resource Requirements .....	9-7
Authorized Construction .....	9-7
Proposed Construction .....	9-9
<b>10 • Information Resources Management</b> .....	<b>10-1</b>
Information Resources Management Goals, Objectives, and Strategies .....	10-1
Information-Resources Environment .....	10-2
Computational Facilities .....	10-2
Telecommunications .....	10-4
Records Management .....	10-5
Management of Scientific and Technical Information .....	10-6
<b>11 • Environment, Safety, and Health Management</b> .....	<b>11-1</b>
ES&H Program Goals and Objectives .....	11-1
Regulatory Environment .....	11-2
Laws and Regulations .....	11-2
Sandia ES&H Requirements Documents .....	11-3
ES&H Policies, Organization, and Management .....	11-4
ES&H Plans and Initiatives .....	11-5
ES&H Work for the Office of Environmental Restoration and Waste Management (EM) .....	11-5
Core ES&H Programs .....	11-6
<b>12 • Security Management</b> .....	<b>12-1</b>
Program Overview .....	12-1
Protection Philosophy .....	12-1
Evolving Site Security Needs .....	12-2
The Changing Face of Security .....	12-3



# Appendix

<b>13 • Resource Projections</b> .....	<b>13-1</b>
Index .....	14-1

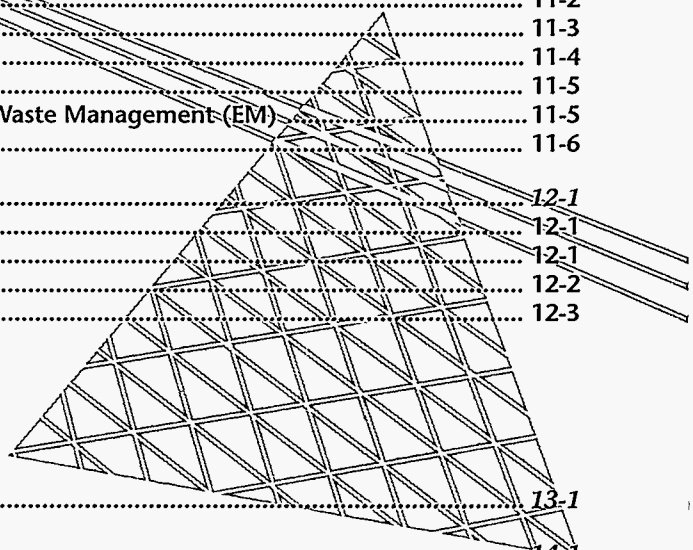

# 1 • A Message from Sandia's President and Laboratory Director, Al Narath

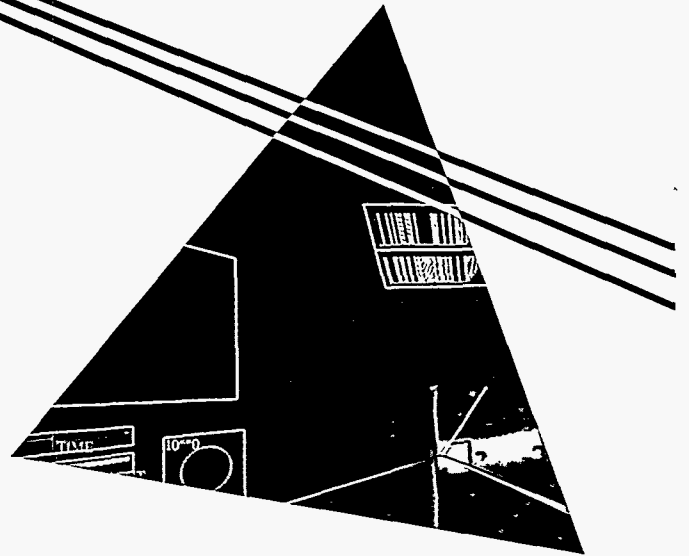

The national laboratories of the Department of Energy have a distinguished history of accomplishment. With the end of the Cold War, the laboratories face new challenges as the nation redefines its priorities. Among the important questions being debated is how to sustain the US scientific and technological strengths that provide the underpinnings for all aspects of national security, including defense, energy, environment, and economic competitiveness. Although many of the details remain unclear, there is general agreement that the nation can no longer afford two separate, relatively independent industrial bases, one focused on defense and the other on civilian needs. In response to the new realities, Sandia and the other national laboratories are implementing significant programmatic, operational, and cultural changes.

Sandia recently completed an updated strategic plan, the essence of which is presented in chapter 4. Sandia's Strategic Plan 1994 takes its direction from DOE's *Fueling a Competitive Economy: Strategic Plan* and provides tangible guidance for Sandia's programs and operations. Although it is impossible to foresee precisely what activities Sandia will pursue many years from now, the strategic plan makes one point clear: the application of our scientific and engineering skills to the stewardship of the nation's nuclear deterrent will be central to our

---

service to the nation. We will provide the necessary institutional memory and continuity, experience base, and technical expertise to ensure the continued safety, security, and reliability of the nuclear weapons stockpile.

As a multiprogram laboratory, Sandia will also continue to focus maximum effort on a broad spectrum of other topics consistent with DOE's enduring core mission responsibilities:

- Defense (related to nuclear weapons),
- Energy,
- Environment (related to waste management and environmental remediation), and
- Basic Science.

From the beginning, Sandia's strategy has emphasized a strong, integrated scientific and technological foundation as a common, unifying element that supports all our DOE customers. These mission-critical core competencies are also proving to be broadly relevant to other national priorities. This is especially true for Sandia's strategic technology thrusts in advanced manufacturing, electronics, and information systems.

Much attention has been focused in recent years on technology transfer from federally funded laboratories to the private sector as a way to enhance the return on federal investments in these institutions. In the case of small- to medium-sized enterprises, technical assistance has indeed proven to be a high value-added activity. Such assistance usually involves transfer of existing knowledge or know-how at minimal cost (especially if distributed through established assistance centers such as the National Institute of Standards and Technology Manufacturing Technology Centers), and therefore offers a large return on taxpayer investments.

For larger, technically more capable enterprises, the most productive interaction generally involves collaborative research and development. Every Sandia program, including the nuclear weapon program, offers mutually beneficial opportunities for substantial cooperation with industry and universities. It is universally recognized today that scientific and technological advances can be accelerated through joint effort. The technology transfer partnership yields a dual benefit: both DOE and the research and development partner gain from the relationship. A variety of mechanisms, including cost-shared cooperative research and development agreements, are being refined to facilitate such joint efforts. By collaborating with industry and universities in the pursuit of DOE's mission responsibilities, national laboratory contributions to industrial competitiveness and education become derivative in nature, avoiding the difficulty of justifying such contributions on the basis of a separate mission assignment.

Ensuring fairness of opportunity is an issue that arises

in every cooperative relationship involving public funding. The larger the investment, the greater the concern that the competitive playing field may be unfairly tilted. Unless the relationship is intended to satisfy a government-specific need (e.g., a defense procurement), it may be perceived as unfair if it succeeds in enhancing the profitability of the partner. For these reasons, Sandia has long favored participation in the execution of long-range technology road maps of industrial consortia or alliances that offer opportunities for significant dual-benefit contributions. Moreover, the value of such contributions can be greatly enhanced if the laboratories assist in enlarging the scope of the cooperative effort, especially in regard to participation by university researchers.

Today, industry and university partnerships permeate most Sandia programs. In general, industry partners have judged the value of their association with Sandia favorably. The feedback we have gathered is forming the basis for meaningful improvements. Our evolving strategy for technology transfer is to encourage larger alliances. In the last two years, we have begun to focus on consortia in which the capabilities of DOE laboratories, industry, and universities are combined to pursue broad research and development agendas. Many of our newer cooperative projects involve working with clusters of companies that represent a substantial segment of a specific industry or organizations that represent an entire industry.

Sandia continues to practice total quality management for improving laboratory operations and products, using the Malcolm Baldrige Quality Award guidelines as a framework. We are entering a new phase of our quality effort at Sandia—reengineering our work processes and implementing an information infrastructure to enable Sandians to operate more efficiently and effectively.

The central importance of people in achieving mission success cannot be overstated. We are committed to the continuous improvement of Sandia's human-resources policies and practices, with special emphasis on the development of a well-trained and highly motivated work force whose diversity reflects the changing demographics of American society.

In summary, I cannot recall a time when Sandia has been offered a greater opportunity to contribute to our nation's well being. I also cannot recall a time when Sandia has faced greater uncertainties. I am confident that we will be successful in meeting the challenges that lie ahead. Sandia's Institutional Plan reflects that sense of optimism.



## 2 • Sandia National Laboratories Mission

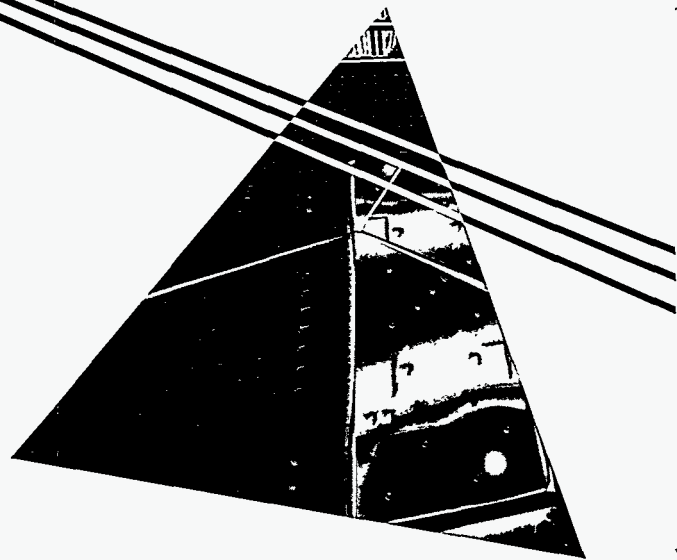

Sandia's strategic intent has always been to render "exceptional service in the national interest."<sup>1</sup> As the world has changed, Sandia has retained its focus on enhancing national security by providing solutions to technology-based problems of major national significance.

Consistent with this strategic intent, Sandia's mission statement is as follows:

As a Department of Energy national laboratory, Sandia works in partnership with universities and industry to enhance the security, prosperity, and well-being of the nation.

We provide scientific and engineering solutions to meet national needs in nuclear weapons and related defense systems, energy security, and environmental integrity, and to address emerging national challenges for both government and industry.

The specifics of Sandia's mission have evolved to meet the challenges created by a changing world, but the general thrust of our mission is unchanged. DOE, with programs in defense, energy, and environment, continues to be our principal customer.

The 1994 DOE Strategic Plan introduces a fundamental change in how the department views its defense mission—away from a model based primarily on the

production of large numbers of increasingly sophisticated nuclear weapons to a model based on the requirement for a smaller stockpile and greater attention to the threat posed by the proliferation of weapons of mass destruction.<sup>2</sup> This broadening of emphasis will place greater—not fewer—demands on the technology base that underlies defense programs.

The Defense Department's Nuclear Posture Review, completed in September 1994, outlines the foreseeable requirements of our nation's nuclear forces in the next several years. The new posture is no longer based on Mutual Assured Destruction; rather, it emphasizes Mutual Assured Safety. However, it acknowledges that neither Strategic Arms Reduction Treaty (START) I nor START II has yet been implemented, and it preserves options for our nuclear posture should reform in Russia fail. It rebalances the strategic triad of nuclear weapon delivery systems and calls for upgraded use-control technology and diligent stewardship of the stockpile by DOE. Sandia will have a major role in implementing the objectives of the Nuclear Posture Review.

<sup>1</sup>President Harry S. Truman to Mr. Leroy A. Wilson, President, American Telephone and Telegraph Company, May 13, 1949. Sandia National Laboratories Archives.

<sup>2</sup>US Department of Energy, *Fueling a Competitive Economy: Strategic Plan*, April 1994: p. 9.



Sandia President Al Narath and DOE Albuquerque Operations Manager Bruce Twining sign the contract marking Martin Marietta Corporation's assumption of management of Sandia National Laboratories.

As DOE restructures its production complex, Sandia will also assume a larger responsibility for nonnuclear component production. It is clear that DOE expects Sandia to perform a more direct role in this activity and to embrace it as an integral part of its mission for defense programs. This emerging responsibility is complemented by Sandia's integrated capability in advanced manufacturing technology, a competency that has supported DOE's production agencies for many years and will be crucial in our evolving interactions with industry.

A solid base of scientific knowledge has always been the critical factor in meeting the extreme requirements placed on the safety, security, reliability, and other characteristics of stockpile weapons. Consequently, it is DOE's goal to continually enhance the technology infrastructure and core competencies required for its national security mission.<sup>3</sup>

Long after START I and START II are implemented, Sandia will remain the nation's technical conscience for the nuclear weapon stockpile. The stockpile of the future

will comprise fewer weapon types and will rely on established designs. The institutional memory and continuity, the experience base, and the engineering expertise for nuclear warheads as integrated systems will reside at Sandia.

In addition to defense, a comprehensive definition of national security includes energy security, environmental integrity, and economic vitality. These elements are tightly interrelated. National defense requires a robust industrial base; economic vitality requires secure and affordable energy supplies; energy usage and manufacturing processes must be environmentally benign for economic growth to be sustainable.

Sandia's energy and environmental programs will also reflect changing expectations. Our stewardship of broad energy technologies will continue with renewed emphasis on making US industry successful in the global

<sup>3</sup>Ibid.: p. 23.

market. Our environmental activities will include the timely and cost-effective cleanup of Sandia sites as well as an aggressive advanced technology effort in partnership with other DOE facilities and industry.

Sandia's special mix of core competencies, talented staff, and unique facilities for DOE missions increasingly doubles as a technology resource for other national challenges. Sandia's integrated capabilities—advanced manufacturing technology, electronics technology, advanced information technology, and pulsed power technology—are strategically required for DOE's defense, energy, and environmental missions. In concert with DOE's evolving mission to provide technological support to other federal agencies, we will continue to serve as a resource to those agencies needing objective technical analyses, rapid prototyping of new concepts, or access to our special capabilities.

Over the past several years, Sandia has become a valuable resource for US industry. By partnering with industry, both one-on-one and in consortia, Sandia accelerates the advancement of technology from research through development to commercialization. In return, collaborative exchanges strengthen Sandia by exercising its core competencies and providing opportunities for direct interaction with the nation's industrial research and development base.

A strategy of great importance to Sandia involves joining forces with the complementary skills of university research laboratories. Adoption of this strategy is driven by our desire to participate in the formation and mobilization of a fully integrated technological resource for the nation. Partnerships with industry and universities increase the technological leverage we hope to gain over problems facing the nation, thereby increasing our ability to render "exceptional service in the national interest."

## Mission Focus

### Established Program Responsibilities

Established responsibilities include programs that add value directly to the nation's security, in cooperation with the private sector where appropriate, and for which the federal government is the principal customer. These programs fall into the four general areas below.

#### Nuclear Weapon Programs

These programs for DOE and DoD entail

- stewardship for and development of an evolving nuclear weapons stockpile;

- implementation of new structures and streamlined approaches to future nuclear weapon production requirements;
- assumption of some nonnuclear production responsibilities of DOE production facilities designated for closure;
- development of arms control, nonproliferation, and counterproliferation technologies, and analysis of intelligence; and
- restoration of contaminated Sandia sites to comply with applicable environmental laws and regulations.

### Energy and Environmental Programs

These programs for DOE and the Nuclear Regulatory Commission involve

- identification, development, and deployment of full systems solutions for safe, clean, and affordable energy options; and
- development of affordable and deployable environmental technologies to remediate DOE sites and for broader applications of environmentally conscious operations in industry.

### Work Other Than for DOE

This work for DoD, other federal agencies, and nonfederal agencies

- applies Sandia's capabilities to enhance the success of other federal government agencies and nonfederal entities (such as state and local governments, private industry, and universities) by providing trusted, objective, and independent technical counsel; and
- accelerates the application of integrated technology solutions to problems of national importance through partnerships with industry.

### Technology Transfer

This mission responsibility promotes and facilitates

- transfer of federally developed technologies, processes, and special technical expertise to the private sector; and
- collaborative development of technologies of mutual benefit to government and commercial applications.

---

## Technology Responsibilities

Application of Sandia's capabilities to the solution of nationally significant problems necessitates focusing on specific technical challenges through our four strategic integrated capabilities:

- advanced manufacturing technology,
- electronics technology,
- advanced information technology, and
- pulsed power technology.

Sandia regards these areas as critical to both national security in the conventional sense and to a broadly based concept of national security that includes economic competitiveness, energy security, and environmental integrity. Sandia's integrated capabilities are key areas of technology development in themselves and are also building blocks that can be applied to a variety of technol-

ogy-related problems. Sandia is currently exploring ways to employ its competencies to help solve emerging problems in biomedical systems engineering and transportation.

Other areas in which Sandia can apply its unique mix of capabilities are continually being evaluated in concert with DOE, other federal agencies, and potential industry partners.

## Approach

### Program Prioritization

Sandia will concentrate on challenges and opportunities that add value to the nation. In addition, it will

- respond rapidly to national emergencies and other urgent government requirements;
- build on and strengthen Sandia's core technical competencies and integrated capabilities;



Sandia President Al Narath talks with Executive Vice President Jim Tegnella after a ceremony acknowledging Martin Marietta Corporation's new role as managing and operating contractor for Sandia National Laboratories.

- 
- anticipate emerging trends and proactively help sponsors and customers invent their futures;
  - provide teamwork opportunities with industry, universities, and other institutions; and
  - create synergies among Sandia's program sectors and functional organizations.

## Program Execution

We strive to achieve customer satisfaction by meeting or exceeding expectations and by

- emphasizing our corporate values of integrity, quality, leadership, teamwork, and respect for the individual, and demonstrating our commitment to

the safety of the individual and to environmental protection;

- living up to our commitment to total quality management through customer focus and continuous improvement in everything we do;
- taking maximum advantage of the special characteristics of the New Mexico and California laboratories and other Sandia locations;
- partnering with Sandia's sister laboratories to build an effective system for addressing national problems; and
- working closely with universities and industry to ensure that technical developments provide the greatest possible value for the nation.



## 3 • Laboratory Management Overview

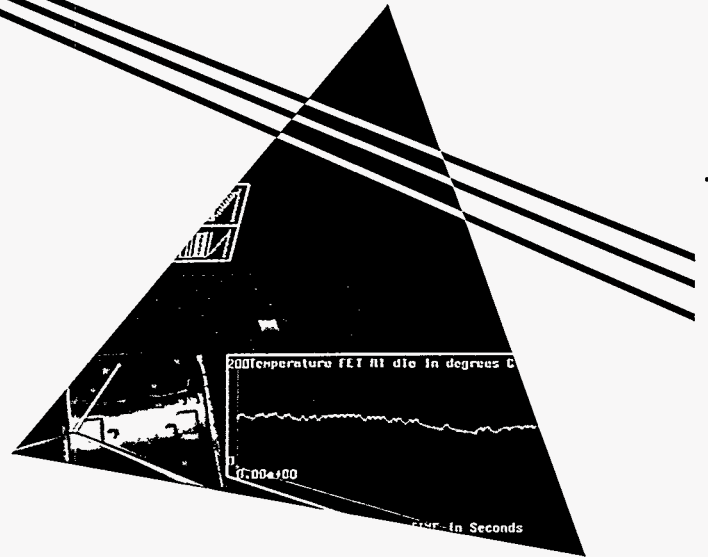

### Total Quality Management

Total quality management is Sandia's overarching management and operating philosophy. Embedded in Sandia's culture as one of five corporate values, quality is the way in which we conduct work, and it permeates all of our programmatic and institutional activities.

This commitment to total quality management is stated in Sandia's quality policy:

*To be the best demands that we integrate quality in all our work. At Sandia National Laboratories, we apply the following quality fundamentals, consistent with sound business practices, to reinforce our reputation for excellence:*

*Provide the greatest value to our customers by understanding and meeting their expectations.*

We must satisfy our customers' spoken and written requirements, and we must also understand our customers' needs and how their expectations influence their perception of quality with respect to cost, schedule, and performance. To ensure customer satisfaction, we must continually review our customers' expectations while negotiating their requirements.

*Focus on prevention rather than correction.*

Although fixing problems as they arise is important, preventing problems is our goal. Therefore, we must approach each task with the appropriate amount of planning to consider potential problems and to build prevention into each step of the process.

*Measure progress using data.*

Metrics are needed to set objectives, monitor processes, assess customer satisfaction, and ensure that resources are focused on areas with the most value added. We will use the Malcolm Baldrige National Quality Award criteria to measure our progress.

*Continually improve our skills, processes, products, and services.*

Quality improvement is ongoing. As our customers' requirements change, our capabilities must change accordingly. Continually improving our skills will allow us to serve our customers better. Because all work is part of a process, we must continually seek ways to provide the highest value products and services to our customers.

In February 1994, Sandia's Quality Leadership Council committed to the next phase of the quality improvement effort: reengineering or simplifying work processes and the dissemination of information to enable Sandians to operate more efficiently and effectively. Plans for this next stage of quality improvement are being formulated. We will select key corporate processes for analysis, followed by simplification and improvement. This will create an environment in which Sandians will experience the benefits of quality in their work lives and will be better able to meet the requirements of their customers.

Sandia's commitment to this policy requires a process that can demonstrate our success in implementing it. Accordingly, Sandia has adopted the Malcolm Baldrige National Quality Award criteria and process. In 1992, Sandia submitted its first Baldrige-type application. Our score was 429, which is very good for a research and development laboratory undergoing rapid change. We have been using the opportunities for improvement identified in the Baldrige feedback to speed progress in quality implementation. Sandia continues to use the Baldrige principles and processes for guidance.

The seven examination categories of the Malcolm Baldrige National Quality Award are leadership, information and analysis, strategic quality planning, human resource development and management, management of process quality, quality and operational results, and customer focus and satisfaction. These categories are discussed below as management objectives.

## Leadership

In January 1994, Sandia's executive management team created the Sandia Quality Leadership Council. This council will ensure that quality is an integral part of all executive meetings and actions. The Sandia Quality Leadership Council is composed of the president, the executive vice president, and the vice presidents. The new council's purposes are defined below.

### *What:*

- Continuously improve Sandia's ability to satisfy its customers and stakeholders.
- Assist in the executive decision-making process.
- Advise the executive office on corporate/strategic-level issues.
- Help ensure complete understanding of Sandia's status, as well as management and operations policy and practice.
- Set and track corporate metrics.

### *How:*

- Be well informed and prepared before meetings.
- Use total quality management processes during meetings.

- Clearly identify and assign action items.
- Build effective teams within the executive management group.

Corporate values and customer focus are the basis of Sandia's organizational structure. Sandia is organized into three sectors that account for all its programmatic work. The three sectors and their major responsibilities and customers are discussed below.

### *Defense Programs Sector*

This sector provides stewardship and development of the nation's nuclear weapons stockpile, implements new approaches to meeting the smaller nuclear weapon production requirements of the future, and develops technology for arms control, nonproliferation, and intelligence. The principal customers are

- DOE Defense Programs,
- DOE Office of Nonproliferation and National Security, and
- DOE Office of Environmental Restoration and Waste Management.

### *Energy and Environment Sector*

This sector performs research and development to improve the efficiency, safety, and environmental compatibility of energy conversion and utilization and also develops waste management solutions and technologies for industrial waste reduction. The principal customers are

- DOE Energy Efficiency and Renewable Energy,
- DOE Office of Energy Research,
- DOE Fossil Energy,
- DOE Nuclear Energy,
- DOE Office of Environmental Restoration and Waste Management,
- DOE Office of Civilian Radioactive Waste Management, and the
- Nuclear Regulatory Commission.

### *Work-for-Others Sector*

This sector applies unique Sandia capabilities to assist other government agencies in solving their problems. The principal customers are the

- Department of Defense,
- Department of Transportation,
- National Aeronautics and Space Administration, and
- other government agencies.

The organizational structure described above was implemented to increase our ability to address customers' requirements. Indicators of how well the structure is meeting those requirements are based on employee and customer-satisfaction data.

Each of the three program sectors is overseen by a sector manager who is a Sandia vice president. Because Sandia employs a program/function matrix, these vice presidents have organizational obligations in addition to their program sector management responsibilities. Twelve corporate organizational divisions managed by vice presidents support the program sectors. The support they provide may be in the form of direct programmatic work, technical support, administrative support, or laboratory indirect activities.

Corporate organizational divisions support sector programs. The intended result is that the program sectors and their customers are the focus of all Sandia activity. This structure institutionalizes the total-quality-management requirement for a dominant customer focus throughout the organization.

Strategic direction is provided by the Sandia Quality Leadership Council, chaired by Sandia's president. The Sandia Quality Leadership Council establishes corporate goals and makes decisions for infrastructure, capital, and staffing requirements for the ten-year planning horizon. It establishes a long-term strategy for core competencies and core support activities. The council integrates corporate policy with business planning requirements and projected customer needs.

The activities of the three program sectors are also coordinated in the Sandia Quality Leadership Council. The council develops direct program guidance for the three- to five-year planning horizon. It anticipates funding and spending trends and evaluates Sandia's resources. The council plans for core competencies and core support needs and develops short-term strategies for investment or disinvestment in core competencies and technical support capabilities. The council also oversees Sandia's Laboratory-Directed Research and Development Program and resolves cross-sector issues.

Sandia is a member of the National Laboratories Committee on Improving Laboratory Performance, a coordinating group composed of representatives from DOE laboratories. This committee meets to conduct comparative evaluations and share best practices.

Public responsibility is very important to Sandia and is also an important part of the leadership category of the Baldrige criteria. This responsibility is demonstrated in our policy on the health and safety of workers and the public as well as the protection of the environment. Our Environment, Safety, and Health Policy, approved by Sandia's president, clearly states this responsibility.

On the basis of Baldrige feedback, a multidisciplinary Sandia team developed seven comprehensive recommendations for accelerating our rate of quality improvement.

The Sandia Quality Council enthusiastically adopted these recommendations. Relative to the leadership category, the recommendation adopted was to "develop and review at every Sandia Quality Council meeting metrics that are corporate-wide, results-focused, and customer-oriented." These metrics provide measures of actual accomplishments against goals for important facets of our work and are being reviewed at each meeting. They were systematically reviewed at each Sandia Quality Council meeting in 1993. New metrics are being developed for review by the new Sandia Quality Leadership Council.

## Information and Analysis

Sandia's quality improvement process rests on a foundation of systems for collecting, analyzing, and disseminating data and information that will help Sandia better meet customer requirements. Data related to corporate planning, program and project planning, product and service quality, human resource planning, and compliance performance are used in all three program sectors. We use this information to measure, evaluate, and control processes, to forecast performance and results, and to identify opportunities for improvement. Each sector has a support office to manage such data. For example, the energy and environment sector has a monthly data package that tracks a variety of information at both the sector and the program levels.

From the Baldrige feedback, the recommendation to "develop a flexible system that facilitates management decision-making based on data" was adopted. Key managers from the program sector offices are completing the development of this system and have begun to implement aspects of it.

Benchmarking, an important element of this category, spans all other categories as well. Another recommendation derived from the Baldrige feedback has been adopted and is being implemented: "Benchmark one key process each from corporate-wide processes, each sector, core competencies, and critical support services." A systematic study of Sandia's benchmarking efforts revealed that over eighty benchmarking efforts have been undertaken or completed.

As part of the next step, reengineering and simplifying key processes, Sandia will benchmark processes to be reengineered.

## Strategic Quality Planning

Sandia's first strategic planning effort produced a strategic plan that set the stage for a change in corporate culture. The plan incorporated a mission statement that

---

broadened Sandia's traditional focus on the defense aspects of national security in order to "enhance the security, prosperity, and well-being of the nation." The plan also articulated a statement of corporate values and a set of strategic corporate objectives. Quality in all its aspects was incorporated in these values and objectives.

Sandia embarked on its first exercise in corporate strategic planning during the winter of 1989-1990. The results of that effort were disseminated with the publication of Strategic Plan 1990. That document was the first of its kind in the DOE community (although strategic planning was widely practiced in industry) and despite its shortcomings received significant acclaim. The Secretary of Energy called it "an excellent example of the type of planning effort expected of our laboratories, especially with the need to change our culture in response to today's changing demands."

The emphasis in that first effort was on changing our culture. Today, the evidence of such change is unmistakable: As an organization we are more entrepreneurial and assertive. We have nurtured a new teamwork relationship with DOE and with industry. We have embraced total quality management and become more customer-oriented. We are more flexible in our management style, and decisions are more often the result of participatory processes.

That evolving cultural change was necessary to set the stage for a strategic plan with a stronger business focus. A new strategic planning cycle was initiated in 1994, and a new strategic plan was published that year. Strategic Plan 1994 differs from its predecessor by providing more tangible business guidance to laboratory sectors and divisions.

We are now designing our operational and business planning processes with quality principles in mind. Business plans will of necessity focus on customer needs and on the products and services Sandia offers to meet those needs. Business plans will provide program managers and organizations with clearer direction, and should positively impact employee satisfaction.

## Human Resource Development and Management

Sandia recognizes that its employees are its most important strategic asset in meeting customer requirements and fulfilling the strategic intent of "exceptional service in the national interest." We are committed to the quality principle that the degree to which Sandia achieves employee satisfaction will be the degree to which Sandia meets customers' requirements. Because Martin Marietta Corporation (Sandia's new managing contractor) recognizes that employees are so important, it established a vice presidency of Human Resources at Sandia and filled the position with a senior Martin Marietta executive.

To support Sandia's performance in human resource management, we completed our first Strategic Human Resource Plan in 1992. This plan is guiding our actions in human resources in four key areas: staffing, performance management, leadership and management development, and diversity. The plan will be updated periodically to ensure relevance and continuous improvement.

On the basis of the Baldrige evaluation, Sandia developed and adopted the following activity in this category: "Use industry 'best practices' to establish a corporate education and training program." Important elements of this activity include the development of a Sandia-wide education policy and funding to implement this policy. In 1993, the policy was developed and presented to the Sandia Quality Council for consideration. A task force of directors headed by the vice president for Laboratory Development continues to implement this policy.

In further support of human resources management, Sandia held a two-day conference on human resource development for senior managers in January 1994. Sandia has also made significant progress in its commitment to ethnic, racial, and gender diversity by establishing diversity action teams and identifying diversity champions at all organizational levels.

A second human resources activity based on the Baldrige evaluation is to "align the performance and recognition system with corporate values and sector goals." Implementation of this recommendation began in 1992 with establishment of a performance management system for vice presidents and directors. Sandia is now in the process of cascading this system to all employees. Performance management plans will be in place for all Sandians for the 1994-1995 performance year.

To recognize outstanding contributions by teams using quality processes, Sandia President Al Narath created a President's Quality Award in 1993. Modeled after Baldrige but simplified for use by teams, the President's Quality Award is based on published criteria, defined application procedures, and a rigorous examination process to determine the winners. Awards are at three levels: gold, silver, and turquoise. In November 1993, President Narath presented five silver and twelve turquoise awards to seventeen teams. In 1994, the President's Quality Award will have two categories: one for products and one for processes. Both will emphasize the use of quality methods, with the product category recognizing contributions of products that support Sandia's mission success.

## Management of Process Quality

Sandia's approach to managing process quality is tailored to fit the particular product or service delivered

---

to the customer. We identify customer expectations, clarify them through discussion, and translate them into specific requirements. Although all program sectors use standard project management techniques (including multilevel work breakdown structures, task metrics, and critical path networks), individual approaches will vary to meet sector and customer requirements.

Our largest sector, defense programs, has a prevention-based system to assure the safety, performance, and reliability of US nuclear weapons. Great rigor, attention to exacting requirements, well-defined processes, exacting engineering development, and sedulous attention to all aspects of quality have been the hallmarks of this work for more than forty years.

All three sectors use a graded approach to determining the level of formality to use in meeting customer requirements. In the work-for-others and energy and environment sectors, requirements for some activities (such as the Yucca Mountain and Waste Isolation Pilot Plant nuclear waste repository projects) are set by statute.

Customer requirements are often subject to change during the life of programs and projects. The Baldrige feedback provided an opportunity to improve in this area and resulted in the development and adoption of a recommendation to "develop a structured but flexible approach to managing customer interfaces." The three sectors are implementing this recommendation through structured approaches to customer interactions, defined responsibility in interactions with customers, customer databases, and customer satisfaction surveys. We anticipate an improved ability to achieve customer satisfaction through these new approaches to customer interfaces.

## Quality and Operational Results

In the defense programs sector, a key product metric of interest to customers in DOE and DoD is the reliability of the weapons in stockpile. The emphasis on reliability starts with the weapon development program and continues through the entry of weapons into the stockpile. Reliability assessments are made by an organization independent of design responsibility. Continuous quality improvement has led to significant improvements in all indicators, such as decreases in component failure, decreases in average defects per weapon, reduced need for tests in the stockpile evaluation program, and a downward trend in investigations of significant findings.

In the work-for-others sector, the Aerospace Systems Development Program and the Remote Sensing and Verification Program have identified key measures for product or service quality. For Aerospace Systems Development, the key measure is the percentage of flight test objectives met. This measure indicates a continuous trend upward for more than twenty-four years. For

Remote Sensing and Verification, mean time between failures for flight payload is measured. This key measurement indicates a failure rate of less than one per billion operating hours. A mission failure has not occurred in thirty years of fielding satellite systems.

Sandia has an excellent history of meeting customer cost, schedule, and performance requirements. Sandia depends on the support of internal organizations (including Information Systems, Purchasing, and Facilities and Maintenance) to make this quality success possible. These organizations are making greater use of customer satisfaction surveys to identify and implement opportunities for improvement.

The work process reengineering and simplification should enhance our ability to produce excellent operational results.

## Customer Focus and Satisfaction

Sandia is implementing a process to achieve continuous improvement in customer focus and satisfaction. DOE is Sandia's principal customer; DoD is also a key customer. However, Sandia has many other DOE and reimbursable customers as well. New customers include private sector partners in cooperative research and development and other beneficiaries of our technology transfer efforts. Each sector has developed specific organizations and processes for providing customer focus.

The development and implementation of the DOE Laboratory Appraisal System for Sandia was a direct effort to improve the extant appraisal process. We worked directly with DOE to develop and introduce the improved process. An important aspect of the new process is that DOE co-owners work directly with Sandia owners to develop activities to be appraised and the methodology for the appraisal.

We are working with DOE on the appraisal process to put greater emphasis on costs. In the future, funding for nuclear weapons programs will almost certainly decline, and we are using the appraisal system to enhance awareness of the importance of fiscal management.

Sandia's commitments to its DOE Defense Programs customer begin with directives and interagency agreements implemented through formal requirements, documents, and procedures. These commitments are for the life of a weapon.

The primary commitment with work-for-others customers is the reimbursable agreement signed by Sandia and approved by DOE. All reimbursable proposals and agreement packages are reviewed for quality, ability to perform, and adherence to DOE and federal requirements.

The growing number of industrial and other private-sector partners in unclassified research and development will have profound effects on the way Sandia interfaces with customers. This trend will require cultural change,

---

changes in procedures for controlling new types of information, and physical changes to sites and facilities, including the development of more open laboratory campuses in a research park environment in both New Mexico and California.

Vice presidents personally collect feedback from major customers. Many directors and managers also personally contact major customers. A new center has been established in Carlsbad, New Mexico to work on customer relations for the Waste Isolation Pilot Plant.

The process reengineering effort should produce its highest leverage results by increasing Sandia's ability to satisfy customers.

## Core Competencies

Core competencies represent a distinguishing integration of skills, capabilities, technologies, and facilities needed to perform Sandia's mission and achieve strategic objectives. Core competencies make it possible for Sandia to solve a wide variety of technical problems; core competencies represent a complex harmonization of individual skills and technologies that would be difficult for other laboratories to duplicate. Each of our core competencies makes a significant contribution to the value of the products and services for which Sandia is responsible, and many groups within Sandia rely on the core competencies to accomplish their work.

The core competencies are a matrix of research foundations and integrated capabilities, and they make science-based engineering and product realization possible. The research foundations derive scientific and engineering principles. Those principles are used to advance the integrated capabilities that are crucial to Sandia's programs.

## Research Foundations

### *Engineered Processes and Materials*

This competency entails synthesis, characterization, and processing of metallic, ceramic, organic, and composite materials. A distinguishing strength of this competency is the development of advanced materials and processes tailored to meet the needs of a specific application.

### *Computational and Information Sciences*

This competency provides technology to advance state-of-the-art computer use while maintaining the accuracy, security, and accessibility of information. Distinguishing strengths of this competency include the development of advanced computing networks and facilities, computational methods for emerging computer technologies,

mathematical techniques for information surety, and computer-based techniques for intelligent machines.

### *Microelectronics and Photonics*

This competency contains the technology required for development, fabrication, and production of microelectronic and photonic devices. Distinguishing strengths of this competency include materials growth and development, device design, fabrication technologies for silicon and compound semiconductor devices, advanced packaging technologies, and design of processes and equipment for the manufacture of integrated circuits.

### *Engineering Sciences*

This competency consists of fluid and thermal sciences, solid and structural mechanics, radiation transport, aerospace sciences, geosciences, and combustion sciences. A distinguishing strength of this competency is the development of interdisciplinary capabilities and an integrated computational and experimental approach for solving complex engineering problems.

## Integrated Capabilities

Integrated capabilities are advancing technologies that derive their scientific basis from the research foundations. The four integrated capabilities identified below are all important to direct programs at Sandia. All are important for the private sector as well. Pulsed power technology will remain a critical but very specialized capability germane to DOE defense programs missions. These integrated capabilities are significant to US competitiveness and have great dual-benefit potential.

### *Advanced Manufacturing Technology*

This competency contains the technology to meet the manufacturing needs of US industry and the nuclear weapons complex. Examples of these needs include concurrent engineering, intelligent machines for hazardous and flexible operations, computer-aided design/engineering/manufacturing, engineered processes and materials, environmental protection and control, and an infrastructure to support product realization. The applications of this competency are distinguished by an emphasis on precompetitive research and development for market-driven technologies that are guided by the reconfiguration of the nuclear weapons complex and by industry-led associations such as the US semiconductor SEMATECH consortium, the United States Council for Automotive Research, and the Specialty Metals Processing Consortium.

### *Electronics Technology*

By leveraging Sandia's research foundation in microelectronics and photonics, we apply our electronics technology to enhance the safety, security, and use-

control of nuclear weapons; make continuing contributions to defense, including new technologies to discourage the proliferation of weapons of mass destruction; and expand our contributions to the nation's economic security by targeting major needs in commercial technology. Through cooperative work with industry and universities, our integrated capability in electronics technology enables Sandia to maintain a state-of-the-art electronics technology base and provide value to industry.

### ***Advanced Information Technology***

High-performance computing, computational simulation, and networking have an increasing role in enhancing the security and economic prosperity of the United States. Sandia provides differentiating expertise in information technology and systems to weapon programs, related mission programs, other integrated capabilities, and national information initiatives.

### ***Pulsed Power Technology***

Pulsed power technology is used to generate and apply energetic beams and high-power energy pulses. It is distinguished by the development of repetitive pulsed-power technologies, x-ray and energetic beam sources, and electromagnetic and radiation-hydrodynamic codes for a wide variety of applications. Examples of these applications include nuclear survivability and hardness testing, light-ion-beam inertial confinement fusion, materials processing, waste and product sterilization, and food purification. Facilities include the Saturn x-ray source, the High-Energy Radiation Megavolt Electron Source (HERMES) III for gamma rays, and the Particle Beam Fusion Accelerator II.

## **Laboratory-Directed Research and Development Program**

The Laboratory-Directed Research and Development (LDRD) Program became permanent at Sandia in FY 1983 as permitted by federal law (Public Law 95-39, Section 303) and DOE Order 5000.4A. The LDRD Program provides support for science and technology activities related to DOE's missions. Projects emphasize advanced science and technology that enhance Sandia's research and development capabilities and core competencies.

LDRD must be relatively small, well-specified, short-term (one- to three-year) technology and application projects that establish new capabilities, test new concepts, or investigate innovative approaches. LDRD funds are not used to substitute or increase funding for tasks already funded by DOE or other agencies or to carry projects beyond the exploratory stage.

LDRD funds are derived from an assessment on

funding from all sources, including DOE programs. In FY 1994, the program was funded at about \$63 million.

LDRD permits Sandia staff to explore innovative scientific and technological opportunities that hold high potential for payoff in applications. Some of these projects have led to new DOE tasks and projects; others have enhanced Sandia's core capabilities.

LDRD had significant successes in FY 1993. Investigators demonstrated proof-of-principle for superconductive positioners and accelerometers ten thousand times more accurate than conventional piezoelectric units. This technology will make possible detection instruments based on gravitational signatures that are not susceptible to stealth technology. Investigations into electrophoretically deposited (water-based) solid lubricants have produced environmentally acceptable processes and materials with lower friction coefficients than existing approaches.

LDRD-developed, scaleable flat-flame technology for the production of diamond films makes possible the commercial production of thin diamond films required for the next generation of multichip electronics modules. Research into electron behavior in nanostructures (based on small-sized quantum effects) is revealing new phenomena and operating principles for electronic devices of the future.

Selecting LDRD projects is a formal process. Each fall, the LDRD Council identifies core competencies that will constitute LDRD Program elements for the following fiscal year. At this time, the council also establishes LDRD budget targets for the program elements. The Sandia Quality Leadership Council reviews and approves the elements and budget for the program. Next, a call for proposals is issued describing the intent of the program, the program elements, and requirements for submittals. Investigators who wish to extend a project beyond one year must submit a renewal proposal for continuation of funding. The renewal request must detail progress achieved toward project milestones and describe the tasks to be performed in the next year.

Proposals are subjected to two independent evaluations. A technical appraisal team evaluates the content of the proposed work, the technical approach proposed, and the technical potential of the project. Proposals are also subject to a programmatic evaluation by one of several review boards. In this evaluation, proposals are reviewed for growth potential, impact on future activities, and agreement with Sandia's strategic intent. The programmatic appraisal team ranks the proposals in its program area in order of funding preference.

Based on the review rankings and budget targets approved by the Sandia Quality Leadership Council, Sandia's LDRD Program manager prepares a proposed LDRD Program. A program plan is then prepared and submitted to DOE for a project-by-project review. Sandia and DOE then jointly modify the proposal to develop a plan that meets all DOE requirements. DOE is responsible for final concurrence with the program plan.

---

## Facilities

Sandia's executive management offices and larger laboratory complex are located on Kirtland Air Force Base at the southeastern edge of Albuquerque, New Mexico. This site, referred to as Sandia/New Mexico, is composed of five technical areas and an expansive outdoor testing field covering 17,750 acres. This location benefits from its proximity to other major defense laboratories and testing facilities and the emergent high-technology industrial climate in the Rio Grande research corridor.

Another Sandia complex in Livermore, California occupies 413 acres at the eastern edge of the San Francisco Bay area. The site benefits from its proximity to world-class research universities and the intense high-technology environment of the region. Sandia/California is strategically important to Sandia's missions because it is a window to the leading industrial centers of the West Coast and a connection to the challenges of twenty-first-century urban America.

Sandia operates a wide variety of technical facilities, which constitute one of the world's premier research, development, and testing complexes.

Extensive research laboratories for physical and chemical sciences, materials and processes, computational and computer sciences, microelectronics and photonics, pulsed power, and engineering sciences contain the most modern instrumentation and laboratory equipment. Similarly, extensive engineering development laboratories contain unparalleled facilities for component development, particularly in electronics, manufacturing, and processes.

Collectively, Sandia's array of environmental testing facilities is not duplicated anywhere else in the world. In addition to shock, temperature, vibration, and acceleration test facilities used to subject a variety of components and systems to a wide range of extreme environments, Sandia operates a variety of special-purpose test facilities, some of which are unique: a radiant heat facility; a multiple-stroke lightning simulator; a low-field, broadband electromagnetic radiation facility; blast tubes capable of operating from 1 to 2,000 pounds per square inch; a facility to provide large quantities of molten metal oxides for studying nuclear reactor accident conditions; light-initiated and other high explosives test facilities; a 5,000-foot aerial cable for impact tests; a 10,000-foot rocket sled track; and two of the world's largest centrifuges.

Many of Sandia's specialized facilities constitute major national resources, utilized for a variety of both defense and nondefense research and development programs:

- Computing facilities, from modern workstations to massively parallel computing, support Sandia's pervasive use of computation for the simulation and

modeling of complex phenomena and concurrent research, development, and engineering.

- A sophisticated, multivendor, corporate internet-network and communications infrastructure provides ready access to Sandia's supercomputers and storage servers from both the California and New Mexico locations and their distributed networks.
- Robotics laboratories are used for basic scientific research and engineering development of prototype advanced systems with application to DOE weapon production efforts. Applications include START-mandated nuclear weapon dismantlement and retrieval and repackaging of radioactive wastes.
- The Center for Microelectronics Technologies and the Integrated Materials Research Laboratory are used to study semiconducting and other specialized materials.
- Advanced facilities exist for materials synthesis, growth, processing, and diagnostics. Facilities house equipment for molecular beam epitaxy and metal-organic chemical vapor deposition growth, accelerators for ion-beam analysis and ion implantation of surfaces, solid-state and gas-phase lasers for spectroscopy and remote sensing, and equipment for numerous surface analytical techniques for microstructure and materials property analysis.
- The Integrated Manufacturing Technologies Laboratory and the National Center for Advanced Information Components Manufacturing provide advanced manufacturing technology capabilities for developing integrated and agile solutions to manufacturing problems for industry and government partners. Dual-use and commercial relevance are priority requirements.
- The Combustion Research Facility in California is addressing problems in combustion science, energy, and the environment.
- The National Solar Thermal Test Facility and other solar thermal facilities are used to test central and distributed receivers and to study high-temperature materials and processes. The Advanced Photovoltaics Facility is used to test both flat-plate and concentrator systems.
- Reactor facilities are used to simulate internal environments of power reactors and to evaluate the effects of nuclear weapons on components.
- The Particle Beam Fusion Accelerator II, the Saturn x-ray simulator, and the Hermes III gamma-ray



accelerator are used to simulate nuclear weapon effects and to study pulsed power approaches to fusion energy.

- Dedicated facilities and test equipment at DOE's Pantex plant in Amarillo, Texas are used for quality assurance and stockpile evaluation operations.

Sandia's 988 buildings provide laboratory, shop, and office floor space of approximately 5.8 million gross square feet, most of which is located on about thirty square miles of the southern part of Kirtland Air Force Base. At original acquisition cost, the facilities available at Sandia represent nearly \$1.5 billion of US government assets, consisting of about \$900 million in capital equipment, more than \$500 million in buildings and structures, and more than \$50 million in utilities and land improvements. The investment in technical equipment amounts to more than a quarter million dollars per technical employee.

As its mission evolves, Sandia, like other national laboratories, is working much more closely with US industry. Relationships with industrial partners require easier site access and appropriate security management. We are exploring concepts for changes in campus configuration at both our New Mexico and California sites to facilitate access by industrial users. Changes are likely to affect classified and unclassified business areas, traffic circulation, parking, and other infrastructures. A significant investment will be required for this site conversion work to improve the logistics of working on national, industry-led initiatives.

## Human Resources

Sandia's employees are key to mission success. In the current environment of evolving work priorities, continu-

al change, and fluctuating budgets, Sandia intends to fully utilize the talent and spirit of the work force, thereby gaining a strategic advantage for Sandia and its customers. To develop and deploy Sandia's employees as a strategic advantage, the human resources infrastructure must be integral to and supportive of Sandia's business intent and must ensure management practices that are responsive to employee needs.

Toward this end, Sandia has developed a strategic human resource planning process to achieve long-term programmatic goals within the context of changing work requirements and evolving demographic and societal trends. This process is the mechanism by which work force composition and utilization, environmental requirements, and goals to meet legal and regulatory requirements will be forecast, planned, and delivered. Planning is done via a partnership between human resource program managers and line executives, who are jointly responsible for strategy formulation and implementation. The process is modeled on the Malcolm Baldrige approach to quality improvement, and incorporates the key Baldrige elements for human resource development and management. The principal desired outcome of implementing the Strategic Human Resource Plan is a work force of talented, creative people dedicated to "exceptional service in the national interest."

Sandia's 5,312 technical professional and support personnel are drawn from all disciplines of engineering and the physical sciences. Averaging approximately fifteen years of service to the nation, the technical staff represents almost 80,200 man-years of experience. That reservoir of expertise has produced fifty-six patents during the past two years. About 62 percent of the 3,893 members of the professional technical staff have engineering backgrounds, with most holding degrees in electrical, mechanical, or chemical engineering. The remaining 38 percent have expertise in a variety of technical disciplines, including nuclear engineering, mathematics, physics, computer science, aeronautics, and materials science. Seventy-seven

Laboratory Staff Composition

	<u>PhD</u>	<u>MS/MA</u>	<u>BS/BA</u>	<u>Other</u>	<u>Total</u>
Professional Staff (Including Management):					
Engineers	673	1,168	263	22	2,126
Scientists	707	391	146	22	1,266
Other Technical	3	57	27	414	501
Administrative	43	527	229	116	915
Support Staff:					
Technicians	1	12	133	1,273	1,419
All Other	1	33	191	2,087	2,312
Laboratory Total Staff	1,428	2,188	989	3,934	8,539

---

percent of the professional technical staff have graduate degrees, 46 percent of which are PhDs.

Supporting the professional technical staff are 1,461 technicians possessing hands-on experience across a variety of technical specialties. Administrative and indirect support is provided by more than one thousand professional management and administrative personnel, nine hundred administrative support personnel, and 1,550 union-represented employees who perform security, craft, maintenance, and clerical functions.

Although most of Sandia's employees are based in New Mexico, about 1,050 are employed at the California facility; another one hundred employees are in small groups at the DOE Pantex plant in Amarillo, Texas and at the testing sites at Kauai, Hawaii and Las Vegas, Nevada.

The combination of outstanding technical staff and unmatched research, development, and testing facilities continues to permit Sandia to leverage technology to address important national problems.

# 4 • Laboratories Strategic Plan

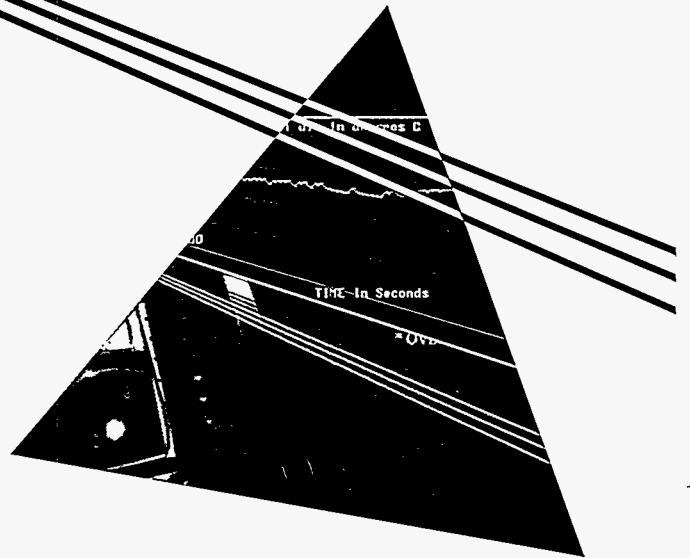

## Situation Analysis

Sandia's mission has evolved to meet the challenges created by a changing world but the general thrust is unchanged. DOE programs in defense, energy, and environment continue to be our principal mission.

However, Sandia's operating environment has changed dramatically during the past few years. On the international level, the Soviet Union has collapsed and the Cold War has ended. However, old animosities and new threats to stability make it clear that the world remains troubled and unpredictable.

A series of important developments has impacted DOE's weapons program. These developments include the sweeping arms control initiatives of 1991, the indefinite moratorium on nuclear weapon testing, and the discovery of advanced nuclear weapon development programs in Iraq and North Korea. The proliferation of weapons of mass destruction and the potential for nuclear terrorism are emerging threats.

The 1991 war with Iraq reminded the world of the strategic importance of energy. It demonstrated the overwhelming dominance of oil in the industrialized world's energy mix, and it forced the United States to reexamine the energy choices it had made. Even though

the war was quickly won and the immediate threat removed, the strategic issues associated with our chronic dependence on foreign energy sources remain.

Environmental awareness has increased worldwide. Pollution from industrial sources is catastrophic in many regions of the former Soviet Union. In the United States and other affluent nations, industry is adopting cleaner manufacturing processes and designing products that have smaller environmental consequences throughout the product life cycle. Many governments, especially in developing nations, are concerned about problems such as hazardous waste, water, energy, and resource depletion. Many poor nations have experienced extensive environmental degradation.

In our own country, the attention of policy makers has shifted to domestic problems that have become real threats to the prosperity and quality of life that most Americans enjoy. The vitality of the US manufacturing sector is a source of concern, particularly with respect to the supply of good jobs for Americans. Transportation, the environment, crime, education, and affordable and accessible health care are examples of other urgent issues.

Recently a debate has emerged about the utility of the national laboratories with respect to these new priorities: Does their contribution justify their cost? Should they have additional roles and missions that address emerging

national priorities? Or should their missions be more narrowly circumscribed and their activities constrained?

Clearly, we will be expected to manage and operate the laboratories more cost-effectively than ever before. Modern business methods, agility and flexibility, and reengineered work processes will be required to meet this challenge. But even with these changes, we will continue to feel the constraints of declining program resources.

Strong public and official sentiment exists for dramatically reducing the research and development base that supports nuclear weapons. However, an important dilemma emerges: Nuclear weapons will continue to be a component of our nation's defense. They will age beyond their designed service lives and their constituent technologies will become obsolete. Conversely, the requirements and expectations for reliability and surety will increase as the stockpile becomes smaller and new technology makes improvements in safety and control feasible. These expectations cannot be satisfied without sustained, predictable funding for the integrated science and engineering programs that support nuclear weapon technologies.

Sandia's operating environment has, in general, become more difficult and less certain. As we plan, it is important that we identify and interpret the external forces that will influence our future.

## Planning Assumptions

Strategic objectives and general strategies are based on sets of planning assumptions in defense, energy and environment, technology, economics, politics and society, and laboratory operations.

## Defense

- Sandia's nuclear weapons stewardship responsibility will demand sustained support of our science and engineering research and development capabilities, particularly as we enter an era with no new weapon development programs, no nuclear testing, and declining budgets.
- Restructuring the nuclear weapons complex will last a decade and will force hard decisions about research and development, production, and remediation.
- The defense budget may decline even further before it stabilizes. Competition for allocations from the research and development portion of that budget will certainly increase.



Five members of the team working on Sandia's Strategic Plan are shown at a working session. Team members are (from left) Bert Westwood, Mim John, Virgil Dugan, Jerry Langheim, and Dan Hartley.

- Weapons of mass destruction will continue to proliferate, and the probability that they will be used in a regional conflict is increasing.
- For the foreseeable future, the stockpile of US nuclear weapons is not likely to get much smaller than the limits specified in the START II agreement.
- The moratorium on nuclear testing will challenge our technical skills as we strive to fulfill our responsibilities for nuclear weapon surety and reliability.

## Energy and Environment

- Environmental considerations will become a dominant factor in decisions related to energy, transportation, and manufacturing.
- Environmental restoration and public health and safety will continue to be high priorities for the government and the public.
- Demand from developing nations for energy resources will grow.
- Responsible environmental stewardship will be required across the entire product life cycle.
- Permanent disposal of nuclear waste will be key to the future of nuclear power and essential for managing the nuclear weapons program.
- Conservation and renewable energy alternatives will be seen as viable strategies for improving US energy efficiency.
- The energy supply industry has lost most of its in-house research and development capability and will need alliances with national laboratories and universities in order to advance.
- The strategic importance of domestic oil production and alternative energy supplies will become more widely acknowledged.

## Technology

- US industrial firms will not rebuild their research infrastructures but will rely on alliances and partnerships to provide technologies for the future.
- The importance and influence of information technology will increase throughout industry.

- Cycle time for technology deployment will continue to shrink.
- The need to modernize our nation's infrastructure will create new technological challenges.
- Manufacturing will be a major factor in the nation's economic vitality.
- Technology will not automatically be viewed as the solution to many of the nation's problems; it may be seen as the source of some of those problems.

## Economics

- The trend to integrate the civilian and defense industrial bases will continue.
- Alliances and consortia involving national laboratories, industry, and universities will become generally accepted, and cooperative ventures with industry will expand.
- Pressure on discretionary federal spending (including defense and research and development) will become more intense.
- The increasing globalization of business will make it difficult for national laboratories to provide technology for the exclusive benefit of US companies.
- Initiatives for US industrial technology leadership will mature into sustainable joint technical pursuits to which the national laboratories can contribute.

## Politics and Society

- Technical programs will be more open to public scrutiny. Increasingly they will be subject to debate concerning their ethical, social, political, economic, and environmental impacts.
- In the future, laboratory initiatives will require support from a broader political base than they have in the past.
- The federal government's effort to make government more efficient and cost-effective will have significant impact on the national laboratories.
- Diversity of ethnicity, gender, age, and skills will increase among our own work force and that of our customers.

- Society will continue to exhibit a strong aversion to risk imposed on individuals from any source other than through choices made by individuals themselves. To the degree that technology can contribute to reducing risk, opportunities to apply technology in new and useful ways will present themselves.

## Laboratory Operations

- The ability to develop and apply human resources and technical expertise in an agile manner will be critical to Sandia's success.
- Sandia's California site will remain a strategic asset, integral to our success by serving both as a window to the West and the Pacific Rim and as a gateway into Sandia.
- Our pursuit of quality will require us to place more emphasis on operational efficiency and cost-effectiveness.
- Reengineered work processes and a modern information and communications infrastructure will become increasingly important to the efficiency of our operations and the quality of our work.

## Strategic Objectives

Strategic objectives are established for both what we do and how we do it. As a mission-oriented laboratory, we have obligations to our sponsors for programmatic results as well as a general obligation to the taxpayers to produce value for the investment they have made in us. Consequently we call one subset of strategic objectives "mission objectives." These are concerned with our programmatic responsibilities and the technical foundations for our work.

A second subset of strategic objectives is concerned with the administrative management and operation of the institution. These "operational objectives" support the successful realization of mission objectives and are equally important.

To a large extent, Sandia's long-term viability will depend on how well it meets its mission and operational objectives. We think that all the objectives below are achievable and that progress toward meeting them can be measured by performance indicators.

## Mission Objectives

### Mission Success

Sandia's objective is to achieve mission success and customer satisfaction through superior technical execution and program management. We will identify and develop products based on Sandia's strategic thrusts (advanced manufacturing, electronics technology, advanced information technology and pulsed power technology) in all three sectors.

DOE missions will remain our primary focus. We will make every effort to help DOE succeed in meeting its mission objectives. Within the system of DOE laboratories, Sandia has outstanding comparative advantages based on a heritage of industrial management and a philosophy of science-based engineering and product realization. We will further define and strengthen our missions base by cultivating these comparative advantages.

We will work with DOE to devise more efficient funding vehicles for work with other federal agencies, state and local governments, and industry. We will also work with DOE to develop innovations that will permit Sandia and the other DOE laboratories to make maximum contribution to US technology needs in defense, energy security, environmental integrity, industrial technology, and other national technology initiatives.

We will attract new federal government customers by offering products and services that can provide substantial benefit to their programs. Sandia should be the national laboratory of choice based on observable comparative advantages and quality performance demonstrated in its work for DOE. New programmatic work for other agencies must exercise our research foundations and strategic thrusts. We will encourage DOE to negotiate top-level agreements with other agencies to establish long-term, team relationships for work in areas of mutual benefit.

We will aggressively seek funding under new federal technology initiatives when we believe our DOE mission capabilities can add unique value. Substantial in-house technical work will be a requirement of any program we accept. We will not accept funding where we add little technical value to a program.

Our participation in new federal technology initiatives will involve collaboration with industry groups, perhaps in technical competition with other laboratory/industry teams. This may become a new model for federal research and development procurement, one that affords the government greater confidence in technical proposals and provides a more informed basis for selection.

## Defense Programs (Including Nonproliferation)

Five programmatic thrusts have been established to support and parallel DOE's National Security Strategic Plan. They are synergistic and integrated with Sandia's integrated capabilities (advanced manufacturing technology, electronics technology, advanced information technology, and pulsed power technology) and are supportive of these capabilities in the other Sandia sectors. Plans and strategies to support these capabilities are judged against strategic investment criteria.

### *Stewardship of the Stockpile*

We will ensure that the stockpile remains effective, and we will create executable options to evolve the stockpile of the future. In addition, we will assure that the nuclear weapon development capabilities and expertise necessary to meet the nation's future needs are maintained.

The strategic opportunity is to advance the science and technology of nuclear weapon design and manufacturing in many areas, such as model-based development, state-of-health self-surveillance, stockpile tracking and inventory, advanced surety, and innovative system concepts to meet possible future threats while utilizing these advanced nuclear weapon design science and technologies to address other national technical problems.

### *Reconfiguration and Conversion*

We will support national defense policy and DOE policy by taking actions necessary to reduce the size of the nuclear weapons stockpile while integrating the design and production capabilities to support the remaining stockpile and perform upgrades or new builds if necessary. The budget decreases associated with a reduced stockpile will require a significant reconfiguration of the nuclear weapons complex and the adoption of more cost-effective product realization processes.

The strategic opportunity is to use systems approaches for weapons production to demonstrate successful low-volume, high-reliability design and manufacturing processes through the incorporation of modern product realization principles such as agile manufacturing, concurrent engineering, and environmentally conscious manufacturing.

### *Strategic Surety*

It is our responsibility to develop the technical means to assure confidence in the safety, security, and control of nuclear weapons in all environments. The ability to

attain this confidence now and in the future for nuclear weapons and other high-consequence activities is of strategic importance to the nation. We will develop and promulgate the underlying science, technologies, methodologies, prototypical components, and system architectures for the advancement of surety.

The strategic opportunity exists for the development of goals, standards, and objectives and the implementation of system architectures and supporting technologies for achieving intrinsic surety so that undesired actions are not possible without official intent. These developments will provide the framework for the application of the science of surety to other high-risk national problems such as civil security (e.g., from acts of terrorism), information security, transportation safety, and medical treatment safety.

### *Competencies and Capabilities*

We will preserve, sustain, and continually enhance the core intellectual, technological, and physical infrastructure necessary for the support of all the missions and responsibilities of the nuclear weapons complex. To accomplish this, we must exercise these essential capabilities and competencies to meet a wide range of national needs, including the enhancement and preservation of US industrial capabilities.

The strategic opportunities are to

- develop complementary support for competencies and capabilities through all lines of Sandia's business and discretionary funding sources, such as laboratory-directed research and development;
- strengthen Sandia's science and technology base by identifying opportunities to leverage cross-sector investments in new competencies and capabilities;
- anticipate and strengthen those competencies that will be required for Sandia's evolving missions, such as advanced manufacturing, sensors for smart weapons, microelectronics, advanced modeling and simulation for design engineering; and
- develop technology partnering activities that yield significant spin-back of new or enhanced competencies and capabilities.

### *Responding to the Changing Threat*

We will bring the full range of our technology base and systems integration competency to bear on the problem of developing technical approaches to address the evolving security challenges posed by the proliferation of weapons of mass destruction.

The strategic opportunities are to

- expand our traditional roles and contributions through new technology development, systems integration, and greater partnering in vulnerability assessment to impact the full spectrum of national security issues;
- monitor technologies to support applications from cooperative monitoring to remote sensing in denied areas;
- develop advanced technologies and systems for weapons storage and management of special nuclear materials;
- expand incident response capabilities; and
- interact with other DOE Defense Program activities to influence evolving stockpile requirements.

## Energy and Environment

Sandia's Energy and Environment Sector will support its customers in DOE, other government agencies, and US industry by contributing effective science and engineering solutions that improve our national energy security and the quality of our environment. We will provide managerial and technical leadership to resolve issues of national importance and impact. We will apply the full range of our engineering capabilities and scientific foundations toward delivering quality products to our customers. We will strengthen and expand our established responsibilities in energy research, fossil energy, renewable energy, nuclear energy, nuclear waste management, and environment. We will integrate these responsibilities into the larger context of sustainable development. We will establish leadership in emerging responsibilities with our customers, and we will provide the basis for DOE to identify and move into new areas of vital national concern.

### Energy

Sandia will identify, develop, and help deploy full systems solutions for safe, clean, and affordable energy options that enhance the security of the nation and reduce global tensions over sources. We will: improve manufacturability and reliability of alternative energy systems; develop efficient technologies for utility, industry, and automotive applications; provide leadership in applying advanced technology to the oil, gas, and geothermal industries; and establish the technical basis for safe, effective, nuclear energy systems.

### Environment

Sandia will develop affordable and deployable environmental technologies that enhance environmentally conscious operations in industry, help remediate contaminated DOE sites, and solve the problems associated with disposal of radioactive wastes. We will: exhibit leadership in providing technology for clean industries; advance technology for contributing to DOE's environmental cleanup; develop viable solutions for nuclear waste storage, transportation, and disposal; and support DOE and national environmental, safety, and health efforts.

### Work for Others

The Work-for-Others (WFO) Sector will utilize distinctive Sandia capabilities and Sandia's special independent status as a national laboratory to provide trusted, honest, objective, science-based solutions for problems of enduring national importance to other agency customers.

The WFO Sector will add value for non-DOE customers by providing integrated solutions that combine innovative systems concepts with our enabling technical skills in manufacturing, electronics, and information sciences. The results will be practical solutions that significantly extend existing capabilities and satisfy customers' operational needs.

The WFO Sector will strengthen and enhance the US industrial technology base, including the defense industrial base, by: sharing technology with and transferring technology to industry; selecting and emphasizing dual-use technology and programs; aggressively teaming with industry and other agencies to leverage technology from all sources; and emphasizing high-level cooperative development agreements between federal agencies and private organizations.

The WFO Sector will become a catalyst for precompetitive research and development alliances with industry, universities, and users. The sector will establish Sandia as the leading proponent and creative implementer of effective mechanisms for establishing government/private partnerships to address important national problems.

The WFO Sector will strengthen and enhance Sandia's ability to continue serving DOE missions by emphasizing and selecting programs that synergistically nurture Sandia's core competencies while satisfying critical needs of other customers. The sector will establish project selection and investment/disinvestment criteria that strategically position WFO work into four areas:

- Direct support of nuclear weapons (safing, arming, firing, and fuzing systems).
- Work related to the nuclear mission, such as



---

counterproliferation and munitions research and development. In particular, we will work through DOE to apply nuclear weapons program skills, capabilities, and facilities to DoD's responsibility for developing counterproliferation technologies against weapons of mass destruction.

- Work that directly supports Sandia core competencies, such as high-performance computing and information technology components manufacturing.
- New initiatives that draw upon Sandia's core competencies and prepare the laboratories to address emerging national needs such as biomedical engineering and transportation systems.

## Core Competencies

Sandia's objective is to sustain and stabilize our core competencies (research foundations and integrated capabilities) and to ensure the capability for attracting and developing the best research talent in the required disciplines.

Sandia's core competencies are a product of its forty-year heritage as a premier research and development laboratory. They are crucial to our ability to provide solutions to the nation's challenges in defense, energy security, environmental integrity, and industrial technology.

Science-based engineering is essential for leadership in technology. Engineering practice advances most rapidly when it is exposed to new principles and techniques derived from scientific discovery through engineering research.

The core competencies are a matrix of research foundations and integrated capabilities, and they make science-based engineering and product realization possible. The research foundations derive scientific and engineering principles. Those principles are used to advance the integrated capabilities that are crucial to Sandia's programs, both today and tomorrow.

## Research Foundations

Sandia has four multidisciplinary research foundations:

- engineered processes and materials,
- microelectronics and photonics,
- computational and information sciences, and
- engineering sciences.

These provide the scientific knowledge base upon which Sandia's integrated capabilities depend. Our management

philosophy for the research foundations is based on the guiding principles below.

The four research foundations will be managed for the benefit of Sandia's sectors and strategic thrusts. Our goal is to ensure that the research foundations provide the science and engineering wellspring from which we draw the ability to meet our customers' needs.

We will accomplish this goal by establishing broad research programs that anticipate the needs of Sandia's sectors and strategic thrusts and by actively managing the programs to ensure that they adapt to changes in those needs. We will also encourage movement of personnel across division boundaries to promote the diffusion of new technologies and strengthen the ties between the research foundations and the sectors and strategic thrusts.

Sandia will achieve technological leadership in each of the four research foundations. Our goal is to be recognized and valued, both internally and externally, for our contributions and leadership in research and technology development in these areas.

We will achieve this goal by establishing high-impact, leading-edge research and technology development programs that are scrutinized by external peer review. We will continue to recruit and develop world-class technical staff with a diversity of backgrounds and expertise, and we will recognize and reward their technical excellence, creativity, and leadership.

We will be sensitive to the resource constraints imposed by the current fiscal environment. Our goal is to be conscientious stewards of the resources provided for the advancement of our research foundations.

We will accomplish this goal through the use of sound business practices that result in maximum leverage of our resources. We will exercise every opportunity to establish research programs that lead to the development of dual-benefit technologies. Sandia research programs will actively seek partnerships with universities, industry, and other federal laboratories to take advantage of advances made elsewhere and to transfer technology to the commercial sector.

## Integrated Capabilities

Sandia has four integrated capabilities:

- advanced manufacturing technology,
- electronics technology,
- advanced information technology, and
- pulsed power technology.

These integrated capabilities are advancing technologies that derive their scientific basis from the research

---

foundations. All these technologies are important to current direct programs at Sandia. They are also strategically important for future Sandia programs and for technology development in the private sector. In this context, they are sometimes called strategic thrusts, especially when their long-range importance to Sandia and the nation is being stressed.

### ***Advanced Manufacturing Technology***

We will provide technology and leadership in advanced manufacturing to make continuing, critical, and valuable contributions to our nation's defense, economic competitiveness, environmental stewardship, and energy security.

This thrust will directly support Sandia's expanded responsibilities for production of nonnuclear components as the nuclear weapons complex is restructured.

### ***Electronics Technology***

By leveraging Sandia's research foundation in microelectronics and photonics, we will: apply our electronics technology to enhance the safety, security, and use-control of nuclear weapons; make continuing contributions to defense, including new technologies to discourage the proliferation of weapons of mass destruction; and expand our contributions to the nation's economic security by targeting major needs in commercial technology. Through cooperative work with industry and universities, our integrated capability in electronics technology will enable Sandia to maintain a state-of-the-art electronics technology base and provide value to industry.

### ***Advanced Information Technology***

We will provide information-based technology for challenging national problems. We will also provide differentiating expertise in information technology and systems to weapon programs, related mission programs, other strategic thrusts, and national information initiatives.

### ***Pulsed Power Technology***

We will maximize the benefit of our leadership position in pulsed power by applying Sandia's leading-edge pulsed power accelerators to problems of national importance with other DOE laboratories, US industry, and universities. We will provide large volumes of very-high-energy densities for DOE Defense Programs in nuclear weapon physics, radiation effects science, and inertial confinement fusion in the laboratory, a particularly important capability in the absence of underground nuclear testing. We will apply our efficient, high-average-

power sources of electron, ion, and x-ray beams to defense-related missions of materials hardening, environmental remediation, and materials welding and joining. In partnership with industry and universities, we will also apply these capabilities to commercially valuable applications in materials surface modification, electronic pasteurization of food and pharmaceuticals, sterilization of medical instruments and medical wastes, and repetitive electromagnetic force.

### **US Industrial Competitiveness**

Sandia's objective is to make measurable contributions to the global technology leadership of US industry. We will institutionalize the interaction of all Sandia programs with appropriate industry elements, promote the national laboratories' role as a bridge from research to application in collaboration with universities and industry, and achieve permanent mission status for a DOE laboratory role in supporting US economic competitiveness within five years.

We will seek strategic alliances with industry, universities, and other laboratories to pursue industry-defined research and development objectives. These alliances will be mutually beneficial to the sponsoring DOE program and the industrial partner. They will benefit Sandia by permitting us to incorporate the most current commercial technologies into DOE products. They will help industry by fostering the development of new or improved products and services based on US technology leadership. This work will include new ventures that promote private entrepreneurial activity, which in turn should create new jobs.

Our strategy for collaborative research and development will continue to emphasize large-scale alliances with industry and universities. We will form teamwork arrangements with clusters of companies in which the capabilities of DOE, industry, and universities are combined to develop enabling technology for an industry. We will fully support DOE's efforts to create alliances with other federal agencies utilizing the capabilities of the national laboratories.

Sandia recognizes the role played by small business in fueling the nation's economy. We will employ a three-pronged approach to support small business growth and development. Specifically, we will form technology development partnerships with small business through the use of cooperative research and development agreements and similar arrangements. We will deploy existing technology by taking advantage of networks such as the manufacturing extension centers. We will also encourage entrepreneurial activity through alliances with organizations such as the newly formed Technology Ventures Corporation.

Sandia's user facilities will be increasingly important

as vehicles for generating cooperative work with industrial partners and for building alliances involving industry, university, and government entities. User facilities help industry obtain maximum benefit from technologies and capabilities developed at Sandia. Research and development conducted in these facilities can satisfy a broad spectrum of dual-benefit needs for government and industry. User facility advisory groups, networks, and cooperative working groups will increase collaboration among industrial, university, and national laboratory participants.

To facilitate collaborative work with industrial and university partners, access to Sandia sites will be made more user-friendly. The fact that Sandia's largest technical area is located on a military installation can make it awkward for partners to do business with us. Visitor access to the New Mexico site will be improved by establishing a DOE-controlled entrance at Eubank Boulevard and constructing a visitors' center and making other improvements. Changes in site layout are likely to affect classified and unclassified business areas, traffic circulation, parking, and other infrastructure.

Visitor access to the California technical area will also be improved through changes in campus infrastructure. Sandia/California's proximity to the high-technology industrial and academic centers of the West Coast will continue to be a strategic asset for the entire laboratory. The California site will increasingly serve as a gateway to Sandia's laboratories.

A significant investment will be required to perform this site conversion work to improve the logistics of working closely with industry on national, industry-led initiatives.

Sandia excels in creating new technical information. New technology, however, is only one ingredient in new products and services. Industry also needs intellectual property protection in order to attract the risk capital needed for commercialization. Sandia will continue to increase its capacity to identify and protect intellectual property. We will progressively increase the number of Sandia patent applications filed per year over the next several years.

Our collaborative work should so please industry, and its economic impact be so tangible, that it becomes a primary mission of its own, rather than incidental to established DOE missions. This activity should be block-funded, rather than supported piecemeal. Such a strategy supports DOE's commitment to industrial competitiveness as a core business area of the department. It is DOE's goal to "establish DOE as industry's research and development provider of choice in its areas of scientific and technical competency."<sup>1</sup>

## Sandia Production Responsibilities

Sandia's objective is to assume new production responsibilities as requested by DOE to support the stockpile's need for an ongoing, low-volume supply of certain nonnuclear components.

Sandia has been assigned several new production responsibilities that complement the integrated capability in advanced manufacturing technology ongoing at its New Mexico and California locations. The closure of DOE's Pinellas and Mound facilities will result in Sandia taking on responsibility for the production of small quantities of neutron generators and other specialized components. It will also be Sandia's responsibility to manage production procurements for components available in industry and needed for DOE's stockpile stewardship mission.

Further, Sandia has been requested to supply the pharmaceutical industry with sufficient quantities of molybdenum-99 to satisfy the US requirement for this radiological diagnostic material.

This emerging production responsibility, which is an important new customer requirement for Sandia, represents an opportunity to complement our advanced manufacturing integrated capability and establish a test bed to prove developments in manufacturing technology before introducing them to industry.

## Operational Objectives

### Quality

Sandia's objective is to live up to our commitment to total quality through customer satisfaction and continuous improvement in our research and engineering, our products and services, and all our work processes. We will become world-class in our ability to satisfy and delight our customers as measured by the Malcolm Baldrige criteria.

Success and survival for Sandia in the 1990s will require an efficient, quality enterprise. The next phase of the quality implementation at Sandia will require reengineering and simplifying work processes so Sandians can perform their jobs with less encumbrance and greater leverage. Work practices should be logical and relevant to real program or administrative requirements.

Sandia's work processes will be managed as an integrated system. As a general rule, continuous improvement is an effective tool for keeping processes useful and efficient. However, when processes become so complex or obsolete that they cannot be substantially improved through incremental changes, comprehensive redesign is required.

<sup>1</sup>US Department of Energy, *Fueling a Competitive Economy: Strategic Plan*, April 1994: p. 13.

---

A laboratory process reengineering campaign will begin by examining several critical categories of laboratory processes and recommending fundamental changes. A modern information and communications infrastructure will be an enabling tool for process improvements in all areas.

## Business Management

Sandia's objective is to achieve outstanding business management in all our administrative systems. We will strive to meet DOE's expectations for excellence in management practices and operate Sandia in accordance with best business practices to strengthen DOE's confidence in Sandia as a well-managed organization.

The DOE Strategic Plan identifies management practices as a critical success factor.<sup>2</sup> It has become clear that the federal government will insist on more cost-effective operation of federal research and development facilities. Cold War practices, which emphasized performance at any cost, are not appropriate in a new era that requires the DOE laboratories to interact with a private sector that measures performance by industrial standards of efficiency.

We will incorporate proven business practices from our parent organization, Martin Marietta Corporation, to improve Sandia's management and operation. The business leadership of Martin Marietta will be an important resource as we strive to improve our administrative systems and emulate cost-effective practices of the private sector. We will benchmark our administrative systems against those of industry to identify areas for improvement. In addition, we will promote best business practices in the DOE contractor community and share business systems with other laboratories.

We will improve and more fully utilize the matrix management model for performing work. The sector/division matrix that currently exists will be better exploited for that purpose. Under this structure, the sectors, driven by customer requirements, manage programs and determine what work must be done and by what schedule. Functional organizations direct the personnel and facilities required to perform work and are held accountable for meeting their commitments to sectors. Sectors will define an explicit set of external customer interfaces. Functional organizations will focus on improving work processes and employee skills. Program managers and functional managers share responsibility for customer satisfaction.

Sandia will maintain an in-house capability for the research and development activities essential to its DOE missions and will develop the emerging capabilities that

are anticipated to be essential. Other capabilities may be outsourced to the extent it makes business sense to do so. As a general rule, we will focus Sandia's internal investments on value-added, mission-related capabilities that are not readily available commercially or from other government sources.

As we embrace our production responsibilities, both for DOE's Defense Programs and for other elements of DOE, we will structure and conduct the production aspects of our work in a manner appropriate for a production enterprise. We will continue to evaluate the proper relationship of our production activities to the laboratory as a whole.

We will operate our New Mexico and California sites as a single laboratory joined by common management policies, operational principles, and state-of-the-art telecommunication systems. We will reengineer work processes and systems that need fundamental retooling in order to integrate the two sites even more fully in the future. Because of its compact size, the California site will be a good environment for pioneering and prototyping new laboratory operational systems.

We must strive to achieve compliance with DOE directives. A graded approach to compliance based on risk management principles may be helpful in minimizing the impact on mission capabilities. In cases where DOE directives impose costly or ineffective processes, it is in the interests of DOE and Sandia to examine the requirements of the directive and propose an alternative that can achieve the intent more effectively and efficiently. The DOE Directives Improvement Project, a joint effort of DOE and its laboratories, has been very successful in reducing onerous and inefficient directives. This team effort should continue as we work with the recently established DOE Directives Management Board in the future.

DOE is one of Martin Marietta's most important customers, representing a core business area of the corporation. We will strive to reflect credit on our parent organization through exemplary programmatic performance, high ethical practices, and faithful execution of our contract obligations.

## People

Sandia's objective is to achieve mission success through talented, diverse people working in agile teams. We will encourage a work environment in which every employee has the opportunity to achieve personal success. We will manage staffing levels prudently to provide for current and future programmatic and institutional needs. We will also be a good corporate citizen by supporting the economic vitality of our communities and encouraging community involvement by Sandians.

Our human resources policies must provide the

---

<sup>2</sup>ibid: p. 34.

---

people and skills best suited to support DOE missions in a timely manner. To compete nationally for outstanding technical staff, we must offer challenging scientific and engineering assignments with civilian as well as military uses. Support staff will be recruited to meet national standards of education, experience, and professional certification (if applicable). Successful human resources management will help Sandia achieve its long-term programmatic goals within the context of changing work requirements and evolving demographic and societal trends.

Management of human resources at Sandia is consistent with DOE's strategic goals for attracting a well-trained and highly motivated work force and achieving a diversity that reflects American society. We will aggressively implement our human resources plan, one that enhances the ability of our staff to match their interests and skills to Sandia's work commitments. As work requirements change, we will provide employees the opportunity to grow and to assume responsibilities in new fields of endeavor.

The challenge of helping the nation accomplish some of its toughest objectives requires not only the best minds but also the broadest vision—being able to see issues and possible solutions from many different angles. The imperatives surrounding diversity in the workplace include developing a high-performing, diverse work force that appropriately reflects society as a whole, and developing an inclusive culture that fosters such a work force by embracing differences. In addition, the integration of work force diversity with education outreach, community involvement, subcontracting, and technology transfer will enable us to take a more global approach to achieving our goals.

Sandia will continue to foster a culture in which people are empowered to achieve the business objectives of the laboratories. Each person must understand the connection of what he or she does to the success of the business and assume ownership for improving the processes he or she performs.

We will be responsive to people's needs and practice our values in the workplace. The performance management and reward systems will be designed to reinforce these values. We will foster a work ethic that strives for excellence and incorporates a balance between professional and personal goals and responsibilities. Criteria for promotion and reclassification will consider people-related work skills as well as technical excellence. Career development and succession planning will also become responsibilities of line management.

It is Sandia's policy to foster a progressive and productive relationship between labor and management. This will be accomplished by maintaining an open environment for communication and establishing partnerships between management and bargaining units to enhance the utilization of the talents and abilities of represented employees in supporting Sandia's missions. We will

resolve issues at the lowest possible level quickly and effectively.

We recognize that stability and continuity are essential for sustained excellence in a research and development environment. Instability in staffing can impair employee morale and productivity. We will try to avoid staffing instabilities through prudent business management and by utilizing retraining and redeployment opportunities wherever possible.

A good corporate citizen is responsible and responsive. As a responsible business, we are committed to meeting the needs of our programs today without compromising the welfare of future generations. Being responsible also means respecting our community—its values and culture as well as its quality of life. As a responsive business, we will listen and respond to the needs and concerns of our community to enable a partnership in maintaining the community's quality of life. The foundation of good citizenship is mutual trust built on communication and cooperation.

## Environment, Safety, and Health

Sandia's objective is to maintain our enduring commitment to protect the safety and health of all Sandians and visitors to our sites. We will be a good corporate citizen by protecting the environment wherever we conduct operations.

Our strategy for protecting safety and health in the workplace and the community and preventing adverse impacts on the environment will be based on a methodology to achieve maximum environmental, safety, and health (ES&H) benefit cost-effectively. We will perform a comprehensive identification of ES&H risks associated with our operations and address those risks in a graded manner. In this way, optimum value can be delivered for the resources expended.

Teamwork among employees, customers, suppliers, and community representatives is essential to successfully protect the environment and guard personnel health and safety. Sandia will continue to apply total quality management principles for all ES&H activities. In addition, open, timely communication of ES&H concerns, lessons learned, plans, and status will help assure appropriate and uniform actions throughout all Sandia operations.

Sandia's environmental restoration program will address environmental problems in a timely fashion, thereby maintaining public confidence in our ability to conduct operations without harming the environment.

## 5 • Major Initiatives

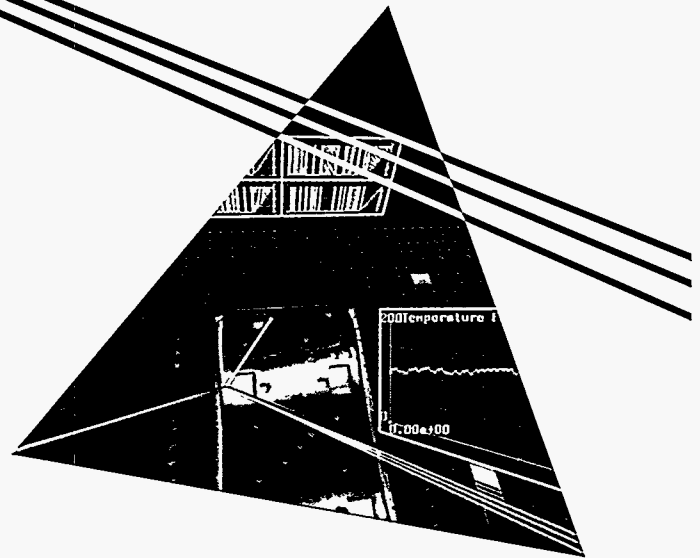

This chapter presents initiatives for consideration by DOE or reimbursable sponsors. Three of Sandia's major initiative areas are also core competencies:

- advanced manufacturing technology,
- electronics technology, and
- advanced information technology.

These core competencies contribute to the integrated capabilities required for DOE's defense, energy, and environmental programs. They represent established roles for Sandia, and they enable other program contributions and major initiatives. Sandia's general effectiveness is continuously enhanced by pursuing progress in these areas.

Sandia has also identified five major programmatic initiatives or focus areas. Focus area initiatives extend integrated capabilities to new or emerging programmatic objectives. Focus area initiatives, which are defined by the intersection of large-scale, strategic national needs and established laboratory capabilities, include

- Transportation Energy Technology and Infrastructure,
- Environmental Technology,

- Energy Research and Technology Development,
- Biomedical Systems Engineering, and
- Post-Cold War Defense Imperatives.

These focus area initiatives are logical applications of our experience base and core competencies. None will require Sandia to acquire costly new competencies that have not historically been related to its missions. All offer opportunities to address strategic national needs cost-effectively by exploiting the existing federal investment in Sandia's core competencies.

Our strategy for implementing all of our major initiatives, both integrated capabilities and focus areas, is fourfold:

- We will continue to enter into cooperative research and development agreements with individual companies to help them address their proprietary needs.
- Project proposals may either respond to market-driven needs defined by industry or introduce novel technologies that have the potential for new classes of commercial applications.

- As much as possible, all work will include a high degree of collaboration with industry, universities, and other federal laboratories through cost-sharing arrangements.
- We will help support the research and development needs of small and mid-level businesses through special cooperative arrangements and technology outreach programs.

Some projects may not be able to utilize this strategy if they involve classified national defense work. However, even in those cases we will attempt to exploit commercial capabilities to the extent possible. We will diligently identify dual-benefit possibilities and help industry take advantage of them.

In the subsections that follow, we will discuss the established capabilities, experience base, and laboratory strengths that make Sandia a valuable and perhaps unique resource for each major initiative. Also, each major initiative discussion presents a package of project proposals for new work or major program enhancements. Funding and staffing requirements for these proposals are in addition to the ongoing programmatic funding summarized in chapter 13.

The inclusion of a particular project proposal under a major initiative does not imply DOE approval, nor does it represent a commitment by Sandia to implement it. However, each initiative represents a strategic commitment on the part of Sandia management. Each derives its technologies from Sandia's established core competencies and is an activity in which Sandia is acknowledged to have made substantial contributions or significant recent progress. Moreover, these major initiatives are intended to implement long-term national and agency goals.

## Advanced Manufacturing Technology

As a consequence of its responsibilities in systems and design engineering, production process development, intelligent machine research and development, and oversight of the performance and reliability of nonnuclear weapon components over the last forty years, Sandia has become the leader among DOE laboratories for advanced manufacturing technologies. Manufacturing support technologies are central to our mission for DOE Defense Programs and constitute a large fraction of our technology base.

The problems facing the DOE nuclear weapons complex presage those that will be faced by the US manufacturing community as a whole. The future operating environment will require manufacturing agility and cost-effectiveness. We will have to design and manufacture to the highest standards of quality. Production will have to occur in an environmentally conscious

manner. The nuclear weapon laboratories must continue to design for the total life cycle, including retirement, dismantlement, and disposal or recycling of components and materials. As a form of deterrence, the complex will need to demonstrate the capability to get new designs into production quickly. The complex must be able to create designs with a minimum of iterations and validate production processes through simulation. Central to achieving these objectives will be an effective information communication and management system that integrates the design-to-production-to-disposal process using teamwork to allow concurrent activities.

DOE cannot accomplish this mission in isolation from the nation's manufacturing community. Conversely, the manufacturing community stands to benefit from DOE laboratories' research and development in manufacturing.

The National Center for Advanced Manufacturing Technology has been established at Sandia/New Mexico to maximize the value of Sandia's technology base to the manufacturing needs of both the DOE nuclear weapons complex and industry. The center will coordinate its efforts with other government agencies and laboratories, universities, and US industry to ensure maximum value to the nation. The center will also help transfer and apply advanced manufacturing technologies developed in Sandia's defense programs to commercial manufacturing, helping to strengthen US industry's competitiveness. Much manufacturing technology transfer is already taking place through many cooperative research and development agreements with industry.

Sandia's California location is strategically important to our advanced manufacturing initiative as a point of contact with the high-technology industries of the West Coast. The new Integrated Manufacturing Technologies Laboratory focuses on the development and integration of advanced manufacturing technologies. It conducts research and development in materials and processes, process simulation, engineering design, and manufacturing technology support. It also performs research in prototype fabrication and demonstration techniques for agile manufacturing, both for DOE and the domestic industrial sector. Current work focuses on metal removal and welding, weld process simulation, composites fabrication, high-speed communication of manufacturing data, and on-line monitoring and control.

Many of these activities and initiatives will leverage our knowledge in much the same way that machines leverage muscles. Because this initiative cuts across all of Sandia's technical capabilities, activities that are of direct value to and supported by advanced manufacturing also appear in other major initiatives. Examples include the recently established National Center for Advanced Information Components Manufacturing, a partnership involving the Advanced Research Projects Agency, DOE, and industry. Industry requires further developments in the manufacturing of optoelectronics and flat-panel displays. This work will be enhanced by activities under

---

Sandia's other major thrusts (i.e., Electronics and Advanced Information Technology and the defense-related initiatives intended to make the nuclear weapons complex a model of agile manufacturing).

## Project Initiatives

### **Information-Driven Manufacturing**

*(for the Assistant Secretary for Defense Programs [program GB])*

Information technology is a means of achieving the objectives of the modernized DOE Defense Programs design and production complex and of enabling an economically competitive US manufacturing infrastructure. Future DOE manufacturing systems will depend heavily on a range of computing tools, from design at a work station to real-time computer control of individual production processes.

Recent research and prototyping work at Sandia has demonstrated feasibility of very tight coupling of design and production processes. Application-specific development of information technologies such as networking and computer science, design analysis, data processing and storage, information surety, and intelligent production systems, processes, and equipment is required for the nuclear weapons complex.

DOE weapons designers have long used computers to design products, manage and process data, and analyze the performance of their designs. Now these methods are being extended to analysis of the producibility of designs, to assessment of the environmental consequences of designs, and to automated generation of the controls and programs used by the factory production systems. Information technologies will permit designs to be validated in virtual factories before they are approved for release.

In a likely scenario of future manufacturing, designs will be created at computer-aided design workstations and their performance evaluated by integrated computational tools. The same electronic design information will then be coupled with computer models of production processes developed through simulation and limited experimental validation. These models will be available to product designers for assessment of various producibility issues. This process/product assessment is termed manufacturing validation in current literature. Once designers are satisfied with the design, control algorithms for production equipment are automatically generated using the product design database and the computer model of the process. Automated programming of production equipment will be an important element of agile manufacturing. In turn, the plant model permits real-time control of the process based on information sensed from process and product.

Such manufacturing systems will make heavy use of information sciences and technologies; consequently, we use the term information-driven manufacturing. Information-driven manufacturing technologies will make possible many of the desired attributes of DOE's nuclear weapons complex. Weapon system designers will be able to determine quickly if their designs are manufacturable with the available production systems. Production agencies will be able to remove workers from hazardous operations and, in the process, reduce waste resulting from contaminated protective clothing. Furthermore, because much of the design and production expertise will be embodied in algorithms and software, the cadre of trained engineers and technicians required to operate the complex will be reduced without degrading the ability to respond to national emergencies. These assertions are based on a review of Technology Assessment and Selection Panel documents and discussions on future needs for robotics and automation with panel leaders and managers of the DOE production agencies.

Sandia and DOE will retain a leadership position in information-driven manufacturing as a result of this initiative. These technologies are key elements of US industrial initiatives in agile and intelligent manufacturing.

### **Industries of the Future**

*(for the Assistant Secretary for Defense Programs [program GB], the Assistant Secretary for Energy Efficiency and Renewable Energy [program ED], the Assistant Secretary for Environmental Restoration and Waste Management [program EW], the Assistant Secretary for Energy Research [program KC07], and the Assistant Secretary for Fossil Energy [programs AA, AB])*

The challenges faced by US industry in the increasingly global, rapidly changing marketplace that has developed at the end of the twentieth century are well recognized. The strategies developed to meet these challenges will be conditioned by the requirements of environmental responsibility and constraints imposed by uncertain access to energy resources, as well as by the cost and time-to-market demands of the evolving world market. Technologies that simultaneously address the challenges of economic competitiveness, energy, security, and environmental quality will form the foundation of the emerging manufacturing infrastructure.

This initiative will employ an integrated, interactive partnership. Integration of government activities and programs will reduce duplication of efforts, leverage investments, and obtain the maximum impact possible. Interaction among government agencies and between industry and government will ensure the development and deployment of technologies that contribute to industry profitability while satisfying federal environmental regulatory requirements. Partnerships or strategic



alliances of industry, government, and academia will provide the facilitating mechanisms for technology development and deployment and will ensure that the outcomes of this initiative provide significant benefits to all parties. The primary steps necessary for the effective implementation of this initiative are (in temporal order): formation of strategic alliances; identification and prioritizing of critical national needs; identification of routes to success; assignment of authority and responsibility for implementation; and development, demonstration, and deployment of new processes and products.

Successful implementation of this initiative is expected to contribute to the fulfillment of national agendas in economic competitiveness, environmental quality, and energy security. Capture of additional market share by US companies should help the United States reduce its trade and budget deficits and create new jobs. Waste reductions and energy savings will contribute both to reduced costs of goods and to improved quality of life for Americans. Increased industry profits through lower energy costs of goods and enhanced agility leading to the capture of larger market shares will improve our economic climate. Finally, the training our academic institutions will provide through their participation in this initiative will yield a higher quality work force more able to undertake the high-value-added jobs that will make significant contributions to future US economic well-being. Through its focus on industries of the future, this initiative will substantively enhance the value of the US manufacturing sector.

### ***Environmentally Conscious Manufacturing***

*(for the Assistant Secretary for Defense Programs [program GB] and the Assistant Secretary for Energy Efficiency and Renewable Energy [program ED])*

Environmentally conscious manufacturing (ECM) is the deliberate attempt to reduce the ecologically harmful by-products of industrial processes and improve energy efficiency without sacrificing quality, reliability, or performance. ECM technologies and practices optimize manufacturing process decisions about cost, resource utilization, environmental impact, and product reliability and performance. The end result of ECM is a value-added transformation of materials and energy into products in a manner that adds environmental considerations to the manufacturing process.

Successful implementation of environmentally conscious manufacturing requires a total systems approach to very complex problems utilizing engineering, chemistry, information systems, reliability and risk analysis, life-cycle analysis, and advanced manufacturing.

Sandia has led the way in practical application of environmentally conscious manufacturing through an

integrated systems approach for implementing ECM processes and demonstrating the benefits of ECM in DOE programs. In the past, application of a fully integrated approach has focused on weapon components, including prototyping systems, providing analysis tools, and coordinating the first ECM demonstration in the DOE nuclear weapons complex (electronics and electromechanical component fabrication at Allied-Signal in Kansas City).

Over the next five years, Sandia will bring the benefits and techniques of ECM to US industry.

We will develop and demonstrate ECM methods and technologies with high dual-benefit payoff. Sandia will develop methodologies for easier ECM implementation, such as expert-system decision tools to allow consideration of environmental impact in product design and manufacturing process decisions. Sandia will collaborate with the Environmental Protection Agency (EPA) to refine prototype life-cycle analysis tools. We will test ECM's feasibility and complete its development into a user-friendly tool for industrial use. We will evaluate available technologies for ECM, identify technology needs, and initiate programs to develop and provide new ECM technologies that have been fully tested and validated (e.g., advanced soldering and cleaning techniques).

We will concentrate on the application of ECM through collaborative programs with partners from US industry and other government agencies.

We will develop industry-driven collaborative programs in ECM with the goal of a track record of successful government/industry technology transfers. These programs will emphasize active solicitation of industry's needs, measurement of our effectiveness in meeting those needs, effective dissemination of information on ECM to industry, and identification of opportunities for transfer of industrially developed technologies to the defense complex.

New approaches will be used in these programs, including expanded use of industry advisory groups and market research, adoption of performance metrics accepted by industry, and more active collaboration with industry trade associations for opportunity assessment and information dissemination. We will expand the present work in transferring technology to the microelectronics industry and extend it to other industries (e.g., textile, automotive, chemical, pulp, and paper) with modifications as appropriate. These Sandia programs will cover technologies such as the following: solvent substitution; soldering (no-clean, lead-free, and advanced technologies); polymers engineered for reuse/recycle; "green" printed wiring board fabrication; advanced process monitoring and control; and replacement of hazardous materials in surface coating, metal finishing, and precision machining.

We will initiate new multiple agency collaborative programs, especially with the EPA and the Department of

---

Commerce (DOC), to more effectively address regulatory and technology transfer issues. Programs have been proposed to integrate EPA and DOE techniques for process waste assessment and environmental and energy audits into a single assessment tool. We will collaborate with the EPA and DOC through the Manufacturing Technology Centers of the National Institute of Standards and Technology to evaluate the impact of new ECM processes to make ECM benefits more visible to all US industry. We will coordinate with other DOE offices and DoD to eliminate redundancies and ensure that ECM technology development is applicable throughout the complex.

We will establish Sandia as a national ECM resource by evaluating our current capabilities and developing them accordingly. We will survey commercial ECM resources and develop programs in which Sandia can serve as a focal point, referencing and collaborating with manufacturers to add the ECM dimension. This work will increase emphasis on Sandia as a single provider of ECM technology, including evaluation of alternatives, development, feasibility demonstration, assistance in deployment, and dissemination of information.

New programs will be initiated to focus on coordinating state and federal resources to deploy ECM technologies to industry, particularly small businesses. An example is a proposed joint DOE/EPA/DOC Environmental Extension Enabling Program in which Sandia will work with extension entities of the National Institute of Standards and Technology to identify small business needs. We will help develop and commercialize technologies and facilitate technology deployment by training and providing advisors for the National Institute of Standards and Technology, state extension agents, and small businesses. New programs will focus on developing a complete on-line ECM knowledge base and an electronic ECM-information-on-demand network, improving ECM education (via a teaching factory at Sandia and simulation tools for retraining practicing engineers), and increasing effectiveness of ECM information dissemination through an extensive outreach program that includes a speaker's bureau, videotapes, joint activities with industry trade groups, workshops and exhibitions, and a widely distributed Environmentally Conscious Manufacturing Newsletter.

### ***Advanced Materials and Manufacturing Technology***

*(for the Assistant Secretary for Defense Programs [program GB])*

Two federal government initiatives, the advanced materials and processing initiative and the advanced manufacturing initiative, have emphasized the importance of materials research and technology development.

The intent of Sandia's advanced materials and manufacturing technology initiative is to work with industry to address its critical needs in the areas of materials synthesis and processing. A long-range objective is to improve the flexibility of manufacturing processes and facilitate the application of artificial intelligence to manufacturing operations by applying tools and concepts of concurrent engineering and computer-integrated manufacturing.

The reconfiguration of the nuclear weapons complex will require development of external industrial suppliers for a large variety of components. Low rates of weapon production and stockpile retrofits will require the design agencies to reduce costs for weapons research by developing and applying new materials and processing technologies. Such technologies will include computer design of advanced materials, computer modeling of materials processing, and development of sensors and real-time diagnostics for materials processing. These technologies can cut costs by accelerating the development of new materials and processes, and by reducing the need for prototype hardware. They will enable product design engineers to work concurrently with materials process engineers on component designs. They will permit more rapid prototyping by simulating and validating process options on computers, rather than on the factory floor. Moreover, such technologies will promote computer-integrated manufacturing by furnishing manufacturers with process controllers and process control software.

Planners of advanced materials and manufacturing technology have identified several specific activities for the initiative. These activities include the following: thermomechanical processing; electromagnetic synthesis and processing; development of sensors, process diagnostics, and smart materials; synthesis and characterization of optoelectronic materials; and synthesis, processing, and characterization of composite materials.

Interaction with industry will be facilitated by the recently established Advanced Materials and Processes for Economic Competitiveness alliance of Sandia, Los Alamos, the Air Force Phillips Laboratory, three New Mexico universities, and the New Mexico Economic Development Department, as called for in the DOE Laboratory Technology Partnership Act of 1992. Industrial interns will be centrally located at the Advanced Materials Laboratory in the University of New Mexico Research Park.

### ***Intelligent Manufacturing Science and Engineering***

*(for the Assistant Secretary for Defense Programs [program GB])*

DOE contractors have found that standard industrial robots, designed primarily for high-volume manufactur-

ing, have limited applicability to their operations, which typically call for small-lot production. However, with a modified approach to robotics research and development, intelligent manufacturing systems can be designed that are specifically applicable to DOE requirements but incorporate standard industrial robotic hardware. Such work will advance the capability of robotic tools available for agile manufacturing in industry.

Sandia's approach is to eliminate entirely the manual process of teaching and programming robots. We are developing algorithmic and software techniques that will let robotic systems generate their own programs. New systems based on these techniques will be able to generate plans of action, program the required devices, and use sensors and instrumentation to react appropriately to changes in the workplace. New sensor and model-based controls are obviating the requirement for precise fixtures and jigs for piece parts. Real-time sensory capabilities will permit flexible production systems to have other desir-

able features such as automated compensation for tool wear, in-process inspection, and automated error detection and correction.

The Intelligent Manufacturing Science and Engineering Project will draw upon Sandia's base of robotics technology expertise. During the past several years, Sandia has carried out robotics development for the Assistant Secretary for Defense Programs, the Office of Civilian Radioactive Waste Management, and the Office of Environmental Restoration and Waste Management. We are currently transferring robotic technologies to several DOE sites, including Pantex, Mound, Y-12, Savannah River, Allied-Signal, and Rocky Flats. Furthermore, we are consulting with several other organizations in the production complex and are performing research and development in advanced manufacturing for DOE mission applications.

In many ways, DOE's design and production activities are a microcosm of the future of commercial manufactur-

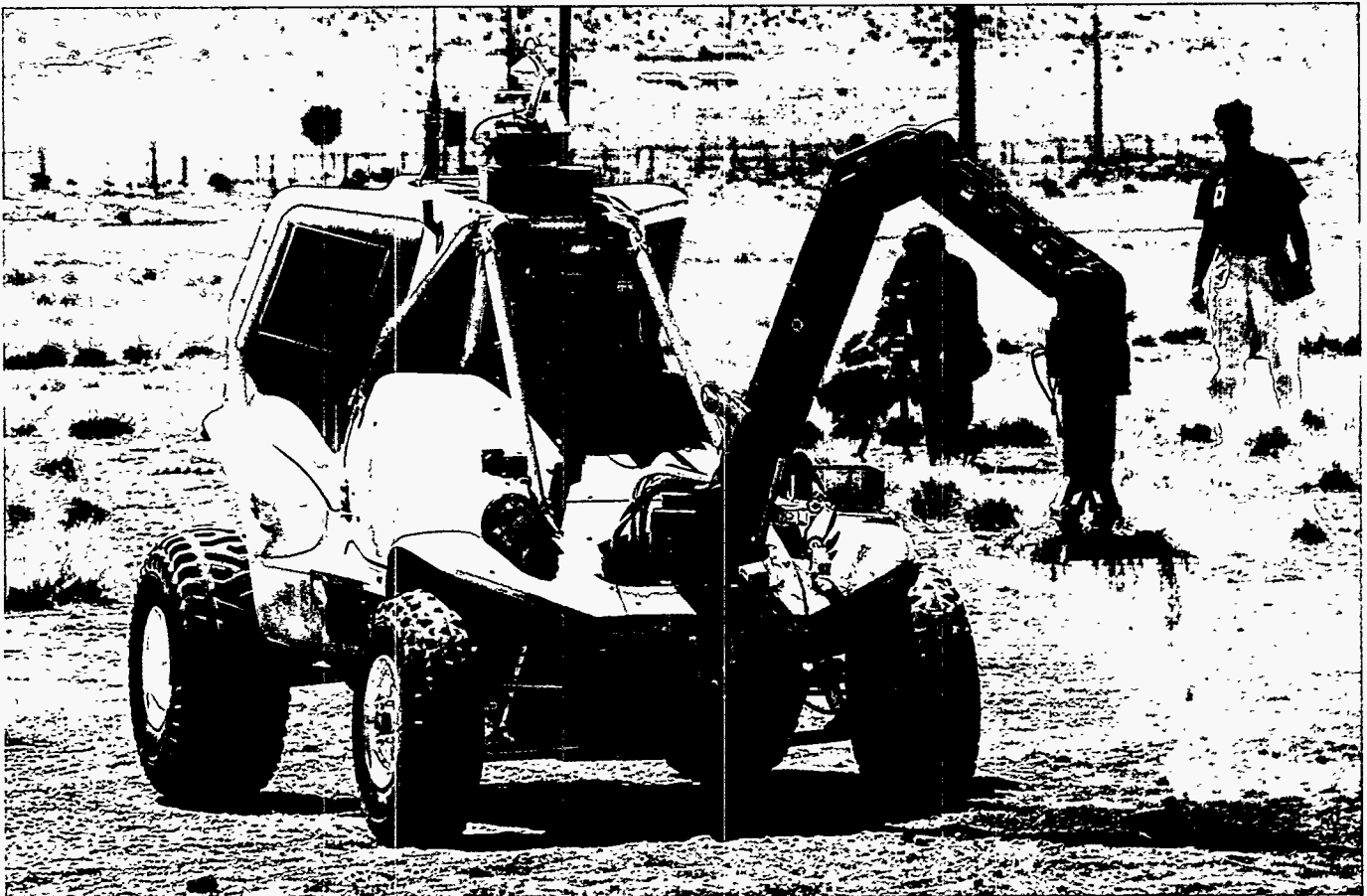

The remote Telerobotic Vehicle for Intelligent Remediation (RETRVIR) demonstrated its skills during the ground-breaking ceremony for the new Manufacturing Science and Engineering Laboratory. RETRVIR was developed by Sandia's Intelligent Manufacturing Science and Engineering Project.

ing. The Intelligent Manufacturing Science and Engineering Project will play a key role in reconfiguring and modernizing the nuclear weapons complex, and therefore offers an opportunity for DOE to help US manufacturers strengthen their competitiveness.

The initiative will push research in automated programming and planning, geometric modeling and reasoning, and high-speed, sensor-driven control—areas key to the broad application of robotics to DOE problems. In addition, we will construct prototypes of advanced systems targeted for specific applications within Defense Programs. Managers from across the DOE complex will be consulted regularly on the thrust and scope of developmental activities. Also, to facilitate technology transfer, engineers from the DOE production plants will help evaluate prototype systems. Sandia developers will continue active participation as full-scale production systems are built and brought into operation.

### ***Virtual Manufacturing Environments***

*(for the Assistant Secretary for Defense Programs [program GB] and the Office of Energy Research [program KC])*

The marriage of two of today's most advanced technology fields, virtual reality and advanced manufacturing, promises significant advances in the emerging discipline of virtual manufacturing. The virtual manufacturing environment will enable designers and others on a dispersed product realization team to interact with a wholly artificial environment constructed of design and simulation data. This entails sharing and manipulating high-fidelity simulations and three-dimensional computer-assisted design (CAD) systems in virtual reality space.

Advances in computer and display technologies have made possible the advent of virtual reality, a system that makes it possible for a human to feel immersed in a constructed environment consisting only of computer displays. In such a system, natural human senses can be fully utilized in exploring and understanding the data. In virtual reality space, sound and touch can be important displays that complement vision.

The most advanced system today is the multidimensional, user-oriented synthetic environment developed and patented by Sandia researchers. This synthetic environment is a flexible, modular, device-independent system that takes data or models and provides a highly interactive virtual reality environment in which to explore, examine, and manipulate a user's data. Data may be real-time or stored, and may be mapped to represent any variables that the user wishes to investigate.

Advanced manufacturing is characterized by the rational use of human and machine intelligence in the manufacturing process. The integrating factor among world-class manufacturing systems is information. Ele-

ments of advanced manufacturing include design tools, process and performance modeling and simulation, sensor-based processes, intelligent machines, automated assembly, and flexibility—which comprise what is sometimes called agile manufacturing. The communications linkages among all the elements of advanced manufacturing are amenable to visualization and simulation. By virtualizing every step of the product realization process, the concurrent team can design an optimal product, establish the most efficient (and agile, lean, and clean) manufacturing processes, prototype the most elegant software, exercise the simplest operational procedures, and set up the best implementing organization simultaneously, without ever hiring a person, building a factory, buying a machine, or making a physical part.

Virtual manufacturing environments, virtual reality, and advanced manufacturing converge in the new paradigm called the virtual interactive environment work space.

The virtual interactive environmental work space is the first application package of the multidimensional, user-oriented synthetic environment, and it contains many of the common features required to virtualize the product realization process. Two implementations are being developed: a single-user work station and a collaborative environment work space.

In single-station mode, the virtual interactive environment work space presents the designer or analyst with a virtual design office. If the site has virtual reality immersion equipment, the office will appear to be an actual room but will have information display and manipulation features that do not occur in physical space. If the work site has other means of display and interaction, such as two-dimensional screens or projection television systems, the same information and the same manipulation are still available, although total immersion will not be possible. A three-dimensional capability is not required; the virtual work space will work on any system that has the proper graphics and computational capabilities, independent of any hardware that inputs or outputs data.

The designer will be able to use voice commands and various input devices to request that all kinds of electronic data be brought to the design office and displayed there. For a typical designer of electromechanical products using a three-dimensional CAD system, products will appear as realistic as the local equipment allows. Simulations that predict the rigors of manufacturing and of real-world use will be available.

A powerful feature of the virtual interactive environment work space allows many geographically separated persons to meet, see each other, share information, and interact in a virtual meeting room. Each participant will bring along a private office not visible or accessible to others. In that private office, the participant will be able to access all kinds of data and to process and manipulate it privately.

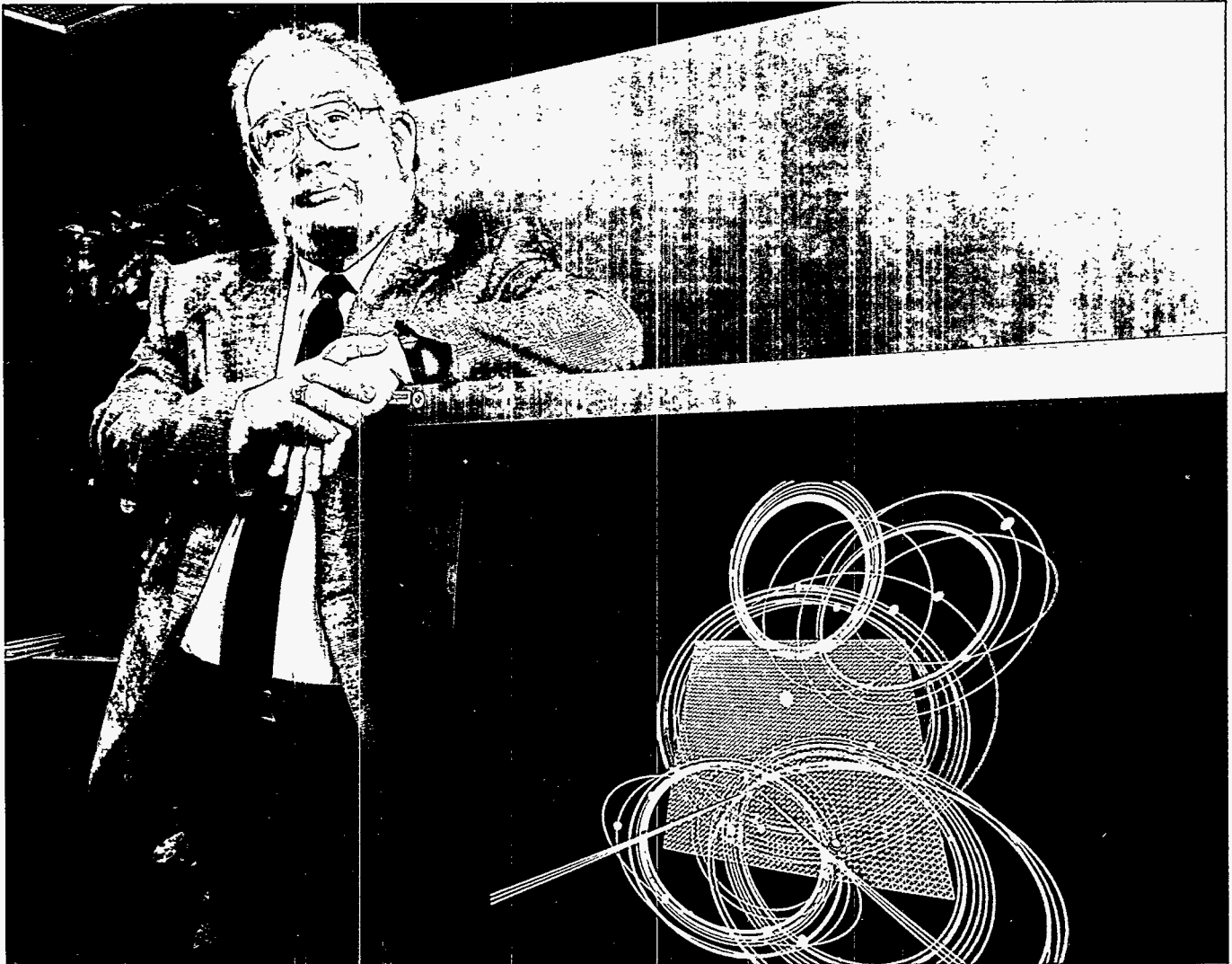

Sandian Creve Maples stands by a monitor displaying the solar system as presented by the multidimensional, user-oriented synthetic environment virtual reality shell, which promises significant advances in the emerging discipline of virtual manufacturing.

Once a display or data need to be shared with other virtual work space participants, a voice or other command will allow each person to transfer a display for others to see and use. When the concurrent team has reached consensus, the responsible party will download the final design data for further use, perhaps by an information-driven manufacturing system. Advanced communications features will allow many kinds of data transfer, including virtual participation via prerecorded video and audio messages to the virtual work space session.

A virtual video camera feature allows the entire design, analysis, and simulation session to be recorded for further use. Such archives will include the actual

computer data, the design intent, and conversations (if required). For future DOE projects, the capability of retrieving archived design sessions will be invaluable. In fact, retrospective design sessions could be convened for existing weapons systems, and the opinions and anecdotes of the original designers captured and arranged in hypertext format. By augmenting such sessions with original drawing data and design information and analyses, and by including video sessions of assembly and testing, enough manufacturing information could be gathered in one place so that future weapons designers could access and reuse it without having to start from the beginning. Weapons product documentation could conceivably be a file cabinet of CD-ROMs.



Sofia Pastoriza-Nuñez and Dave Rogers test some of the virtual reality gear developed at Sandia. Virtual reality makes it possible for a person to feel immersed in a constructed environment consisting only of computer displays.

### ***Advanced Rapid Manufacturing***

*(for the Assistant Secretary for Defense Programs [program GB])*

Advanced rapid manufacturing is the logical successor to rapid prototyping. Presently, at least thirty fabrication technologies may be called rapid prototyping. The most mature and interesting of these are classified as solid free-form fabrication, which are additive processes that build solid three-dimensional parts one thin layer at a time. Included in this class are the following: stereolithography, which grows parts from a vat of laser-activated, photo-reactive polymer liquid; selective laser sintering, in which a

laser melts together particles of plastic or wax to make solid parts; and direct shell production, also called three-dimensional printing, which sprays binder selectively onto ceramic powder to make prototype parts. Other rapid prototyping processes use combinations or variations of these techniques, or utilize rapid prototyping processes as intermediate steps (e.g., producing wax molds for investment casting by selective laser sintering).

Since the invention of stereolithography in the mid-1980s, rapid prototyping has revolutionized the production of physical prototypes. It is now practicable to design a model in three dimensions on a CAD system and then have it fabricated in hours or min-

utes at a rapid prototyping facility. Compared to machined or cast prototypes made by conventional means, this procedure can reduce the total procurement time from months or weeks to days or hours. Dimensional scaling of small models to large size and vice-versa is routine for fit checks and detailed design reviews. Additionally, layer-by-layer techniques allow the fabrication of one-piece, seamless assemblies not possible with conventional methods.

An important limitation of rapid prototyping models is existing materials. Most rapidly prototyped models are fragile or structurally sufficient only for display, demonstrations, or fit checks. They lack the strength, wear resistance, and temperature stability of actual engineering materials. Advanced rapid manufacturing refers to the logical next stage in the development of rapid prototyping, namely the rapid fabrication of production-quality parts in a similar time scale. Advanced rapid manufacturing has the potential to revolutionize manufacturing the way rapid prototyping revolutionized prototyping. The Sandia Advanced Rapid Manufacturing Proposal Team has set a goal of making final-quality parts at least one-hundred times faster than possible by current conventional manufacturing. This will involve attention to each element of the product realization process, from initial design through physical fabrication, and the integration of each element by efficient information flow.

Several rapid manufacturing technologies and techniques already exist in prototypical form within Sandia, and it is useful to learn from them. For example, Sandia's FASTCAST™ program utilizes only a few of the elements that advanced rapid manufacturing proposes to use, yet FASTCAST™ has already reduced the time from design to the first manufactured casting by a factor of ten. In addition, FASTCAST™ is the core technology of a new consortium to develop spin-off technology for US industry. One critical element of FASTCAST™ is the ability of rapid prototyping to produce very accurate patterns for castings.

A full complement of rapid-response manufacturing and production will be required to support the nuclear weapon complex vision of a comprehensive dual-benefit industrial base. This capability to meet stringent defense needs by advanced industrial technologies is an exemplar of the dual-benefit concept. Advanced rapid manufacturing promises to expand this concept and to speed it up significantly. Advanced rapid manufacturing aims for an integrated portfolio of manufacturing technologies (from conceptual design through virtual manufacturing to physical fabrication) that will meet DOE Defense Program production needs orders of magnitude faster than possible today, and at the same time enable US manufacturers to stay ahead in the competition for civilian international markets.

## **Smart Material Systems**

*(for the Assistant Secretary for Defense Programs [program GB])*

Improvements in manufacturing technologies can be made using smart material systems technology. Smart materials and structures have the ability to beneficially respond to internal and external stimulation through intelligent sensing, processing, and controls. This technology provides the designer an expanded capability and new design methodology in the materials and structures area that can be employed for a variety of manufacturing tasks, including the design of new products or manufacturing systems.

First, smart material systems enable a designer to use lightweight structural systems for high-precision tasks. Second, smart material systems convey information about the current structural health of the system and use this information to adapt and achieve a desired goal. Third, smart material systems technology facilitates manufacturing process control via embedded sensors. Intelligent material and structural systems often involve flexible structure control problems. These systems have sensory and actuating characteristics that can respond in real time to the environment and modify responses to overcome undesirable and unexpected stimuli. The solution to such problems is directly related to complementary technologies in intelligent process control and intelligent machines.

Cost and time to manufacture can be achieved through application of smart material systems. This capability is made possible because of recent advances in a number of related technologies, including materials, sensing and actuating, processing, reliable structural modeling and simulation, and microdevices. It is now often less expensive to incorporate sensors, actuators, and computing than to use heavy structures to achieve the accuracy and precision required for a reliable design or manufacturing task. It is a requirement of agile manufacturing that processes be able to adapt to new families of design, and this adaptability is inherent in smart material and structural systems.

To maintain accuracy in precision manufacturing, operations will require an ability to sense and actively control the vibration inherent in many procedures. This use of active vibration control is needed for advanced lithography machines for semiconductors or flat panels to achieve the desired precision. Structural systems and equipment used to produce weapon parts in agile manufacturing operations will require intelligence and adaptability. Also required are very accurate modeling and simulation capabilities to enable virtual prototyping of weapons, thus avoiding costly hardware iterations. On-line system identification is required for control of flexible structural systems, for detection of the onset of chatter and suppression of vibration, for precision machine tool

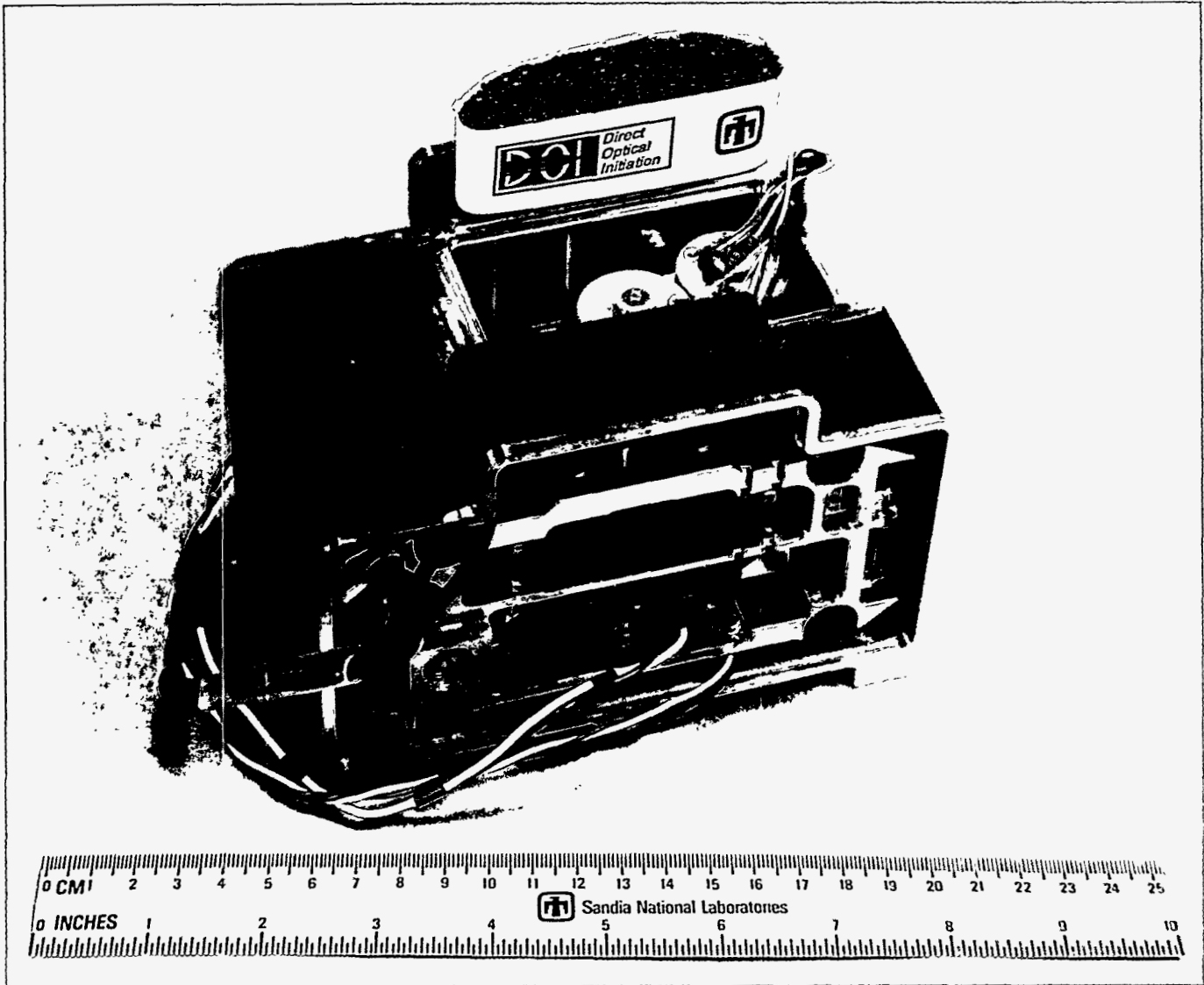

Direct Optical Initiation (DOI) technology was used to develop this optical firing system for future weapon systems. DOI shows dual-benefit promise for many medical applications.

manufacturing systems requiring vibration reduction, and other precision cutting or grinding operations.

Other manufacturing applications of smart materials include the following: embedded sensors to monitor the cure cycle for composite materials; damage detection and health monitoring of sensitive structural systems; shape memory alloys as clamping devices for automated production line handling to eliminate environmentally damaging hydraulic clamping systems; process control of extruded and injected molded plastics; temperature and wear compensation; precision oscillating equipment; and nonintrusive sensing of manufacturing process parameters internal to material processing.

Current efforts in the field of smart material and structural systems by the private sector and other government agencies have increased significantly in recent years. Sandia has a unique opportunity to bring its resources to bear on a technology of great importance to this country. Advances in this field require the resources of an organization that has both breadth and depth in the individual technologies that make up this multidisciplinary field. Such expertise requires the integration of experimental and analytical research and development in materials, structures, processing, sensors, and controls, plus a capability for prototype device development and systems engineering—skills that are well established at Sandia.



---

## **Manufacturing Energy Conservation**

*(for the Assistant Secretary for Energy Efficiency and Renewable Energy [program ED])*

Sandia's work in DOE's Industrial Waste Reduction Program is focused on changing the initial processes used in manufacturing to reduce both the waste generated and the energy used in manufacturing. This approach has great potential to help industry because it improves the entire manufacturing process. Industry supports this program because of its potential to yield huge savings and to help protect the environment.

Sandia supports DOE in areas that can enhance advanced manufacturing, such as industrial waste reduction and environmentally conscious manufacturing. Integrating concepts and lessons learned from these projects into the baseline planning for tomorrow's manufacturing programs will enhance US competitiveness by making products less costly and more desirable in worldwide environmental markets.

The waste reduction program has already proved itself of value to US industry. It is currently industry-driven, market-based, and cost-shared with industry, and it leverages investments already made by the federal government in the national laboratories.

In a parallel effort, Sandia has been coordinating demonstrations of environmentally conscious manufacturing in the DOE weapons complex. Sandia uses an integrated systems approach that attempts to reduce the ecological impacts of industrial activity and improve efficiency of energy use without sacrificing quality, reliability, or performance. Over the next five years, our strategy for the program will be to concentrate on the application of environmentally conscious manufacturing through collaboration and partnership with industry and by making Sandia a national center for the methodology.

Specific support is needed to integrate environmentally conscious manufacturing and energy reduction into the design of advanced manufacturing processes. Known approaches (such as solvent substitution, materials conservation, and process monitoring and control) will be applied where possible. In cases where opportunities for significant energy conservation present themselves, new approaches will be developed.

## **Technology-Based US Product Reliability Leadership**

*(for the Assistant Secretary for Defense Programs [program GB])*

DOE and commercial industry have similar requirements for high-reliability systems and components. Meeting these requirements, a serious challenge for the nuclear weapons complex today, will become a critical

issue as production downsizes and we move toward agile manufacturing.

Quality will be vital in meeting sponsors' expectations for reliable systems. The key issue will be to achieve high reliability competitively (i.e., to produce extremely low failure rates while producing the product at the lowest possible cost).

Two essential components for performance and leadership are a quality culture and the application of reliability technologies. Quality culture refers to the values and principles of individuals and organizations. Reliability technologies refers to the base of technical competencies required for a practical, competitive implementation of a quality culture. This base includes such competencies as reliability physics, failure analysis, nondestructive testing, process control, and design for manufacturing.

The military and economic security of the United States demands that the nation achieve and sustain competency and leadership in technologies for quality and reliability. This initiative proposes a multiorganizational National Center for Ultra-Reliability Engineering (NCURE). Sandia possesses strong qualifications for leadership in a cooperative NCURE program. The extreme consequences of a nuclear weapon failure have required Sandia to develop and maintain a broad base of expertise in quality and reliability technologies. NCURE will use capabilities from the entire DOE complex and will broadly support US industry and government programs. Sandia will transfer and disseminate advanced quality technologies.

In addition, NCURE will sponsor quality research and development in other areas.

## **Quality in Agile Manufacturing**

Strategies will be identified for ensuring high quality and reliability in the small-lot, high-product-mix environment of downsized defense production and agile manufacturing. We will also define key reliability technology drivers of the future and pursue related research and development.

## **Reliability Technology Leadership in Dual-use Technologies**

NCURE will identify key dual-use technologies and work with industry to establish and maintain world-class quality technology capabilities in these areas. For example, NCURE will provide concurrent engineering support for developing advanced electronic technologies such as flat panel displays, high-speed electronics, and high-temperature electronics.

## **Expert Systems**

All organizations are susceptible to the loss of valuable expertise as key technical people retire. This problem has particularly important implications for DOE because it has responsibility for nuclear weapons that have service lives longer than the careers of the original designers. An

---

important goal of NCURE will be to develop practical expert-system methodologies to preserve the knowledge of such individuals.

### **Concurrent Engineering Practices**

*(for the Assistant Secretary for Defense Programs [program GB])*

Sandia has initiated an effort to create in the near term a process both to build small quantities of replacement weapons and to mobilize quickly for volume production upon command. This program will develop processes for weapon product realization in the nuclear weapons complex to support DOE's vision of a smaller, more cost-effective complex to support dismantlement, stockpile management, and new weapon development. It is not intended to support direct research and development of new technologies for weapon products. Instead, it tightly couples the product cycle from design through dismantlement, resulting in efficient, flexible, and affordable design and production.

The nuclear weapons complex functions with traditional industrial engineering processes for product realization. A more modern approach is needed. This initiative will define and implement concurrent engineering processes for the realization of weapons.

Concurrent engineering (in the context of DOE Defense Programs weapons production) is defined as a process for product realization that improves cycle time by using teamwork from concept to disposal, with special emphasis on up-front engineering of all process and life-cycle requirements. Concurrent engineering offers a systematic approach to the integrated, simultaneous design of products and their associated fabrication processes. This approach is intended to cause weapon developers to consider all elements of the product life cycle from concept to disposal, including quality, cost, schedule, and performance.

To implement this initiative, Sandia will conduct activities in two major areas. First, an integrated systems approach will be employed for weapon design and manufacturing that encompasses the entire life cycle of weapon components. Building on the Solar Total Energy Project, Pit Reuse for Enhanced Safety and Security, Focal Point, and other demonstration programs, the initiative will focus on a few pilot product realization projects. These pilot projects will be the vehicles for development cycle activities.

Specific subsystems and components will be selected as pilot projects. The two initial candidates will be a fireset/programmer and the focal point paste explosives system. The entire integrated approach will be exercised on these prototypical applications, including systems management (emphasizing rapid cycle time), design for manufacturability and cost, process characterization (focused on feedback to the design process), continuous

improvement of all processes, waste minimization, and demonstration of industrial partnerships. New pilot projects will be selected as the new process gains momentum.

The second major area to be addressed is the formation of multidisciplinary teams to apply concurrent engineering principles to design, manufacturing, and dismantlement processes. These teams will include designers, manufacturing engineers, materials and process scientists, environmental safety and health engineers, waste management specialists, information management specialists, and so forth. By improving the manufacturability of current nuclear weapon components, engineers can generate ideas that may benefit stockpile and dismantlement activities and achieve better designs for future production.

A project management approach will ensure that this initiative develops according to planned strategic intent, that resources are properly aligned with requirements, and that effective linkages are maintained between customers and support groups.

### **Production Readiness Assurance**

*(for the Assistant Secretary for Defense Programs [program GB])*

Manufacturing is a crucial component of the defense technology base and a principal factor in US economic security. The new weapons procurement strategy calls for ongoing development of advanced weapon systems to retain America's technological edge in military systems. In contrast to past practice, however, these new weapon systems may not be immediately produced in quantity. Instead, the nation will retain the capability to produce them quickly when needed in response to threatening world conditions.

This strategy of virtual forces affects the US military's ability to maintain a substantive fighting capability and a credible deterrent in several ways. First, the concept of readiness will have to be expanded to include the infrastructure that will create weapons systems. This infrastructure includes both captive production facilities and industrial production capacity. These industrial production facilities will require unprecedented flexibility to produce a mix of military and nonmilitary products. The nation will need new methods for monitoring and assuring the readiness of this large production complex to meet its critical, time-limited needs in periods of crisis.

Second, accredited production processes are needed that can operate at low- or no-volume levels for many years and then be turned on for volume production with no loss of quality. The technological implications of this requirement are profound. The manufacturing processes must be validated to high quality standards with only small sample sizes. The corporate memory for those processes must be preserved so that it can be recalled without a lengthy learning curve. In addition, there must

be procedures to revalidate (and periodically modernize) the reinstated processes without lengthy pilot production runs. These needs are beyond the current state of the art in manufacturing.

Third, the defense production infrastructure will need an agility that it does not possess today. If a decision to rearm should be made, it is likely that modifications to extant weapons systems will be specified at the same time. Those modifications will be based on an assessment of the specific threat to be countered. The engineering and design functions needed to accomplish these changes will have to exhibit the same agility as the fabrication systems that produce them. Thus, highly integrated, paperless, concurrent design and analysis systems will have to function seamlessly with the rest of the procurement and production infrastructure. It will be a great

challenge to make the agile manufacturing concept a reality in the defense procurement arena.

These challenges facing defense manufacturing must also be addressed by DOE, and in some cases the problems will be even more difficult. The production volumes of nuclear weapons will almost certainly be quite small, but the standards for quality will remain uniquely high. Moreover, the ability to resume quantity production must be retained. As actual production experience diminishes, it will become more difficult to sustain our ability to produce a high-quality product unless agile manufacturing technologies and practices are available and have been demonstrated. DOE must become a leader in integrated engineering, design, and production in order to meet its responsibilities in the twenty-first century.

**Funding Requirements for Initiative Project Proposals in  
Advanced Manufacturing Technology  
(Dollars in Constant FY 1994 Millions; Personnel in FTEs)**

	<u>Year 1</u>	<u>Year 2</u>	<u>Year 3</u>	<u>Year 4</u>	<u>Year 5</u>
<b>Information-Driven Manufacturing</b>					
Operating	4.0	5.0	8.0	12.0	18.0
Capital Equipment	1.0	2.0	2.0	2.0	1.0
Total Cost	5.0	7.0	10.0	14.0	19.0
Direct Personnel	15	20	30	45	60
<b>Agile, Clean, Energy-Efficient Manufacturing</b>					
Operating	8.0	16.0	24.0	35.0	37.0
Capital Equipment	2.0	4.0	6.0	5.0	3.0
Total Cost	10.0	20.0	30.0	40.0	40.0
Direct Personnel	35	70	100	165	170
<b>Environmentally Conscious Manufacturing</b>					
Operating	10.0	15.0	20.0	25.0	25.0
Capital Equipment	2.0	4.0	5.0	4.0	3.0
Total Cost	12.0	19.0	25.0	29.0	28.0
Direct Personnel	25	30	50	55	55
<b>Advanced Materials and Manufacturing Technology</b>					
Operating	10.0	10.0	15.0	15.0	20.0
Capital Equipment	5.0	10.0	10.0	10.0	5.0
Total Cost	15.0	20.0	25.0	25.0	25.0
Direct Personnel	40	40	60	60	60
<b>Intelligent Manufacturing Science and Engineering</b>					
Operating	6.0	10.0	15.0	15.0	20.0
Capital Equipment	1.0	2.0	2.0	2.0	1.0
Total Cost	7.0	12.0	17.0	17.0	21.0
Direct Personnel	25	40	50	50	50

Funding Requirements for Initiative Project Proposals in  
Advanced Manufacturing Technology (Continued)  
(Dollars in Constant FY 1994 Millions; Personnel in FTEs)

	<u>Year 1</u>	<u>Year 2</u>	<u>Year 3</u>	<u>Year 4</u>	<u>Year 5</u>
Virtual Manufacturing Environments					
Operating	1.2	2.5	1.8	1.8	1.8
Capital Equipment	1.0	1.5	1.0	0.8	0.8
Total Cost	2.2	4.0	2.8	2.6	2.6
Direct Personnel	6	10	12	12	12
Advanced Rapid Manufacturing					
Operating	5.0	8.0	10.0	10.0	10.0
Capital Equipment	2.0	3.0	3.0	2.0	2.0
Total Cost	7.0	11.0	13.0	12.0	12.0
Direct Personnel	20	35	40	40	40
Smart Material Systems					
Operating	2.5	5.0	8.0	13.0	14.0
Capital Equipment	0.5	2.0	2.0	2.0	1.0
Total Cost	3.0	7.0	10.0	15.0	15.0
Direct Personnel	10	20	35	50	50
Manufacturing Energy Conservation					
Operating	6.0	10.0	15.0	15.0	15.0
Direct Personnel	10	18	20	20	20
Technology-Based US Product Reliability Leadership					
Operating	5.0	10.0	12.5	12.5	12.5
Capital Equipment	1.0	2.0	2.0	2.0	1.0
Total Cost	6.0	12.0	14.5	14.5	13.5
Direct Personnel	25	40	50	50	50
Concurrent Engineering Practices					
Operating	8.0	8.0	6.0	6.0	6.0
Direct Personnel	32	32	24	24	24
Production Readiness Assurance					
Operating	12.0	25.0	31.0	31.0	31.0
Capital Equipment	2.0	4.0	7.0	7.0	5.0
Total Cost	14.0	29.0	38.0	38.0	36.0
Direct Personnel	50	100	115	115	115
<b>Total, Advanced Manufacturing Technology</b>					
Operating	77.7	124.5	166.3	191.3	210.3
Capital Equipment	17.5	34.5	40.0	36.8	22.8
Total Cost	95.2	159.0	206.3	228.1	233.1
Direct Personnel	293	455	586	686	706

---

## Electronics Technology

Sandia's electronics capabilities and programs integrate the entire electronic-component realization process at a single site. Our capabilities in this arena are unique among US government facilities. We apply our resources to developing custom components for specialized DOE and other federal agency applications as well as precompetitive technologies for partners in the private sector.

Sandia's broad-based activities provide a focus for DOE's response to industry-generated technology road maps such as those prepared by the Semiconductor Industry Association and the Optoelectronics Industry Development Association. In addition, we provide a direct mechanism for applying university research to manufacturable electronics products and processes.

Sandia's Center for Microelectronics Technologies provides a unique capability for research and development relevant to industry. This capability is being accessed by industry through a five-year, \$100 million cooperative research and development agreement (CRADA) with the US semiconductor industry SEMATECH consortium, as well as through CRADAs with individual companies. The center is supported by a large range of semiconductor and microelectronics capabilities.

Activities of the center in support of the US semiconductor industry include the Semiconductor Equipment Technology Center (SETEC), the Contamination-Free Manufacturing Research Center, and the Equipment Design Support Center, all joint projects with SEMATECH.

The Center for Microelectronics Technologies conducts joint projection extreme ultraviolet lithography programs with industrial partners to develop the next generation of processes and processing equipment. The center is also the site for developing environmentally conscious manufacturing and environmentally safe and healthful procedures for semiconductor manufacturing. Sandia is working with SEMATECH and US equipment manufacturers represented by SEMATECH to develop a semiconductor equipment design center in SETEC.

Sandia's Microelectronics Development Laboratory is a 74,000-square-foot facility that includes 30,000 square feet of clean-room space with 12,500 square feet of class-1 clean space in twenty-two separate clean rooms. The laboratory's design provides maximum flexibility for new processing equipment and device technologies and is uniquely configurable to support the joint Center for Contamination-Free Manufacturing. A large donation of equipment and technology by IBM provides a state-of-the-art submicrometer silicon-integrated-circuit research and development line. The Microelectronics Development Laboratory's equipment supports the total semiconductor development cycle, including research, design, fabrication, test, prototype delivery, qualification,

and technology transfer. These facilities also support intelligent micromachining and intelligent sensor and display research, and directly impact electronics packaging and assembly.

Sandia's Microelectronics Quality and Reliability Center provides staff and equipment to evaluate and verify electrical and mechanical properties of microelectronic materials, design, verification, and construction at the component level. Sandia's reliability physics and engineering efforts draw upon materials science programs that develop basic understanding of failure mechanisms such as electromigration or stress voiding, defects in insulators and metallizations, and defects in semiconductors. Sandia's National Center for Ultra-Reliability Engineering program, which focuses on ultra-reliability in electronics components for nuclear weapons, is transferring these techniques to commercial electronics manufacturers.

The Center for Contamination-Free Manufacturing Research at Sandia was formalized by a CRADA with SEMATECH in 1992. This center exploits the unique layout of Sandia's Microelectronics Development Laboratory to conduct experiments to advance semiconductor manufacturing concepts and use equipment to reduce contamination that limits the yield of integrated-circuit manufacturing processes.

The center conducts and coordinates research in cost-effective, contamination-free manufacturing technologies involving features as small as 0.2 micrometers and removal of defects as small as 0.01 micrometers (the size of bacteria). Research focuses on the effects of chemical particulates and electrostatic, thermal, and electromagnetic (including light) radiation contamination on circuit yield and performance. The center also helps develop the following: equipment and processes; improved equipment reliability through software quality, ergonomics, and modeling; and new lithography devices, material components, and equipment. These activities are an extension of Sandia's historic development of the laminar-flow clean room, which made possible the entire microelectronics industry.

Sandia was a pioneer in the development of compound semiconductors. Our Center for Compound Semiconductor Science and Technology pioneered the strained-layer-superlattice (SLS) material and such SLS-based devices as pseudomorphic, high-electron-mobility transistors and circuits, as well as such semiconductor photonic devices as vertical cavity surface emitting lasers. In this laboratory Sandia engineers demonstrated the advantages of strained-layer superlattices, which today are responsible for the highest-speed, highest-efficiency, and longest-lived semiconductor lasers, transistors, and integrated circuits in the world.

The center supports the full range of theoretical and experimental activities for solid-state physics, materials science, crystal growth, device and circuit design, and

fabrication to develop the next generation of compound semiconductor electronic and optoelectronic devices. Facilities include capabilities for extensive molecular beam epitaxy and metal-organic chemical vapor deposition crystal growth, ion implantation, and electron-beam lithography in a 6,000-square-foot, class-100 clean room with state-of-the-art processing equipment.

Sandia's program for sensor development employs more than one hundred technical professionals who extend the state of the art in sensor technologies for manufacturing and other applications. Unique facilities include the following: the Microelectronics Development Laboratory (described above); the Intelligent Machine/Robot Advanced Sensor and Control Laboratory, consisting of twenty-five different development laboratories containing the latest commercially available robots, five-axis computer-numerically-controlled machines, mobile platforms, state-of-the-art research robots, and advanced controllers; the Microsensors Research and Development Laboratory, including fifteen separate research, engineering, and development laboratories that fabricate, package, and integrate new sensors into fieldable subsystems; and the Sensor Test and Modeling Laboratory, which has numerical modeling and equipment characterization facilities for environmental, chemical, electromagnetic, stress, and thermal testing.

The Advanced Manufacturing Processes Laboratory is a facility for advanced prototype manufacturing housed in a 100,000-square-foot building featuring equipment for hybrid microcircuits, thin films, printed circuits, ceramics, plastics, and rapid prototyping. The laboratory coordinates its activities with the Integrated Manufacturing Technologies Laboratory at Sandia's California facility.

This design center is chartered to focus on reliability and quality of manufacturing processes through understanding and qualification of manufacturing processes. Particular emphasis is given to automation and robotic handling through complementary programs in both software and robotic hardware.

This facility is also a proving ground for custom sensors for manufacturing processes. Emphasis is placed on developing new approaches to joining and sealing dissimilar materials that have particular relevance to advanced packaging. Collaborations with the Iaccoca Institute at Lehigh University have led the Advanced Manufacturing Processes Laboratory to support empirical investigations of higher-level manufacturing issues such as control, optimization of material flow, and workspace organization.

To provide custom designs for its customers, Sandia has developed an integrated approach to the design of microelectronic components and systems. As part of these activities, Sandia writes custom support software for commercial vendors, which has become the basis for multiple commercial design packages. Sandia's integrated software environment combines circuit-level simulators,

logic-level simulations, and both analog and digital system-level simulators—with complete verification from chip to multichip module to the printed circuit board.

Sandia's capabilities and facilities in electronics are comprehensive and span the development cycle from research to manufacturing support. This competency is certainly unique among US government facilities and is competitive with the best electronics research and development facilities in the world. The following package of initiative project proposals is designed to exploit these capabilities for maximum benefit to both defense and civilian needs.

## Project Initiatives

### *Electronics Technology Center*

*(for the Assistant Secretary for Defense Programs [program GB])*

Electronic components are at the heart of every weapon system and of many commercial products. Electronic products range in complexity and sophistication from the portable radio to very sophisticated computers, smart bombs, and life-support systems. Electronics has revolutionized the ways in which the nation defends itself and has affected nearly every aspect of our lives. Our automobiles now go 30,000 miles without needing a tune-up because of electronic fuel delivery systems and our homes include electronically controlled appliances, entertainment devices, security systems, and in some cases life support systems.

Sandia is DOE's electronics design and test facility. For more than forty years Sandia has designed manufacturable electronic systems that meet the stringent surety requirements of nuclear weapons. Sandia's successful fulfillment of this mission has created a world-class capability to design, model, test, and prototype electronic subsystems. Yet, outstanding as this capability is, it needs to become even better in order to meet DOE's changing needs and to enable American industry to compete globally.

The Electronics Technology Center needs to be established at Sandia to meet the dual needs of fulfilling DOE's requirements while providing technologies that permit American industry to compete globally. The center would meet these needs by dramatically improving electronic product realization processes and technologies. The success of the center would be measured by its technological capabilities to simultaneously shorten the concept-to-product development cycle, reduce development and manufacturing costs, and minimize the product's environmental impact through the production, use, and disposal of life cycle elements.

The near-term focus of the center's work would be on improved design and performance modeling tools. At

present, the best design and modeling tools for electronic products require an experienced, well-trained designer and often a significant capital investment in hardware and software. Even under the best conditions, very few common ties exist in data input formats among the various tools. Consequently, the product designer must enter design data into the initial computer-aided design file in one format, then reenter the design data in a second format for circuit electrical performance modeling, then a third time for thermal and mechanical analysis, and a fourth time for circuit board physical layout for fabrication, and so on.

One initial thrust of the Electronics Technology Center would develop overlay expert systems that obviate this costly duplication of effort. These multiple entries are costly both in the time and talent consumed and also in the errors introduced and propagated at each data entry point. These errors often lead to multiple prototyping and slow the entry of the product to the market, which could lead to lost market share.

Recently, Sandia designers were able to demonstrate a dramatic decrease in development cost and cycle time. They successfully brought a complicated, high-value defense product from concept to product without ever building a physical prototype. The prototype existed only as bit patterns in a computer memory. The use of such virtual prototyping resulted in a well characterized design and robust product. The development period was characterized by rapid design iteration cycles and tremendous savings in cost and development time. This work exemplifies the promise and payoff of this proposed center.

The development and use of advanced product realization technologies in the Electronics Technology Center would ensure the Laboratories' capability to meet DOE's changing needs. This initiative would enable the delivery of manufacturable designs in much less time, at a reduced development cost, and with higher product surety than at any time in the past.

Another thrust of the electronics technology initiative would be the development of a design assistant to lead engineers through the concept-to-product cycle. This computer-based design assistant would facilitate the skilled engineer's use of various tools while simultaneously augmenting the less skilled engineer's ability to select and use the best and most appropriate design tools and processes. This capability is viewed by many in the electronics products industries as a key enabler of global marketing success for American industry. At the conclusion of this phase of the initiative, the technologies of the Electronics Technology Center would be a truly dual-benefit capability to meet DOE needs while providing a strategic advantage for the nation's electronics industry.

A subsequent phase of this initiative would operate an electronics technology center for the dual purposes of national security and national economic competitiveness. Response to DOE and ease of access by American industry

would be the criteria to determine this center's viability.

This initiative would require partnerships via advanced manufacturing initiatives in both industrial consortia and other federal agencies. The National Institute of Standards and Technology National Information Infrastructure initiative and the National Center for Manufacturing Sciences' Environmentally Conscious Manufacturing programs are examples of potential synergistic relationships.

### ***Center for Microelectronics Technologies*** *(for the Assistant Secretary for Defense Programs [program GB])*

Microelectronics is a critical technology that pervades both government and commercial systems. Microelectronics underlies all high-technology areas: from manufacturing to computing; from transportation to banking; from education to communications. The electronics industry, the largest manufacturing sector in the United States (with three times as many jobs as the entire domestic automobile industry), is losing market share to government-subsidized foreign competition. Foreign competition in microelectronics and photonics also threatens the security of the United States by reducing the number of domestic manufacturers of advanced components critical to modern defense systems. Under these pressures, the US semiconductor industry has drawn together in unprecedented fashion. Recently, the US Semiconductor Industry Association (SIA) released a technology plan for the US microelectronics industry through the year 2013 that was assembled by 179 top US semiconductor experts from industry, government, and universities. The road map identifies opportunities for government laboratories to help industry address generic technology needs.

In response to the SIA's directly stated needs, Sandia established the Center for Microelectronics Technologies (CMT) to assist the industry with dual-benefit projects. This center was created by combining the existing Microelectronics Development Laboratory (MDL) with a major donation from the private sector of equipment and technology valued at over \$63 million. The 74,000-square-foot MDL at Sandia includes 30,000 square feet of clean-room space with 12,500 square feet of class-1 clean space in twenty-two separate clean rooms. The IBM equipment and technology donation provides a state-of-the-art submicrometer silicon-integrated-circuit research and development line supporting the total semiconductor development cycle. The CMT will create a centralized site in partnership with the US microelectronics industry and US universities to develop the technologies, the manufacturing equipment, and the advanced processes upon which the future of both commercial and defense electronics depends. The CMT will also train US graduate students in the most advanced integrated circuit technol-

ogies in the world. A combined advisory board will select projects that combine teams of researchers selected from US universities, businesses, and national laboratories with major industry partners who agree to commercialize the results. The CMT's major impacts are on processing methods and equipment (singled out as critical elements of this technology in the DOE Defense Programs Critical Technology Plan) and on US semiconductor manufacturing equipment, another key goal.

The federal government is the major beneficiary of this work through custom products for government applications and through support for the domestic manufacturing base that provides these products. Industry will benefit through specific projects that will be cost-shared by government and the private sector. Initial government support should be \$50 million per year and should grow to \$100 million per year in five years, an increasing percentage of which will be supported by industry organizations such as SEMATECH through joint programs.

### ***National Optoelectronics Initiative***

*(for the Assistant Secretary for Defense Programs [program GB])*

Optoelectronics will provide the hardware for the information highways that will carry the United States into the twenty-first century. Optoelectronic elements will provide the high-data-rate communication links between remote manufacturing sites to create the agile enterprises in the DOE nuclear weapons complex for cost-effective realization of future weapon systems. Over shorter distances, optoelectronics will become the means by which computers communicate with storage and output devices and even among multichip modules that will provide the intelligence within computer workstations in the future.

In the private sector, optoelectronics information networks will pervade the lives of citizens by providing access to vast quantities of data for commerce, information, education, and entertainment. Information highways based on optical components may soon become as critical to our commercial and defense infrastructure as bridges and highways.

Despite having pioneered the components responsible for this revolution, the US optoelectronics industry's market share is eroding. Japan has increased optoelectronics production from \$700 million in 1980 to \$32 billion in 1990. During this decade, US producers saw their world market share decline from 50 percent to less than 15 percent. If foreign producers establish a dominant position in optoelectronics, it is unlikely that US producers will ever recapture sufficient market share to sustain domestic production of these critical enabling components.

Similar to the US Semiconductor Industry Association

for integrated-circuit technology, the US Optoelectronics Industry Development Association (OIDA) is creating a technology road map to chart a course for common action. OIDA selected five critical areas: displays, optical communications, optical data storage, optical interconnection and switching, and hard copy output. Because displays are responsible for half the sales volume of electronic products, a separate project proposal has been formulated (see below).

Advances in the four other critical areas depend on two key competencies: optoelectronic materials and optoelectronic manufacturing (especially processes and production equipment). These are areas of particular strength at Sandia. We propose applying the resources of the Compound Semiconductor Science and Technology Center to support a national optoelectronics initiative in a dual-use partnership with the US optoelectronics industry.

Optoelectronics manufacturing relies on expensive facilities with specialized production equipment. Sandia's Compound Semiconductor Science and Technology Center provides the ideal facility at which cost-leveraged partnerships of US industry, universities, and government researchers will perform the precompetitive development of the design tools, processes, and related production equipment essential for US optoelectronics manufacturers.

An advisory board will recommend projects that combine teams of researchers from multiple organizations. These teams will include major industry partners who will commercialize the results. This initiative will have major impacts on processing methods and equipment and on manufacturing equipment, which are as critical for production of optoelectronics as they are for silicon integrated-circuits.

### ***Emissive Flat-Panel Display Technology Center***

*(for the Assistant Secretary for Defense Programs [program GB])*

Displays form the critical interface between humans and the intelligent microelectronic chips that operate today's smart systems. These displays will pervade defense applications from command and control through design and simulation of components and manufacturing processes on high-performance computer work stations. The displays will also have pervasive commercial applications, ranging from medical imaging to information systems and home entertainment. Displays are increasingly overlapping technologies needed for multichip module integration, semiconductor component manufacturing, and underlying electronic materials and process development. Advanced flat-panel displays are predicted by the Japanese Optoelectronics Industry Trade Development Agency (OITDA) and the US Optoelectronics Industry Development Association (OIDA) to represent a \$20-billion-per-year component market by the year 2000.



Although the United States pioneered the technologies responsible for all modern displays, Japanese firms have captured 95 percent of the global display market through their concentration of resources on a single technology: active-matrix, liquid-crystal displays (AMLCDs). However, AMLCD technology is deficient in the areas of power consumption, color, brightness, and ability to operate at video rates. AMLCD technology also suffers from poor manufacturing yields due to unavoidable process complexity because each picture unit (pixel) must be operated by a transistor. An opening exists for competing technologies to overcome the market lead of AMLCD technology. However, to impact global markets, these technologies must not only demonstrate performance advantages but also cost and manufacturing advantages. A critical weakness of these display alternatives is the lack of an infrastructure of manufacturing equipment and processes to permit the transition to volume production. Such infrastructure is beyond the means of any one institution or corporation and requires a common, neutral site for cost-leveraged development of precompetitive technologies.

The US display industry is attempting to leapfrog AMLCDs by developing a competing emissive flat panel display technology. Sandia is supporting this effort through programs in phosphor synthesis and characterization by evaluating various emitter technologies and by developing glass sealing and packaging. Facilities for phosphor and emitter characterization are in place and being used by Sandia's industrial partners. Other projects include low-cost metallization on large-area substrates, sensors for measuring thickness of dielectrics, modeling of glass substrate properties during thermal cycling, and modeling of plasma cells in a plasma color display. These projects will improve the cost, reliability, and understanding of emissive displays, reducing the risk of manufacturing in a globally competitive environment.

Sandia proposes applying selected elements of its Microelectronics Development Laboratory (MDL) and Process Design Laboratory (PDL) to support the development of technologies and manufacturing infrastructure for emissive flat-panel displays. The 74,000-square-foot MDL at Sandia includes 30,000 square feet of clean-room space with 12,500 square feet of class-1 clean space in twenty-two separate clean rooms. The PDL is a 100,000-square-foot, rapid-prototyping facility to support the development of the manufacturing infrastructure for display technologies. Particular programmatic emphasis is given to automation and robotic handling through complementary programs in both software and robotic hardware. This facility also can act as a proving ground for custom sensors for manufacturing processes. Emphasis will be placed on novel approaches to joining and sealing technologies for dissimilar materials required for advanced display concepts. Collaborations with the Iaccoca Institute at Lehigh University on American competitiveness allow Sandia to support empirical

investigations of higher-level manufacturing issues such as control and optimization of material flow and workspace organization.

Display manufacturing relies on expensive facilities with specialized production equipment. Sandia provides the ideal location for cost-leveraged partnerships to generate the precompetitive infrastructure of design tools, processes, and related production equipment essential for US display manufacturers. A combined governing board will select projects that combine teams of researchers selected from US universities, businesses, and national laboratories with major industry partners who agree to commercialize the results. This display initiative will have major impacts on processing methods and equipment and on manufacturing equipment—which are as critical for displays as for silicon integrated-circuit production.

The federal government is the major beneficiary of this work both through custom products for government applications and through support for the domestic manufacturing base that provides these products. Industry will benefit through specific projects, which will be cost-shared between government and the private sector.

### **Electronics Packaging**

*(for the Assistant Secretary for Defense Programs [program GB])*

Electronics packaging is a key technology for the US electronics industry. As packaging requirements have become more stringent and the number of interconnections within a system has multiplied, the success of complex electronic assemblies is increasingly dependent on the development and implementation of robust packaging technologies. Because high-reliability electronic assemblies underlie our medical, communication, and transportation infrastructures, packaging failures can directly impact individual health and safety, as well as the national commerce infrastructure. The strength of advanced electronic packaging can provide US industry with a competitive advantage over international competitors (as demonstrated by IBM's mainframe computer packaging during the 1980s).

Sandia is unique among the national laboratories in having design and production oversight responsibility for all electronic components in DOE systems, with the corresponding responsibility for development, maintenance, and evaluation of packaging technologies. To meet its mission requirements, Sandia has developed a broad-based competency in electronics packaging with the associated infrastructure in facilities and personnel. Sandia's capabilities cover the full spectrum of packaging-related technologies, from fundamental research to prototyping and evaluation. To meet customer requirements, we draw upon a wide range of scientific and engineering disciplines within Sandia.

---

Our competency in electronics packaging includes the following areas:

- package prototyping, including single-chip packaging, printed circuit boards, hybrid microcircuits, multichip modules, high-frequency packaging, and photonic packaging;
- multichip modules, including deposited thin film, ceramic, and laminate technologies;
- computer modeling, including thermal, mechanical, and electromagnetic analysis;
- materials analysis and synthesis;
- design tools, including design for test, auto-layout, and design rule checking;
- assembly research and development;
- failure analysis and reliability;
- qualification;
- test chips and smart substrates;
- three-dimensional packaging;
- optoelectronics packaging and interconnects;
- mixed-mode packaging; and
- flat-panel display packaging.

Sandia conducts packaging-related research and development for DOE and other federal agencies. Many projects are ongoing under the work-for-others arrangements: packaging test methodologies and materials research for the DoD Reliability Without Hermeticity Program, advanced packaging development for a miniaturized DoD synthetic aperture radar and multiprocessor computer; high reliability packaging for NASA deep space probes; use of Sandia's assembly test chip by several federal agencies for package qualification and package assembly monitoring; and secure multichip module design and manufacture for several federal customers. Sandia also is active in the Advanced Assembly and Packaging Technology Interagency Working Group, and was a member of the interagency team that investigated a recent trade complaint regarding ceramic packaging.

US industry values Sandia's unique integrated capability in electronic packaging. Sandia is working on electronics-packaging-related cooperative research with the auto industry for under-the-hood electronics, with the National Center for Manufacturing Sciences for advanced printed circuit board interconnect technology,

and with approximately fifty semiconductor and electronics companies on projects ranging from supplying test chips for electronic packaging qualification to large-scale cooperative research and development with industrial consortia (e.g., the semiconductor industry SEMATECH consortium). Sandians serve on technical advisory boards for the packaging programs at SEMATECH and the Microelectronics and Computer Corporation and have participated in the development of packaging road maps for the Semiconductor Industry Association. US industry recognized the value of our electronics packaging program through a 1993 Research and Development 100 award for our assembly test chip technology.

We think that partnerships with universities are critical to the success of our packaging program. Sandians have been active on university technical advisory boards for electronics packaging programs and have served as mentors and postdoctoral sponsors for students specializing in electronics packaging. Sandia sponsors packaging-related research at several academic institutions and is engaged in cooperative packaging-related research with approximately ten universities.

The broad-based competency in electronics packaging and the associated infrastructure in facilities and technologists developed at Sandia since 1949 has served the nation well by contributing to the mission of DOE and supporting the missions of other federal agencies. More recently, the breadth and depth of our competency in packaging has allowed us to contribute to the nation's economic well-being through partnerships with industry. We are actively expanding the number and scope of industrial partnerships because such partnerships help us maintain our competency in packaging for our DOE and other federal customers while benefiting the nation's economic competitiveness. To make our packaging resources more accessible to industry and academe, we will seek designation of our packaging infrastructure as a national user facility.

### ***Communications Hardware Development Center***

*(for the Assistant Secretary for Defense Programs [program GB])*

High-data-rate, high-bandwidth communication devices will pervade future electronics, from compact computer subassemblies to large terrestrial- and space-based communications systems. The Electronics Industrial Association road map predicts that future integrated circuits and high-density multichip-module packaging will contain thousands of interconnects resulting in data rates of tens to hundreds of gigabits per second. Current interconnect schemes cannot accommodate the packing densities, size reduction, signal timing,

---

and low crosstalk required by high-density, high-data-rate signals. To resolve these issues, multichip-module-to-multichip-module and board-to-board interconnects will employ ribbon-fiber optics and free-space photonic interconnects. Terrestrial and space-based communications as well as local and long-distance networks between workstations will employ similar high-bandwidth technology.

Future defense and commercial communication systems will obtain their performance from compound-semiconductor devices and circuits, including the following: photonic devices; optoelectronic integrated circuits; high-speed digital integrated circuits; microwave and millimeter-wave devices and circuits; and photonic interconnects. Due to the combined requirements of high speed, high frequency, and high density, future communication systems will require low-power devices and circuits with device feature sizes below 0.25 micrometers.

Sandia proposes to employ prototype communications hardware as platforms for insertion of far-reaching, high-impact, compound-semiconductor technology into future defense and commercial systems. Sandia will exploit the capabilities of its Center for Compound-Semiconductor Science and Technology (CCST) to partner with US industry in developing the design, processing, and manufacturing infrastructure essential for developing and manufacturing these critical communications components. Sandia will serve as the neutral site for technology test beds for fiber-optic and free-space interconnects, for workstation networks for both local areas and long distance, and for microwave and millimeter-wave terrestrial and space-based communications.

Sandia's CCST pioneered the strained-layer-superlattice (SLS) material and such SLS-based devices as pseudomorphic high-electron mobility transistors (PHEMTs) and circuits, and such semiconductor photonic devices as vertical cavity surface emitting lasers (VCSELs). Ongoing Sandia efforts on compound-semiconductor complementary digital circuits will create novel components and systems for applications requiring low-power high-speed computing and communication, including the chip sets for driving 10-gigabyte-per-second optical networks. Sandia pioneered the complementary strained-layer logic that will enable very-high-speed, low-power complementary digital circuits in compound semiconductors. Sandia recently invented a red VCSEL ideal for plastic-fiber-based networks of interest both for military applications (ruggedness) and commercial applications (low cost). Sandia pioneered other important vertical cavity devices such as reflection amplitude modulators for both 1.06-micrometer and 1.32-micrometer optical wavelengths. As in the case of the high-speed PHEMTs and the vertical cavity lasers, Sandia inventions are the critical enablers for these proposed communication technologies. This communications hardware initiative also will leverage Sandia's pioneering work in switched multimegabit data service/asynchronous transfer mode

(ATM) links. ATM has been endorsed by the international standards community and has been chosen by Sandia as the enabling technology for establishing national computing and communications leadership within DOE.

Combining high-impact compound semiconductor technology and advanced hardware technology, Sandia will address next-generation computer architectures and communications hardware issues. Results will benefit the national information infrastructure by addressing high-capacity computer networks as well as satellite communications (using Sandia's 60 gigahertz satellite cross-link) for advanced transportation initiatives and wireless communications.

By directly supporting technologies that will lead to smaller, higher-speed computers, this initiative will address several critical DOE defense technologies. It will enhance signal processing and data fusion for synthetic aperture radars engaged in real-time imaging for DOE defense applications. This hardware will allow nuclear weapons and containers to communicate over wireless links for real-time monitoring of the stockpile. Size reduction will enhance embedded computer systems for flight demonstrations of smart bombs. This initiative also supports the DOE technology base by focusing and employing microelectronics, photonics, and engineered materials technologies.

### **Sensors**

*(for the Assistant Secretary for Defense Programs [program GB])*

Advanced sensors are the means by which intelligent (computer-controlled) processors monitor and control the operation of systems and manufacturing processes. Sandia has developed families of novel sensors that sense a range of chemical, thermal, electrical, physical, and mechanical properties for defense and commercial applications, including monitoring environmentally hazardous chemicals and controlling production processes.

Such sensors, fabricated with Sandia's unique microelectronics and materials technologies, have broad new applications in remote monitoring, industrial process improvement, and real-time control. Commercial applications include assessing the quality of vehicle engine oil, identifying the presence of environmental pollutants, monitoring the electrical charge in lead-acid batteries, tracking physical features in manufacturing processes, and indicating the presence and concentrations of explosive gases.

Other applications of Sandia's sensor technology directly impact the nuclear weapons stockpile, weapons surety, advanced weapons designs, and process sensing/control for the nuclear weapons complex. One envisioned application is advanced, chemically selective sensor arrays integrated with radiation sensors to detect very low levels of corrosion by-products to monitor the

integrity of the stockpile and indicate potential problems. Chemical sensors are now used to monitor weapon production processes by providing real-time control of possible chemical emissions into effluent streams at DOE manufacturing facilities. This is an application for which laboratory-sized analytical instruments are not cost-effective or suitable due to power, space, and time limitations.

The suite of Sandia sensor technologies is being continuously refined and augmented with related Sandia microelectronic, material science, signal processing, packaging, and subsystem technologies to expand the range of application. We propose to integrate these sensor activities into a unified program for maximum synergy with a multitude of government, university, and industrial customers. By forming partnerships with industry to develop sensor manufacturing methodologies and leverage development costs, Sandia will serve as the nucleus around which the US sensor industry can generate new technologies and produce the next generation of sensor components. These advances will be needed to make the production and operation of future commercial and defense systems more efficient and competitive.

These sensor technologies have significant dual-use interest for manufacturing-oriented applications, particularly for the semiconductor, automotive, machine tool, textile, and petroleum industries. Sandia's novel transducer developments, based on ultrasonic, fiber-optic, and solid-state technologies, have solved characterization, monitoring, and control problems for improved manufacturing yield, functionality, quality, and environmental compliance.

### ***Intelligent Micromachines***

*(for the Assistant Secretary for Defense Programs [program GB])*

Micromechanics is an emerging field that uses microelectronic fabrication techniques to build ultraminiature mechanical structures with micrometer-dimensioned feature sizes. The small size, low power requirements, and ruggedness of micromachined elements are highly attractive in modern systems and applications. Consequently, micromachining is truly a dual-use enabler. Enormous markets for micromachined

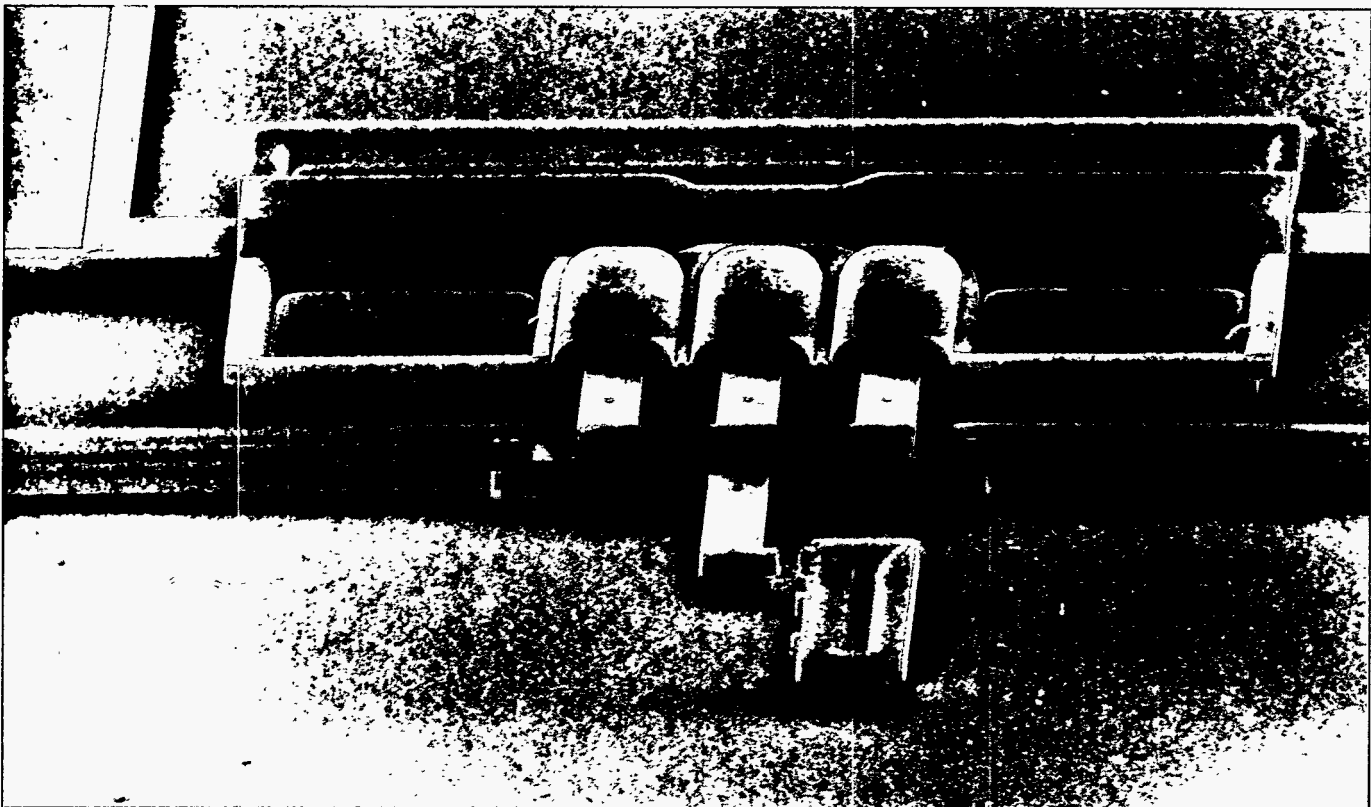

Micromachining technology development at Sandia's Microelectronics Development Laboratory has produced this "micro steam engine" with several possible dual-use applications. Several of these engines could fit on the head of a pin.

components are likely in the automotive, biomedical, aerospace, and robotics industries, as well as in environmental monitoring and restoration. The same families of micromachined structures are important for such Defense Programs applications as ultra-rugged, ultraminiature clock structures for use in weapon systems and a micro-mechanically fabricated version of a stronglink switch.

Micromachining technology is still in its infancy. A major advance in the evolution of micromachined components will occur when micromachines are integrated with low-power, complementary metal-oxide semiconductor (CMOS) integrated circuits on a single chip. The benefits of integrating CMOS integrated circuits with mechanical microstructures are the greater accuracy, performance, and functionality derived from improved signal processing and reduced noise and parasitics.

Although it is widely recognized that most applications would greatly benefit from the ability to integrate control electronics on the same chip as the micromachines, few

micromechanical efforts in the United States have the infrastructure, capacity, or capability to develop this integrated technology and make it available to industry. Sandia proposes to collaborate with US industry to revolutionize the manufacturability, functionality, and applicability of micromachined devices through on-chip integration of micromachines with control electronics. This activity will exploit our unique Microelectronics Development Laboratory for submicrometer-dimension integrated-circuit technology.

The proposed intelligent micromachining will allow US industry, DOE, other federal agencies, and universities to pursue specific projects that require an integrated micromechanics technology. This project will be operated by a government/industry/university partnership for cooperative development and highly leveraged fabrication. This activity would lead to low-cost, manufacturable intelligent micromachine technology and demonstration platforms that can be applied to both the defense and commercial sectors.

**Funding Requirements for Initiative Project Proposals in  
Electronics Technology  
(Dollars in Constant FY 1994 Millions; Personnel in FTEs)**

	<u>Year 1</u>	<u>Year 2</u>	<u>Year 3</u>	<u>Year 4</u>	<u>Year 5</u>
<b>Electronics Technology Center</b>					
Operating	4.5	8.0	8.0	8.0	6.5
Capital Equipment	1.0	3.0	2.0	2.0	1.0
Total Cost	5.5	11.0	10.0	10.0	7.5
Direct Personnel	20	35	35	35	30
<b>Center for Microelectronics Technologies</b>					
Operating	45.0	60.0	75.0	90.0	100.0
Capital Equipment	12.0	15.0	18.0	18.0	20.0
Total Cost	57.0	75.0	93.0	108.0	120.0
Direct Personnel	90	120	150	180	200
<b>National Optoelectronics Initiative</b>					
Operating	25.0	33.0	45.0	60.0	70.0
Capital Equipment	10.0	13.0	16.0	18.0	20.0
Total Cost	35.0	46.0	61.0	78.0	90.0
Direct Personnel	50	66	90	120	140

Funding Requirements for Initiative Project Proposals in  
Electronics Technology (Continued)  
(Dollars in Constant FY 1994 Millions; Personnel in FTEs)

	<u>Year 1</u>	<u>Year 2</u>	<u>Year 3</u>	<u>Year 4</u>	<u>Year 5</u>
<b>Emissive Flat-Panel Display Technology Center</b>					
Operating	25.0	33.0	45.0	60.0	70.0
Capital Equipment	10.0	13.0	16.0	18.0	20.0
Total Cost	35.0	46.0	61.0	78.0	90.0
Direct Personnel	50	66	90	120	140
<b>Electronics Packaging</b>					
Operating	13.5	18.0	24.0	30.0	35.0
Capital Equipment	4.5	4.5	6.0	6.0	6.0
Total Cost	18.0	22.5	30.0	36.0	41.0
Direct Personnel	27	36	48	60	70
<b>Communications Hardware Development Center</b>					
Operating	7.0	8.5	10.0	12.0	14.0
Capital Equipment	3.0	4.0	5.0	5.0	3.0
Total Cost	10.0	12.5	15.0	17.0	17.0
Direct Personnel	13	15	18	18	18
<b>Sensors</b>					
Operating	12.3	14.1	15.5	16.8	18.1
Capital Equipment	1.2	1.7	2.3	2.6	3.1
Total Cost	13.5	15.8	17.8	19.4	21.2
Direct Personnel	52	60	65	70	76
<b>"Smart" Micromachines</b>					
Operating	13.5	18.0	24.0	30.0	35.0
Capital Equipment	4.5	4.5	6.0	6.0	6.0
Total Cost	18.0	22.5	30.0	36.0	41.0
Direct Personnel	27	36	48	60	70
<b>Total, Electronics</b>					
Operating	145.8	192.6	246.5	306.8	348.6
Capital Equipment	46.2	58.7	71.3	75.6	79.1
Total Cost	192.0	251.3	317.8	382.4	427.7
Direct Personnel	329	434	544	663	744

---

## Advanced Information Technology

High-performance computing, computational simulation, and networking have an increasing role in enhancing the security and economic prosperity of the United States. In the future, it will be cheaper, faster, and more accurate to use computational simulation when designing, optimizing, or simulating a system or process than to perform costly trial-and-error experimentation.

Computational simulation has historically been important to Sandia's national security and energy missions and is also key to the future of Sandia and DOE. The advent of massively parallel and distributed hardware, software, and communications capabilities in high-performance computing (in which Sandia played a contributing role) is increasing the importance of simulation and modeling.

Major applications in nuclear weapon design and safety are being joined by new strategic applications in materials and chemistry, including chemical vapor deposition and chemical reactors, semiconductor processing and device simulations, band-gap engineering of new electronic and optoelectronic materials, simulation of enzymes and synthetic catalysts, and design of polymeric materials. For the oil and gas industry, new massively parallel simulations allow huge leaps in our ability to process and interpret seismic exploration data and in our ability to simulate reservoir production and management. The metallurgy industry is benefiting from rapid prototyping of new case parts, made possible by the integration of detailed computational simulation of the casting process into the design of investment castings. Enhanced national security applications in radar imaging and signal processing are growing out of hundredfold increases in simulation capability. Design of synthetic enzymes is leading to new schemes for removal of hazardous pesticides from the environment. Porous flow modeling allows accurate mapping of groundwater transport of hazardous wastes.

More than five hundred Sandia engineers and scientists are involved in the development and application of computational technologies. One of our distinguishing strengths in this area is the ability to develop and integrate theoretical models, advanced numerical methods, and computing technology to create robust, state-of-the-art tools for simulating complex systems and processes.

The Massively Parallel Computing Research Laboratory at Sandia is a national resource for research in high-performance computing and its application to problems in science and engineering. An interdisciplinary team of more than sixty research staff members carries out projects in computational and computer science and in discrete and numerical mathematics. These staff members have access to unique massively parallel computers, including the new Intel PARAGON (with

nearly two thousand processors, 40 gigabytes of memory, and a peak speed of 140 gigaflops), a 1,000-processor nCUBE 2, and a 16,000-processor Connection Machine.

The Massively Parallel Computing Research Laboratory has led the development of algorithms since its award-winning introduction of massively parallel techniques for real engineering applications in 1987. Since 1987, five awards have been received recognizing Sandia's seminal contributions to massively parallel computer technology. Major thrusts of the laboratory include the DOE Grand Challenge in Computer Design of Catalysts and Biocatalysts and development of a broad spectrum of massively parallel applications, including turbulent fluids, chemical vapor deposition, Knudsen flows, porous media, quantum Monte Carlo calculations for molecules and multiparticle systems, massively parallel electromagnetics, and signal processing.

In developing these strategic applications, researchers at the laboratory have invented massively parallel linear algebra methods, new algorithms for molecular mechanics and dynamics, highly scalable methods for quantum chemistry, automatic finite-element adaptive mesh-generation techniques, powerful domain-decomposition and load-balancing techniques, and data visualization methods. Advances in systems technology include portable, lightweight parallel and distributed operating systems, virtual reality environments, new multithreaded architectures, object-oriented C++ constructs for massively parallel applications, and new routing algorithms. Numerical research at the Massively Parallel Computing Research Laboratory is complemented by research in discrete mathematics that includes algorithms for difficult combinatorial optimization problems. This work also involves new communications algorithms for parallel and distributed computing.

In response to a request from the DOE Office of Scientific Computing, we have broadened the scope of our discrete mathematics research to include computational biology. The goal of this effort is to develop robust computational techniques that can be used to validate biological data. We are currently using data obtained on short segments of DNA to reconstruct the order in which these segments occurred in the DNA sequence, and we are developing techniques for jointly constructing evolutionary trees and multiple sequence alignment to better predict protein folding and function.

The Center for Computational Engineering at Sandia/California has an interdisciplinary team of physicists, chemists, biologists, mathematicians, computer scientists, and engineers who interact with a broad external community. The center focuses on applications and works directly with customers to help find the most cost-effective solutions to their problems.

One major thrust of the Center for Computational Engineering is chemical and biochemical modeling. Work in this area ranges from quantum chemistry representation of small molecules (less than fifty atoms) through



David Womble, Art Hale, and David Greenberg examine data from Sandia's Intel XP/S 140 massively parallel supercomputer, which shattered the world computing speed record with a peak speed of 143.3 gigaflops.

molecular dynamic simulations of intermediate-size molecules (hundreds of atoms) to macroscopic diffusion processes involving molar quantities of atoms. Significant recent results include understanding the binding of cyclophosphamide (a cancer drug) to cell DNA and using advanced genetic algorithms to determine the molecular structures of biologically interesting proteins. One realizable product of this computational chemistry expertise is rational drug design, by which biologically active chemicals can be designed from first principles to reduce the high cost of developing pharmaceuticals.

Other work at the Center for Computational Engineering includes modeling to assist in the development of plasma flat-panel displays and to understand the movement of contaminated groundwater through geological media. In addition, manufacturing operations and health care delivery systems are simulated. Each of these activities is in conjunction with a different external customer.

A major driving force in the rise of the information age is the development of low-cost, high-performance workstations. The availability of these workstations is stimulating the growth of multimedia technology (merging voice, video, and data) that will form the basis for a wide spectrum of applications linking people electronically. Sandia has been concentrating on object-oriented design to develop a fully integrated system that ties together the factors required to solve a problem: computational analysis, communication (multimedia and mail), storage, and access.

We have established a heterogeneous environment and test bed consisting of linked workstations from each of the five major workstation vendors. The test bed will develop techniques for implementing clustered heterogeneous computing and the network optimizations required to increase the applicability of this technology. We have also developed metacomputing tools such as the



---

parallel object-oriented environment and tool kit and the distributed audio-video environment as intelligent system interfaces to enhance the productivity of users. In both cases, our efforts have focused on applications to assure that requirements are met for collaborative engineering in support of advanced manufacturing.

Computer networking and wide-area communications have grown greatly in performance and capability in the past few years. One consequence of this improvement has been a rapid transition to computing environments distributed over long distances, in which users working at powerful but relatively inexpensive workstations can remotely access large supercomputers and database servers at a few centralized locations.

These environments are leading to versatile new approaches to multiple party interactions in which people can participate from afar—including classroom education, medical treatment, collaborative engineering projects, and scientific experiments—and are serving as the model for information dissemination nationwide. Sandia, uniquely positioned with two widely separated major locations, has already moved to such a model by centralizing its supercomputers at Albuquerque under its supercomputer consolidation project. This effort, which provides ready access to Sandia's supercomputers and storage servers from both the California and New Mexico locations, will result in substantial savings in the cost of computing resources and has permitted us to develop the technology base for a robust information infrastructure both within and outside Sandia. For example, we developed a DS3 (45 megabits per second) delay and error simulator that we used to design and test our intersite network in the laboratory. As a result, the network worked the first time when installed in the field.

This work, as well as our other networking activities, will enable Sandia to play a major role in creating an information infrastructure that will place the United States in a position to compete in a global information-based society. Our capabilities in networking and communications were acknowledged by the Interop Achievement Award for excellence in implementing the most sophisticated multivendor corporate internetwork, and for making the most effective use of internetworking technology to further our business goals.

Information surety is concerned with protecting information from unauthorized access, unauthorized accidental modification, and loss of access. This field has been and will continue to be an essential discipline for Sandia's responsibilities in command and control of nuclear weapons. Consequently, we have developed extensive capabilities in information surety at Sandia. These capabilities include the following: design and analysis of cryptographic algorithms and

protocols; adversarial analysis of hardware, software, and total systems; design and analysis of access control systems; development of high-speed communication network security systems; development and fielding of use control systems; development and testing of tamper-resistant technologies; testing of biometric identification techniques; and development of computer security techniques. We regard our synthesis of these capabilities in one organization as a differentiating strength.

## Project Initiatives

### **Computational Manufacturing**

*(for the Assistant Secretary for Defense Programs [program GB])*

Realistic simulation of product, process, and production is one of the key capabilities in realizing information-driven manufacturing. The nuclear weapons complex will require increased use of computational systems design, simulation of prototyping and manufacturing processes, and simulation of system performance and reliability under design conditions and in response to abnormal environments. Thus, the development of rapid prototyping and agile manufacturing techniques must build on emerging simulation capabilities so advanced that they enable virtual prototyping and processing and, ultimately, computational design of entire systems. These technologies depend on Sandia's new thrusts in developing engineering simulation environments.

New, user-friendly, powerful environments are beginning to combine solid modeling, automatic mesh generation, and domain decomposition for parallel processing with algorithms for heat transfer, materials mechanics, fluid flow, and chemistry. Techniques being developed for real-time, desktop visualization of simulation data will be important additions to the engineer's computational tool kit.

The needs of the nuclear weapons complex are mirrored in US industry, where requirements for ever-diminishing product development cycles demand constant innovation. Today and tomorrow, one of the most important advantages will come from the use of computational virtual prototyping of processing tools. Sandia's leading-edge, high-performance computing simulation capabilities are already being transferred to US industry in partnerships facilitated by cooperative research and development agreements. Our computational simulation capabilities are a major research and development resource for American industry.

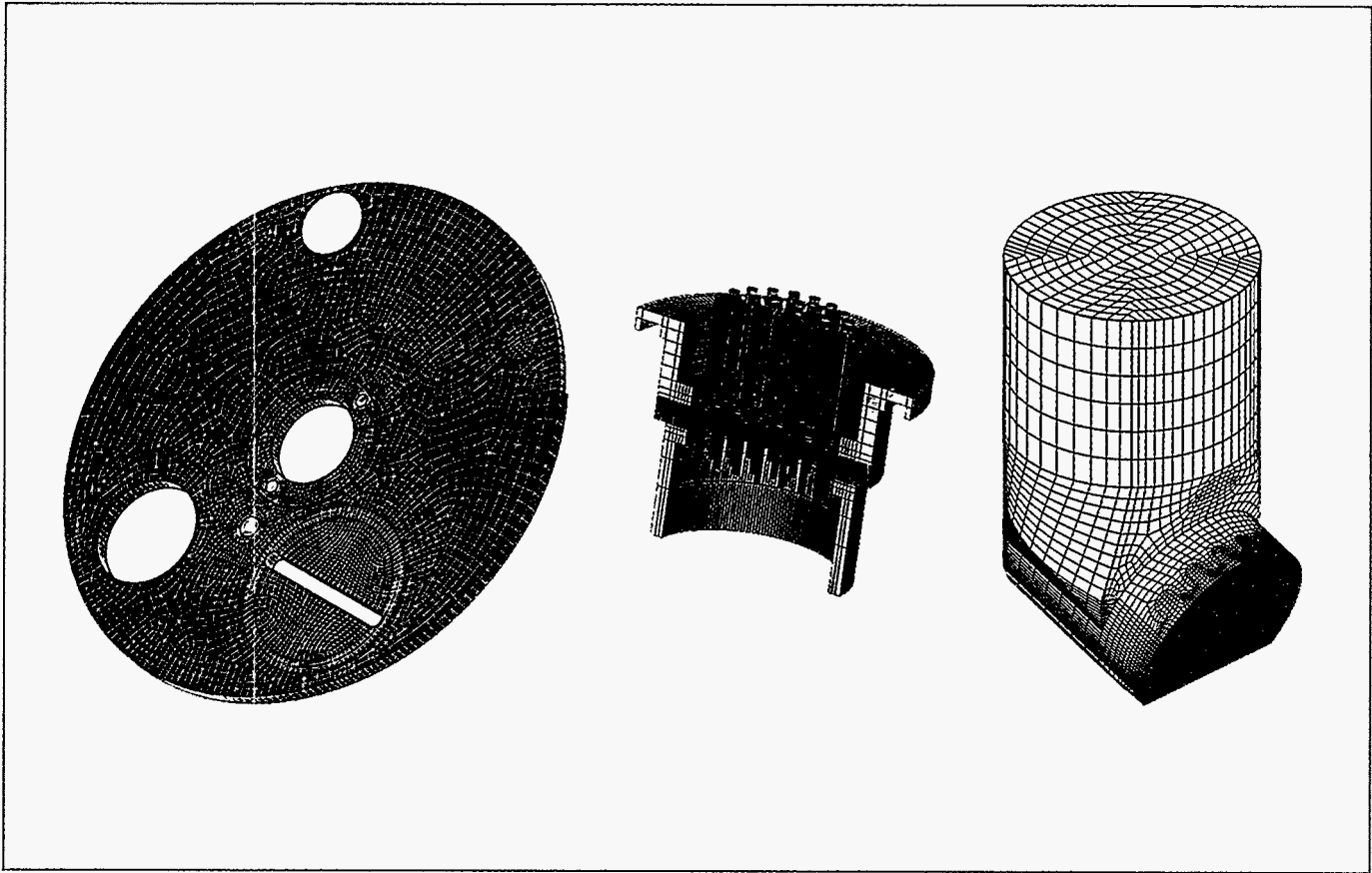

Sandia's simulation experts have developed new algorithms that allow for rapid virtual prototyping. Automatic mesh generation enables designers to model complex three-dimensional surfaces such as (left to right) a safeing wheel, lightning arrester, and wellbore bit.

### **Center for Industrial High-Performance Computing Applications**

*(for the Assistant Secretary for Defense Programs [program GB])*

The Massively Parallel Computing Research Laboratory is rapidly becoming a major center for industrial applications of high-performance computing and communications. More than a dozen cooperative research and development agreements (CRADAs) have already been funded for high-performance computing technology partnerships with US industry in the first year of the DOE Defense Programs' Technology Transfer Initiative.

These CRADAs and some conventional work-for-others agreements include leadership of a major initiative in computational materials and a major partnership with industry to develop new massively parallel database technologies and massively parallel operating systems.

Advanced simulation techniques are being applied to new problems in biology, including development of new defibrillation techniques and design of new pharmaceuticals. Innovations for scientific and engineering simulations are finding new application in the field of volumetric medical imaging for diagnosis and surgical intervention and are the basis of several partnerships with the health care industry.

New thrusts in discrete mathematics are having both scientific and industrial impact and will play a major role in developing the new national information infrastructure. They include combinatorial methods for computational biology and many kinds of networks. Research in surety, security, and privacy for communications and computing is anticipating the needs of "info-America" and is finding immediate application in the financial and medical industries.

Advances in high-performance computing and communications technologies are providing revolutionary new capabilities for designing and optimizing

---

products. These technologies are already a key to numerous Sandia partnerships with companies in the computer, microelectronics, manufacturing, health care, energy, and environment industries, and they support all of Sandia's core competencies and program sectors.

The Center for Industrial High-Performance Computing Applications will help coordinate and foster the development and application of critical high-performance computing and communications technologies at Sandia's many designated and undesignated user facilities, such as the Massively Parallel Computing Research Laboratory, the Center for Computational Engineering, the Combustion Research Facility, the Center for Microelectronics Technologies, the Advanced Manufacturing Center, and the National Center for Advanced Information Components. The center will help form interdisciplinary teams to solve nationally important problems and will accelerate the development of software through expanded collaborations.

This initiative positions the Massively Parallel Computing Research Laboratory to provide industry with access to comprehensive assistance in high-performance computing. The center will strengthen Sandia's role as executive director of the DOE Forum for Industrial High-Performance Computing with a mission to act as the point of contact for industry regarding computing and to develop software interoperability for massively parallel machines in partnership with industry.

### ***Metacomputing Environment and Tools*** *(for the Office of Energy Research [program KC07])*

The next major phase of our distributed computing and networking program expands to include optimization of the communications stack and development of a software super architecture to integrate the distributed components into a transparent system. In this next phase, we will apply the experience gained from our current work to the design of a communications stack optimized at all levels: protocols, message passing libraries, and the underlying hardware.

This work will increase the range of applications that will achieve optimal performance in a distributed environment. Simultaneously, we will investigate methods for supporting an architecture that incorporates the elements of our distributed infrastructure in an object-oriented framework to permit rapid prototyping and flexible support of information science applications. The environment will contain tools that can be collected for processing a problem. Networking software and communication capabilities will allow the rapid and transparent movement of data among software tools.

By utilizing object-oriented techniques, these software tools will be suitable for a wide range of applications. This environment will reduce costs by accelerating software development, increasing the reuse of software,

and decreasing software maintenance. The metacomputing environment will be used for distributing and controlling software, assigning multiple computers to a task, and obtaining information from multiple sources for a task.

Our technology transfer activities range from applications with partners such as Alcoa and Ellery Systems Software to technology infrastructure with such partners as Fore Systems, Digital Equipment Corporation, Hewlett-Packard, Sun Microsystems, IBM, and AT&T. We are collaborating with industry to ensure the highest quality and broadest applicability of the resulting products.

### ***Information Surety***

*(for the Assistant Secretary for Defense Programs [program GB])*

Sandia is applying its outstanding capability in cryptology and command and control to new problems of national importance. Information surety is an essential technology for the development of the national information infrastructure and a national electronic commerce system. In an information economy, the value of information will be such that information will become a lucrative target for criminals and national adversaries. It will be necessary to develop a national information security system and to constantly reassess vulnerabilities and improve the security of the system in light of unpredicted advances in technology.

Sandia is well-positioned to lead a national research and development effort in information surety. Projects have been started to develop the high-speed network security systems that will be required. US industry has already shown an interest in collaborating with Sandia to develop technologies to provide security for computerized medical records and to assess and improve the security of financial transactions.

As the DOE nuclear weapons complex moves toward agile manufacturing, information surety will play a critical role. Moreover, this area will continue to be essential for Sandia's responsibilities in command and control of nuclear weapons. One of the many technologies that must be developed is a robust method for identifying individuals, either in person or remotely. An identification card could be designed that prevents impersonation by combining cryptography, tamper-resistant data storage, and biometric identification. Such a card could improve the security of many current identification needs: credit and other bank cards; controlled access to secure facilities; shopping, banking, and voting by telephone; and access to sensitive information. Sandia could develop identification methods that would satisfy the demands of all of these applications and reduce fraud.

---

## ***National Information Infrastructure Test Bed*** *(for the Assistant Secretary for Defense Programs [program GB])*

The US government is committed to accelerating the development of information technologies and a national information infrastructure that will respond to the economic and social demands of the twenty-first century while meeting the needs of DOE missions in nuclear weapons, energy, environment, and education. We are collaborating with industry, universities, and other government laboratories to establish a nationwide high-performance test bed to develop and evaluate the performance and interoperability of networking technology and distributed computing applications for the national information infrastructure.

The test bed will facilitate exchange of precompetitive information and practical experience on information technologies and applications. It will expedite and support near-term implementation of the national information infrastructure as an active collaboration of US industry, government, and universities. This initiative builds directly on our capabilities in distributed computing and networking and is ultimately connected to our interests in metacomputing environment and tools.

## ***Technology Information Environment for Industry***

*(for the Assistant Secretary for Defense Programs [program GB])*

A new tool for technology transfer, the technology information environment for industry (TIE-In), is being developed at Sandia. The two primary goals of TIE-In are to increase the leverage of DOE technology transfer efforts with a system that can reach hundreds or thousands of businesses and to reduce the investment required by industry to utilize national laboratory technologies.

TIE-In will use advances in information and computer technologies to electronically guide users through the process of obtaining solutions. This will provide leverage for DOE by minimizing direct staff interaction with users. It will also minimize the required industrial investment by relieving users of the need to obtain or maintain specialized technical expertise and equipment.

TIE-In will be supported by a user facility that operates as an electronic extension service to allow users to obtain solutions to problems from remote locations. These users would not require specialized technical expertise, nor would they incur the very large expenses associated with employing specialized analysts, maintaining software libraries and a software maintenance staff, developing custom databases, and purchasing and

operating high-performance computing and experimental equipment.

## ***Massive Data Processing, Storage, and Management***

*(for the Assistant Secretary for Defense Programs [program GB])*

On-line, high-speed access to distributed multiterabyte databases can allow new paradigms for scientific and engineering collaboration, for interacting with computational simulations, and for disseminating scientific and computational results. The infrastructure for storage, query, search, and retrieval of mixed media (large-scale numerical data, graphics, and video) databases remains to be developed.

A project at Sandia is needed to maximize return on such computational simulation initiatives as TIE-In and Sandia's leadership role in the National Consortium for High-Performance Computing. The effort will develop

- software for efficient manipulation and querying of mixed media data,
- technology for seamless interoperation of storage servers distributed around the country,
- associated user and high-speed network interfaces to enable users to interact with data in new ways,
- standards in concert with appropriate commercial and government entities, and
- software algorithms for "fuzzy" searches on large databases (e.g., to retrieve text that has a close association but in which the key words are not identical to the query).

These technologies will be incorporated in interfaces for massively parallel servers (including the Intel Paragon and nCUBE 3 supercomputers), collaborative research and development with industrial partners such as Oracle Systems Inc., and major research universities such as the Massachusetts Institute of Technology, Stanford University, and the University of California.

The concept of data, traditionally regarded as text and numbers, has been broadened to include text, graphics, video, sound, animation, and the temporal links between data types during presentation to the end user. In addition, high-performance computing and distributed processing will lead to orders-of-magnitude increases in the volume and geographical distribution of data associated with any particular event. New techniques are needed to efficiently store such multimedia data so that they are also transparent to the end user. Such techniques

must include methods to store data as a conglomerate of different types and to allow distributed locations of individual components. These techniques must also provide fetch, store, and translation mechanisms for a wide variety of computing equipment and must rely on high-performance communication networks to make data location irrelevant. New techniques are also needed to search through very large databases from many sources. Searches must be smart enough to understand context and identify desired associations of synonymous words, names, abbreviations, etc.

### Wireless

(for the Assistant Secretary for Defense Programs [program GB])

Wireless technology will play a key role in future multimedia communications. It is an important component of providing mobility and quick setup in locations devoid of other communications. It may also be the only way to provide reliable communication with individuals who move about but must be monitored for purposes of

control (e.g., offenders who do not require incarceration) or protection (e.g., individuals with high-risk medical conditions).

Today's cellular phone technology illustrates this kind of portability but is incapable of supporting the high bandwidths and global availability required for the multimedia applications now emerging. Today's wireless technologies must be enhanced to provide high-bandwidth secure communications, high reliability, and global availability while minimizing the weight, power, and possible health risks associated with the use of such portable communication terminals. Other required advances in technology include

- efficient methods of frequency sharing and reuse;
- compression techniques for video and image data;
- efficient cryptographic techniques to ensure privacy, integrity, and authenticity of communications; and
- integration into larger, nonportable, multimedia communication systems.

**Funding Requirements for Initiative Project Proposals in  
Advanced Information Technology  
(Dollars in Constant FY 1994 Millions; Personnel in FTEs)**

	<u>Year 1</u>	<u>Year 2</u>	<u>Year 3</u>	<u>Year 4</u>	<u>Year 5</u>
Computational Manufacturing					
Operating	4.0	6.0	8.0	8.0	8.0
Capital Equipment	1.0	0.5	1.0	0.5	0.5
Total Cost	5.0	6.5	9.0	8.5	8.5
Direct Personnel	12	15	20	20	20
Center for Industrial High-Performance Computing Applications					
Operating	4.0	5.0	6.0	8.0	9.0
Capital Equipment	1.0	20.0	1.0	20.0	1.0
Total Cost	5.0	25.0	7.0	28.0	10.0
Direct Personnel	10	15	20	25	30
Metacomputing Environment and Tools					
Operating	7.0	9.0	10.0	10.0	10.0
Capital Equipment	1.0	1.0	1.0	1.0	1.0
Total Cost	8.0	10.0	11.0	11.0	11.0
Direct Personnel	25	30	35	35	35

**Funding Requirements for Initiative Project Proposals in  
Advanced Information Technology (Continued)**  
(Dollars in Constant FY 1994 Millions; Personnel in FTEs)

	<u>Year 1</u>	<u>Year 2</u>	<u>Year 3</u>	<u>Year 4</u>	<u>Year 5</u>
Information Surety					
Operating	9.0	11.0	11.0	11.0	11.0
Capital Equipment	0.5	0.5	0.5		
Total Cost	9.5	11.0	11.5	11.0	11.5
Direct Personnel	35	40	40	40	40
National Information Infrastructure Test Bed					
Operating	6.0	8.0	9.0	9.0	9.0
Capital Equipment	1.0	1.0	1.0	1.0	1.0
Total Cost	7.0	9.0	10.0	10.0	10.0
Direct Personnel	20	25	30	30	30
Technology Information Environment for Industry					
Operating	7.0	9.0	10.0	10.0	10.0
Capital Equipment	0.5	0.5	0.5	0.5	0.5
Total Cost	7.5	9.5	10.5	10.5	10.5
Direct Personnel	25	30	35	35	35
Massive Data Processing, Storage, and Management					
Operating	3.0	3.0	4.0	4.0	4.0
Capital Equipment	1.0	1.0	1.0	1.0	1.0
Total Cost	4.0	4.0	5.0	5.0	5.0
Direct Personnel	10	10	15	15	15
Wireless					
Operating	4.0	4.0	4.0	6.0	8.0
Capital Equipment	0.5	0.5	0.5		
Total Cost	4.0	4.5	4.5	6.5	8.0
Direct Personnel	10	10	10	20	20
<b>Total, Advanced Information Technology</b>					
Operating	44.0	55.0	62.0	66.0	69.0
Capital Equipment	6.0	24.5	6.5	24.5	5.5
Total Cost	50.0	79.0	68.5	90.5	74.5
Direct Personnel	147	175	205	220	225

---

## Transportation Energy Technology and Infrastructure

Improving the nation's economic competitiveness will depend heavily on greater energy efficiency and transportation modernization of US industries. Advances in these areas should be pursued through an integrated initiative because transportation accounts for a large portion of national energy consumption.

The transportation system's exclusive reliance on petroleum fuels makes the nation vulnerable to oil shortages and price shocks. This problem can be reduced by the development of cost-competitive alternative fuels such as hydrogen and methanol and greater use of natural gas and electricity. Improving transportation energy consumption by improving the efficiency of vehicles and the transportation system will also be necessary.

Although federally mandated reductions in vehicle emissions have been achieved during the last twenty years, the Department of Transportation (DOT) forecasts that total emissions will begin to increase after 1996. Despite the fact that more stringent fuel efficiency standards will be in effect, this reversal will occur because vehicle miles traveled will increase faster than improvements in fuel efficiency. Federal air quality standards cannot be maintained in the long term unless significant changes occur in urban transportation systems.

The safety and efficiency of the transportation infrastructure can be greatly improved. Americans now lose over two billion work hours per year from traffic congestion, and several major cities forecast dramatic decreases in average freeway speeds over the next several years. Transportation issues are closely tied to improving national economic competitiveness and will have an even greater impact in the coming years. A growing and changing economy is significantly affected by the availability and cost of transportation. Transportation systems that impose a relatively high burden on US producers will not be competitive. Japan and Europe have already begun to aggressively modernize their transportation systems.

Technological innovation is needed to ensure a secure and prosperous future. The legislation to address these needs is the Intermodal Surface Transportation Efficiency Act of 1991. This act sponsors the creation of the nation's future transportation system and encourages the DOT to enlist DOE's national laboratories in this task. The nation's transportation problems can be solved by an approach that integrates and applies the talents of the DOT, the DOE national laboratories, and industry.

Sandia has conducted lead functions in transportation for DOE for four decades. These functions are broad, serving several DOE customers and benefiting from

synergy in several areas.

Since its inception, Sandia has been the lead laboratory for transportation technologies associated with the safe, reliable, and monitorable movement of defense hardware. This historical role includes infrastructure issues in geographic information system tracking of trucks, full vehicle system design and production oversight, and reliability and safety integration. For nearly twenty years, we have held a similar lead role for transportation systems for radioactive and hazardous materials for both DOE and DOT. This role has involved infrastructure issues, including the geographic information system, cask design and certification, safety, performance assessment, and manufacturing. These two missions have also allowed Sandia to play important roles internationally in transportation of special materials in the former Soviet Union and in ocean and air transport of reactor fuel around the world.

Sandia's energy-related transportation responsibilities have been focused on lead laboratory responsibilities in engine combustion technology and advanced batteries. The engine program is a model government/university/industry partnership and has demonstrated to industry the valuable contributions the national laboratories can make. Because of these successes, the US auto industry is seeking Sandia's participation in their recent thrusts for improvement. In the past year, numerous cooperative research and development agreements have been placed by Sandia and the auto industry.

Because of these broad system successes at Sandia (information systems, propulsion systems, storage systems, vehicle system design and manufacture, reliability and safety integration, and multilaboratory coordination), we intend to play an even larger role in the US transportation infrastructure and vehicle system technology development. Our historical competency in systems integration and our experience in transportation should be utilized by the departments of Energy and Transportation to maximize mission successes. Sandia's core competencies can be used to obtain practical solutions to transportation problems.

### Project Initiatives

#### *Transportation Energy and Environment Technology*

*(for the Assistant Secretary for Energy Efficiency and Renewable Energy [program EE])*

Sandia's Advanced Transportation Energy and Environment Technology Program is focused on improving the energy efficiency of the US transportation system, thus improving the country's economic competitiveness while protecting the environment. To this end, Sandia has entered into a number of CRADAs with industries

connected with transportation, notably the United States Council for Automotive Research and the United States Advanced Battery Consortium, which is developing an improved battery for electric vehicles.

Sandia's Engine Combustion Technology Project works to develop new technologies to improve efficiency, increase fuel flexibility, and reduce emissions in automobile and truck engines. The transportation materials initiative includes catalysts for emission reduction and fuel cell applications, lightweight structural materials, hydrogen storage materials, and other new engineered materials for transportation applications. The initiatives discussed below provide a foundation for expanded effort in developing energy-efficient transportation.

### ***Advanced Energy Storage***

Sandia has considerable expertise in energy storage development, which includes carbon materials for double-layer capacitors and sodium/sulfur and zinc/air batteries. Much of this expertise is being applied in supporting the United States Advanced Battery Consortium (USABC), with participation by the Electric Power Research Institute and industry. USABC was formed to develop advanced batteries for commercial use in electric vehicles by 1998. The California initiative requiring a percentage of vehicles sold in 1998 to produce zero pollution was a stimulus for formation of the group. Sandia's role with the USABC includes materials development, battery design, and testing.

### ***Hybrid Vehicles***

Hybrid vehicles powered by batteries or fuel cells in conjunction with each other or with an internal combustion engine also will contribute to fuel substitution and environmental protection. Sandia's battery technology base, combustion expertise at the Combustion Research Facility (Sandia/California), and systems engineering capabilities provide the tools necessary to this program.

### ***Alternative Fuels***

Optimizing engine designs for emissions control and high efficiency is important to the expanded use of hydrocarbon fuels. Wider use of natural gas or multifuel engines will also support expanded use of such fuels. Sandia's Combustion Research Facility supports this work and can play a key role in solving these problems. In addition, our expertise in catalysis can contribute to the direct use of alternative fuels in fuel cells, and our experience in storing and transferring hydrogen isotopes (gained in the nuclear weapons program) can contribute to the practical utilization of hydrogen as a fuel.

## ***Transportation Infrastructure Technologies*** *(for the United States Department of Transportation)*

The Department of Transportation is beginning a program to improve the safety and efficiency of surface transportation by applying the latest technology in sensors, data fusion, communications, information, and control. The interconnections among various modes of transportation will become increasingly important in future systems. The Intelligent Vehicle and Highway System program envisions "smart" highways and vehicles that will improve safety and reduce congestion, energy consumption, and pollution. The technology involves vehicle tracking systems, collision avoidance sensors, traffic control centers, automatic vehicle control systems, and roadside sensors.

In addition, new programs to enhance public transit systems, railroad systems, and commercial vehicle operations can be uniquely supported by Sandia's system integration capabilities. A current initiative directs Sandia's core competencies toward practical solutions for these transportation infrastructure problems. Research and development will be conducted in several areas in conjunction with the private sector and universities to foster rapid development and commercialization.

### ***Systems Analysis***

Future transportation systems will need to balance the interrelated issues of energy security, environmental quality, cost, and efficiency. It will be prudent to perform systems analyses before making major commitments or allocating resources to technology development and commercialization. Sandia's experience in modeling and analysis will help to analyze all levels of system design.

The current study to examine the technical and economic feasibility of the proposed Santa Teresa Intermodal Facility is a prime example of this type of effort. This facility would cover approximately ten square miles near the border of New Mexico and Mexico and could dramatically improve the efficiency of moving commercial vehicle freight across the border.

### ***Alliance for Transportation Research***

Sandia has established a partnership with the University of New Mexico, New Mexico State University, Los Alamos National Laboratory, and the New Mexico State Highway and Transportation Department for transportation research. The alliance is a unique combination of partners with wide-ranging technical capabilities and facilities and a thorough understanding of current problem areas and future needs for the nation's transportation infrastructure. The alliance is dedicated to solving the nation's transportation needs by teaming with other



---

research organizations and industry in application-oriented research and development.

### ***Transportation System Risk Assessment***

The selection of tomorrow's transportation systems involves a thorough understanding of risks associated with the introduction of new fuels and energy storage elements into the system.

The extensive use of combustible fuels in the United States leads to a variety of safety and security concerns. Combustible fuels include both fossil fuels (petroleum and petrochemical products) and biomass fuels (alcohol, methanol, vegetable oils, wood, manufacturing waste, and garbage). Accidents related to the use of combustible fuels occur frequently. The resulting loss of life is unnecessary; the economic and environmental costs are large.

To ensure against abnormal occurrences, misuse, or sabotage, systematic risk assessment and testing should be conducted on every step of the combustible fuel system: extraction, transportation, storage, processing, and consumption/disposal. Each step is subject to environmental, safety, and health (ES&H) risks because dangerous work sites such as offshore oil platforms, pipelines, transport vehicles, storage tanks, processing plants, and disposal facilities are all part of the process of preparing fuel for consumption.

Sandia can help DOE regulate the nation's energy supply and also help the Department of Transportation ensure ES&H compliance. We are well-positioned to conduct risk assessment studies and testing from a systems point of view, addressing both safety and security. As the originator of probabilistic risk analysis methodologies for nuclear power systems and nuclear weapons, we can apply these techniques to economic issues and risk-related scenarios.

Sandia's capabilities can be useful in an integrated transportation initiative combining the technology for energy sources and system solutions for tomorrow's transportation infrastructure.

### ***Intelligent Vehicle and Highway System***

Much of the technology for the Intelligent Vehicle and Highway System (IVHS) is an extension of work already under way at DOE laboratories. The Safe Secure Transport program has developed reliable, secure systems for transporting nuclear weapons and materials. DOE has developed a command and control system called STAR-BASE to operate and manage the fleet and provide emergency response. The Department of Transportation has expressed interest in using our experience base to develop a geographic information system for transportation to collect and manage the vast amount of information that will be generated by the legally mandated upgrades to the transportation infrastructure. These technologies are also important to

managers of large truck or bus fleets.

Sandia has developed many types of robust, unattended ground sensors. This technology may be important to the IVHS program in developing roadside sensors for monitoring commercial vehicle safety, assessing the weight of passing trucks, and automatically assessing tolls. We have also developed many versions of teleoperated and autonomous vehicles.

### ***Partnership for a New Generation of Vehicles*** *(for the Assistant Secretary for Defense Programs [program GB])*

The Partnership for a New Generation of Vehicles (PNGV), the new name for a program also called clean car or super car, was announced in September 1993 by President Clinton and the chief executives of Ford, General Motors, and Chrysler. The program enables a new partnership between the US government and the domestic automobile industry to improve economic competitiveness, the energy supply, and the environment. Automobiles were selected because of their role in personal transport, environmental cleanliness, and economic competitiveness.

The program focuses on technologies that can reduce the time and cost for moving new automotive product ideas into the marketplace—technologies that will enhance the safety and efficiency of the present designs of automobiles and that will be required to develop production prototypes of vehicles with up to three times greater fuel efficiency than today's vehicles.

Sandia has established capabilities in combustion analysis and instrumentation, sensing, analysis and control of manufacturing processes, development and application of lightweight materials, supercomputing, structural analysis, fluid dynamics, mesh generation, and visualization. These capabilities have been nurtured primarily to meet the requirements of our nuclear ordnance mission, but they have also been supported by the Basic Energy Sciences, Energy Efficiency, and Environmental areas of DOE. Building on these capabilities, we have used the technology transfer initiative process to open new programs with the auto industry.

The US Council for Automotive Research (USCAR) is the US automobile industry's body for performing and sharing precompetitive, cooperative research of mutual interest to Ford, General Motors, and Chrysler. USCAR is organized into about twelve consortia that address various technical areas. For example, emissions control technologies are addressed by USCAR's Low Emissions Partnership, and advanced, lightweight materials are addressed by USCAR's Advanced Materials Partnership. Other consortia consider the technical issues related to recycling, supercomputing, computer-aided design/computer-aided manufacturing, emissions measurement,

painting, and advanced batteries for electric or hybrid automobiles. USCAR is the industry's organization for participation in the PNGV.

Three major areas of emphasis in Sandia's automotive initiative, which correspond to the major areas selected by USCAR:

- advanced emissions control technologies,
- lightweight materials for automotive applications, and
- advanced supercomputing.

Sandia's Advanced Manufacturing Technology Program has major applications to the automotive industry. Many of the projects in process analysis, quality, reliability, and environmental areas find important automotive application. Other Sandia efforts that contribute to the initiative are

- advanced design techniques for tire design and manufacture,
- improved combustion systems, and
- fuel cell development and manufacture.

**Funding Requirements for Initiative Project Proposals in Transportation Energy Technology and Infrastructure  
(Dollars in Constant FY 1994 Millions; Personnel in FTEs)**

	<u>Year 1</u>	<u>Year 2</u>	<u>Year 3</u>	<u>Year 4</u>	<u>Year 5</u>
Transportation Energy and Environment Technology					
Operating	6.0	10.0	15.0	20.0	20.0
Direct Personnel	15	25	37	50	50
Transportation Infrastructure Technology					
Operating	5.0	10.0	15.0	20.0	20.0
Direct Personnel	10	15	20	25	25
Partnership for a New Generation of Vehicles					
Operating	20.0	30.0	45.0	60.0	80.0
Direct Personnel	50	70	80	120	130
<b>Total, Transportation Energy Technology and Infrastructure</b>					
Operating	31.0	50.0	75.0	100.0	120.0
Direct Personnel	75	110	137	195	205

## Environmental Technology

Environmental issues are a growing national and international concern. Unfortunately, technologies for dealing with environmental problems are often immature or costly. DOE has a major responsibility for developing and applying environmental technologies and sharing solutions with industry and other agencies. Seeking to support DOE and the nation in this endeavor, Sandia has initiated a program to apply its wide range of technical competencies to environmental issues.

Sandia has an extensive base of experience in environmental technologies, particularly with systems for transporting and storing radioactive waste. For many years, Sandia has had a major responsibility for testing and performance assessment for the Waste Isolation Pilot Plant repository. We also serve as DOE's lead laboratory for conducting the assessment of compliance for Greater Confinement Disposal at the Nevada Test Site. Several DOE offices share research expertise for these assessments, which are coordinated through DOE's Office of Waste Management.

Since 1978, Sandia has been the DOE center for research and development for packaging and transporting radioactive materials. These efforts have been associated chiefly with waste management aspects of DOE programs, but the technology has found application in DOE Defense Programs, Naval Reactors, and Nuclear Energy programs as well. In addition, other agencies have funded aspects of the program such as design of packaging for moving chemical munitions to demilitarization sites, development of routing guidelines, evaluation of safety program operations, and development of performance standards for toxic inhalants.

In 1990, Sandia assumed a lead role in moving the DOE production complex toward environmentally conscious manufacturing for nonnuclear components. We have developed and introduced suitable substitutes for materials and processes that required or generated hazardous wastes.

For many years, the DOE Combustion Research Facility at Sandia/California has investigated the mechanisms that create pollutants in combustion processes and has developed concepts for cleaner energy conversion processes. The solar thermal program at Sandia/New Mexico has helped develop an innovative process for destroying organic compounds in wastewater using solar energy. Competencies developed in defense and energy programs form a useful foundation for environmental research and technology development.

In 1993, DOE asked Sandia to provide technical management for a new joint DOE and Environmental Protection Agency program investigating a streamlined process for demonstrating innovative cleanup technologies for contaminated sites. This program is being viewed as a model cooperative effort among industry, regulators, and federal agencies. Plans call for extend-

ing this partnership to many DOE site cleanup problems, as well as to a variety of waste management issues.

## Project Initiatives

### *Waste Management*

*(for the Assistant Secretary for Defense Programs [program GB], the Assistant Secretary for Energy Efficiency and Renewable Energy [program ED], and the Office of Environmental Restoration and Waste Management [program EW])*

New waste management technologies are needed to address both regulatory and political requirements. In partnership with industry and other national laboratories, Sandia is actively involved in developing treatment and disposal processes and recycling techniques. These activities address both Sandia's obligations for handling its own wastes from current and past operations, and technologies for application to national needs.

One set of problems involves disposal of electronic packages resulting from weapons dismantlement. Extending our waste-management technologies for these components to commercial electronics is a major goal of our current activities. In the future, there will be great demand for advanced waste management technologies. As a nation, we are faced with an ever-growing need to deal with waste plastics, municipal wastes, hazardous chemicals, and obsolete electronics. In addition, many government agencies, including DOE and DoD, are faced with challenging requirements for handling radioactive wastes, high explosives, propellants, and chemical wastes.

For radioactive wastes, strategies that use a full suite of techniques for pretreatment, characterization, recycling, minimization, stabilization, and storage will need to be explored. For hazardous wastes (such as high-explosive propellants and chemicals) special treatment issues must be addressed. Waste management technologies will be needed to solve both social and technical issues: public acceptance; regulatory compliance; sample waste characterization, monitoring, destruction or treatment techniques; risk assessment and risk management; stabilization and minimization; liability; and cost.

Many Sandia-developed technologies will be applied to these issues. We plan to extend our expertise in robotic systems, radioactive materials safety, intrusion systems, chemical and thermal processing, risk assessment, and sensor systems to solve these problems. Because so many waste management problems facing DOE are similar to those faced by the nation as a whole, we hope to use our technologies to solve many of the waste management problems faced by industry.

---

## **Environmental Restoration**

*(for the Assistant Secretary for Defense Programs [program GB] and the Office of Environmental Restoration and Waste Management [program EW])*

Environmental restoration focuses on the cleanup of contaminated sites. Technologies and systems that lead to quicker, safer, and more efficient remediation of sites are needed. Literally tens of thousands of suspected contaminated sites are the responsibility of DOE and DoD, in addition to problems on lands administered by the departments of agriculture and the interior. Also, virtually every municipality must deal with contamination from industrial or extractive activities.

In the future, more efficient ways to clean up contaminated sites will be needed. Advanced sensing systems involving airborne or even space-borne sensors, together with rapid sampling and analysis techniques providing real-time data on the extent of contamination, may be useful. Because the cost of cleanups will continue to rise, there will be a need for more cost-effective solutions using publicly acceptable waste stabilization and barrier technologies that have high reliability and permanence. Technologies to verify the integrity of in situ containment structures and for placement of structures beneath buried waste, tanks, and spills will be needed. Long-term, subsurface dosimetry instrumentation for detecting leakage of hazardous or radioactive substances will be needed to ensure that risk to public health and safety is minimal.

Information is key to making appropriate restoration decisions. Expansion and update of information systems such as the EnviroTRADE database management system will be critical in giving site managers information concerning progress from other sites worldwide. Also key in making timely decisions are tools for assessment of risk and for prioritizing and benefit. Work on such tools will be an important new initiative for Sandia.

The restoration initiative will also focus on problems beyond DOE, including mine tailings, septic tank drain fields, agricultural pollution, and abandoned municipal landfills. As more military bases are closed, techniques for identifying and containing contaminants and performing site cleanup will need to become efficient and be acceptable to regulators and the public. Finally, a growing concern about contamination and restoration of ports, harbors, and marine estuaries will require advanced technologies for characterizing and cleaning up ocean sediments.

Solutions to these problems that balance public health and safety against cleanup costs will become a national priority. Sandia's capabilities in sensor systems, physical and chemical analysis, and systems integration, together with our geophysical experience and knowledge, can directly support such activities.

## **Hazardous Materials Transportation**

*(for the Assistant Secretary for Defense Programs [program GB], the Office of Environmental Restoration and Waste Management [program EW], and the United States Department of Transportation)*

Growing public environmental awareness and risk consciousness focus on governmental activities that have the potential to produce harm. One of the most visible of all such activities is the packaging and transportation of all hazardous materials, not just radioactive wastes.

DOE will be challenged to demonstrate safety as it begins to remediate sites and send wastes to repositories or move materials to permanent disposal areas. For example, interim storage and transportation of unprocessed spent fuel from the nuclear weapons program, as well as research reactor spent fuel that DOE has committed to accept under the Research Reactor Spent Fuel Return Program, constitute a formidable problem. Also, programs in site decontamination and decommissioning are expected to produce large quantities of waste to be moved to repositories.

A growing need exists for careful consideration of the systems aspects of proposed solutions to these challenges. Also needed are innovative package designs, new package materials, and demonstrations of package and operations safety—all of which are key strengths of Sandia's program. New program initiatives are briefly described below.

### **Hazardous Waste Containers**

As DOE remediates sites, Sandia proposes to develop containers to store and transport hazardous and mixed hazardous materials. This effort builds on current expertise but is more demanding because of the requirement to maintain container integrity and elastomeric materials in the face of attack by corrosive and organic solvents that may be components of the waste.

### **Geographic Information Systems**

Applications of geographic information systems as an enabling technology are proposed in risk assessment, routing, and emergency management as an important addition to our existing capabilities. Increased emphasis in DOE on interactions with stakeholders during cleanup campaigns requires the development of geographic information system tools to illustrate actions to be taken and provide the software interface in guiding activity.

### **Multipurpose Containers**

Spent fuel from DOE weapons production and from research reactors will probably not be reprocessed. Instead, interim storage and geological disposal are considered options. We propose to evaluate the multipurpose container as a means of avoiding multiple handling of the fuel, as a consolidation measure, and to facilitate robotic opera-

tions in the repository. This evaluation may lead to a systems study and development of an optimized package.

### ***Electronic Emergency Response Systems***

We are proposing development of a group of rugged, cost-effective sensors to detect accidents, store information about accidents, summon response teams, and provide information and direction to responders. Given the increased awareness and risk-aversion of the public toward hazardous material in the environment, this technology will provide hazardous materials operations with effective tools to help protect the environment in the event of accidents.

### ***Unmanned Aerospace Vehicles for Climate Studies***

*(for the Office of Energy Research [program KC])*

Over the past several years, global climate change and sustainable economic development have come to the forefront of the world's and the nation's science and policy agendas. Although most scientists agree that energy-related emissions will give rise to a man-made warming trend, there is significant uncertainty about the magnitude and timing of this effect and its regional distribution. Policy decisions made in the presence of this uncertainty will have substantial and widespread economic impact, emphasizing the importance of improved understanding of climate change.

Recognizing this need, DOE has initiated the Atmospheric Radiation Measurement (ARM) program. ARM

seeks to improve our understanding of the Earth's solar and thermal radiation with clouds—the dominant uncertainty in current climate models and the top research priority of the United States Global Climate Change Research Program (USGCRP). This highly successful multilaboratory program emphasizes ground-based measurements of radiation and cloud parameters. However, it was recognized from the outset that certain key parameters, such as atmospheric heating and cloud top properties, were best measured in the atmosphere. Furthermore, the desired combination of altitude and endurance capabilities (multiday flights at altitudes up to 20 kilometers) puts these measurements beyond the capability of manned aircraft.

Studies have identified small unmanned aerospace vehicles (UAVs), now being developed by industry, as the most promising way of meeting these needs. In fact the USGCRP has noted that UAVs can address several critical issues that cannot be adequately addressed by any existing ground, aircraft, balloon, rocket, or satellite platforms. The UAVs are said to offer the potential to obtain critical data on important earth science processes in a unique and previously unexplored manner using in situ and remote sensing instrumentation at low costs.

Therefore, using funding from the Strategic Environmental Research and Development Program (SERDP), DOE has initiated a multilaboratory ARM/UAV program under the technical direction of Sandia National Laboratories. This program is developing the necessary instrumentation and measurement techniques needed to capitalize on the small UAVs now being developed by

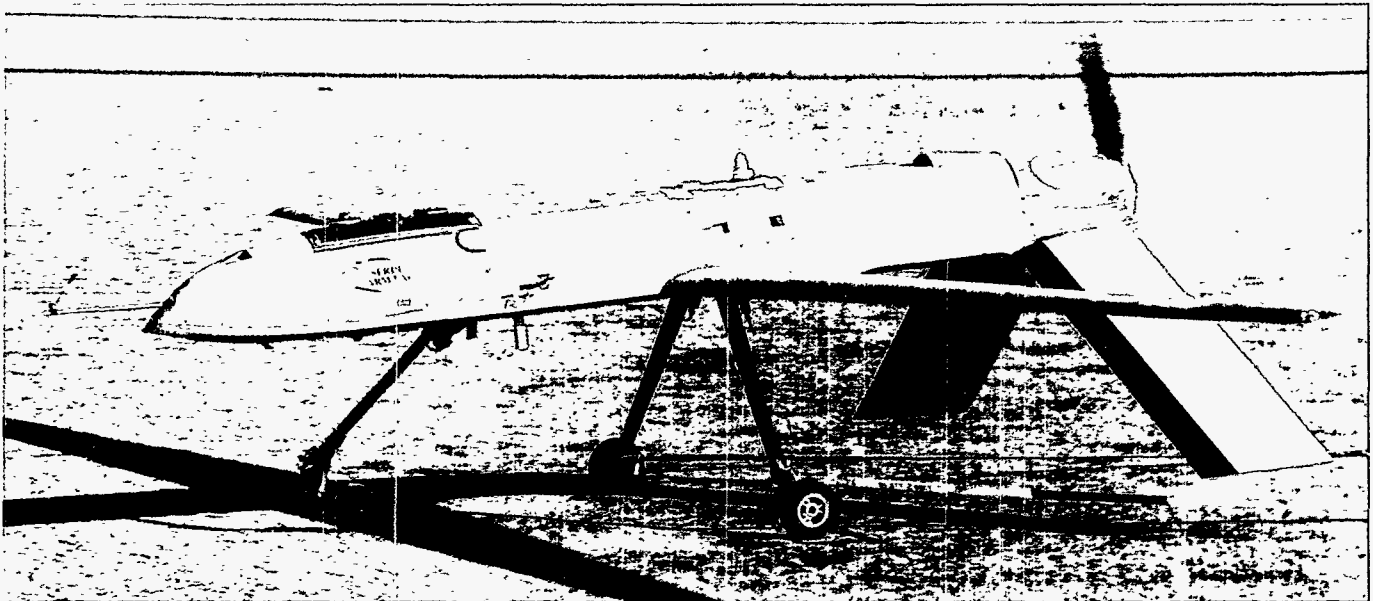

Sandia has developed instrumentation used in this unmanned aerospace vehicle. The Sandia-designed lidar is mounted on the top front of the aircraft and used to measure water vapor and obtain data on important earth science processes.

industry. Successful demonstration of these technologies will also open new markets in environmental and scientific sensing to this emerging sector of the aerospace industry. During FY 1993 and 1994, major progress was made toward these goals. In less than six months, we developed and integrated a baseline radiometric payload for a UAV. On its maiden engineering test flight, this payload worked flawlessly, yielding publishable scientific data—the first-ever climate-relevant measurements from a UAV. Succeeding phases of SERDP will take advantage of higher altitude UAVs being developed by industry, demonstrate the ability to use multiple UAVs for measuring atmospheric profiles, and develop additional instruments to measure cloud and water vapor properties.

SERDP has provided funding to initiate development of these advanced instruments and measurement techniques and will probably continue to fund their development. However, SERDP will not fund the extended operations and measurements (hundreds to thousands of flight hours per year) following the development phase. This operational phase will be required to help meet the DOE goal of reducing the uncertainty in radiation-cloud interactions and, hence, in greenhouse warming predictions.

DOE has an extraordinary opportunity to reap the benefits of the advanced measurement capabilities now being made available. The DOE budgets proposed below reflect the transition from SERDP-funded development to DOE-funded scientific operation.

**Funding Requirements for Initiative Project Proposals in  
Environmental Technology  
(Dollars in Constant FY 1994 Millions; Personnel in FTEs)**

	<u>Year 1</u>	<u>Year 2</u>	<u>Year 3</u>	<u>Year 4</u>	<u>Year 5</u>
Environmentally Conscious Manufacturing Operating	2.0	3.0	5.0	7.0	9.0
Direct Personnel	10	15	20	25	30
Waste Management Operating	7.0	8.0	9.0	10.0	12.0
Direct Personnel	20	25	30	35	40
Environmental Restoration Operating	4.0	6.0	8.0	10.0	14.0
Direct Personnel	10	15	20	25	40
Hazardous Materials Transportation Operating	3.0	4.0	6.0	8.0	10.0
Direct Personnel	6	8	10	12	15
Unmanned Aerospace Vehicles and Small Satellites for Climate Studies Operating	1.0	1.7	7.6	10.5	11.5
Capital Equipment		1.0	2.0	1.0	
Total Cost	1.0	1.7	8.6	12.5	12.5
Direct Personnel	3	4	20	25	25
<b>Total, Environmental Technology</b> Operating	17.0	22.7	35.6	45.5	56.5
Capital Equipment		1.0	2.0	1.0	
Total Cost	17.0	22.7	36.6	47.5	57.5
Direct Personnel	49	67	100	122	150

---

## Energy Research and Technology Development

Energy research and technology development encompasses Sandia's technical capabilities, facilities, and industry relationships. Sandia supports DOE's Global Climate Change Plan and its mission of an integrated approach to improve the competitiveness of US industry, of ensuring the energy security of the nation, and of improving environmental quality. We actively seek opportunities to transfer our expertise and the results of our work to US industry and to the international arena through partnerships with appropriate entities.

A major part of our work is in collaboration with industry to develop system-level solutions to energy and environmental challenges. Sandia has for decades been one of the premier contributors to energy technology in the areas of renewables, fossil energy, and energy efficiency. We are committed to integrating quality into our work processes, and we encourage our partners to do the same. Sandia's technical competencies and systems orientation have traditionally driven our responsibilities in energy technology. For this reason, our chemical sciences effort has focused on developing tools and fundamental knowledge that relate directly to our work with engine, furnace, and fossil fuel combustion. Similarly, our geosciences staff provides basic tools and knowledge to improve our effectiveness in reservoir characterization and repository design. Our materials sciences engineers have a major component of advanced electronic materials design to support our other efforts, such as photovoltaics, advanced semiconductors, and environmentally conscious manufacturing. Sandia uses its technical knowledge and its facilities to help US industry and government agencies improve their energy efficiency, quality, reliability, and cost. We apply these same strengths to energy use, to the sources of energy, and to the technologies related to them.

We are at a threshold of significant new thrusts in renewables, building on our historic strengths in this area. For many years, we have operated the National Solar Thermal Test Facility for DOE. We provide support for the development of Solar Two, a utility-scale solar power tower in California. Sandia's Photovoltaic Systems Design Assistance Center has helped US manufacturers compete in this emerging international market. We are also collaborating with industry and the Bonneville Power Administration to expand commercial utilization of geothermal resources in the Pacific Northwest. Renewable energy technologies rely on Sandia's contributions of reliable, well-engineered system designs to make the leap from laboratory novelties to manufacturable, high-volume commercial products.

Our fossil energy programs have already made numerous breakthroughs in combustion research, coal liquefaction, oil and gas exploration, and reservoir characterization and production. We plan to use our oil

recovery technology partnership as a model for involving industry in other partnership endeavors.

Sandia's nuclear energy program is largely built around our Nuclear Regulatory Commission experience in severe accident phenomenology and risk assessment. We have drawn extensively upon these capabilities and Sandia's broader competencies to assist DOE in its programs in reactor design and in plant life extension. Sandia will continue to help DOE address plant life problems, and we intend to begin a new program in decommissioning and decontamination of plants whose design lifetimes have expired.

Sandia continually uses its capabilities and facilities to improve ongoing programs and suggest offshoots that build on our successes.

### Project Initiatives

#### *Photovoltaics Industry Development*

*(for the Assistant Secretary for Energy Efficiency and Renewable Energy [program EB])*

Drawing upon our wide spectrum of expertise, Sandia has provided the engineering design, testing, and evaluation that have been significant in the development of today's solar energy industry. Important new thrusts are now possible based on this work. The initiatives below will help industry overcome current barriers in manufacturing and infrastructure that keep photovoltaics from becoming a sustainable technology. Sustainability is critical to the photovoltaics industry and is an area where Sandia's technical expertise is vital.

#### *Federal, State, and Regional Government Agency Photovoltaics Initiative*

*(for the Office of Utility Technology)*

This initiative will develop photovoltaic applications for government agencies. Sandia's technical competencies can enable DOE to demonstrate how photovoltaic systems can improve the operational economy of federal and other government agencies. If successful, the initiative will stimulate the local and regional infrastructure for photovoltaic systems, thereby creating jobs and markets for the industry.

For example, cost-effective applications exist today in federal agencies such as the Bureau of Land Management, DoD, Department of Agriculture, and Department of the Interior (parks and remote facilities).

Sandia's Photovoltaic Systems Design Assistance Center, with its proven record of success, will work interactively with agencies to ensure that applications are developed for appropriate needs. In addition, the center will support and complement activities in the established

Photovoltaics for Utilities organization of state working groups. This work will initiate fielding of systems with wide-scale repeatability. It involves state energy officials, representatives from the photovoltaics industry, and staff from utility companies working cooperatively to foster the use of photovoltaics.

### ***Photovoltaic Collector Manufacturing Process Development***

*(for the Office of Solar Electric Conversion)*

A goal of the DOE National Photovoltaic Program is to provide a clean, renewable, and economical source of electric power that will reduce fossil fuel consumption while improving the competitiveness of US industry. To remain internationally competitive, industry must both reduce manufacturing costs and continuously improve the quality of photovoltaic systems.

Manufacturing process development for photovoltaic collectors will improve products and manufacturing processes by collaborating with industry to address manufacturing issues affecting collector durability and cost. Industry has expressed interest in leveraging its limited research and development resources through the analytical services and photovoltaics fabrication capabilities available at Sandia. Sandia's photovoltaic collector lifetime project is already working with several major photovoltaic collector manufacturers to identify mechanisms limiting durability under operating conditions.

Under the proposed initiative, Sandia will investigate issues involving collector design and reliability, collector manufacturing and cost, and environmentally conscious manufacturing of collectors. We will use our laboratory capabilities to fabricate and evaluate collector design and process alternatives, especially in the areas of soldering, encapsulation materials, and bonding.

In addition to using the resources of Sandia's Collector Fabrication and Assembly Laboratory, we will leverage other Sandia centers of expertise: the Photovoltaics Device Fabrication Laboratory for solar cell processing; the Photovoltaics Technology Evaluation Laboratory for environmental durability testing; and the Center for Advanced Manufacturing Technology for environmentally conscious manufacturing, robotics, and advanced manufacturing processes.

This initiative will provide a flexible, industry-oriented support capability that will be responsive to industry's needs as the technology develops and matures.

### ***Photovoltaic Balance-of-System Manufacturing Technology***

*(for the Office of Solar Electric Conversion)*

Approximately one-half the cost of a utility-interconnected photovoltaic energy system is in photovoltaic

modules. The other half is in such balance-of-system items as interconnections, power conditioning, control systems, support structures, and installation.

This initiative addresses balance-of-system technology improvements that will reduce costs and develop hardware to allow US industry to compete successfully in larger markets. A cost-shared, balance-of-system manufacturing initiative will reduce manufacturing costs for photovoltaic power conditioning and control systems. Balance-of-system cost reductions and reliability improvements, coupled with decreases in module costs, will encourage utilities to include photovoltaic generation in grid support, demand-side management, remote power, and other specialized applications.

In addition, development of manufacturable power conditioning and control systems for diesel generator/photovoltaic hybrid systems greater than 100 kilowatts is necessary if photovoltaics is to expand into the diesel replacement market. This market includes systems for village-scale power in developing countries and systems that can meet environmental requirements while supplying power for military and other government applications. This option will be especially attractive in environmentally sensitive areas.

Sandia has collaborated with the US photovoltaics industry to develop systems hardware that has reduced costs, improved performance, and opened new markets both domestically and internationally. This \$50 million initiative will develop the manufacturing capability of the US balance-of-system industry over a five-year period so it can continue to compete in world photovoltaic systems markets. The balance-of-system initiative has strong support from the US photovoltaic industry, which would share program costs.

The Office of Solar Electric Conversion, through the Photovoltaics Division, is funding a Photovoltaic Manufacturing Technology Program to reduce the manufacturing costs of photovoltaic modules. This program is addressing photovoltaic module manufacturing technology problems through cost-shared contracts with photovoltaic module manufacturers. The intent is to reduce the cost of modules by at least half by providing manufacturing technology improvements necessary for the industry to increase production. The photovoltaics industry now recognizes that it will also be necessary to reduce balance-of-system costs if large-scale utility adoption of photovoltaic technology is to become a reality.

### ***Photovoltaic Systems Lifetime Improvement***

*(for the Office of Solar Electric Conversion)*

Ten years of field data from a variety of photovoltaic systems and components show that power loss from balance-of-system degradation typically ranges from 10 to 15 percent and that irreversible module degradation and mismatch losses add another 10 to 15 percent.



---

Because the success of photovoltaic technology will depend on its reliability, the photovoltaic system lifetime improvement effort is aimed at assisting the industry in achieving a photovoltaic technology with a thirty-year lifetime that degrades in performance by less than 10 percent in that period.

A team of representatives from industry, DOE, and users of photovoltaic technologies will work to eliminate the failure mechanisms responsible for power losses now observable in five- to ten-year-old systems. The team will also establish an evaluation program for current manufacturing processes aimed at early mitigation of reliability problems.

The program's working group will perform field evaluations of installed systems and identify causes of observed degradation. Degradation typically includes browning, high resistance in solder bonds, interconnect corrosion, changes in balance-of-systems components' performance, module delamination, cell metallization adhesion, cracks in the back surface polymer, and electrical mismatch.

The working group will recommend improvements in manufacturing processes or in developing new materials to solve reliability problems. It will also recommend utilization of DOE capabilities in photovoltaics testing, materials and process sciences, and nondestructive testing where they can be useful.

The program requires a long-term commitment from both DOE and industry. It will begin with a minimum commitment of \$20 million over a five-year period to address the degradation issues that have surfaced from initial investigations.

### **Utility Photovoltaics**

*(for the Office of Solar Electric Conversion)*

Because utility companies are major suppliers of electricity for the nation, they could be a major customer for photovoltaic systems, using them to supply energy where grid connection is expensive or impossible. This initiative is important in ensuring that utilities use photovoltaics. Sandia can add its technical experience and expertise to demonstrate that photovoltaic systems can be used in a number of ways to help utilities and save the customer money.

This initiative is a cooperative partnership to accelerate the use of photovoltaics within the utility sector. The partners in this effort include the photovoltaics industry, the established utility photovoltaic group; utility representative organizations (such as Edison Electric Institute, American Public Power Association, National Rural Electric Cooperative Association, and Electric Power Research Institute), and individual utility companies.

Objectives are to identify and maximize the benefits of photovoltaics in applied systems for utilities or their customers. These applied systems are developed for a

sustainable, economically driven market. Building on Sandia's established network of relationships with utilities and the photovoltaics industry, higher-value remote and grid-connected applications will offer the photovoltaics industry market entry into the utility sector. The ability of photovoltaic systems to serve remote locations will be the foundation for the transition to larger and significant fuel-offset systems and eventual specialized grid-connected applications. These applications will capitalize on the technology's characteristics of no fuel use, low operating costs, modularity, reliability, and sustainability.

The initiative will be based on the needs of the utilities and their customers. Starting with analyses of feasibility and opportunity, applications will be developed based on current hardware and the ability of photovoltaics to uniquely meet customer requirements for energy in an environmentally acceptable way at the point of use. Furthermore, the systems will to a certain extent bypass traditional means of electricity delivery. Grid-connected systems owned by customers offer a means of demand-side supply. Successful implementation of systems will be communicated to stakeholders and the economic advantages (including job creation) will be determined.

### **Advanced Materials for Energy Conversion**

*(for the Assistant Secretary for Energy Efficiency and Renewable Energy [program EB] and the Assistant Secretary for Fossil Energy [programs AA, AB])*

Government and private studies have concluded that new materials will drive advances in many industrial sectors. The need for government-sponsored research and development leading to advances in materials technology has been clearly delineated. The National Energy Policy Act of 1992 mandates a five-year national advanced materials program plan.

Advanced materials will play a major role in the area of energy conversion in coming years. The need for materials with higher performance in extremes of temperature, pressure, and corrosive environments, and the need for energy savings and environmental sensitivity require major advances in structural and functional materials. Research and development in structural materials includes ceramics, intermetallics and alloys, coatings, and joining. Functional materials research and development includes the areas of catalysts, membranes, filters, insulators, and adsorbents. This initiative focuses on research and development in both structural and functional materials for energy applications.

Advanced structural materials that can operate at higher temperatures and pressures and that are more corrosion-resistant will allow the use of new higher-

efficiency energy conversion and industrial processes. However, these high-performance materials often have drawbacks, including high cost and difficulty of forming and joining parts. Proposed research and development in structural materials includes new processing methods for increasing ductility and workability of high-temperature chromium-niobium alloys, synthesis of nanometer-sized silicon nitride and carbide powders for high-temperature ceramics with enhanced sintering performance, novel joining technologies for advanced ceramic and alloy structural materials, thermal spray technology for corrosion and impact resistance, and high-temperature coatings. In each area, we are building on expertise resident at Sandia and on specific structural materials requirements in the DOE Fossil Energy and Energy Efficiency and Renewable Energy programs.

Products of catalytic processes impact almost every aspect of our lives, including our food, clothing, transportation, energy, environment, health care, and defense. Because catalytic processes account for 20 percent of the US gross domestic product, research and development leading to improvements in catalysts and catalytic processes can have a substantial positive impact on the economy.

Catalysts create a \$180 billion export market in chemicals and contribute \$12 billion toward a positive US trade balance. Catalytic research and development areas addressed in this initiative include emissions control, catalytic membrane reactors, conversion of hydrocarbon resources, and fuel cells. This effort combines established strengths at Sandia in computer-aided

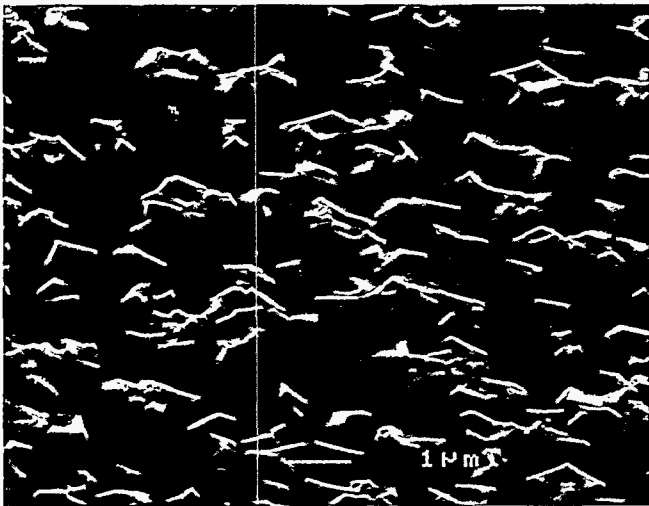

Composite membranes containing microporous (zeolite) crystals in a glass matrix promise improvements in light gas separation and catalytic technologies. These films, developed at Sandia, are thinner and more durable than similar films. Crystals shown are approximately 0.00002 inches thick.

molecular design, massively parallel computation, process chemistry and reaction engineering, materials science, and catalyst characterization and evaluation to focus on an integrated theoretical, experimental, and engineering approach to the design of advanced catalytic materials.

Porous materials are another multibillion-dollar technology that broadly impacts industrial processes. Porous materials often replace more expensive, energy-intensive processes in such energy conversion applications as the following: membranes and adsorption media for separations, ion exchange, storage, and purification; environmental and industrial process sensors; electrodes for battery and fuel cell applications; supports for catalysts; insulators; and lightweight structural materials. Porous materials research and development areas addressed in this initiative include

- corrosion- and impact-resistant high-temperature filters for gas filtration,
- unique catalytic membrane reactors,
- other micro- and meso-porous catalyst support materials,
- controlled-pore-size membranes and coatings for light gas separations,
- extremely high selectivity crystalline silicotitanate ion-exchange materials for industrial and radioactive waste,
- porous electrodes for fuel cells, and
- fast-cycle, high-capacity hydrogen and methane storage media.

This broad range of capabilities would be employed to take advanced porous materials from concept through technology transfer to industry.

### ***Solar-Dish-Stirling Systems for Utility Applications***

*(for the Assistant Secretary for Energy Efficiency and Renewable Energy [program EB])*

Modular solar-dish/engine systems can effectively address near-term, high-value utility applications such as remote generation and end-of-line capacity additions. To accelerate the introduction of this technology, several dish/engine system development and commercialization projects have been initiated. These activities are patterned after our successful remote-power dish-Stirling

joint venture with Cummins Power Generation.

These new joint ventures will develop distributed solar thermal systems of approximately 25 kilowatts per module suitable for utility markets. Like the Cummins Joint Venture, the utility-scale joint venture program will include equal cost-sharing between DOE and industry. An industrial partner capable of marketing and supporting commercialization of the technology will be required, as will participation by utilities. Significant industry direction in developing marketing plans, product development, and program planning and execution will be expected. To meet the goal of prototype system demonstrations at utility sites, large-scale demonstrations are planned to begin in three to five years.

This program could include non-Stirling cycle converters if chosen by industry. Recent technical advances and manufacturing cost reductions suggest a Brayton-cycle-based system may be economically competitive in the projected time frame of the Utility-Scale Joint Venture Program.

DOE funding for the initial phases of each of three new utility-scale joint venture programs is expected to be \$3 to \$5 million per year for about five years. Progression to the large-scale demonstration phase will require about \$5 million per year for two years for each joint venture program.

### ***Integrated Utility Systems Energy Storage***

*(for the Assistant Secretary for Energy Efficiency and Renewable Energy [program EB])*

The integrated utility systems energy storage initiative will address generation, transmission, distribution, and end-use energy storage needs. The nation's total energy use is projected to increase from 85 quads today to between 102 and 112 quads by 2010. The share of primary energy consumed to produce energy is projected to increase from 36 to 39 percent. This estimate corresponds to expanding generating capacity by as much as 245 gigawatts. During this period, to optimize baseload capacity and substation transformer loading, energy storage will become an essential capability in an integrated electrical network.

This program matches Sandia integrated systems capabilities in storage technologies (such as batteries, superconducting magnets, and capacitors) with the needs and experience of industry and DOE. Although certain energy storage technology programs are under way in the private sector and elsewhere in the federal government, there is a major role to be filled. First, to formulate long-range energy policy, a comprehensive and integrated understanding of energy storage technologies and their relative applications is required. Second, a balanced research portfolio that accelerates the incorporation of present technologies

and identifies new storage technologies should be developed. Finally, joint demonstration programs involving industry, DOE, and the national laboratories are needed to move these developing technologies to the private sector.

The successful implementation of this program will help maintain the continued growth of US industry by keeping the cost of electricity down, improving the utilization of fossil energy resources, and minimizing the environmental impact of sustained industrial growth.

### ***Wind Turbine Manufacturing***

*(for the Assistant Secretary for Energy Efficiency and Renewable Energy [program EB])*

In the past ten years, the wind power industry in the United States has progressed to more than 15,000 turbines supplying more than 1,500 megawatts of power to several utilities, primarily in California. Wind energy conversion systems must compete with conventional sources of power and produce energy in the range of four to five cents per kilowatt-hour.

A wind turbine manufacturing initiative will identify and support advanced manufacturing technologies that can foster economic growth, energy efficiency, and competitiveness in the wind industry. Breakthroughs in wind turbine manufacturing will provide the extra boost needed to make wind energy competitive with conventional power sources. Technical improvements in several areas can impact wind turbine manufacturing. They include composite design, advanced materials, structural design, systems integration, robotics, cost/performance trade-off analysis, serviceability and inspectability, and airfoil design. Application of modern concepts of agile manufacturing will improve production.

The Wind Turbine Manufacturing Project is divided into two phases. Phase one is for integrated rotor analysis and manufacturing and concentrates on ways to improve the manufacturing of rotors and blades. Phase two is for integrated system manufacturing and will seek ways to impact the manufacturing of nonrotor components and the wind turbine system as a whole.

### ***Natural Gas and Oil Technology Partnership***

*(for the Assistant Secretary for Fossil Energy [program AB, AC])*

The Natural Gas and Oil Technology Partnership is based on the successful model of the Oil Recovery Technology Partnership, which matched Sandia's capabilities with industry needs on a limited scale. This joint venture between Sandia and Los Alamos National Laboratory is cost-shared with industry and is flexible in approach; moreover, industry helps prioritize partnership

---

projects. The new Natural Gas and Oil Technology Partnership recognizes the nation's continued need for oil and gas. Oil and gas production share industry infrastructure, so it is expected that the program can benefit both.

The partnership will match Sandia's capabilities with industry's needs and experience through joint collaborative programs and will perform research and development to address the technological challenges faced by the industry. These challenges include exploration, drilling and recovery—all minimizing waste and environmental impact.

Successful implementation of the partnership will have a positive impact on the petroleum industry by providing a versatile technology base and helping to create jobs. The partnership will also maintain a leading technology base within DOE's national laboratories.

Funding will be \$10 to \$15 million per laboratory to identify the technology areas, establish industry interactions, and initiate vital projects. Funding will gradually increase during the remainder of the decade to permit the laboratories to conduct a full range of research and development identified by industry. The partnership will expand to include nine multiprogram laboratories in FY 1995.

### ***Hydrogen Storage and Utilization***

*(for the Office of Energy Efficiency and Renewable Energy [program AL])*

The environmental impacts of contemporary energy utilization and national dependence on foreign supplies are a source of continuing public concern. This concern highlights the importance of developing alternative energy sources for transportation, utility, and industrial utilization. Hydrogen is an abundant and versatile energy form that offers significant advantages over other alternative fuels, including the potential to reach zero pollutant emission levels, burn without carbon dioxide production, and be produced domestically.

There are significant challenges to hydrogen utilization, including cost-competitive energy production, efficient storage, effective conversion systems, and an infrastructure for distribution. These problems cut across several technology areas, and solving them will require the application of many disciplines. Development and demonstration of critical technologies for a hydrogen energy system is a high-risk, long-term effort well suited to a national laboratory.

Sandia is uniquely positioned to contribute to this program because we are the recognized leader in hydrogen isotope systems (developed in our nuclear weapons mission) and because our organization has multidisciplinary depth. Weapons programs will benefit from the dual-use aspects of this technology and the synergistic maintenance of our core technical expertise. The hydro-

gen energy program will be leveraged by our existing programs and facilities. Sandia's Combustion Research Facility, which has a complete spectrum of hydrogen combustion experimental and modeling capabilities, will play a central role in this program in basic and applied research.

The program will work toward an integrated demonstration of a complete storage, delivery, and conversion system. The storage element will develop alternative storage concepts aimed at maximizing energy density and engineering those concepts into storage device subsystems that can supply an internal combustion engine or fuel cell. Specific storage concepts will be high-pressure, lightweight tanks, adsorption systems, and a lightweight hydride. Other required storage system components (such as sensors, filters, and valves) will also be developed and integrated into the subsystem design.

We will focus on internal combustion engine modeling and testing, development of a hydrogen-burning conventional engine, and development of a hydrogen-burning internal combustion engine optimized for efficiency and clean emissions at a single speed and load.

In the short term, research and development will focus on fleet vehicle applications. In the long term, activities will focus on full conversion of utility systems to the use of hydrogen.

### ***Combustion Dynamics***

*(for the Office of Energy Research [program KC])*

The combustion dynamics initiative is a joint proposal by Sandia National Laboratories and the Lawrence Berkeley Laboratory in support of DOE's national role in combustion research. The initiative will improve the efficiency of combustion processes while minimizing pollutants and other undesirable effects.

The combustion dynamics initiative will require completion of the unfinished Combustion Research Facility Phase II project at Sandia and construction of the Chemical Dynamics Research Laboratory at Lawrence Berkeley Laboratory.

Research at the facilities will produce predictive combustion models using data from experimental and theoretical studies. These models could be very useful to US industry in designing next-generation combustion systems. Work at the Combustion Research Facility will develop optical diagnostics for combustion, study chemical kinetics and reacting flows, and conduct studies in chemical physics. In collaboration with researchers from universities and industry, Sandia and Lawrence Berkeley will develop and apply instrumentation for combustion studies.

These activities will result in new insights into the elementary reactions involved in hydrocarbon combustion, the structure and dynamics of highly excited molecular species, and molecular energy flow processes,

---

all of which are critical for advancing combustion technology. Results from fundamental studies of chemical reactivity and fluid mechanics will be incorporated into computer models to improve the design of engines, burners, boilers, furnaces, and gas turbines. The proposed modeling effort already has several industrial participants, including Allison Gas Turbine Company and Cummins Engine.

The combustion dynamics initiative will offer unparalleled resources for users to study fundamental and applied combustion processes. Researchers at Sandia's Combustion Research Facility will be able to utilize advanced laser systems to study ultrafast processes in chemistry and combustion and perform two- and three-dimensional imaging of the physical and chemical properties of turbulent reacting flows.

### ***Proposed Application of Nuclear Reactor Capabilities for Medical Radioisotope Production***

*(for the Office of Nuclear Energy, Isotope Production and Distribution Program [program ST])*

The US nuclear medicine industry will benefit from Sandia participation in the production of medical isotopes using our nuclear facilities and expertise in reactor engineering and associated technologies, and our expertise in sensor technology and robotics.

There are several advantages to designating Sandia as a major production source for radioisotopes for nuclear medicine. First, a US supply has been mandated by Congress because the current foreign supply has no backup, and the US radiopharmaceutical industry will benefit from the establishment of a US-based supply. Second, the DOE Office of Nuclear Energy, Isotope Production and Distribution has determined that there are no suitable commercial reactor facilities and has recommended Sandia as a DOE option. Third, Sandia provides multiprogram flexibility, reduced costs, and nuclear technology infrastructure capable of developing improved processes and optimized production facilities. In addition, extant reactor and hot cell facilities require only minor modifications to irradiate and perform postirradiation processing of fission targets, and no over-the-road transport is required between the reactor and the hot cell facility. Sandia also has substantial radioactive waste management expertise to minimize and otherwise manage the production waste stream. Finally, Sandia can be an essential supplier of radioisotopes and provide a national focal point for US research in nuclear medicine. Proposals in this area should address medical radioisotope production, processing, research, and development, as well as radio labeling for therapy, diagnosis, or imaging. Compatible initiatives include production of radioisotopes for industrial applications

such as gauging and tool wear measurement, and use of reactor neutrons for fusion reactor first-wall radiation damage studies.

Nuclear medicine has become a very important part of the health care system in the United States, and in the rest of the world. Nuclear medicine requires a reliable and continuous supply of radioisotopes such as technetium-99m, which results from the decay of molybdenum-99. Technetium-99m is involved in 85 to 90 percent of all nuclear medicine procedures in the United States, and its use is expected to increase at a rate of 10 to 15 percent a year. It is currently supplied almost exclusively by Nordion International, Inc. of Canada. The House Government Operations Committee has charged DOE to fill an urgent need for a US supply of molybdenum-99 for medical applications within two years. The Office of Nuclear Energy, Isotope Production, and Distribution has responsibility for meeting this requirement. We propose to make the nuclear facilities and associated technologies of Sandia Technical Area V available to achieve this important national goal. The molybdenum-99 would be produced in the Annular Core Research Reactor (ACRR) by the fission process, separated from other fission products, and prepared for shipment in the Hot Cell Facility.

As presently envisioned, the project involves two phases. The facilities preparation phase involves modifying the ACRR and Hot Cell facilities and meeting Food and Drug Administration and environmental safety and health regulatory requirements. The production phase includes a transition from the current ACRR fuel to a less expensive, more readily replaceable fuel. A third phase, decontamination and decommissioning, is not scheduled at this time. Other activities such as support for development of optimized production and processing, technology transfer, and transitioning to private industry will be considered. The first two years of the project are the preparation phase; the production phase follows. The cost projections for the first five years of the program are included in the following table.

Funding Requirements for Initiative Project Proposals in  
Energy Research and Technology Development  
(Dollars in Constant FY 1994 Millions; Personnel in FTEs)

	<u>Year 1</u>	<u>Year 2</u>	<u>Year 3</u>	<u>Year 4</u>	<u>Year 5</u>
Photovoltaics Industry Development Federal, State, and Regional Government Agency Photovoltaics Initiative					
Operating	3.0	4.5	6.0	6.0	5.5
Direct Personnel	4	5	7	7	6
Photovoltaic Collector Manufacturing Process Development					
Operating	2.5	3.0	4.0	4.5	5.0
Direct Personnel	6	8	9	10	11
Photovoltaic Balance-of-Systems Manufacturing Technology					
Operating	8.0	10.0	12.0	11.0	9.0
Direct Personnel	5	7	8	8	7
Photovoltaic Systems Lifetime Improvement					
Operating	3.5	4.0	5.0	4.0	3.5
Direct Personnel	5	7	8	8	7
Utility Photovoltaics					
Operating	2.0	3.0	5.0	6.0	7.0
Direct Personnel	4	5	6	6	5
<hr/>					
Subtotal, Photovoltaics Industry Development					
Operating	19.0	24.5	32.0	31.5	30.0
Direct Personnel	24	32	38	39	36
Advanced Materials for Energy Conversion					
Operating	10.0	14.0	17.0	19.0	22.0
Direct Personnel	30	40	45	50	55
Solar Dish-Stirling Systems for Utility Applications					
Operating	10.0	12.0	15.0	15.0	15.0
Direct Personnel	9	9	9	9	9
Integrated Utility Systems Energy Storage					
Operating	3.5	10.0	20.0	20.0	20.0
Construction	0.5	5.0	5.0		
Total Cost	<hr/> 4.0	<hr/> 15.0	<hr/> 25.0	<hr/> 20.0	<hr/> 20.0
Direct Personnel	10	25	50	50	50

**Funding Requirements for Initiative Project Proposals in  
Energy Research and Technology Development (Continued)**  
(Dollars in Constant FY 1994 Millions; Personnel in FTEs)

	<u>Year 1</u>	<u>Year 2</u>	<u>Year 3</u>	<u>Year 4</u>	<u>Year 5</u>
Wind Turbine Manufacturing					
Operating	1.0	4.0	5.0	5.0	2.4
Direct Personnel	2	5	7	7	10
Gas and Oil Technology Partnership					
Operating	15.0	18.0	25.0	30.0	30.0
Direct Personnel	39	47	65	78	78
Hydrogen Storage and Utilization					
Operating	2.0	2.5	3.0	3.0	3.0
Direct Personnel	5	7	10	10	10
Combustion Dynamics					
Operating	5.0	5.0	5.0	5.0	5.0
Construction	10.0	9.8			
Total Cost	15.0	14.8	5.0	5.0	5.0
Direct Personnel	25	25	25	25	25
Application of Nuclear Reactor Capabilities for Medical Radioisotope Production					
Operating	1.8	3.5	9.7	9.7	11.9
Capital Equipment	1.0	2.1	0.5	0.5	0.6
Construction	1.0	2.0			
Total Cost	3.8	7.6	10.2	10.2	12.5
Direct Personnel	11	18	20	20	27
<b>Total, Energy Research and Technology Development</b>					
Operating	67.3	105.5	156.7	188.2	209.3
Capital Equipment	1.0	2.1	0.5	0.5	0.6
Construction	11.5	16.8	5.0		
Total Cost	79.8	124.4	162.2	188.7	209.9
Direct Personnel	146	211	264	310	342

## Biomedical Systems Engineering

Health care costs in the United States are increasing rapidly. These costs are a major concern of the public and contribute to the decline in US economic competitiveness. The proper application of advanced technologies through biomedical engineering could significantly reduce some costs without compromising or rationing health care.

The national laboratories possess a wealth of engineering and scientific expertise that can be applied to this critical need. However, this expertise has not yet been used to develop technologies to help reduce health care costs. Research in biology (e.g., the human genome project) is under way at several DOE laboratories but little focused effort in the United States is directed at developing biomedical technologies that have the potential to reduce health care costs.

### Project Initiatives

#### *National Biomedical Engineering Collaboration*

*(for the Assistant Secretary for Defense Programs [program GB], the Office of Health and Environmental Research, and Advanced Research Projects Agency)*

Development of affordable technologies to drive down health care costs requires both technical innovation and a thorough understanding of the medical community's requirements. We propose to establish the National Biomedical Engineering Collaboration to lead the country's efforts in applying technology to reduce health care costs.

This collaboration would allow formation of interdisciplinary teams with members from the national laboratories, university medical schools, and industry to guide technology development. These teams, dispersed throughout the United States and connected via an information infrastructure, would identify the largest cost drivers in health care delivery, define areas where technology could impact those costs, conduct focused research and development programs, and arrange for the transfer of resultant technologies to industry. A multidisciplinary approach will combine state-of-the-art technology development by the national laboratories and industry with insight from the medical community.

The major emphasis will be on a systems engineering approach to defining the role of technology in reducing health care costs. Prior to beginning technology development, a comprehensive study will identify areas in the health care delivery system where technology can reduce costs.

Sandia has already developed several biomedical

applications that could reduce costs and improve diagnosis or treatment. For example, a set of computer algorithms developed by Sandia computer scientists to find mobile targets in combat operations has been used to interpret digitized mammograms. These algorithms have increased tumor detection rates. In collaboration with the Baylor University Medical Center and the Albuquerque Veterans Administration, Sandia is applying massively parallel computational techniques to enhance the utility of magnetic resonance imaging in diagnosis of breast cancer and brain disorders. We plan to continue dual-use improvement of target recognition algorithms to serve both military and civilian needs for image processing.

High-performance computing is also enabling great advances in the field of computational biology. In cooperation with a major pharmaceutical company, Sandia is applying massively parallel computing to unravel the interactions between DNA molecules and drug molecules. This work provides insight into drugs that might eventually cure cancer and AIDS.

One of the most promising new developments in the field of medicine is that of minimally invasive diagnostics and procedures. Sandia has already demonstrated competence in the development of noninvasive sensors. For example, a spectroscopic blood monitor has been demonstrated to measure blood glucose noninvasively, making it possible for people with diabetes to more accurately manage the disease. This technology has now been licensed for commercial development. It uses computer software originally developed with DOE Defense Programs funding for evaluating explosives in the stockpile.

DOE's Office of Health and Environmental Research is developing a strategic plan for a research program in biomedical technology. Sandia is working with them to help define this program. In addition, DOE's technology transfer initiative has defined a health care Technology Advisory Coordinating Team to form projects at the DOE Defense Programs laboratories. The biomedical technology research program has led to the formation of several biomedical cooperative research and development agreements at Sandia and other Defense Programs laboratories. These Sandia initiatives form the technical foundation for our future program.

We have participated in discussions with the National Institutes of Health, the National Institute of Standards and Technology, private health care providers, and the Veterans Administration about the need for modeling and simulating the nation's health care delivery system. Such an initiative would make it possible to evaluate the cost effectiveness of various treatment options, provide a database for research on outcomes of treatment, and help in the identification of technology development road maps that could lead to reductions in health care costs.

A new trend in medicine is toward more home health care to reduce the average length of hospital stays and to allow infirm people to remain at home while being monitored. To facilitate this trend, small, low-cost



sensors with communications capability are desirable for monitoring the state of health of outpatients, postoperative patients, and home-bound patients. Such devices are also of interest to the military for monitoring the health of troops on the battlefield. We are discussing a program in this area with the Advanced Research Projects Agency and several private companies.

Development of biologically compatible materials is an increasingly important area of medical research. Sandia's role in the nuclear weapons program has provided a strong capability in engineered materials. Applications of this capability to the field of biomedical engineering will lead to new, biologically compatible materials for implantable sensors, bone and hip replacements, and skin grafts. Specifically, microcellular foams, long used for packaging nuclear weapon components, are being evaluated for applicability in bone replacement. Adhesives for permanently repairing meniscal tears have been proposed for funding through our Laboratory-Directed Research and Development program. In addition, the combination of the bioactivity of silicate glasses with the mechanical properties of structural materials may lead to the development of more useful prosthetic devices.

### **National Medical Information and Communications System Design**

*(for the Office of Health and Environmental Research, Advanced Research Projects Agency, and the Veterans Administration)*

Many studies have shown that one of the major contributors to rapidly growing health care costs is the lack of timely, accurate information on patient records. This lack of information frequently results in redundant medical tests that add to health care costs.

In conjunction with major medical research institutions, the Advanced Research Projects Agency, the Veterans Administration, and the National Library of Medicine, Sandia is exploring the application of its capabilities in data and network surety, high-speed communication links, and high-performance computing to a program for designing a national medical information infrastructure. In addition to patient records, the system could also provide high-speed image processing capability to increase the utilization of expensive equipment such as magnetic resonance imaging instruments. Substantial cost reductions appear to be possible if such a system is developed.

**Funding Requirements for Initiative Project Proposals in Biomedical Systems Engineering**  
(Dollars in Constant FY 1994 Millions; Personnel in FTEs)

	<u>Year 1</u>	<u>Year 2</u>	<u>Year 3</u>	<u>Year 4</u>	<u>Year 5</u>
National Biomedical Engineering Collaboration Operating	10.0	25.0	50.0	100.0	100.0
Direct Personnel	50	100	200	200	200
National Medical Information and Communications System Design Operating	5.0	10.0	10.0	15.0	20.0
Direct Personnel	20	50	50	70	100
<b>Total, Biomedical Systems Engineering Operating</b>	<b>15.0</b>	<b>35.0</b>	<b>60.0</b>	<b>115.0</b>	<b>120.0</b>
<b>Direct Personnel</b>	<b>70</b>	<b>150</b>	<b>250</b>	<b>270</b>	<b>300</b>

---

## Post-Cold War Defense Imperatives

The demise of the Soviet Union has diminished the strategic threat to the United States. However, we continue to face two strategic security challenges as a nation. First, the threat posed by the continuing existence and spread of technologies of mass destruction challenges us to sustain a credible nuclear deterrent and to preserve the national capability and capacity to rebuild our forces in response to unforeseen circumstances. Second, the impact and effect of an increasingly competitive global economy challenges us to ensure that our concepts of national interest and security remain current, realistic, and sufficiently comprehensive to encompass the full range of potential threats to our national integrity.

We advance the following set of coordinated nonproliferation and other defense-related proposals that will respond aggressively to the evolving challenges facing DOE in its enduring responsibilities in defense and intelligence. Care has been taken to avoid unnecessary mission expansion. In each case, these initiatives extend established responsibilities and capabilities. Each initiative expands benefits to the nation and serves to exercise, sustain, and build upon core competencies essential to meeting programmatic requirements. Therefore, these initiatives have been developed to reap further value from existing assets and resources.

## Project Initiatives

### *Proliferation Research*

*(for the Office of Nonproliferation and National Security [programs GC and GJJ])*

Preventing or countering the proliferation of nuclear and other weapons of mass destruction has been a central policy and a difficult technology problem for decades. President Clinton reinforced this policy in a speech before the United Nations General Assembly in September 1993:

One of our most urgent priorities must be attacking the proliferation of weapons of mass destruction. . . . If we do not stem the proliferation of the world's deadliest weapons, no democracy can feel secure.

In general, approaches to dealing with the proliferation of weapons of mass destruction can be divided into programs designed to understand proliferation issues, programs designed to prevent proliferation, and programs designed to respond to proliferation. These programs are frequently subdivided into two categories: nonproliferation and counterproliferation. Sandia's conceptual scheme for coordinating its activities in this area combines nonproliferation, counterproliferation, and intelligence functions—tying them together with

information technology and grounding the programs in the strength of Sandia's technology base.

Because the principles of weapon development and production are increasingly accessible to determined governments, Sandia's proliferation studies focus on the following: improving our national capability to detect and characterize clandestine nuclear activities, including materials production, weapon engineering development, and weapon testing; improving our national capability to detect and characterize chemical weapon, biological weapon, and missile technology programs; improving our ability to counter established weapons of mass destruction programs when they become a threat to our national security. We accomplish this mission using a comprehensive systems engineering approach that relies on the strength of our research program.

### *Nonproliferation*

Since the 1960s, Sandia has developed instrumentation to verify compliance with a wide variety of treaties, including the Limited Test Ban Treaty, the Nonproliferation Treaty, the Intermediate-Range Nuclear Force Treaty, and the Strategic Arms Reduction Treaty. Our current activities include improving the sensitivity of satellite sensors to detect and locate nuclear bursts in the atmosphere and assisting Los Alamos National Laboratory to enhance the capability for detecting detonations in space. Sandia acts as the systems integrator for all of DOE's space-based systems. In addition, seismic detection and data processing systems being developed in a multiagency, multilaboratory program will provide the capability to monitor proliferation-related underground and underwater nuclear tests.

We support DOE's Office of Nonproliferation and National Security by assessing foreign weapons development and providing export control guidance. Sandia also originated a variety of containment, surveillance, material control, and accountancy systems used by the International Atomic Energy Agency for its containment, surveillance, and proliferation assessment responsibilities.

The need for better technologies to detect nuclear materials production was underscored in 1991 by the extent to which Iraq had produced weapon-grade uranium without detection. Sandia has extensive experience in nuclear radiation detection and other sensor systems and the analysis of collected data. Programs include multilaboratory efforts to evaluate advanced sensing technologies to monitor various aspects of proliferant programs for all types of weapons of mass destruction and their delivery systems. Established capabilities also exist in adversarial analysis, vulnerability analysis, and analysis of foreign systems and capabilities.

Sandia has developed promising new concepts for advanced sensors that may significantly improve our detection capability in this difficult area. Ground-based or airborne air-sampling systems and airborne or space-

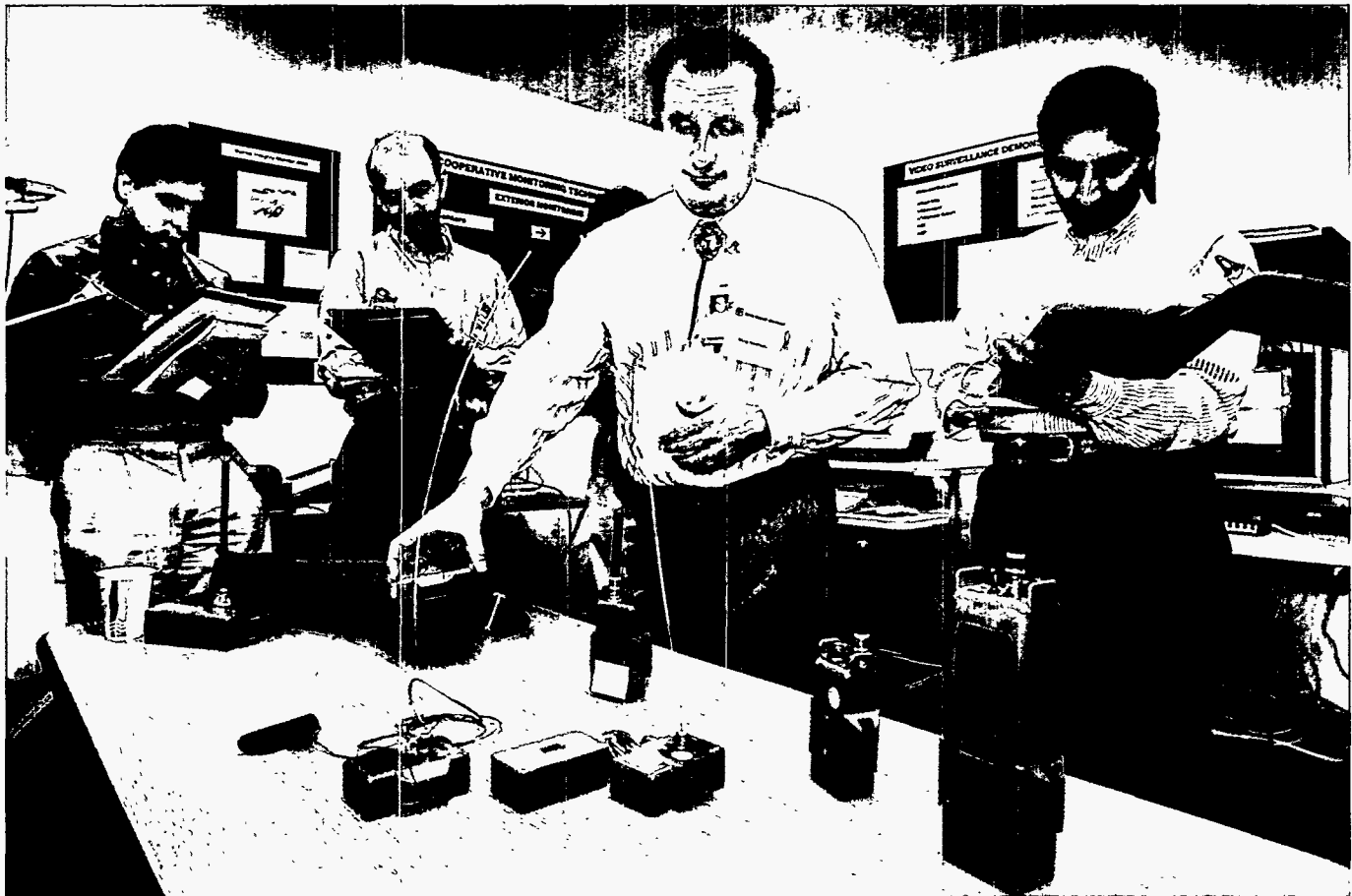

Delegates from five Middle Eastern nations inspected arms-control sensors at Sandia's Cooperative Monitoring Center. The center's purpose is to encourage cooperative monitoring in critical regions by acquainting arms control specialists, politicians and military leaders with verification and arms control technologies developed in the US.

based imaging may be effective. Advanced seismic, electromagnetic pulse, and radiometric sensors would be useful for detecting low-yield weapon tests.

Technologies for monitoring declared nuclear activities for compliance with international safeguards are also needed to increase the visibility of activities in potential proliferant nations. Confidence in such transparency measures (surveillance measures approved by the host country and using shared measurement technologies) is essential to assuring nations that have pledged not to acquire weapons of mass destruction that proliferation can and will be detected.

In addition, Sandia is focused on reducing the motivation that some nations may have to acquire weapons of mass destruction. We have initiated a program of Cooperative Regional Security designed to encourage cooperative monitoring in critical regions such as the Middle East, reducing the uncertainties that drive some nations to acquire weapons of mass destruction.

### *Counterproliferation*

The threat of weapons of mass destruction includes problems such as the following: finding mobile missile launchers; characterizing missile warheads; detecting, characterizing, and attacking underground facilities; intercepting missiles and warheads; assessing battle damage; and warning and preparing forces for imminent danger. Technological solutions to these problems can be categorized according to the key military functions of reconnaissance, surveillance, target acquisition, kill, and assessment. A systems approach will be needed to optimize, evaluate, and integrate the technologies available within this category.

The key to effective integration of these capabilities is near-real-time access to reliable, secure, focused information. This type of information is becoming more available because of advances in microelectronics, sensors, satellite communications, and computing technologies. Sandia is developing tools that will expand the classical methods

of the intelligence and military communities by adding multiple types of all-weather sensors, advanced signal processing, advanced computing and networking capabilities, real-time communications, intelligent fusion of information, and high-fidelity simulations. These data collection and analysis tools will be integrated with fast-response, precision, standoff weapons that can deliver a lethal blow with low collateral damage and with minimal risk to friendly forces. Sandia will develop these tools in partnership with government, academia, industry, and other laboratories.

Finally, Sandia offers access to unique field test facilities such as the Tonopah Test Range, the Kauai Rocket Test Facility, and the Nevada Test Site, where integrated system-level testing and validation can be performed. These test facilities can be integrated with military simulation centers such as the Air Force's Tactical Air Command and Control Facility to provide a distributed, real-time integration of test and simulation capabilities.

Sandia's robust red teaming capabilities will permit us to evaluate not only our own system designs but also those from other commercial or governmental organizations in support of comprehensive system development.

Sandia's integrated Proliferation Research Program is strengthening our national capabilities by serving as a focal point for research and expertise on the full range of proliferation-related technologies. Our broad-based, information-focused program will allow policy makers to reach time-sensitive, proliferation-related decisions knowing that they have the best available information and a full range of response capabilities.

### ***Enhanced Transportation Surety***

*(for the Office of Nonproliferation and National Security [program GD])*

Sandia has played a major role in transportation surety since the early 1970s, when the DOE transportation safeguards system was conceived and implemented. Sandia has extensive capabilities in the safe, secure transport of nuclear weapons, special nuclear material, and weapon components. Nearly every major component of the existing transportation system—including safe secure trailers, special armored tractors, and the secure communications system—was designed by Sandia. Much of the technology developed in these areas is now used in the secure transportation of high-value commercial goods.

As we enter the next century, transportation of nuclear weapons and weapon components will receive increasing public scrutiny. Although the current DOE transportation safeguards system has served the nation well over the past two decades, the increasingly dynamic international environment and the rapid rate of technological change clearly demonstrate the need to upgrade and enhance both safety and security in the transportation of nuclear weapons.

This Enhanced Transportation Surety initiative will build upon the work already being done in conjunction with the safeguards transporter exercise and will take advantage of Sandia's established capabilities. The initiative will also address other important issues and concerns that need attention.

The Enhanced Transportation Surety initiative will significantly improve overall system security and safety, reduce manpower requirements, and extend these enhancements to operational movements within the DOE nuclear weapons complex and DoD. Areas to be investigated include the following: development of improved probability risk assessment tools, consequence modeling, and accident databases; incorporation of commercially available, satellite-based mobile communications systems; and the development of satellite-based tagging and tracking. Rapid prototyping of cost-effective, application-specific solutions will be emphasized. Sandia's intimate knowledge of the current transportation safeguards system and our involvement in the complex reconfiguration task will allow system upgrades to be rapidly implemented in the field.

The enabling technologies developed through this effort will offer benefits to the private sector, including the capability for worldwide, satellite-based, real-time inventory of high-value goods in transit (of potential value to shipping industries) and enhanced dynamic modeling and simulation of accidents (of potential value to the automotive industry).

### ***Next-Generation Nuclear Weapon Controls***

*(for the Assistant Secretary for Defense Programs [program GB])*

Sandia has responsibility for both use-control features within nuclear weapons and the use-control ancillary equipment deployed worldwide, which are used by DoD to assure weapon use when authorized by the President and to assure against unauthorized use. The changing world situation has made it highly desirable to enhance use-control features in the existing nuclear weapons stockpile and in the ancillary use-control equipment systems. In addition, it would now be highly desirable to enhance the flexibility within DoD for conducting peacetime logistics operations and for dynamic operational response to future crises.

This proposal consists of five "focal efforts" that will take advantage of our established capabilities to develop vital enhancements.

#### ***Focal Effort One: Enhanced Weapon Use Denial***

After DOE, the Fail-Safe and Risk Reduction Study Advisory Committee, and the Secretary of Defense were briefed on assessments of the use-control effectiveness of weapons in the stockpile, the advisory committee recommended efforts to enhance weapon use-denial

effectiveness. Sandia, Los Alamos and Lawrence Livermore national laboratories will apply Sandia's existing materials science, explosives, and component design capabilities to enhance the current level of use-denial effectiveness. A thrust of this effort will establish approaches that can be applied to the existing stockpile as well as to future weapons. The customers for this effort are DOE and DoD.

### ***Focal Effort Two: Integrated Safety and Use Control***

Since the introduction of permissive action links (PALs), nuclear safety and use-control features within weapons have been separated. This approach was largely driven by technology available to the design community during the 1960s and 1970s. With development completed on a new code-activated PAL, the greater feasibility of optical technologies, and Sandia's capabilities in miniature mechanisms design, an opportunity exists to integrate safety and use-control functions within the weapon. Such integration will enhance nuclear safety and use-control effectiveness.

This focal effort will undertake the integration of safety and use control. The technology developed through this process could have application for upgrading the surety of existing weapons, enhancing conventional munitions safety, and providing additional command and control capabilities for both governmental and commercial applications. The customers for this effort will be DOE and DoD.

### ***Focal Effort Three: Remote Permissive Action Link and Inventory Operations***

Sandia has developed permissive action link (PAL) devices that have the capability for encrypted communications. Encrypted communication with the weapon opens the possibility of remote, secure, PAL recode and verification and weapon inventory. It offers a means of direct, secure communication with the weapon while it is in storage or being deployed. Full implementation of these capabilities depends upon the further development of a nuclear-safe means of transmitting information (eventually consisting of an electrical signal) into the weapon.

This focal effort will develop enabling technology in the form of a capability for optical transmission of energy and information to PAL devices within weapons. This optical interface will provide the required nuclear safety electrical isolation and a continuous, real-time communication link. Such a link would enable real-time communications between the weapon and the military command headquarters responsible for mission planning and execution and peacetime logistics support.

Customers for this effort will be the military services and headquarters commands. However, the enabling technologies developed in this work will also have application in inventory and control of high-value commercial goods.

### ***Focal Effort Four: Multilevel Secure Information Systems***

Sandia routinely develops secure information systems for itself and its customers and has well-established capabilities in this area. The currently accepted strategy for developing secure information systems is to isolate them from all potential threats. However, this approach has some significant disadvantages. Customers must duplicate information systems for different levels of classified data, and these systems are not flexible enough to rapidly or adequately respond to changes in requirements.

The open literature is full of challenges from government and industry to develop better ways to manage sensitive information. This proposed effort will utilize Sandia's established capabilities to develop better techniques for managing multiple levels of classified data. Meeting this challenge will exercise and sustain essential capabilities, demonstrate necessary technological leadership, and make a major contribution to the operations of both the government and the private sector, especially in this era of increasing commercial and industrial espionage.

Customers for this work include virtually all government agencies and contractors and many elements of the private sector that need to protect sensitive or proprietary information.

### ***Focal Effort Five: Use-Control Assessment***

Use-control effectiveness assessments for nuclear weapons are conducted when weapons first enter the stockpile and when changing conditions indicate that the assessments should be updated. A recent reassessment of the effectiveness of all weapons in the stockpile indicated that it would be desirable to update and refine the methodologies used in these assessments. Full-scale experiments will be required to validate these new methodologies and results of the recently completed assessments.

This focal effort will update the current use-control assessment methodology and conduct full-scale, use-control effectiveness experiments to validate the updated methodology. The results will provide information to DOE and DoD concerning the use-control effectiveness of the stockpile. Customers will be senior management in DOE and DoD.

### ***National Center for Risk Assessment***

*(for the Assistant Secretary for Defense Programs [program GB])*

Sandia has extensive responsibilities in the areas of nuclear safety and stockpile surety. Over the past few years, our efforts in these areas have expanded to include the reapplication of advanced risk assessment methods,

---

techniques, tools, and databases that have been refined through continuous improvement in our nuclear reactor safety program. The application of these techniques to weapons concerns is already providing DOE and DoD customers with unique perspectives on the surety of weapon systems.

This initiative proposes to expand these efforts to provide decision makers with a greater range of timely and technically defensible information on the risks associated with both the stockpile and other issues of importance to the nation, strengthening these capabilities through the formation of a national center for risk assessment. This center will serve as a focal point for information from the international weapons community, DOE, and the national laboratories. On a broader scale, this center will stimulate the use of modern risk assessment capabilities away from the current focus on the surety of our enduring stockpile to a wider range of dual-use applications to other advanced technology or potentially hazardous operations within the government and throughout the national strategic industrial base. Thus, the center will promote beneficial interaction among government, industry, and academia in the development and implementation of risk management methodologies.

### ***Nonnuclear Component Manufacturing***

*(for the Assistant Secretary for Defense Programs [program GB])*

DOE faces a significant challenge in reconfiguring the nuclear weapons complex from the current system of laboratories, production agencies, and supplier networks to a streamlined, more modern, and efficient system. The reconfigured complex should be capable of reducing operating costs while maintaining the readiness and credibility of the enduring stockpile and rapidly responding to unforeseen developments.

In recent years, as the pressures of international industrial competition have intensified, many of our domestic industries have faced similar challenges and have responded with innovative mixtures of new technology and modern business methods. However, most of our domestic industries are still challenged to improve their ability to deliver a product mix tailored to highly specific and rapidly evolving market requirements. This situation is made even more challenging by the fact that modern market requirements invariably include unprecedented demands for product quality and reliability at extremely competitive costs. The similarity of the challenges facing the nuclear weapons complex and our domestic industrial sector sets the stage for a new and productive partnership between DOE and the nation's strategic industrial base.

Although the existing nuclear weapons complex has met the need for a safe and reliable stockpile, the current

complex is much too large, too widely distributed, too expensive, and too outdated in relation to current requirements and modern environmental safety and health standards. DOE's strategy for consolidating and updating the complex focuses on integrating the essential competencies within the weapon laboratories and production plants with specialized new capabilities developed to meet the unique needs of the complex and the broader capabilities available within the private sector.

To be successful, DOE will need to make progress along two parallel fronts. First, progress must be made in refining and implementing advanced manufacturing processes, technologies, techniques, and materials developed within the nuclear weapons complex or adaptively reapplied to its needs. Examples include the following: computer-aided design, engineering, and manufacturing; process simulation and automation; information networks; environmentally conscious materials, design, and manufacturing; concurrent engineering; and the flexible integration of research, development, and production sites into seamless "virtual" factories.

Second, new approaches to business processes and weapon system realization will be necessary. Examples include supplier partnerships, innovative procurement strategies, and possibly a greater emphasis on standardized, commercially available components. For the most part, these are the same investments and the same new approaches that our domestic industries are exploring to build their strengths in an increasingly competitive world market.

Some of these investments and approaches have already been explored and are being developed at Sandia. Some progress has already been made in concurrent engineering, automation and robotics, electronic information networks, privatization of weapon component manufacturing and procurement, and new approaches to quality. However, much more work remains.

This nonnuclear component manufacturing initiative will build on Sandia's established capabilities, existing assets, and efforts to extend our current responsibilities to full integration of weapon system realization. This effort will involve some production responsibilities. However, most importantly, it will reflect the vision to implement a more responsive and efficient cradle-to-grave approach, from initial weapon concept through production and service life to final retirement, dismantlement, and disposal.

Successfully implemented, this effort will reach well beyond the requirements of the nuclear stockpile and will create within the nuclear weapons complex a national resource for the following: an exploration and demonstration of integrated research, development, and production operations; a test bed for the development of advanced industrial processes; a model for best industrial practices; and a vehicle for DOE contributions to

advanced manufacturing and technology transfer. Major industry participation in the nonnuclear component manufacturing initiative will minimize costs and maximize value to both DOE and the private sector.

### ***Jupiter Pulsed Power Facility***

*(for the Assistant Secretary for Defense Programs [program GB])*

The cessation of underground nuclear testing created a critical need to improve our national radiation simulation capabilities. In the past, underground testing was a major contributor to the understanding of weapon physics and phenomenology and in testing/certifying this understanding in radiation survivability of weapons, weapon systems, and their associated infrastructure. In order to maintain the competence necessary to support evolving military needs and to assure confidence in the enduring stockpile, we must expand our analytical understanding and aboveground simulation capabilities. The Jupiter Pulsed Power Facility will advance simulator capabilities and maintain critical competencies in radiation effects science, weapon physics, weapon effects experimentation and testing, and pulsed power science.

The facility will provide ultrahigh-intensity plasmas that will permit weapon physics experiments and x-ray testing of both materials and components. The facility will be built by extending Sandia's established capabilities through the application of new technologies developed at Sandia, other government laboratories, universities, and industry. The facility will have a pulsed power generator to drive a z-pinch implosion to produce plasmas with temperatures of 3 million degrees, enabling multiple types of testing. This capability will provide excellent simulation of radiation effects for testing optics, materials, and weapon components. It will also provide critical radiation environments for weapon physics experiments.

Sandia has the responsibility to ensure that the nonnuclear components of US strategic nuclear systems are safe, reliable, and capable of surviving hostile radiation environments. The Defense Nuclear Agency has the complementary responsibility of ensuring that strategic weapons and space systems are also capable of surviving similar environments. Given these parallel missions, a strategic alliance between Sandia and the Defense Nuclear Agency was made in 1991, with both organizations agreeing to work cooperatively in developing advanced pulsed power systems and radiation simulation capabilities in support of their missions.

Additionally, since cessation of nuclear testing, DOE has a requirement to maintain competencies in weapon physics and radiation effects in the event that the United States is called on in the future to provide such expertise. Pulsed power science at Sandia provides the thrust

behind the Jupiter developmental design. Ultrahigh temperature plasmas generated by Jupiter could also be instrumental in weapon physics experiments without underground tests. Such a simulator would support the DOE goal of maintenance of core competencies.

The construction of the Jupiter facility will substantially improve our capability to generate ultrahigh temperature plasmas in the laboratory. These in turn will allow advanced weapon physics studies and will substantially improve our capability to provide significant quantities of cold and warm x-rays in intense fluences over large areas. Because the Jupiter facility can meet imperative needs for both DoD and DOE radiation simulation, it is regarded as a joint effort to be equally funded by both agencies.

### ***Former Soviet Union Cooperative Measures***

*(for the Assistant Secretary for Defense Programs [program GB] and the Office of Nonproliferation and National Security [program G])*

Sandia's cooperative measures with the former Soviet Union support the US government's policies on nonproliferation, support emerging democracies, and foster defense conversion and commercialization. We also support DOE's Safe and Secure Dismantlement Working Group activities for the Nunn-Lugar and Freedom Support Act authorizations, now totaling about \$1.4 billion through FY 1995. Sandia has been actively involved in a government-to-government agreement to allow unclassified technical exchanges on nuclear warhead safety and security. We anticipate working with Russian design experts in this activity.

Sandia has been very active in the development of the two-phased newly independent states partnership, which will enable collaboration between Sandia and former Soviet Union military institutes whose stability is important to nonproliferation and will facilitate commercialization partnerships with US industries and former Soviet Union defense institutes. During the first phase, we intend to establish about forty individual projects with former Soviet Union institutes, principally in the areas of nonproliferation, reactor safety, materials, environment, energy, and manufacturing. During the second phase we will develop partnerships with US industry to foster commercialization of these projects.

Sandia expects to fully support the pending agreement between the US and Russian Governments on the technical exchange of nuclear warhead safety and security information. This involves unclassified information on topics related to nonproliferation, safety, security, and physical protection and will provide a forum for exploring important issues of mutual interest and benefit. We expect to actively support the technical working groups of this exchange.

**Funding Requirements for Project Proposals in  
Post-Cold War Defense Imperatives  
(Dollars in Constant FY 1994 Millions; Personnel in FTEs)**

	<u>Year 1</u>	<u>Year 2</u>	<u>Year 3</u>	<u>Year 4</u>	<u>Year 5</u>
<b>Proliferation Research</b>					
Operating	110.0	130.0	140.0	140.0	140.0
Capital Equipment	8.0	10.0	10.0	10.0	10.0
Total Cost	118.0	140.0	150.0	150.0	150.0
Direct Personnel	317	375	405	405	405
<b>Enhanced Transportation Surety</b>					
Operating	5.5	7.0	7.0	5.0	5.0
Capital Equipment	0.1	0.2	0.1	0.1	0.1
Total Cost	5.6	7.2	7.1	5.1	5.1
Direct Personnel	25	30	30	25	25
<b>Next-Generation Nuclear Weapon Controls</b>					
Operating	17.1	17.0	17.0	17.0	17.0
Capital Equipment	1.7	2.0	2.0	2.0	2.0
Total Cost	18.8	19.0	19.0	19.0	19.0
Direct Personnel	84	84	84	84	84
<b>National Center for Risk Assessment</b>					
Operating	11.2	15.0	18.0	20.0	20.0
Capital Equipment	1.0	0.5	1.0	1.0	1.0
Total Cost	12.2	15.5	19.0	21.0	21.0
Direct Personnel	60	75	90	100	100
<b>Nonnuclear Component Manufacturing at Sandia</b>					
Operating	50.0	75.0	100.0	125.0	150.0
Direct Personnel	135	200	265	335	400
<b>Jupiter Pulsed Power Facility</b>					
DOE Operating	10.0	8.0	4.5	2.0	2.0
DOE Construction			20.0	30.0	30.0
DOE Total Cost	10.0	8.0	24.5	32.0	32.0
Direct Personnel	5		25	25	25
DoD Total Costs	6.3	14.2	31.5	32.0	25.6
<b>Total, Post-Cold War Defense Imperatives</b>					
Operating	203.8	252.0	286.5	309.0	334.0
Capital Equipment	10.8	12.7	13.1	13.1	13.1
DoD Funding (Jupiter)	6.3	14.2	31.5	32.0	25.6
Construction			20.0	30.0	30.0
Total Cost	220.9	278.9	351.1	384.1	402.7
Direct Personnel	626	764	899	974	1,039



*Programs*

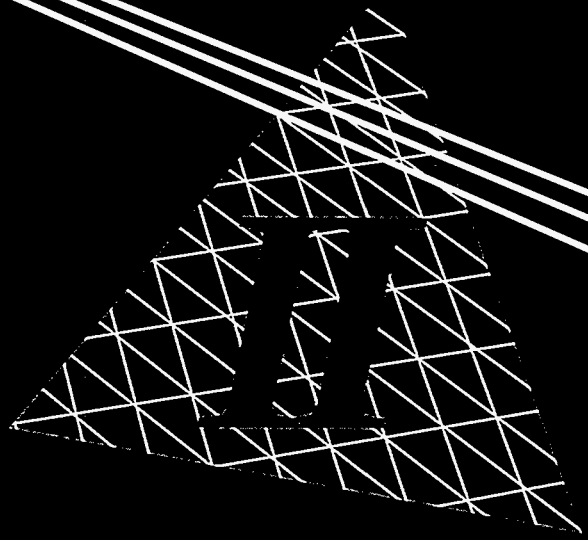

## 6 • Technology Transfer

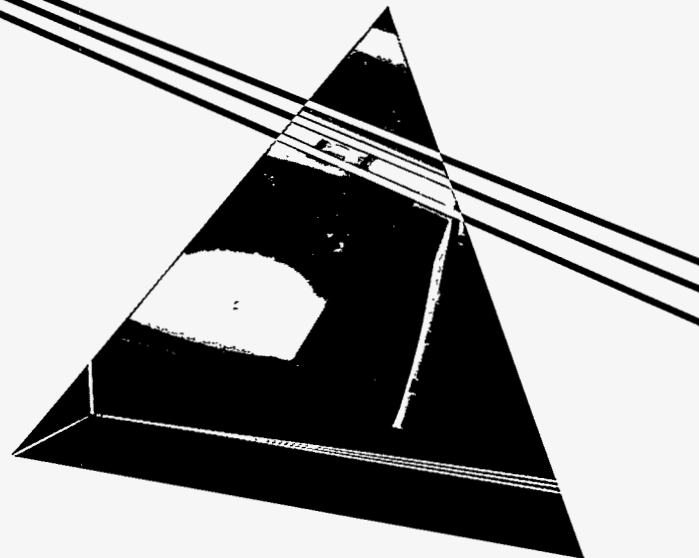

Sandia's technology transfer program transfers federally developed technologies, processes, and special technical know-how to the private sector. Closer cooperation between the public and private sectors is key to the revitalization of American competitiveness in the global marketplace. Our technology transfer program enhances US economic competitiveness by applying laboratory strengths to problems of national importance, emphasizing partnerships with industry and universities. Sandia is committed to protecting national security interests, providing fairness of opportunity to industry, creating lasting value to the taxpayer, and adhering to the highest ethical standards to avoid even the appearance of conflicts of interest.

Sandia's history of transferring technologies developed in weapons and energy programs to the civilian industrial sector predates the legislative mandate for technology transfer by more than three decades. Long before technology transfer became a mission assigned to Sandia by the National Competitiveness Technology Transfer Act of 1989, we learned that teaming with industry in technology development and transfer is a smart business practice that enhances our ability to meet our obligations.

We consider the use of our core competencies to help improve the US economy to be a natural extension of our

defense and energy missions. Government/industry/university collaboration (i.e., the mutual exchange of knowledge, skills, and facilities) enables the national laboratories to maintain the core competencies that make them important national assets. Because Sandia's core competencies are well matched with industry's needs, collaborations allow the private sector to leverage its research and development resources by taking advantage of the federal defense research and development investment. Sandia's major program initiatives (see chapter 5) strongly support this vision of technology transfer.

To help ensure that Sandia's talents and facilities effectively meet national needs, our technology transfer organizational structure has product-area managers who possess technical backgrounds and business training. Product-area managers work with program managers and technical line organizations to integrate technology transfer considerations into the planning and conduct of all laboratory research and development.

Technology transfer at Sandia takes many forms. We are engaged in a variety of technology transfer activities, including personnel exchanges, patent and copyright licensing, use of facilities, cost-shared contracts, technical assistance, information dissemination, participation in industrial consortia, and cooperative research and development agreements (CRADAs). Since 1991 (the first

year of our legislative mandate), the CRADA has become our most successful technology transfer mechanism because it gives industries whose products are not directly related to DOE programs access to laboratory capabilities.

CRADAs are distributed among six broad technical areas: advanced manufacturing and precision engineering, computer architecture and applications, energy and environment, materials and processes for manufacturing, microelectronics and photonics, and health care technologies. Technological advances from Sandia's work in microsensors, telemetry, data processing, and software and materials engineering are proving to be appropriate for application in a diversity of nondefense fields. Since our first CRADA was signed in June 1991, we have initiated more than 150 CRADAs with a total value of more than \$500 million.

Although the number of CRADAs reflects the growth of our research and development partnerships, it is not necessarily an effective measure of the success of a technology transfer program. Industry must ultimately evaluate our success or failure. Recently, we resolved to solicit more quantitative feedback from our industrial partners to help measure the contributions of our technology transfer program.

In general, our industry partners have judged the value of their association with us favorably. The feedback we have gotten will be the basis for improvements. Despite initial procedural obstacles, we are currently oversubscribed in our CRADA program by a substantial margin and have received many solicitations by industry for nonCRADA cooperative work.

## Technology Transfer Program Strategy

Our strategy for technology transfer has evolved from maximizing the number of small cooperative research and development agreements to seeking large-scale alliances with industry and universities. In the last two years, we have begun to focus on teamwork with clusters of companies and larger-scale alliances in which the capabilities of DOE laboratories, industry, and universities are combined in industry-driven, precompetitive research and development agendas.

The future holds great promise for more effective mechanisms and strategies for technology collaboration in a broad sense. We think that federal research and development investments at DOE defense laboratories will yield their full potential to improve industry's economic competitiveness while continuing to meet our national security mission only if at least three critical requirements are met:

1. The investments target major national technology goals that are market-driven, industry- defined, and precompetitive;
2. The investments lead to a high degree of collaboration among industry, universities, and federally supported laboratories, utilizing federal industrial cost-sharing arrangements to the fullest extent possible; and
3. DOE defense laboratories technology partnerships are strategically aligned with our core competencies and integrated capabilities.

Satisfying these requirements becomes more feasible as joint research and development becomes more common and the scope of industrial cooperation expands. Major industry trade associations and consortia are developing road maps (technology strategies) that outline technical and business strategies to solve major industry problems and increase their competitiveness in global markets. At the same time, the laboratories have defined technologies and capabilities critical to meeting their continuing national security mission. Therefore, the intersection of these two endeavors is becoming increasingly clear, providing opportunities for strong dual-benefit technology partnerships.

For example, the Semiconductor Industry Association recently issued a technology plan for the US microelectronics industry through the year 2013. Written by 179 US semiconductor experts from industry, government, and universities, the plan identifies opportunities for DOE multiprogram laboratories to help the industry address its generic technology needs.

In response to the microelectronics industry's stated needs, Sandia established its Center for Microelectronics Technologies to assist industry in dual-use projects. This center was created by combining the existing, DOE-funded Microelectronics Development Laboratory at Sandia with a major donation of equipment and research instrumentation from IBM valued at more than \$20 million. This centralized user facility will create partnerships with US microelectronics manufacturers and universities to develop the technologies, manufacturing equipment, and advanced processes on which the future of both commercial and defense electronics depends. The center will also train US graduate students in the most advanced integrated circuit technologies in the world.

Similarly, the US Optoelectronics Industry Development Association (OIDA) has created a technology road map to chart a course for advancing industry opportunities in the emerging optoelectronics markets. Of the five critical areas for joint research and development identified by OIDA, Sandia has technical leadership in two—optoelectronic materials and optoelectronic manufacturing processes and equipment. Sandia's Compound Semiconductor Science and Technology Center provides an ideal

facility at which cost-leveraged partnerships involving US industry, universities, and government researchers can perform the precompetitive development of the design tools, processes, and related production equipment essential to US optoelectronics manufacturers. Proposals for collaboration in research and development work with the optoelectronics industry are being considered. As envisioned, an advisory board will recommend projects that combine teams of researchers from government and industry laboratories and universities. The teams will include major industry partners who will commercialize research results.

These two industry/university/DOE laboratory collaborations clearly presage future cooperation between the public and private sectors that will revitalize the nation's high-technology industrial base and strengthen and preserve the unique capabilities that enable the national laboratories to respond quickly and efficiently to strategic uncertainties.

## Technology Transfer Thrusts

At Sandia, technology transfer presently encompasses three major elements: research and development partnerships, technology deployment, and entrepreneurial initiatives.

## Research and Development Partnerships

Cooperative research and development agreements have become our most successful mechanism for structuring collaborative work arrangements between Sandia and partners in the private sector. This mechanism is simpler than conventional government contracts, protects a company's confidential information, and permits wide latitude in the assignment of intellectual property rights.

## Cooperative Research and Development Agreements

Under the terms of a cooperative research and development agreement (CRADA), Sandia may contribute facilities, property (including intellectual property), and personnel to the cooperative effort. Sandia may also pay costs associated with the participation of its personnel or the contribution of property and facilities but may not provide cash funds to a participant. Sandia's partners in the private sector may provide funds to Sandia as well as personnel, services, facilities, equipment, or other resources needed for the proposed work. Implicit in a CRADA is the idea that the participants are equal partners who bring to the interaction

complementary, identifiable capabilities that will lead to a new or improved product or process.

Our CRADA mechanism is very inclusive. Sandia's CRADA partners include municipal governments, universities, industrial consortia, other laboratories, and large and small businesses. In addition to CRADAs with individual companies, many of our CRADA projects involve clusters of companies representing a substantial segment of a specific industry or organizations that represent an entire industry.

To date, four industrial partners are involved in a Sandia/US industry consortium to drastically reduce the time required for computer-aided design of vehicles and other industrial products. Others may join in the future. During the next three years, this Sandia-led consortium will commercialize and further develop innovative mesh-generation software developed by Sandia. Current partners are MacNeal-Schwendler Corporation, PDA Engineering, Fluid Dynamics International, and Ford Motor Company. Each industry participant will use the software to develop a commercial product or service in the area of computer-aided-engineering software or in applications for

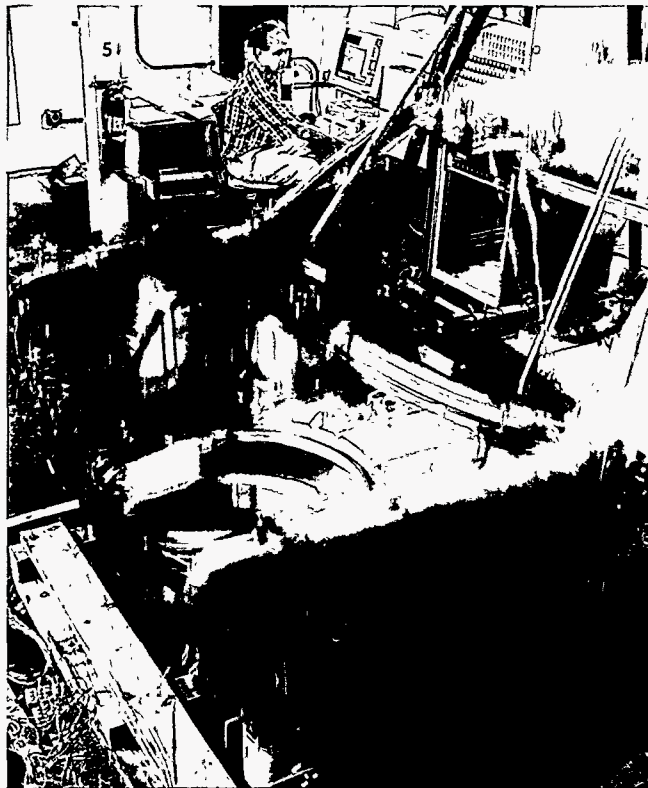

A researcher conducts an experiment on the substructure of a General Motors car as part of a project supported by a Sandia/General Motors cooperative research and development agreement (CRADA) on structural system identification.

---

finite-element analysis—a powerful numerical method for determining the physical behavior of an object that is useful in many industrial fields, including structural mechanics, electrical engineering, and fluid mechanics.

Three General Motors divisions have signed CRADAs with Sandia involving expenditures of approximately \$30 million to help provide lighter, lower-emission, more environmentally sound automobiles. A project with General Motors' Saginaw Division will improve the process of induction hardening of parts. Another project with the AC Rochester Division will develop fluid monitors for use in vehicle engines, emphasizing oil quality, coolant, and battery electrolytes. Another agreement with the Cadillac Luxury Car Division will develop an intelligent knowledge-based system for selecting materials for a new generation of cars.

Sandia is also assisting three printed-wiring board manufacturers by transferring existing technologies and by continuing research in materials, soldering, and chemical processing. Participants include three members of the National Center for Manufacturing Sciences: AT&T, Texas Instruments, and the Hamilton Standard subsidiary of United Technologies. Sandia's research with these consortium members involves processes for lamination, resin development and reinforcement, board defect prevention analysis, copper plating, solder wetting dynamics, solder flux chemistry, and development of solderability test methods.

Our CRADA with the United States Advanced Battery Consortium exemplifies our agreements with industrial consortia. The consortium is a partnership of Chrysler, Ford, General Motors, the Electric Power Research Institute, and some individual electric utilities. It was formed in 1991 to develop rechargeable battery technologies for electric vehicles.

Sandia will conduct applied research and testing to meet the consortium's objectives, which include demonstrating production capability for a battery with a five-year life that could be produced in the late 1990s and demonstrating by 1994 a battery with a ten-year life that could be produced sometime after 2000. Development of advanced batteries will help auto manufacturers meet the 1998 deadline set by several states for the introduction of electric vehicles.

Technology developed by this CRADA will be available to the consortium and its licensees. The project will enhance the competitive position of the United States in battery and automotive markets and help assure a viable and competitive domestic battery industry.

## National Industrial Alliances

Although we continue to think that much good work is accomplished through joint efforts with individual industry partners, we also think that large-scale government/industry/university alliances afford the best

opportunity for having a measurable impact on US economic competitiveness. Such alliances can target major national technology goals that are market-driven, industry-defined, and precompetitive. Such alliances are most effective when industry is strongly involved in setting priorities, developing plans, and moving technologies toward commercial application.

Sandia participates in the Alliance for Photonics Technology, a cooperative venture of Los Alamos National Laboratory, Sandia, the Air Force Phillips Laboratory, and the University of New Mexico Center for High-Technology Materials. The alliance will enhance the competitiveness of US industry in the critical technology of photonics by accelerating the transfer of federally funded photonics technology to industry. The alliance will utilize Sandia's internationally recognized research and development programs in compound semiconductor materials, physics, and devices, as well as in quantum electronics, lasers, and sensors.

Sandia's special facilities include the 3,700-square-foot Compound Semiconductor Research Laboratory clean room, extensive characterization facilities for photonics and optoelectronic devices, and severe environment test facilities.

Sandia is working with the National Center for Manufacturing Sciences in a five-year cooperative research and development agreement (CRADA). This consortium CRADA addresses precompetitive technologies needed for next-generation electrical components. The program, begun in September 1992, involves research in individual electronic devices. The CRADA will enable US companies to keep their leadership in the manufacture of printed-wiring boards for electronic devices.

Sandia is a participant in the American Textile Partnership (AMTEX), a research and development collaboration of DOE, DOE's multiprogram laboratories, universities, and the textile industry. The goal is to strengthen the competitiveness of the integrated US textile industry via a broad, industry-driven research agenda. AMTEX institutions are the Institute of Textile Technology, Textile/Clothing Technology Corporation, Textile Research Institute/Princeton, Cotton Incorporated, and the National Textile Center (a consortium of four leading textile research universities).

Sandia has signed an agreement with the Department of Commerce's National Institute of Standards and Technology (NIST) to help coordinate research and development to support the semiconductor industry's road map and to boost the competitiveness of that industry in world markets. The joint agreement covers microelectronics, advanced manufacturing, materials, and standards. The collaboration, which brings together federal and industrial researchers, will be driven by industrial needs. Initially, Sandia and NIST will concentrate on microelectronics research aimed at improving the quality of US semiconductor products. Industrial

needs in semiconductor research are well identified through a road map created by the Semiconductor Industry Association, a sixteen-year-old trade group representing all facets of semiconductor production. The two federal laboratories will also jointly conduct research into control of chip production processes and ways to assure semiconductor reliability at the time of manufacture.

Sandia has joined with other DOE laboratories and NIST to help the US machine tool industry compete in the world marketplace. The National Machine Tool Partnership, which offers free technical assistance to US companies, was developed by a laboratory group chartered by DOE Defense Programs and initially chaired by a Sandian. Los Alamos National Laboratory, Lawrence Livermore National Laboratory, and the Oak Ridge Y-12 Production Plant also were represented on the committee. The group developed a strategic plan for aiding approximately six hundred US companies that manufacture machine tools and more than three thousand US companies that provide precision machining and metalworking services. A six-month pilot effort to match resources of the DOE laboratories and NIST with industry needs will proceed in parallel with the development by DOE and NIST officials of a comprehensive strategy for a five-year program to address issues important to the machine tool industry.

A new five-year CRADA with the US semiconductor industry consortium (SEMATECH) will improve semiconductor manufacturing technologies for the next generation of integrated circuits, including equipment that reduces manufacturing costs while increasing yield. This work should help US semiconductor equipment manufacturers compete with foreign suppliers. The new CRADA builds on a relationship established with SEMATECH in 1989 when Sandia's Semiconductor Equipment Technology Center was formed. It also extends a 1992 agreement that established the Contamination-Free Manufacturing Research Center at Sandia to study ways to reduce trace levels of contamination in semiconductor manufacturing, a critical problem facing microelectronics manufacturers.

The Specialty Metals Processing Consortium has been a highly successful effort to improve the economic competitiveness of the domestic specialty metals industry. Through the consortium, Sandia is working with the small but critically important specialty metals industry to improve the technology base for melting processes used in manufacturing specialty metals. Specialty metals such as high-performance steel and titanium or nickel-based alloys are critical to US national security and economic competitiveness in areas ranging from microelectronics to airplanes.

The Specialty Metals Processing Consortium has conducted several major investigations. Most of the research has been within Sandia's Melting and Solidification Laboratory complex, which features the only large-scale, fully instrumented research furnace in the

country. Results of the industry-selected research projects are generic, so each member company can develop its own proprietary processes and products. Patents resulting from this work will be made available to consortium members through a royalty-free licensing arrangement.

Following the recent dissolution of the Soviet Union, the Specialty Metals Processing Consortium has recognized a unique opportunity to form a program for collaborating with the country of Ukraine. Through visits to Ukrainian manufacturing facilities and technical institutes, consortium members have identified unique specialty metal technologies previously unknown and unavailable to the west. The Pilot Program for US/Ukraine Technical Collaborations has been formed to acquire these technologies and demonstrate that benefits can be immediately derived by both sides as a result of the collaboration.

Sandia is participating in National Laboratory Stabilization Partnerships with the newly independent states of the former Soviet Union. The 1994 Foreign Operations Appropriations Act establishes a DOE program involving US industry and academia, DOE national laboratories, and former Soviet states to achieve nonproliferation, stabilize key former Soviet weapons institutes, promote US competitiveness, and encourage enterprise development in the former Soviet states. Major thrusts of the program are to stabilize the technology infrastructure of the former Soviet Union state institutes through expansion of laboratory-to-institute projects and to initiate cost-shared projects among US industry, the national laboratories, and former Soviet Union state institutes to identify and apply former Soviet Union technologies of commercial value.

## User Facilities and Laboratory Centers

The laboratory centers and facilities discussed below are focal points for coordinating research and development of applied technologies. The Combustion Research Facility, the Electronics Quality Reliability Center, and the National Solar Thermal Test Facility are designated DOE user facilities that are important vehicles for collaboration with the private sector.

All the centers and facilities are vital mechanisms for technology transfer and are available to industrial partners to ensure that US industry gets maximum benefit from technologies and capabilities developed at Sandia. The research and technology development activities conducted in these facilities satisfy a broad spectrum of dual-use needs for government and industry.

### *Advanced Manufacturing Processes Laboratory*

This laboratory, a center for advanced prototype manufacturing housed in a 100,000-square-foot facility at Sandia's New Mexico site, features hybrid microcircuits, thin films, printed circuits, ceramics, plastics, and rapid

---

prototyping capabilities. The laboratory coordinates its activities with the Integrated Manufacturing Technologies Laboratory at Sandia's California site. The laboratory focuses on reliability and quality through understanding and qualification of manufacturing processes. This facility is also a proving ground for custom sensors for manufacturing processes.

### ***Advanced Materials Laboratory***

The Advanced Materials Laboratory is a joint government/university/industry facility. The laboratory promotes joint research among Sandia, Los Alamos National Laboratory, the University of New Mexico, and US companies in materials and process research, development, and application, and aids in transferring the resulting technologies to industry.

### ***Aging Aircraft Nondestructive Inspection and Validation Center***

This center encourages the development of nondestructive techniques applicable to aircraft structural inspection, validates this technology by assessing its reliability and cost-effectiveness, and provides an interface between the inspection portion of the Federal Aviation Agency's National Aging Aircraft Program and the civil aviation industry.

The center occupies 27,000 square feet of hangar space at Albuquerque International Airport and includes 125,000 square feet of pad space. It is supported by a staff of eleven people and operates on a budget of approximately \$3 million per year from the Federal Aviation Agency.

### ***Center for Contamination-Free Manufacturing***

This center was formalized by a cooperative research and development agreement between the US semiconductor industry consortium SEMATECH and Sandia in 1992. The center exploits the unique layout of Sandia's Microelectronics Development Laboratory to verify advanced semiconductor manufacturing concepts and equipment that can reduce contamination, which limits the yield of integrated-circuit manufacturing processes.

### ***Center for Liquid-Metal Processing Technology***

This center uses industrial-scale processing equipment to improve liquid-metal processing techniques and associated control methodologies. Current industrial collaborations include work on vacuum arc remelting, electroslag remelting, electron beam melting, investment casting, and thermal spray processing (plasma spray, flame spray, and wire arc spray). Interdisciplinary research is in progress to define process physics, advance equipment technology, provide industrial process monitoring capabilities, develop robust multivariant control methodologies, and establish agile manufacturing

capabilities, including rapid prototyping.

The center occupies more than 12,000 square feet of space and is supported by a staff of approximately twenty-five people, not including several University of New Mexico students. This facility will be a key element in the formation of two industrial consortia, one in investment casting and another in refractory metals.

### ***Center for Microelectronics Technologies***

The capabilities of this center are accessed by industry through a five-year, \$100 million cooperative research and development agreement (CRADA) with the US semiconductor industry consortium SEMATECH, as well as through CRADAs with individual companies. Center activities are in conjunction with the Semiconductor Equipment Technology Center and the Contamination-Free Manufacturing Research Center. The Center for Microelectronics Technologies conducts projection x-ray lithography and projection electron-beam lithography programs jointly with industrial partners to develop the next generations of processes and processing equipment. The center is the site for developing environmentally conscious procedures for semiconductor manufacturing.

### ***Combustion Research Facility***

The Combustion Research Facility, opened in 1980 at Sandia's California site, is an excellent example of Sandia's commitment to partnerships with industry and universities. This designated DOE user facility is chartered to conduct a broad range of fundamental and applied research and development emphasizing combustion science and technology. Research is conducted in collaboration with visiting scientists and engineers from industry, academia, and federal laboratories. Advanced experimental techniques, emphasizing laser-based diagnostics and advanced computational models, are used in projects that enhance our ability to burn fuels cleanly and efficiently. The Combustion Research Facility's special capabilities are also used in such areas as environmental remote sensing, waste processing, and materials processing. Novel sensors and computational models from the programs are in active use in major US industries.

This 50,000-square-foot user facility is supported by a staff of approximately seventy people. The Combustion Research Facility operates on a budget of approximately \$20 million per year, with principal support coming from the DOE Office of Energy Research and Office of Energy Efficiency and Renewable Energy.

### ***Compound Semiconductor Research Laboratory***

This facility encompasses the full range of activities required to develop the next generation of compound semiconductor electronic and optoelectronic devices. Facilities include extensive molecular beam epitaxy and

metal-organic, chemical-vapor-deposition crystal-growth capabilities, ion implantation, and e-beam lithography in a 6,000-square-foot, Class-100 clean room with state-of-the-art processing equipment.

### ***Environmentally Conscious Process Center***

This center develops cost-effective processes for reducing wastes and improving energy efficiency in manufacturing processes. It promotes the idea that designers, process engineers, and materials engineers must be included in a cradle-to-grave, totally integrated systems approach to all phases of advanced manufacturing.

Center activity is focused on the following: life-cycle analysis; solvent and chemical substitutes; soldering (including lead-free solders); cleaning technologies; electroplating and surface finishing; sensors for environmental monitoring, reliability and cost/benefit/risk analysis; alternative polymers and foams; vendor compliance; small-business outreach; and dismantlement, recycling, and reuse. Industrial sectors of particular interest include automobiles, electronics, chemicals, and textiles.

The center's future is in three key areas: creating a user facility to demonstrate improved life-cycle environmental designs; prototyping a demonstration facility for the integrated design and production of "green" printed wiring boards; and developing an education, training, and industry outreach program for environmentally conscious manufacturing processes.

### ***Integrated Manufacturing Technologies Laboratories***

These laboratories comprise an interdisciplinary mix of equipment and personnel to develop and integrate technologies for advanced manufacturing. Activities include materials and process research and development, process simulation, engineering design, and manufacturing technology support. Within the 90,000-square-foot facility, significant space is dedicated to prototype fabrication research and a demonstration area for agile manufacturing. These laboratories have a staff of eighty people and an annual budget of approximately \$7 million.

During the start-up phase, the focus has been on projection x-ray lithography, welding, precision machining, metrology, and composites fabrication. These activities will be supported by high-speed fiber-optic communications and on-line monitoring and control systems. Flagship programs include SMARTWELD (an integration of modeling, simulation, and sensors with actual welding processes to allow fabrication of critical components without extensive development time and costs) and soft x-ray projection lithography, where a laboratory-based machine will be scaled-up to demonstrate integrated circuit fabrication at submicron line widths.

### ***Intelligent Systems and Robotics Center***

This facility is a fully integrated research-to-development-to-application center that provides technologies for intelligent and agile manufacturing. Specific areas include design for manufacturing and assembly, work environment design, systems engineering and integration, process modeling and simulation, precision machining, joining, assembly, automated inspection, integration frameworks, software engineering, artificial intelligence, expert systems, robotics, machine/cell/process control, and sensors/sensor fusion. The center is the focal point for Sandia's work in information-driven manufacturing and has more than forty laboratories available for collaborative research and development.

The center occupies more than 27,000 square feet of space and is operated by a staff of one hundred employees. The robotics center operates on a budget of approximately \$31 million per year with primary support from DOE Defense Programs and the Office of Environmental Restoration and Waste Management.

### ***Microelectronics Development Laboratory***

The 74,000-square-foot Microelectronics Development Laboratory includes 30,000 square feet of clean-room space with 12,500 square feet of class-1 clean space in twenty-two separate clean rooms. The laboratory's design provides maximum flexibility for new processing equipment and device technologies and is uniquely configurable to support the joint Center for Contamination-Free Manufacturing. A major donation of equipment and technology by IBM provided a state-of-the-art, submicrometer, silicon integrated-circuit research and development line. The laboratory's complete equipment set supports the total semiconductor development cycle, including research, design, fabrication, testing, prototype delivery, qualification, and technology transfer.

Four bays of the laboratory will be dedicated to activities of the multichip module foundry consortium and will be used as an equipment applications laboratory. This unit will be an industry-shared site with all next-generation manufacturing equipment and will offer manufacturers, material suppliers, and equipment vendors an efficient way to perfect equipment, materials, and processes.

### ***National Center for Advanced Information Components Manufacturing***

In 1993 the Advanced Research Projects Agency began sponsoring the National Center for Advanced Information Components Manufacturing at Sandia to provide a resource for integrating federal and commercial research and development of advanced information components. This integration will allow the United States to greatly compress the time to translate research and development into commercial and defense products. Los Alamos and Lawrence Livermore national laboratories will also



support the center, along with representatives from industries and universities.

The center will allow industry and government researchers to exploit a range of competencies in microelectronics and photonics, electronics systems packaging, materials science and processes, printed-circuit fabrication, and other product development tools.

Research will concentrate on agile manufacturing technologies associated with advanced silicon integrated circuits, high-speed optoelectronic communications, and electronic systems and subsystems. Research in large, flat-panel displays will benefit from the consolidation of supporting technologies at a single site. Manufacturing research will focus on developing agile manufacturing processes for flat-panel products for both defense and industry.

### ***National Center for Advanced Manufacturing Technology***

This center was established at Sandia in 1991 to maximize the value of Sandia's technology base to the manufacturing needs of both the DOE nuclear weapons complex and industry. The center helps transfer and apply advanced manufacturing technologies developed in Sandia's defense programs to commercial manufacturing, thus strengthening US industry's competitiveness. The center serves as a gateway allowing private industry, academia, and government agencies access to Sandia's technical capabilities.

Because the term manufacturing is very broad, the National Center for Advanced Manufacturing Technology is an umbrella center to several of the supporting centers and user facilities described in this section. The center's activities are coordinated by a seven-person staff, and it operates on an annual budget of approximately \$1.5 million.

### ***National Center for Ultra-Reliability Engineering***

The National Center for Ultra-Reliability Engineering (NCURE) seeks a US competitive advantage in high-value products and systems through technology that makes it possible to achieve high quality. Activities include research and development on causes of device failure, advanced approaches to reliability assurance, and multidisciplinary test and evaluation capabilities. The center will support a reliability SWAT team. A particular emphasis of NCURE is assuring high reliability in small-lot agile manufacturing. The NCURE program has a dedicated staff of three people with approximately one hundred people working on various aspects of reliability technology.

### ***National Solar Thermal Test Facility***

Constructed in 1977, this designated DOE user facility enables industry and government to conduct tests requiring intense heat and to collect light with large-scale optics. Specific high-thermal flux applications include

investigating the thermophysical properties of materials and testing various solar applications. Large-scale optics can be used for astronomical observations and atmospheric sounding with a light detecting and ranging system. Testing supports several joint ventures involving DOE, Sandia, and industry, as well as reimbursable programs for customers such as the US Navy, Air Force, and Defense Nuclear Agency.

Test areas include a field of 222 computer-controlled heliostats that reflect concentrated solar energy onto a 200-foot-high tower, two 36-foot-diameter parabolic dishes, two solar furnaces, and a series of line-focus parabolic troughs that track the sun in one axis to concentrate solar power in a line.

Thirteen Sandians and twelve contractors support the operations of the National Solar Thermal Test Facility. The facility is unique in being open to the general public for tours. Several thousand people visit each year, including school groups, groups from technical conferences, and individuals.

### ***Semiconductor Equipment Technology Center***

The Semiconductor Equipment Technology Center (SETEC) was established in 1989 to support the US semiconductor industry consortium SEMATECH in improving the competitive position of the US semiconductor industry. The program has three goals: improving equipment reliability; developing diagnostic techniques for monitoring processes and adapting these techniques to improved process control; and developing models for describing and optimizing manufacturing equipment design and processes. SETEC operations are supported by a staff of approximately thirty-five persons and a cooperative research and development agreement with SEMATECH.

SETEC is improving a number of areas critical to ensuring that the US microelectronics industry will have the reliable, high-quality equipment it needs to remain competitive in global markets. The center's operations are expected to expand into other areas including semiconductor equipment design, semiconductor equipment characterization and improvement, and semiconductor manufacturing control and diagnostic sensor technologies.

## **Technology Deployment**

Sandia's strategy for the future also includes enhancing the accessibility and flow of technology to companies. This includes licensing DOE-developed technologies to enterprises willing to assume the financial risks of product commercialization, technical assistance to small businesses, and operation of user facilities.

---

## Intellectual Property Development and Licensing

Sandia averages about thirty patent applications per year. However, many invention disclosures filed by Sandia as a result of its work for DOE have not been patented or licensed for use by industry.

To encourage a higher level of licensing, an action team including researchers, the patents and legal organization, and the technology transfer center is establishing a process for making Sandia's intellectual property assets more readily available to industry. The process will include reviews of invention disclosures to identify good candidates for patenting and licensing. These candidates will then be broadly advertised, and workshops will be held to select the most qualified contenders to compete for specific licenses and ultimately to enter into licensing negotiations.

Sandia has also expanded its licensing program to facilitate the transfer of technologies through a variety of licensing options. Through commercial licenses (exclusive or nonexclusive, as appropriate), private companies can obtain the right to manufacture and sell technologies patented by Sandia in exchange for license fees and royalties.

To promote the effective use of our technologies in as many ways as possible, we try to license a given technology nonexclusively or exclusively to different users for specific fields of use. Nonexclusive licenses can sometimes ensure rapid and effective transfer of the technology to commercial or scientific uses, but we also recognize that a license may at times require various kinds of protection, including exclusivity, to protect a firm considering a large investment in a new technology. Our aim is to remain flexible and take into account the unique circumstances of each technology and licensee.

## Small-Business Technology Transfer Programs

In conjunction with Lawrence Livermore, Los Alamos, and Y-12 at Oak Ridge, Sandia established a Small-Business Technology Transfer Program. This program is a follow-on to our successful National Small-Business Technology Exchange Program. The Small-Business Technology Transfer Program will make Sandia's resources available to small businesses (500 persons or fewer). We work with small-business development centers, cooperative extension services, chambers of commerce, state economic development agencies, and vocational education institutions to identify technology partners. Included in the program are regional, short-term technical assistance programs in New Mexico, California, Arizona, Texas, and the Midwest. Also included are partnerships with industry associations to reach a greater

number of small-business clients by addressing common problems and opportunities and matching Sandia capabilities with the needs of small businesses.

We are creating new programs to make the environmentally conscious manufacturing technology developed at Sandia available to small and medium-sized businesses. An example is a proposed joint DOE/Environmental Protection Agency/Department of Commerce environmental extension enabling program in which Sandia will work with extension entities of the National Institute of Standards and Technology (NIST) to identify small business needs. We will help develop and commercialize technologies and facilitate technology deployment by training and providing advisors for NIST, state extension agents, and small businesses. We will focus on developing an on-line knowledge base for environmentally conscious manufacturing information and an electronic information-on-demand network via a teaching factory at Sandia with tools for retraining practicing engineers. We hope to increase the effectiveness of information dissemination through an extensive outreach program that will include a speakers bureau, videotapes, joint activities with industry trade groups, workshops, exhibitions, and a widely distributed "Environmentally Conscious Manufacturing Newsletter."

The Technology Information Environment for Industry (TIE-In) is being developed at Sandia. The two primary goals of TIE-In are to increase the leverage of DOE technology transfer efforts with a system that can reach hundreds of thousands of small and medium-sized businesses and to reduce the investment required by industry to utilize national laboratory technologies.

TIE-In will be supported by a user facility that operates an electronic extension service to allow users at remote locations to obtain solutions to problems. These users would not require a high level of specialized technical expertise nor would they incur the very large expenses associated with employing specialized analysts, maintaining software libraries and a software maintenance staff, developing custom databases, and purchasing and operating high-performance computing and experimental equipment.

## Entrepreneurial Initiatives

The effectiveness of Sandia's technology transfer efforts will soon be enhanced by a program introduced by the Martin Marietta Corporation. Technology Venture Corporation, a not-for-profit private subsidiary of Martin Marietta Corporation, was incorporated in September 1993 to foster the commercialization of laboratory and university technologies through private entrepreneurial activity. Technology Venture Corporation is intended to attract private investment dollars and entrepreneurs willing to assume the risk and responsibilities of commercializing technologies developed with tax dollars. In

consideration of that risk, appropriate protection will be provided by technology licensing arrangements. Sandia will work on a nonexclusive basis with Technology Venture Corporation to identify technology opportunities for possible new businesses. Technology Venture Corporation will then package these technologies and formulate business plans to attract investors to New Mexico.

## Technology Transfer Achievements

The following list is a sampler of just a few of Sandia's recent achievements in technology transfer.

- The Sandia-led consortium involving MacNeal-Schwendler Corporation, PDA Engineering, Fluid Dynamics International, and Ford Motor Company has made progress toward drastically reducing the time required for computer-aided design of vehicles and other industrial products through the commercialization and further development of Sandia's mesh-generation software. Paul Shank, manager of the Computer-Aided-Design/Computer-Aided Manufacturing Department of Ford Motor Company, stated that this software reduced modeling time from 36 hours to half an hour.
- In 1992 Hewlett-Packard (a major manufacturer of scientific and medical instrumentation, computers, and printers) signed a cooperative research and development agreement (CRADA) with Sandia's Electronics Quality/Reliability Center. This partnership will develop a product called Sandia wafer-level software for reliable devices (SWORD), a software program designed for assessing integrated circuits. Just six months after the Hewlett-Packard CRADA began, SWORD became a commercial product. Since then, five major electronic companies have purchased the testing software from Hewlett-Packard: Intel, AT&T, Advanced Micro Devices, Allied-Signal, Zilog, and Lattice Semiconductor. In addition, Hewlett-Packard has sold \$800 thousand in test systems based on the availability of SWORD.
- Military acceptance of a soldering method tested by Sandia and Motorola could significantly reduce the nation's use of ozone-damaging chemicals. In a 1992 CRADA, Sandia and Motorola demonstrated that a low-residue soldering process could be effectively used to manufacture electronic-circuit boards. Twenty to 24 percent of chlorofluorocarbon (CFC) solvent use in the United States is associated

with the cleaning of such boards. The low-residue soldering process could replace traditional methods mandated by the military that require the use of ozone-damaging CFCs. A nineteen-member task force with representatives from ten industries and the US Navy, Army, and Air Force is developing a test program to promote adoption by the military.

- Researchers at Sandia and the University of New Mexico School of Medicine have patented a sensor that measures blood glucose without drawing a blood sample. By providing an accurate, painless method for measuring serum glucose, the technology could greatly improve the quality of life for people with diabetes and reduce the incidence of complications from the disease. A recent study by the National Institute of Diabetes and Digestive and Kidney Diseases showed that a program of controlling blood sugar to near normal levels through frequent monitoring can dramatically reduce the risk of developing eye disease and kidney disease and incurring nerve damage. Tests of Sandia/University of New Mexico prototypes verified that the device consistently predicts glucose concentrations as well as hospital procedures and much better than the home glucometers used by most diabetics. The technology has been licensed to the University of New Mexico, which is in the process of finding partners to manufacture a commercial version.
- Sandia and Hewlett-Packard have developed improved process monitoring, active control, and feedback systems for fabricating advanced optoelectronic devices. Improved epitaxial materials and processes yield higher reliability compound semiconductors, transistors, and optoelectronic devices for commercial and defense applications. This laboratory/industry partnership helps maintain state-of-the-art device fabrication capabilities in a period of reduced weapon manufacturing. Through this partnership, the critical device prototyping capabilities of Sandia are maintained and enhanced.
- Sandia and SCB Incorporated, a small New Mexico business, have developed a very safe and economical semiconductor bridge initiator for civilian and military explosives applications. These devices have enhanced electrostatic discharge and no-fire safety and operate at much lower energies than is possible with contemporary hot-wire technology. The device will eliminate the need for weapon components made with known or suspected carcinogenic compounds. It could also be incorporated in automobile airbags for application in multibag systems having stringent safety requirements that cannot be satisfied with available technology.

- SI Logic, one of DOE's largest suppliers of integrated circuits and a leading supplier to the commercial electronics market, is using an induced voltage alteration technique developed at Sandia to locate failure sites in defective integrated circuits as they are fabricated. This technique can locate failures in an hour or less, a considerable improvement over the two weeks normally required when using an electron microscope. As a result, SI Logic has improved the efficiency of its fabrication and has eliminated a six-month backlog in its failure analysis. In a related effort, Signetics and Sandia needed to identify, characterize, and control the same failure mechanisms. Improvements such as these helped the US microelectronics industry surpass foreign competition for the first time in a decade.
- Sandia and BIOSYM Technologies, Inc. worked together to develop computer software that helps design polymer alloys. Polymer alloys are leading candidates to meet the need for high-strength, lightweight, inexpensive, environmentally acceptable materials. This new software, called PRISM, has been licensed by BIOSYM to a recently formed consortium of polymer manufacturers. The molecular modeling capabilities resulting from this project should be of great utility to the US polymer industry because polymer alloying is less expensive and more versatile than synthesizing and developing entirely new polymers. The information gained from this program will aid the development of high-performance polymer blends and copolymers for various weapon applications. New materials that could result include high-strength encapsulants for packaging electronic subsystems in nuclear weapons, lightweight structural supports for nuclear weapons, and new optical materials for nuclear safety.
- Sandia and Martek Lasers, Inc. developed a high-powered continuous-wave laser welding system. The company was recently purchased by Hobart Brothers Company, one of the top US manufacturers of welding equipment. This state-of-the-art system helps the United States retain its position in the high-technology laser welding market. These laser

welding systems are now fully commercialized and used by organizations such as the US Navy and major automobile manufacturers. Weapon systems use a diverse range of materials in challenging geometries, and precision welding and joining are critical processes. Improved laser welding technology helps the weapons program fulfill these demanding requirements.

- Sandia and SEMATECH have been working together since 1989 on several programs to enhance the performance of precision microelectronics fabrication equipment, improve and assure the quality of microelectronics components, and explore advanced chemical processes for producing complex integrated circuits in an environmentally responsible way. A reliability training program derived from quality assurance techniques developed for nuclear weapons has been developed for the SEMATECH member companies. Sandia has also modified weapon design and analysis technologies to improve integrated circuit fabrication processes. Through this partnership, DOE Defense Programs and the microelectronics industry both obtain improved microelectronics fabrication processes. The partnership has proved so successful that SEMATECH and Sandia have announced another five-year, \$100 million partnership to jointly develop equipment for the next generation of computer chips.
- Sandia is working with J. W. Harley, a small business in Ohio, to commercialize a Sandia fiber-optic hydrogen sensor to monitor nuclear facilities. The sensor provides a warning when hydrogen gas builds up inside electrical transformers. Use of the sensor in large power transformers can prevent explosions that could cost millions of dollars and result in loss of life. This hydrogen sensor has global commercial market potential. DOE Defense Programs will have a reliable, affordable commercial source for sensors to improve worker safety in nuclear facilities. Similar sensors may be used for such applications as monitoring the cleanup of weapons facilities.



## 7 • *Research and Technology Development Programs*

Three quarters of Sandia's operating budget is for programs for the DOE. The remainder is reimbursable funding provided by other federal agencies, principally DoD, for work in national security and other national-need programs.

### **Programs for the Department of Energy**

#### **Weapons and Waste Cleanup Programs**

Although dramatic changes in the world have significantly reduced the threat of global nuclear conflict, nuclear deterrence will remain a vital part of the US defense strategy so long as technologies of mass destruction pose a threat to our national interests. The urgency of the Cold War has passed; however, Sandia's atomic energy defense programs must remain viable for future challenges.

Our nation must remain able to face an uncertain and possibly hostile world with the confidence that comes from a safe and reliable nuclear deterrent under the assured control of appropriate national authorities. Our allies may perceive less need to acquire nuclear weapons because the United States will retain its nuclear weapon capabilities. Sandia's responsibilities for the long-term surety (safety, use-control, and security) and reliability of the deterrent are made more difficult by several new challenges, including the lack of new weapons in development, the dramatic restructuring of the nuclear weapons complex, increased stockpile weapon lifetimes, and the cessation of nuclear testing.

Weapons being retired from the stockpile in response to changes in national security requirements are being dismantled safely, securely, efficiently, and with sensitivity to public concerns about risk, security, and environmental protection. Both near- and long-term issues associated with the configuration, storage, and final disposition of nuclear-weapons-capable materials must be addressed. It remains essential to ensure sufficient security and emergency response capabilities for the substantially increased movement of weapons and materials resulting from the stockpile drawdown.

Because of the reduction in nuclear weapons production, the nation's fiscal realities, and the greater emphasis

---

on environmental safety and health (ES&H), the nuclear weapons production complex is being dramatically downsized, modernized, and reduced in cost of operation. This must be accomplished while retaining a capacity to design and build replacements for current weapon components as those components reach the ends of their service lives. Also, the capability must be preserved to design and produce new nuclear weapons in response to unforeseen world events.

To meet our ES&H responsibilities, many sites within the nuclear weapons complex are undergoing environmental stabilization and restoration. Ongoing operations within the complex are being improved from the standpoints of worker safety and waste minimization.

Possible proliferation activities anywhere in the world must be reliably detected, accurately characterized, and constantly monitored, regardless of the strategies, tactics, or technologies employed to conceal them. The means to accomplish this task must be developed, refined, consistently updated, and fully implemented. Successfully monitoring and controlling nuclear proliferation will be a vital element of preserving peace in the new multipolar world.

Reducing the nuclear danger associated with the substantial arsenal that remains in states of the former Soviet Union has become a priority. The Russian arsenal must be dismantled to the point stipulated in arms control agreements and its nuclear materials must be accounted for and secured. In addition, we must help the Russian nuclear weapon centers and scientists use their expertise in civilian activities.

With the exception of environmental restoration and nuclear waste management programs, all of these challenges are the direct responsibility of Sandia's defense programs sector. Since the end of the Cold War, the challenges facing the defense programs sector have actually grown. In recognition of the continuing threat posed by the existence and spread of military technologies, the sector must continue to ensure the safety and credibility of the nuclear deterrent.

However, the sector is also responding to the much broader range of potential challenges to our national interests, security, and vitality that results from an increasingly competitive global economy. Thus, we will continue to meet critical responsibilities in the areas of nuclear deterrence, arms control, nonproliferation, and associated intelligence while further integrating with our nation's strategic industrial base and enhancing our contributions to the economic well-being of the nation.

Sandia's defense programs sector is addressing these responsibilities in accordance with the guidance provided by the DOE National Security Strategic Plan. The sector intends to implement the priority objective within each of the five focus areas defined in the plan (consistent with available resources) while attending to the additional objectives, strategies, and performance measures.

1. The first focus area, stewardship of US nuclear weapons to maintain credible nuclear deterrence, remains a fundamental element of US national security policy. This deterrence will continue to be based upon an enduring nuclear weapons stockpile and the stewardship of that stockpile, which has been a fundamental Sandia mission for more than forty years. The foundation of this stewardship is monitoring the stockpile to ensure that the credibility of the deterrent remains high. Effective stockpile stewardship fundamentally rests on the competence of Sandia staff to identify and mitigate stockpile concerns. The sector must address the lack of new weapons in development, restructuring within the weapons complex, increased stockpile weapon lifetimes, and cessation of nuclear testing by implementing effective strategies for maintaining staff competence. Sandia's defense programs sector has fundamental responsibilities in all phases of the stockpile surveillance and maintenance process. Increased stockpile surveillance will be essential as the nation's nuclear deterrent becomes dependent on a smaller number of systems. Budget concerns and troop strength reductions, coupled with changes in priorities at the end of the Cold War, are making many of the stockpile maintenance responsibilities increasingly burdensome for the military services. The defense programs sector's critical responsibilities in these areas demand that it be prepared to monitor these trends and assist the military services whenever necessary. An example of this assistance would be greater participation in the process of limited-life component exchange.
2. The second focus area is strategic surety in all environments. The ability to maintain this confidence is of strategic importance to the nation and a differentiating strength for Sandia. Strategic surety develops and promulgates the underlying science, technologies, methodologies, prototypical components, and system architecture for nuclear weapons.
3. The third focus area is Sandia's technology infrastructure and core competencies, which reside in our physical and intellectual capabilities and are essential for the long-term viability of defense sector activities. Elements of Sandia's technology infrastructure underlie and support multiple DOE national security activities, provide the basis for productive interactions with US industry, and generally support activities essential for other Sandia sectors' successes. Research and development activities include critical supporting sciences and crosscutting exploratory technology

---

assessments and developments. Exceptional science and technology foundations are necessary to respond quickly to problems, to facilitate movement of Sandia in new directions, to respond to technology advances, and to stimulate interactions with US industry. Important elements of the program include support capabilities (shops, engineering, drafting, and computing), specific developmental testing facilities, above-ground test facilities for radiation-effects assessments, and materials science capabilities. Key facilities and capabilities may be underutilized and yet be essential for meeting the long-term requirements of DOE national security programs. Dual-use activities provide the opportunity and the challenge to maintain essential competencies while contributing to US economic competitiveness.

4. The fourth focus area encompasses changing national security requirements, environmental and budget concerns, and the advanced age of many nuclear production facilities. These factors combine to drive the reconfiguration of the nuclear weapons complex into a smaller, more efficient, more modern, and more environmentally appropriate form. The success of these efforts will depend greatly on the development of new and appropriate production and waste management technologies, on new and more modern approaches to the integration of design and manufacturing, and on the development of appropriate alternatives for those materials and processes that must be discontinued. Sandia emphasizes commercial procurement of most parts, small-lot manufacturing of essential parts, and standardization. Sandia has accepted the transfer of important production responsibilities from other elements of the nuclear weapons complex as part of the overall downsizing.
5. The fifth focus area, nonproliferation and intelligence, has two broad but related aspects. One aspect concerns activities specifically related to monitoring and supporting arms control agreements and treaties with the former Soviet Union. These activities cover a wide range, including preparations for potential agreement concerning inspection of the stockpiles and facilities within both nations' nuclear weapons complexes. The second aspect involves monitoring and preventing the further spread of nuclear weapon technologies. As the collapse of the bipolar Cold War balance gives way to a far more dynamic multipolar world, these nonproliferation and counterproliferation responsibilities are becoming increasingly important.

The defense programs sector is also approaching its responsibilities from a second direction. In addition to recognizing vital programmatic focus areas and establishing appropriate programmatic thrusts, the sector has established some broad and enduring performance criteria against which plans and strategies can be judged and, if necessary, modified or reinforced. These are the Strategic Investment Criteria for the defense programs sector. They reflect the fundamental principles of the sector and its long-term commitment to remaining a relevant and contributing entity. The following criteria are being applied to virtually all projects undertaken by the sector:

- **Customer Obligations**—Sandia is a customer-focused organization. Its sectors' efforts and activities are routinely scrutinized and monitored for agreement with customer requirements.
- **Dual-Benefit**—The defense programs sector recognizes the need to respond to a broad range of challenges to our national interests. Thus, we are committed to a balanced program heavily focused on the exploration and development of technologies that can benefit both domestic industry and the nuclear weapons program. This approach emphasizes meeting the sector's needs in manufacturing, high-performance computing, electronics, nonproliferation, risk assessment, safety, and security. At the same time, the sector places a high priority on technology transfer to industry for the further development and maintenance of our national strategic industrial base. Cooperative technology development with industry leverages resources in areas of mutual interest and contributes to the economic competitiveness of the nation.
- **Strategic Partnerships**—The responsibilities of the defense programs sector to maintain credibility of the nuclear deterrent represent the original mission of DOE's Defense Programs laboratories. These laboratories have evolved from special-purpose sites dedicated to a single program to multiprogram institutions addressing a wide range of national interests. The impacts and effects of the increasingly competitive international environment are actually strengthening and accelerating this trend. Teamwork within Sandia and between Sandia and other national laboratories, universities, national research institutions, and the industrial sector is essential for bringing the full potential of our capabilities to bear on complex national issues.
- **Nurturing Technical Strength**—The sector maintains essential elements of national vigilance against the possibility of technological surprise. In this context,

---

the sector is obligated to continuously monitor, explore, and exercise the most modern and advanced elements of technologies likely to have an impact on the interests and security of the nation. The sector has a further responsibility to ensure that Sandia's resources are constantly challenged to grow and that the full potential of their benefit to the nation is realized.

- **Strategic Reconfiguration**—To remain national assets, the sector and Sandia continuously monitor, reassess, and realign their organizational goals, strategies, and structures, and constantly adjust their responses to dynamically changing customer requirements. In this way, we ensure that our activities reinforce the strategic directions established for Sandia and the nation.

## Assistant Secretary for Defense Programs

The Assistant Secretary for Defense Programs is the cognizant secretarial officer for Sandia. Weapons activities employ half of Sandia's direct personnel and include research and development, testing, inertial confinement fusion, stockpile support, reconfiguration, emergency response, and a variety of special projects. Furthermore, the technology base developed and preserved by the Assistant Secretary for Defense Programs underlies the Defense Programs Technology Transfer Initiative, which is also under the Weapon Activities program. Although arms control, nonproliferation, and defense waste cleanup activities are no longer a direct responsibility of the Assistant Secretary for Defense Programs, the same technology base is essential to those programs.

Activities sponsored by the Assistant Secretary for Defense Programs are concentrated on the first four focus areas of the DOE National Security Strategic Plan. Although the individual program activities described in detail below are aligned with the current budget structure, the overlap of the activities described within the focus areas is apparent throughout.

In cooperation with Los Alamos and Lawrence Livermore national laboratories, Sandia supports DOE Defense Programs in the development of a stockpile stewardship document and a stockpile stewardship program plan intended to outline strategies in an era of no nuclear testing, no new weapon developments, downsized production requirements, and longer stockpile lifetimes.

Surety is an important Sandia responsibility. It addresses issues raised by the Drell Panel<sup>1</sup>, concerns related to transportation and handling, logistical problems associated with retirement and dismantlement, requirements of a smaller and more flexible stockpile, and increased public sensitivity toward environmental

safety and health issues. Sandia's surety strategy is to embed in all of its efforts and products the principle that the surety of any product or operation, regardless of its expected service life, is too critical to be allowed to degrade and must be constantly updated.

As Sandia accepts additional responsibilities within the downsized nuclear weapons complex, our science and technology infrastructure must remain adequate to support responsible stockpile stewardship. This is a key priority within the defense programs sector.

In FY 1994, we implemented a process to evaluate every new or ongoing project to determine their potential application to the commercial sector. Faced with a decline in the direct funding that has historically supported the technology base for weapon activities, we expect our technology cooperation efforts and industrial partnerships to help preserve core capabilities necessary to carry out our defense programs responsibilities. One key reason for this policy is to link the resulting technology transfer activities to specific DOE Defense Programs projects so that substantial spin-back to the weapons program occurs. A second reason is the recognition that our defense activities will benefit directly from closer ties with industry, other governmental agencies, and universities.

## Research and Advanced Technology (GB010301)

Activities supported by this budget and reporting category provide the science and technology infrastructure (technical expertise and facilities) needed to support multiple DOE Defense Programs missions, programs, and initiatives. This category emphasizes maintenance and improvement of our understanding of the science of complex nuclear weapon systems. It also advances the technologies necessary for nuclear weapon design, engineering, production, certification, and retirement, including warhead dismantlement and the disposal of hazardous materials. The program sustains core capabilities for all atomic energy defense activities, including those falling outside the direct responsibility of the Assistant Secretary for Defense Programs, such as arms control, nonproliferation, and environmental restoration and waste management. A Munitions Technology Development Program jointly funded by DOE and DoD under a 1985 memorandum of understanding develops innovative weapon technologies of interest to both agencies.

An increasingly important mission is to facilitate technology transfer to the private sector and otherwise

---

<sup>1</sup> The Drell Panel, formally the Panel on Nuclear Weapons Safety, evaluated the safety of US nuclear weapons systems for the House Armed Services Committee in 1990.



assist US industry with precompetitive development of commercially promising technologies.

From a budgetary standpoint, the Research and Advanced Technology Program and DOE's Research and Technology Development Division (Defense Programs 11) coincide. To address its broad responsibilities, the division subdivides program activities into nine specific technology areas or program elements. The desired levels of capability in these program elements are monitored against the needs and objectives of the research and development activities that use and exercise them. Efforts to directly augment or enrich program elements are made only when programmatic activities within ongoing DOE Defense Programs initiatives are temporarily unable to fully sustain necessary capabilities.

The nine program elements in which Sandia has significant activity are discussed below.

### *Conceptual Design and Assessments*

Conceptual design and assessment, along with physics, computation, and modeling, form the core of the science of complex nuclear weapons systems and associated subsystems. The work in this program element generates and evaluates new weapon and weapon component concepts. These exploratory concepts are generally not predicated in the current requirements of the Stockpile Stewardship Initiative. Rather, conceptual design and assessment typically consist of groundbreaking projects in which new weapon and weapon component concepts are developed until they are mature enough to integrate into one of the defense programs initiatives or program elements. Thus, conceptual designs that prove promising for weapon applications (improved capability, reduced life-cycle cost, or safety advantages) remain within this program element only through proof-of-concept demonstration. They are then transferred to another program element (often to Systems Engineering Science and Technology) or to one of the programs within the Stockpile Stewardship Initiative.

The goal of conceptual design and assessment is to explore ideas with potential to support multiple defense missions, programs, or initiatives and (if successful) that will lead to advances in performance, capability, utility, and surety, or reductions in life-cycle costs. Work currently supported by this program includes methods to enhance electrical nuclear detonation safety and innovative concepts that may greatly enhance nuclear safety.

Although hardware development is not typically a major part of this activity, demonstration of concept feasibility is frequently required. The work is often computationally intensive. Current areas of emphasis include enhanced surety, alternatives to hazardous materials, new weapon capabilities, and prevention of technological surprise. Because this program element looks beyond proven concepts and traditional methods, these capabilities are of critical importance to the Office of

Nonproliferation and National Security in assessment of possible nuclear weapon proliferation in foreign countries.

### *Physics*

This program element forms a second part of the core science of complex nuclear weapons systems and associated subsystems. The laws of physics govern virtually every phase of weapon design, engineering, testing, and certification. This program element touches every aspect of maintaining a credible deterrent.

Physics provides much of the basis for the Test Ban Readiness and Stockpile Stewardship initiatives, as well as the capability for predicting the effects of nuclear explosives on military targets and the vulnerability of nuclear weapons to nearby nuclear explosions. Physical principles underlie the design and testing of nuclear weapon systems, many of the unique manufacturing processes for weapon components, and the design of facilities to test these components. These principles also govern the design of complex experiments to test weapon components, validate our understanding of how these systems function, benchmark the computer codes used to design component subsystems, and assess the safety of weapon components in accident scenarios.

### *Computation and Modeling*

This program element ensures the development and maintenance of computational capabilities essential to the design, production, testing, and certification of nuclear weapons.

A nuclear weapon is a complex system of many components and subsystems. The actions of these components and subsystems are tightly coupled when the weapon is fired. The complexity of structure, function, and interaction of these components prohibits their efficient design (at a reasonable cost) without the use of extensive computational support. In addition, these systems and components must consistently meet the most demanding requirements for safety and reliability and continue to function with high precision throughout a stockpile service life that may last several decades and involve exposure to severe environmental, handling, and transportation stresses.

After a weapon enters the stockpile, opportunities for direct inspection and testing are limited and expensive. Maintaining this extremely high level of product reliability with minimal direct testing and at reasonable cost requires computational modeling at every stage in the design, production, and service life of the weapon.

Computation and modeling are critical to every element of nuclear weapon activities, including

- testing required to assess system performance,
- experimentation to understand the underlying physics,

- correlation of simulations to actual threats,
- design of engineered materials and processes,
- control of intelligent manufacturing equipment and robotics for handling hazardous materials and assembling systems,
- safety assessments, and
- assistance with emergency response.

Computation and modeling are particularly important in several areas. Computational analysis is critical to safety assurance, which ensures that weapon systems in accidents will not fire or release hazardous materials into the environment. In addition, with testing of nuclear

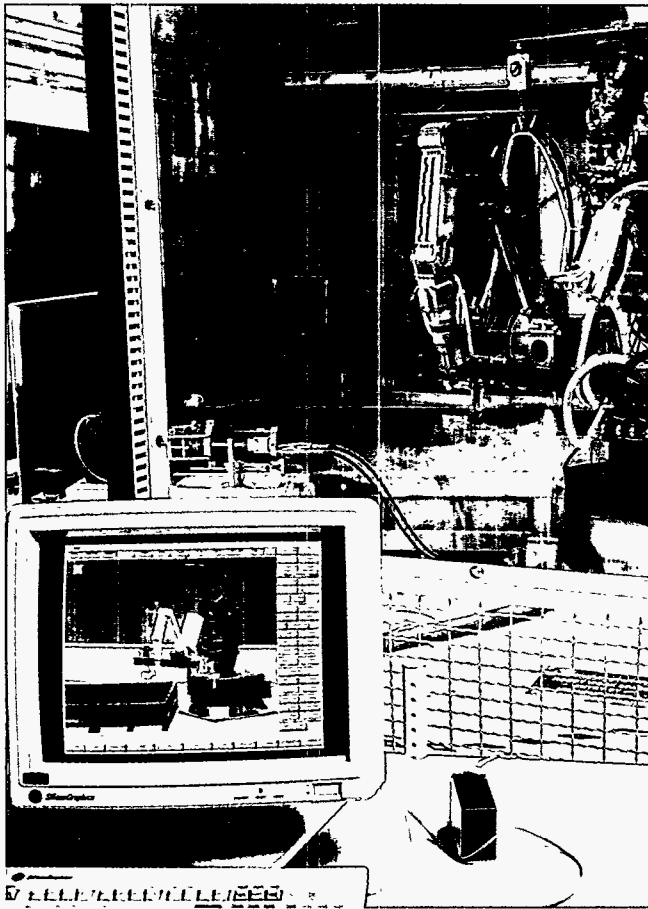

Sandia has developed and tested this remotely controlled robot for handling hazardous materials at the Hanford nuclear research facility. A human operator can view the robot's movements remotely on a computer screen.

weapons suspended, our ability to certify the vulnerability of components to radiation will be even more important than in the past. Computation and modeling are also critical in designing weapon transportation and storage systems and in evaluating weapon survivability when subjected to nuclear defense measures.

Modeling will be a fundamental tool in agile manufacturing of nonnuclear components in the reconfigured nuclear weapons complex. In the reconfigured complex, production processes will be modeled and integrated through computer-aided design and computer-aided manufacturing to ensure product reliability at low cost and low volume and to provide flexible production conditions. Computation and modeling also play a vital role in addressing environmental safety and health concerns. For example, modeling is widely used to design less hazardous substitute materials and alternative processes.

Virtually all DOE missions are heavily dependent on computation and modeling. The Office of Nonproliferation and National Security and the Office of Environmental Restoration and Waste Management rely on the capabilities maintained by this program element. In the broadest terms, simulation and modeling of complex systems reduce overall program costs by assisting with risk reduction early in the system life cycle and reducing the need for physical testing.

### *Systems Engineering Science and Technology*

This program element assembles and integrates fundamental technologies to create core products and capabilities that anticipate shifting requirements, keep pace with the rapid evolution of technology, and meet critical systems needs of DOE. This ensures the maintenance of comprehensive systems engineering and production capabilities essential to supporting and integrating multiple research and technology development programs.

The boundaries between systems engineering science and technology and some of the other program elements are not always sharp. However, this program element emphasizes the integration of multiple technologies, many of which are developed through other program elements or through DOE Defense Programs initiatives. Other program elements focus on development of a specific set of technologies to meet a specific set of performance goals. The systems engineering science and technology element has the more comprehensive goal of selecting from alternative technologies and integrating them to yield desirable characteristics in broad systemic categories, including manufacturability, affordability, environmental safety and health, dismantlement and disposal, certification, and maintenance of core product capabilities.

An important consideration in selecting activities for this program element is the need to constantly introduce

new or emerging technologies into mainstream design and to regularly update, assure, and modernize the technology of the stockpile. To meet this need, system engineers examine the work being done in other program elements and initiatives in areas that best support DOE's strategic needs and intent. Conceptual design and assessment are monitored with particular care to identify new concepts that have the greatest potential for further development. High priority is then given to development of enabling technologies to support these promising concepts. Although general scientific and technological feasibility is determined in conceptual design and assessment, engineering and production feasibility and the merit of each new concept are assessed in system engineering science and technology.

Most importantly, this program element maintains the design, engineering, and testing infrastructure needed to sustain and enhance the stockpile and to respond to new challenges.

Systems engineering science and technology also benefit a number of other defense missions within DOE, including programs for safe and secure transportation of weapons, physical security of weapons and materials, dismantlement, and arms control.

### *Electronics, Photonics, Sensors, and Mechanical Components*

Electronic, mechanical, and aerodynamic components largely determine the precision of weapon delivery to a target, the reliability of the system, and the operability of weapons in the potentially severe environments encountered during delivery. Special-purpose electronic components in nuclear weapons include coded switches that prevent unauthorized use, tamper detectors, programmers that control the arming and firing sequence of the weapon, radars, and fuzing and firing sets. These devices must operate reliably over a large temperature range, survive strong mechanical shock, and be fully functional following exposure to intense pulses of ionizing and electromagnetic radiation caused by nearby nuclear detonations. The latter may be caused either by defensive systems of the targeted country or by fratricide.

Many of the requirements for devices cannot be met with commercial electronic products. This limitation is also true for many of the mechanical and aerodynamic components that determine the reliability of a weapon after an extended period of time in stockpile.

Photonics is an emerging technology that uses visible-light energy for functions normally performed by electrical energy. Because of their inherent immunity to electromagnetic interference and their tolerance to the effects of ionizing radiation and intense pulses of electromagnetic radiation, photonic devices offer unique advantages over electronic devices for a wide variety of applications in nuclear weapons.

Photonics is the enabling technology in the optical

firing set, which is being researched as a possible replacement for the traditional electrical system. This firing set offers greatly enhanced safety should a weapon be exposed to severe abnormal environments such as a crash or a direct hit of lightning. It uses a laser and optical fibers to initiate detonators that in turn initiate the nuclear explosion. It also lends itself to unique photonic-based use-control subsystems that would greatly reduce the threat of unauthorized use if a weapon fell into the hands of another nation or terrorists.

Although research in enabling laser photonics technology has been performed under this program element, the explosives program element develops the technology. Following proof of feasibility and practicability, development moves to the system engineering science and technology program element for full-scale engineering and certification.

Sensor research and development in this program element include radars used to command the firing of a weapon and provide precision terminal guidance, components that detect unauthorized tampering, use-control devices, accelerometers, and chemical sensors to assess the condition of weapons in stockpile.

The technology base in this program element is critical to almost every DOE defense mission, initiative, and program. Satellites that monitor compliance with international arms control agreements require microelectronic devices hardened against the ionizing radiation of space. Application-specific microprocessors and embedded computers are needed by many of the systems used to verify treaty compliance and assess activity in foreign countries that may indicate work on weapons of mass destruction. Also, advanced sensors such as chemical microsensors, light detecting and ranging (lidar) systems, and high-performance synthetic aperture radars developed in this program element offer new capabilities for arms control and proliferation assessments.

The technologies above are also critical for DOE's safeguards and security effort. Chemical sensors and lidar can assess chemical hazards in nuclear waste sites in support of programs of the Office of Environmental Restoration and Waste Management. Many of these capabilities are of primary importance in the emergency response program of DOE. Furthermore, strengths in electronics, microelectronics, and photonics in this program element are promoting national technology leadership through technology transfer.

### *Chemistry and Materials*

Meeting the demanding reliability, safety, and physical security requirements of nuclear weapons requires a diverse range of materials expertise and capabilities, many of which are unique to the nuclear weapons laboratories. Nuclear weapons must operate reliably in the severe environments of strong mechanical shock, intense electromagnetic fields and ionizing

radiation, and large temperature excursions. Also, they must not detonate or disperse nuclear materials in accidental exposure to severe abnormal environments such as fire, mechanical shock, electrical shock and static charge, electromagnetic pulses, or their combinations. In the future, reliability must be certified without full-scale underground testing. The activities supported by this program element are central to meeting these requirements.

This program element also maintains the infrastructure needed to assess materials-related deficiencies uncovered in weapons in stockpile. Such troubleshooting and failure analysis require special expertise and capabilities because of the special nature of many of the components.

Meeting the materials development and analysis requirements for nuclear weapons engineering and stockpile support requires broad strengths in synthesis, processing, materials characterization, theory, modeling, and simulation. This knowledge base must span a wide range of materials, including metals, ceramics, glasses, organics, composites, and semiconductors (semiconductor materials are included in the electronics, photonics, sensors, and mechanical components program element).

Current activities focus on materials and process substitution to reduce the cost of component production and weapon dismantlement, produce longer-lifetime components to reduce maintenance requirements for weapons in stockpile, ameliorate or eliminate sources of harmful effects on the environment, and achieve the highest safety in the workplace. These materials technologies are a cornerstone of the evolving agile product realization process.

The technologies and facilities sustained by this program element directly benefit many DOE defense projects that fall outside the direct responsibility of the Assistant Secretary of Defense Programs. Projects under the direction of the Office of Environmental Restoration and Waste Management and projects supporting safeguards and security initiatives are also direct beneficiaries. Both programs have needs for special-purpose materials and processes, and each relies heavily on the materials characterization capabilities sustained by this program element.

### **Tritium**

Tritium is an essential material in current nuclear weapons. Sandia's activities in this program element include the design of tritium reservoirs and associated gas transfer systems. These systems require bottles, valves, actuators, and piping designed for long life under extremely high pressure. Fundamental and applied research on materials degradation in these systems is performed by the chemistry and materials program.

Tritium is radioactive and has a half-life of 12.3 years.

As tritium decays, helium is produced, which invades and weakens the containing material. Research on improved alloys for reservoirs and neutron generators, stable storage of tritium, and management of the decay product should lead to greater lifetimes for these components, improved safety, and maintenance cost savings.

### **Explosives**

There is great need for improving the performance and safety of explosives and associated components. Understanding the processes of localized mechanical and thermal energy buildup and dissipation for all kinds of abnormal stimuli is paramount in evaluating safety and performance. This program element must study trade-offs of availability and cost, dynamic and mechanical properties, chemical and thermal stability, initiability, durability, environmental concerns, and issues associated with the inevitable retirement, recycling, and disposal of assemblies containing explosive materials. From these studies will emerge safer high-energy explosives and improved performance.

Activities range from fundamental physics and chemistry of explosive materials to prototype engineering of explosive components and their evaluation for weapons uses. Retirement of systems and disposal of materials must be considered at all phases in the cycle. Normally, after a new concept proves to be feasible, full-scale engineering and certification are performed under the stockpile stewardship program or by the system engineering science and technology program element. Current emphases include firing systems that offer greatly enhanced safety (e.g., direct optical initiation firing sets employing lasers and optical fibers) and a concept for physically separating the explosive material from the nuclear assembly until authorized.

The technologies and infrastructure sustained by this program element are of direct benefit to many DOE defense projects that fall outside the direct responsibility of the Assistant Secretary for Defense Programs. The Office of Environmental Restoration and Waste Management takes advantage of the research and development related to explosives characterization and demilitarization processes in the environmental restoration of DOE sites contaminated by explosives and their by-products. The safeguards and security program uses databases on explosives and computational models to assess the vulnerability of transportation systems and to design transportation containers. The stockpile support program will benefit from the development of explosives that have longer lifetimes and will lower costs for both production and disposal.

### **Dual-Use Benefits**

Activities in the above program elements have made

possible a large number of technology transfers to the private sector, including many cooperative research and development agreements with private companies. These agreements have resulted in a large number of enabling, precompetitive technologies and manufacturing processes that have been commercialized. Our past success in identifying dual-use opportunities in weapons research and development and working with industry to transfer capabilities to them provides the basis of our new policy that every project will integrate dual-use technologies during implementation. Selected examples of recent dual-use successes are listed below:

- Research on plasma etching systems used in the manufacture of microelectronic devices to define transistor features and electrical interconnects between transistors led to an explanation of why seemingly identical systems occasionally do not function identically and why the response surface of a specific system sometimes changes. Solutions by our staff are now incorporated in commercial equipment.
- A new process to produce printed circuit boards without using ozone-depleting chlorofluorocarbons was developed by Sandia engineers working with Motorola. This process has the potential to eliminate more than 25 percent of the worldwide release of such compounds into the atmosphere.
- Sandia's advanced understanding of the parameters of welding and development of enhanced adaptive process-control sensing and protocols has been transferred to industrial partners. Ongoing activities are aimed at integrating predictive models into both computer-aided design and adaptive control instrumentation.
- Semiconductor strained-layer superlattice materials pioneered by Sandia have led to a new generation of microelectronic and optoelectronic devices with improved performance. Commercial devices (including next-generation cellular telephones by Motorola) based on these new materials are beginning to reach the marketplace.
- Sandia's advances in protecting microelectronic circuits from ionizing cosmic radiation and energetic particles are used in the manufacture of robust electronic systems for satellites. Their use reduces the incidence of single-event upsets of microelectronic circuits, which cause both functional and informational losses.
- Sandia's expertise in weapon surety assessment and

certification methodologies, nondestructive testing, and materials analysis, testing, and evaluation is being used to evaluate the structural safety of aging aircraft.

### *Stockpile Stewardship (GB010302)*

A principal mission of Sandia is stockpile stewardship, which encompasses directing and managing the total life cycle of the nuclear weapons stockpile and maintaining a viable weapons component capability. Duties include the following: maintaining the weapons in the stockpile; monitoring, testing, and assessing stockpile health; developing and retrofitting nuclear weapons as required; developing and maintaining equipment required to support nuclear weapon logistics and operations; developing and maintaining capabilities for safe and secure transportation and storage of nuclear weapons; and supporting the dismantlement of nuclear weapons retired from the stockpile.

### *Weapon Development*

In today's world, Sandia's principal thrusts in the weapon development program are to support downsizing the nuclear weapon stockpile, ensure the continuing health of weapons remaining in stockpile, identify areas where stockpile surety improvements should be made, support DOE and DoD in incorporating surety improvements to the stockpile, and support DoD requirements for improved operational capabilities. In support of these thrusts, the objectives of the weapons development program at Sandia are to

- provide stockpile stewardship leadership in support of DOE and DoD,
- ensure that all programs and projects are customer-oriented,
- ensure that DOE resources are applied to current and anticipated DOE/DoD requirements,
- maintain a credible nuclear weapon stockpile by enhancing surety (safety, security, and control) and operational flexibility,
- support an expanded DOE role in the logistics and maintenance support of the stockpile
- support dismantlement of nuclear weapons, and
- maintain within Sandia a viable weapon component development capability (and supporting technologies) to ensure the continued health and support required improvements of the stockpile.

Nuclear weapon development at Sandia is carried out in close cooperation with Los Alamos and Lawrence Livermore national laboratories, which design the nuclear explosive subsystems. Sandia integrates the nuclear explosive subsystem with many Sandia-designed components to achieve the desired military capabilities, and certifies the required radiation hardening of all nonnuclear DOE components in a weapon system.

Sandia works closely with DoD in the critical area of weapon surety. Component manufacture and weapon assembly are performed by other DOE contractors using design definitions furnished by Sandia, Los Alamos, and Lawrence Livermore national laboratories.

Sandia's principal nuclear weapon responsibilities include the following: safing, arming, fuzing, and firing systems; use-control systems; external neutron initiation systems; gas transfer systems; delivery system interfaces; military liaison; stockpile support; and related testing and instrumentation. In addition, Sandia is responsible for ancillary equipment used worldwide by DoD to support nuclear weapon operations in the areas of use control, handling, shipping, storage, and maintenance.

Nuclear weapon development programs may be initiated to correct problems or improve weapons in the stockpile or in the ancillary equipment that supports weapons in the stockpile. New nuclear weapon systems may be developed in response to changing military requirements. Whether for existing weapons or new weapon developments, Sandia, Los Alamos, and Lawrence Livermore national laboratories work on behalf of DOE in support of DoD requirements. The laboratories work closely with DoD to understand their requirements for nuclear weapons and develop solutions. The requirements and needs are the basis for development activities at Sandia.

The DOE Defense Programs laboratories and production plants are responsible for the design, development, testing, certification, production, maintenance, stockpile surveillance, and retirement of the warheads and ancillary equipment provided to DoD by DOE. In addition, the laboratories and the production plants are responsible for providing the retrofit kits (components and materials) used by DoD to upgrade weapons in the stockpile. These life-cycle activities occur in seven phases:

- Phase 1 evaluates new concepts and advances in technology for possible application to nuclear weapons.
- Phase 2 is a technical feasibility study examining the military requirements and cost-effectiveness of a new weapon system.
- Phase 2A is a detailed design and cost study for a selected system.
- Phase 3 commences when DoD or DOE decides to

proceed with a weapon system. It involves the engineering development work for the life cycle of a nuclear weapon, including overall design definition and component development.

- Phase 4 is production engineering. Design and manufacturing development are completed, and environmentally conscious manufacturing processes are established.
- Phase 5 begins with first production. These first units are rigorously checked in the laboratory and in the field. Ancillary equipment and manuals are completed.
- Phase 6 is quantity production of the weapon and maintenance of the weapon in the stockpile. Upgrades or modifications may be performed if required. Stockpile evaluation sampling and surveillance continue throughout stockpile life.
- Phase 7 retires the weapon from the stockpile and reclaims nuclear material and reusable parts.

Sandia is involved in all of these phases of the life cycle of nuclear weapons. Applied research and development is the principal activity in Phases 1 through 4 and continues to support the stockpile activities of Phases 5 through 7.

### ***Stockpile Evaluation, Maintenance, and Support***

Sandia supports the DOE Stockpile Evaluation Program by analyzing and testing weapons as they enter the stockpile and by evaluating weapons withdrawn from the stockpile. Results from the evaluation program clearly indicate that nuclear weapons do not wear out. However, weapons do age. As the stockpile ages, Sandia and the nuclear design laboratories take corrective action to ensure that performance and safety of the stockpile do not degrade. Corrective actions can take the form of changes during new weapon construction or retrofits to weapons in the stockpile.

The evaluation program has shown over the last four decades that serious defects in nuclear weapons have been relatively rare. As defects or problems are identified, changes are made to improve operations and maintenance. Sandia's Stockpile Evaluation Program relies heavily on the basic skills required to develop nuclear weapons. Among these skills are materials science, electronic piece-part and subassembly design, electro-mechanical component design, structural design, applied mechanics analysis, and environmental testing.

During the last four decades, approximately 13,500 weapons in the stockpile have been tested. A total of 2,344 defects has been found, a portion of which could

be categorized into 252 actionable defect types. Actionable defects are those that impact reliability or safety and require corrective action. Overall, stockpile reliability has been excellent for the last forty years.

An important future thrust for this program will be to refine the sampling and testing program to ensure that the reliability and surety of the stockpile are maintained at a high level as the stockpile is reduced in size.

Sandia provides the technical military manuals and training that enable the armed services to maintain stockpile readiness while ensuring safety and control. Training is conducted at Sandia for military logistics

specialists who, in turn, train other military personnel. Sandia also provides on-site field training for the military in response to their needs and requirements.

Most weapons require periodic maintenance, such as replacing limited-life components. Sandia supports this routine maintenance requirement through the Training and Technical Manuals Program and with field engineering staff as appropriate. When problems with nuclear weapons occur in the field, Sandia provides technical support to the military to resolve them. In most cases, problems are resolved in the field without having to return weapons to the DOE production complex.



A nuclear weapon parts shipping container is displayed and explained at DOE's Pantex nuclear weapon assembly/disassembly plant in Amarillo, Texas. The nearly indestructible container is being checked to ensure that it is completely leak-tight before any parts go into it for shipping.

## ***Retirement, Dismantlement, and Storage***

National policy and DoD requirements establish weapon retirement schedules. After the dissolution of the Soviet Union and signing of the START agreements, the size of the US nuclear stockpile has been and will continue to be reduced. Many weapons are being retired, and more than 10,000 weapons will be dismantled by the DOE production complex during the next ten years. Dismantlement will be a major effort and Sandia is providing significant support to DOE for this task.

Dismantlement begins when the military designates a weapon for retirement and ends when DOE has disposed of the weapon components, trainers, handling equipment, and associated hardware. The procedure includes transportation, storage, and disassembly into subsystems and components that are recycled, staged for reuse, or disposed.

Many issues must be addressed by Sandia to support dismantlement. Where and how will weapons be safely and securely stored while awaiting dismantlement? How will materials be safely and securely transported? What are the best approaches for the safe dismantlement of large quantities of weapons and disposal of weapon materials while ensuring the environmental safety and health of the work force, facilities, and public?

Sandia has development programs to address such issues. These programs are coordinated by the DOE Albuquerque Operations Office with DOE's Pantex plant in Amarillo, Texas to ensure that safe and efficient processes are developed.

Sandia is developing automated processes using robotics and computer modeling to support dismantlement. In particular, the Stage Right Project is under way to establish feasibility of a robot system for materials movement and inventorying. Stage Right will move, stack, and retrieve fissile pits from dismantled nuclear weapons. In addition, the system can remotely inventory pits in storage. This system will permit higher pit storage densities in facilities while eliminating the requirement for personnel to enter storage facilities for material handling and inventory. Thus, personnel can avoid exposure to radiation environments within pit storage facilities.

In addition, we conduct joint projects with DoD to examine methods of disposing explosive and energetic components and materials and of using robotics for disassembly and dissection of electronic components. Studies of automated hazardous material removal systems, robotic disassembly of explosive components, and arms control are also under way. The payoff could be a modern, safe, and cost-effective dismantlement operation at Pantex with possible dual-use applications for US industry.

## ***Studies, Engineering Development, and Technology Demonstrations***

### ***Studies***

Planning is under way for stewardship of the enduring US nuclear weapons stockpile. Strategic objectives are as follows: to reduce the nuclear danger; to maintain US abilities in deterrence and nonproliferation strategies through research, design, development, and manufacture of nuclear weapons; to keep the stockpile modern, safe, secure, survivable, and ready; and to support options for new missions.

Changing missions and unprecedented constraints have been imposed by recent world and national events, including reduced emphasis on mutually assured destruction as a deterrent doctrine. Other issues include cessation of underground nuclear testing, major changes in the nuclear weapons production complex, and an emerging threat to the world posed by the proliferation of weapons of mass destruction. These issues demand a new approach to stockpile stewardship, to be realized through new and viable design options, new tools, and a program plan for maintenance and modernization.

The former paradigm of Phase 1 concept studies and Phase 2 feasibility studies is largely being replaced by less formal taskings that relate to the foregoing issues. The High-Power Radio Frequency Phase 2 study is in its final year. The Sea-Launched Strategic Systems Phase 2 study is in its concluding stage. Newer taskings address robustness, long life, command and control, and nonproliferation. The revolutionary surety measures identified in a recently completed Phase 1 study are now being considered in the newer studies.

### ***Engineering Development***

A number of engineering development projects are under way in direct support of weapons currently in stockpile. The driving forces behind such projects are one or more of the following: surety soft spots (i.e., areas where safety or use control should be improved to be consistent with modern safety requirements and evolving adversary threats to weapons); reliability soft spots (i.e., areas where reliability reductions are either identified or anticipated); stockpile changes that require new approaches for ensuring continued support of DOE's stockpile evaluation program (i.e., replacing flight instrumentation systems with those that can obtain the required flight test data); components to support required future limited-life component change-outs; and replacement of use-control equipment that has either reached the end of its life or has vulnerabilities that should be corrected. In each case radiation survivability is designed into changes or modifications and certified in simulator testing as required. Examples of these projects are listed below:



- The B83 strategic bomb quality improvement program will provide an encrypted recode permissive link (modification 1) and quality, safety, and use control upgrades.
- The B61 bomb modifications 3, 4, and 10 field safety retrofit will incorporate an upgraded safety trajectory sensing device.
- The B61 bomb modifications 3, 4, and 10 field use/control upgrade will provide an encrypted recode permissive link and secure inventory capability.
- B61 bomb modifications 3, 4, and 10, and the B83 bomb modification 1 field upgrade will provide a dual-channel radar.

- Joint test assemblies (including instrumentation redesign as appropriate) for the enduring stockpile will be brought into compliance with DOE directives.
- The W78 and W87 joint test assemblies redesign will provide both missile and warhead performance data collection for the Minuteman III application.
- The W76 warhead neutron generator detonator will be upgraded.
- Limited-life components will be developed and fabricated for the enduring stockpile.
- Secure recode systems' ancillary equipment will be developed for the US Strategic and European Commands.

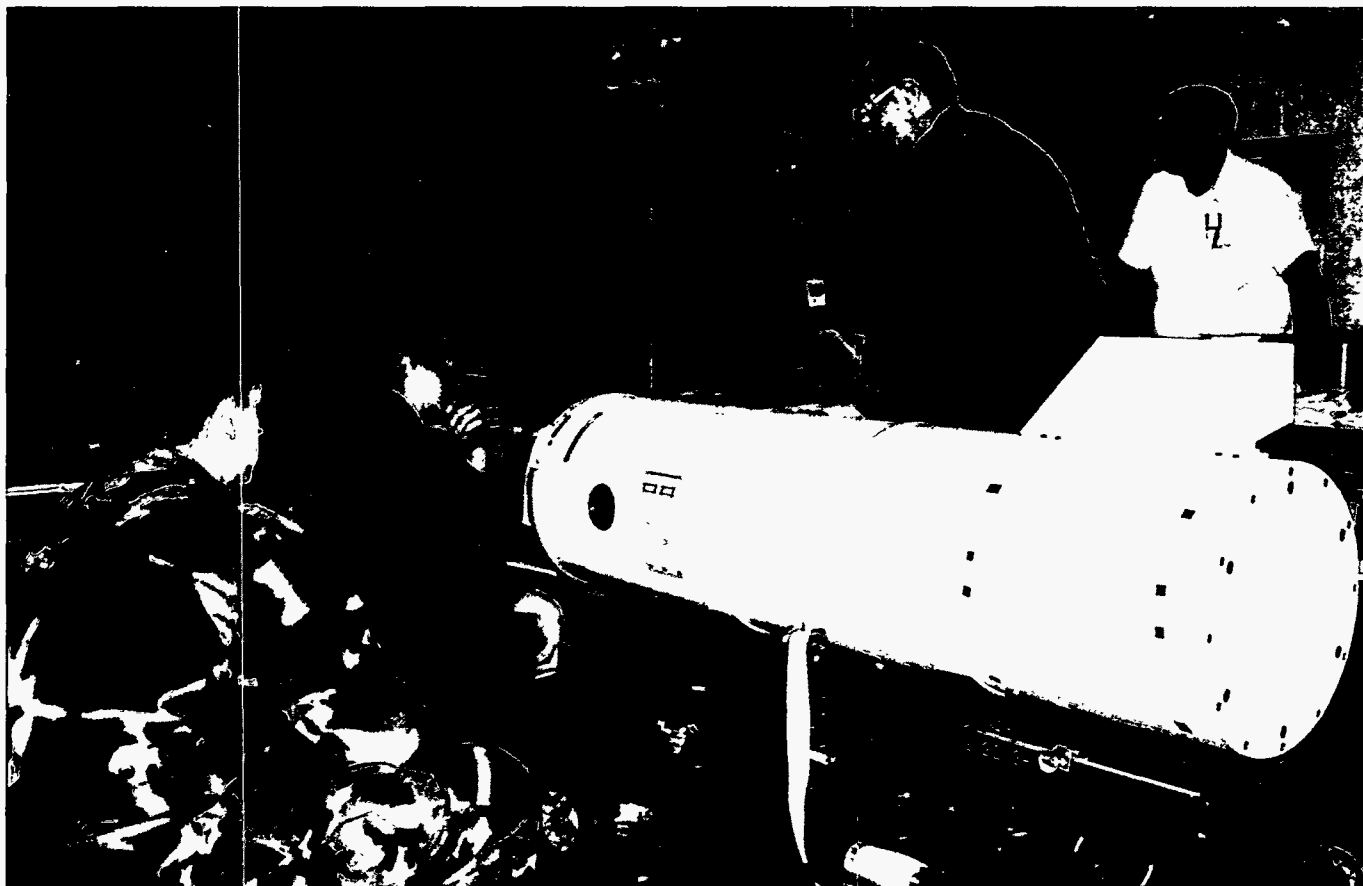

Sandians conducted training sessions at US Air Force bases as part of the spin rocket motor retrofit for the B83 strategic bomb.

### *Technology Demonstrations*

Development engineering for new weapons or for improvements to weapons in stockpile occurs in Phase 3. No Phase 3 projects are in progress. During the FY 1995 through 2000 time frame, we are planning to support requirements, as needed, for systems with greatly enhanced surety features. We are preserving our essential development engineering competencies through internal programs in technology maturation and systems engineering.

The Pit Reuse for Enhanced Safety and Security (PRESS) program is a technology demonstration program that can provide near-term options to upgrade the surety of the nuclear weapons stockpile by developing and demonstrating enhanced warhead surety possibilities. The program helps preserve US nuclear warhead competence by coordinating the essential technical capabilities at the laboratories and production agencies. Interagency product realization teams are working to prioritize workloads and responsibilities within the complex to achieve a more cost-effective weapon development process. The program employs modern quality methods, integrated design and manufacturing techniques, and environmentally conscientious materials and processes.

PRESS is being developed for multiple applications, and the current point-design is a backup option for cruise missile systems. This defined set of system requirements (along with specified, staged qualifications milestone dates) provides the necessary program direction to realistically exercise the complex. The warhead design will meet the highest achievable standards of surety. The warhead is being designed to be responsive to the Drell panel and fail-safe and risk reduction study recommendations and DOE surety policy. It is also being designed to meet the highest achievable standards of reliability and maintainability while remaining compatible with the current cruise missile systems. The elements and technologies are widely applicable in the enduring stockpile, and the program emphasizes development for multiple applications. As the chosen point-design matures, the PRESS program will use the next generation of advanced surety technologies to provide systems support to a continuously improving stockpile.

### *Enhanced Surety*

Surety includes safety, use control, and security. Several developmental activities under way will enhance surety for the nuclear weapons stockpile and will improve capabilities in new weapon developments that may be required in the future.

### *Weapon Nuclear Safety*

Safety is of paramount importance in warhead development. Safety design provides predictable, safe response at all times, even during and after unpredictable

events such as accidents.

Safety is achieved through a combination of design features. The nuclear explosive, detonators, and other critical components of a warhead's electrical system are contained in an exclusion region isolated from power sources by physical barriers. The transfer of energy through the barriers for normal operation is controlled by strong link components to ensure electrical isolation in abnormal environments. Other vital components are designed as weak links that become irreversibly inoperable in accidents at levels well below the projected failure levels for strong links.

Weapon safety is an increasingly critical area involving issues raised by the Drell Panel in 1990. Concerns included transportation and handling, the logistics of retirement and dismantlement, and sensitivity to the environment, safety, and health.

Sandia has begun a major safety technology and engineering program to enhance safety architectures for future nuclear weapons. The long-term goal is to bring new safety technology for warhead designs and components into weapon product lines, provide improved analytical tools for modeling weapon systems response in abnormal environments, and assess probabilistic risk.

A project for improving electrical detonation safety will provide the technology to enhance safety in future committed development programs and stockpile improvement programs. Improvements are focused on safety enhancements and manufacturability. This activity includes the development, demonstration, and evaluation of advanced electrical nuclear detonation safety systems. Improved exclusion-region barriers, weak links, strong links, environmental sensing devices, lightning-arrest connectors, and trajectory-sensing signal generators are being developed.

Significant improvement in nuclear safety will be realized if electrical firing sets can be replaced with optical subsystems in which the high-power signals required to initiate detonators are transmitted as photonic energy carried by optical fibers, rather than as electrical energy. The weapon detonators are designed to fire only when proper and sufficient photonic energy is applied. There will be no path to the detonators for electrical energy. The required level of photonic input does not occur in nature and cannot be created by an accident. As part of Sandia's direct optical initiation project, a prototype optical firing system has recently been developed and is being used to determine operability in various weapon environments.

In a related area, we have recently completed exploratory development of laser diode ignition technology, which uses low-power optical signals for controlling and initiating various weapon pyrotechnic functions. By using optical fibers to transmit the ignition stimulus from the laser diode to the energetic material, concerns over

---

electrostatic discharge, electromagnetic susceptibility, and conductance after fire are eliminated.

An improved detonator safety strong link is being tested to reduce potential lightning paths to the detonators, reduce costs, and improve manufacturability. In the next three years, the design of trajectory-sensing signal generators, advanced solenoid mechanisms, and mechanical weak links will be improved. We anticipate continuous improvement in electrical nuclear detonation safety architectures.

Sandia's probabilistic risk assessment technology development project will improve probabilistic risk assessment of nuclear weapons subjected to abnormal environments. The ability to identify vulnerabilities in designs and set priorities in safety technology research and development will be improved by these methods. In the next three years, an initial methodology suitable for routine use in risk assessment of nuclear weapons subjected to abnormal environments will be completed.

### *Use Control*

Weapon use control and physical security are complementary measures contributing to weapon surety.

Weapon use-control features and use-control ancillary equipment support the national nuclear command and control system to ensure that nuclear weapons can only be used when authorized by the President. A number of Sandia projects support DoD and DOE consistent with the national nuclear command and control system as defined in the 1987 National Security Decision Directive signed by the President. Sandia is the principal laboratory supporting DOE in fulfilling these responsibilities.

Sandia pioneered the development of permissive action links to provide use control. A permissive action link is a coded device within a weapon that protects against terrorists or persons with access authority but without command authority. In the early 1960s permissive action links were introduced into US nuclear weapons deployed overseas. Sandia continues to advance the design of permissive action link devices and use-control ancillary equipment to provide greater operational capability and flexibility as well as improved use control.

Sandia recently developed a new permissive-action-link coded switch that will support recode and verification operations with encrypted communications. This new device, the code-activated processor, began production in 1989 and is now being incorporated as a surety upgrade in the B83 bomb. The code-activated processor will significantly improve code security for all permissive-action-link operations and will significantly enhance operational command and control flexibility for military commanders and national decision authority.

Sandia is now developing a variant of the code-activated processor that can be incorporated in weapons with an existing permissive-action-link coded switch. This new device, the multiple-code switch encryption translator (MET), can be incorporated into weapons with a field retrofit, resulting in significant savings compared to returning the weapons to the DOE production complex for factory modification. The code-activated processor and MET cryptographic permissive-action-link devices will enable DOE to meet DoD requirements and statements of need for end-to-end encryption within weapons that contain permissive-action-link use-control.

Modern permissive-action-link coded switches have two components: an electronic component for code storage and processing (such as a code-activated processor and MET), and an electromechanical output device component. A replacement being developed for the current output device will be available to support surety improvements for existing and new weapons.

Sandia is developing a secure recode system (use-control ancillary equipment) for the Strategic Command that will support encrypted recoding of weapons' permissive-action-link devices. This system will meet an Air Force requirement for a new secure permissive action link.

In addition, an encrypted secure recode system is being developed to support all nonstrategic weapon recode operations. This theater secure recode system will provide the military with greater permissive-action-link code security and enhanced management flexibility and efficiency for the nuclear weapons stockpile and any future weapons deployments. This system will meet statements of need from military commanders and high-level studies such as the DoD fail-safe risk reduction study.

The most effective protection against unauthorized use is an active protection system. An active protection system is composed of sensors that detect unauthorized access to weapon components. When unauthorized access is detected, the system automatically disables the weapon. The recently completed fail-safe and risk reduction study recommended that weapon use control be improved. Therefore, technologies are being developed to support the incorporation of this important capability in a wider range of weapons than was possible in the past.

Nuclear command and control system architectures are being studied in three separate but related projects. The first project entails characterizing and refining architectural elements to meet present, near-term, and future nuclear command and control requirements. The second project will develop and prototype advanced command and control elements in a nuclear command-and-control test bed. The third project will be the first application of the test bed to develop and demonstrate remote, real-time permissive-action-link recode and remote, real-time inventory and command disablement.

In a broader command and control sense, Sandia provides support directly to DOE Headquarters for command and control initiatives. In 1990, DOE published its use-control policy in response to the Nuclear Command and Control System Decision Directive of 1987, which established national policy and government agency requirements. The DOE use-control policy requires a system of integrated positive measures within DOE to prevent unauthorized use of nuclear weapons in DOE custody.

At the request of DOE, Sandia established assessment teams with representation from Los Alamos and Lawrence Livermore national laboratories and DOE management for DOE facilities for which assessments are being conducted. An assessment was completed in 1992 for operations at the Nevada Test Site. This assessment was conducted for the DOE Manager at the test site. An assessment is currently under way for the DOE Albuquerque Operations Office transportation system.

### *Weapon Security*

Weapon security protects against unauthorized access to nuclear weapons. Security systems include sensors, alarms, communications, and penalty responses integrated into weapon transportation systems and weapon storage installations.

Sandia is developing systems for enhancing the security of weapons in DOE custody during transportation. One project is developing a replacement for DOE's safe secure trailer, used for transporting weapons and weapon materials. Another project is developing advanced sensors, alarms, and communications for application to DOE fixed installations or (on a reimbursable basis) to DoD for military installations and deployable site security systems.

### *Stockpile Improvement Programs*

Every year, DOE and DoD review the stockpile surety status to identify areas for improvement. These reviews may result in stockpile improvement programs within DOE and DoD. In addition, needed improvements are identified through the normal exercise of Sandia's stockpile stewardship, which can result in Sandia generating a product change proposal for a weapon in the stockpile. The product change proposal is coordinated with DOE and DoD, and if approved results in a stockpile improvement program.

Two stockpiled weapons are currently in stockpile improvement programs. The B83 bomb is being upgraded at Pantex in the areas of reliability, safety, and use control. A new safety device (a trajectory-sensing signal generator) is being developed for the B61-3,4 bomb. The new safety device will be incorporated in the B61-3,4 stockpile weapons by a field retrofit starting in 1995. Plans are also being finalized to incorporate a cryptographic permissive action link during the safety retrofit as

a use-control upgrade.

Future stockpile improvements will occur as needed to meet military requirements and address surety concerns.

### *Stockpile Technology*

Nuclear weapons use a large number of electronic, mechanical, and electromechanical components. Most of these components are unique, in that their function or some significant aspect of their environmental capability is not available from commercial sources. The capability to develop and maintain essential core products must be retained.

Each core product has some unique technology or property necessary for its function in a weapon. These products include explosive components and detonation systems, batteries, electromechanical components, microelectronics and optoelectronic subsystems, neutron generators, switch tubes, reservoirs and valves, radars, and electrical interconnections.

Advanced electronic subsystems provide many modern surety features and functional control in nuclear weapons. Use control is provided by miniature electronic locks deep within the weapon and by sophisticated operator-interactive controllers used to manage and enter release codes to unlock the weapons after Presidential authorization. Trajectory-sensing electromechanical subsystems discriminate between the intended-use environment and abnormal environments and may produce unique signals for driving stronglink switches or otherwise permitting the final arming and firing of a weapon. The firing signals themselves are developed by electronic firing sets. Embedded microcomputers control various weapon components, fuzing, and other functional characteristics. In bombs and some warheads, fuzing may be done by timers or radars developed and manufactured by DOE. Electronic subsystems are used extensively in the evaluation of stockpiled and developmental weapons.

Arming, fuzing, and firing systems make use of a variety of weapon subsystems such as radars, programmers, firing sets, trajectory sensors, and contact fuzes. The requirements for versatility, reliability, and accuracy of a smaller stockpile demand continued fuzing advancements. Advanced sensors and hardened guidance and control components will be needed to accurately navigate weapons to mobile targets and to avoid countermeasures. Development will focus on the full spectrum of potential missions in a changing world, with attention to the role of commercial industry and technology transfer opportunities.

Sandia also develops and designs gas boosting systems for many of the nuclear weapons in stockpile. We expect the need for reservoir design and surveillance to persist so long as tritium reservoirs are in the stockpile. Consequently, we will continue to improve our understanding

of metallurgy and fabrication for reservoir components, focusing on degradation associated with prolonged tritium exposure.

More work needs to be done on performance criteria in design and production, and also in the chemistry and physics associated with the aging of metals and alloys. This work will advance our understanding of the major fabrication processes—metal joining (welding) and forging. This understanding will facilitate the selection of commercial suppliers, reduce reliance on long-term aging tests to certify new vendors, and increase stockpile surety.

The current weapon component development process

will be strengthened in two ways. First, applied research and advanced development will focus on technologies critical to meeting weapons program priorities (e.g., surety). Ongoing and new projects with the Focal Point and Surety Technology programs will help focus resources on critical technologies and system architectures that address multiple nuclear weapon needs. Second, we will strive for greater continuity in the products developed. Product lines will increasingly consist of standard and modular components. The goal is more rapid and flexible response to new weapon system needs and reduced weapon development and production cost and risk.

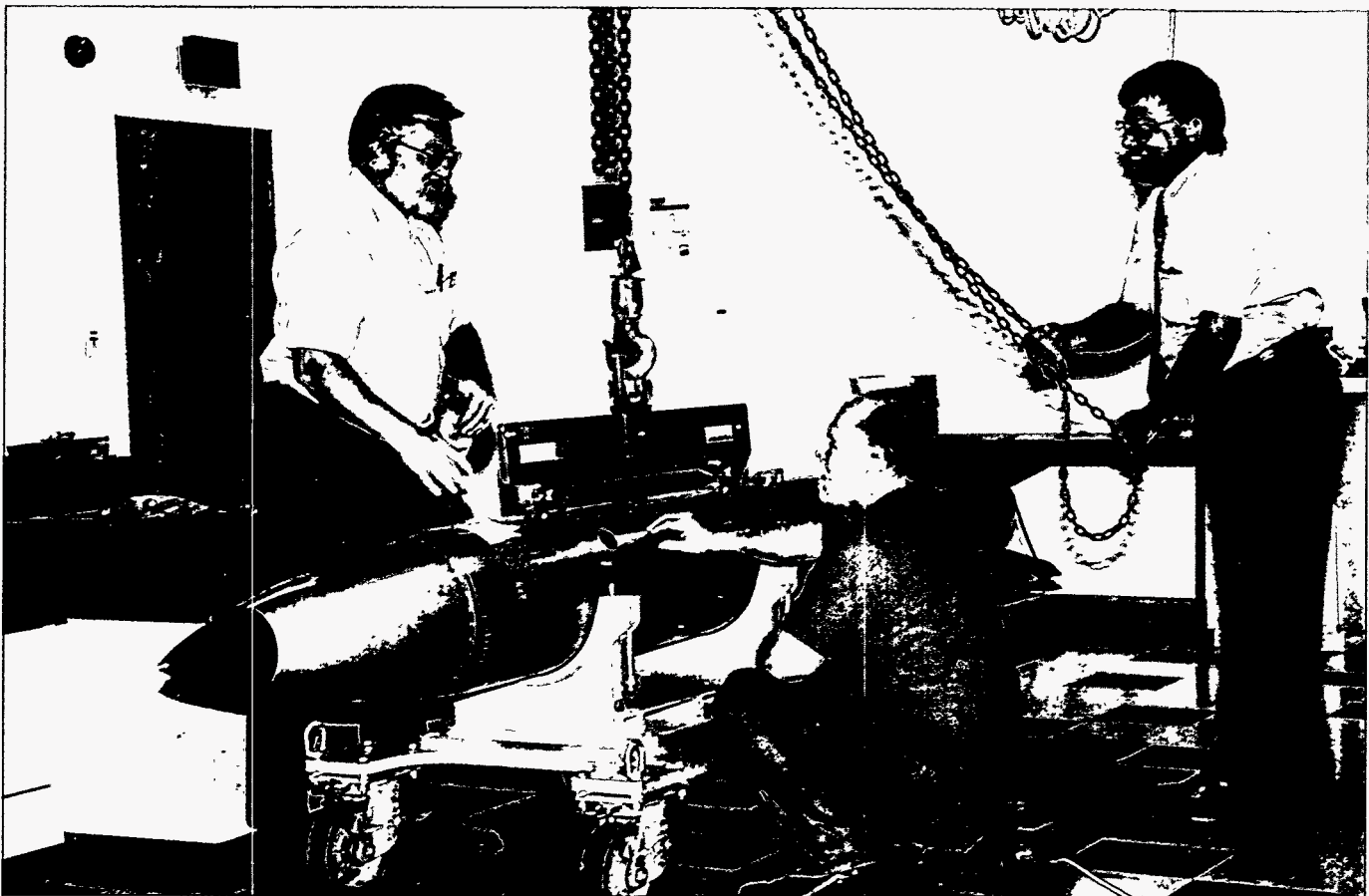

Ray Macallister, Ralph Carr, and Mike Rhoads prepare a B61 bomb training unit for a retrofit order evaluation. A new safety device (a trajectory-sensing signal generator) will be incorporated in the B61 stockpile by a field retrofit starting in 1995.

---

## **Special Projects (GB010304)**

### **Weapon Protection Projects**

Special weapon protection projects at Sandia develop security system concepts and applications to ensure nuclear weapon security and survivability in all phases of the life cycle. Near-term changes in the North Atlantic Treaty Organization's nonstrategic forces may result in the long-term deactivation of some weapon storage and security system (WS3) installations. A test project was initiated in Germany to determine how WS3 vaults react to long-term inactivity and to develop technical orders and recommend improved components to preserve their function and security.

DOE sites have traditionally used standard or slightly modified trucks or trailers for on-site weapon transportation because transport vehicles offering effective security systems have not been available. Intrasite shipments have been protected by large numbers of forces. An intrasite secure transport vehicle prototype was developed with a hardened cab and cargo compartment, access delay system, and vehicle immobilization system. The prototype is being tested and evaluated at several DOE sites.

### **DOE/DoD Munitions Technology Development Program**

The Joint DOE/DoD Munitions Technology Development Program authorized by a 1985 DOE/DoD memorandum of understanding is a jointly funded research and development program to develop innovative warhead, explosive, and fuze technologies and improve munitions technology for DoD service missions and the DOE nuclear weapons mission. Technology coordination groups and a technical advisory committee representing both DOE and DoD develop the program plans for each technical area, evaluate new proposals, and conduct technical reviews. In addition to the direct benefit to the nuclear weapons program, DOE Defense Programs benefits from the fact that DoD shares costs associated with maintaining core competencies for the nuclear weapons program. Current projects are under way in energetic materials, guidance and control, smart mines, countermines, and systems studies.

### **Cooperative Projects with the Former Soviet Union**

Cooperation with Russia and other independent states of the former Soviet Union has been encouraged by US policy. Sandia is supporting the safe and secure dismantlement of Russian nuclear weapons and projects for nonproliferation of weapons of mass destruction.

Collaboration with Russian weapons institutes and other entities in the former Soviet Union will obtain unique technologies for our programs and technology transfer. This is consistent with the national goal of providing weapon scientists and engineers of the former

Soviet Union with opportunities to redirect their talents to peaceful activities. Collaborations have been initiated in environmental sciences, computational sciences, pulsed power, space power systems testing and development, specialty metals research and development, shock-wave physics research and testing, materials sciences, and surety technology. We are also exploring collaborations in research, development, and testing of reactor-driven lasers, nuclear propulsion, and nuclear power safety techniques and technologies.

Most of these collaborations have been initiated since the breakup of the former Soviet Union, when new US policies encouraged cooperation with the newly independent states to support democracy and shift their focus from the military to the civilian economy. As we continue our interactions with entities in the former Soviet Union, we will identify new areas of joint interest in science and technology, and our collaborative efforts to exploit these new areas for mutual benefit will grow.

### **Transportation Surety**

DOE's Transportation Safeguards Division is responsible for the safe secure transport of all DOE-owned nuclear weapons and nuclear-weapon-related special nuclear material within the continental United States. As the original design agency for much of the equipment currently in service, Sandia provides the Transportation Safeguards Division with day-to-day operational engineering support for most major elements of the system including safe secure trailers, armored tractors, the mobile communications system, and the secure communications command/control center. Sandia is also responsible for design, prototyping, fabrication, testing, validation, and subsequent implementation of all upgrades associated with these subsystems. In addition, we provide the Transportation Safeguards Division with support for long-range planning, security analysis, probabilistic risk assessment, fleet maintenance, and small-quantity production runs.

Sandia is designing, developing, and prototyping a next-generation transporter called the SafeGuards Transporter. This effort will incorporate modern safety and security technologies into a new design that will ultimately replace the twenty-year-old safe secure trailer. The SafeGuards Transporter will incorporate improvements identified in recent risk assessments and tests in support of a full transportation safety analysis. However, the transporter will be only one part of a much-needed comprehensive systems modernization that should address all aspects of the system, including operations and procedures.

### **Accident Response Readiness**

Sandia provides technical support to DOE for its mission of developing and maintaining readiness to

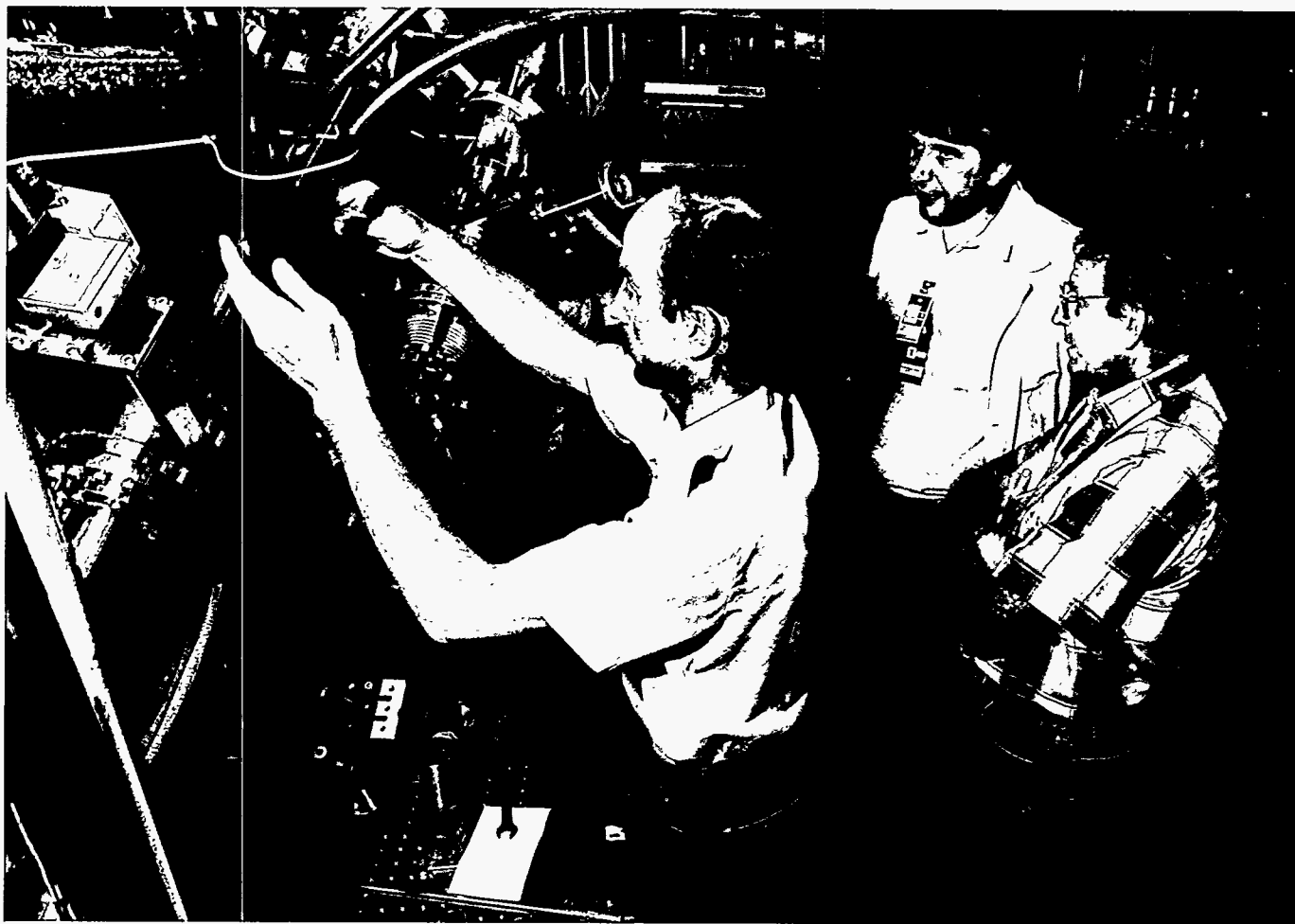

Russian scientists are shown working with Sandian Johann Seamen on a collaborative project that utilizes the Saturn accelerator to produce high x-radiation fields. The three men are working on a line-of-sight diagnostic tube underneath the accelerator.

respond to accidents involving nuclear weapons. Sandia participates in the readiness mission of the DOE Accident Response Group. In the event of an accident, Sandia supplies experts in nuclear weapons, nuclear weapons safety, and health physics, all specially trained to support field efforts for the safe recovery of damaged nuclear weapons. Sandia also provides specialty equipment needed.

In supporting the Accident Response Group, Sandia develops training materials, provides training, develops field equipment for use in weapon recovery, provides systems program planning, plans and implements field exercises, and provides nuclear safety evaluation of specialized equipment and procedures.

We are developing systems using proven modern methodologies and technologies to provide greater operational flexibility, safety, training, and exercises that are comprehensive and cost-efficient. One near-term

example is the portable integrated video system, which provides two-way video camera viewing and recording from a command post up to four kilometers away. Longer-term activity will incorporate this technology into an integrated, interactive multimedia training system. This would allow visual simulation of weapon accident exercise scenarios that incorporate multiple recovery activities and allow exercise simulation training for all personnel. A new system will improve DOE's ability to package a damaged nuclear weapon for shipment to a final disposal site. We have an integrated project under way utilizing generic accident-resistant packaging and funding from the Accident Response Group and United Kingdom Atomic Weapons Establishment to optimize damaged weapon packaging capability. In addition, remotely controlled robotics technology is being adapted to reduce recovery operations hazards to personnel.

### ***Consolidation of Tritium Activities***

To alleviate concerns over local environmental issues and reduce long-term cost to the nuclear weapons program, we will continue to support the centralization of tritium-related research and development at other DOE facilities by decommissioning the Tritium Research Laboratory at Sandia/California and moving it from the present low hazard (Category III) nonreactor status to a nonnuclear status. This work includes maintaining the DOE Defense Programs mission capability, reducing the accountable tritium to zero, relocating active experiments to other DOE facilities, reallocating excess equipment, and planning and documenting all cleanup and transition activities. Normal operations will be maintained until the tritium mission is ended by DOE.

### ***Propellants, Explosives, and Pyrotechnics Evaluation and Reapplication Project***

The propellants, explosives, and pyrotechnics evaluation and reapplication (PEPER) task force was commissioned in January 1993 to bring Sandia into full compliance with DOE explosive safety requirements. The PEPER task force is implementing a Sandia-wide process to reduce our propellant, explosive, and pyrotechnic inventory to that required for programmatic needs and to assure the stability of the remaining inventory. Tasks include counting the inventory, assessing its stability, and facilitating disposal of material. All energetic materials under Sandia control (at Sandia, DOE, DoD, or commercial facilities) are included.

### ***Education Outreach***

The education activities supported in this budget category are described in the section for the Office of Science Education and Technical Information.

### ***Nuclear Emergency Search Team (GB010305)***

The Sandia Nuclear Emergency Search Team has historically focused on mitigating radioactive aerosols generated during violent disablement of improvised nuclear devices, predicting the consequences of such dispersals, devising methods of rendering improvised nuclear devices safe, and developing field-portable methods of determining the type of explosive in such a device.

Sandia is responsible for developing a program to provide training for all people involved in a Nuclear Emergency Search Team field response and for assuring that these people are knowledgeable about their responsibilities. A considerable portion of the past year has been used to begin this training program. Sandia was recently asked to lead the Nuclear Emergency Search Team full-field exercise in the fall of 1994 and to participate in planning subsequent exercises.

World events have exacerbated nuclear terrorism concerns. Awareness is increasing of the role that the Nuclear Emergency Search Team would play in overseas deployments. The budgetary requirements package for future years identifies a need for additional funding and expansion of the Nuclear Emergency Search Team effort.

### ***Test and Experimental Capabilities (GB0104)***

Sandia is the lead DOE laboratory for aboveground test simulation of radiation effects and certification of nuclear weapons to operate reliably in hostile radiation environments. We integrate experimentation and computational simulation efforts in support of radiation effects testing, radiation transport, diagnostics, analysis, and computation development to certify that electronic components will operate in hostile radiation environments.

As a consequence of recent budget cuts, support of core capabilities at the Nevada Test Site has been reduced. The reduced capabilities maintain nuclear testing safeguards consistent with DOE directives and continuation of the testing moratorium. Sandia will support Los Alamos and Lawrence Livermore national laboratories' hydrodynamic experiments and will maintain the capability to resume underground nuclear testing in eighteen months if directed.

Sandia is consciously shifting resources from underground nuclear testing to aboveground simulation. With the permanent cessation of underground testing in October 1996, Sandia's aboveground capability will ensure that the remaining stockpile is survivable. Therefore, every effort is being made to enhance the aboveground testing program, maintain our radiation effects science expertise, and collaborate with the Defense Nuclear Agency, the key agency within DoD that has similar mission requirements.

### ***Test Simulation and Aboveground Experiments***

Sandia's radiation effects testing program certifies that weapon components and subsystems will function reliably during hostile nuclear bursts in the specified stockpile-to-target sequence. These bursts include nuclear radiation outputs of x-rays, gamma-rays, and neutrons. Formerly, we employed a combination of aboveground testing, analysis, and underground testing for development and reliability certification.

A recent presidential directive extends the moratorium on underground nuclear testing. However, stockpile improvement programs (including upgrades in safety and reliability) will need certification of operability in hostile radiation environments. Moreover, it is extremely important that single-mode failures be avoided in the much smaller stockpile of the future.

Sandia's radiation facilities and effects expertise are recognized national resources for high-fidelity simulation



and understanding of nuclear weapon effects. Our aboveground experimental facilities (the Saturn and HERMES III accelerators and the SPR-III research reactor) are primarily used to simulate x-ray, gamma-ray, and neutron environments. The pulsed-power Saturn and HERMES III machines generate low- or high-voltage bremsstrahlung radiation, electron beams, or radiation from plasma sources and are used to simulate the x-ray and gamma-ray portion of conventional nuclear weapons. We typically test strategic reentry vehicles, missile and satellite components and subsystems, or tactical subsystems and systems in these simulated x-ray and gamma-ray environments.

The SPR-III fast pulse reactor is an unmoderated cylindrical assembly of fully enriched uranium alloyed with ten percent molybdenum. This aboveground experimental facility is used to certify the hardness of the stockpile to radiation effects.

We are not yet in a position to certify future or reconfigured strategic systems without underground tests. In 1991 we began a program in cooperation with the Defense Nuclear Agency to assess our ability to correlate aboveground and underground test results for electronic systems and extrapolate them to realistic hostile environments. This work will develop a test protocol for certifying nuclear survivability without underground testing.

Consequently, we will need to improve our aboveground testing capabilities (including rise time, pulse width, and fluence improvements in Saturn and HERMES III) and build a new x-ray simulation facility for testing that now can be conducted only underground. This new Jupiter facility will be a cold and warm x-ray source that will permit aboveground testing of materials and structures currently possible only with underground testing.

The Jupiter x-ray simulation facility will generate 20 megajoules of x-rays using a plasma radiation source. The plasma radiation source will be controlled to provide excellent testing capability at 8 kiloelectronvolts and below, and good capability at 14 kiloelectronvolts. The Jupiter facility will also offer weapons physics research applications and x-ray physics testing with 5 to 20 megajoules of thermal x-rays and will provide the next developmental step for an x-ray source capable of testing a large system in an x-ray environment. Materials survivability in hostile x-ray environments has only been tested under ground. Jupiter is a key to future testing of materials in x-ray environments under a test moratorium.

Even with improvements in our aboveground testing capabilities, testing for thermonuclear weapon effects in full reentry vehicle or reentry body structures could not be accomplished without underground testing. Nevertheless, by enhancing our aboveground testing capabilities and constructing the Jupiter pulsed power facility, we think we can certify weapon subsystems without underground testing.

### *Nevada Test Site Core Capabilities*

Sandia maintains underground test capabilities for vertical weapons safety and reliability tests and DoD-sponsored weapon-effects reliability tests. Because the moratorium on nuclear testing will continue indefinitely, these core capabilities are being maintained to support the nuclear testing safeguards sanctioned by Congress. These safeguards require that DOE maintain the scientific resources and technical capabilities to resume underground tests if directed. To enhance this effort, Sandia has joined with Lawrence Livermore, Los Alamos, and the Defense Nuclear Agency to form the joint test organization at the Nevada Test Site. The members of the joint test organization share resources and focus on planning, managing, and executing a cooperative program at the Nevada Test Site. The intent is to maintain a state of readiness consistent with nuclear testing safeguard requirements to support hydrodynamic experiments.

The principal Sandia core capability supporting Nevada Test Site testing is the arming and firing systems used in every test. These safety or reliability test systems are completely provided and fielded by Sandia. Additionally, the arming and firing system for DoD-sponsored reliability tests, including integration with the closure systems and experiment firing and timing requirements, is also provided and fielded by Sandia. In each case a detailed inventory of the required electronics, power supplies, supporting hardware, and limited-life components is maintained to ensure that all planned tests are fully supported and can be executed without delay.

The core capability to design, fabricate, and field closures for DoD-sponsored tests is now jointly supported by the Defense Nuclear Agency and Sandia. This capability is critical to protect the effects experiments on a test and ensure that containment is successful.

The core capability for ground motion and seismic measurements on all DOE and Defense Nuclear Agency tests is maintained by Sandia. Additionally, the Defense Nuclear Agency and Sandia jointly support containment diagnostics developed and fielded by Sandia for weapon effects tests involving horizontal line-of-sight pipe flow measurements, stemming response, fast closure performance, ground shock, air blast, cratering, and free-field ground shock measurements.

### *Laboratory Underground Test Core Capability*

The instrumentation group rounds out the core capabilities critical for underground tests at the Nevada Test Site. The Sandia data acquisition system and supporting personnel are key in ensuring the success of any Defense Nuclear Agency-sponsored effects test. We are implementing a nuclear effects safeguards program to make repairs and improvements to enhance quality, maximize efficiency, and improve system performance.

### **Stockpile Stewardship Support**

Aboveground and underground testing is used in the developmental phases of every nuclear weapons system in the stockpile to build in hardness and survivability. Once the systems are in the stockpile, they are subject to a detailed surveillance program that has identified a number of new problems each year that must be corrected. When the corrective action requires replacement of a component within a system, that component is certified to the integrated hardness level required for the system, primarily using Sandia's aboveground capabilities.

With a significantly smaller stockpile, the survivability of each system will be even more critical. Therefore, maintenance actions will depend on aboveground testing at Sandia.

Additionally, a program being considered requires periodic verification of the certified radiation hardness of stockpiled systems. Such a program was sponsored for earlier systems (the Mark 3 and Mark 4), ensuring that they would operate as required. Knowing that the stockpile life span of a weapon system will be much greater than the current twenty-year average places additional responsibility on surveillance to ensure that no surprises develop.

### **Technology Transfer Initiative (GB0106)**

Technology transfer is a congressionally mandated mission of DOE national laboratories. The Defense Programs Technology Transfer Initiative carries out this mandate by sponsoring the transfer of technologies,

skills, and know-how between the DOE nuclear weapons complex and the private sector. The goal is to make selected nonnuclear technologies available to US private industries in a manner that will help strengthen the core competencies of DOE Defense Programs and enhance the competitiveness of US industry. This initiative supports Sandia's participation in cooperative research and development agreements with individual companies and other cost-shared collaborative projects involving entire industries. There are currently six major areas of focus.

### **Advanced Manufacturing and Precision Engineering**

Sandia works closely with DOE production plants during and after weapon development to ensure that designs will be manufactured cost-effectively and that products will meet design intent.

As a result of this work, Sandia has developed manufacturing capabilities to respond to a variety of national needs. Cooperative research and development agreements in the area of advanced manufacturing and precision engineering focus on manufacturing systems design and development, manufacturing processes, computer-integrated manufacturing, machine tool design, precision measurements, precision engineering, and instrumentation and sensing. Critical industries include aerospace, machine tools and machine tool utilization, and lithography and lithographic equipment for both semiconductor and flat-panel display manufacturing.

Several companies are already working with Sandia on specific projects in these areas.

#### **Technology Transfer Initiative Participants in Advanced Manufacturing and Precision Engineering**

<u>Company</u>	<u>Technology</u>
Aluminum Company of America	Precision aluminum forming
Amax Plating, Inc.	Electroplating process control
AMTEX Sensors	Demand-activated manufacturing architecture
Beckman Instruments, Inc.	Advanced analytical instrumentation
Corning, Inc.	Flexible manufacturing and molten glass products
Cray Research	Environmentally safe manufacturing of printed wiring boards
General Motors	Simulation and analysis of robotic assembly devices and fixtures
Goodyear Tire & Rubber Company	Advanced mechanics tools for engineering processing analysis
Kaehr Plating & Metal Finishing	Electroplating process control
NCMS	Heat treatment distortion
Pratt & Whitney	Automated surface and edge finishing
Precision Fabrics Group, Inc.	Lightweight safety restraint
Rocketdyne	Intelligent processes for welding, machining, and assembly

### **High-Performance Computing and Applications**

Sandia's computational science research is aimed at developing massively parallel computing methods and a software infrastructure for parallel computing. Advanced computing technologies will play a critical role in the future of US national defense and economic security. Cooperative research and development agreements in this area focus on high-performance computing and networking, simulation and modeling, pattern recognition and image analysis, and high-density data storage and transmission.

### **Energy and Environment**

Numerous technologies are mutually beneficial to DOE Defense Programs and the national energy strategy. Cooperative research and development agreements in this area sponsored by the Defense Programs Technology Transfer Initiative involve environmentally conscious manufacturing technologies that minimize the generation of wastes at the source, systems integration technologies (including life-cycle design, materials recycling, and value-impact assessments), environmental characterizations and monitoring instrumentation, nonintrusive diagnostics and controls, energy conservation, and emission control technologies.

### **Health Care Technologies**

Sandia weapons technologies are being used to address rising US health care costs and their negative effect on US competitiveness. These technologies contribute to reducing health care costs and improving health care delivery. The dual-benefit technologies include biosensors, instrumentation for earlier diagnosis, biomaterials, noninvasive diagnostics, laser therapy, robot-assisted procedures, signal processing of medical images, medical information systems, computational biology, and minimally invasive therapies.

### **Materials and Processes for Manufacturing**

The requirement for special materials and fabrication processes for nuclear weapons has produced a need for continuous advancement in this core competency. Cooperative research and development agreements in the area of materials and processes for manufacturing are developing new materials and material processing techniques and are characterizing and certifying advanced materials. Some projects involve the development of materials and processes used in the manufacture of aircraft engines and the application of DOE Defense Programs joining technology to aerospace and aircraft industry needs.

#### **Technology Transfer Initiative Participants in High-Performance Computing and Applications**

<u>Company</u>	<u>Technology</u>
Amoco Oil Company	Simulation of residual oil hydroprocess units
AT&T	Experimental high-speed network test bed
BIOSYM Technologies	Mathematical libraries for modeling materials
BIOSYM Technologies	Molecular design of polymer alloys
Citibank, N. A.	Advanced information technologies
Cray Research	Massively parallel electron structure
Fluid Dynamics International	Sandia mesh-generation computer software
Ford Motor Company	Sandia mesh-generation computer software
General Motors	Computer-aided structural system identification
Hewlett-Packard	Properties of visible light-emitting diodes
IBM	Numerical modeling
IBM	Hierarchical high-performance storage system test bed
Intel	Parallel computing C++ mathematical libraries
IRT Corporation	Pattern recognition applied to personnel scanner for contraband
MacNeal-Schwendler	Sandia mesh-generation computer software
nCUBE Corporation	Software tools for scalable massively parallel databases
Oceania Health Care Systems	Computerized medical patient records
Oracle Corporation	Software tools for scalable massively parallel databases
PDA Engineering	Sandia mesh-generation computer software
Photonics Imaging	Plasma flat-panel video monitors
Weidlinger Corporation	High-performance computing

### Microelectronics and Photonics

Microelectronics is critical to development of components for nuclear weapons. Therefore, Sandia researches the fundamental electrical, mechanical, magnetic, and structural properties of electronic materials and explores new techniques for fabricating and selectively altering thin-film layers, surfaces, and surface regions. This will aid in controlling the properties of microdevices. We also conduct research and development in compound semiconductors such as gallium arsenide and indium

arsenide, materials that will play a greater role in future weapon systems for improved safety and use control.

A competitive domestic microelectronics industry is vital to US national security and to the US economy in the broadest sense. A major concern is the length of time required to translate research developments into manufacturing advantages. Sandia is involved in numerous cooperative research and development agreements with industry to speed up this process.

#### Technology Transfer Initiative Participants in Energy and Environment

Company	Technology
Aculight Corporation	Multispectral ultraviolet fluorescence lidar system
Cummins Engine Company	Control of nitrogen oxide emissions
Cummins Engine Company	Pulsed plasma processing of diesel engine exhaust
ECO Air Corporation	Environmental automobile air conditioner
Electronics Consortium	No-clean soldering processes
General Motors	Reduction of nitrogen oxide emissions
General Motors	Engine fluid condition monitors
Magnetic Separation Systems	Sorting postconsumer waste
Mission Research Corporation	Multispectral ultraviolet fluorescence lidar system
Mobil Research and Development	Large-scale modeling
nCUBE Corporation	Large-scale modeling
RIMtech	Borehole radar imaging technology

#### Technology Transfer Initiative Participants in Health Care Technologies

Company	Technology
ARIA Corporation	High-power laser diode systems
Wellman Laboratories	Laser burn diagnostic and debridement system
MicroDexterity Systems, Inc.	Telemicro-robotic applications

▲

**Technology Transfer Initiative Participants in  
Materials and Processes for Manufacturing**

Company	Technology
Allied-Signal, Inc.	Joining Si <sub>3</sub> N <sub>4</sub> for advanced turbomachinery applications
Aluminum Company of America	Processing of aluminum alloys
Amoco Chemical Company	Polymeric nonlinear optical materials and devices
Babcock & Wilcox	Advanced materials processing of welded assemblies
Carpenter Technology	Advanced materials for aircraft engine applications
Dow Chemical Company	Processing with chlorinated polyethylene
Dow Corning Corporation	Micro-engineered materials
Dupont	Diamond reinforced composites
Edison Welding Institute	Arc welding quality control
GE Superabrasives	Synthetic diamond substrates
General Motors	High-temperature electronics
General Motors	Intelligent systems for induction hardening processes
General Motors	Lightweight materials for automotive applications
General Motors	Thermal spray technology for cylinder bore coatings
GeoCenters	Intelligent sensors for composite materials manufacturing
Goodyear Tire & Rubber Company	Materials for improved tire technology
National Center for Manufacturing Sciences	Wiring board interconnect systems
Norton Company	Large area polycrystalline diamond substrates
Pratt & Whitney	Intelligent processing of thin-section welded assemblies
Pratt & Whitney	Novel laser coating and joining technology
Pratt & Whitney	Welding and processing of an advanced titanium alloy
TN Technologies	Mercuric iodide sensor technology
Xsirius Inc.	Mercuric iodide sensor technology

**Cost-Shared Collaborations**

In addition to cooperative research and development agreements involving individual companies, Sandia's work for the Defense Programs Technology Transfer Initiative also supports cost-shared collaborations that involve large segments of specific industries or consortia. Three representative collaborations are discussed below.

**Specialty Metals Processing Consortium**

The Specialty Metals Processing Consortium conducts research that will improve the technology base for melting processes used in the specialty metals industry. This research will assist the US specialty metals industry and strengthen the nation's industrial base. The program will support Sandia's participation in a joint, five-year program with industry and universities. An interdisciplinary team of Sandia experts, industrial interns, and students will study generic problems of melting processes such as vacuum-arc remelting, electrosag remelting, and electron-beam melting. Developments will be evaluated with industrial experiments at consortium member plants.

**FASTCAST™**

FASTCAST™ is a Sandia program for rapid production of investment cast prototype hardware. The program is structured to support Sandia organizations that design and fabricate hardware for internal and external customers. The technical goal of the program is to integrate experimental and computational technologies into the investment casting process. The effort should reduce the time required to produce prototypical castings from fourteen weeks to possibly three weeks. The work will develop the experimental rules to design gating systems, integrate those rules into a database, verify computer models to predict casting processes, and develop a database of material properties related to investment casting.

Sandia capabilities in investment casting include an airfoil-quality ceramics laboratory for mold preparation, a rapid prototyping laboratory for wax pattern production, a vacuum foundry, extensive diagnostic and computational capabilities, and state-of-the-art materials research facilities. Over the past three years, Sandia has integrated these technologies into a comprehensive base to support investment casting process research.

Technology Transfer Initiative Participants in  
Microelectronics and Photonics

Company	Technology
Advanced Micro Devices, Inc.	New integrated circuit manufacturing technologies
Air Products and Chemicals, Inc.	Advanced diffusion barrier technology
Air Products and Chemicals, Inc.	Chemical vapor deposition
Alpha Industries	Manufacturing of monolithic microwave memories
Analog Devices	Microelectronics quality reliability
AT&T	Noncontact atomic-level interface force microscope
AT&T	Gold-sulfite electroplating
AT&T	Projection x-ray lithography using a laser plasma source
Bristol Myers Squibb	Massively parallel simulation
Coloray Display Corporation	Field emitter array using SXP lithography
Coloray Display Corporation	Gated field emitter arrays
Conductus	Confocal resonator imaging systems for surface assembly
Cray Research	Massively parallel simulation
Digital Instruments	Noncontact atomic-level interface force microscope
Dupont	Massively parallel simulation
EMCORE Corporation	High-throughput rotating-disk reactors
GCA Tropel	Soft x-ray projection imaging optics
Hewlett-Packard	Advanced manufacturing techniques for optoelectronics
Hewlett-Packard	Field emission source with phosphor screen
Hewlett-Packard	Wafer-level accelerated reliability testing software
Intel	Advanced diffusion barrier technology
J. W. Harley	Fiber-optic hydrogen sensing
LAM Research Corporation	Advanced intermetal dielectric technology
LSI Logic	Failure analysis for integrated circuits
Micro. & Computer Technology	Field-emission flat-panel display
Motorola	Compound semiconductor heterostructures and materials
Motorola	Advanced precursors and chemistries
Motorola	Thin-film diamond growth
Motorola	Organic luminescence
Motorola	Advanced SiGeC materials
Olin-Hunt Specialty Products, Inc.	Evaluation of electromigration tolerance in CCVD aluminum
Philips Semiconductor Company	Investigation assessment and benchmarking
Photonics Imaging	Plasma panel materials
Radiant Technologies	Ferroelectric read/write optical disc
Radiant Technologies	Nondestructive readout nonvolatile memories
Schlumberger Technologies	Failure analysis system for integrated circuits
Schumacher, Inc.	Chemical vapor deposition of copper
Schumacher, Inc.	Advanced diffusion barrier technology
SEMATECH	Contamination-free semiconductor manufacturing
Texas Instruments	Semiconductor plasma processing
Thunder Scientific	Fabrication of porous silicon humidity sensors
University of New Mexico	Noncontact atomic level interface force microscope
University of New Mexico	Fabrication of microreactors in silicon
Watkins-Johnson	Chemical vapor deposition of copper

### *Semiconductor Equipment Technology Center*

Sandia's semiconductor equipment technology center applies research in reliability modeling and process technology to the development of new integrated circuit production equipment by US manufacturers. This microelectronics technology and benchmarking project will strengthen the infrastructure of the semiconductor manufacturing industry. The work is in collaboration with SEMATECH, a consortium involving the federal government and major US semiconductor manufacturers.

### *Inertial Confinement Fusion (GB02)*

DOE funding has provided the principal pulsed-power technology and facilities for our exploration of inertial fusion as a future x-ray source for nuclear weapon effects testing, weapon physics studies (in collaboration with Los Alamos and Lawrence Livermore national laboratories), and fusion power production.

The low cost and high efficiency of the pulsed-power approach to inertial fusion have permitted unique megajoule-class facilities to be constructed and used for inertial confinement fusion research. As a product of the flexibility of pulsed-power technology, the Particle Beam Fusion Accelerator I and Proto II facilities have fulfilled their original research purposes and have been converted into new machines, Saturn and Proto II—major national facilities for nuclear weapon effects simulation, x-ray atomic physics research, radiation flow research, and survivability testing.

Pulsed power is a core competency of Sandia. Applications contribute to national security today as we develop the pulsed-power-driven light-ion approach to inertial confinement fusion for even greater utility. The lower cost per unit of energy of light ion beams (compared to lasers) offers potential savings for the laboratory microfusion facility, a future aboveground testing facility that will provide a thermonuclear yield exceeding 500 million joules. The fundamentally different x-ray production mechanism with light ions provides prudent risk management of potentially severe laser-plasma interactions in the hohlraum for the laser approach to inertial confinement fusion.

Our responsibilities include technical direction of all DOE-funded activities for light-ion inertial confinement fusion. Sandia directs light-ion efforts in accelerator development, intense ion-beam generation and transport, beam focusing, beam-target interaction, radiation production and symmetrization, and target hydrodynamics.

Sandia's Particle Beam Fusion Accelerator II, the world's most powerful particle accelerator, is being used for ion-beam-driven target experiments. The Sandia accelerator and beam research experiment enables us to develop beam generation and transport techniques in the geometry needed for high yield. This work is determining

the feasibility and cost-effectiveness of the light-ion approach for the laboratory microfusion facility.

Recent experiments give us confidence that a 500-megajoule laboratory source of thermonuclear radiation may be obtainable through inertial confinement fusion if progress in the major areas listed below can be further developed and integrated:

- Intense proton-beam generation and focusing in the Particle Beam Fusion Accelerator II were advanced in FY 1989 with the achievement of a power density of 5 trillion watts per square centimeter. In FY 1993, the lithium beam power intensity was improved from 0.1 to 1.5 trillion watts per square centimeter.
- The 5-trillion-watts-per-square-centimeter proton beam intensity allowed a hohlraum temperature of 35 electron volts to be achieved. The 1.5-trillion-watts-per-square-centimeter lithium beam intensity drove a radiation-dominated hohlraum to 58 electron volts. Our next major milestone (FY 1995) is to measure 100 electron volts in a hohlraum beam driven by a lithium beam. This temperature will require a lithium beam intensity of about 5 trillion watts per square centimeter.
- Ultimately, high-yield experiments will require that the pulsed power components, the beam generation apparatus, and the target chamber wall be separated from the target itself by several meters. Propagating ion beams over these distances will require improvement in beam divergence from 20 milliradians to as low as 6 milliradians and demonstration of stable transport in low pressure gases.

The near-term goal of the program is to establish the feasibility of inertial confinement fusion using ion beams produced directly from a pulsed-power generator. This goal will be approached through target experiments in Sandia's Particle Beam Fusion Accelerator II, the Sandia accelerator and beam research experiment, Hermes III, and supporting experiments at collaborating institutions—Cornell University and the Naval Research Laboratory.

In the interim, we will continue to collaborate with other DOE laboratories to assess the potential of the national ignition facility for ignition and gain in the laboratory with a glass-laser driver. Sandia's contributions to the conceptual design include pulsed-power conditioning, design of the target chamber, development and integration of radiation-hardened target diagnostics, and work on internally pulse-shaped targets for ignition and gain.

The long-term goal of the program is to provide the driver for a laboratory microfusion facility for the Office of Military Application in the first decade of the next

---

century. Plans for technology development of a laboratory microfusion facility using the Sandia accelerator and beam research experiment and Hermes III have been presented to the inertial confinement fusion advisory committee. Ultimately, the low cost and high efficiency of the pulsed-power approach may provide fusion power generation for electricity.

### ***Stockpile Support (GB03)***

Stockpile support at Sandia focuses on understanding, maintaining, updating, and improving the safety, security, performance, and reliability of the nuclear weapon stockpile. Our efforts are divided into three major, interrelated thrusts: maintaining stewardship of the stockpile; preserving, modernizing, and reconfiguring design and manufacturing capabilities as appropriate; and assisting DOE with several change initiatives, including adoption of modern quality practices, dismantlement, privatization of component manufacturing, environmentally conscious manufacturing, and migration toward the reconfigured complex. Success across all fronts requires a sound investment strategy that preserves the foundation of nuclear design and manufacturing capability.

### ***Stockpile Stewardship***

#### ***Weapons System Engineering***

The US nuclear weapons stockpile continues to evolve in response to dramatic changes in global security. New weapons are not expected to be introduced into the stockpile in the near future and stockpiled weapons are being reduced or eliminated, which will result in a significantly smaller stockpile with greater surety, reliability, and longevity.

The public's expectations for safety, security, survivability, reliability, and environmental protection in all phases of nuclear weapon stockpile management continue to evolve to higher levels. Supporting this evolving stockpile in an era of declining budgetary resources demands that Sandia be innovative and efficient.

Stockpile support involves two broad activities: maintenance and improvement of weapons that will remain in the stockpile; dismantlement and disposal of weapons in excess of national nuclear deterrent requirements.

Weapons will probably remain in the stockpile well beyond their original design lives. Weapon delivery systems will evolve in response to technology advancement, budgetary constraints, obsolescence, or treaty actions. These changes will necessitate continuous assessment of the surety, military effectiveness, delivery system compatibility, and longevity of the stockpile, which will be accompanied by programs that evaluate and implement value-adding improvements.

Recent reductions and changes in our strategic nuclear forces have dictated changes to the intercontinental ballistic missile force structure that may extend to 2003. By then, the force will be configured entirely with Minuteman III missiles loaded with single warheads. During the interim, several warheads need to be qualified for the new environments associated with single reentry vehicle loads on the Minuteman III missile.

Similar restructuring is scheduled for submarine-launched ballistic missiles, air-delivered strategic weapons, forward-deployed weapons, and naval fleet weapons. All this redeployment will require alterations to reduce maintenance and special initiatives to provide an adequate quantity of storage containers as weapons wait for redeployment or dismantlement.

Concurrently, some limited-life components will be replaced to extend the interval between changes. Product improvements to maintain surety, reliability, and longevity will be the principal activity for the foreseeable future, as exemplified by the current replacement of radars and trajectory-sensing signal devices in several nuclear bombs.

Support of the stockpile will also have to be compatible with the changing infrastructure of the military services. Base closures and consolidations and the overall reduction of service personnel will have a significant impact on the services' capability to maintain the stockpile and implement improvements. Our maintenance and improvement programs must remain compatible with the services' capabilities.

Weapons in excess of national needs for nuclear deterrence require similar oversight to maximize safety and surety from the time they are designated for retirement until their constituent components are disposed of. The limited capacity to dismantle nuclear weapons means that some weapons with older, limited surety features will remain assembled for many years. Safe storage and transportation of these weapons is one of our primary concerns. Limited understanding of the materials in some of the older weapons will limit our capability to dispose of the components that make up those weapons. It is our responsibility to provide engineering expertise for DOE to use in overcoming these limitations.

### ***Military Liaison***

In the area of military liaison, the surety and effectiveness of the nuclear stockpile remain crucial to US security. Sandia's stockpile stewardship has ensured this surety and effectiveness for more than forty years. However, as a significant portion of the stockpile is retired and the remaining portion is restructured, new challenges and the activities to address them are increasing rapidly.

Serving as the DOE focal point for integrating military operational needs and surety requirements is part of Sandia's mission. In maintaining stockpile integrity, we



---

provide a broad range of support services to ensure that the stockpile remains safe, secure, and reliable. Sandia is the recognized leader of operations, maintenance, and logistics for nuclear weapons from concept through dismantlement.

We provide stockpile support through classroom and field training in weapons handling for DOE, DoD, and laboratory personnel. Training classes are provided for DoD weapons instructors, operational staff, and maintenance technicians. Weapon refresher training is also provided to DOE and other DoD personnel. We maintain a staff of trained instructors and modern training facilities for this purpose.

Sandia writes and distributes more than two hundred technical manuals for DoD operational elements on how to use, maintain, inspect, and transport nuclear weapons. By using a new publication system that complies with the requirements of the DoD computer-aided acquisition and logistics support system, we will reduce costs while improving timeliness and quality of our technical publications. We also produce video tapes to aid instructors in weapon maintenance, special repair procedures, and permissive-action-link operations. Sandia's military liaison group represents DOE on the joint nuclear weapons publications system council.

New deployment postures require more attention to the stockpile. Limited-life components are now being exchanged in the field using new equipment and procedures that improve reliability and safety.

Sandia's stewardship reflects increased concern for the environment. Maintenance procedures have been revised to eliminate hazardous materials and better containers are being designed for transporting components that contain radioactive materials, making operations in the field as safe as possible for both personnel and the environment.

Activities must keep pace with the rapid changes taking place in the world—changes that will continue and redefine the old meaning of stewardship. Thus, Sandia will continue to meet its responsibility to the nation for the surety and effectiveness of the nuclear stockpile.

### *Independent Assessment of Nuclear Safety*

The first priority of the weapons program at Sandia is to ensure safety in the design, development, production, and military deployment of nuclear weapons. The highest levels of nuclear safety assurance are achieved by independent safety assessments conducted by experts in nuclear weapon design and nuclear safety disciplines. A goal is to provide increasingly comprehensive assessments of nuclear safety from system concept through warhead retirement.

We are committed to the concept that nuclear safety starts with features in the nuclear weapon that prevent unintended detonations. The independent assessment of

weapon safety evaluates and implements design safety and determines the quality of critical weapon components. This assessment supports development of new weapon design concepts and safety upgrades in the weapon stockpile. This requires unique test and evaluation programs to determine the response of components and systems to both normal and abnormal environments.

The variety of nuclear weapon systems and the environments for system operations complicate the nuclear safety assessment. Conditions include multiple weapon configurations and launch platforms, numerous locations, many procedures involving a wide variety of personnel and special equipment, and exposure to a myriad of energy sources. It is a challenge to identify and implement nuclear safety enhancements.

Given our responsibility for comprehensive safety assessment of nuclear weapons, we continue to take the initiative in joint DOE/DoD assessments. We will further develop methodologies for safety assessments of complex systems and will gather system-related data to support these assessments.

Sandia possesses unique experience in safety evaluations and in testing and analysis of weapon and system response in complex and abnormal environments. This experience will be augmented by an extensive nuclear safety test and evaluation program, the development of evaluation methodologies, and an expanding information base on nuclear safety technology. Information will continue to be integrated into a state-of-the-art, multimedia database. This information system is the basis for training personnel responsible for nuclear explosive safety and for supporting nuclear accident response activities and cooperative efforts with Russia and other countries of the former Soviet Union.

### *Quality Assessment and Engineering*

Sandia conducts quality evaluation and qualification of weapon designs, weapon hardware, associated software, controllers, field handling and test equipment, and joint test systems hardware and software during design and production, and after production has begun. We provide product acceptance and maintain records for Sandia-procured products. Our qualification evaluation information center maintains a database of the qualification history and lessons learned. We help develop quality plans, furnish support to suppliers, provide service to development groups, and conduct supplier surveys and audits. We also conduct process evaluation by characterizing the manufacturing processes and equipment, especially for process transfers and new suppliers. We qualify acceptance equipment, testers, gauges, and associated software. We conduct internal quality assessment based on our sponsor's quality criteria for production activities and research and development. We ensure that the product will meet the requirements of its

---

intended use and that acceptance equipment supports this goal.

Sandia also conducts weapon quality process activities and software quality development and evaluation. Quality is incorporated in weapon design and development via early involvement and team concepts. We continue to develop a software management program to ensure a consistent approach to the management of all software being acquired, developed, supported, and used.

We encourage organization-specific, results-oriented management plans that promote software improvement and incorporate quality assurance and quality control. We help guide project designers through software engineering processes to produce a quality product. In-house software engineering courses are offered and software guidelines are promulgated. We plan to establish software metrics for war-reserve embedded computer systems. Results will be integrated in the system and ultimately used to improve the software reliability of the stockpile.

### *Stockpile Surveillance*

Sandia's independent assessment program verifies that the reliability and safety of the nuclear weapons in the stockpile are at the levels required by DOE and DoD. The entire testing and evaluation program is formulated by a Sandia/DOE/DoD team.

Nuclear weapons are selected from the stockpile, returned to DOE's Pantex plant, denuclearized, instrumented, and tested. Some are subjected to environmental extremes in the Weapons Evaluation Test Facility at Pantex. Others are shipped to DoD sites, mated to their delivery systems, and flown in test flights. If problems are detected or failures occur, a team is formed to find the cause of the anomaly, assess its impact, and recommend resolution. A data bank of all system tests and problems is maintained to provide proof-of-system reliability, safety data, and a record for use in future designs.

Major changes to the stockpile surveillance program are being made to accommodate a smaller number of weapons and a declining budget. Handling, shipping, and disassembly costs will be reduced by coordinating the selection of weapons to be tested with weapons operations such as scheduled maintenance. Tests are being replanned to place more emphasis on aging effects caused by longer-than-expected lifetimes. Critical safety components are being examined due to higher standards of environmental safety and health.

More realistic test configurations are being generated to improve our ability to detect subtle problems in ultra-high-reliability systems. We are redesigning denuclearized test units for weapon evaluation laboratory testing of more than one type of weapon system. This will provide more flexibility during routine maintenance or breakdowns, and a more interchangeable, economical tester mix.

We are responding to increased personnel safety

requirements by performing test operations safety reviews with independent assessors and by replacing test equipment built to less stringent safety standards. The hydraulic-driven centrifuges at the weapons evaluation test facility are being converted to electrical systems.

Our objective is to support a highly reliable and extremely safe stockpile with a timely, cost-effective, well coordinated, and mutually beneficial stockpile evaluation program.

### *Manufacturing Capabilities*

#### *Engineering Information Support*

Our objective of supplying engineering information systems merges existing and anticipated stockpile support requirements with practical and cost-effective information technology. This mission is challenged by a reduced stockpile and very limited new build opportunities. Modernization of information systems, downsizing to more cost-effective platforms, and alignment with industrial, national, and international standards is essential.

The goal of this program is to establish a state-of-the-technology design and analysis capability built on standard hardware and software products. Conformance to industry standards will ensure that solutions adopted today will match the options of tomorrow. Time cycles and operational costs will be reduced.

Engineering information support strategies are based on multifunctional teams. Agility and economies of scope will allow the teams to apply their expertise to a heterogeneous computing environment. Data will be managed, stored, and distributed on a network accessible from engineers' desktops. An evaluation of the processes of creating and sharing data will result in solutions consistent with established business plans. Our commitment to concept-to-product systems will eliminate the need to re-input information and will permit data sharing among multidisciplinary design and manufacturing teams.

Numerous initiatives are under way to realize the engineering information system vision. Tools for mechanical design were identified by the ACCORD project selection that rests on a tightly integrated solid-modeling foundation. This approach uses the concepts of rapid prototyping and early product visualization to contain cost in the development stage.

The NIRVANA project tools for electrical design and fabrication provide the necessary flexibility and infrastructure. Record-of-assembly and product test databases will migrate from mainframe systems to smaller, less expensive, and more easily maintained workstations. Engineering information created at Sandia's New Mexico and California sites will be stored electronically at a single location that allows managed access from both sites.

An electronic configuration management system is

being developed to monitor and control design changes. Native electronic files and scanned images will be placed in an optical disc storage system for off-line storage and recall of electronic drawings, documents, and models to engineering workstations. The trend is from a secure computing network to restricted and open environments that will facilitate concurrent engineering with outside agencies throughout the product development cycle.

### **Primary Standards**

Sandia provides primary physical, electrical, and radiation standards for equipment calibration for the entire nuclear weapons complex. Sandia's Primary Standards Laboratory Metrology Program ensures accurate measurements for the nuclear weapons program. In addition, it supports other DOE programs, government agencies, industry, and universities. The program develops and maintains primary standards that are traceable to national standards, and calibrates and certifies customer reference standards. The program also provides the following services: technical guidance, support, and consultation; precision measurement techniques; and oversight activities, including technical surveys and measurement audits.

Development programs ensure the timely introduction of standards for new technologies. A current development is the portable Josephson volt, which will permit this intrinsic standard to be used in many field applications, ensuring quantum-level accuracy on voltage standards, digital dividers, and other ultraprecise test equipment.

Sandia's Primary Standards Laboratory performs more than two thousand calibrations of top-level standards each year in more than eighty different areas of technology for the integrated contractor facilities within the nuclear weapons complex. The standards laboratories at various contractor sites use these standards for as many as 300,000 calibrations a year on their own instruments. Primary Standards Laboratory operations are being relocated to a new facility with state-of-the-art environmental control.

The future focus of the Primary Standards Laboratory will include support for the reconfigured nuclear weapons complex and advanced manufacturing initiatives. This will require the development of new metrology disciplines such as chemical standards.

This standards program ensures the accuracy of all the metrology equipment used in the research, development, design, test, stockpile evaluation, and retirement of nuclear weapons.

### **Container Development and Production**

Special containers for the safe storage and/or transportation of nuclear weapons and nuclear weapon components are increasingly in demand. This demand is the result of high weapon disassembly rates and strin-

gent certification requirements for transportation containers to withstand accidents. Several types of containers are needed to satisfy significantly different requirements.

Sandia has unique experience in designing and certifying low-cost, regulatory-compliant containers that satisfy international quality standards. Sandia has designed and produced containers for safely shipping and storing nuclear weapons since the advent of nuclear weapons. These containers relied on auxiliary equipment and facilities to meet many of the safety requirements. Federal regulations for shipping components now require that the containers provide this ability, so we are presently focused on developing containers for components.

We have completed the design certification and production of 2,300 containers for tritium reservoirs and their associated leak test equipment. We have just completed the design and certification of a pit container for the former Soviet Union. The Defense Nuclear Agency is producing 30,000 of these. We are well along in the design of the American pit containers and certification is under way. The American container project requires Sandia to provide welding processes, robotic process machines, container reopening equipment, and container design. These activities will assist DOE in meeting international agreements and national nuclear shipping and storage requirements.

### **Materials Capabilities**

Analysis and modeling of materials, semiconductors, printed circuit boards, and all other production processes for the enduring stockpile are maintained under this program. We have worked closely with the nuclear weapon production agencies and, as a result of activities associated with the nuclear weapons complex, we expect the resources and expertise within this program to be fully utilized in the transition of production responsibility.

This program has traditionally provided a rapid response to material and process issues detected within the production cycle or discovered during stockpile surveillance. There will be more demanding needs in the future to develop and maintain a capability to produce prototypes and limited quantities of war-reserve semiconductors, neutron generators, batteries, and switch tubes. Associated with this maintenance of capability will be strong efforts to develop advanced, agile investment casting processes that will be used within the streamlined production complex and shared with US industry.

Semiconductor efforts will maintain a very strong analytical modeling capability (for radiation behavior, tolerance, design, and fabrication), preserve and improve an experimental failure analysis capability, and maintain and improve a technology base that can be applied to reliability and semiconductor life expectancy predictions. In the future, we expect that weapon systems will have much longer service lives. In addition, there will be

---

strong interaction with semiconductor manufacturers to assist in the privatization effort. The ability to experimentally evaluate radiation hardness is another differentiating capability that needs to be preserved.

Many materials analysis capabilities and facilities are used in the stockpile support program. In addition, a significant effort continues to qualify new materials and processes for printed circuits, hybrids, and encapsulants for future application.

Further development of the rapid production of investment cast prototype hardware (FASTCAST™) process will provide a concurrent design and manufacturing platform for the production of electronic housings. Sandia's accomplishments in developing the system architecture, thermal code, and complete integration into an agile manufacturing platform are well recognized by industry.

Because of our stewardship of the nuclear weapons stockpile, it is important that we maintain test facilities critical to the evaluation of nuclear weapon power sources and neutron generators. As required by new safety mandates or because of technology obsolescence, tester hardware and software modifications will continue as long as a nuclear weapons stockpile exists.

## *Change Initiatives*

### *Dismantlement Support*

Under the terms of the Strategic Arms Reduction Treaty (START) I and START II, the United States will be required to dismantle more than 10,000 nuclear weapons. Due to the backlog of weapons and the full pipeline of returns, DOE's Pantex plant in Amarillo, Texas will dismantle 2,000 weapons per year until the 1997-1998 time frame, when the requirement will drop to a few hundred per year to meet DoD retirements. In the past, the volume of weapon retirements was generally low enough that disassembly operations were performed as a work filler between assembly operations. The accelerated stockpile reduction and the nation's increased concern for the environment require that Sandia's broad technological base and systems integration expertise be used to assist DOE in downsizing the stockpile. For many operations the development of new dismantlement processes is essential to meet the immediate workload schedule and to provide a way of supporting future operations.

Dismantlement begins when the military designates a weapon for retirement and ends when DOE has disposed of the weapon components, handling equipment, and associated hardware. The procedure includes transportation, storage, and disassembly into subsystems and components that are recycled, staged for reuse, evaluated for information about the enduring stockpile, or prepared for disposal.

Sandia works closely with DOE's Pantex plant to

design safe and efficient processes. Automated processes using robotics and computer modeling are developed to safely and cost-effectively handle the increased dismantlement volume. Sandia system analysts are helping to automate dismantlement by scheduling the return and staging of retiring weapons, analyzing the processes for security and safeguards, prioritizing retirement and disassembly, and providing risk assessment management. Engineers are developing computer models to improve the transportation and staging of weapons.

Robotics is being used to mitigate personnel hazards, particularly those associated with radioactive material. Sandia and Pantex are developing a system called Stage Right that uses remotely controlled forklifts to load, unload, and inventory pits in storage containers for magazines at Pantex. The Secretary of Energy has approved the use of a new storage configuration (multiple horizontal layers versus a single vertical layer) and thirteen additional magazines to increase the pit storage capacity from about six thousand to the twelve thousand projected after three more years of dismantlement. A site environmental impact statement is planned at the end of that period. A shielded forklift will be used as an interim measure until the remotely operated vehicle is ready in late 1995. Plans are in place to use robots for cleaning, leak checking, and weighing nuclear weapon parts. The feasibility of using robotic systems for disassembly of explosives and radioactive parts and for the separation of materials for disposal is being studied.

Concern for the environment introduces new challenges in the disposal of materials. For example, new federal and local regulations require that certain materials scheduled for disposal be identified (lead in solder, copper in electrical wiring, cadmium in plated metal parts, etc.). Because original assembly drawings do not describe materials in sufficient detail, material analysis techniques and statistical sampling techniques continue to be developed. Sandia has developed a common materials database to be used by all design and production agencies. A short-term concern is Texas' possible preclusion of open air detonation or deflagration of explosives at Pantex. Sandia is examining alternative disposal techniques.

Disposal of subsystems and components often requires declassifying, demilitarizing, and sanitizing. Sandia engineers are exploring new processes to perform these functions simultaneously. Because of the immediate need, two commercially available technologies (forge hammer fracture and waterjet cutting) are now available at Sandia and Pantex. Improved automated technologies are being investigated for future operations.

The role of Lawrence Livermore, Los Alamos, and Sandia national laboratories in operations at Pantex has been expanded at the request of the DOE Albuquerque Operations Office. Formal reviews and quality evaluation for dismantlement have been instituted to require laboratory teams to review all dismantlement procedures

and operations for safety assurance. Formal dismantlement program reviews have been instituted similar to those done in development. The most recent initiative requested by DOE is for the laboratories' team to develop weapon disassembly procedures and processes for cells at Pantex using modern technology to achieve safety through design rather than by reviews.

### ***Manufacturing Development Engineering***

The manufacturing development engineering concept requires that design laboratories work directly with commercial vendors to develop and manufacture nonnuclear weapon components in the private sector. This concept requires high-level interaction between the design laboratory and private industry, including identifying and developing private sector suppliers, transferring technology, and maintaining an involvement with process design and manufacturing engineering.

Manufacturing development engineering will provide the following advantages to DOE in the anticipated very-low-volume production environment of the future nuclear weapons complex:

- By relying on private industry for production of weapon components, the nuclear weapons complex will require less overall production capability.
- With weapon component technologies maintained at the design laboratory rather than at a production agency, the maintenance cost of manufacturing development engineering technologies will be reduced.
- Components manufactured using high-volume, standard industrial processes will be more cost-effective and better characterized than components manufactured using low-volume, custom processes.

The strategic objectives of the manufacturing development engineering program are to

- develop an infrastructure that will demonstrate Sandia's ability to manage the production of nuclear weapon components in house (e.g., neutron generators) and via commercial suppliers,
- increase design engineers' general understanding of manufacturing issues and industry standards, products, and processing,
- move Sandia toward concurrent engineering and agile manufacturing, and
- facilitate the reconfiguration of the nuclear weapons complex by transferring appropriate activities

formerly performed at the Mound and Pinellas facilities to private industry.

### ***Nuclear Waste Complex Technologies Development***

Our development of technologies for the nuclear waste complex derives from the fact that consolidating the current nuclear weapons complex will require an investment in the development and demonstration of advanced manufacturing technologies. Sandia is developing these advanced manufacturing technologies in conjunction with the private sector to enhance the relevance of the technologies and to demonstrate the agility of advanced manufacturing technologies in meeting the requirements of nuclear weapons production and US industrial needs. We are investing in technologies such as computer-aided design and manufacturing, concurrent engineering, information-driven architectures, environmentally conscious manufacturing, and rapid prototyping. These are the same technologies needed by US industry. We are also exploring the integration of manufacturing sites into a virtual factory to meet the requirements of the future complex.

The work associated with the nuclear waste complex will reach beyond the needs of the nuclear weapons community. Sandia's program is directed toward becoming a test bed for research, development, and manufacturing integration and a place for developing new industrial processes. The program can be a working model of fully integrated manufacturing technologies and a centerpiece for DOE contributions to advanced manufacturing.

### ***Environmentally Conscious Manufacturing***

The environmentally conscious manufacturing program reduces environmental impacts of manufacturing activities without reducing the quality or performance of the product. Sandia has a strong commitment to both the environment and the quality of the nuclear weapon stockpile. Therefore, we will continuously develop the materials and processes used in the fabrication of weapon components to minimize their impact on the environment.

Environmentally conscious manufacturing focuses directly on manufacturing activities, as opposed to cleanup and restoration. Even though remediation technologies are essential for correcting past mistakes, reliance on end-of-pipe solutions must not be the basis for future manufacturing decisions. Any attempt to remove an environmental threat after its creation is almost certain to be less effective than avoiding that threat from the beginning.

Because our principal product is nuclear weapons, we cannot allow any manufacturing initiative to degrade the safety or reliability of the stockpile. However, opportunities for reducing waste and environmental damage exist. For the foreseeable future, Sandia's environmentally

---

conscious manufacturing efforts relative to weapon component production will be directed toward needs specific to the long-term stockpile.

A major benefit of Sandia's environmentally conscious manufacturing will be materials and processes vital to commercial enterprises. Maintaining a robust domestic economy with substantially less waste and resource consumption will be one of the greatest challenges of the next century. Sandia's unique blend of manufacturing and environmental experience is well suited to addressing this challenge.

### ***Reconfiguration (GB03 and GB0508)***

The aging nuclear weapons production complex is a widely distributed, environmentally outdated, expensive collection of sites built to meet peak Cold War demands. As production requirements decrease, the weapons complex must become smaller and less costly while maintaining its technical competence.

DOE is consolidating the complex and increasing its efficiency by integrating the essential competencies that exist in the weapons laboratories, the private sector, and the remaining weapons production sites (Kansas City, Y-12, Savannah River, and Pantex). This consolidation plan assigns Sandia responsibility for prototyping and small-lot fabrication of neutron generators and thermal batteries. Conceptual design studies and activity transfer plans have been prepared to examine the feasibility of producing these components at Sandia.

During the past two years, DOE's plans to reconfigure and consolidate the nuclear weapons complex have included tighter integration of the weapons laboratories with the production complex.

### **Office of Nonproliferation and National Security**

Sandia supports DOE with research, development, and analysis for intelligence, proliferation detection, arms control, verification technology, and policy development. Sandia has one of the oldest and largest programs of such work in support of US national security policy. This work continues to complement our nuclear weapon research and development responsibility, which provides expertise for knowledgeable nonproliferation and arms control research and development.

### ***Verification and Control Technology (GC, GJ, GD, and WFO)***

The Verification and Control Technologies Program includes research and development for a variety of systems, technologies, and processes for detecting

proliferation of weapons of mass destruction and for verifying agreements for transparency and arms limitations. An increasingly important aspect of all these program areas is Sandia's activity in information management, fusion, and analysis. Because the political framework within which these technologies are implemented reflects national and international momentum toward openness, Sandia is evaluating its advanced monitoring technology to strike a proper balance between supporting national goals of openness and transparency and ensuring that sensitive national security information (particularly that regarding intelligence sources and methods) continues to be safeguarded.

### ***Technology Development Programs***

Sandia is developing new sensors to detect low-yield nuclear explosions in the atmosphere. Instrumentation being deployed on the global positioning system satellites will soon provide continuous worldwide coverage. Data from these instruments are also used by DoD, which shares system costs.

We are developing satellite-based systems and technology for detecting and characterizing nuclear proliferation activities. These systems and technologies have potential application to detection of chemical weapons, biological weapons, and missile development. In conjunction with Los Alamos National Laboratory, we are developing an advanced multispectral thermal imager. Working with Los Alamos, Lawrence Livermore, Pacific Northwest, and Brookhaven national laboratories, we are developing laser-based techniques for remote detection and identification of chemical species in effluent plumes emanating from suspect sites. Both of these concepts could be developed into operational integrated systems and demonstrated in space aboard small satellites.

Sandia is developing chemical sensors related to nuclear and chemical weapons, ultraviolet light detection, light detecting and ranging technology, radiation detection sensors, remote video surveillance systems, and the nondestructive determination of particulate compositions. In some instances, component technology will be incorporated into unattended and possibly remote ground-based sensor systems.

We develop synthetic aperture radar systems for a wide variety of treaty verification and nonproliferation applications. We are also exploring the integration of synthetic aperture radar with other imaging data and automated data analysis to handle the large volume of data from such systems. Synthetic aperture radar will be used for all-weather and day-and-night aerial inspection.

Tags and seals are being considered for use in securing key elements associated with the Chemical Weapon Convention, weapon dismantlement, and the containers designated to transport and store US and Russian special nuclear material. Sandia has broadened the tag and seal effort to include information integrity, which covers the

---

general application of tags and seals to a wide range of monitoring applications. Data authentication techniques are being developed to provide security for remotely monitored, sensor-based sealing systems.

Sandia is developing a technology base for fiber-optic tags and seals and advanced tamper-indicating packaging. The technology base developed for these applications will to the extent possible use input from private industry, the university community, other national laboratories, and centers of expertise within Sandia.

Studies are under way to investigate the impact on DOE facilities of nuclear weapon dismantlement and special nuclear material controls in the context of various treaties, agreements, and transparency arrangements. One of our tasks is to design and develop a secure container for the safe transportation and storage of special nuclear materials. This work provides some of the background necessary to support discussions with Russia on nuclear weapon dismantlement.

Seismic technology is being developed to detect, locate, and identify nuclear explosions under ground and under water. In line with the emerging geopolitical climate, the emphasis of this program has shifted from monitoring bilateral test limitation agreements to global monitoring for a comprehensive test ban, as well as monitoring of proliferation-related nuclear testing. Our research and development is part of a multilaboratory effort focused on verification-quality seismic and hydro-acoustic data acquisition and data processing that is affordable, easily deployable, and flexible. Our technology development activities are being coordinated, and in many cases co-funded, by DoD, which has the operational nuclear test monitoring responsibility within the US government.

### ***Export Control and International Atomic Energy Agency Support***

We are increasing our activities in managing potentially large volumes of proliferation-related information. We intend to develop technologies that an analyst can use to turn vast quantities of data into useful information. Advanced data authentication techniques are employed when information security is paramount. Sandia has also temporarily assigned knowledgeable personnel to DOE Headquarters to help develop both domestic and international proliferation information management systems. We support the evaluation of export licenses in weaponization technology, drawing on our considerable experience in the engineering of nuclear weapons.

Sandia provides analytical support for the Office of Export Control's International Atomic Energy Agency activities. Analysis includes evaluation of various proposed inspection regimes, evaluation of International Atomic Energy Agency information management technology and procedures, and technology development support for ongoing International Atomic Energy Agency inspections.

### ***Nonproliferation Policy***

Sandia supports the Office of Nonproliferation Policy in regional arms control. Sandia has a program to evaluate the applicability of various arms control technologies and procedures to regional security issues. Prototype monitoring facilities can be developed so that representatives of regional parties (from South Asia, the Middle East, the Korean peninsula, etc.) could perform hands-on evaluation of various technologies and use models to simulate the appropriateness of technological solutions to their particular regional problems.

### ***Policy Analysis***

Sandia's policy support activities target both sides of the policy/technology interface. We support technical analysis of policy options for DOE and provide national security policy insight to Sandia organizations. Our direct support includes furnishing technical advisors to DOE Headquarters and the International Science and Technology Center in Moscow.

Analytical support for DOE includes treaty implementation analysis, staff support, nuclear testing analysis, and dismantlement analysis. Sandia has been a mainstay of DOE's on-site evaluation program since 1986, and continues to support evaluations of the impact of on-site inspections on sensitive industrial facilities and of other issues related to implementation of various treaties.

After formal comprehensive test ban negotiations in Geneva, Sandia has participated in various evaluations of the impact of further testing restrictions on our ability to act as stewards of the remaining nuclear stockpile. In addition, Sandia is providing guidance to policy makers about the verifiability of various proposed test-related treaties.

As the superpower stockpiles are reduced and their respective infrastructures consolidated, numerous issues will arise concerning verification and monitoring of the reduction, the residual weapons, and the components and materials resulting from dismantlement. Sandia has long evaluated the processes, procedures, and technologies associated with these dismantlement activities, and this support is expected to continue.

### ***Intelligence Support Activities***

Sandia has a long history of support for the intelligence community via both DOE's Office of Foreign Intelligence and other agencies. Our support has focused on foreign technology assessment and technology development.

As the national intelligence horizon has expanded to emphasize information management, Sandia has responded with programs to assist the intelligence community with tools and analysis techniques. For example, we provide tools for evaluating the wide range of multisource information now available, especially information relevant to assessing the proliferation of

---

weapons of mass destruction and their delivery systems. In addition, evaluations of information surety, a special expertise required by the nuclear weapons program, are increasingly provided to the intelligence community.

Although information management and proliferation-related tasks are of vital importance, this new focus has not supplanted Sandia's traditional intelligence support mission. We continue to enhance our intelligence collection and exploitation role by developing new sensor systems and evaluating foreign technologies for a variety of customers.

## Office of Environmental Restoration and Waste Management

### *Defense Waste and Environmental Restoration (EW)*

Work for the Office of Environmental Restoration and Waste Management includes environmentally conscious manufacturing technology, waste management technology, hazardous material transportation, waste repository technology, and waste management and minimization for Sandia. Work performed for this office includes site-specific corrective actions under the Environmental Restoration Program.

### *Environmentally Conscious Manufacturing*

Sandia plays a key role in developing and demonstrating environmentally conscious manufacturing technologies and using them to manufacture nonnuclear weapons components. These efforts focus on electronic assemblies and electromechanical components, reducing the use of hazardous or environmentally injurious materials during weapon production. A concurrent goal is to transfer these environmentally conscious manufacturing technologies to US industry after demonstration for weapons production, resulting in increased competitiveness and decreased environmental cost during manufacture.

The focus of this effort is integrated demonstrations to document benefits. Examples include the Environmentally Conscious Manufacturing Integrated Demonstration (a collaborative program with the Allied-Signal Kansas City Plant) and the waste component recycle, treatment, and disposal integrated demonstration program.

In the integrated demonstration, a total systems approach is used to identify environmental improvement opportunities and eliminate generation of hazardous wastes during the manufacture of electronic components. The systems approach is used to identify areas where hazardous waste is generated or where workers could be exposed to hazardous materials. Opportunities for replacing these materials and processes with environmen-

tally benign manufacturing technologies are also identified: replacement of hazardous organic compounds such as chlorofluorocarbons and chlorinated hydrocarbons with semiaqueous and aqueous cleaners; application of urethane foams and elastomers that do not contain carcinogenic precursors; use of no-clean fluxes and fluxless soldering; methylenedianiline-free printed wiring boards; chromium-free metal coatings; and safe marking inks. Life-cycle analyses, including costs and benefits associated with the new technologies, are key to the demonstrations.

These programs involve the following: research and development of technologies and methodologies for life-cycle analysis and decision-making at Sandia; coordination of complementary development and demonstration of the technology and life-cycle methodologies at Allied-Signal Kansas City; coordination of research at US universities and private industry; identification, evaluation, and development of environmentally friendly alternative technologies; and technology transfer through ongoing partnerships with companies in the US microelectronics industry. These programs consider both environmental impacts and cost trade-offs.

Another environmentally conscious manufacturing program is an assessment of waste minimization for common DOE-wide waste streams, which provides information to reduce waste and replaces hazardous materials in surface coating, metal finishing, and precision machining. Also, the environmentally conscious manufacturing technology program addresses hazardous material substitutions and develops software assessment tools to allow designers and small businesses to readily determine if they meet occupational safety and health and Environmental Protection Agency standards.

### *Waste Management*

Sandia is involved with a wide variety of waste management activities. Our waste component recycle, treatment, and disposal integrated demonstration for DOE develops regulatory-compliant technologies that can be demonstrated as complete systems for disposing of and recycling electronic components.

This demonstration focuses on electronic components from dismantled nuclear weapons. Many of these components contain hazardous materials such as heavy metals, polychlorinated biphenyls, self-contained explosives, and radioactive materials. In addition, those with classified significance are generally sealed in a potting compound, making them difficult to separate. This demonstration requires Sandia's knowledge of systems engineering and techniques for separating hazardous materials, as well as the integration of technologies from other laboratories and industries to help destroy unusable hazardous materials and recycle valuable portions of the weapon's electronic components.

The waste component recycle, treatment, and disposal



---

integrated demonstration complements the environmentally conscious manufacturing integrated demonstration by examining issues associated with separation, recycling, and ultimate disposal of process wastes. A systems approach identifies areas where improved/advanced recycling can be applied to a process. This includes quick separation of dissimilar materials (using an abrasive waterjet cutter, x-ray system, and recirculation system) to maximize recycling potential, rapid rubblization to facilitate recycles, multistep mechanical separation processes, and thermal treatment systems that simultaneously produce usable fuel gases (carbon monoxide and hydrogen) and allow metal recycling.

Other waste management technologies being developed include the following: silica crystalline titanates for treatment of radioactive waste removed from the Hanford underground storage tanks; steam reforming for destroying organics and nitrates in a variety of waste streams; monitoring and control systems for metal emission control systems for incineration processes; waste dislodging and conveyance technologies for underground storage tanks; supercritical water oxidation destruction of explosives and propellants; and solar detoxification of waste.

### ***Environmental Restoration***

The DOE Environmental Restoration Program was initiated in 1987 to consolidate and coordinate regulatory compliance activities that identify and remediate inactive sites at DOE installations contaminated with hazardous, radioactive, or mixed waste.

The Environmental Restoration Program addresses environmental problems resulting from past practices, assesses the extent and nature of these problems, and remediates sites as necessary using effective and cost-efficient methods. Activities include identifying inactive hazardous-waste release sites, developing an environmental restoration investigation and remediation program, coordinating National Environmental Policy Act documentation, obtaining necessary permits, evaluating surface and groundwater contamination potential, reviewing practices affecting sites with underground storage tanks, evaluating other waste management practices, and ensuring compliance with federal, state, and local environmental regulations. Projects involve the investigation and remediation of inactive waste-handling, disposal, and spill sites in accordance with the provisions of the Resource Conservation and Recovery Act, the Comprehensive Environmental Response, Compensation, and Liability Act, and relevant DOE orders.

Three primary regulatory drivers form the basis for environmental restoration program investigation and remediation: Section 3004(u) provisions of the Resource Conservation and Recovery Act, which require corrective actions for releases from solid waste management units; Resource Conservation and Recovery Act provisions

requiring closure and postclosure care for inactive treatment, storage, and disposal units; and requirements of the Comprehensive Environmental Response, Compensation, and Liability Act that address remediation of releases of hazardous substances in accordance with the National Contingency Plan. Most of the environmental restoration sites fall under the Resource Conservation and Recovery Act, but some will be addressed consistent with the National Contingency Plan.

Sandia's environmental restoration efforts are grouped in the following three categories:

- Resource Conservation and Recovery Act corrective actions required to address releases of hazardous waste or constituents from solid waste management units;
- Resource Conservation and Recovery Act closure actions pertaining to inactive treatment, storage, and disposal units that will not be permitted for continuing operation; and
- other actions to assess or remediate sites where a release has occurred or where a substantial threat of a hazardous substance release exists.

In 1992, Region VI of the Environmental Protection Agency issued Sandia a permit that established a schedule for the assessment and remediation of sites under Resource Conservation and Recovery Act corrective action authority at Sandia/New Mexico.

### ***Hazardous Material Transportation and Crosscut Technologies***

The principal program for the Office of Environmental Restoration and Waste Management is a group of technical tasks that make up the transportation technology development program. This program includes projects in the following areas:

- advanced technology development, which characterizes materials (especially casting metals and brittle materials) that could be useful in transportation and waste management;
- packaging development, which works with projects to evaluate packaging applications and to resolve design feature and materials compatibility issues;
- engineering analysis, which fine tunes and applies thermal and structural analysis codes, develops code modules, and creates databases specific to transportation problems;
- certification and regulatory support, which provides technical expertise to DOE elements involved in

---

packaging certification efforts and supports DOE efforts in clarification, analysis, and change to regulations at the international and national level;

- environmental and system planning, which develops system analysis techniques, risk assessment codes, and data relating to transportation systems operations (including material flows, modal options, accident data, and phenomenology);
- testing to support package certification, confirm new design concepts, and provide results for code confirmation;
- transportation automation and technical assistance, which provides the TRANSNET technology transfer facility to furnish results of DOE work to a variety of users;
- transportation intelligent monitoring, which develops technologies to improve emergency response systems for DOE activities;
- geographic information systems, which develop links for routing, preferred route determination algorithms, and accident rate prediction codes; and
- source-term containment evaluation, which develops information and analysis techniques to set requirements for allowable package leakage.

## *Nuclear Waste Repositories*

### *The Waste Isolation Pilot Plant*

Sandia is responsible for experiments and performance modeling to demonstrate the long-term behavior and containment properties of the Waste Isolation Pilot Plant repository and its suitability for long-term disposal of DOE's transuranic waste. Sandia is providing a detailed geotechnical understanding of the Waste Isolation Pilot Plant Site (twenty-six miles southeast of Carlsbad, New Mexico) and scientific research on issues related to disposal of transuranic waste. Sandia is providing scientific assistance for the predisposal phase (expected to last through at least 1998) and other assistance to meet the requirements of the 1992 Waste Isolation Pilot Plant Land Withdrawal Act (Public Law 102-579). Sandia's activities are focused in the following seven areas:

- disposal room and drift system studies to understand how wastes will interact with the repository bedded salt;
- laboratory gas-generation studies to determine how the waste forms may degrade and chemically interact;

- sealing systems and rock mechanics studies to design short- and long-term barriers to prevent wastes from escaping mined entrances;
- Salado hydrology and transport studies to determine how liquids and gases flow into and out of the repository rock salt;
- non-Salado flow and transport studies to determine the properties of formations overlying the repository;
- performance assessment modeling of long-term repository behavior with the wastes emplaced; and
- other activities for compliance demonstration and management.

Disposal room and drift system activities consider backfills, brine, simulated waste, waste containers, disposal rooms, and test designs for laboratory and field experiments. These experiments will provide an understanding of important waste interactions to support development of source-term and gas-generation models.

The laboratory gas-generation experiments use simulated and real waste to study the effects of various waste degradation processes such as corrosion of metals, microbial decomposition of plastics and cellulose, and radiolysis. Such processes could impact the short- and long-term waste containment capability of the repository. These experiments will provide confidence that a gas-generation model based on thermodynamic principles and laboratory data can predict gas generation from actual transuranic waste from the DOE complex.

Sealing systems and rock mechanics experiments determine the properties of salt, concretes, clays, and other fillers in laboratory and field settings. These experiments evaluate rock mechanics properties of the repository and overlying rock formations when penetrated by shafts, boreholes, and disposal rooms.

Salado hydrology and transport laboratory and field studies measure hydrologic parameters of the salt such as permeability, threshold pressure, and two-phase flow. Experiment results are input to databases and models of brine and gas transport into and away from the repository.

Non-Salado flow and transport experiments use laboratory and field studies to measure hydrologic and chemical transport parameters of formations overlying the repository. Laboratory experiments are developing models of radionuclide transport properties under present and anticipated conditions.

Performance assessment uses input from databases and models of the preceding activity areas to model the predicted performance of the Waste Isolation Pilot Plant as a geologic repository for nuclear waste. The results will be included in the compliance application that DOE will submit to the Environmental Protection Agency as part of the demonstration of compliance with regulatory

requirements. This will be a significant part of the basis for the disposal decision by the Secretary of Energy.

Other activities are concerned with integration and management. These activities include responses to inquiries from oversight groups, definition of the inventory needed for performance assessment, and industrial safety.

### ***Greater Confinement Disposal Project.***

Sandia has been selected by the DOE Nevada Operations Office to lead and conduct technical compliance assessment analyses for the Greater Confinement Disposal Project. The Greater Confinement Disposal Project site, located within the Radioactive Waste Management Site at Area 5 of the Nevada Test Site, has been proposed for the permanent disposal of a small amount of transuranic waste that does not meet the waste acceptance criteria for other waste repository programs. These wastes have been included in a category termed special-case wastes, requiring an alternative disposal method. In order for the waste to remain emplaced, the Greater Confinement Disposal Project facility must demonstrate compliance with the Environmental Protection Agency's standard for disposal of high-level waste, transuranic waste, and spent fuel.

Sandia's role in the Greater Confinement Disposal Project includes the following: development and implementation of a compliance assessment strategy for all applicable rules and regulations; model development and application for all Greater Confinement Disposal Project performance assessment activities; design and conduct of site characterization activities supporting Greater Confinement Disposal Project performance assessment; analyses to identify the suite of potential special-case wastes and to evaluate alternative disposal system configurations for possible future use of the Greater Confinement Disposal Project concept for special-case waste disposal; technical program integration; and development and implementation of an overall project strategy.

### ***Waste Management Operations***

Sandia's program for waste management requires staff training, equipment and supplies, contractor support, and funding associated with the management, collection, packaging, storage, transportation, treatment, and disposal of chemical, radioactive, and mixed wastes at Sandia in California, New Mexico, and Nevada. The waste management program encompasses guidance to Sandia generators of waste, surveillance of compliance, provision of qualified personnel to interact with DOE and the Environmental Protection Agency and states on waste issues, preparation or review of waste permit applications, and review of requirements changes to assess programmatic impact. The program also collects, stores, and

arranges off-site shipment, treatment, and disposal of wastes. Resource Conservation and Recovery Act storage occurs at ninety-day accumulation areas, at interim status facilities, and at the permitted hazardous waste management facility. Radioactive and toxic wastes are stored on-site at various facilities.

### ***Pollution Prevention Operations***

This program will use antipollution technology and employee education to ensure that environmental protection becomes an integral part of everyday activities at Sandia. The objective is to reduce or eliminate the generation of hazardous, mixed, transuranic, low-level, sanitary, and other wastes in research, design, and operations.

The program will incorporate pollution prevention into the design and implementation of new projects, will continuously improve existing projects, and will provide a comprehensive system of employee and contractor incentives.

### ***Performance of DOE Nuclear Waste in Future Repositories***

Drawing on work from other geologic disposal projects, Sandia is examining possible options for the treatment of highly enriched spent fuel from DOE military and experimental reactors and for high-level waste generated from past processing of some of this defense spent fuel. The waste is currently stored at the Idaho National Engineering Laboratory and throughout the DOE complex. Sandia is helping the Westinghouse Idaho Nuclear Company by providing expertise in performance assessment methodology. Sandia's performance assessment evaluates possible treatment options by assessing the long-term behavior of the resulting waste forms in hypothetical, deep-geologic repositories in salt, granite, and volcanic tuff and then calculating performance measures for comparison with applicable environmental regulations. This assessment is part of the waste management technology development program designed to help DOE develop and demonstrate the capability to permanently dispose of its spent fuel and high-level radioactive waste, as mandated by the Nuclear Waste Policy Act of 1982.

### ***National Transuranic Program***

The National Transuranic Program Office, part of the DOE Carlsbad Area Office, is developing a system-wide management capability to integrate the transuranic waste system. Sandia will provide expertise for systems engineering analysis and development of strategic and long-range implementation plans that support the goal of cleaning up the complex in thirty years. Carrying out these plans through the DOE budgeting process will require an annual evaluation of progress against the implementation plan and a readjustment of the documents to keep the National Transuranic Program on course.

---

## Energy Programs

Sandia supports DOE's goals of providing secure and environmentally acceptable energy supplies by improving energy production, conversion, and use. Drawing on more than twenty years of experience in energy research and technology development, Sandia now specializes in areas that leverage its research, design, and manufacturing capabilities.

Our current programs include high-temperature superconductor research for electric power systems, stationary battery storage systems for utilities, geothermal energy systems, solar electric technologies (photovoltaic and solar thermal), wind energy, industrial and transportation applications, fossil energy programs, and projects that address the complete life cycle of nuclear energy needs. These programs mesh with industry, allowing Sandia to develop a strong record in technology transfer.

### Assistant Secretary for Energy Efficiency and Renewable Energy

Sandia's energy programs are integrated to better assist DOE in developing creative solutions to global energy problems and reduce the impact of energy use on the environment. To this end, we use Sandia's capabilities to bring in appropriate expertise, and we collaborate with US industry, government agencies, and universities to suggest economical, practical, environmentally friendly answers to worldwide energy issues. We are helping to make US energy technologies cost-competitive in a global market.

Sandia's multiprogram structure provides a resource for the nation in systems analysis, technology development, and engineering design. We use these crosscutting strengths to assist in ensuring the nation's energy security. Furthermore, we undertake research and development for DOE to solve anticipated energy needs.

The staff in our program areas of renewable energy, fossil energy, and energy efficiency initiate and maintain technical collaborations with industry and users to solve problems and curb pollution (renewable energy does not pollute).

The economic viability of energy technologies in the United States is a major concern. We work in cooperation with DOE and in partnership with industry to strengthen the competitive position of US industry. Sandia's principal contributions are providing engineering studies to identify preferred system applications and configurations, testing, fielding and evaluating prototype systems, and modeling and analyzing current and projected situations. We view our efforts as international, supporting DOE's global policy.

### *Electric Energy Systems (AK)*

Sandia is developing practical, high-temperature superconducting wire and magnets to improve the efficiency of electric motors, generators, and transmission lines and to provide fast-discharge energy storage in the form of superconducting magnetic energy.

This work contributes to optimized high-temperature superconducting materials, conductor fabrication technology, and the design and evaluation of prototype devices that can improve the efficiency of electric power generation and distribution systems. We actively involve industry in all of this work.

### *Energy Storage Systems (AL)*

Sandia is working with industry to develop advanced rechargeable battery systems for utility energy storage applications as part of the DOE utility battery storage systems program. Cost-shared contracts with industry partners develop both components and systems. Sandia's technical expertise is used to manage these contracts, analyze the benefits of battery storage in utility systems, evaluate prototype batteries, and conduct applied research.

### *Geothermal Systems (AM)*

Sandia's geothermal systems work will increase the nation's proven geothermal reserves and assist industry in expanding geothermal power use. We are developing new drilling and completion technologies to help expand the commercial use of US geothermal resources. The technologies we develop in this area can also be used in petroleum and mineral extraction.

Slimhole drilling is a new technique Sandia is perfecting to reduce drilling costs in assessing hydrothermal reservoirs. Our major work in geothermal systems includes developing high-temperature instrumentation for geothermal wells, acoustic telemetry to transmit downhole data through the drill pipe while drilling, and drilling a deep exploratory well in an active volcanic caldera in California.

### *Solar Energy (EB)*

#### *Solar Thermal*

Engineers in Sandia's solar thermal programs work with users and manufacturers of solar thermal energy systems to increase acceptance of solar thermal technologies. They emphasize cost-competitiveness for power generation and industrial process heat. Sandia operates the National Solar Thermal Test Facility, where we evaluate solar thermal technologies and perform special-

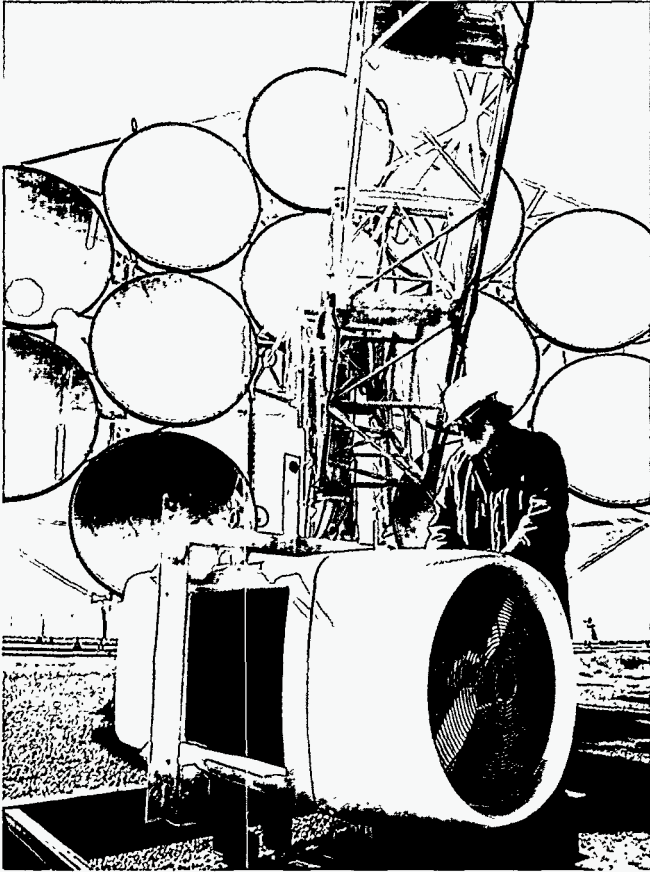

Sandian Tom Mancini inspects a Stirling heat engine that will be attached to the solar concentrator in the background. This system is part of a joint venture with industry to commercialize dish-Stirling technology.

ized tests requiring high heat, a capability used by both government and industry. Sandia provides technical support to Solar Two, a cost-shared project with a consortium of utilities to upgrade the Solar One power tower pilot plant using molten salt heat collection and storage technology.

Sandia conducts research and development of advanced solar thermal components, dishes, heliostats, and receivers for dish and central receiver systems, and also designs, analyzes, and tests components and systems. In a joint venture with industry, Sandia is developing the first commercial dish-Stirling systems. We operate a design assistance center that promotes the use of solar thermal technologies through services to manufacturers, operators, and decision-makers and through educational outreach.

### **Photovoltaics**

Sandia's work is centered on developing cost-effective,

reliable photovoltaic energy system technology produced by US industry and used worldwide. Through its Design Assistance Center, Sandia teams with other agencies to accelerate development and acceptance of the technology at home and abroad.

Sandia uses its engineering skills to assist industry in developing high-performance, low-cost concentrator cells, designing cost-effective modular technologies, and perfecting balance-of-systems hardware. It assists industry by providing accurate performance measurements, reliability testing, and evaluation.

### **Wind Power**

Sandia is developing wind turbine technologies to provide economical systems for commercial power generation. Sandia conducts applied research in aerodynamics, structural dynamics, fatigue, materials, controls, and systems integration to increase understanding of phenomena and provide more effective design tools.

Sandia has lead laboratory responsibility for vertical axis wind turbine technology and is also developing cooperative activities to transfer this and other technologies to the US wind industry. We will work closely with other national laboratories, wind turbine manufacturers, and wind farm operators to provide reliable, cost-effective solutions for domestic and international markets. Sandia engineers are developing user-friendly analytical tools for industry use and are identifying additional research needs.

### **Industrial Sector (ED)**

#### **Combustion Technology**

Combustion work at Sandia/California's Combustion Research Facility includes experimental, theoretical, and computational investigations aimed at reducing energy consumption, preserving the environment, and fortifying science and engineering foundations. This work utilizes the unique laser diagnostic capabilities of the research facility.

Sandia collaborates with industry on its combustion projects and concentrates on reducing toxic emissions without compromising fuel efficiency, developing improved technologies for internal combustion engines, and improving environmental technology systems for destruction of hazardous wastes.

#### **Materials Processing by Design**

These programs work to improve existing processes and develop new ones that are commercially and environmentally acceptable for the chemical, petroleum, durable goods, and semiconductor industries.

This work explores the underlying physics, chemistry, thermodynamics, and fluid mechanics of new processes for manufacturing commercially important chemicals,

powders, composites, coatings, and membranes. We make predictive models of high-temperature chemicals and materials synthesis processes that industry can use in its design, organization, and waste minimization efforts. We also use laser-based sensors to monitor and control manufacturing processes in the steel, chemical, petroleum, and semiconductor industries.

### ***Advanced Industrial Concepts/Materials Research***

Sandia's materials research work in the industrial technologies program provides computer-aided design, synthesis, characterization, and testing of new enabling materials with the potential for energy savings and waste reduction in industrial applications.

The present focus is on developing selective inorganic thin films for energy savings through improving performance of light gas membranes and catalysts, synthesizing composites by reactive metal infiltration, producing lightweight structural materials with improved performance, and developing novel catalysts for simultaneous conversion and separation of petrochemicals.

### ***Advanced Industrial Concepts/Biochemical and Chemical Technologies Research***

Sandia develops techniques for catalysis in projects that use computer-aided molecular design of biomimetic carbon dioxide activation catalysts. Research goals include the following: computer-aided molecular design of catalysts that mimic carbon-dioxide-activating enzymes; development of improved molecular modeling techniques; structural studies of carbon-dioxide-activating enzymes; synthesis, characterization, and testing of designed biomimetic catalysts; and integration of successful catalysts into a solar-driven process.

The project involves collaborative work with several industry and university groups.

### ***Industrial Waste Reduction Program***

Sandia collaborates with industry to develop and commercialize cost-effective waste reduction technologies and practices. The program focuses its resources on the problems of reducing wastes generated in manufacturing and improving the energy efficiency of industrial processes. The goal is to stimulate, facilitate, and coordinate development and transfer of waste reduction and energy saving technologies to industry.

The program uses cost-shared projects with industry and involves characterizing waste, assessing promising opportunities for waste reduction, and analyzing barriers to implementation of waste-reduction strategies. We transfer industrial waste reduction technologies to specific companies and to industry as a whole.

## ***Transportation Sector (EE)***

Sandia is developing technology to reduce the environmental impacts of the automobile by working on advanced batteries, hybrid systems, and such activities as the clean-car initiative. Engineers at Sandia are developing more efficient engine technology, improved emission catalyst and emission systems, and improved batteries for electric vehicles.

Sandia has a cooperative research and development agreement with the United States Advanced Battery Consortium for research and development on electric vehicle battery technologies. The objective is to advance these technologies to a level that will encourage industry to become a partner in the development program. If successful, industry would then begin development and commercialization of batteries for electric vehicles.

## **Office of Civilian Radioactive Waste Management**

Sandia's major activities for the Office of Civilian Radioactive Waste Management address transportation and geologic disposal of spent fuel and high-level radioactive waste. The work directly supports three strategic program goals: providing transportation of spent fuel, determining the suitability of Yucca Mountain as a disposal site, and providing for timely waste emplacement in a disposal facility. In addition, Sandia participates actively in the efforts to strengthen fiscal and program management practices. During recent years these efforts have included specific improvements in planning, budgeting, scheduling, reporting, record keeping, and quality assurance.

## ***Nuclear Waste Fund (DB)***

### ***Yucca Mountain Site Characterization Project***

The Yucca Mountain Site Characterization Project is investigating the feasibility of disposing high-level radioactive waste in unsaturated volcanic tuffs. The site is at Yucca Mountain in southern Nevada, adjacent to the Nevada Test Site. Sandia is a primary participant, collecting laboratory and field data, developing detailed models for individual processes, assessing the behavior of the total system, and estimating its long-term performance for comparison with regulatory standards. Sandia's specific responsibilities in this multifaceted project include the following:

- identifying the features, events, and processes that might affect the repository during the 10,000-year regulatory period and then constructing scenarios to develop numerical models that describe the future states of the repository system;

- performing laboratory experiments to understand fluid flow and radionuclide transport in unsaturated tuff (interactions between flow in fractures and in the rock matrix, nonisothermal effects, geochemical retardation, and scale-up problems);
- developing numerical models that describe the results of fluid-flow and transport experiments in the laboratory;
- assessing the effects of disturbances from the construction and operation of a repository, including thermal and mechanical changes in the host rock from hot waste;
- developing and evaluating conceptual designs for seals in the repository's boreholes, shafts, and drifts;
- using geostatistical data to construct three-dimensional representations of Yucca Mountain lithology to predict the location of rock units and for numerical simulations of the total system;
- using geophysical techniques and direct observation to assess rock-mass quality in exploratory shafts as an aid to construction;
- conducting studies that investigate the effects of climate change on infiltration and on the resulting percolation flux through the repository;
- conducting a performance assessment by abstracting appropriate models from detailed process models, linking coupled processes related to thermal, chemical, and mechanical interactions, performing stochastic calculations of radionuclide releases for the scenarios, and deriving complementary cumulative distribution functions for the releases; and
- developing decision-analysis capabilities to aid in cost-efficient data collection.

The information obtained from the above studies is being combined with information from other participants in total-system performance assessments to help judge the suitability of Yucca Mountain as a repository. These iterative preliminary assessments (two of which have been completed) are also used to help guide site characterization and design-related activities. Ultimately, the Yucca Mountain Project test and analysis results will be major parts of the license application that DOE will submit to the Nuclear Regulatory Commission. Completion of these assessments is essential to timely waste emplacement because assessments must be available for the commission to examine as it determines the suitability of the repository.

### ***Transportation Studies for the Office of Civilian Radioactive Waste Management***

Sandia's Transportation Technology Center continues to develop technologies for the design of safe and efficient systems for transporting spent fuel and for handling packages. The design and production of actual systems for transporting commercial wastes to interim storage or repositories are being performed in the private sector. The Transportation Technology Center will continue to participate in technology-base and technology-transfer activities for design optimization and certification of the new generation of waste packages to ensure safety throughout operations involving these packages. The center integrates these transportation technologies across the Office of Civilian Radioactive Waste Management (OCRWM) via participation in the development of the multipurpose-canister concept, which will ultimately meet requirements for the transportation, storage, and disposal of commercial fuel. Sandia also has unique capabilities for small- and full-scale testing that are being qualified for use in the future certification of OCRWM waste packages.

### **Assistant Secretary for Fossil Energy**

Sandia's fossil energy programs support DOE's goals by developing technologies that promote the clean and efficient use of the nation's coal, oil, and natural gas resources and by maintaining a secure economic supply of natural gas and crude oil. To this end, we evaluate the impact of fossil fuel use on the environment and team within Sandia to mitigate adverse effects of energy use.

Our program develops new technology in the following areas: designing and optimizing clean current and next-generation coal combustion systems; developing advanced catalysts and process concepts to convert natural gas and coal to environmentally compatible liquid fuels and for high efficiency natural-gas-driven fuel cells; providing scientific support to assure reliable design and safe performance of underground storage systems; and providing geophysical instrumentation systems for improved fossil energy reservoir diagnostics.

We maintain collaborative research and development partnerships with the coal, petroleum, natural gas, and fuel cell industries and with universities and other national laboratories. Our coal combustion programs interact strongly with US industry through the Sandia/California Combustion Research Facility users' programs. Our commitment to national security and DOE policy continues to guide Sandia's program efforts, including our support of the DOE Office of the Strategic Petroleum Reserve.

---

## **Coal (AA)**

### **Coal Conversion**

Sandia supports the research program implemented by the DOE/Pittsburgh Energy Technology Center by leading efforts in catalyst development for direct and indirect liquefaction processes. This work involves studying coal reactivity, understanding the relationship of reactivity to the molecular and macroscopic structure of coal, and developing advanced catalysts and catalytic processes for coal conversion.

Research is focused on the catalytic conversion of coal to liquid fuels at more moderate temperatures and pressures with optimum hydrogen use and with effective removal of sulfur and nitrogen. We are also using computer-aided molecular design techniques to study coal structure and design catalysts for the direct conversion of light hydrocarbons to alcohols and other liquid fuels. Sandia is establishing a center for the evaluation of catalysts for DOE's Fine Particle Catalyst Program.

### **Coal Combustion**

Sandia uses its Combustion Research Facility in conjunction with DOE's Office of Fossil Energy and with industrial partners in the United States to develop predictive models of the behavior of the organic and inorganic constituents in commercially important coals from the United States to use in the present and next generation of coal combustion systems.

The work includes determining the chemical kinetics and mechanisms of coal pyrolysis and char oxidation and determining the significance of the quality of coal on unburned carbon in the exhaust. The coal combustion effort conducts pilot-scale research to establish the mechanisms of transformation, release, and deposition of inorganic species during coal combustion, develops user-oriented models to predict the combustion and behavior of the ash of coals from the United States in current and in the next-generation coal combustors, and develops and validates optical diagnostic sensors for in situ measurement of state properties, gas species composition, and particulate loads in coal combustors.

## **Gas (AB): Natural Gas Research**

The natural gas program seeks to improve the production, quality, and utilization of natural gas from conventional and low-permeability gas reservoirs by combining comprehensive geologic characterization with the development of new reservoir stimulation technology and by upgrading, conversion, and delivery of natural gas products.

Sandia performs geotechnical studies in the areas of sedimentology and natural fractures, geomechanics and in situ stress, and reservoir stimulation. Sandia is develop-

ing a methodology to aid industry in understanding and exploiting natural fracture systems in US western basins. Sandia is also performing basic research in biomimetic catalysts for direct conversion of natural gas into fuel liquids.

## **Petroleum (AC)**

The petroleum program focuses on advanced reservoir evaluation technology and improved oil recovery. Sandia is developing superior geophysical techniques for improved reservoir characterization and in situ process monitoring. A key effort is the development of advanced computational capabilities for design and assessment of the many different source receiver variations that are possible, and the interpretation of field data by both forward and inverse analyses. Selected methods are evaluated in field experiments at various sites in conjunction with other national laboratories, industry, and universities.

Sandia is also developing technologies to improve production and recovery of domestic oil. A reservoir simulation has been developed that describes and predicts resistivity changes. Sandia has measured in situ stresses and other long-term phenomena in several producing fields, including the Ekofisk Field in the North Sea (in conjunction with Phillips Petroleum). This has led to a concept of geomechanics that views reservoirs as dynamic systems to be studied with full awareness of changing conditions over reservoirs' lifetimes. Sandia participates in DOE's Natural Gas and Oil Recovery Technology Partnership Program with Los Alamos, Lawrence Berkeley, and Lawrence Livermore national laboratories to match technology with the needs of the natural gas and petroleum industry. In FY 1995, the partnership will be expanded by the Advanced Computational Technology Initiative, an effort of nine multiprogram national laboratories to work on a cost-shared basis with the natural gas and oil industries to utilize, expand, and enhance the laboratories' advanced computational capability to find and evaluate oil and gas resources.

## **Strategic Petroleum Reserve (SA): Storage Facilities Development**

Sandia is developing technology for safe underground crude oil storage in the US Strategic Petroleum Reserve and to support commercial underground storage of petroleum liquids and natural gas. The program involves site characterization, engineering design assistance, and evaluation. The program fields instrumentation to provide long-term cavern monitoring, validate cavern creep closure models, assess the integrity of wells and casings penetrating the caverns, and certify the integrity



of caverns. In addition, engineers address specific geotechnical problems (e.g., the potential impact of water leaks on withdrawal of oil from mines) and conduct studies to determine optimum cavern drawdown scenarios based on geotechnical considerations.

The technology developed for cavern creation, testing, and operation is being applied to commercial cavern development for natural gas storage in a technology transfer program.

## Office of Nuclear Energy

Current efforts for the Office of Nuclear Energy focus on existing and advanced light water reactor technology. Nuclear power is an essential component of this nation's energy supply, and its environmental advantages are becoming known because of worldwide concern over the emission of greenhouse gases from fossil-fuel power plants. The United States has invested over \$200 billion in nuclear power facilities that generate 20 percent of its electricity. Nuclear power plants are licensed for forty years, but studies indicate that plant life could be extended by an additional twenty to thirty years. If an average of ten years of additional operation could be gained, \$170 billion would be saved.

Specific activities emphasizing Sandia's strengths include studies of the following: systems concepts, technology evaluation, safety and reliability, electronic devices operating in severe environments, management techniques to ensure functionality of aging equipment, component testing, engineering of high-reliability components, and materials behavior and degradation. Sandia has devised a step-by-step methodology for evaluating plant equipment (focusing on systems, structures, and components subject to age-related degradation) that may pave the way for safe, extended operation of nuclear power plants. The methodology is endorsed by the nuclear power industry as its technical approach to license renewal.

These efforts are expected to remain steady at current funding levels for Sandia, given new administration goals to support only light water reactor concepts.

## Nuclear Energy Research and Development (AF)

This work will improve the safety, reliability, and cost-effectiveness of commercial light water reactors, allow license renewal of existing light water reactors, and demonstrate simplified regulations for siting advanced light water reactors.

Sandia operates the Light Water Reactor Technology Center for DOE. Activities develop and implement reactor safety features and concepts that offer significant

safety improvements and longer operating lives, and develop approaches for improving the reactor licensing process. Projects include studying the technical, institutional, and economic aspects of extending the licensed lifetimes of commercial nuclear power plants, conducting technical studies in support of DOE's nuclear regulatory reform activities, evaluating Nuclear Regulatory Commission regulations being developed, and applying new techniques to the reactor licensing process.

We work with the nuclear power industry to resolve technical issues associated with extending the useful lives of light water reactors and demonstrating early site approval for advanced light water reactors. In addition, we will investigate improved approaches to licensing nuclear power generation plants and explore technological developments in support of future nuclear plant designs. This work is closely coordinated with industry, universities, and other national laboratories.

These programs form a basis for closer cooperation with industry. We have formed technology alliances with industry to couple Sandia's strengths with the nuclear power industry's experience and knowledge to address issues of importance to current and future nuclear power plants.

Also, Sandia will convert its Annular Core Research Reactor and the Hot Cell Facility from defense programs to medical isotope production programs to meet a critical national need in nuclear medicine. The primary objective is to provide a reliable domestic supply of molybdenum-99 to meet 100 percent of US demand in case the present Canadian sole source is disrupted. Secondary objectives include production of iodine-131, iodine-125, and xenon-133 and process improvements in production and use of a wide range of clinical and research medical isotopes. Additional objectives include production of other medically useful isotopes and research and development directed toward applications in industry, agriculture, and other areas. Preparation for molybdenum-99 production includes environmental, health, and safety evaluations and modification as well as physical plant changes and development of a production-oriented infrastructure.

## Science and Technology Programs

Sandia conducts numerous projects that contribute to DOE's science and technology mission. These projects include established activities in scientific computing, basic energy sciences, and magnetic fusion energy. Research in global climate change for the Office of Health and Environmental Research is a growing responsibility. Advanced computational techniques and information technology pervade these activities. Also, educational

---

outreach efforts are improving the nation's science and mathematics education infrastructure.

Sandia stresses three important themes in the execution of these research and development activities:

- excellence in scientific research;
- integration of basic research, applied research, and technology development; and
- impact on US industrial competitiveness.

One metric for excellence is winning national and international awards. During the past few years, Sandia researchers have won several such awards, including the International New Materials Prize (1993), the Dillon Medal (1991), the E. O. Lawrence Award (1985 and 1990), and the Karp Prize.

Every phase of Sandia's development cycle integrates science and technology. Examples include geoscience and technology, combustion science and technology, and scientifically tailored materials. In each case, basic research is integrated directly into the objectives of DOE technology programs.

Although this research and development composes only a small portion of Sandia's work, it has a major impact on our interactions with US industry. For example, nearly 60 percent of Sandia's cooperative research and development agreements originate in research for the Office of Basic Energy Sciences and the Office of Scientific Computing. Also, our projects are characterized by numerous interactions with US industry. In the coming years, these activities are expected to provide a basis for new DOE initiatives, missions, and roles.

## Office of Energy Research

Sandia's basic energy sciences activities provide the foundation for many energy and manufacturing related technologies. The Office of Scientific Computing funds a vigorous research program in the development and application of advanced computational techniques. Office of Basic Energy Sciences projects include a national mission in combustion science.

We expect to expand basic research during the planning period. Our magnetic fusion energy projects support both a long-term, nationally coordinated program and US participation in the international thermonuclear experimental reactor design project. In support of the Office of Health and Environmental Research, we are developing instrumentation and algorithms for measuring water vapor and cloud distributions. Sandia also provides DOE-wide technical direction of the emerging program in unmanned aerospace vehicles and small satellites.

These activities directly support Sandia's integrated capabilities in advanced manufacturing, electronics, advanced information, and pulsed power technologies that underpin electronics and manufacturing technology.

## Magnetic Fusion (AT)

Sandia's magnetic fusion program will develop a technology base to support the design of components that will perform satisfactorily in fusion plasma environments. To achieve this goal, we study the interactions of plasmas and materials, the behavior of materials exposed to high heat fluxes, and the interfaces of plasmas and fusion reactor walls. Extensive analysis of prototypes is required before components can be qualified for operation in fusion machines. This activity involves selecting, specifying, and developing materials for components exposed to high heat and particle fluxes. Materials samples and prototype components are tested in Sandia's Plasma Materials Test Facility. This facility uses high-energy electron beams to generate high heat fluxes that simulate fusion reactor environments. Materials and components are also exposed to actual tritium plasmas in Sandia's tritium plasma experiment, which has been relocated to Los Alamos National Laboratory. Materials from these tests are characterized using Sandia's accelerator facilities for ion beam analysis.

Sandia directly supports US and international fusion machines. This support includes the following: diagnostics, tritium inventory assessments, and materials studies for the Princeton Tokamak Fusion Test Reactor; material analysis and diagnostic development for the General Atomics DIII-D Advanced Diverter Project; and a full toroidal belt advanced limiter test (ALT-II) system for the TEXTOR Tokamak in Germany. Sandia designed and installed on the Tora Supra Tokamak in France an actively cooled pumped limiter capable of steady-state operation with a peak heat flux of 30 million watts per square meter.

In all these experiments, Sandia participates in machine operation and provides specialized diagnostics and data analysis for evaluating plasma material interaction processes, boundary layer plasma control, and plasma-facing components. In addition, Sandia continues to collaborate on plasma material interaction and high-heat-flux issues with both the Joint European Torus in Abingdon, United Kingdom, and the JT-60U in Japan. Recently, at DOE's direction, Sandia entered into cooperative exchanges on plasma-facing component development with several laboratories in Russia.

In 1992, an international agreement was reached by the United States, Japan, the European Union, and Russia to embark on a six-year engineering design for the International Thermonuclear Experimental Reactor. Sandia is supporting this project by providing personnel to help manage the program in the US Home Team and at the International Thermonuclear Experimental Reactor

---

Co-center in Garching, Germany. Sandia also has a major role in research, development, and design of plasma-facing components for the US effort. Continued international cooperation is essential to the success of the International Thermonuclear Experimental Reactor Project. Domestically, development of plasma-facing components for the project will be a cooperative effort of Sandia, other national laboratories (Argonne, Oak Ridge, Idaho, Lawrence Livermore, Los Alamos, and Princeton), universities (UCLA, University of Illinois, University of Wisconsin, University of New Mexico, North Carolina State University, Pennsylvania State University), and industry (headed by McDonnell Douglas and including Ebasco, General Atomics, Westinghouse, and Rocketdyne). Sandia is coordinating this multisector cooperative effort for the US International Thermonuclear Experimental Reactor Home Team.

Sandia's expertise in materials and components for magnetic fusion systems will support the Tokamak Physics Experiment (the next major US plasma confinement experiment) and the Large Helical Device, a stellarator confinement device being built by the Japanese National Institute for Fusion Science.

### ***Scientific Computing: Massively Parallel Computation (KC07)***

Sandia's computational sciences research develops methods for solving scientific and engineering problems and a software infrastructure for parallel computing. Research includes the development of algorithms for solving computational problems in physics, chemistry, biology, and engineering. Research in software infrastructure for parallel computing includes such areas as graphics methods and visualization, static and dynamic load balance methods, parallel operating systems, and performance evaluation methods. This program is designed to use the performance and cost advantages of massive parallelism on important DOE problems.

Advanced computing technologies are important to national and economic security. Sandia has a leading role in the national high-performance computing and communications program. Sandia also has leadership of two DOE grand challenges: computational design of catalysts and biocatalysts and rational drug design. We also have a major algorithm development responsibility for global climate modeling, a grand challenge led by Los Alamos. Our work on massively parallel computing has been recognized by several national and international awards, including the Gordon Bell Award, the Karp Prize, and two Research and Development 100 awards.

The massively parallel computing research laboratory at Sandia/New Mexico creates prototypes of advanced, high-performance computing technology, including scalable massively parallel algorithms, graphics and visualization, and systems software. Part of our strategy is

to form interdisciplinary partnerships with Sandia's DOE Defense Programs applications to create new simulation capabilities. It is also part of our strategy to move such advances quickly into industry through technology transfer.

The Center for Computational Engineering at Sandia/California is chartered to help scientists and engineers in industry use massively parallel processing to solve problems that are impracticable on conventional machines. The center focuses primarily on software engineering for applications. Applications being investigated include pharmaceutical design (such as drug/organism interactions and designer chemotherapy) and global climate change. Research at the center for computational engineering includes methodologies for problem specification, code generation, and data management, as well as theorems for performing proofs of software correctness.

### ***Basic Energy Sciences (KC)***

Sandia supports the Office of Basic Energy Sciences with several leading research efforts. Larger projects include combustion research and scientifically tailored materials. Smaller projects include engineering and geoscience research.

### ***Chemical Sciences***

#### ***Combustion Research***

Sandia's largest project for the Office of Basic Energy Sciences is at the Combustion Research Facility at Sandia/California. In this DOE user facility, Sandia staff and visiting researchers develop advanced research methods and apply them to the study of fundamental combustion processes.

The Office of Basic Energy Sciences supports basic research in combustion sciences at the Combustion Research Facility and also operates the facility as a research center available to a wide variety of users. Major users include researchers supported by the Office of Fossil Energy or by the Office of Energy Efficiency and Renewable Energy who conduct industry-oriented research in transient and continuous combustion (including coal and biomass processes) and in advanced materials synthesis.

DOE sponsorship and policies facilitate a vigorous visiting scientist program that attracts approximately eighty long-term users to the Combustion Research Facility every year. Visiting scientists conduct basic and applied combustion research and publish their findings. Visitors come from industry, universities, and government-sponsored organizations such as the national laboratories. Their participation in activities of the Combustion Research Facility is an important vehicle for transferring new combustion technology to a large user

---

community. An active postdoctoral research program provides advanced training for combustion scientists and engineers and enhances the facility's research productivity.

The continuing programs at the facility help maintain US preeminence in the science and technology of combustion. Facility staff represent the United States in International Energy Agency programs on Energy Conservation in Combustion. International Energy Agency activities involve collaboration with foreign scientists in engine studies and coal research through an informal exchange program.

The long-range objective of the facility is to accelerate the development of combustion technology to maximize energy efficiency, fuel utilization, environmental protection, industrial productivity, and equipment design. Research conducted for the Office of Basic Energy Sciences' Chemical Sciences Division includes combustion diagnostics, combustion chemistry, reacting flows, and combustion modeling.

One primary thrust of the research program is the development of advanced combustion diagnostic techniques. Because of their nonintrusive nature and great versatility, laser-based optical techniques receive the strongest emphasis. Laser-induced fluorescence, quantitative imaging, and nonlinear optical wave mixing are among the diagnostic methods being developed. These techniques are used to measure temperatures, species concentrations, and other parameters of importance to the understanding of combustion phenomena.

Work in combustion chemistry improves our understanding of the complex chemical processes involved when fuels burn. The program determines the rates and mechanisms of elementary chemical processes and stresses the close coupling of experiment, theory, and modeling. The modeling of experiments conducted in low-pressure flames yields insight into the dominant chemical reactions involved in combustion. Related efforts address fundamental questions of molecular dynamics and support development of models of processes important to energy-producing technologies. The formation and destruction of nitrogen-containing pollutants, the oxidation of hydrocarbons, and chemical paths leading to soot precursors in rich flames are being studied.

A multidisciplinary program in reacting flows establishes an important link between fundamental studies of combustion chemistry and the real world of practical combustion. This program will increase our understanding of the fundamental interactions between chemistry and fluid dynamics in combustion. Results are being used to improve predictive capabilities for turbulent combustion of hydrocarbon fuels. Experimental studies include flows involving complex fluid mechanics but simplified chemistry. These flows are used to examine primary turbulent transport mechanisms.

Sandia's combustion modeling program is developing

numerical methods to predict the mutual influences of reactions and fluid transport mechanisms. Our current modeling will develop a fundamental understanding of important subprocesses so that future simulations will contain more realistic chemical and physical descriptions of combustion phenomena. We are emphasizing the inclusion of fully detailed chemical mechanisms in advanced combustion models.

### ***Materials Sciences***

Sandia's materials sciences program has three elements: scientifically tailored materials, defects and impurities in solids, and synthesis and processing. The effort in scientifically tailored materials has a strong research theme that supports the development of advanced manufacturing technology relevant to the semiconductor industry.

### ***Scientifically Tailored Materials***

Sandia's program in scientifically tailored materials combines expertise in theory and experimental capabilities in solid-state sciences, atomic-level diagnostics, and materials synthesis and processing to produce new classes of materials for specific applications.

The scientifically tailored materials program explores how capabilities developed in various projects can be used to enhance the competitiveness of US industry. Therefore, we frequently interact with representatives from industry, universities, and the national laboratories to define critical needs and plan collaborative efforts. Many cooperative research and development agreements with industry have grown out of research performed in this program.

Research is ongoing in the physics and chemistry of ceramics synthesis and processing, the use of energetic particle beams for the synthesis and study of materials, high-temperature and organic superconductors, tailored surfaces and interfaces for materials applications, chemical vapor deposition sciences, artificially structured semiconductors, advanced growth techniques and science of epitaxy, boron-rich solids, atomic-level science of interfacial adhesion, and synthesis and processing of nano-sized clusters for energy applications. Considerable synergy exists among these program elements, and most of them have commonalities based on either the science or the use of common synthesis and processing approaches. These commonalities are synthesis and processing, epitaxial materials growth, surfaces and interfaces, energetic particle beams, and high-transition-temperature superconductivity.

The Novel Superconductors Project investigates electronic, structural, and chemical properties of inorganic, high-temperature superconductors and organic superconductors. The goal is to develop a fundamental understanding of the physics of superconductivity in these materials. These studies are integrated with an

extensive synthesis and processing program to produce materials with tailored properties and to develop prototype devices.

Research on compound semiconductor strained-layer superlattice structures and other artificial structures is pioneering, award-winning work. A strained-layer superlattice consists of many thin layers (each a few tens of angstroms thick) of alternating single-crystal semiconductor materials. They typically are made from the more common periodic table class III-V semiconductors, such as GaAlAs, GaAsP, InGaAs, or InAsSb. The multiple thin layers behave macroscopically like new semiconductor materials. Their structures exhibit electronic and optical properties entirely different from those of the constituent materials. The combination of thin layers, lattice strain, and novel patterning allows flexibility in tailoring the properties of these new materials. Sandia is using these new semiconductors to develop high-speed, field-effect transistors, optoelectronic emitters, detectors, novel optoelectronic mirror devices, and broadband light sources.

Chemical vapor deposition sciences explore the basic physics and chemistry of chemical vapor deposition used in the synthesis of materials, particularly thin films. Our research has concentrated on semiconductors and other materials used to make semiconductor devices. However, the understanding gained in this research is applicable to other classes of materials such as coatings resistant to corrosion and wear, high-temperature superconductors, optical materials, and reduced-friction coatings. The work will be extended to these materials.

Basic research in energetic particle synthesis and the science of materials focuses on the interactions of ion, electron, laser, and plasma beams with metals, semiconductors, and dielectrics. This research is exploring materials synthesis and modification with energetic particles to create new materials, determine their properties, and advance materials processing by elucidating fundamental processes using the unique capabilities of energetic beams.

Study of the physics and chemistry of ceramics will develop a fundamental understanding of the atomic and molecular processes that govern the structure and properties of ceramics. The ultimate goal is to improve ceramics processing by gaining a better understanding of the underlying chemical and physical principles.

An ongoing initiative deals with the atomic-level science of interfacial adhesion. Despite the pervasive nature of adhesion problems in materials science and engineering, solutions are almost always the result of trial and error. Significant technological and economic gains can be realized by developing a scientific basis for the phenomena of interfacial adhesion. This will allow the selection of material combinations to provide specific interfacial characteristics. Therefore, this initiative seeks to understand at the atomic level the nature of the physical and chemical interactions that bind solid surfaces together.

The scientifically tailored materials program is investigating atomic-level processes that control the growth and properties of thin-surface layers. This program is also exploring the use of ion, laser, and electron-beam excitation of surfaces during epitaxial growth of semiconductors to control the kinetic energy of surface atoms and extend the range of tailorable epitaxial materials. Additionally, we are examining potential applications of boron-rich solids, which have unique bonding, electronic, and transport properties when used as high-temperature semiconductors. These refractory materials appear promising for use in high-efficiency thermoelectric energy generators and as neutron detectors.

Our newest initiative exploits our recently patented technique for producing novel nanometer-sized clusters with potential applications in energy technologies. Early emphasis will be on inexpensive metal clusters as alternatives to precious metal catalysts for coal liquefaction, control of emissions, and solar photolysis.

#### *Defects and Impurities in Solids (Computational Materials Science)*

Crystalline defects and impurities often determine the properties of solids. Thus, this project seeks to understand and control these imperfections, which are crucial to technological applications of solid materials.

Unique experimental and theoretical tools developed in this program are combined to study structural defects and impurities in solids and on surfaces. The experimental tools are high-resolution transmission electron microscopy, high- and medium-energy ion scattering facilities, video low-energy electron diffraction, surface analytical tools, scanning tunneling microscopy, and low-energy electron microscopy. Theoretical tools developed and employed include quantum chemistry codes, local density approximation/pseudopotential methods, the embedded atom method, and cluster functional methods for large-scale atomistic computer simulations.

These experimental and theoretical capabilities are used to study the following: grain boundaries, interfaces, and surfaces in metal alloys and intermetallic compounds; impurity segregation to these boundaries; and interactions with dislocations, gas bubbles, and defect clusters. Growth of metal layers on substrates is investigated using scanning tunneling microscopy, low-energy electron diffraction, and low-energy electron microscopy. Theoretical models are developed for the nucleation and growth kinetics of thin film layers. High-resolution transmission electron microscopy is used in conjunction with large-scale computer simulations to resolve the dislocation core structure in intermetallic compounds and to analyze the dislocation network configuration and evolution during plastic deformation.

Many of the results from this research are used in

---

concurrent development and engineering projects at Sandia and other national laboratories. In addition, results are disseminated to materials science programs at universities and industrial research and development laboratories via the Sandia visiting scientist program in computational materials science. Collaborations with industry are also carried out via cooperative research and development agreements.

### *Synthesis and Processing Center*

Sandia coordinates activities within the DOE Center of Excellence for the Synthesis and Processing of Advanced Materials. This center is a cooperative venture among the following institutions: Ames Laboratory, Argonne National Laboratory, Brookhaven National Laboratory, Idaho National Engineering Laboratory, University of Illinois Materials Research Laboratory, Lawrence Berkeley Laboratory, Lawrence Livermore National Laboratory, Los Alamos National Laboratory, National Renewable Energy Laboratory, Oak Ridge National Laboratory, Pacific Northwest Laboratory, and Sandia National Laboratories. The center brings together elements of the existing Basic Energy Sciences materials sciences core programs at these laboratories.

The center enhances the science and engineering of materials synthesis and processing to meet DOE's programmatic needs and to facilitate the technological exploitation of materials.

Synthesis and processing are essential elements of materials science and engineering that deal with the assembly of atoms or molecules to form materials, the manipulation and control of the structure at all levels from the atomic to the macroscopic scale, and the development of processes to produce materials for specific applications. Synthesis and processing span the range from fundamental research to technology application.

Basic research in this area ranges from the creation of new materials and the improvement of the properties of known materials to the understanding of such phenomena as diffusion, crystal growth, sintering, and phase transitions. On the applied side, synthesis and processing translate scientific results into useful materials by developing processes capable of producing high-quality, low-cost products. To guide the research and development agenda of the center, an industrial steering group was impeded in the past year.

The center is developing a number of coordinated, focused multilaboratory projects. The selection criteria for technical activities in these projects are

- outstanding science with a clear relation to technology,
- strong existing or potential connections to DOE technologies, and

- strong industrial connections through existing or new cooperative research and development agreements.

Seven projects have been identified and are in the final stages of development:

- high-rate metal forming,
- materials joining,
- nanostructure materials for energy applications,
- in situ polymer composites,
- optimization of magnetic materials,
- processing for surface hardness, and
- high-temperature corrosion coatings.

### *Geosciences*

Sandia's basic research in geosciences encompasses geology, geophysics, geochemistry, geomechanics, and scientific drilling concentrating on the study of dynamic processes in the earth's crust. Focus areas for geosciences research include geophysical imaging of the subsurface, fluid flow through fractures and porous media, experimental rock mechanics, mineral surface interactions, and instrumentation development.

A better understanding of fluid flow through complex media (including fractured rock and soils) will aid DOE programs in waste disposal and isolation, fossil fuel exploration and extraction, and environmental restoration. Sandia is using a combination of numerical and experimental techniques to develop improved models for fluid flow through fractures. Fluid flow through complex geologic media, concentrating on retardation and sorption processes, is also being modeled using lattice gas automata computer codes. An experimental approach to fluid flow characterization is being applied at Carlsbad Caverns. Travel times through fractured limestone from the surface into the cave are being documented in a unique field study of oxygen isotopic data collected from dripwaters. An experimental and analytical study of shear strain localization in rocks examines the mechanics of fracture formation. Sandia is also developing computational algorithms for inversion of electromagnetic data for three-dimensional structure. These codes can identify flow paths and rates below the earth's surface.

Sandia's geochemistry research uses combinations of advanced analytical techniques and computer simulations of molecular interactions to study reactions at mineral surfaces. We have developed a new experimental technique for the measurement of very slow ion diffusion into silicate minerals. Sandia has also pioneered the use of several spectroscopic techniques to study mineral surfaces, specifically dissolution of oxide silicate minerals in the presence of water.

Sandia has significant expertise in developing instrumentation for harsh borehole environments. Current

work includes an advanced instrument for sampling hydrothermal fluids and gases directly from boreholes. This tool will have application in the seafloor, in geothermal exploration holes, and in deep oil and gas wells.

Through the Geoscience Research Drilling Office, Sandia provides lead engineering support for research drilling related to the continental scientific drilling program. Eight drilling projects have been completed. Current efforts are focused on a proposed project to drill into Alaska's Katmai Volcano, which last erupted in 1912.

Geosciences basic research activity develops understanding of geologic processes at a fundamental level. Projects change every two to four years, so the focus evolves to support changes in DOE interests. The program is coupled closely to related technology programs

such as nuclear waste facility design, fossil energy exploration and storage, environmental restoration, and geothermal energy exploration.

### *Engineering Sciences*

Sandia's research in engineering sciences includes several projects that seek to improve our understanding of the physics of fluids. As part of a study of multiphase flow problems, we have teamed with the Massachusetts Institute of Technology and Los Alamos National Laboratory to investigate suspensions of particles in Newtonian and non-Newtonian liquids by developing new theories, conducting numerical simulation, and carrying out experiments. This work has determined the effects of microstructures on the macroscopic properties of suspensions.

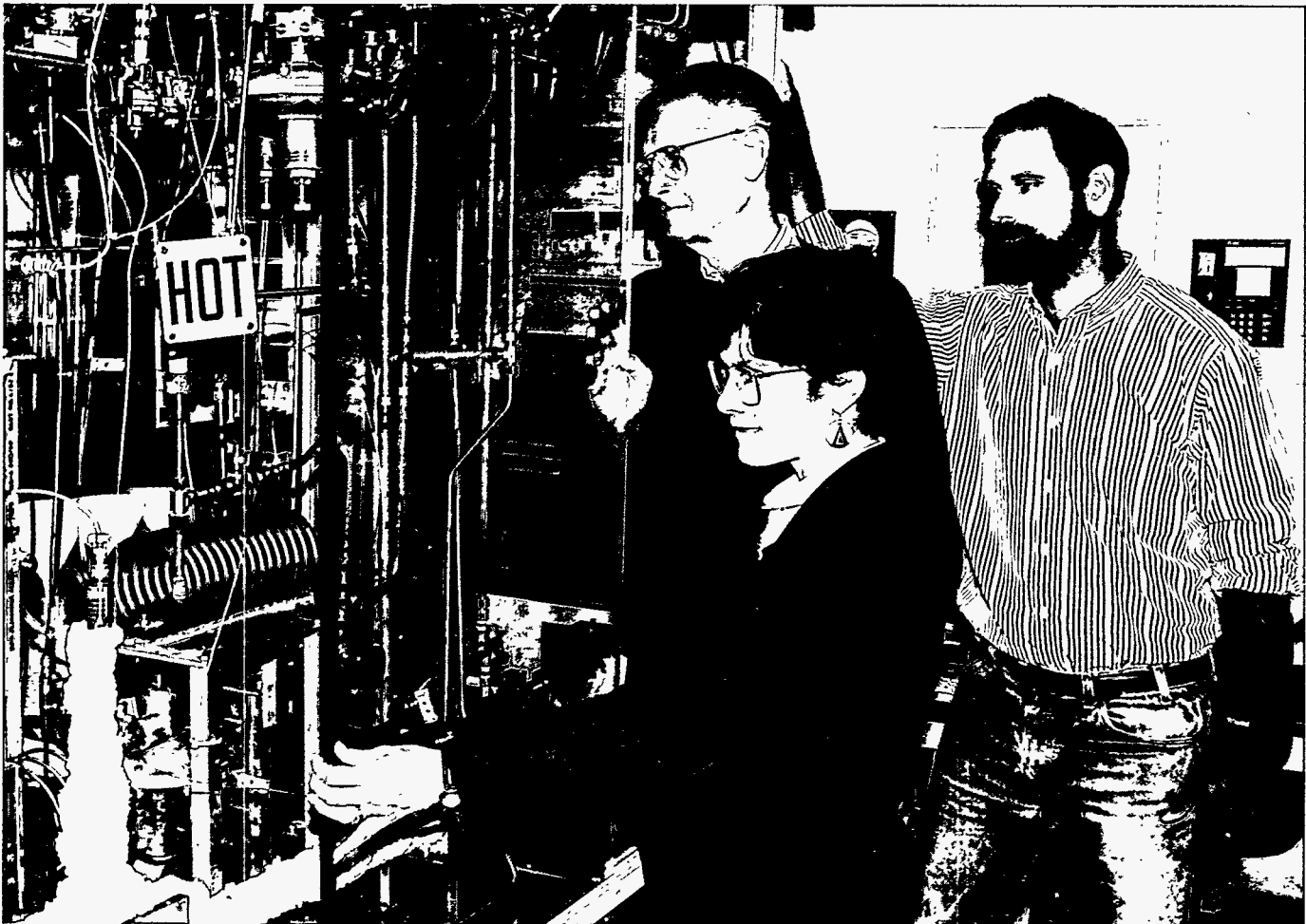

Sandians Ken Tschritter, Mary Clare Stoddard, and Steven Rice view the lab-scale supercritical water oxidation reactor that has potential uses in the field of toxic and hazardous waste disposal.

---

Sandia is also developing and validating a statistical model of molecular mixing in turbulent flow. This model will be used to predict and interpret experimentally observed phenomena. In another effort, we are using optical techniques to investigate the supercritical water oxidation process. This process may be able to destroy toxic and hazardous wastes.

### ***Biological and Environmental Research (KP)***

During the past several years, global climate change has come to the forefront of the world's and the nation's science and policy agendas. Although most scientists agree that man-made, energy-related emissions will cause a greenhouse warming effect, there is uncertainty about the magnitude, timing, and distribution of this phenomenon.

To better understand these issues, the US government has embarked on a global change research program, with DOE as a major participant. Seeking to support DOE in this role, we have drawn on Sandia expertise in remote sensing (from ground, air, and space), field testing, systems engineering, and massively parallel computing to conduct the three program elements described below.

#### ***Novel Instruments and Algorithms for Measuring Water Vapor and Cloud Distribution—Key Uncertainties in Current Climate Models***

Water vapor is the greenhouse gas that plays a key role in cloud formation and in driving atmospheric circulation through the release of latent energy. However, available instruments lack the vertical and temporal resolution required to adequately study water vapor profiles.

Working with the National Aeronautics and Space Administration, we have developed the next generation of a laser remote-sensing technique (Raman light detecting and ranging [lidar]) for providing high-vertical-resolution water vapor profiles during the night and day. We plan to use this technique at one of the DOE cloud and radiation test bed sites to study questions related to the distribution of upper tropospheric moisture—an important but poorly understood issue.

Although Raman lidar is a particularly robust way of measuring water vapor profiles from the ground, different laser techniques are required for the longer ranges characteristic of air and space measurements. To this end, we are developing a miniature-package, water-vapor, differential-absorption lidar for small aircraft or unmanned aerospace vehicles.

Clouds are the other key feedback parameter. Uncertainty in radiation-cloud feedback accounts for most of the uncertainty in predicted temperature rises if atmospheric carbon dioxide doubles. However, it is very difficult to measure even the most basic cloud parameter

(its shape), let alone the microscopic properties that affect the interaction of the cloud with the earth's radiation field. Therefore, we have developed a novel set of algorithms that uses the motion of clouds for extracting geometric information about cloud fields (e.g., cloud base heights) from sets of whole-sky imaging cameras.

We are now using Sandia's experience in massively parallel computing to develop novel ways of fusing these data with complementary data from sources such as satellites and radars to produce true three-dimensional maps. We are also developing a miniature cloud radiometer to provide key radiative properties such as cloud albedo, droplet size, and phase (ice or water). This miniature cloud radiometer will be compatible with both small unmanned aerospace vehicles and small satellites.

#### ***Atmospheric Radiation Measurement Sites***

DOE's atmospheric radiation measurement program seeks to improve the understanding of radiation/cloud interactions by studying these processes at a series of intensively instrumented cloud and radiation test-bed sites. A third site, scheduled to begin operation in FY 1996, will be located on Alaska's North Slope. This locale was chosen because the polar region is the heat sink in the overall climate engine and because the pole has extremes of insolation (six months of day and six months of night), humidity (wet summers and dry winters), and surface albedo (highly reflective snow that melts) that provide a stringent test of the understanding of radiation/cloud interactions. As the manager for this site, Sandia is responsible for planning, implementation, and operation. Also, we work closely with scientists at the University of Alaska to formulate the science plans and coordinate the atmospheric radiation measurement program with other research activities in the Arctic.

#### ***Unmanned Aerospace Vehicles and Small Satellites for Climate Studies***

Although the initial phases of atmospheric radiation measurement emphasized ground-based measurements, it was recognized from the start that air- and space-based measurements are needed to provide information about radiative fluxes, water vapor profiles, and cloud top properties in the atmosphere and to extend the range of these measurements to regional and global scales.

Conventional aircraft and satellites can meet part of these needs but not all of them. For example, aircraft currently cannot operate for multiple days at the tropopause. DOE has proposed major initiatives that use a new generation of small unmanned aerospace vehicles, small satellites, and associated miniature instruments to fill these key measurement gaps. DOE has selected a Sandian as technical director and coordinator of this multilaboratory/multiagency program. Sandia's role includes program formulation and direction, payload integration, and instrument development.



---

In less than six months, Sandia scientists developed and integrated a baseline radiometric payload for an unmanned aerospace vehicle. On its engineering test flight, this payload worked flawlessly, yielding publishable scientific data—the first ever climate-relevant measurements from an unmanned aerospace vehicle. In succeeding phases of the program, we plan to fly at higher altitudes using unmanned aerospace vehicles supplied by US industry, demonstrate the ability to use multiple vehicles for measuring atmospheric profiles, and develop additional instruments to measure cloud and water vapor properties.

## **Office of Science Education and Technical Information**

The Sandia Education Outreach consists of an extensive, interrelated set of programs supporting scientific and technical education for students, teachers, and faculty. Each program is designed to improve scientific and technical literacy and to increase the number of scientists and engineers from historically underrepresented groups in support of DOE's goal of a technically literate and culturally diverse work force. The programs are designed to encourage students interested in a career in science or engineering, beginning in grade school, continuing through twelfth grade, and then through college undergraduate and graduate programs. Summer research programs are part of the postsecondary through graduate student activity and are designed to support Sandia's Affirmative Action Program by promoting the hire of qualified individuals from these programs. Outreach programs also exist for teachers at all educational levels from grade school through university faculty.

These efforts are funded by DOE through Defense Programs and the Office of Science Education and Technical Information, which administers the DOE initiatives.

## ***Science and Mathematics Education Outreach Programs***

Sandia's outreach efforts are described below, under the general headings of pre-college programs, programs for college and university undergraduate students, programs for university graduate students, and programs for college and university faculty.

### ***Pre-College Programs***

#### ***Science and Mathematics Education Enhancement for Students in Grades 1 through 12***

The Science/Math Carnival makes learning fun for

elementary school students and encourages educators to teach science and mathematics by offering up to fourteen hands-on activities. The carnival is staffed by 180 Sandia/California volunteers and in a twelve-month period typically visits about eighty schools and contacts 1,100 teachers and 35,000 students.

The Summer Science Enrichment Program developed by a Sandia/California engineer serving as a science advisor in the Oakland schools was implemented in four Oakland elementary schools. This program was aimed at students with low self-esteem, who lacked motivation in the classroom, and who belonged to traditionally underrepresented groups in science. An introductory evening of hands-on science activities for the families of the twenty-two students and handout materials encouraged parents and children to enjoy science exploration at home. Parents were also invited to participate in as many of the daytime sessions as they could. This program emphasized hands-on cooperative experiences with attention toward integrating the arts, math, and literature in a science base. The program was structured around a hands-on science curriculum developed at the Lawrence Hall of Science.

The After-School Science Club was initiated for Oakland middle school students who were significantly below grade level in reading and critical thinking skills. Sandia/California Education Outreach developed the basic concept and format for the club, secured funding, and developed ideas for student summer projects. During the once-a-week, hour-long sessions, students engaged in a wide variety of experiments and activities, including selected environmental science modules developed by Science Education for Public Understanding at the Lawrence Hall of Science. Evaluation demonstrated that the forty student participants improved their skills, showed increased interest in science, and made progress in developing self-esteem.

The New Mexico State Science Olympiad is an academic interscholastic competition that increases student interest in and enthusiasm for science education. Middle and high school students participate in hands-on activities in almost every aspect of science. Competing at regionals, more than one thousand students from across the state vie for the opportunity to be one of fifty schools to participate in the state finals. Winners of both the middle school and high school divisions represent New Mexico at the national finals. The Science Olympiad is an opportunity for competitors to excel in scientific thinking and applied science, individually or on a team. Under the guidance of approximately 250 volunteer coaches throughout the state, these students balance knowledge of facts, concepts, processes, skills, and applications while competing in all areas of science. Sandia has sponsored the New Mexico State Science Olympiad for the last three years, providing support and advice. The state competition involves more than 750 students, 125 coaches, one hundred event supervisors, an eight-member advisory



Two students from the College Bound Program at the Southwestern Indian Polytechnic Institute visit Sandia's Virtual Reality lab. Sandian Roy Lee hosted the students, who also toured the Sandia/California facilities while in the Bay area.

board, one state coordinator, and one state director. The Science Olympiad is important because it touches so many students.

The Expanding Your Horizons Program sponsored by the Women's Math/Science Network, a national organization, encourages junior high and high school girls to explore many scientific disciplines and numerous science and technology career options. The program is a day-long career conference that regularly attracts standing-room-only crowds of students. Expanding Your Horizons encourages girls to study math and science in school and to consider careers in mathematics, science, and technology. Sandia/California coproduces two Expanding Your Horizons conferences each year.

*Breaking Through: Women in Science* is a thirty-minute documentary videotape featuring the lives of women from Sandia/California, Lawrence Livermore National Laboratory, and the Jet Propulsion Laboratory. This video is intended to inspire girls in junior and senior high school to pursue careers in science and technology. *Breaking Through* has been featured on public television and has received honorable mentions by the Pacific Mountain Network and by American Women in Radio and Television, Inc. A fifteen-minute version is being produced for use where appropriate.

In the College Bound Program at the Southwestern Indian Polytechnic Institute, New Mexico and California Sandians work closely with the institute to provide ninth-through twelfth-grade students the skills and motivation to remain in school and to enter college in a math-, science-, or technology-based field. In 1993, eighty students from fifteen tribal groups participated in the six-week intensive residential summer program at the institute in Albuquerque, New Mexico. Students attended

classes, workshops, and field trips to increase their science, math, and communication abilities and improve their problem-solving skills. The College Bound Program for the Southwestern Indian Polytechnic Institute also collaborates with the Rural American Indian Science Enrichment Project, a teacher-enhancement program funded by the Bureau of Indian Affairs.

The DOE High School Science Student Honors Program offered for two weeks during the summer is designed to introduce high school honor students in science to a diverse range of engineering research topics. Each student is selected by his/her state, providing approximately fifty student participants. One goal of this program is to cultivate relationships with these outstanding students and to enhance Sandia and other DOE national laboratories' future technical work force. For the summer of 1994, nine of the students who participated in the program in 1993 will return to Sandia for summer employment.

The High School Speaker's Bureau provides high school teachers with speakers from Sandia to talk about specialized math and science topics and offer career information. Speakers from this program contact approximately 550 students per year.

The New Mexico Supercomputing Challenge provides an opportunity for more than five hundred high school students to design and run computer programs. Sponsored by a number of state organizations, the program involves young persons in mathematics and computation science projects, then offers scholarships to promising students to attend New Mexico universities. The program fosters student creativity in applying computational solutions to scientific problems. Open to all secondary schools, this statewide competition brings students together in problem-solving teams. Experts from national laboratories and research universities coach students in supercomputer use. Sandia provides training, supercomputer time, and coaches for the teams.

As part of the DOE National Science Bowl, Sandia hosts regional competitions for high school students in New Mexico and California. An average of twenty-four high school teams from New Mexico and fifteen from California participate annually in this science, mathematics, and technology question-and-answer tournament. Sandia is represented by each winning team at the national finals held in Washington, DC. Nationwide, the program involves more than twelve thousand students from two thousand high schools.

The School Partnership Project recruits, trains, and equips scientists and engineers to conduct motivational hands-on science activities with students to make science more understandable, make science principles interesting and relevant, and foster positive impressions of science and scientists. Approximately thirty-five members of the Sandia technical staff develop and conduct monthly science enrichment activities with approximately two thousand students at six Albuquerque schools in direct

---

support of current science curriculum topics. These activities are designed to use resources to which teachers would not normally have access (such as liquid nitrogen, x-y plotters, and oscilloscopes). In addition, Sandia provides program ideas and technical assistance to local organizations involved in informal science education. Sandia also actively shares the principles and activities that have proven successful in the local program with other groups and organizations to promote national support of science education.

Sandia offers three supplementary student projects: Hands-on/Minds-on Technology for African-American students, the Dream Catcher Science Program for American Indian students, and the Hands-on Science and Engineering Program for Hispanic students. These classes are offered after school for several weeks during the fall and spring semesters. Classes are taught principally by Sandia employees from the Black Leadership and Outreach Committee, the American Indian Outreach Committee, and the Hispanic Leadership and Outreach Committee. Approximately 335 students participate in these supplementary projects.

### ***Teacher Training and Curriculum Development for Teachers of Grades 1 through 12***

Adventures in Supercomputing is a DOE-funded effort to bolster computer literacy and scientific understanding among teachers. At no cost to schools, Sandia and two other national laboratories offer participating schools the use of high-performance computers, software, networks, and expertise. A two-week summer institute at Sandia for New Mexico teachers introduces instructional materials for teaching computational science. It also demonstrates software applications and examples of high-level tools for modeling scientific problems.

The Bay Area Science and Technology Education Collaboration is a partnership that includes Sandia/California, three other bay area DOE laboratories, the Oakland Unified School District, local businesses, industries, and civic groups working together to improve mathematics, science, and technology education in the Oakland schools. Sandia/California is a full partner on the collaboration board, participates on collaboration subcommittees, and assists with curriculum development. Sandia's one-week Summer Teachers Institute helps Oakland teachers gain a better understanding of the basic science concepts taught through the Science/Math Carnival. Several one-day, Sandia-sponsored workshops each year prepare Oakland teachers to utilize selected science modules and provide teachers with kits for classroom use.

The Bureau of Indian Affairs and Rural Schools Science Advisors Program works with eighty schools in five educational agencies, ten public school districts, and one private school system to provide teacher enhancement in science and mathematics instruction.

Approximately 450 teachers have direct contact with their science advisor on a regular basis throughout the academic year. In addition, more than seven hundred teachers annually attend in-service workshops conducted by the program. More than nine thousand students are impacted as a result of teacher involvement in the program. In the Rural American Indian Science Education Project, Sandia scientists, engineers, and technicians serve as long-distance consultants to science and mathematics teachers in rural and American Indian schools. Sandia personnel provide guidance on classroom experiments and examples of state-of-the-art, practical, scientific applications. The Sandia employee assigned to a school visits it once each semester and interacts with faculty from the school weekly by phone or teleconference. Schools currently in the project are located in Arizona, Maine, New Mexico, North Carolina, North Dakota, South Dakota, Oregon, and Oklahoma.

The DOE-sponsored Teacher Research Associates Program provides summer opportunities in scientific and engineering research for outstanding high school science and mathematics teachers. Five high school teachers have been selected to study at Sandia for eight weeks during the summer of 1994. The teachers are from New York, New Jersey, Louisiana, California, and New Mexico. These teachers receive a stipend of \$550 per week, \$1,000 for housing and travel expenses, tuition up to \$200 for academic credit, and a follow-on activity award of \$250 times the number of first year teacher research associates at a given facility.

The Gaining Access to Natural Abilities in Science (GANAS) Summer Teacher Enhancement Program develops teacher skills in alternative methodologies that engage all students in the excitement of science and math. The program brings together science and math teachers, engineers, and trained personnel to expand teachers' knowledge of current science topics. The program provides teaching methodologies to middle- and high-school teachers, acquaints teachers with national math and science standards, and provides an opportunity for teachers and scientists/engineers to collaborate in designing classroom activities and lesson plans based on the standards. The 1993 program trained fifty teachers, who will use their new skills/materials to teach approximately fifteen hundred students at each middle or high school per year.

The Math through Applications Program improves students' mathematics competency and shows them how math relates to everyday life. The DOE/National Science Foundation-funded program is a collaboration among Sandia, the Institute for Research on Learning in Palo Alto, California, and the School of Education at Stanford University. The program applies real-life perspectives to math projects for sixth- through ninth-grade students in inner-city schools. Instruction modules contain experimental demonstrations, computer simulations, and computer programming. At a summer institute, hands-on

projects show inner-city teachers how mathematics is used in real-world applications.

The Science Advisors Program enhances the mathematics, science, and engineering education of large numbers of students by helping teachers become more knowledgeable about and comfortable in teaching those subjects. The project assigns an engineer, technician, or scientist to support the faculty at an elementary or middle school one day a week for an entire school year. Currently, about two hundred Sandians and 178 schools in New Mexico participate. One unique benefit of the Science Advisors Program is that it does not target a particular group of students, but benefits all children.

With Sandia's support, the Portable Science Advisors Program has expanded to Las Cruces and Carlsbad, New Mexico, and to El Paso, Texas. These programs are modeled after the Albuquerque and New Mexico Bureau of Indian Affairs Science Advisors programs but are implemented

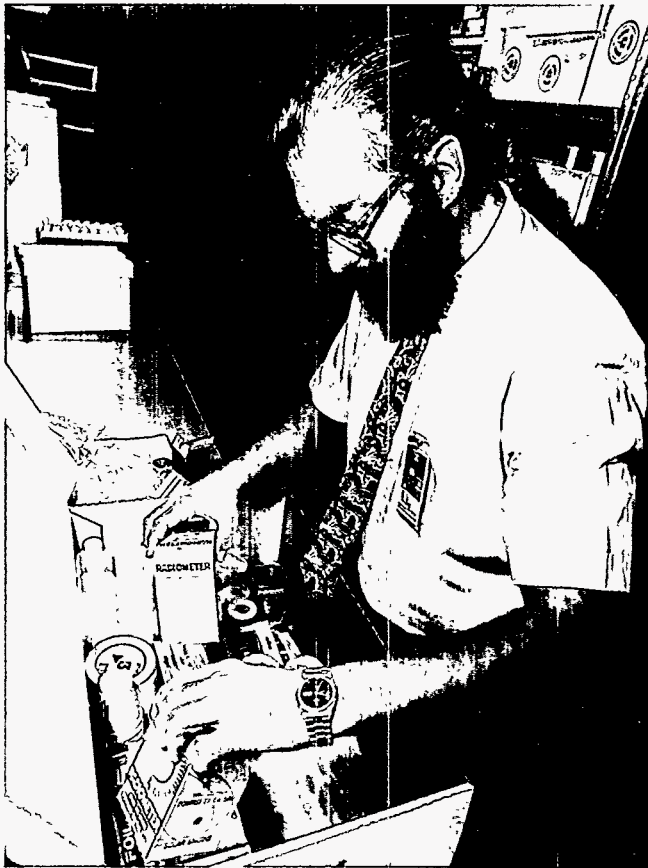

Gabriel Gawrada restocks one of the more than 100 science kits that are used in Sandia's Science Advisors Program. The kits are used by more than two hundred Sandia scientists who spend one day a week demonstrating scientific subjects to elementary and middle school students as part of the Science Advisors Program.

through a partnership of area businesses. Sandia provides guidance for the design of each program, assistance in establishing resource centers, technical assistance, and workshops for science advisors and teachers.

The Science Education for Public Understanding Program is a collaboration between Sandia and the Lawrence Hall of Science. This program develops middle school strategies for teaching science with a focus on environmental issues. The program provides teachers with a model for hands-on instruction and all materials needed for performing the experiments in a class of thirty-two students. Students working with the program modules collect and process scientific evidence and use it to make decisions. As a result they begin to appreciate both the power and limitations of science.

Science Seminars are offered through a partnership between Sandia/California and the Livermore Valley Unified School District. The seminars are open to all first-through twelfth-grade teachers in the area, and describe the science behind the headlines. Some of the lectures in 1993 were "How Windmills Suck the Energy Out of the Wind," "Lighting Up the Sky with Laser Guide Star," "Protecting the Earth with 'Green' Batteries," "Lasers Are So Simple We Can Use Them Anywhere," "Solar System Astronomy in the Classroom," and "Is The Earth Becoming a Greenhouse?"

The Summer Teacher-Enrichment Program provides an opportunity for middle- and high-school teachers to upgrade their knowledge and skills through practical work experience in areas related to their educational specialties and through exposure to programs and projects at Sandia.

The Teacher Opportunities to Promote Science Program was developed and implemented by Sandia and Los Alamos national laboratories as a teacher enhancement program for middle school teachers in rural areas of New Mexico. Through participation in this program, teachers improve their teaching skills and ultimately serve as role models and mentors to their colleagues. Sixth-, seventh-, and eighth-grade teachers participate in an intensive three-year training program in science. The teachers attend a three-week summer institute, participate in three follow-up workshops during the academic year, and receive visits to the classroom by program staff. Additionally, participants have the opportunity to establish a student/parent component at their schools. One hundred participants (fifty at each laboratory) have shared their expertise with approximately six thousand students. Participants also facilitated workshops for teachers in their districts and at state and national conferences. Approximately seven hundred families have been impacted through the student/parent component.

The Science Understanding Promotes Environmental Responsibility Summer Institute for middle- and high-school teachers presents the science behind such environmental issues as risk assessment and management, groundwater cleanup, plastics, and hazardous

waste cleanup. The institute offers presentations by Sandians and outside speakers, field trips, and laboratory work. Teachers are trained using the Science Education for Public Understanding Program environmental science modules developed by the Lawrence Hall of Science. Another important thrust of the institute is training leadership teams who spearhead reform in their schools through teacher in-service workshops, by encouraging cross-curricular teaching, and by deploying alternative teaching and assessment strategies.

The Leadership Academy for Science Education Reform is a multiyear workshop for elementary school teachers being planned in collaboration with the California Science Implementation Network, the National Science Foundation-funded State Reform Program for elementary schools, and the Lawrence Hall of Science. The National Science Foundation's National Teacher Enhancement Project is partially funding this three-year program at \$100,000 a year. The academy's goal is to be a resource for California's educational reform movement by creating a group of lead teachers who will serve as mentors for their colleagues, provide credible role models of good science instruction, and lead educational reform in their districts. The program brings together the strengths and long-term commitment of schools, scientific communities, and the California Department of Education. Each year, the same group of teacher/leaders will spend three weeks in July and six days of the school year strengthening their science knowledge, pedagogy, assessment skills, and leadership abilities. The academy's program is based on a teaching/learning model that parallels the way scientists acquire knowledge and solve problems. The academy uses the unique resources available at Sandia by immersing the participants in research conducted at the laboratory, where the teachers explore, investigate, and participate in hands-on science. By inviting teachers to join Sandia scientists and engineers in solving problems, DOE provides an opportunity for them to explore what it means to use the scientific method. The partnership with the Lawrence Hall of Science will allow teachers to work with educators in applying their hands-on science experience in their classrooms. The involvement of the California Science Implementation Network brings the strength of the State Department of Education to these reforms in science instruction.

### ***Programs for College and University Undergraduate Students***

The American Indian Community College Initiative develops accredited, two-year technology programs at the Southwestern Indian Polytechnic Institute in Albuquerque, New Mexico. This initiative is developing a two-year curriculum that will mesh with both the Southwestern Indian Polytechnic Institute and Haskell Indian Nations

University in Lawrence, Kansas. The development program will use retired Sandia and university personnel to formulate and teach new courses, and will provide release time for existing faculty to obtain the advanced degrees required for accreditation.

The Cooperative Education Program provides opportunities for undergraduate students to acquire laboratory experience along with college studies. Work assignments are carefully matched to individual interests, and the technical challenge increases as a student's education advances.

The Historically Black Colleges and Universities Program is sponsored by DOE. Sandia is an active participant, offering summer employment to exceptional junior, senior, and graduate engineering and science students. Students earn academic credit for participating in research activities and documenting those activities in a technical report.

The Minority Engineering Program provides advisors, tutors, and mentors for Hispanic and American Indian engineering students at the University of New Mexico. This program develops the survival skills of undergraduate minority students to increase their chances for success within an engineering program. The following strategies are used to improve student performance:

- clustering minority students in mathematics, chemistry, and physics classes,
- forming study groups in engineering mathematics, physics, and chemistry courses,
- providing a freshman orientation course,
- providing scholarships for Minority Engineering Program students, and
- providing a study center for Minority Engineering Program students.

Using the freshman class the year before the Minority Engineering Program began (fall 1989) as the baseline, freshmen to sophomore retention rates have increased significantly. Detailed analysis shows that minority engineering students participating in study groups have higher grade point averages than other students taking the same courses.

The Outstanding Student Summer Program offers engineering and science majors from the junior year through graduate studies an opportunity for summer work in a laboratory environment. Approximately 110 students will participate in the program during the summer of 1994.

The Science and Technology Alliance was created in November 1987 to increase the number of African Americans, American Indians, and Hispanics in the scientific and engineering programs of DOE, other government agencies, and private industry. The DOE-sponsored alliance assists

participating universities in upgrading their infrastructures and increasing collaboration with national laboratories. Sandia is the lead laboratory in a consortium that includes Los Alamos National Laboratory, Oak Ridge National Laboratory, the Fundación Educativa Ana G. Mendez in Puerto Rico, New Mexico Highlands University, North Carolina A&T State University, and the Montana consortium. The Montana consortium, the newest alliance member (November 1993), is composed of three tribal colleges (Salish Kootenai College, Fort Peck Community College, and Little Bighorn College) and a four-year private college (Rocky Mountain College) in Billings. The Georgia Institute of Technology is an affiliate member, providing programmatic counsel and graduate opportunities. AT&T and Martin Marietta are the first industry participants.

The Summer Employment for Minority Youth Program provides summer employment for underrepresented youth who are high school juniors and seniors or university freshmen and sophomores. The program provides real-world work experience in technology fields. The program targets only students with mathematics and science interests and imposes no financial criteria. In the summer of 1993, 106 students participated in the program and 118 students are expected to participate during the summer of 1994.

The Summer Employment Program for Native Americans recruits undergraduate and graduate students nationwide who are enrolled in math, science, engineering, technology, or computer science programs. For the summer of 1994, there will be approximately twenty students in the program. Opportunities also exist for

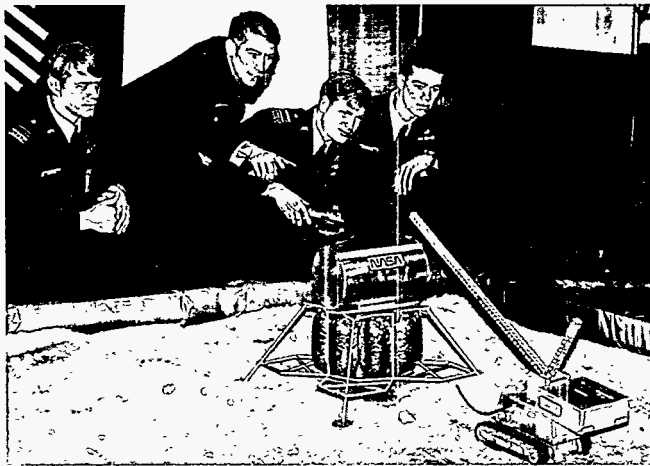

A team from the US Air Force Academy participated in the Lunar Shelter Student Contest hosted by Sandia during the International Space Conference in Albuquerque. The cadets had to maneuver the remote-controlled tracked vehicle to do a number of tasks.

students to participate in a cooperative program for a maximum of twenty hours a week during the academic year.

The first Lunar Shelter Student Contest was conducted as part of Space 94: The Fourth International Conference and Exposition on Engineering, Construction, and Operations in Space, which was co-located with the Conference and Exposition on Robotics for Challenging Environments at the Albuquerque Convention Center from February 26 through 28, 1994. This competition was sponsored by Sandia's Education Outreach Department and the National Aeronautics and Space Administration. The objective of the contest was to telerobotically construct a model lunar base. Specific tasks included unloading, transporting, positioning, and covering a model lunar habitat. This competition exposed students to real-world problems associated with project planning, budget constraints, system integration, and teamwork. Four universities were invited to the competition: Texas A&M University, the University of New Mexico, North Carolina State, and the Air Force Academy. The University of New Mexico withdrew before the competition began. Each team was composed of four students and a faculty mentor to assist with the plan, design, and fabrication of the habitat components and construction equipment. All of the teams spent several months designing, testing, and integrating various components into a cohesive robotics unit. Contest organizers and conference attendees were exposed to some innovative solutions to problems that will be encountered during the construction of a real lunar base. The Air Force Academy took the first place trophy, Texas A&M placed second, and North Carolina State University placed third.

### *Programs for University Graduate Students*

The Graduate Engineering Internship Program provides opportunities for University of New Mexico graduate students in engineering and science to acquire meaningful laboratory experience by alternating work and academic experience. It is available during the academic year.

The National Consortium for Graduate Degrees for Minorities in Engineering is composed of university and industry members. The consortium provides opportunities for students from underrepresented groups to obtain master's degrees in engineering through a program of paid summer internships and financial aid. This year Sandia is sponsoring four students in master's degree programs. Support is being sought to fund two PhD candidates for the 1994-1995 academic year.

The One-Year-on-Campus Program helps meet Sandia's desire to increase the number of underrepresented engineers and scientists. Holders of a bachelor's degree who have a high grade-point average are recruited and

---

allowed to attend graduate school full-time for a year. In specific disciplines where Sandia has difficulty recruiting persons with a master's degree, persons with a bachelor's degree are hired and allowed to attend school full-time for two years to complete their master's degree. Currently there are seven participants (five from Sandia/New Mexico and two from Sandia/California). The 1993-1994 participants attend the following universities: University of New Mexico, New Mexico State University, Georgia Tech, Cornell, Stanford, and the University of Southern California.

Sandia's Postdoctoral Internship Program hosts postdoctoral students in areas of research where Sandia expertise or facilities provide a good match for students' interests. The program encourages a continuous flow of top scientists and engineers into Sandia.

### *Programs for College and University Faculty*

The Western Partnership for Environmental Technology Education develops and enhances environmental technical programs at community colleges by sharing technical resources from federal laboratories, state agencies, and private industry with the academic community. Sandia/California manages the partnership's faculty internship program, an eight-week, in-depth opportunity for college instructors to study hazardous-waste management practices at DOE, the National Aeronautics and Space Administration, the Environmental Protection Agency, and US Navy facilities. In 1993, thirteen interns were placed at ten sites.

The Sandia University Research Program provides research funds for faculty members at the three PhD-granting institutions in New Mexico. The program is limited to new faculty and is usually the first funding they receive. This seed money is sufficient only to fund one graduate student, pay the summer salary of the faculty member, and reduce the teaching load during the academic year. Funding is limited to research of interest to the sponsoring Sandia organization for a maximum of two years.

The Sandia University of New Mexico Distinguished Professor Program provides Sandia technical staff to teach courses at the University of New Mexico and assist in the development of collaborative research projects. The position is fully funded by the University of New Mexico and Sandia staff members are provided with office space and the title and responsibilities of a visiting professor.

The Sandia/University of New Mexico Joint Appointments Program seeks new faculty members for positions in fields important to both the University of New Mexico and Sandia. Appointees devote half-time to teaching at the university and half-time to research at Sandia for two years.

The University Faculty Summer Employment and Academic Year Sabbatical programs attract outstanding professors from universities nationwide. Participating

individuals make meaningful contributions to Sandia's technical expertise. At the same time, they have the opportunity to do mission-oriented work. These professors are considered temporary employees who work on research and development projects specified by Sandia organizations.

### **Work for Other Department of Energy Locations, Contractors, and Offices**

Sandia performs work for other DOE elements as requested to support programmatic and institutional requirements. These elements may include field operations and facilities of the nuclear weapons complex, as well as special programs administered by DOE Headquarters.

Sandia assists other DOE locations with facility safeguards and security. We have a broad base of experience in this field as it relates to nuclear materials and operations.

Sandia developed and delivered the device transport vehicle to DOE's Nevada Operations Office for use at the Nevada Test Site. This vehicle substantially upgrades the safety and security of nuclear explosive test devices from their point of assembly at the Nevada Test Site to their point of emplacement for detonation.

Sandia also developed a tool called the analytic system and software for evaluating safeguards security. This tool has been used at many DOE sites to help identify security needs and the adequacy of upgrades.

Sandia is assisting the Portsmouth Gaseous Diffusion Plant in the design and implementation of their alarm communications and display system. We are collaborating with Los Alamos National Laboratory on an integrated safeguards system for Argonne National Laboratory-West that will provide physical security and materials accounting features. We are also consulting with a number of other sites, including Savannah River, Y-12, Pantex, Allied-Signal, Mound Laboratories, Lawrence Livermore, and Bettis Naval Reactors.

We are playing a major role in the waste energy conservation program sponsored by DOE's Office of Waste Reduction. This program is an alliance of DOE, Sandia, Los Alamos National Laboratory, and industry to stimulate the development and transfer of waste reduction and energy saving technologies to industry.

## Work for Non-DOE Entities (Work for Others)

Approximately 25 percent of Sandia's programmatic effort is work for agencies other than DOE and about 80 percent of that effort is for DoD. These programs exercise and strengthen the capitalized resources we maintain for the nuclear weapons programs. They also make cost-effective use of existing federal investments for technological needs in areas such as conventional defense, strategic defense, treaty verification, law enforcement, microelectronics, manufacturing, transportation, biomedical engineering, and space. The technology base developed through our work for DOE has established expertise and capabilities not usually found in industry or in other government agencies. Therefore, opportunities to contribute technological solutions to agencies other than DOE help solve national needs, benefit the supported agencies through leverage of multiagency funds, and help maintain our abilities to perform DOE missions.

Before undertaking a work-for-others project, we ascertain that no interference with DOE weapon programs will result and that the work is not in direct competition with the domestic private sector. Acceptable projects involve problems of national importance that reasonably match our DOE missions and capabilities and are feasible in terms of program goals and availability of required assets. We are allowed to undertake only work for which we have special capabilities as a consequence of our technical expertise or facilities. Many of our work-for-others sponsors utilize Sandia's strong systems integration capabilities for rapid prototypes to quickly identify and resolve critical technical issues. Often, this work is completed jointly with or transferred to private industry, requiring our involvement only so long as needed to meet the sponsor's objectives.

## Department of Defense

### Air Force

Sandia has long collaborated with the Air Force on directed energy weapons research and on developing satellite instrumentation, weapon subsystems, and physical security systems.

We are continuing to support Air Force satellite programs with special flight instrumentation systems, sensors, and ground processing capabilities to meet unique requirements. These activities provide sensors and data processors for satellite tactical and surveillance missions and provide ground-based calibration and data

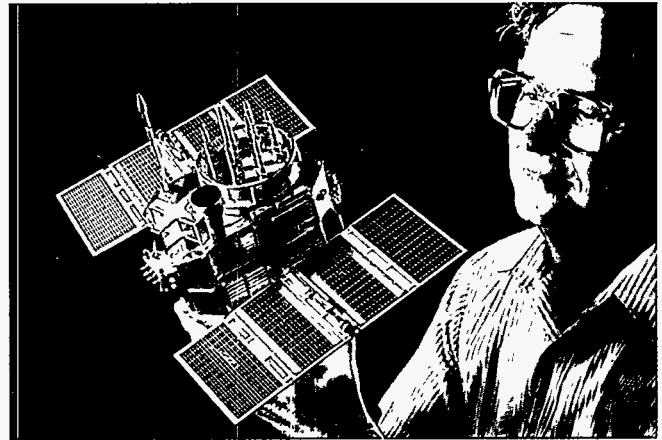

Sandian Paul Phipps holds a scale model of one of the 24 global positioning satellites (GPSs) in earth orbit. Each GPS carries a global burst detector that contains Sandia-designed optical sensors and data handling processors. The detectors have worked flawlessly for more than a decade.

processing systems to support these missions. A nuclear burst detection sensor is being developed for the Air Force Space and Missile Systems Center that will work in conjunction with the DOE-funded global burst detector deployment on the global positioning system satellite constellation.

Sandia has developed and installed an integrated correlation and display system for processing data from nuclear detonation sensors. We are developing a mobile version of that system called the ground nuclear detonation detection system terminal. Data systems that support both space- and ground-based detection systems are being developed. We are also developing a distributed network of computer systems to monitor subsurface (underground and underwater) phenomena.

In programs for the protection of space assets, we are developing a laser sensor system and a ground station capable of detecting, characterizing, and reporting laser irradiation directed toward a satellite from ground-based or airborne sources. Sandia has achieved a state-of-the-art capability in the design of high-data-rate, survivable, radiation-hardened, integrated communication systems and is in the process of codifying the design rules for such devices for the benefit of defense electronics manufacturers.

Sandia has unique technical capability in the area of mobile command and control centers that can survive in a nuclear environment. We are engaged in a proof-of-concept project for a transportable, survivable, multishelter command center for the Strategic Command and the Strategic Target Planning Staff. Similar work will produce a prototype command center to meet the requirements for mobile, survivable command centers for



the North American Aerospace Defense Command and the United States Space Command.

Sandia and the Air Force Central Inertial Guidance Test Facility are developing a small, high-accuracy, ring laser gyroscope inertial navigation system. This system is being developed for maneuvering reentry vehicles, and will also be used by the Air Force in a scoring system to evaluate other missile guidance systems.

We are working with Phillips Laboratory to support its Ballistic Missile Technology Program with maneuvering, guidance and control, kinetic energy penetrators, and earth penetration warhead technologies based on our earlier work in reentry vehicles.

We are also working closely with Phillips Laboratory to support the DoD thermionic space reactor program. The thermionic system evaluation and test program involves nonnuclear testing of a Soviet TOPAZ II reactor. We are developing the test schedule and providing the test director and technicians. We are also creating computer software that can predict test results and the response of thermionic space reactor systems during various transient conditions. Finally, we provide technical expertise to assess the potential of various thermionic space reactor designs.

Sandia is a major contributor to the Phillips Laboratory high-power microwave research, development, and testing program. We are developing compact, narrow-bandwidth sources and high-power broad-bandwidth sources. These sources are used in tests for collecting susceptibility data and evaluating system hardening techniques. We contribute to system studies and mission analysis.

Activities in support of US Air Force physical security programs include the following: systems design and development of weapon storage vaults; intrusion detection; communications; assessment technology; and participation in evaluating the needs and application of these technologies to specific sites. Air Force organizations with whom these activities are undertaken include the Electronic Systems Division of Systems Command, Electronic Security Command, Tactical Air Command, US Air Force Europe, and other smaller organizations. These efforts draw directly on and supplement our experience in providing security technologies for the DOE nuclear weapons complex. We have successfully transferred some of these technologies to private industry and continue to work with industrial partners to improve their security equipment.

## Navy

Building on the successful relationship with the Navy that produced integrated arming, fuzing, and firing systems for the Poseidon/Mark 3 and Trident/Mark 4 reentry bodies, Sandia developed a highly integrated arming, fuzing, and firing system for the Trident/Mark 5

weapon program, which provides fuzing options to enhance effectiveness against hardened targets. The first production unit was completed in 1988 in time to support the Navy's initial operating capability in 1989. Completion of production of the arming, fuzing, and firing assembly is expected in 1994.

Sandia supports the submarine-launched ballistic missile strategic capabilities enhancement program (sponsored by the Navy Strategic Systems Project Office, Reentry Branch) by developing and characterizing general purpose/precise trajectory reconstruction flight instrumentation. Sandia's experience in navigational guidance and control with radiation-hardened microelectronics will be used to develop a broad mission telemetry package. In addition, we are providing the following: alternative submarine-launched ballistic missile warhead research; design, lethality, and effectiveness analysis; and test services. These efforts utilize Sandia's experience in

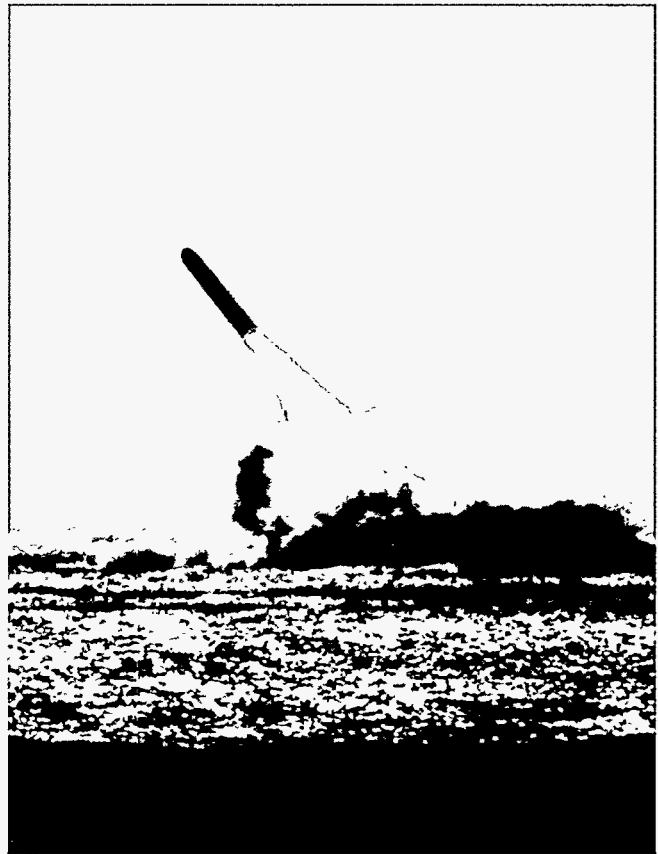

Sandia provides engineering services and technical evaluation to the Navy for its Trident II Mark 5 reentry body warhead. Sandia also supports the Navy's submarine-launched ballistic missile strategic capabilities enhancement program.

---

engineering and computation for nuclear weapon development, applying it to a related area that could have significant strategic importance.

We also provide engineering services for and technical evaluation of the aging characteristics of a limited number of arming, fuzing, and firing assemblies for the Trident II/Mark 5 reentry body and of flight performance of stockpiled Mark 4 and Mark 5 reentry body assemblies. This work involves periodic testing and inspection of war reserve material and emphasizes the detection and evaluation of any degradation that might change the functionality, reliability, and safety of a component or system.

As a result of Sandia's forty years of experience in weapon systems design, maintenance, and surveillance, the United Kingdom and DOE requested Sandia's support for the UK's trident-like weapon system program. Engineering services were requested for the development, evaluation, production, and stockpile surveillance of the UK's reentry body system.

We are also working with the Navy Special Projects Office to develop and test unique reentry body instrumentation options that will provide the Navy with low-cost trajectory measurement systems consisting of an inertial measurement system updated by a Global Positioning System receiver.

Materials modeling and structural analysis by Sandia in earlier weapon development work for DOE and DoD are being applied to Navy problems of assessing the lethality of conventional warheads against various targets. This work for the Naval Underwater Systems Center uses analytical and experimental techniques to determine the onset of material failure and the propagation of damage under short-time, high-energy deposition.

Sandia has performed reimbursable work in support of Marine Corps expeditionary force capabilities. Drawing upon our expertise in sensor technology and rugged microelectronics, we developed a family of remote, unattended ground sensors for perimeter security, battlefield route surveillance, and support of amphibious assaults.

Our experience with deployable sensor systems led to the development of a mini-intrusion detection system for the armed services and other federal agencies. This system provides advanced, cost-effective patrol security for small installations. Sandia's competency and experience base in sensor-based security systems may have application to a variety of unique government requirements.

Our capabilities in providing robotics for the physical security of DOE sites led to the development and demonstration of teleoperated battlefield vehicles. We are also providing consultation as these concepts are developed by the Marine Corps and private industry.

We work closely with David Taylor Laboratories on system studies for electrothermal guns. We develop pulsed power system components for providing energy to

electrothermal guns and we work with Naval Sea Systems Command and their industrial contractors to advance electrothermal gun technology.

## Army

Sandia has unique experience in the design of safe, secure transportation containers for hazardous and radioactive materials. The Army has asked Sandia to apply this expertise to the design, testing, and development of a container for transporting chemical munitions on military installations. Sandia will support private sector fabrication of a fleet of such containers.

We are also developing and qualifying a container for safe air transport of the Army's tactical nuclear weapons, which must be returned to the continental United States for destruction.

We have developed an improved, all-electronic safing and arming system for the Patriot missile. The safing and arming technology in the Patriot system was developed in the DOE nuclear weapons program. The design is being transferred to industry for production, and we are qualifying a supplier for the Army.

Sandia also has unique experience in the design, integration, and testing of terrain-referenced navigation algorithms. Using this experience base, we are applying the Defense Mapping Agency's digital land mass system level-1 digital elevation data to the terrain-referenced navigation and terrain capabilities of the Army's JOH58C helicopter.

Sandia's parachute and control system technologies are being used to develop high-speed, low-level, airdrop resupply systems. We are exploring guidance concepts to destroy high-value battlefield targets and are studying the effects of low-observable materials on survivability in the battlefield of the future.

We are working with the Belvoir Research, Development, and Engineering Center to evaluate the use of backscattered x-rays for imaging land mines. We are integrating an x-ray source, detectors, and imaging technologies into a system and using that system to measure the effectiveness of backscattered x-rays for mine detection in the field.

We are adding models and options to the computer codes developed at Sandia for earlier DOE programs to enhance their capabilities for addressing conventional weapon effects issues, including terminal ballistics problems and other armor-related studies.

## Ballistic Missile Defense Organization

The Ballistic Missile Defense Organization sponsors a broad range of research on technologies relevant to Sandia's prime mission and to its own programmatic goals. We provide support in a number of areas where we

either have special capabilities or unique facilities and where the work complements our DOE mission. We plan to continue working in the areas of discrimination, countermeasures, space power, pulsed power, threat definition, space survivability, space experiments, smart targets, and theater ballistic missile defense.

The countermeasures evaluation activity stems from our experience in nuclear weapon design, our previous activities in reentry vehicle technology, and the application and evaluation of concepts that could make strategic and theater nuclear weapons more robust against a strategic defense. This work will help provide a baseline from which the cost-effectiveness and cost to the adversary of deploying countermeasures may be evaluated. Our activities in threat definition help provide a better understanding of both near- and long-term strategic and theater ballistic missile threats.

The Missile Defense Act of 1991 provided congressional direction to develop a capability to deploy limited ballistic missile defenses by 1996 or when technically feasible. This mandate placed a premium on the timely execution of rocket missions needed in the development of ballistic missile defense technology. Sandia's rocket launching test facilities allow flight testing of instrumented vehicles. The Kauai, Hawaii, facility has been upgraded and is capable of launching strategic target systems boosters. We anticipate continuing to use this upgraded facility to support flight tests for the Ballistic Missile Defense Organization.

Sandia builds unique, instrumented targets for experiments conducted for the Ballistic Missile Defense Organization and the US Army Strategic Defense Command. In order to provide more uniform assessment of proposed strategic defense system elements, a baseline target set has been defined consisting of target vehicles and potential penetration-aiding articles developed by Sandia. The experiments are launched from Vandenburg Air Force Base and the Kauai Test Facility. The Operational Deployment Experiment Simulator is a target deployment platform being built for several experiments that will be flown on strategic target systems missiles.

Sandia's expertise in weapon system analysis will be used to evaluate the utility of smart mines for theater missile defense. We will evaluate and demonstrate this innovative concept for intercepting missiles during the boost phase of flight. The work will require the following: detailed concept definition of all subsystems; rigorous analysis of the concept with regard to sensors, command and control, and launch detection; and test planning and execution for several demonstrations against simulated targets. We will contract with industry for technical and hardware support in the demonstration tests.

We continue to develop our capabilities to model space nuclear power systems for strategic defense applications, and we have produced comparative evaluations of the various systems for the Ballistic Missile Defense Organization, DOE, Air Force, and Army. Our work also

involves developing instrumentation and control technology and independent analyses of safety features.

Sandia's capabilities in radiation hardening are a foundation for evaluating methods and penalties to enhance the survivability of objects in space by hardening the electronics and structure, and for evaluating methods of maneuverability, shootback, and other features.

Capabilities developed primarily for DOE's Inertial Confinement Fusion Program and for aboveground effects simulation and new split-cavity oscillator microwave sources for high-power microwaves are being developed in the interest of more compact jammers, radars, and weapons.

We also provide direct support to the Ballistic Missile Defense Organization's Phase One Engineering Team. In the past, we have chaired the threat specification group for this team. We provide advanced computing capabilities and have developed massively parallel tracking and correlating programs that can handle scenarios thousands of times larger and more complex than was possible previously. The potential for real-time tracking and correlation in realistic strategic defense scenarios will be demonstrated soon. We expect to continue to participate in both threat specification evaluation and command and communications issues.

## Defense Nuclear Agency

The end of the Cold War offered the opportunity for the United States to assist Russia in the safe drawdown of their nuclear arsenal. As part of the United States' Safe Secure Dismantlement Program and under sponsorship of the Defense Nuclear Agency, Sandia is developing an enhanced communications system to aid the Russian accident response team and a transportation and storage container for dismantled weapon pits.

Sandia has supported the Defense Nuclear Agency by providing security hardware to assist Russia in protecting its nuclear weapons from theft or sabotage. Armored blanket technology has been developed and transferred to US industry for manufacture and sale to Russia to protect nuclear weapons from ballistic objects during transportation. In addition, physical security technology has been developed to protect Russian rail cars from terrorist attack. Intrusion detection and delay systems have been produced in modular form for easy transport and installation by our Russian counterparts.

Sandia performs aboveground simulation of nuclear weapon effects for the Defense Nuclear Agency using the Saturn x-ray and Hermes III gamma-ray facilities. Also under sponsorship of the Defense Nuclear Agency, we are developing improved security hardware, operational concepts, and tactics for military security forces.

With sponsorship from the Office of the Secretary of Defense, the Defense Nuclear Agency, and DOE, we are

---

exploring means by which the survivability and security of nonstrategic nuclear forces can be assured in the twenty-first century. The Defense Nuclear Agency also sponsors research and development in sensors for remote monitoring, tamper protection, data authentication, and adversary analysis.

At the request of the Air Force, the Defense Nuclear Agency initiated a pilot study in 1991 for the safety assessment of the Minuteman III weapon system. Sandia's facilities for accident environment simulation (fire test, cable pulldown, sled track, etc.) and experience in nuclear safety assessment are unique capabilities for nuclear safety assessment and for characterizing accidents and system response to accidents in support of this safety assessment study.

The Defense Nuclear Agency is also supporting the development and application of advanced shock physics codes for modeling earth penetrators.

### Advanced Research Projects Agency

In 1993, the Advanced Research Projects Agency began sponsoring the National Center for Advanced Information Components Manufacturing at Sandia to integrate federal and commercial research and development of advanced information components. This integration will enable the United States to greatly compress the time needed to translate research and development into commercial and defense products. The center will complement other DoD microelectronics, optoelectronics, and small-area, liquid-crystal-based display programs. Los Alamos and Lawrence Livermore national laboratories will also support the center, as will representatives from industries and universities.

By providing space and equipment to support development of agile manufacturing processes for large, flat-panel optical displays and microelectronics, the center will allow industry and government researchers to exploit Sandia's wide variety of disciplines and competencies. These competencies include microelectronics and photonics, advanced electronics systems packaging, materials science and processes, printed-circuit fabrication, and smart structures and dynamic systems.

Research will concentrate on agile manufacturing technologies associated with advanced silicon integrated circuits, high-speed optoelectronic communications, and electronic systems and subsystems. Research in large flat-panel displays will benefit from the consolidation of supporting technologies at a single site. Manufacturing research will focus on agile manufacturing processes for flat-panel products for both defense and industry.

Information components manufacturing programs will benefit from several DOE manufacturing development facilities at Sandia, such as the Advanced Manufacturing Processes Laboratory, the Microelectronics Development Laboratory, the Compound Semiconductor

Research Laboratory, the Center for Advanced Manufacturing Technology, the Microelectronics Quality/Reliability Center, the Smart Structures and Materials Laboratory, and the recently announced Center for Microelectronics Technologies.

Beyond technology-specific assistance in the production of essential components, the National Center for Advanced Information Components Manufacturing is expected to address a US weakness in the development of advanced manufacturing technologies. The national center will pioneer and refine approaches to assist the transformation of US manufacturing to knowledge-based distribution and control systems for the factories of the future. It will develop new methods of vibration control to improve the accuracy of high-precision machine tools. By integrating lessons learned from its three associated pilot manufacturing centers, the national center will develop rules and systems for distributed knowledge-based production methodologies featuring open architectures and universal connectivity.

The Advanced Research Projects Agency is funding improvement of Sandia's shock physics codes and applying the codes to improve armors developed by FMC, Simula, and Alliant Techsystems.

Other work for the Advanced Research Projects Agency includes modeling of processes to synthesize advanced materials, evaluation of kinetic energy penetrators, and exploration of the technical issues related to hypersonic weapon systems. Sandia's rocket sled provides the capability to evaluate the key technical issues associated with deployment and lethality at hypersonic speeds.

### Other Department of Defense

The joint DoD/DOE Munitions Technology Development Program enabled by the 1985 DoD/DOE memorandum of understanding is a research effort to develop innovative warhead, explosive, and fuze technologies and to improve nonnuclear munitions technology across all service mission areas. Projects in this program include energetic materials, guidance and control, smart mines, countermines, and systems studies.

Each topical area in this program is overseen by a technology coordination group that acts as liaison between DoD and DOE and establishes a channel for technology exchange. Composed of technical experts from each agency, these groups work to ensure maximum benefit from the program. Technology coordination groups establish measurable deliverables and realistic schedules, coordinate multiservice requirements, establish classification guidance, monitor activity, and provide semiannual reports on the project status and potential new projects. They also conduct technical reviews and provide written assessments to the technical advisory committee. The technical advisory committee adminis-

ters the program, provides policy guidance, reviews technical assessments from the technology coordination groups, evaluates new proposals, and establishes the program plan.

Because much of the technology base developed in nuclear weapons work is directly applicable to DoD needs in conventional munitions, this program has brought about major improvements in conventional munitions. The program is consistent with long-range planning at DoD and is an effective mechanism for leveraging capitalized research and development resources. At the same time, the costs associated with maintaining many of the core competencies required for the nuclear weapons program are shared by DoD, and the resources are further exercised, challenged, and strengthened.

Sandia's microelectronics development laboratory supports several DoD agencies with technology development, custom device design, and limited production items through DOE or commercial vendors. Similarly, Sandia provides unique components (e.g., high-voltage switch tubes) and the consultation of various technology experts (e.g., pyrotechnic device experts) as requested by DoD agencies.

As an outgrowth of our research on novel warhead technologies, we are conducting research and development on methods for quieting future US submarines. We are also using our extensive computer simulation facilities and expertise to demonstrate more lethal warheads for future torpedoes.

For the Defense Information Systems Agency, we have developed a broad range of technologies for survivable command and control centers. These technologies, which include a broadband data bus with computer-aided remote control and monitoring, are being used for classified operational systems and proof-of-concept applications.

Extensive studies continue in precision, quick response weapons for regional conflicts. The Sandia approach would provide a highly integrated target acquisition, data fusion, retargeting, and hypersonic warhead delivery system to address time-critical targets.

## Nuclear Regulatory Commission

Since 1973, Sandia has conducted a broadly based research program for the Nuclear Regulatory Commission in probabilistic risk assessment, severe accidents in nuclear reactors, reactor safety research experiments, engineering technology, low-level waste management, and safeguards and security. We also provide technical assistance in the safety assessment and resolution of reactor safety issues.

We have performed many of the risk assessments

sponsored by the commission, developed state-of-the-art methods, participated in major technology transfer efforts, and addressed important regulatory issues amenable to solution by risk assessment. We have developed methods to analyze power plant systems, operations, human performance, accident processes, transport of radioactive materials, and health and economic impacts. We have placed major emphasis on the treatment of uncertainties in analyzing potential plant accidents.

Our severe accident research program funded by the Nuclear Regulatory Commission involves participation with the international reactor safety research community. Several unique experimental facilities have been developed at Sandia for investigating the diverse physical phenomena that may be important in postulated severe accidents. Out-of-pile experiments to investigate loads imposed on reactor containment buildings by high-pressure melt injection accidents are done in the surety test facility and in a one-sixth-scale model of a nuclear power plant containment. Theoretical work centers on the development and validation of mechanistic codes (such as MELCOR, CONTAIN, and VICTORIA), which integrate severe accident knowledge. Results of the severe accident research are used for developing databases and models for improving hardware and procedures to decrease plant risk, resolve safety issues, and provide the basis for accident management and emergency response.

Sandia has conducted an extensive analytical and experimental containment integrity program, including major tests on a one-eighth-scale-model steel building and a one-sixth-scale model reinforced concrete building. Testing has evaluated the hazards of turbine and external missile impacts. As needed, evaluations of seismic and fire risks are conducted in conjunction with testing. Test facilities have been developed for quantitative measurements of fire behavior and the effects of smoke and combustion products. We have extensively tested nuclear power plant electrical equipment and components during simulated accident conditions. Such tests support equipment qualification and plant-life extension activities.

Sandia is the lead laboratory in the development and application of performance assessment methodologies for evaluating the suitability of nondefense, low-level waste disposal facilities. We are also evaluating methods for classifying waste streams as below regulatory concerns for use in setting minimum standards for radioactive and mixed wastes.

Sandia continues to support the Nuclear Regulatory Commission in transferring technology developed in DOE-sponsored safeguards programs to commission staff and inspectors, and to nuclear utilities. Other technologies transferred to industry or other entities include advanced computer codes and techniques for materials and component design and evaluation.

## Department of Transportation

Sandia performs research for and provides consultation to the Department of Transportation on a wide range of issues including safety, security, and efficiency of the national transportation system. These activities cover all modes of transportation (highway, rail, air, and public transportation) and deal with the movement of both people and goods.

The hazardous materials program recommends packaging performance requirements for hazardous materials transportation and reviews specifications for radioactive materials packaging. We are also developing a microcomputer-based hazardous materials highway-routing guidelines document incorporating a user-friendly model and a user's manual to assist in application of the guidelines.

Experimental work on the thermal characteristics of shipping casks supports Department of Transportation efforts to ensure the integrity of hazardous material containers in fires. We are determining whether a generic boundary condition description can be used for both thermally massive and nonmassive shipping casks. The work also assesses effects of the thermal mass of a shipping cask on the heat transfer characteristics of a sooty engulfing fire. Sandia's radiant heat facility is being used to understand the radiative and convective behavior of heat transfer in such a fire. We recently initiated a program with the Federal Aviation Administration Technical Center to apply this technology to aircraft safety.

We are assisting the Federal Aviation Administration by using our expertise in nondestructive testing to address the problem of aging aircraft. Insufficient knowledge exists about the effects of age on the performance and safety of aircraft to accurately forecast when components should be repaired or replaced. Sandia will develop procedures for commercial utilization of advanced inspection equipment already in use at DoD facilities. New instrumentation will also be developed as required. The program is designed for rapid technology transfer, and Sandia is collaborating closely with industry and academia.

Sandia is also utilizing its transportation technologies and systems engineering skills developed for DOE during the last twenty years to assist the Federal Highway, Federal Transit, and Federal Rail administrations in responding to the Intermodal Surface Transportation Efficiency Act congressional mandates. For example, the Federal Highway and Federal Transit administrations have sponsored a forty-one-state, pooled-funds study at Sandia to develop a transportation planning process and support tools to enable the states to respond to the Intermodal Surface Transportation Efficiency Act. This is the largest state-pooled-funds study ever, and early reviews by the states note that it holds the potential

revolutionize the state/national transportation planning process. Sandia is also helping to revamp future national transportation programs by developing the Federal Transit Administration's functional and architectural requirements for advanced public transportation systems that will directly interface with the Federal Highway Administration's Intelligent Vehicle Highway System's architecture development program.

Similarly, under both state and federal sponsorship, Sandia is studying the feasibility of an intermodal freight center being considered for construction along the New Mexico/Mexico border near Santa Teresa, New Mexico. Sandia's expertise in systems studies and experience with sensors, control, and communication systems will be used to define a center that can more efficiently transfer cargo from one mode (e.g., rail) to another (e.g., truck or air). This work is supported by additional work for the Federal Highway Administration in which Sandia is examining the safety and security of interstate commercial vehicle operations.

## National Aeronautics and Space Administration

Sandia provides technical support for a number of NASA-funded projects. Leveraging the experience gained in conjunction with DOE's verification and control technology program, we provide instrumentation to support space-based experiments for which the science partner is often an educational institution performing work with NASA funding.

For example, we support the Columbia University Astrophysics Laboratory in developing an x-ray polarimeter experiment for the Russian spectrum-x-ray gamma satellite. We are providing design support for the mechanics of granular materials instrument, a microgravity experiment in collaboration with the University of Colorado and NASA. Similar design support is being furnished in collaboration with Los Alamos National Laboratory and Pennsylvania State University for the optical monitor experiment for the European Space Agency's x-ray multispectral mission satellite.

Sandia was recently selected for flight definition of a space shuttle experiment designated critical dynamics in microgravity. This is a fundamental science, low-temperature physics experiment involving staff and students from the University of New Mexico, California Institute of Technology, the Jet Propulsion Laboratory, and Sandia.

We developed a unique capability in radiation-hardened microstructures for the nuclear weapons program. Such devices are useful for space applications. We design, fabricate, and produce radiation-hardened engineering prototypes of selected microprocessors for NASA.

Another of Sandia's unique strengths in microelec-

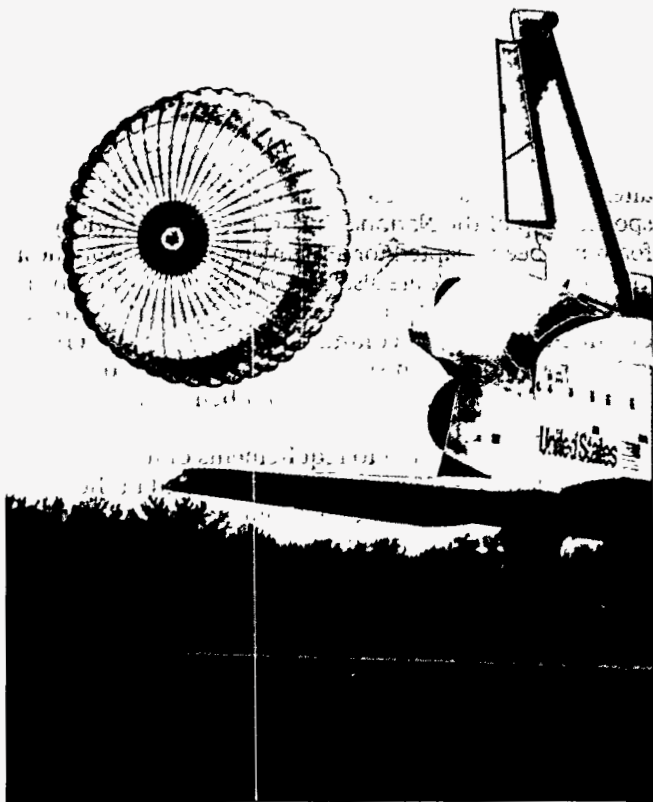

Sandia's parachute program has made several significant contributions to NASA's space programs. The space shuttle now uses a Sandia-modified drag chute to slow the vehicle during landings.

tronics is compound semiconductors. We are working with NASA's Jet Propulsion Laboratory to employ this technology to develop longer wavelength photovoltaic arrays for electrical power supplies in space. We seek to grow stable, strained-layer superlattices that exhibit significant optical absorption at wavelengths to fifteen microns and beyond. The work includes buffer design and growth, x-ray verification of structure and composition, analysis of defects, and photoluminescence characterization of the resulting superlattice. This work is a critical phase of materials development for demonstration of reproducible, spatially uniform material with the desired infrared characteristics. The follow-on task will be fabrication and optimization of detector and array structures.

Sandia is the world leader in the theory and design of

high-performance parachute systems. We advise NASA on the conceptualization, definition, and design of high-speed parachutes, including those used to decelerate the space shuttle's solid-fuel rocket boosters upon separation and the shuttle itself during landing. We are working with the Johnson Space Center to develop a capability for soft landing and recovery of spacecraft and reusable launch vehicle hardware. We are also applying our parachute and aerodynamics expertise to develop and test an airbag system to provide soft landing of payloads on Mars.

Sandia's microsensors expertise is being applied in a joint Sandia, NASA Ames, and Jet Propulsion Laboratory effort to develop a sensor-designated Mars oxidant (MOx) to measure the reactivity of the Martian soil and atmosphere as part of the Russian Mars mission. In addition, similar expertise is being used to merge hydrogen-sensing alloys with microchip technology to produce hydrogen sensors that NASA will use to improve the safety of its rocket operations.

Sandia supports and provides certain space-qualified hardware to NASA and the European Space Agency. We are providing a number of radiation-hardened, large-scale, integrated circuit devices for the Venus radar mapping mission. We also support the development of recovery systems for instrumentation sent into orbit.

## Department of State

Under sponsorship of the Department of State, Sandia provides direct technical support to the International Atomic Energy Agency in its role of verifying compliance with the provisions of the Nonproliferation Treaty. The agency employs both material accounting procedures and containment and surveillance techniques to provide the safeguards measures required by the treaty. We are developing or analyzing secure containers, spent fuel attribute testers, and item monitoring equipment. Newly developed containment and surveillance equipment is being demonstrated. We will help implement the new equipment by providing training, maintenance, and documentation. We will continue to provide containment and surveillance consultants as requested. We will also assist the International Atomic Energy Agency with training and inspection of physical security systems.

## Environmental Protection Agency

Under an interagency agreement and other developing cooperative efforts between DOE, the Environmental Protection Agency, and various other government agencies, Sandia provides technical assistance and proposes technical courses of action for site characterization, sensor technology, remediation technologies,

advanced analysis approaches, and risk-based decision approaches.

DOE and the Environmental Protection Agency have a long history of coordinating science and technology projects, including the Energy and Environment Program of the early 1970s, the National Acid Precipitation Assessment Program of the 1980s, and the National Laboratory Consortium formed by the National Acid Precipitation Act of 1980. The Environmental Protection Agency and DOE have approved thirty-five memoranda of understanding over the past two years for joint research and development under DOE's environmental restoration program. There have also been several memoranda of understanding on general cooperation and technology transfer. These efforts are expected to accelerate because DOE has recently committed to work closely with the National Resources Cluster of the president's cabinet to address national environmental issues.

For example, DOE and the Environmental Protection Agency have recently initiated a joint laboratory directors' forum to foster more cooperative environmental research efforts between the two agencies. The forum consists of the directors of each agency's research and development laboratories and is actively collaborating in research and in identifying topics for joint research in the areas of pollution prevention, waste minimization, environmentally sensitive engineering and manufacturing, hazardous and mixed waste treatment, ecological research, monitoring and assessment, and environmental risk assessment. Sandia, as one of DOE's major research laboratories, will provide technical assistance and leadership in these areas.

Sandia has established a number of initiatives with the Environmental Protection Agency to assist regulators and encourage the use of innovative environmental technologies. In one initiative, Sandia, industry, DOE, and the Environmental Protection Agency are collaborating to demonstrate innovative cleanup technologies at a DOE site. This initiative provides an opportunity to develop a model for accelerated environmental cleanup operations throughout the nation. Another initiative is the consortium for site characterization technology. In this consortium, the Environmental Protection Agency's Environmental Monitoring Systems Laboratory in Las Vegas, Sandia, and several other federal laboratories are facilitating the development and commercialization of innovative monitoring and site characterization technologies through accelerated demonstration and validation.

As part of a regional effort, Sandia is supporting efforts by DOE, the Environmental Protection Agency, DoD, the Department of Interior, and the Western Governors' Association to accelerate environmental technology development and cleanup activities while enhancing economic development in the West. Sandia is also helping the Environmental Protection Agency in decision support systems and air pollution measurements.

## Other Federal Agencies

Sandia continues to support the National Security Agency in adversary analysis. This involves evaluation of communications security equipment, components, and design proposals to determine and identify vulnerabilities having a potential for exploitation by an adversary.

Sandia's experience in safeguards and security for nuclear materials and facilities has been applied to other federal security needs. We are developing nonlethal alternatives for law enforcement officials under the sponsorship of the National Institute of Justice. Sticky foam has been adapted for a foam gun that can subdue a violent prisoner. We are also developing an aqueous foam system that can quell prison riots. A third project utilizes our nuclear weapons command and control expertise and our experience in surety technologies to develop a smart gun to prevent officers from being shot with their own weapons.

Sandia is responding to requirements of federal, state, and local law enforcement agencies involved in the war against illegal drug trafficking. Sandia was explicitly named a national technical resource in the Drug Abuse Act of 1989. Our response has been sharpened by extensive interactions with interested agencies at all levels, from individual agents patrolling the border to headquarters units involved in enforcement and research and development. We completed a study for the Immigration and Nationalization Service on the protection of the US southwestern border and presented recommendations for reducing drug traffic.

This effort has three focuses: attempting to match available technologies with requirements to provide immediate solutions; defining and proposing long-term development efforts in areas where Sandia has expertise; and offering systems analysis support to better define and prioritize drug interdiction approaches. Immediate support is available in such areas as ground sensors, communications, and radio-frequency beacons. Developmental areas include laser-induced fluorescence, compressed video communications, and passive beacons.

These efforts have produced contractual arrangements with several agencies, and we expect these programs to expand as agency research and development budgets grow and the drug war becomes better organized.

## All Other Reimbursables

We are developing a new computer code for predicting the response of fluid-bearing rock to injection of slurries for disposal of drilling waste. The model also has application to analysis of many production problems associated



---

with reservoir response for the oil and gas industry.

Where appropriate, Sandia also enters into projects involving state governments, private industry, universities, foreign governments, or other nonfederal entities. Criteria for these arrangements are the same as for other work-for-others endeavors. Current projects entail a variety of activities and Sandia resources, including development of numerical models for rock blasting, computer modeling to predict chemical behavior in

methane-air jet flames, microelectronics development, and studies to improve nuclear reactor safety. We have projects with the United Kingdom, including electrical system and command and control support for their warhead development project, development of accident-resistant containers and associated handling gear for recovery of damaged warheads in an accident, and engineering support for US-supplied components and testers for their Trident-like reentry system.

*Infrastructure &  
Support*

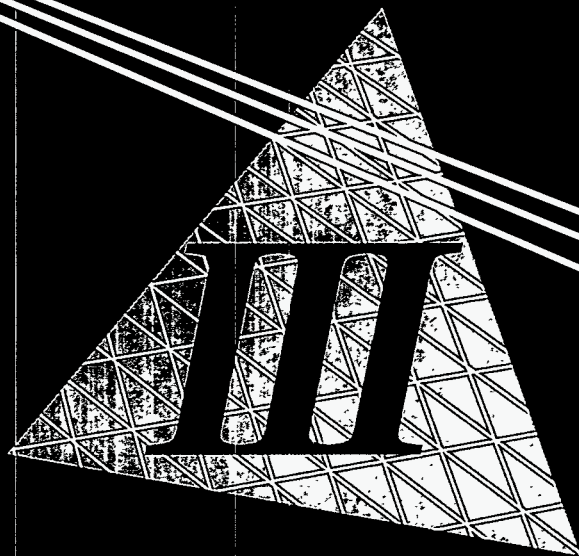

## 8 • *Human Resources Management*

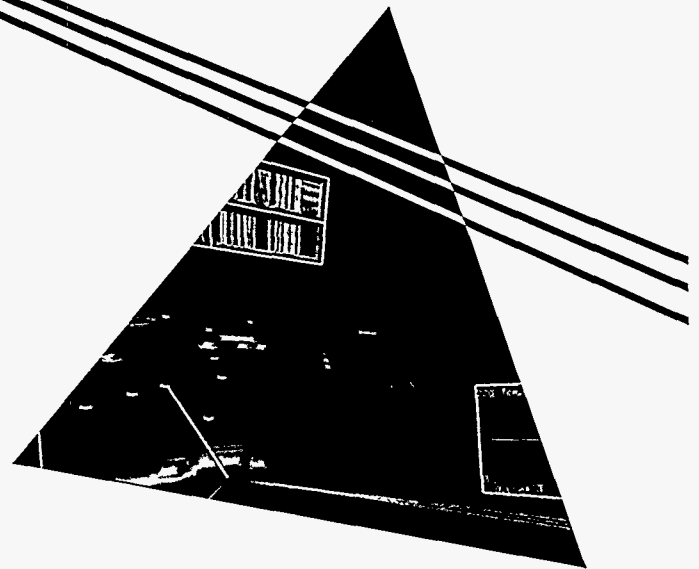

Management of human resources at Sandia is consistent with DOE's strategic goals for attracting a well-trained and highly motivated work force and achieving a diversity that reflects American society.

Sandia's human resources policies are geared toward providing the best talent to support DOE missions. To recruit and retain outstanding technical staff, we offer challenging scientific and engineering assignments in multiple mission areas. Prudent management of Sandia's human resources will help us achieve our long-term programmatic goals within the context of changing work requirements and evolving demographic and societal trends.

### Laboratory Personnel

Sandia's people are key to its ability to succeed in its missions. In the current environment of evolving work priorities, continuous change, and fluctuating budgets, Sandia's intent is the maintenance and full utilization of a work force of talented, creative people dedicated to "exceptional service in the national interest."

### Human Resources Planning

The Sandia National Laboratories Strategic Human Resource Plan was first published in October 1992 and was revised and reissued in October 1993. It covers a five-year planning horizon and outlines a set of critical issues obtained from the analysis of laboratory requirements and employee needs. Five areas of strategic focus were established to address the critical issues: staffing, performance management, leadership and management development, work force diversity, and productivity improvement and cost management. The implementing initiatives for these areas of strategic focus follow:

- Integrate the hiring, internal movement, and labor contracting processes to place the right person in the right job at the right time based on near- and long-term forecasts of the required skills mix and consideration of cost, morale, and other factors.
- Establish a "line of sight" for expected performance outcomes from the strategic through the operational levels and for improving the performance (both results and behavior) of individual employees and work groups throughout Sandia.

- Continually improve the ability of Sandians to lead others and manage organizations, programs, and projects in an environment of constant change and evolving priorities.
- Create and retain a world-class diverse work force, improving processes and opportunities to develop employees, and creating a work environment where all employees can contribute fully to the success of Sandia.
- Improve the productivity of Sandia's people by finding ways to support and leverage their capabilities and by focusing on and managing laboratory-wide human resource costs (including increment, indirect, and direct components).

Agility is the cornerstone of Sandia's staffing initiative. In an environment of rapidly shifting customers and funding, it is imperative that we effectively utilize our employees—quickly moving people internally to accommodate shifts in emphasis from one area to another and offering training options for employees who wish to move into strategic growth areas.

The Strategic Staffing Forum was chartered in June 1993 so that staffing needs could be discussed in real time throughout the year. The forum also provides the central focus for ensuring that staffing each year is in keeping with projected revenues and that all staffing decisions support the overall corporate strategic directions. The tie with budget planning allows proactive positioning for areas that may see funding cuts, as well as areas that are targeted to grow.

The Employee Development Center was established in 1993 to provide a centralized, Sandia-wide resource for marketing the skills of employees who are available for internal reassignment. By enabling managers to review the pool of internal candidates first, Sandia makes every attempt to leverage the value of its current work force while offering solutions to managers' staffing needs.

The Sandia resource profile, scheduled for implementation in 1994, will provide the first-ever, all-inclusive inventory of Sandians' skills. All employees will be asked to submit résumés for the corporate database. These résumés will be evaluated by the software system (Resumix) to extract actual skills, as opposed to education history or organizational assignments. This inventory will enable Sandia to assess capabilities that may need to be targeted for future hiring, based upon projected funding and areas of strategic emphasis.

Performance management at Sandia is based on an annual cycle of establishing a plan to reflect performance expectations for the upcoming year, providing development opportunities and ongoing feedback, and formally evaluating performance and achievement relative to the set of planned expectations. Performance measured against the plan is a factor in

making compensation and other reward decisions.

Sandia's strategy is to implement performance management, consistent with Sandia's mission and values, for all positions at all job levels. Implementation has been phased to provide a customer-focused design and incorporate lessons learned. Design objectives were to

- ensure that employees understand the relationship between their contributions and the business plan,
- encourage open communication between employees and their supervisors regarding performance,
- ensure that employees clearly understand their specific job responsibilities and performance expectations, and
- link pay to performance.

Executive levels of management are in their second year under the performance management process, and employees in represented job categories have completed training and established performance plans for their first full year under the new process. Design teams of managers and staff have made their recommendations regarding the process for the rest of Sandia's population, and management has participated in a one-day workshop to prepare for performance management.

Implementing performance management at all job levels will establish expected performance outcomes from the strategic through the operational levels, linking compensation to achievement of organizational and individual results. It will also establish employee and managerial responsibility for identifying work requirements and tracking intermediate results, and will set up a context for soliciting feedback from customers and stakeholders. Leaders and managers (not Human Resources) must emphasize performance management as the communications and feedback process that will keep everyone focused on Sandia's goals.

Sandia's leadership and management development effort is guided by a set of well-defined company values, a strategic plan, and recognition that the company is moving toward being an agile enterprise with a strong focus on development of our employees.

The agile organization is characterized by rapid idea-to-design conversion, constantly evolving products and customization, totally integrated organizations and concurrent processes, opportune partnerships, and product value based on customer-perceived value. At the center of an agile enterprise are networks of people: employees, partners, customers, suppliers, and stakeholders. Skills and decision-making capability are highly leveraged, job structures are flexible, relationships of mutual trust and responsibility are valued, cooperation is the first choice approach, information is shared, and

---

goals are jointly set and pursued. Agile organizations require continued learning and leaders who can coordinate networks of people to create processes and products within windows of opportunity.

Sandia's leadership and management development program will transform our leaders' and managers' styles and practices to meet these new requirements for agility and high performance. The program emphasizes understanding and developing needed leadership skills while continuing to build upon a solid base of management know-how.

Recognizing leadership as identifiable and learnable competencies is the first step in the transformation process. Toward this goal, a guidebook for Sandia's leaders and managers delineates desired leadership competencies and behaviors associated with those competencies. These competencies are integrated within a framework that helps Sandia's leader-managers to focus the talents and efforts of our people on the right work, achieve the technological leadership vision outlined in Sandia's Strategic Plan, and execute Sandia's stated business strategies.

The leadership and management development guidebook contains references and recommendations for assessing skill gaps vis-à-vis the competencies and producing development plans for individuals that include challenging job assignments, ways of learning from others, and recommended training courses. The guidebook implements a near-term objective—the identification of competencies and resources to assist personal development. The far-term objective is to attain a more holistic approach to leadership and management development not focusing exclusively on promotion, but on a broad perspective of developing leader-managers to guide Sandia.

The productivity improvement and cost management initiative (based on a cost/benefit analysis) focuses on the highest leverage opportunities in the near-term: health care coverage, strategic staffing, and training and development.

Two principal elements of the health care strategy involve integrating wellness, employee assistance, and other on-site medical services with health care benefits. The purpose is to positively influence participants' lifestyles while managing health care provisions and cost, based on national benchmarks. The health care plan will maintain access to quality medical care for Sandia plan participants while managing escalating costs through such techniques as negotiated facility price discounts.

The cost management objective of strategic staffing involves planning the work force composition in the near- and long-term so that the right skills mix is in place when required and the cost of the work force is appropriate in start rates, ongoing compensation, and utilization. The strategy includes a hiring program that considers the following: skills needs and long-term monetary investment in degree level or job classification; a decision tool

for determining when it is more cost-effective to out-source work or use contract labor; and mechanisms for the timely redeployment of people.

The training and development strategy invests in on-roll employees to maximize productivity. Elements include the following: focusing training and development activities on specific business objectives of Sandia's sectors and divisions; monitoring results of training to demonstrate return on investment; and centralizing training and development to avoid costly duplication of efforts. An executive-level oversight committee has been established and a corporate education policy and funding process are being developed.

## Human Resources Programs

Sandia's management is committed to preserving the vitality and quality of the technical, management, and support staff. In general, Sandia applies the personnel "best practices" used by comparable research and development organizations while maintaining compliance with the terms of the management and operating contract. These practices include the following:

- conducting nationwide recruiting efforts at leading universities for the best qualified technical candidates from all disciplines of engineering and the physical sciences;
- continuing education, training, and related skills development for all segments of the work force, based on needs assessments of current job performance requirements and career paths;
- fostering a work environment that emphasizes customer focus and quality improvement, participation in local decision making, open communications, and self-management;
- compensating people based on performance outcomes and recognizing specific accomplishments with monetary and non-monetary award programs; and
- providing cost-effective employee benefits and services such as work and family services, health maintenance programs, and employee assistance programs.

Sandia has recruiting programs to attract the best talent available for permanent and temporary employment. Campus recruiting focuses on persons having PhD, MS, and BS degrees, and on technical institute graduates. Ninety to one hundred recruiters visit twenty-four campuses to interview PhD candidates and ninety

recruiters visit thirty-six campuses to recruit BS and MS candidates. Twenty-four recruiters visit twelve technical institute campuses. All recruiters have regular job assignments, and recruit on a part-time basis. Each recruiter is trained before going on campus to ensure that Sandia will be properly represented and that a diverse pool of candidates will be interviewed.

Special temporary and summer recruiting programs attract qualified candidates for job assignments at Sandia. These programs are intended to have a positive effect on future diversity hiring goals by encouraging participants to further their education, which may qualify them for permanent positions.

Training, development, and education are viewed as a strategic investment in Sandia's future. The purposes are to

- assist Sandians in preparing themselves for future technological advances,
- maintain Sandia's technical and business capability, and
- meet mandated and compliance-related training, development, and education requirements.

Sandia's Corporate Training and Education Council, a fourteen-member board consisting of directorate representatives from organizations across Sandia, oversees the corporate training, development, and education programs. This council helps ensure that Sandia's corporate training and development function is directly aligned with corporate strategies and business plans and supports the corporate mission, values, and objectives. Alignment and support are provided by offering individuals and groups a wide variety of high-quality, job-related performance improvement and development opportunities. The scope of these opportunities includes gaining and applying knowledge, skills, and abilities in the advancement of technology, quality human processes, personal health and safety, and protection of the environment.

Training needs of the staff are determined through ongoing assessments. Curricula are developed to target specific job performance improvements. Emphasis is currently on the following curricula: agile manufacturing; software engineering; project management; quality; environment, safety, and health; and leadership and management development. Corporate training and development for internal customers are discussed below.

The In-Hours Technical Education Program supports Sandia's mission and goals by ensuring the continued technical expertise of the staff, satisfying technical demands of current programs, and expanding technical capabilities for future programs.

The Tuition Assistance Program pays tuition for employees enrolled in university continuing education courses.

The Doctoral Study Program pays expenses and stipends for full-time study toward the PhD degree.

The One-Year-on-Campus Program meets Sandia's affirmative action objectives by paying expenses and stipends for new hires with bachelor's degrees to study full time for a master's degree.

The Distance Learning Program provides seminars and full semester courses via video link from universities or other locations to Sandia sites. This program offers an extensive curriculum required for compliance with DOE orders related to environment, safety, and health.

Sandia is a company in transition. In recent years, employees have experienced major shifts in work, uncertain funding, company-wide restructuring, and a transition from one management and operating contractor to another.

However, a Sandia-wide survey in October 1993 showed that employees feel better about their work environment than they did when a similar survey was conducted in 1991. Although Sandians' perception of job security diminished, they had better perceptions of their immediate managers, opportunities for involvement in the company, and personnel policies and practices. A work environment is evolving that emphasizes more teamwork and open communications in addition to technical competencies.

Sandia recruits at leading colleges and universities to obtain the best possible employees. We recognize that compensation for outstanding staff is responsive to market forces. Therefore, we pay close attention to compensation surveys of leading research and development firms with engineering and scientific personnel.

In conjunction with the performance management initiative of the Strategic Human Resources Plan, we manage our compensation program to reward accomplishment of individual and team goals to support Sandia's strategic and operational plans. One of the primary objectives of the compensation system is to reward performance appropriately over time. As a result, new hires will be attracted to a Sandia career in which they have the opportunity to do challenging, satisfying, and exceptional work in the national interest.

Over time, Sandia has developed and maintained a balanced, competitive, and cost-effective employee benefits package to attract and retain high-quality staff and to provide financial security in retirement for career employees. Sandia benchmarks its benefits package against private sector research and development companies and other DOE management and operating contractors to remain competitive.

Sandia optimizes the limited resources available for

employee benefits through careful stewardship of DOE funds and effective cost management and fiscal control of plans and programs. Most health and welfare plans are self-funded and administered by vendors selected through a competitive procurement process. Additionally, strong emphasis is placed on compliance with laws, regulations, and DOE orders. The benefits package is highly valued by Sandians and is considered an integral part of the total compensation package that supports a good quality of life and a productive, diverse work force.

## Equal Employment Opportunity/ Affirmative Action and Diversity

The diversity and equal employment opportunity/affirmative action vision for Sandia is to become a national leader in valuing the diversity of all employees and integrating diversity into all aspects of conducting business. At Sandia, diversity means creating a work environment in which differences are valued and used to improve laboratory performance. Sandia continually strives for a work environment where mutual respect and opportunity are fostered for all employees.

Respect for the individual, one of five corporate values articulated in Sandia's Strategic Plan, continues to be the foundation for human resources policies, including affirmative action and equal employment opportunity. Although compliance with applicable equal employment opportunity/affirmative action laws and regulations is legally mandated, Sandia's approach is based on a moral commitment to all individuals regardless of race, religion, gender, age, national origin, veteran status, sexual orientation, or disability. Terms and conditions of employment affected by Sandia's equal employment opportunity/affirmative action commitments include the following: recruiting, hiring, and training; promotion, compensation, and benefits; transfers, layoffs, and returns from layoffs; Sandia-sponsored training, education, and tuition assistance; and social and recreational programs.

Sandia's personnel process assures a thorough and systematic consideration of qualifications, job requirements, and possible accommodations. Physical and mental job requirements are reviewed to ensure that such requirements are job-related and consistent with business necessity and safety.

## Equal Employment Opportunity and Affirmative Action

During the past five years, the percentage of women and minorities in all job classifications increased by 22.24



Jim Costa was one of hundreds of Sandians who viewed the exhibits at the Sandia Diversity Outreach Team meeting in August 1994.

percent and 4.56 percent, respectively. Based on US Census data for 1990 and recent data on internal opportunities (hires, transfers, and promotions), Sandia has not fully utilized women and minorities in all job classifications. However, corporate and division goals have been established where underutilization exists. These goals are part of the corporate affirmative action program and are a part of each vice president's affirmative action plan. Vice presidents are accountable for goals identified in their performance plans.

In FY 1993, goals for women were met in eight of eighteen underutilized job groups. Goals for minorities were met in seven of eleven underutilized job groups. At the beginning of FY 1994, women were underutilized in seventeen of forty-three job groups and minorities were underutilized in fourteen of forty-three job groups.

A detailed profile of Sandia's diverse work force and a description of our progress toward meeting FY 1993 affirmative action objectives are in Sandia's 1994 Affirmative Action Program.

Another method for assessing progress toward affirmative action goals is Sandia's internal compliance review. This process involves an in-depth review and analysis of each component of the affirmative action plan and other relevant data, such as compensation and formal charges. An internal compliance review is under way.

Plans for achieving a diverse work force and full compliance with equal employment opportunity and affirmative action regulations have included some recent changes in the management structure to facilitate achievement of the established objectives.

The Diversity Leadership Center was established in 1992 to give higher visibility to diversity issues and to implement a comprehensive diversity plan. This new organization is composed of the Equal Employment Opportunity/Affirmative Action Department and the Diversity Planning Department. The Diversity Leadership Center staff was increased during FY 1993 to be more responsive to the needs of all customers and accomplish the goals of the organization.

This center has also identified the need for development and implementation of an information system to meet the needs of all users of equal employment opportunity/affirmative action data. Reliable and timely reporting and access to data are critical in achieving full compliance. The current affirmative action management system is being upgraded and will be used to track and monitor status and trends of formal and informal complaints filed by employees. An affirmative action information system and local area network are being developed.

## Diversity Programs

Diversity leadership at Sandia will sustain an environment in which the full potential of all employees is realized. Diversity leadership is intended to shift our culture from being compliance-oriented to one that is values-, people-, and business-oriented. There are three components of diversity leadership: affirmative action, valuing differences, and managing diversity.

Affirmative action is a tool to help create a work force from a broader pool of highly qualified, talented people. These are compliance efforts that affect our hiring and promotion.

Valuing differences emphasizes that differences exist in such areas as race, gender, age, physical abilities, job classification levels, educational backgrounds, and styles of thinking. The focus is on building a work force with the knowledge, tools, and understanding to capitalize on the strengths that arise from differences.

Managing diversity examines the organizational systems and processes we have in place to support an increasingly diverse work force. We are creating a system that works for everyone—not just nonminority males or protected groups.

All three components of diversity leadership are important to creating the kind of work force and work place where everyone can fully contribute.

The Diversity Leadership Center founded in 1992 and the Corporate Diversity Team founded in 1993 involve Sandians from all walks of life in achieving cultural change at Sandia. The resultant diversity infrastructure is discussed below.

The Sandia Quality Leadership Council is responsible for corporate affirmative action planning.

The Diversity Leadership Council focuses on the managing diversity component, looking at the systems that supports diversity in the workplace, and leading the effort toward full utilization of the work force.

The Corporate Diversity Team is composed of a cross-section of employees and first-line managers, and is headed by a technical director. This team helps Sandians improve the work environment and productivity by respecting, valuing, and utilizing individual differences.

Diversity action teams, spin-offs from the corporate diversity team, gather data and implement solutions to help improve our work environment diversity.

Champions and partners accelerate the process of change related to diversity. This group of Sandians from all walks of life (upper and line management, staff, and represented employees) will have a working understanding of diversity and its relationship to Sandia's effectiveness, and will create a support system for the corporate-wide diversity training to begin in FY 1995.

Diversity leadership is not just about the work force, but includes other dimensions of the business environment. Thus, Sandia focuses on five business areas in diversity leadership: work force; community outreach; education outreach, subcontracting, and technology transfer.

Outreach/Inreach and other action-oriented programs are vital in creating a work force that values individuals' differences and recognizes diversity as a competitive advantage. At Sandia, outreach/inreach committees have



Members of the Sandia Diversity Outreach Team, Sheila Daigle-Béard and Juanita Jones, talk with persons viewing the displays.



---

been established for American Indians, Asians, Blacks, Hispanics, women, and the disabled. Each committee has twelve to twenty-five members from both the technical and administrative staffs. The outreach programs contribute to Sandia's affirmative action efforts by partnering with community contacts to identify women and minorities for possible employment at Sandia and increasing sensitivity and cultural awareness. Examples of committee activities include career fairs, conferences, tours, lectures, and cultural celebrations.

Sandia sponsors five additional affirmative action employment programs. The One-Year-on-Campus Program has resulted in the employment of 101 technical

professional minorities and women at Sandia since 1983. For more than ten years, Sandia has also contracted with Career Services for Persons with Disabilities for employment and training of people with disabilities.

In addition to the employment-related programs noted above, Sandia affords maximum opportunity to minority- and women-owned business enterprises to participate as suppliers and contractors. Sandia has had a very active disadvantaged, women-owned, and small business program for many years and has received awards from organizations such as the Small Business Administration and DOE.

## 9 • Sites and Facilities

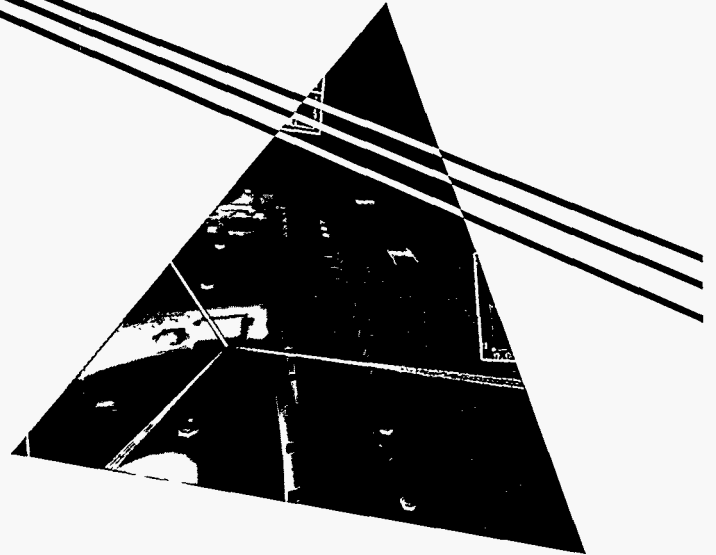

Sandia's executive management offices and larger laboratory location are on Kirtland Air Force Base on the southeastern edge of Albuquerque, New Mexico. Another Sandia laboratory complex in Livermore, California, adjoins Lawrence Livermore National Laboratory. Test ranges are operated near Tonopah, Nevada, and on the Navy Pacific Missile Range on Kauai, Hawaii.

### Laboratory Description

A general description of Sandia National Laboratories' New Mexico and California facilities appears in chapter 3, "Laboratory Management Overview."

### Facilities Plans and Options

#### Site Development

Sandia's Site Development Plan, updated annually, contains a comprehensive description of planned facility changes. The plan contains a short- and long-range outlook for each of the four principal Sandia sites. In the

current dynamic environment, this plan is becoming an evolutionary document in which site locations for future facilities are tentative. Exact locations of future facilities, site infrastructure, and the types of activities they will support are determined through business planning and site evaluations.

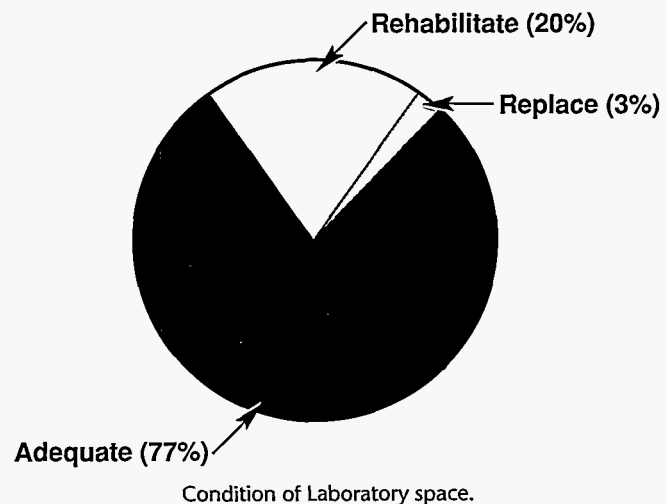

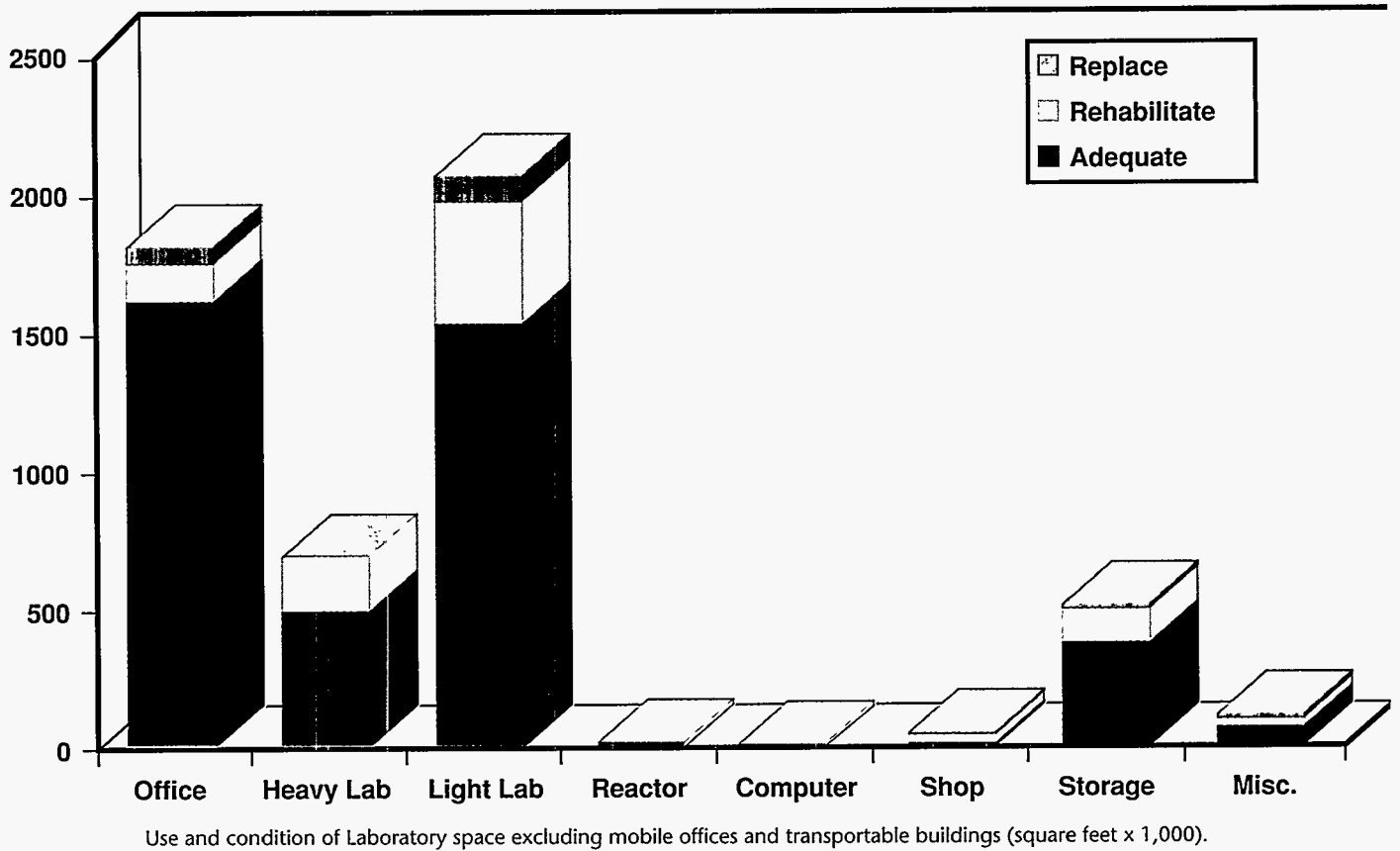
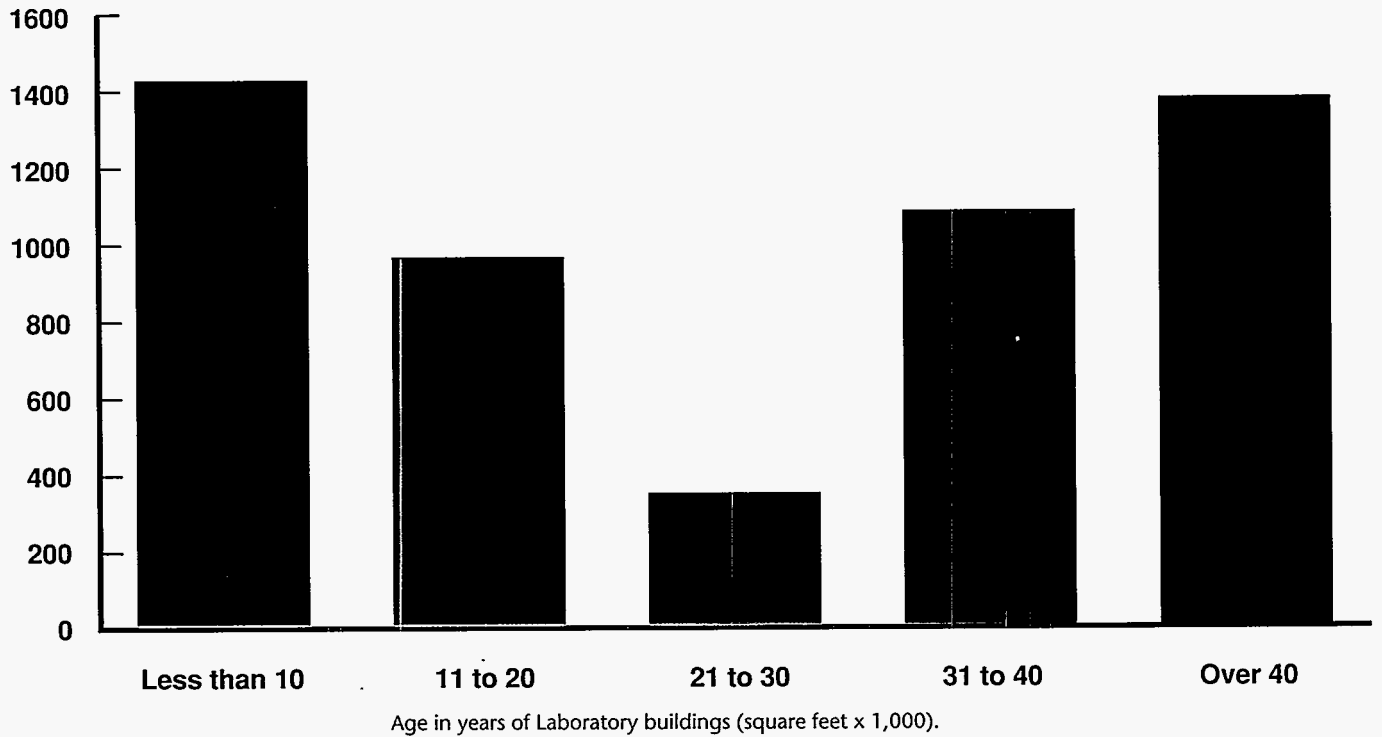

Sandia's site development planning is intended to relieve space shortages and construct permanent buildings to replace temporary ones, while converting the site to support more open access and unclassified activities. As the construction program permits, we will retire mobile offices, trailers, transportable buildings, and other substandard space. In addition, our site development planning will consider the requirements of the National Environmental Policy Act and site environmental restoration activities.

Three essential factors underlie Sandia's site and facilities plan. One factor has existed from Sandia's founding, when the nation urgently needed to build a nuclear arsenal. The Laboratories did not have adequate permanent buildings then, and the problem has never been fully corrected.

A second factor is that profound changes have occurred in engineering practice and the supporting scientific disciplines since Sandia was founded. During the 1950s, much of Sandia's engineering work was straightforward and was checked with extensive field

testing. But for many years now, cost-conscious engineering has been intensely analytical, relying heavily on elaborate, sophisticated instrumentation that requires control of temperature and vibration to achieve repeatability and reliability. With this evolution, staff moved from the field to the laboratory. Laboratory work proliferated, the complexity of measurements and apparatus increased, and professional requirements for staff were raised. The recent moratorium on underground nuclear testing, coupled with Sandia's continuing responsibilities for ensuring stockpile reliability and nuclear weapon surety, will increase requirements for both laboratory simulation and computational capabilities. These changes create new needs, such as that for the Jupiter pulsed power facility proposed for FY 1998.

The third factor is the dramatic changes in the international environment, including the demise of the Soviet Union and Warsaw Pact, the shift from military to economic competitiveness, and the consequent impacts on Sandia's future missions. Greater emphasis on technology transfer, economic competitiveness, and



Sandia National Laboratories, Albuquerque, New Mexico.

teamwork with private sector partners in unclassified research and development will require conversion of the New Mexico and California sites to more open, industrial research park environments. This change will include site improvements to ease access for unclassified activities, new facilities to support changing missions, and accompanying infrastructure investments to support site conversion.

Sandia, like other national laboratories, is working much more closely with US industry, especially nondefense industry. These close associations require extensive on-site interactions with unclassified personnel and are generating much new unclassified work. The fact that Sandia's primary location is on a military installation can make doing business with private-sector partners awkward. If this sector of the Laboratories' business is to grow

significantly and if industry is to have better access to the substantial government investment at the laboratories, we must overcome these impediments while continuing to protect classified and proprietary information and maintaining the security requirements of the host military installation.

This change will involve rearranging the New Mexico site into classified and unclassified business areas and making improvements in public access, traffic circulation, parking, and other infrastructure. It will also require reconfiguring the California site to increase the areas of unclassified access. Although security boundaries have been changed by moving several major facilities from limited to unclassified areas, adequate funding to convert additional facilities to this more accessible configuration is not currently available. In addition, significant invest-



Sandia National Laboratories, Livermore, California.

ment will be required to allow Sandia to convert portions of its sites to public access areas to support both business and community outreach activities.

The changes in our mission and customer mix also provide an overarching requirement to increase the timeliness of our responses to new initiatives. Construction is sometimes necessary to provide laboratories, prototyping lines, and other facilities to support technology transfer and economic competitiveness. Recent changes in the construction line-item approval process developed by a team sponsored by the DOE Albuquerque Operations Office will reduce the time required to request and gain approval for construction funding. This new process should reduce the cycle time for constructing low-risk line item projects from eight to four years, allowing Sandia to better respond to our new missions

and customer base.

Other important factors we must consider in our facilities planning are: the need to conserve energy; new environment, safety, and health regulations; changing physical security requirements; and the requirement to provide special purpose buildings for certain applications.

Older structures, particularly temporary buildings, waste energy and are expensive to maintain. More stringent requirements for protecting the environment and the safety and health of employees and visitors make continued use of some of these facilities impractical. Changes in physical security regulations (allowing the use of concepts such as islands of security) and in the nature of the materials and data being protected (from weapons-related to proprietary information) will allow dramatic reconfiguration of the limited areas. New

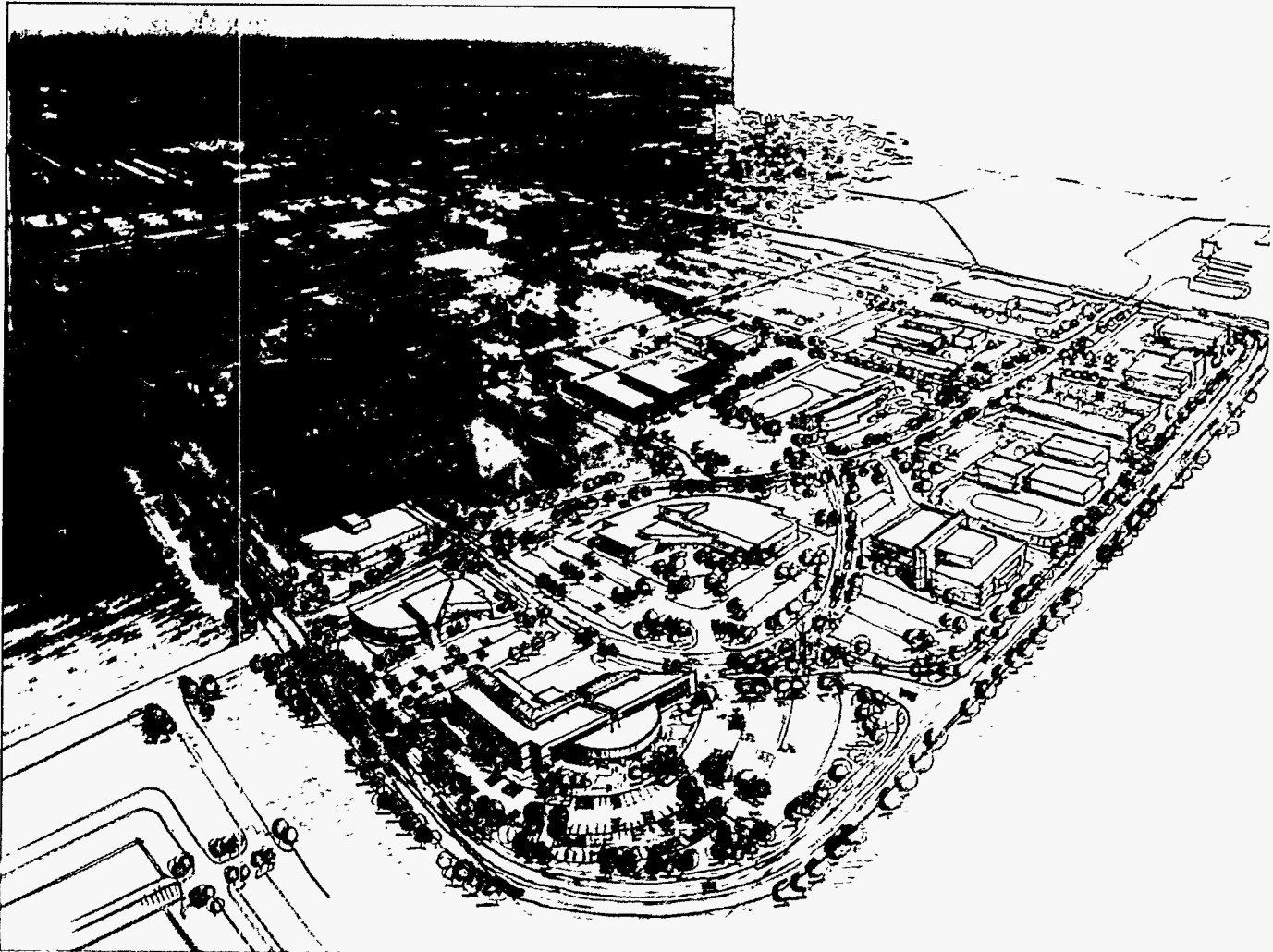

This artist's conception shows the proposed DOE entrance on Eubank Boulevard at the Sandia/New Mexico site. The visitors' center is in the foreground.

technologies and activities will demand that facilities be designed to support unique requirements. New facilities will be required to accommodate microstructure fabrication, pulsed power machines, special instrumentation systems, environmental and energy research, rapid prototyping and advanced manufacturing techniques, and computer centers.

Sandia must also reduce dependency on buildings borrowed from the military and will evaluate how to reduce its use of off-site commercial leased space. Sandia's New Mexico location relies heavily on borrowed or leased Air Force buildings and sites for testing and warehousing; if the Air Force needs these buildings and sites, they must be returned. Although planned construction will help relieve problems of building availability and accessibility, consideration should be given to consolidation of test locations and/or land transfers from the Air Force to DOE to accommodate future needs.

The amount of off-site commercial leased space utilized in New Mexico has grown dramatically. While certain types of space (e.g., a hangar for aircraft aging testing) are impractical to duplicate on-site, other types (e.g., offices and light laboratories) can be accommodated. The primary conditions causing some Sandia organizations to move off site are persistent space shortages and impediments to public access presented by the current closed site configuration. The impacts of such moves include both the costs of obtaining and occupying leased space and the dispersion of personnel, leading to increased travel time and a loss of synergy among related organizations and activities. Proposed construction and conversion of the site to better support unclassified public access will help relieve these problems.

## Facilities Maintenance

Sandia's site maintenance plan was prepared in accordance with DOE Order 4330.4A, Maintenance Management Program. The maintenance plan is intended to reduce the maintenance backlog and identify special maintenance requirements likely to impact site missions, functional unit availability, or functional unit material condition. Major cost factors of site maintenance are identified, and site-wide maintenance program costs are summarized. The effectiveness of the site's preventive and predictive maintenance programs is analyzed, as is the site's performance in obtaining maximum useful life from functional units. Improvements to the maintenance program that could lower costs or extend functional unit lifetimes are also discussed.

## Energy Management

Sandia conducts a formal in-house energy management (IHEM) program to adhere to the requirements of DOE Order 4330.2D. The IHEM program is managed by Sandia's Facilities Program Management Center as a part of the Maintenance Management Program Office. The energy program manager reports to the Maintenance Management Program Office and oversees the operation of Sandia's New Mexico, California, and Nevada sites. In addition, an energy conservation coordinator responsible for day-to-day operations has been assigned for each site.

The IHEM program has established a comprehensive energy management plan that maps out the strategy to be used to attain the FY 1995 and FY 2000 efficiency goals set forth in DOE Order 4330.2D. These goals mandate energy efficiency improvements for buildings, metered processes, vehicle fuels, and petroleum use against FY 1985 baseline consumption.

## Condition Assessment

The Sandia Condition Assessment Survey began in FY 1993 using the Condition Assessment Survey and Condition Assessment Information System pilots developed by DOE. The Sandia Condition Assessment Survey uses DOE-supplied manuals and hand-held data collection devices. Prior to condition assessment survey training, the facilities condition inspection method outlined in DOE Order 4330.4A was used to assess the condition of buildings.

During the final two quarters of FY 1992 and the first two quarters of FY 1993, the Infrastructure Assessment Department used the objectives and purposes of the facilities condition inspection to obtain baseline data on the general condition of all Sandia buildings. These data will be used to support the annual Capital Assets Management Program report and will also be used by the Maintenance Management Program Office to identify deficiencies in the maintenance backlog.

## General Purpose Facilities Plans

### General Purpose Plant Requirements

Consistent funding of general plant projects (GPP) is crucial for facility changes, structural improvements, and non-line-item buildings for special programmatic needs and upgrades to meet new standards. Funding requirements are between 1.0 and 1.5 percent of total operating funds. Nearly all of the required funding is provided by the Assistant Secretary for Defense Programs. However, for the 1994 and 1995 fiscal years, Defense Programs

---

funding for GPP has been reduced to \$3 million per year—less than half of what has been provided previously and well below our requirement of \$7 million per year. These reductions will have significant impacts on the implementation of planned site and facilities environment, safety, and health (ES&H), infrastructure, and programmatic projects.

We expect substantial GPP support from the Office of Environmental Restoration and Waste Management to support projects for ES&H compliance. Projected GPP requirements are shown in chapter 13, "Resource Projections."

## General Purpose Equipment Requirements

General Purpose Equipment is used in laboratory administrative and management activities. Funding is provided by applying a surcharge of 10 percent on DOE capital equipment and 0.5 percent on non-DOE funding.

## Inactive Surplus Facilities Plan

To identify surplus facilities, Sandia inventoried its major buildings and their primary missions, then categorized them according to their condition and missions. This process revealed that most buildings house multiple programs that change often. The useful life of a building may be shortened more by mission change than by age or obsolescence.

Buildings judged to be surplus must be substandard or contaminated to such an extent that they are unfit for reuse. Because of the shortage of permanent space in satisfactory condition, any satisfactory space that becomes available through organizational movement or program reductions is quickly filled.

## Facilities Resource Requirements

Some of our laboratories are being upgraded and new ones are being proposed. Several new construction projects address long-standing insufficiencies. Other projects accommodate changing functions and requirements.

Environment, safety, and health (ES&H) concerns are actively addressed in planning for all facilities. Accordingly, all new buildings and major renovations are reviewed internally and by DOE for adequacy of ES&H design features. In the area of environmental protection, DOE now requires that contractors comply with the provisions of the National Environmental Policy Act. This act stipulates that major construction projects be re-

viewed for potential impacts on the environment and for compliance with environmental laws. For each new facility and major renovation, Sandia prepares an environmental checklist/action description memorandum for circulation within DOE. If DOE deems that further documentation is necessary, an environmental assessment or an environmental impact statement is prepared and made available to the public.

Projects required to meet environmental laws, regulations, and DOE orders are included in Sandia's Five-Year Plan for Waste Management Operations and Environmental Restoration. DOE also requires a safety review of new construction projects and major renovations.

Adequate funds are not available to convert to a more cost-effective operation involving unclassified areas. Environmental remediation activities are already placing a serious burden on operating funds. Conversion of portions of our sites to accommodate economic competitiveness and other unclassified activities will require significant investment and should be budgeted and appropriated in line with our evolving integrated site planning.

## Authorized Construction

The principal goals of Sandia's construction plan are to provide facilities needed to achieve programmatic objectives, eliminate substandard conditions, and replace temporary space with permanent facilities. Items listed in the table of major construction projects are briefly discussed below. In addition to these items, a number of major alteration projects with a price range of \$150 thousand to \$4 million are performed using expense funds.

### *Explosive Components Facility (New Mexico)*

Sandia is DOE's technology center for ordnance for nuclear weapon systems. Four of Sandia's departments will utilize the Explosive Components Facility: explosive components, neutronic components, power sources, and weapons evaluation. Facility capabilities include internal test-fire chambers, an x-radiographic diagnostic laboratory, an explosive mild detonating fuze and timer development laboratory, remote postmortem and disassembly areas, and a pulse heat laboratory. A significant feature of the Explosive Components Facility is improved explosives handling and safety.

### *Technology Support Center (New Mexico)*

The Technology Support Center will reduce the Technical Area V population to minimize potential radiation exposures by providing a new office, light laboratory, and conference center for staff who support the reactors. An improved facility is particularly important because Technical Area V receives many visitors as a consequence of its development and testing programs for DOE, the DoD, and other agencies.



---

***Main Electrical Service and Switchgear  
(California)***

The main electrical service and associated switchgear are being upgraded to supply all site power requirements for the foreseeable future. The proposed service is dual-source, separate direction, and will provide backup capability and additional capacity when required.

***Robotics Manufacturing Science and Engineering Laboratory (New Mexico)***

This laboratory will facilitate progress in the development of robotic and automation technologies, which have been identified as strategically important. These technologies will achieve the following objectives: minimize the need to use humans in hostile environments or near potentially hazardous materials; accomplish tasks that stretch normal human capabilities for complexity and reliability; and reduce production and operating costs within both the weapons complex and the domestic industrial sector.

***Investment Casting Addition (New Mexico)***

This addition to the Liquid Metal Processing Laboratory

will provide a safe and efficient investment cast processing operation. The new casting furnace is needed to prove concepts of emerging technologies that will significantly enhance the flexibility of future weapon design/fabrication streams and will reduce the cost of component housing and lead time to complete a casting.

***Nonnuclear Consolidation (New Mexico)***

This project involves renovating space to support the fabrication and assembly of various nonnuclear components of nuclear warheads at Sandia/New Mexico as some DOE production facilities are closed.

***Power Systems Modernization (New Mexico)***

Electrical distribution systems at Sandia/New Mexico are aging and obsolete, as is the series-connected security lighting system. This project includes converting to higher distribution voltage, replacing aging and obsolete transformers and switchgear, and replacing cable as required. It will also replace the remaining series security lighting system and begin replacement of aging master unit substations.

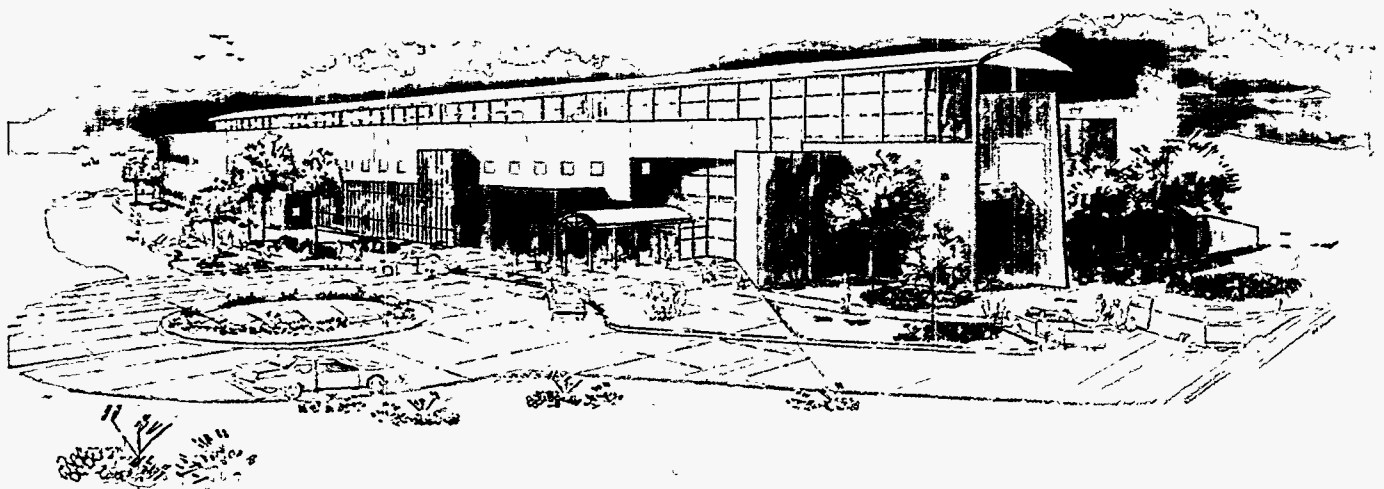

This artist's conception shows the planned Robotic Manufacturing Science and Engineering Laboratory at Sandia/New Mexico, which is scheduled for completion in October 1996.

### ***Center for National Security and Arms Control (New Mexico)***

This facility will bring together work in four areas: systems analysis and advanced concepts; arms control and verification technology; intelligence; and threats and countermeasures. The facility will substantially improve Sandia's ability to respond effectively in these areas.

### ***Combustion Research Facility, Phase II (California)***

This facility will provide resources to adequately deal with the critical combustion research needs of the 1990s. It will emphasize centralized, next-generation laser diagnostic facilities and specially designed laboratories, including a high-repetition-rate laser system. Phase II will also provide additional offices required to support visiting researchers and staff.

## **Proposed Construction**

As part of the last capital assets management program report cycle, all proposed line-item projects were reevaluated for sponsorship and validity in light of evolving DOE missions. The process caused a number of projects to be deleted and several infrastructure projects to be added or moved forward. These projects, described in the FY 1996 Capital Assets Management Process Report and the 1994 Site Development Plan, are included in the table of major construction projects at the end of this chapter.

### ***Processing and Environmental Technologies Laboratory (New Mexico)***

This construction item is part of the nuclear weapons research, development, and testing facilities revitalization project. The laboratory will be used for process technology related to the minimization and management of hazardous materials during nuclear weapons production. Office space will house personnel involved with ES&H compliance and staff support for environmental compliance, transportation of hazardous materials, detoxification, site restoration, and burial of hazardous materials from production. These activities will directly support the DOE nuclear weapons complex reconfiguration program.

### ***Outreach Center (New Mexico)***

This facility will provide DOE and Sandia customers, visitors, and the public direct access to the New Mexico site. It will centralize visitor and public interface activities. The facility will provide appropriate levels of security to safeguard sensitive and proprietary information, accommodate uncleared and foreign visitor meetings, and eliminate visitor confusion created when entering through Kirtland Air Force Base gates. The facility will be highly visible and will provide easy access, ample parking, and welcoming surroundings.

### ***Outreach Center (California)***

This facility will be the focal point for Sandia's interface with industrial and academic partners, provid-

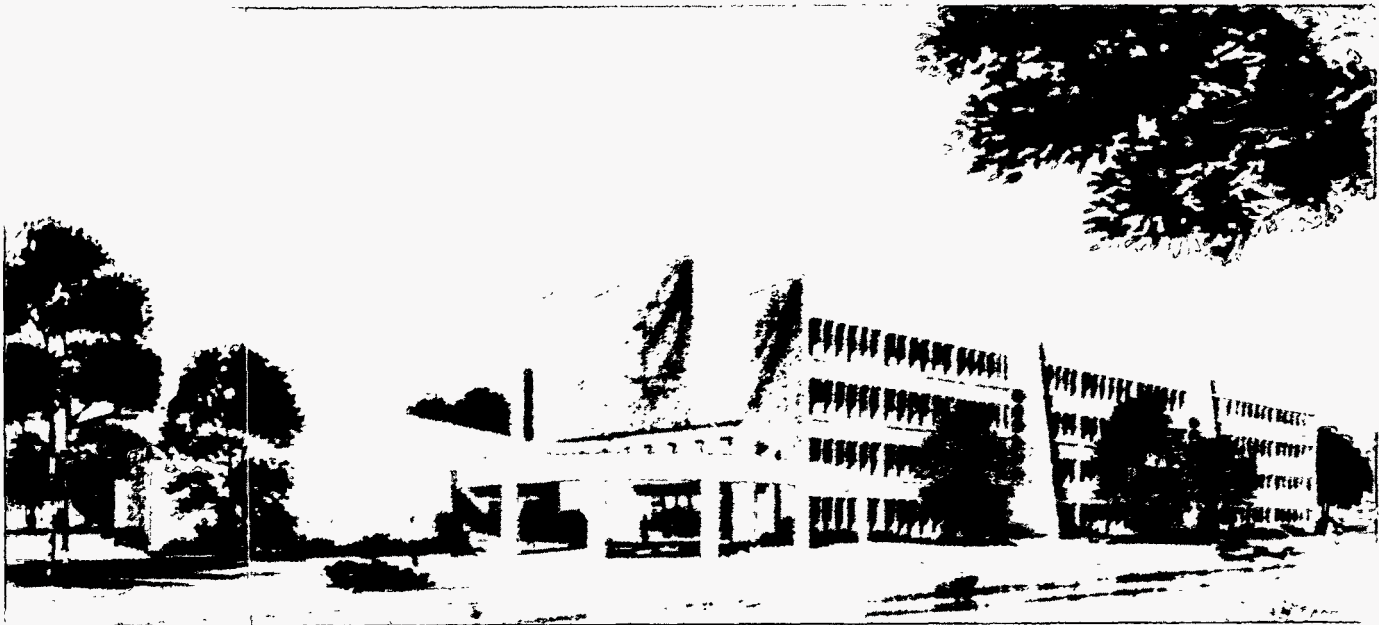

This artist's conception shows the Center for National Security and Arms Control, presently under construction at Sandia/New Mexico.

ing approximately 12,000 square feet of space to house technology transfer and other visitor-related functions. The new building and associated site modifications are a key element of the master plan for an unclassified site.

#### ***Electrical Upgrade/Second Source (New Mexico)***

This project will provide Sandia with a 115-kilovolt transmission system with two separate power sources from the Public Service Company of New Mexico. At present, the only power source is the Sandia switching station on the east side of Kirtland Air Force Base. A second switching station with a 115-kilovolt extension is proposed. During loss of the present Sandia power source, we would be able to transfer all 115-kilovolt loads in Technical Area I to the second source. Currently, power failures at the Sandia switching station leave Technical Area I without power, resulting in lost work time and safety hazards.

#### ***Jupiter X-Ray Simulation Facility (New Mexico)***

This facility will be constructed in response to the moratorium on underground nuclear testing. The facility, designed to simulate nuclear weapon effects in the cold-to-warm x-ray region will replace underground testing and provide a vehicle for advanced weapon physics and x-ray physics research. A fast-track schedule is in place to support operational goals for this project. Facility costs will be shared with the Defense Nuclear Agency.

#### ***Site Infrastructure Modernization (New Mexico)***

This modernization project will improve pedestrian and vehicle circulation and parking throughout the site in support of the site conversion initiative. It will include the following improvements: development of pedestrian corridors to reduce pedestrian/vehicular interaction within the site; creation of distributed, replacement parking for lots now on permitted lands; better access for Sandia and DOE visitors; and extended utility and circulation corridors to the east side, a gateway district of Technical Area I. The gateway district will be the primary location for facilities dedicated to joint projects with our industrial partners.

#### ***Infrastructure Modernization (California)***

This is a multiphase project to renew deteriorated and obsolete site systems. It will also add to the infrastructure of facilities to meet current requirements so that Sandia's mission will not be disrupted.

#### ***Steam and Gas Systems Modernization (New Mexico)***

This project will modernize the steam plant by replacing four old, inefficient boilers with new, larger, and more efficient boilers and upgrading the steam distribution system. The existing gas system will also be extended and looped to accommodate growth.

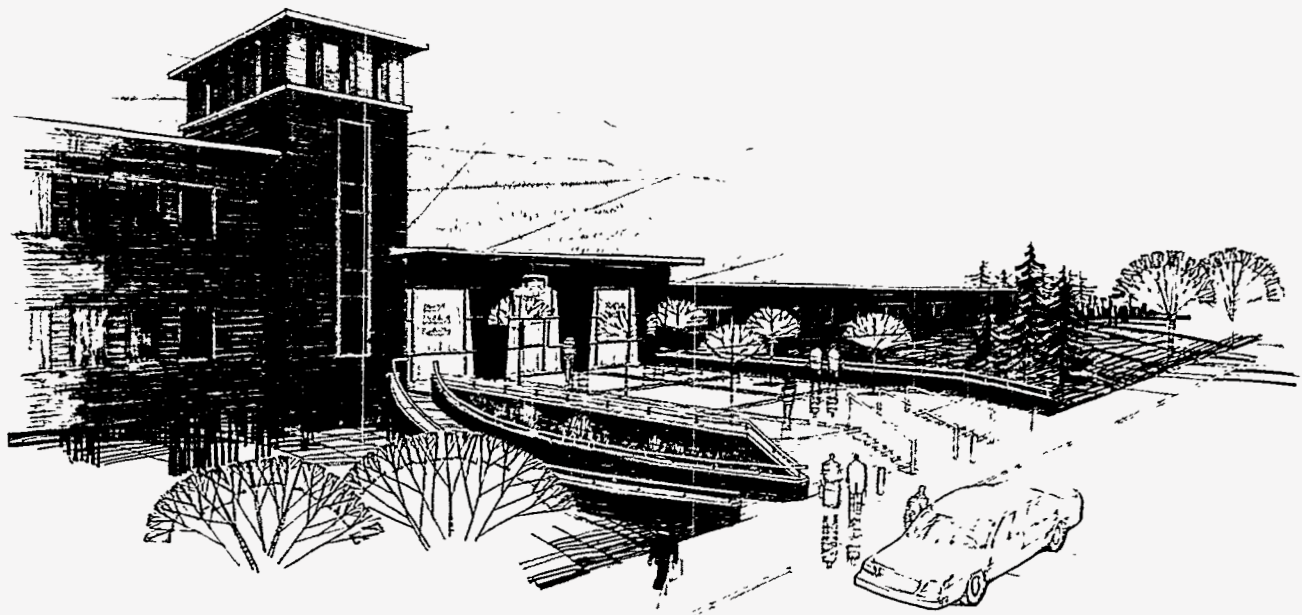

This artist's conception depicts the primary administrative building at Sandia/New Mexico after renovations are completed in 1995.

---

***Laboratory for Industrial and National Security Applications of Computing and Computer-Aided Engineering (New Mexico)***

This laboratory will support Sandia's thrusts in defense and industrial applications of high-performance computing and communications and computer-aided engineering. The laboratory will be a hybrid open/secure facility for dual-use programs.

***Storm and Sanitary Waste Systems Modernization (New Mexico)***

This project will modernize storm drains and sanitary sewers, construct storm water monitoring stations to check for contamination before discharge, and eliminate remaining septic systems.

***Warehouse Complex (New Mexico)***

The warehouse complex will provide approximately 120,000 square feet for storage of classified and unclassified materials and property. It will also include four igloos of approximately 2,000 square feet each for rocket motors and Class-B explosives.

***Reactor and Weapons Test Facility (New Mexico)***

This facility will include assembly and storage bags,

hot cells, and glove boxes. It will provide capabilities for analysis, radiography, and waste handling.

***Consolidated Waste Management Complex (New Mexico)***

This complex will consolidate management activities for hazardous, radioactive, and mixed waste in a framework with the capability to manage all wastes in the most economical and safe manner practicable. The complex will use state-of-the-art robotics technology to perform waste operations and to showcase waste research and development technologies. The complex will also contain a laboratory for waste analysis to determine strategies and final certification.

***Geosciences Research Laboratory (New Mexico)***

This laboratory will provide a unique center for Sandia and the scientific community to study active processes in the earth's crust. The facility will allow Sandia to meet both its research and Drilling Research Office responsibilities in the Continental Scientific Drilling Program. The laboratory will also perform research in fossil and geothermal energy, waste disposal, and seismic verification. The laboratory will accommodate mechanical and geophysical testing of large samples, as well as development and testing of advanced instrumentation.

**MAJOR CONSTRUCTION PROJECTS**  
(Fiscal Year Budget Authority in Millions)

	Site	Sponsor	Total Estimated Cost*	Total Project Cost*	BA thru FY92	FY93	FY94	FY95	FY96	FY97	FY98	FY99	FY00
<b>AUTHORIZED CONSTRUCTION</b>													
Explosive Components Facility	NM	DASMA	27.8	27.9	24.7	3.1							
Technology Support Center	NM	DASMA	30.0	30.2	9.1	8.4	8.5	4.0					
Main Electrical Service & Switchgear	CA	DASMA	5.3	5.3	4.3	1.0							
Robotics Manufacturing Science and Engineering Laboratory	NM	DASMA	33.0	33.3	1.0	6.9	10.1	15.0					
Investment Casting Addition	NM	DASMA	3.7	3.9		3.3	0.6						
Nonnuclear Consolidation	NM	DASMA	70.8	95.3		8.0	2.1	43.5	18.4				
Power Systems Modernization	NM	DASMA	34.3	34.6			4.0	13.0	12.2	5.1			
<b>Total DASMA</b>						30.7	25.3	75.5	30.6	5.1			
Center for National Security and Arms Control	NM	IS	34.5	34.5	16.0	10.0	8.5						
Combustion Research Facility, Phase II	CA	ER	23.7	27.1	4.8			9.4	9.5				
<b>Total Authorized</b>						40.7	33.8	84.9	40.1	5.1			

**PROPOSED CONSTRUCTION**

Processing and Environmental Technologies Laboratory	NM	DASMA	42.6	45.7				1.5	18.0	13.2	8.0	1.9	
New Mexico Outreach Center	NM	DASMA	19.8	19.8					2.5	12.0	5.3		
California Outreach Center	CA	DASMA	5.5	5.5					1.0	4.5			
Electrical Upgrade/2nd Source	NM	DASMA	6.5	6.5					4.0	2.5			
Jupiter X-Ray Simulation Facility**	NM	DASMA	80.0	120.0							20.0	30.0	30.0
Site Infrastructure Modernization	NM	DASMA	15.6	17.3							1.8	3.8	6.0
Site Infrastructure Modernization	CA	DASMA	26.7	27.0							1.4	14.5	10.8
Steam and Gas Modernization	NM	DASMA	4.2	4.2							1.0	3.2	
Laboratory for Industrial and National Security Applications of Computing and Computer-Aided Engineering	NM	DASMA	50.0	50.3							1.1	16.0	17.0
Storm and Sanitary Waste Systems Modernization	NM	DASMA	10.5	10.6								2.1	6.0
Warehouse Complex	NM	DASMA	13.0	12.3								1.0	12.0
Reactor and Weapons Test Facility	NM	DASMA	50.0	50.0									4.0
<b>Total DASMA</b>								1.5	25.5	57.5	83.9	87.7	
Consolidated Waste Management Complex	NM	EM	30.0	105.0						3.0	7.0	10.0	10.0
Geosciences Research Laboratory	NM	ER	27.6	27.6							1.6	12.0	9.0
<b>Total Proposed</b>								1.5	28.5	66.1	105.9	106.7	

\*Total estimated costs and total project costs for FY1995 projects and beyond include burdened costs.

\*\* The Defense Nuclear Agency portion is not included.



## 10 • Information Resources Management

### Information Resources Management Goals, Objectives, and Strategies

In 1994, Sandia established a Chief Information Officer, who will report directly to the Sandia Executive Vice President. The new chief officer and his organization will consolidate all activities associated with information management throughout Sandia. Organizations previously performing some aspect of this function are now being coordinated by an information architecture team. The office's major functional areas include the following: information processes (data modeling, standards, etc.); applications development (business systems, property, procurement, etc.); information services (electronic mail, help desk, local area network management, etc.); and computing and communication systems (mainframes, servers, telecommunications, etc.).

An advisory group will be formed of users and managers to provide Sandia-wide guidance to the information office. User support will be provided by a central computing help desk, a financial information systems user's group, and a computing newsletter. Quarterly reviews will be held.

Long-term planning has two major focuses. First, the information architecture group will define Sandia's approach to a corporate information network, company-wide access, and external access. Second, budgeting is under way and program plans are being prepared on costs through FY 1997.

This organization's goal is to build a coherent information infrastructure and to manage information as a corporate asset. Corporate information will be stored in data servers readily accessible via personal computers and work stations throughout Sandia. Some information will be available as utility services (e.g., electronic mail). Other information will be available on a charge-back basis.

---

## Information Resources Environment

### Computational Facilities

#### Scientific Computing Resources

Sandia's supercomputers include large vector architecture machines (e.g., the Cray Y-MP systems) and a growing number of massively parallel systems. Supercomputers are used primarily for solving large scientific and engineering problems. Applications include materials studies, nuclear safety calculations, particle-beam calculations (for pulsed power and other research), weapon systems development, missile defense and countermeasure analyses, facilities vulnerability analyses, and combustion chemistry. Supercomputers allow us to model three-dimensional effects and perform increasingly higher-resolution approximations.

In order to accommodate the computational demands of its missions, Sandia has developed a number of interlinked networks of computers based upon increasingly more capable communications. Desktop computers and workstations are linked with central systems through reliable, high-speed networks. Ethernets and fiber distributed data interface rings are the preferred local area network technologies at Sandia. Higher-speed dedicated lines are used for special applications; fiber distributed data interface rings are used to connect centrally residing systems. Asynchronous transfer mode switches and synchronous optical network technologies are being investigated as promising network technologies.

The major delineation in the networking realm is the separation of secure (classified) and restricted (unclassified) computing resources. Individual computer systems reside in one or the other of these domains. The secure domain is capable of processing classified information through secret restricted data.

Sandia supercomputer systems have been consolidated at the New Mexico site. Data communication capabilities are available at 45 megabits per second to facilitate use of these systems by staff in New Mexico and California. The secure network houses a Cray Y-MP8/264 and a two-terabyte network storage service. These machines are linked to other systems within the secure partition. The restricted network houses a Cray Y-MP/864. A terabyte file server will be acquired to support this system. California has central file storage to facilitate data caching for local access.

Massively parallel systems are also on the unclassified network and are accessible to our industrial partners. In this network we currently have a 1,024-node nCUBE with four gigabytes of memory operating at a peak rate of 2.5 gigaflops, two 64-node Intel iPSC/860s with a peak rating of 3.8 gigaflops, and an Intel Paragon with 1,827 nodes

operating at a peak rating of 130 gigaflops.

Sandia's scientific computing acquisitions during the FY 1995 through 2000 time frame are intended to dramatically increase computational power and simulation capability and improve the performance of support servers both at the central facility and within distributed local area networks. Plans are also being implemented to bring Sandia's network technology into the gigabit range during this time frame. Early in the planning period, massively parallel systems will become the major computer servers.

We plan to implement leading-edge, industry-supported standards in all of our computing environments. Therefore, we will conduct integrated research in communications, networking, algorithm development, and computing technologies to lead in the development and establishment of such standards.

This effort will require many collaborations with industry and other national laboratories. Several cooperative agreements are already in place. By integrating fiber optics, asynchronous transfer mode protocols, synchronous optical network technology, scientific algorithms, and massively parallel systems, it will be possible to create a computing environment that will allow customers to solve a vast array of engineering and scientific problems and visualize results quickly. The advent of asynchronous transfer modes and similar technologies will also permit distributed workstations to be clustered as a single logical resource. Ultimately, it will be possible for a customer to log onto a network and use any tool required.

#### Computer-Aided Engineering

Computer-aided engineering (CAE) is an important element supporting Sandia's responsibilities for product design through manufacturing processes. Sandia has demonstrated capabilities in the management of major projects supporting pioneering efforts in computer-aided design and manufacturing. Accordingly, DOE designated Sandia as the lead laboratory for the Computer-Integrated Manufacturing (CIM) Program within the Office of Military Application. An integrated CAE capability is the primary focus of the CIM Program. CAE initiatives have been assigned to the Engineering Integration Center.

A fully integrated CAE capability should contain all necessary elements for the creation, management, and distribution of information supporting the design, analysis, definition, manufacture, and acceptance of a product, including product life-cycle information. The Engineering Integration Center contributes in the two primary areas of creation and information management.

Information is created via two primary projects: NIRVANA and ACCORD. The NIRVANA project provides the required CAE features supporting electrical product design. The ACCORD project supports mechanical

---

products. Both projects involve participation from a number of line organizations at both Sandia locations and at Allied-Signal's Kansas City Division.

The NIRVANA project was based on the concept of a standard design environment using a common set of tools and processes. The NIRVANA implementation plan includes periodic system upgrade or replacement as new technology becomes available. With this approach, the design environment remains constant because all using sites will migrate uniformly to the new environment. The ACCORD project objective was to select the next generation system supporting mechanical design for use within the weapons complex. The system is based on a parametric, feature-based solid modeler that is the foundation for the various processes. Similar to the NIRVANA project, the design environment will be periodically upgraded to reflect newer technologies or processes.

Information management covers a range of responsibilities, including development of new systems and maintenance of older systems while applying the latest technologies (such as language-based information modeling processes and automatic code generation). The challenge is to minimize the number and types of information systems, remain affordable, and satisfy customer needs. Two examples of success in this area are the Configuration Management System (CMS) and the Image Management System (IMS).

Output information from CAE tools is managed by CMS, which was developed during FY93 and implemented at the start of FY94. CMS is being integrated to serve both the New Mexico and California sites. IMS serves as a long-term archival information storage system for design information and allows user access from New Mexico, California, and Allied-Signal in Kansas City.

The integration of these related elements of CAE have the potential to provide significant improvement to the design-through-manufacturing process. However, realizing the full potential of these capabilities will require major change to our business and design processes, as well as interfaces with our business partners.

## Administrative Information Systems

Administrative information systems ensure that Sandia can operate as a successful business entity. Administrative application projects are managed under the information services program and sponsored by the Administrative Management Council. Projects are identified, selected, and prioritized by the Extended Computer Advisory Committee. Projects are typically accomplished by teams using system approaches such as the System Development Methodology (AGS Management Systems), the Information Engineering Facility (Texas Instruments), and the Product Set (Bachman Reengineering). Systems are developed with customer participation in joint application design sessions and via

iterative prototyping techniques. Current projects include enhancement of the financial information system, Phase 2 development of the Sandia reimbursement and vouchering system, the library information on-line network, and electronic time-keeping.

Separate but related project activities exist in developing messaging services. These include electronic mail messaging, enhancement of the voice mail system, and development of applications for voice and electronic mail. Work continues on voice applications such as the invoice processing application that provides statuses to our suppliers by telephone. Messaging activities will be expanded in FY 1995 by developing applications that conform to electronic data interchange standards and connecting to Sandia's external vendors, reducing the cycle time of major corporate processes.

Production-related activities such as scheduling, systems support, operations, help desk services, and data administration are provided under full cost recovery through the Administrative Computing Service Center. Cost pools are being developed for each hardware platform and accounting transactions are being established in the service center information system to automate cost recovery of usage-based and fixed-price services. All central computing facility machines operate twenty-four hours a day, seven days a week.

All centralized information systems now reside primarily on an IBM model ES9021-620, the laboratory information system. These applications run under the multiple virtual storage operating system and IBM's DB2 database management product. Applications include human resources, payroll, financial services, property, and procurement.

Three smaller IBM processors continue to provide other services. An IBM model 4381 runs IBM's office vision product under the virtual machine operating system and provides electronic mail services and routing. Another IBM model 4381 running under the virtual machine operating system provides detailed personnel information through the personnel reporting system. The classified information system is an IBM model ES9121-190 that runs under the multiple virtual storage operating system and provides an environment for classified engineering and administrative applications. Applications on the classified information system support records of assembly, the technical library, engineering documentation, and document accountability. Applications currently residing on these IBM machines are candidates for movement to a client-server architecture based upon the results of cost/benefit studies. The two machines running under the virtual machine operating system are also candidates for consolidation.

Our goal for administrative information systems is improved competitiveness through a hardware and software environment that anticipates customer needs. Two initiatives are already under way. We are conducting an external benchmark of the data center and we have



formed an architecture team to explore the adaptability of the framework used by commercial information services.

Based upon an environmental scan and strategic planning involving major customers, we envision an expanded partnership with customers to provide solutions. An important strategic goal is greater accessibility of administrative data from customers' desktops. To achieve this, we plan to introduce a client-server architecture, provide greater leverage of software tools between the mainframe and desktop environments, and use object-oriented methodologies to improve quality and reduce delivery time. We also plan to provide increased training to line organizations in using administrative information systems to better conduct their business.

## Telecommunications

### Data Communications

The emphasis on parallel computing, outside collaboration, consolidation, technology transfer, total quality management, and environmental safety and health management makes data communications vital to Sandia's future. A variety of technologies are being investigated and deployed, including fiber optic cables to the desk, very-high-speed local area networks, modern broadband switches, high-speed intersite links, video teleconference facilities, and modern network management systems.

Sandia's recent initiatives require unclassified communications but our traditional mission demands secure communications.

Sandia operates an extensive internal secure communications system. A large customer base receives services ranging from asynchronous terminal access through 100-megabit fiber distributed data interface support. Numerous intersite links to a variety of DOE and DoD facilities exist, as do video teleconferencing capabilities to several DOE facilities.

Sandia's Engineering Science Center moved to a refurbished building last year. As part of the move, we installed an extensive, state-of-the-art, optical-fiber distribution system to every desk in the new facility. Although full-bandwidth Ethernet on optical fiber will initially be installed, the distribution system will support fiber distributed data interface local area networks and video. This distribution system and the high-speed networks are a model for several other facilities at Sandia's New Mexico location.

An architecture that consists of T3 (45-megabit-per-second) intersite links, asynchronous transfer mode switches, switched multimegabit data service protocols, and high-performance routers was implemented as part

of Sandia's plan to locate all of its supercomputers at Albuquerque. This architecture is the standard for high-speed networking at Sandia. We are also a participant in the AT&T-sponsored experimental university network, which is a test bed for cross-country gigabit networking.

These activities will bring Sandia's data communications infrastructure up to the state of the art. The technical excellence and commitment to quality of Sandia's networking and communications staff are evinced by a number of recent accolades, including a Research and Development 100 award, "best paper" at the NEXUS 90 and NEXUS 91 conferences, the 1991 INTEROP achievement award in the government sector, the Enterprise Network Award of Excellence in 1993, and several patents.

### Voice Communications

In the past, the Kirtland Air Force Base Communications Squadron provided telephone service for Sandia's New Mexico site and for all other Kirtland Air Force Base tenants. However, recognizing the importance of telecommunications service to corporate existence, Sandia assumed direct responsibility for providing state-of-the-art services in 1993. Sandia moved and expanded the AT&T 5ESS digital electronic switch to form the cornerstone of its voice and unclassified data telecommunications services. This switch provides enhanced digital



Sandia employees can now meet "face-to-face" with colleagues anywhere in the world through video conferencing teleports. Here, four Sandians at Livermore and two on-screen from Albuquerque demonstrate videolink capabilities between Sandia's two main sites.

voice, video, and data services using integrated services digital networks.

The Sandia 5ESS switch consists of a host system and optical remote modules to service the Laboratories' remote areas. We constructed a building for the host 5ESS switch and we upgraded conduit systems to provide customer access. Approximately 1,200 lines are in service on the first optical remote module, and more than 10,000 lines are in service on the 5ESS host, which also serves other DOE facilities on Kirtland Air Force Base (the Albuquerque Operations Office, the Inhalation Toxicology Research Institute, EG&G, and Ross Aviation).

Sandia/California operates an AT&T 5ESS switch for its unclassified voice/data communications. The 5ESS is an integrated services digital network switch capable of handling voice, data, and signaling information over the same line. It provides access to Federal Telecommunications System 2000 and the commercial network for long-distance communications.

The Tonopah Test Range local voice telecommunications system terminates in a Northern Telecom SL-1 switch with twenty-four trunks to the SL-100 switch at the DOE Nevada Operations Office. Tonopah Test Range personnel use the Federal Telecommunications System and the Nevada Test Site tie-line network for most of their long-distance telephone requirements.

A Motorola radio trunking system (selected by competitive bid) was installed at Sandia/New Mexico in 1991. It is a basic five-channel system that will be expanded as users are moved to the system from their current frequencies. The basic system has a capacity of approximately six-hundred radio users. The site currently has about 2,200 radio transceivers in use.

Radio networks on the trunking system include the motor pool, transportation and storage, and reclamation services. The radio frequencies in use by these organizations are available for other uses. As funding becomes available, most other services (plant maintenance, safety, emergency operations, and health physics) will have their radio communications transferred to the trunking system.

When fully implemented, the trunked radio system will become a part of Sandia's national security emergency preparedness communications system. It will fulfill emergency communications requirements mandated by the specification for emergency operations centers in the DOE Albuquerque Operations Office Complex.

## Records Management

Records management entails planning, organizing, training, and other managerial activities related to the creation, maintenance, use, and disposition of records. Thus, records management provides the right record to

the right person at the right time for the right cost.

The records management program at Sandia supports core research functions and laboratory operations by improving management of information resources. The records management program fosters an understanding of the importance of recorded information generated by Sandia staff and subcontractors, teaches Sandians their responsibility in the creation, use, maintenance, and disposition of records, and explains the federal government's role in information management at Sandia.

The records management program assists line organizations in constructing manual and automated systems for timely and cost-effective information retrieval and document tracking, and also guides line organizations in cost- and mission-effective management of information throughout its life cycle (creation, distribution, maintenance, and destruction or long-term preservation). A Sandia-wide records retention schedule is being developed to identify unique records, assign responsibility for such records, and indicate when and how such records may be disposed (i.e., destruction or transfer to corporate archives).

Sandia's records management program and retention guidelines ensure compliance with regulatory requirements. Virtually all records held by Sandia are treated as government property and are subject to federal statutes and regulations, including those found in the US Code, the Code of Federal Regulations, DOE orders, our prime contract, requirements specific to particular Sandia projects, and other regulatory requirements imposed by various government agencies.

The records management system reviews line organization information management procedures for adherence to good business practices and compliance with regulatory requirements. The records management system also provides leadership and partnering activities that

- facilitate the integration of information services by teaming with other information resource providers;
- preserve and make available Sandia's corporate memory and evidence of Sandia's service in the national interest;
- work with nuclear weapons complex design agency and production agency engineers to ensure that records to support changing mission assignments of nuclear weapons component production during reconfiguration remain available to Sandia product engineers and stockpile evaluation engineers; and
- assist DOE in identifying, preserving, and improving document retrievability of weapon data vital to the national defense.

In accordance with the next-to-last item above, a

---

records management activity transfer group has been identifying production-related records at the Pinellas, Mound, and Rocky Flats plants that need to be transferred to Sandia, Kansas City, and Los Alamos. Records personnel from each of these sites, from DOE Headquarters, and from corresponding DOE field offices have met a number of times to determine the best means of transferring the records. A Sandia records transfer assessment team is now determining which Pinellas records will be needed at Sandia. This team includes Sandia systems engineers, manufacturing development engineers, stockpile evaluation engineers, reliability and surety engineers, quality assurance engineers, and standards and calibrations engineers. The team also includes Sandia procurement and corporate records management personnel and representatives from Pinellas. The records transfer assessment team plans to move identified information from Pinellas to Sandia by the end of CY 1994.

## Management of Scientific and Technical Information

Sandia established the Scientific and Technical Information Management Program to protect the public's interest in research performed at Sandia. Scientific and technical information encompasses all aspects of work at Sandia, including some administrative, financial, and environmental safety and health efforts. Because such

work is largely funded by government expenditures the public has a considerable interest and investment in Sandia's operations. More specifically, the public has legitimate concerns that

- technical staff manage scientific and technical information to facilitate their continued success in research and promote cost- and mission-effective operations;
- results and progress on all significant scientific efforts are reported to DOE so that results and findings may be made available to appropriate individuals in the research community;
- research staff control the dissemination of information to protect national security interests;
- technical staff generate adequate documentation of their work to assure accountability and to protect against fraud, waste, and abuse.

Sandia addresses these concerns through its Scientific and Technical Information Management Program. The program trains staff about their role in generating information needed to document their research efforts and in their responsibility as custodian of such documentation. Sandia and DOE have formal review and approval processes to ensure that scientific and technical information has undergone required reviews prior to external release.



## 11 • Environment, Safety, and Health Management

Sandia is committed to protecting the environment and preserving the health and safety of individuals and the community. We conduct a comprehensive program to ensure that operations are at the leading edge of industry standards and that Sandia is in compliance with all applicable laws and regulations on environment, safety, and health (ES&H). Sandia's program has been structured to address environmental issues in a timely fashion, thereby maintaining public confidence in our ability to conduct operations without harming the environment. A major part of our vision is to be considered a leader within the DOE complex by being an example of a safe and healthful workplace.

### ES&H Program Goals and Objectives

Sandia's ES&H program is designed to:

- make Sandia a safe, healthful, and environmentally sensitive workplace;
- comply with applicable laws, orders, and regulations; and

- demonstrate this capability to DOE and the public.

Seven objectives support achievement of the three goals. These objectives employ both long- and short-term strategies.

#### *Objective One*

Our first objective is to ensure safe and healthful workplaces for our employees, contractors, visitors, and communities.

This requires compliance with applicable laws and regulations. DOE orders, directives, and requests are also requirements directed toward meeting this objective.

#### *Objective Two*

Our second objective is to use the Sandia quality process to continually strive for a responsible ES&H program and to meet our customers' requirements.

Sandia will continue to employ total quality management methodologies for all ES&H activities. Such methodologies will be used for identifying, developing, and improving necessary ES&H processes, correcting root causes of ES&H problems, and applying lessons learned from Sandia and DOE experiences. Sandia's total quality management initiative establishes an overarching

---

implementation strategy for all of our activities, including those in the ES&H program.

### **Objective Three**

Our third objective is open, timely communication of ES&H problems, lessons learned, plans, and status to achieve appropriate, uniform actions throughout Sandia.

We continue to enhance communications on ES&H issues both to Sandia's ES&H professionals and to other staff. Current communications on new requirements are achieved through a working group representing all Sandia divisions and bargaining units, through lessons-learned processes, and through training courses. Sandia has also established procedures whereby any employee may anonymously express an ES&H-related concern or report an ES&H-related problem or condition.

### **Objective Four**

Our fourth objective is to team Sandia employees, customers, suppliers, and community representatives to strongly promote protection of the environment and the safety and health of all.

Our goal is to use the capabilities of all staff in ES&H activities. Current cross-organizational projects are under way with staff having expertise in materials, instrumentation, geoscience, and field operations. Interactions with universities and high schools occur through temporary employment of students, Sandia participation in the university-based Waste-Management Education and Research Consortium, and contacts with teachers and students in classrooms. Sandians serve in various state and local government organizations, and staff from Sandia's ES&H organizations interact formally and informally with regulatory agencies.

### **Objective Five**

Our fifth objective is to manage ES&H risks and hazards through formal, established processes in conjunction with an active awareness of ES&H by every Sandian.

A key step in identifying hazards is the preliminary hazard assessment (PHA) that line organizations must complete for all facilities and activities. The PHA identifies all hazards in the workplace. ES&H standard operating procedures (SOPs) describe processes to control the hazards identified in the PHA. ES&H SOPs are used by one or more organizations, and must include the following:

- responsibilities,
- specific training and experience requirements,
- waste management requirements, and
- hazard identification and mitigation.

ES&H operating procedures are written and owned by organizations conducting operations. Operating procedures provide step-by-step instructions for specific operations (normal, postulated abnormal, and emergen-

cy) to ensure that activities are performed correctly, safely, and consistently.

To assist in a graded approach in management of risks, all PHAs are assigned a preliminary hazard classification (PHC) and all activities are assigned a programmatic risk classification (PRC). The PHC and PRC values are used as guidance in establishing the appropriate level of rigor with which a facility or activity is managed and when facilities or activities are reviewed by upper management. Additionally, the PHC ratings establish both Sandia corporate and DOE understanding of the relative hazard level of all Sandia facilities.

### **Objective Six**

Our sixth objective is to support our employees in personalizing Sandia's ES&H awareness at work and at home.

The Laboratories will continue disseminating ES&H information helpful to Sandians' families via such publications as the *Total Life Concept Newsletter* and the *Harvard Medical School Newsletter*. Sandia has a process for recognizing and rewarding outstanding ES&H contributions.

### **Objective Seven**

Our seventh objective is to ensure that every Sandian has necessary ES&H training, and to ensure that visitors and contractors comply with Sandia's ES&H requirements.

We maintain a records system for tracking ES&H training requirements and the training status of employees. Experts from Sandia line organizations are involved in developing and improving corporate and organization-specific training courses. Trainers teach additional trainers where possible to allow staff to instruct their own organizations in good ES&H practices. Management is responsible for ensuring that all visitors and contractors in their areas receive training about the presence of hazards and protection from those hazards.

## **Regulatory Environment**

### **Laws and Regulations**

There are many federal environmental laws and implementing regulations with which Sandia must comply. These laws and regulations include the following: the Clean Air Act; the Clean Water Act; the Resource Conservation and Recovery Act; the Federal Insecticide, Fungicide, and Rodenticide Act; the Toxic Substance Control Act; the Comprehensive Environmental Response, Compensation, and Liability Act; the Safe Drinking Water Act; the Oil Pollution Control Act; the Marine Protection, Research, and Sanctuaries Act; and the Noise Control Act of 1973. In ad-

dition, DOE is promulgating and implementing the following regulatory requirements via publication in the Code of Federal Regulations (CFR): Quality Assurance (10 CFR 830.120); Radiation Protection of the Public and Environment (10 CFR 834); and Occupational Radiation Protection (10 CFR 835). These rules will be enforced through the Price-Anderson Amendments Act of 1988. Sandia is developing a strategy for achieving compliance with all rules related to the Price-Anderson Amendments Act.

DOE orders implement other federal laws affecting Sandia, including the National Environmental Policy Act, the Occupational Safety and Health Act of 1970, the National Historic Preservation Act, the Coastal Zone Management Act of 1972, and the Mine Safety and Health Act. The contract for the operation of Sandia National Laboratories by the Sandia Corporation requires that Sandia's ES&H operations be conducted in accordance with all applicable DOE orders and directives communicated to Sandia by the DOE contracting officer.

The Defense Nuclear Facilities Safety Board through its recommendation to the Secretary of Energy focused emphasis on a select subset of these contractual orders. This prompted an effort to perform facility-specific order compliance self-assessments at Sandia's nuclear facilities. These facilities are grouped into reactor operations, Technical Area V operations, and the Manzano storage facilities, with specific plans for each group. Self assessments are scheduled for completion in September 1995. Sandia is implementing an institutionalization process for self assessments of requirements on a facility-specific and site-wide basis. This includes new requirements (e.g., new DOE orders), revised requirements, or reassessment of requirements based on an established schedule. Criteria are being developed to determine risk categories of requirements to guide the level of rigor applied. Sandia's goal is to extend these criteria to all contractual orders and eventually to incorporate all requirements identified by the Standards/Requirements Identification Document.

To ensure that resources are used where they will add the most benefit, Sandia is applying a graded approach to the formal requirements of DOE Order 5480.19 (Conduct of Operations) and DOE Order 5700.6C (Quality Assurance). All of Sandia's nuclear facilities and high hazard operations and facilities must strictly comply with applicable DOE requirements. For the rest of Sandia's activities, quality assurance and conduct of operations are at present implemented through Sandia's Management Integration and Implementation Project. The Laboratory Process Reengineering effort, a formal redevelopment of all Sandia administrative and technical work processes, provides a unique opportunity to further inculcate the principles of quality assurance and conduct of operations in Sandia work processes. Eventually, activities at all Sandia sites will use these standard work processes to ensure consistency, efficiency, reliability, and accountability. As funding permits, Sandia is working on a data

base for the seismic implementation plan required by DOE Order 5480.28 (Natural Phenomena Hazards Implementation Plan).

Sandia must also comply with state and local legislation applying to laboratory sites in New Mexico, California, Nevada, Hawaii, and diverse field locations in the United States and other countries. Such legislation in New Mexico includes the New Mexico Air Quality Control Act, the Environmental Compliance Act, the Water Quality Act, the Hazardous Waste Act, and the Solid Waste Act. In addition, there are local regulations for air quality and sewage pretreatment.

Applicable legislation in California includes the California Clean Water Act, the Air Toxics "Hot Spots" Information and Assessment Act, and the Tanner Act. Sandia's California site must also comply with local regulations such as Bay Area Air Quality Management District rules. Similar laws in Nevada and Hawaii affect Tonopah Test Range and the Kauai Test Facility.

An example of cooperation between Sandia and environmental agencies is the 1990 Agreement in Principle between the States of New Mexico and California and DOE to monitor cleanup and environmental activities. The agreements were the result of a 1989 initiative by the governors of several states with DOE nuclear facilities. The agreements give state officials access to DOE facilities to monitor (but not to regulate) cleanup operations. Under this agreement, New Mexico's Environmental Department has five full-time employees stationed at Sandia/New Mexico. DOE provides about \$3 million per year to the state for staff and equipment for this on-site monitoring at DOE sites in New Mexico.

## Sandia ES&H Requirements Documents

The contract between Sandia's operating contractor and DOE specifies that Sandia National Laboratories will comply with all applicable federal, state, and local laws and regulations and all applicable DOE directives.

Requirements from laws, regulations, DOE orders, and other documents pertaining to ES&H are forwarded to the appropriate ES&H operations center for action. The appropriate director assigns an order expert, who determines whether laboratory ES&H documents need to be amended or a new document written. If action is necessary, the document owner becomes involved. If requested, the Line Implementation Working Group assists in developing implementation approaches. This assures that requirements are identified, assigned to an individual, tracked, assessed for effectiveness, and monitored for compliance.

Requirements are translated into specific actions delineated in Sandia ES&H requirements documents. The first of these documents is Sandia Laboratories Policy

2001 (Environment, Safety, and Health), which defines ES&H policy. This document defines a hierarchy of ES&H requirements documents through which requirements flow from sources (i.e., laws, regulations, and DOE orders) to Sandia employees, on-site contractors, and visitors. Documents such as preliminary hazard assessments, safety assessments, safety analysis reports, and plans for achieving compliance, augment the documents in the hierarchy.

Sandia's *ES&H Manual* provides guidance and compliance tools and interprets/condenses requirements for use by line management to help ensure

- the safety and health of employees, on-site contractors, and the general public,
- the preservation of the environment, and
- the performance of work activities in compliance with applicable laws, regulations, DOE orders, and best management practices.

The requirements in the *ES&H Manual* and its supplements are implemented by Sandia organizations.

The legal and regulatory environment affecting Sandia's ES&H activities is likely to remain dynamic as public concerns and government administrations evolve. For example, the Federal Facilities Compliance Act of 1992 clarified the ability of the Environmental Protection Agency and states to enforce hazardous waste regulations at federal facilities such as Sandia. We anticipate a general trend of laws and regulations requiring more attention to procedures, processes, and documentation to ensure a greater degree of auditability in environmental compliance.

## ES&H Policies, Organization, and Management

This following is extracted from the policy stated in Sandia's *ES&H Manual, Volume I: Environment, Safety, & Health* (page 1A-1).

Sandia National Laboratories considers the protection and preservation of the environment and safety and health of its personnel, contractors, visitors, and the public to be critical to its success.

Accordingly, Sandia personnel design products, develop manufacturing processes, and conduct operations while encouraging recycling, waste minimization, and reduction of the use of hazardous materials. Sandians also ensure the protection of people and the environment while complying with applicable federal, state, and local laws and regulations, agreements, consent decrees, and DOE directives.

Sandia employees who oversee contractors and who host site visitors assure that they are adequately informed of this policy and of their obligation to comply with it. In addition, Sandia continuously evaluates regulatory requirements, corporate policies, customer needs, and lessons learned, and adjusts its operations to meet these changing needs in seeking to continuously improve ES&H processes.

Matters pertaining to environment, safety, and health are the responsibility of all Sandia employees, contractors, and visitors. All Sandians are expected to abide by the following credo: No job is more important than your health, your safety, and the protection of our environment.

The president of Sandia National Laboratories has overall responsibility for ES&H. He is advised on ES&H matters by the Sandia Quality Leadership Council, which he chairs. The directors of the Sites Planning and Integration Center, the Sites Operations Center, the New Mexico Safety and Health Center, and the New Mexico Environmental Operations Center report to the Vice President of Laboratory Services. The directors of the New Mexico Medical Center, the manager of the California Medical Department, and the director of the California Security, Facilities, and ES&H Center report to their respective vice presidents. The directors of the centers responsible for ES&H-related functions have overall management of Sandia's ES&H activities.

ES&H professionals at both the New Mexico and California sites support Sandia organizations in improving the safety of work activities. This support includes:

- occupational medicine,
- industrial hygiene,
- radiation protection,
- safety engineering, and
- fire, electrical, and building codes integration.

The Environmental Operations Center at Sandia/New Mexico and the Security, Facilities, and ES&H Center at Sandia/California are responsible for managing Sandia's environmental restoration projects by ensuring that all permit requirements are met and by working with federal and local environmental regulators. Environmental restoration and waste management activities are coordinated with the DOE Office of Environmental Restoration and Waste Management through Sandia's Energy and Environment programs sector.

Independent internal assessments are performed and each level of management provides periodic self assessments of its own operations.

Each of Sandia's corporate divisions is responsible for

the ES&H activities in its area. Every division has a designated ES&H coordinator who works closely with the ES&H centers at New Mexico and California to ensure that effective ES&H processes are incorporated into the programs. Each division ES&H coordinator also serves on the Line Implementation Working Group. In addition, all of Sandia's center directors (who report to division vice presidents) have designated ES&H coordinators who are available to work directly with researchers doing studies of ES&H issues. Each level of management is responsible for oversight and assessment of its own ES&H processes to ensure safe operations and to comply with requirements.

## ES&H Plans and Initiatives

The DOE ES&H Tiger Team assessments of Sandia/California in 1990 and Sandia/New Mexico in 1991 led to major changes in Sandia's ES&H effort, including significant increases in financial and human resources. Emphasis on compliance with DOE orders and directives resulted in major restructuring of ES&H activities. Formal processes are in place or being developed to achieve compliance and to accommodate expanding requirements.

Sandia manages all ES&H activities on the basis of risk assessment. The Integrated Services Management Plan contains processes to identify, describe, and prioritize work based on averted risk and benefit to Sandia. These processes ensure that the limited resources available are used for activities that have the greatest benefits and averted risks. Emphasis is placed on working more efficiently and effectively by better understanding customer requirements and by eliminating redundant activities. These processes are reflected in the input to the DOE ES&H Management Plan.

A laboratory-wide ES&H strategic plan will provide direction for further improvements. The plan will emphasize the safety and health of employees, contractors, visitors, and residents in surrounding communities. ES&H responsibilities will be increasingly assumed by Sandia line organizations as a part of their normal operations.

ES&H training is operated as a service center. Prioritization processes are being implemented to focus training resources on areas of greatest importance. Training intensity will increase as greater emphasis is placed on performance-based and on-the-job training.

Changes in DOE programs and Sandia management initiatives will influence the direction of ES&H activities. The growing number of requirements and requests during this period of diminishing budgets requires a strong prioritization system to identify critical activities. Regulatory inconsistencies among federal, state, and local agencies will continue to require resources for resolution. We are improving our processes for handling the diverse

ES&H requirements at our permanent facilities as well as at many field operational sites throughout the world.

ES&H activities at Sandia fall into four major categories of sponsorship and funding:

1. The DOE Office of Environmental Restoration and Waste Management directly funds specific environmental restoration and waste management projects. Program plans and budgets are defined directly with DOE through Sandia's Energy and Environment programs sector.
2. The core activities of Sandia's ES&H program are funded through indirect budget under the management of Sandia's Administrative Management Committee.
3. DOE Defense Programs has the "landlord" responsibility for Sandia. Accordingly, Defense Programs provides support to upgrade facilities for ES&H compliance. This funding source will not be available after FY 1994.
4. Individual projects support ES&H professionals directly for services unique to their operations. This budget also supports the ES&H service centers.

## ES&H Work for the Office of Environmental Restoration and Waste Management (EM)

The DOE Office of Environmental Restoration and Waste Management oversees research and technology development programs for environmental cleanup and waste management (including the Waste Isolation Pilot Plant). A portion of this funding is for Sandia operations and is managed as part of our ES&H program. Details of ES&H work performed for the Office of Environmental Restoration and Waste Management (EM) are given in chapter 7.

This funding by EM is for the remediation of hazards at waste sites and the development of processes to handle hazardous wastes. Projects are managed and updated annually by EM. Non-EM activities are then funded directly by other programs or through Sandia's indirect budget.

EM-sponsored environmental remediation of waste sites is expected to continue during cleanup of critical sites and to then decline. As processes are developed to handle hazardous wastes, direct EM support is expected to decline while the indirect budget sustains funding to improve the developed processes. Waste handling costs will be charged to the generating organizations.



## Core ES&H Programs

The core programs supported by Sandia's indirect budget are the base for all laboratory ES&H efforts. This base includes most activities in policy development and implementation, safety and health, and specific activities in environmental operations. In addition, this budget supports independent assessment and core training.

## Program Management

Responsible translation and integration of new laws, regulations, orders, directives, and requests into effective operations is increasing in complexity due to changes in

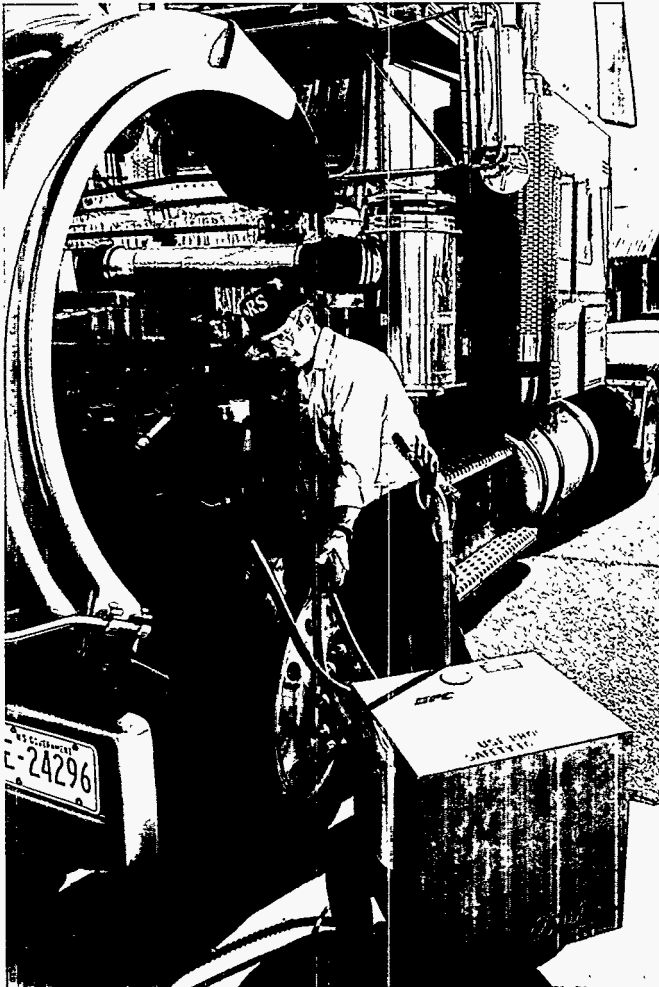

Waste minimization activities have alleviated waste and saved money. Fred Raether demonstrates a blender that filters crankcase oil and mixes it with diesel fuel for use as heating fuel.

requirements. New requirements are integrated into operations through Sandia organizational ES&H coordinators as a part of the Line Implementation Working Group.

An effective prioritization system is a high priority as requirements continue to increase and budgets decrease. An integrated services management system (ISMS) is being developed that will be piloted by the Laboratory Services Division during FY 1995 and 1996 and will serve as a model for Sandia. The ISMS will integrate policies, strategic planning, issues management, operational planning, resource management, commitment management and accountability, and process and project planning. The goal is to provide the tools needed to efficiently meet customer requirements. The ISMS is a part of the DOE prioritization project.

The overall tracking and management of occurrences and assessment responses is being reviewed along with other management information systems to define the most cost-effective way for maintaining and interconnecting databases. Better ways must be found to interface with the data systems used by various DOE and other regulatory agencies.

Risk management, including safety assessment and analysis reporting, is a growing effort. Programs for managing risks and hazards are being implemented in compliance with DOE orders. Hazard assessments of all sites are being completed to upgrade emergency preparedness.

## Assessments

ES&H assessments of Sandia by external organizations are coordinated through the ES&H Assessments Management Department. The department interacts with assessors to assure that their logistical needs are met, works with all parties to develop appropriate responses to assessment findings, tracks the status of all responses, submits closure documents, and is the official records manager for assessment documents. Emphasis is now being placed on assuring that the multiple assessments are appropriately documented and tracked and that records storage requirements are met. Quality review processes are being developed to assure that responses meet the intent of findings.

The ES&H Assessments Management Department provides independent internal assessments of Sandia operations and reports directly to the Vice President of Laboratory Services. A major emphasis of the department is to develop effective root cause analysis, lessons learned, and performance indicator and management self-assessment processes to reduce the need for assessments.

## Training

The ES&H Training Department in Sandia's Human

Resources Center is responsible for developing and maintaining administrative training systems and processes for Sandia. Department staff work with ES&H professionals and line personnel to design, develop, and present laboratory-wide and organization-specific courses for the Sandia work force. Costs to deliver training are recovered through the ES&H Training Service Center. Additionally, the ES&H Training Department is responsible for maintaining training records and managing the reporting function. Emphasis on training continues to increase and new methods and technologies are being introduced.

## Waste Management

Waste management projects implement steps to safely and efficiently manage Sandia's hazardous, radioactive,

and mixed wastes. This effort includes projects in minimization, treatment, storage, disposal, and project management.

Sandia/New Mexico holds a 1992 operating permit for hazardous waste management. All radioactive waste is either stored on site or sent to disposal facilities authorized by DOE. Hazardous waste is temporarily stored in the hazardous waste management facility, then transported off site for recycling, treatment, or disposal at commercial facilities with Environmental Protection Agency (EPA) permits. Mixed wastes are held on site in storage areas that were included in the interim status permit application for mixed waste units submitted to the New Mexico Environmental Department in 1990. Also included in the permit application was a facility (not yet operational) that will be used for repackaging and storage of low-level radioactive waste and mixed waste.

Sandia/California has a Resource Conservation and



Instructor Ramon Maldonado watches as Sandian Mary Gilliland extinguishes a flammable liquid fire.

Recovery Act permit for operation of its hazardous waste management facility. Hazardous wastes at Sandia/California are disposed at various permitted commercial disposal facilities. Compatible waste streams are consolidated at Sandia's hazardous waste storage facility to decrease costs. These consolidated streams are analyzed before disposal in accordance with the hazardous waste facility permit that was approved by the federal EPA and the California EPA. Low-level waste is disposed at the Nevada Test Site (NTS) in compliance with DOE orders, EPA and State of California requirements, and NTS criteria. "Scintillation cocktails" (small vials of low-level radioactive liquids) from the Tritium Research Laboratory are transported to a permitted commercial facility for incineration. Other low-level mixed waste streams will be stored at Sandia/California until off-site disposal options are developed.

Hazardous materials generated at the Tonopah Test Range are shipped to commercial facilities for disposal within ninety days of generation. The NTS has stopped accepting radioactive wastes, and several drums of legacy radioactive materials are stored on site, pending determination of a repository. No radioactive wastes are currently generated by operations at Tonopah. No mixed wastes have been or are generated at the site.

The Kauai Test Facility generates small quantities of hazardous wastes, which are handled through the Navy Pacific Missile Range waste management program. No radioactive or mixed wastes have been or are being generated at this facility.

In addition to the need for adequate funding to perform waste management operations, there is an acute need for approved treatment and disposal facilities for hazardous, radioactive, and mixed wastes. Such facilities are particularly needed for mixed wastes. The lack of treatment and disposal facilities for mixed wastes is a significant problem for the entire DOE complex and results in the storage of mixed wastes beyond the legally allowable time.

## Safety and Health

The occupational safety program at Sandia makes the safety of personnel its first priority. The bases of our technical support are the programs and procedures developed to reflect DOE orders, regulations of the Occupational Safety and Health Act (OSHA), and other safety laws and best practices.

We are working to institutionalize safety training and procedures. Risk management, including support for safety assessments and safety analysis reports, is a large effort that will continue to grow. Sandia is completing a hazard assessment for all sites so emergency plans and procedures can be upgraded. We are continuing our efforts to improve programs in fire protection and emergency preparedness, and also in electrical, pressure, reactor, hoisting and rigging, and traffic safety.

Sandia's security organization established a committee

to review costs of operating vehicles. A list of accidents involving security vehicles was compiled and the causes analyzed. As a result, pickup trucks are being replaced by Jeep Cherokees, which are better suited to security work. Shift lieutenants are now required to inspect 50 percent of assigned vehicles each shift for damage. A vehicle safe use campaign is under way, a defensive driving class is being established, and a safe driving class is mandatory for new hires

We are giving increased attention to upgrading safety procedures and implementing safety programs at remote sites such as the Tonopah Test Range. In addition, an acute need exists to modify older facilities and obtain proper equipment for safe operations at such sites.

We have initiated a long-term ergonomics effort that will meet the requirements of DOE orders and upcoming OSHA regulations. This program has the potential to interface with other preventive medicine programs (such as total life concept and employee assistance) and to provide a vehicle for addressing ES&H concerns.

The objective of the health management program is to maintain the physical and psychological health of Sandia's work force through timely evaluation, diagnosis, and management linked to analysis of the work site and occupational environment. This objective requires that we interpret and apply health codes, standards, and regulations promulgated by several federal and state agencies and national standards organizations. Core activities provide protection from chemical and physical hazards in the workplace and furnish oversight, monitoring, contamination control, and other radiation protection assistance for workers. Medical intervention programs and educational and fitness programs promote safe and healthful worker lifestyles.

A radiological control manager leads a radiation protection program that enables Sandia to comply with the DOE Radiological Control Manual and applicable federal regulations. Planning for compliance with these directives and regulations began in 1992 and continues as requirements change.

Safety and health compliance activities identify remedial actions necessary to move Sandia toward compliance with applicable OSHA regulations and DOE orders. Specific remedial activities address audit findings and concerns in accordance with a completion schedule approved by DOE or other audit groups.

## Environmental Protection

Environmental protection activities provide Sandia organizations the support necessary for compliance with the Clean Water Act, the Clean Air Act, DOE Order 5400.1, and various other requirements and permits issued by local, state, and federal agencies. Activities include management of sanitary sewer waste, storm water discharges, spills, air quality, and environmental compliance.



## 12 • Security Management

### Program Overview

The Safeguards and Security (SAS) Program is responsible for protection of the Department of Energy's (DOE's) assets at all Sandia sites in accordance with the requirements of our primary customer (DOE), our Sandia customers, and other stakeholders. The major activities that make up the SAS program include

- program planning and management,
- protection program operations,
- operations security,
- information security,
- personnel security,
- facility surveys and approvals,
- material control and accountability,
- nuclear material management, and
- special programs.

The missions of both DOE and Sandia have changed in accordance with the fluctuating world situation. DOE's requirements are changing and Sandia's customer mix is shifting. In response the security infrastructure is being adjusted, placing an added burden on Sandia's limited resources and requiring development of new cost-effective solutions to SAS needs.

### Protection Philosophy

The overall SAS program philosophy is to design strategies to protect classified material and government property from unauthorized access, theft, diversion, sabotage, espionage, or other hostile acts that may cause risks to national security or the health and safety of DOE and contractor employees, the public, or the environment.

Performance-based levels of protection and other safeguards must be commensurate with DOE's design threat guidance and other programmatic constraints. In the past we worked toward total compliance. In the future we will design strategies that offer equivalent and appropriate protection.

The Sandia SAS Program is based on risk management. In this context, risk management means that complexity of analysis, thoroughness of documentation, and levels of effort are commensurate with consequences of failure (risk), value of assets, cost of implementation, and other factors. The higher the risk, the greater the protection should be. This risk management approach is used to eliminate unnecessary features or activities that add to costs of implementation but don't add value to the protection system.

## Evolving Site Security Needs

Protection requirements have been modified due to decreasing weapons research and development coupled with an increase in partnerships with private industry to improve economic competitiveness through technology transfer. Modifications include the introduction of the L

clearance, the reduction in secret matter accountability requirements, and the restructuring of security areas. We anticipate more changes in DOE requirements over the next few years.

Sandia's changing customer mix requires increased protection of proprietary information and easing of site access for Sandia partners. The new customer mix requires SAS programs to be rapidly adapted to provide protection with greater flexibility. This new customer set also encourages the development of administrative controls placing more responsibility on all Sandians. Employees must become proactive in questioning badged individuals about information access, be more responsible for asset protection, and participate in security self-assessments.

Major initiatives and integrated capabilities play a large role in the modification of protection systems. As a result, Sandia line organizations and customers now participate in making decisions about protection systems established for their programs and facilities.



Two members of Sandia's Special Response Team (SRT) use their skills to evaluate intrusion sensors. The SRT is charged with protecting personnel and facilities in the event of a crisis. Standardized training enables them to interact with any protective force in the DOE complex.

---

## The Changing Face of Security

The new mission of DOE and Sandia requires changes in the security infrastructure. In the future our sites will be reconfigured to enhance customer access. Many of our fenced security areas will be opened. Visitor access will be controlled by line personnel rather than armed security police officers at

the gates. We will create more compartmented security areas within facilities accessible to our uncleared customers. Safeguards and Security will partner with line organizations, their customers, and DOE to implement an effective risk management approach documented in customized security plans.

This planning and facility integration will lead to customized, more cost-effective, efficient protection systems.

*Appendix*

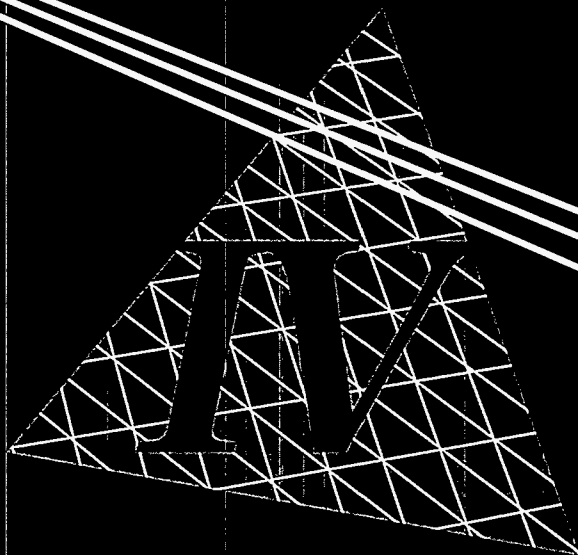



## 13 • Resource Projections

This section presents a five-year budget projection for Sandia National Laboratories. Budget authority dollars are in millions; personnel are in annual average full-time equivalents (FTEs).

Amounts for operating, capital equipment, and general plant project (GPP) funds in fiscal year (FY) 1993 through FY 1996 are expressed in the dollars of their respective years. For FY 1997 and beyond, operating, capital equipment, and GPP estimates are in FY 1996 dollars. Estimates for major construction projects are expressed in dollars of the year of commencement of each project.

Amounts shown for FY 1994 are the final budget authority. Figures shown for fiscal years 1995 and 1996 are based on our FY 1996 Annual Budget Submission and

conform to targets provided by DOE.

Our strategy during the uncertain times ahead will be a conservative one. We will conserve resources by encouraging outsourcing and entering into cost-sharing partnership arrangements with other public and private entities. We anticipate a continued substantial level of cooperative research and development agreements (CRADAs) with industry; however, CRADA efforts cannot be anticipated and budgeted in the same manner as other work. We will manage the flow of work into the laboratory to maintain a reasonable backlog that can ameliorate the impact of a sudden shift in funding levels. Staffing will be controlled within a range appropriate for anticipated conditions.



---

# Sandia National Laboratories

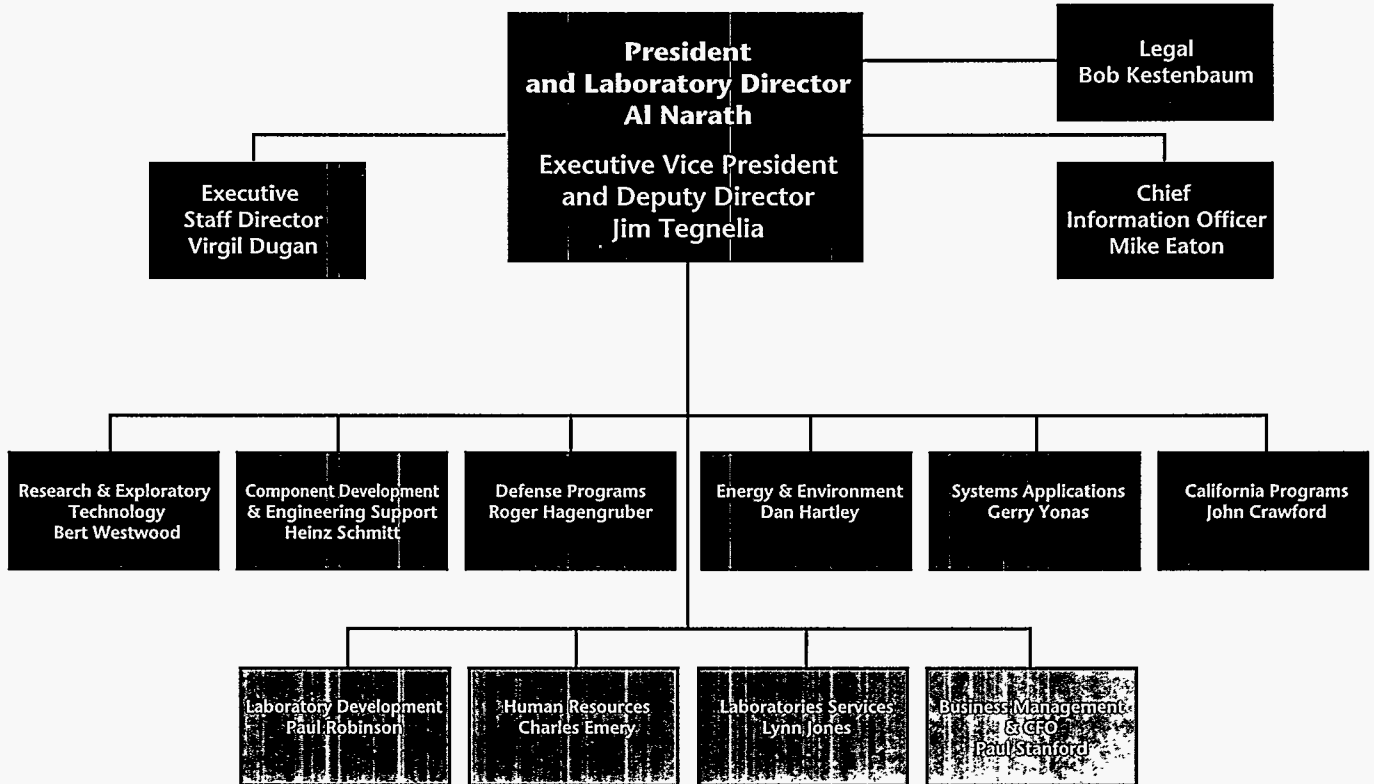

**LABORATORIES FUNDING SUMMARY**  
 (Fiscal Year Budget Authority in Millions)

	<u>FY93</u>	<u>FY94</u>	<u>FY95</u>	<u>FY96</u>	<u>FY97</u>	<u>FY98</u>	<u>FY99</u>	<u>FY00</u>
DOE Effort	932.8	997.5	966.2	1001.3	1017.5	1022.5	1022.5	1022.5
Work for Others	378.2	295.5	295.5	300.0	300.0	300.0	300.0	300.0
<b>TOTAL OPERATING</b>	<b>1311.0</b>	<b>1293.0</b>	<b>1261.7</b>	<b>1301.3</b>	<b>1317.5</b>	<b>1322.5</b>	<b>1322.5</b>	<b>1322.5</b>
Capital Equipment	49.4	36.6	72.8	71.6	74.2	76.4	82.1	82.1
General Plant Projects	9.9	-2.7	4.8	4.8	6.6	8.6	8.6	8.6
Major Construction	40.7	33.8	84.9	40.1	5.1			
<b>TOTAL FUNDING</b>	<b>1411.0</b>	<b>1360.7</b>	<b>1424.2</b>	<b>1417.8</b>	<b>1403.4</b>	<b>1407.5</b>	<b>1413.2</b>	<b>1413.2</b>
Proposed Construction				1.5	28.5	66.1	105.9	106.7

## Laboratory Funding Profile Summary

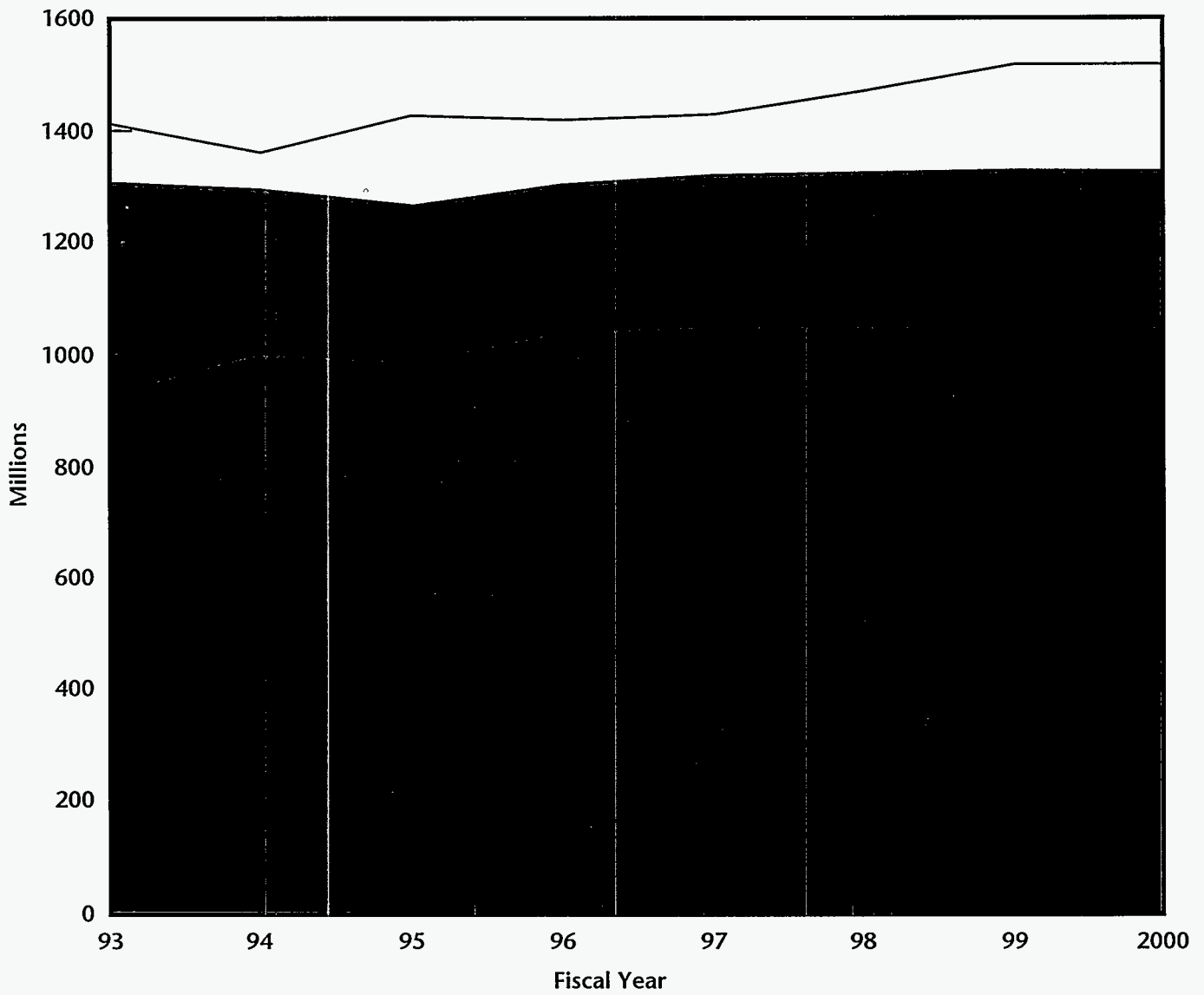

■ DOE Effort

■ Work for Others

□ Plant and Equipment

## Laboratory Program Funding for DOE

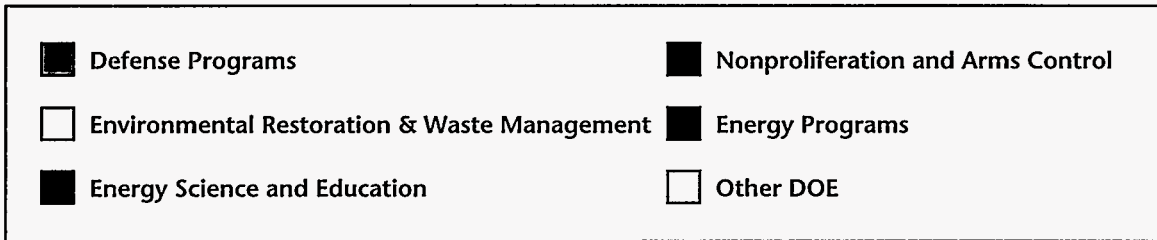
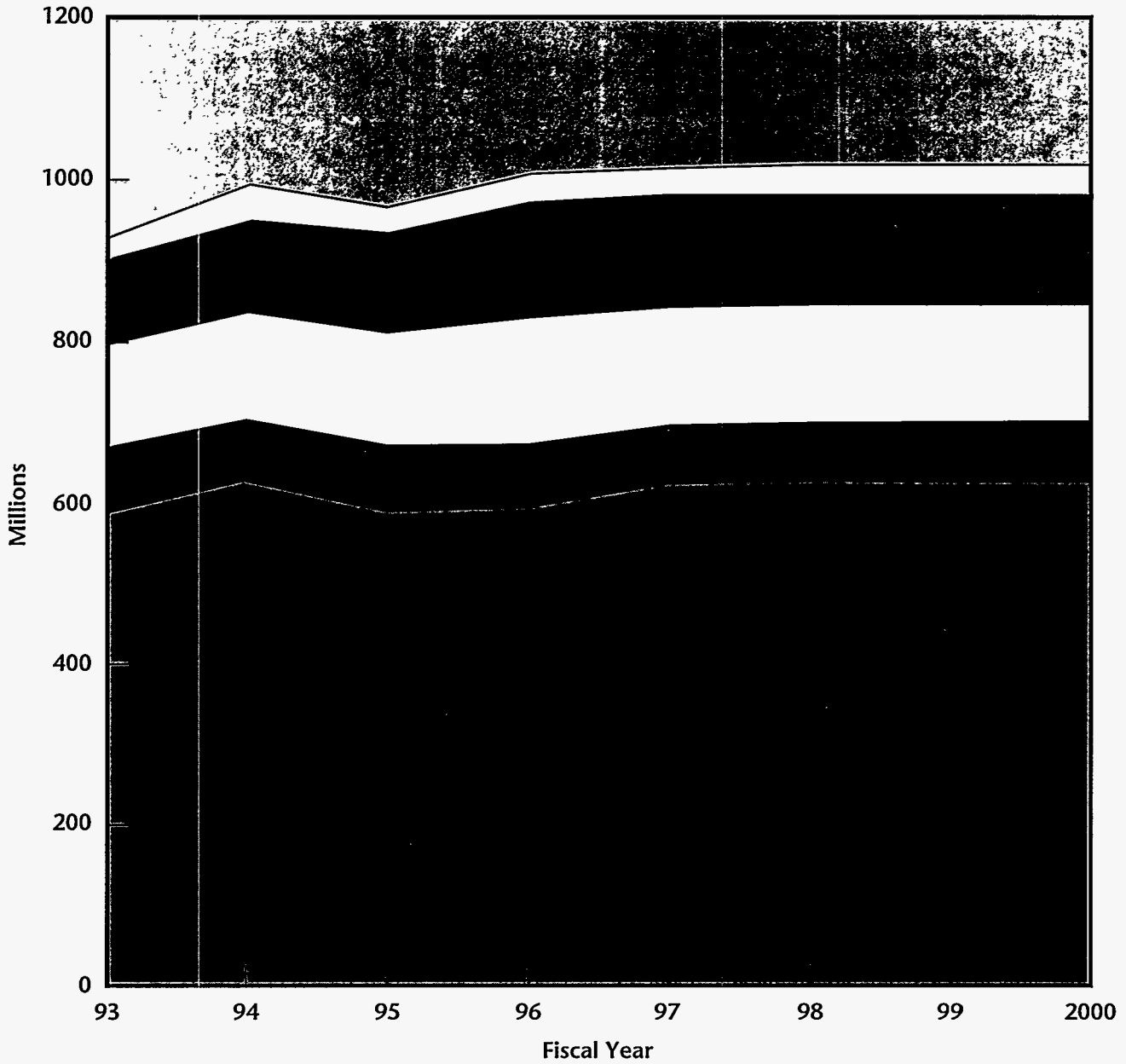

PERSONNEL SUMMARY BY MAJOR SPONSOR  
(FTEs)

	<u>FY93</u>	<u>FY94</u>	<u>FY95</u>	<u>FY96</u>	<u>FY97</u>	<u>FY98</u>	<u>FY99</u>	<u>FY00</u>
<b>DOE PROGRAMS</b>								
Weapons and Waste Cleanup Programs								
Defense Programs	2204	2040	1926	1880	1875	1875	1875	1875
Intelligence and National Security	302	357	375	365	365	365	365	365
Environmental Restoration and Waste Management	298	348	374	400	390	365	365	365
Energy Programs								
Energy Efficiency and Renewable Energy	140	123	136	139	139	139	139	139
Civilian Radioactive Waste Management	52	51	89	89	89	89	89	89
Fossil Energy	39	38	38	28	33	33	33	33
Nuclear Energy	15	12	11	11	11	11	11	11
Science and Technology Programs								
Energy Research	105	99	99	102	102	102	102	102
Science Education and Technical Information	1	1	4	5	5	5	5	5
Other DOE Work	110	140	140	140	140	140	140	140
<b>Total DOE Programs</b>	<b>3266</b>	<b>3209</b>	<b>3192</b>	<b>3159</b>	<b>3149</b>	<b>3124</b>	<b>3124</b>	<b>3124</b>
<b>PROGRAMS OTHER THAN FOR DOE</b>								
Department of Defense	751	644	630	630	630	630	630	630
Nuclear Regulatory Commission	54	55	48	48	48	48	48	48
Department of Transportation	18	16	25	25	25	25	25	25
National Aeronautics and Space Administration	14	15	15	15	15	15	15	15
Department of State	1	1	1	1	1	1	1	1
Environmental Protection Agency	1	2	5	5	5	5	5	5
Other Federal Agencies	69	89	90	90	90	90	90	90
All Others	54	70	77	77	77	77	77	77
<b>Total Work for Others</b>	<b>962</b>	<b>892</b>	<b>891</b>	<b>891</b>	<b>891</b>	<b>891</b>	<b>891</b>	<b>891</b>
<b>TOTAL DIRECT PROGRAMS</b>	<b>4228</b>	<b>4101</b>	<b>4083</b>	<b>4050</b>	<b>4040</b>	<b>4015</b>	<b>4015</b>	<b>4015</b>
Laboratory-Directed R&D	205	220	220	220	220	220	220	220
Direct Support	1877	1741	1740	1740	1740	1740	1740	1740
Indirect	2187	2426	2425	2425	2425	2425	2425	2425
<b>TOTAL LABORATORIES</b>	<b>8497</b>	<b>8488</b>	<b>8468</b>	<b>8435</b>	<b>8425</b>	<b>8400</b>	<b>8400</b>	<b>8400</b>

**FUNDING BY ASSISTANT SECRETARIAL OFFICE**  
(Fiscal Year Budget Authority in Millions)

	<u>FY93</u>	<u>FY94</u>	<u>FY95</u>	<u>FY96</u>	<u>FY97</u>	<u>FY98</u>	<u>FY99</u>	<u>FY00</u>
<b>Weapons and Waste Cleanup Programs</b>								
Total, Assistant Secretary For Defense Programs								
Operating	591.0	614.1	566.7	573.8	595.3	600.3	600.3	600.3
Capital Equipment	39.3	26.6	59.2	57.0	59.6	61.8	67.5	67.5
General Plant Projects	8.6	-2.3	4.0	4.0	6.0	8.0	8.0	8.0
Major Construction	30.7	25.3	75.5	30.6	5.1			
Total Cost	669.6	663.7	705.4	665.4	666.0	670.1	675.8	675.8
<b>Total, Office of Nonproliferation and National Security</b>								
Operating	79.8	90.6	105.5	105.5	107.4	107.4	107.4	107.4
Capital Equipment	3.2	3.7	4.0	4.0	4.0	4.0	4.0	4.0
Major Construction	10.0	8.5						
Total Cost	93.0	102.8	109.5	109.5	111.4	111.4	111.4	111.4
<b>Total, Office of Environmental Restoration and Waste Management</b>								
Operating	126.6	134.4	136.3	153.5	144.4	144.4	144.4	144.4
Capital Equipment	3.3	2.6	4.0	4.0	4.0	4.0	4.0	4.0
General Plant Projects	1.1	-0.6	0.2	0.2				
Total Cost	131.0	136.4	140.5	157.7	148.4	148.4	148.4	148.4
<b>Energy Programs</b>								
Total, Assistant Secretary for Energy Efficiency and Renewable Energy								
Operating	46.0	46.8	55.2	58.0	58.0	58.0	58.0	58.0
Capital Equipment	1.0	0.9	1.8	2.1	2.1	2.1	2.1	2.1
Total Cost	47.0	47.7	57.0	60.1	60.1	60.1	60.1	60.1
Total, Civilian Radioactive Waste Management								
Operating	15.6	15.3	17.6	19.0	19.0	19.0	19.0	19.0
Capital Equipment		0.1	0.3	0.4	0.4	0.4	0.4	0.4
Total Cost	15.6	15.4	17.9	19.4	19.4	19.4	19.4	19.4
Total, Assistant Secretary for Fossil Energy								
Operating	8.8	11.8	9.9	10.5	11.8	11.8	11.8	11.8
Capital Equipment			0.5	0.5	0.5	0.5	0.5	0.5
Total Cost	8.8	11.8	10.4	11.0	12.3	12.3	12.3	12.3
Total, Office of Nuclear Energy								
Operating	2.0	4.8	2.1	2.1	2.1	2.1	2.1	2.1

▲

**FUNDING BY ASSISTANT SECRETARIAL OFFICE (CONTINUED)**  
(Fiscal Year Budget Authority in Millions)

	<u>FY93</u>	<u>FY94</u>	<u>FY95</u>	<u>FY96</u>	<u>FY97</u>	<u>FY98</u>	<u>FY99</u>	<u>FY00</u>
<b>Science and Technology Programs</b>								
Total, Office of Energy Research								
Operating	28.7	28.6	32.6	36.3	36.3	36.3	36.3	36.3
Capital Equipment	2.6	2.7	2.7	3.4	3.4	3.4	3.4	3.4
General Plant Projects	0.2	0.2	0.6	0.6	0.6	0.6	0.6	0.6
Major Construction			9.4	9.5				
Total Cost	31.5	31.5	45.3	49.8	40.3	40.3	40.3	40.3
Total, Office of Science Education and Technical Information								
Operating	3.0	2.2	2.1	2.0	3.1	3.1	3.1	3.1
Capital Equipment			0.3	0.2	0.2	0.2	0.2	0.2
Total Cost	3.0	2.2	2.4	2.2	3.3	3.3	3.3	3.3
<b>Work for Other DOE Locations, Contractors, and Offices</b>								
Total, Office of Economic Impact and Diversity								
Operating	0.5		0.7	0.6	0.1	0.1	0.1	0.1
Total, All Other								
Operating	30.8	48.9	37.5	40.0	40.0	40.0	40.0	40.0
<hr/>								
<b>Total DOE Programs</b>								
Operating	932.8	997.5	966.2	1001.3	1017.5	1022.5	1022.5	1022.5
Capital Equipment	49.4	36.6	72.8	71.6	74.2	76.4	82.1	82.1
General Plant Projects	9.9	-2.7	4.8	4.8	6.6	8.6	8.6	8.6
Major Construction	40.7	33.8	84.9	40.1	5.1			
Total Cost	1032.8	1065.2	1128.7	1117.8	1103.4	1107.5	1113.2	1113.2
Proposed Construction				1.5	28.5	66.1	105.9	106.7

**ASSISTANT SECRETARY FOR DEFENSE PROGRAMS**  
**RESOURCES BY MAJOR PROGRAM**  
 (Fiscal Year Budget Authority in Millions; Personnel in FTEs)

	<u>FY93</u>	<u>FY94</u>	<u>FY95</u>	<u>FY96</u>	<u>FY97</u>	<u>FY98</u>	<u>FY99</u>	<u>FY00</u>
<b>GB0103 Research and Development</b>								
Operating	339.0	286.8	258.0	264.1	268.5	268.5	268.5	268.5
Capital Equipment	34.9	21.4	30.4	33.4	32.4	34.4	37.6	37.6
General Plant Projects	6.8	-2.2	3.0	3.0	5.0	7.0	7.0	7.0
Major Construction	19.4	22.6	32.0	12.2	5.1			
Total Cost	400.1	328.6	323.4	312.7	311.0	309.9	313.1	313.1
Direct Personnel	1274	997	945	940	940	940	940	940
<b>GB0104 Testing</b>								
Operating	37.2	31.7	40.6	40.6	35.0	35.0	35.0	35.0
Capital Equipment	5.4	2.5	2.5	2.0	2.5	2.5	2.5	2.5
Total Cost	42.6	34.2	43.1	42.6	37.5	37.5	37.5	37.5
Direct Personnel	153	129	140	136	120	120	120	120
<b>GB0106 Technology Transfer Initiative</b>								
Operating	50.2	80.1	75.3	75.3	90.0	90.0	90.0	90.0
Capital Equipment		0.6	1.0	1.0	1.0	1.0	1.0	1.0
Total Cost	50.2	80.7	76.3	76.3	91.0	91.0	91.0	91.0
Direct Personnel	108	233	275	286	300	300	300	300
<b>GB0107 Newly Independent States Partnerships</b>								
Operating		16.6	16.6	16.6	16.6	16.6	16.6	16.6
Direct Personnel			5	5	5	5	5	5
<b>GB02 Inertial Confinement Fusion</b>								
Operating	30.0	26.3	28.6	30.6	30.6	30.6	30.6	30.6
Capital Equipment	1.6	0.9	0.9	0.9	0.9	0.9	0.9	0.9
Total Cost	31.6	27.2	29.5	31.5	31.5	31.5	31.5	31.5
Direct Personnel	74	63	64	68	68	68	68	68
<b>GB03 Stockpile Support</b>								
Operating	122.0	142.3	141.0	141.0	150.0	155.0	155.0	155.0
Capital Equipment	-2.9	1.0	24.2	19.5	22.6	22.8	25.3	25.3
General Plant Projects	1.8	-0.1	1.0	1.0	1.0	1.0	1.0	1.0
Major Construction	3.3	0.6						
Total Cost	124.2	143.8	166.2	161.5	173.6	178.8	181.3	181.3
Direct Personnel	562	539	475	428	430	430	430	430



**ASSISTANT SECRETARY FOR DEFENSE PROGRAMS (CONTINUED)**  
**RESOURCES BY MAJOR PROGRAM**  
 (Fiscal Year Budget Authority in Millions; Personnel in FTEs)

	<u>FY93</u>	<u>FY94</u>	<u>FY95</u>	<u>FY96</u>	<u>FY97</u>	<u>FY98</u>	<u>FY99</u>	<u>FY00</u>
GB05 Program Direction								
Operating	11.2	6.6	4.6	4.6	4.6	4.6	4.6	4.6
Capital Equipment		0.2	0.2	0.2	0.2	0.2	0.2	0.2
Total Cost	11.2	6.8	4.8	4.8	4.8	4.8	4.8	4.8
Direct Personnel	30	14	12	12	12	12	12	12
GB06 Reconfiguration								
Operating		21.6	1.0					
Capital Equipment	0.3							
Major Construction	8.0	2.1	43.5	18.4				
Total Cost	8.3	23.7	44.5	18.4				
Direct Personnel		61	5					
GB Weapon Activities								
Operating	589.6	612.0	565.7	572.8	595.3	600.3	600.3	600.3
Capital Equipment	39.3	26.6	59.2	57.0	59.6	61.8	67.5	67.5
General Plant Projects	8.6	-2.3	4.0	4.0	6.0	8.0	8.0	8.0
Major Construction	30.7	25.3	75.5	30.6	5.1			
Total Cost	668.2	661.6	704.4	664.4	666.0	670.1	675.8	675.8
Direct Personnel	2201	2036	1921	1875	1875	1875	1875	1875
GE Materials Production—Reactor Operations								
Operating	1.4	2.1	1.0	1.0				
Direct Personnel	3	4	5	5				
<b>Total, Assistant Secretary for Defense Programs</b>								
Operating	591.0	614.1	566.7	573.8	595.3	600.3	600.3	600.3
Capital Equipment	39.3	26.6	59.2	57.0	59.6	61.8	67.5	67.5
General Plant Projects	8.6	-2.3	4.0	4.0	6.0	8.0	8.0	8.0
Major Construction	30.7	25.3	75.5	30.6	5.1			
Total Cost	669.6	663.7	705.4	665.4	666.0	670.1	675.8	675.8
Direct Personnel	2204	2040	1926	1880	1875	1875	1875	1875
Proposed Construction				1.5	25.5	57.5	83.9	87.7

**OFFICE OF NONPROLIFERATION AND NATIONAL SECURITY**  
**RESOURCES BY MAJOR PROGRAM**  
 (Fiscal Year Budget Authority in Millions; Personnel in FTEs)

	<u>FY93</u>	<u>FY94</u>	<u>FY95</u>	<u>FY96</u>	<u>FY97</u>	<u>FY98</u>	<u>FY99</u>	<u>FY00</u>
GC Verification and Control Technology; and GJ Export Control, Nonproliferation, and International Programs								
Operating	67.6	77.9	94.1	94.1	95.0	95.0	95.0	95.0
Capital Equipment	2.3	2.6	2.8	2.8	2.8	2.8	2.8	2.8
Major Construction	10.0	8.5						
Total Cost	79.9	89.0	96.9	96.9	97.8	97.8	97.8	97.8
Direct Personnel	246	297	325	316	315	315	315	315
GD Nuclear Safeguards & Security								
Operating	9.1	9.9	8.0	8.0	9.0	9.0	9.0	9.0
Capital Equipment	0.9	0.9	1.0	1.0	1.0	1.0	1.0	1.0
Total Cost	10.0	10.8	9.0	9.0	10.0	10.0	10.0	10.0
Direct Personnel	44	45	40	39	40	40	40	40
NT Intelligence								
Operating	3.1	2.8	3.4	3.4	3.4	3.4	3.4	3.4
Capital Equipment		0.2	0.2	0.2	0.2	0.2	0.2	0.2
Total Cost	3.1	3.0	3.6	3.6	3.6	3.6	3.6	3.6
Direct Personnel	12	15	10	10	10	10	10	10
<b>Total, Office of Nonproliferation and National Security</b>								
Operating	79.8	90.6	105.5	105.5	107.4	107.4	107.4	107.4
Capital Equipment	3.2	3.7	4.0	4.0	4.0	4.0	4.0	4.0
Major Construction	10.0	8.5						
Total Cost	93.0	102.8	109.5	109.5	111.4	111.4	111.4	111.4
Direct Personnel	302	357	375	365	365	365	365	365

**OFFICE OF ENVIRONMENTAL RESTORATION AND WASTE MANAGEMENT**  
**RESOURCES BY MAJOR PROGRAM**  
 (Fiscal Year Budget Authority in Millions; Personnel in FTEs)

	<u>FY93</u>	<u>FY94</u>	<u>FY95</u>	<u>FY96</u>	<u>FY97</u>	<u>FY98</u>	<u>FY99</u>	<u>FY00</u>
EW Environmental Restoration and Waste Management								
Operating	126.6	134.4	136.3	153.5	144.4	144.4	144.4	144.4
Capital Equipment	3.3	2.6	4.0	4.0	4.0	4.0	4.0	4.0
General Plant Projects	1.1	-0.6	0.2	0.2				
Total Cost	131.0	136.4	140.5	157.7	148.4	148.4	148.4	148.4
Direct Personnel	298	348	374	400	390	365	365	365
Proposed Construction					3.0	7.0	10.0	10.0

**ASSISTANT SECRETARY FOR ENERGY EFFICIENCY AND RENEWABLE ENERGY**  
**RESOURCES BY MAJOR PROGRAM**  
 (Fiscal Year Budget Authority in Millions; Personnel in FTEs)

	<u>FY93</u>	<u>FY94</u>	<u>FY95</u>	<u>FY96</u>	<u>FY97</u>	<u>FY98</u>	<u>FY99</u>	<u>FY00</u>
<b>AK Electric Energy Systems</b>								
Operating	1.5	1.6	2.5	2.5	2.5	2.5	2.5	2.5
Capital Equipment			0.1	0.2	0.2	0.2	0.2	0.2
Total Cost	1.5	1.6	2.6	2.7	2.7	2.7	2.7	2.7
Direct Personnel	5	6	5	5	5	5	5	5
<b>AL Energy Storage Systems</b>								
Operating	3.7	5.1	5.1	5.4	5.4	5.4	5.4	5.4
Capital Equipment	0.3	0.3	0.3	0.3	0.3	0.3	0.3	0.3
Total Cost	4.0	5.4	5.4	5.7	5.7	5.7	5.7	5.7
Direct Personnel	6	5	6	6	6	6	6	6
<b>AM Geothermal Systems</b>								
Operating	7.1	4.2	7.5	7.4	7.3	7.3	7.3	7.3
Capital Equipment	0.3	0.2	0.2	0.2	0.2	0.2	0.2	0.2
Total Cost	7.4	4.4	7.7	7.6	7.5	7.5	7.5	7.5
Direct Personnel	18	13	16	16	16	16	16	16
<b>AR Hydrogen Research</b>								
Operating		2.1	0.5	0.5	0.6	0.6	0.6	0.6
Direct Personnel		5	2	2	2	2	2	2
<b>EB Solar Energy</b>								
Operating	26.5	29.1	33.3	35.0	35.0	35.0	35.0	35.0
Capital Equipment	0.2	0.3	0.3	0.5	0.5	0.5	0.5	0.5
Total Cost	26.7	29.4	33.6	35.5	35.5	35.5	35.5	35.5
Direct Personnel	81	76	81	83	83	83	83	83
<b>ED Industrial Sector</b>								
Operating	4.8	3.1	4.6	4.9	4.9	4.9	4.9	4.9
Capital Equipment	0.2	0.1	0.6	0.6	0.6	0.6	0.6	0.6
Total Cost	5.0	3.2	5.2	5.5	5.5	5.5	5.5	5.5
Direct Personnel	25	13	21	21	21	21	21	21
<b>EE Transportation Sector</b>								
Operating	2.4	1.5	1.7	2.3	2.3	2.3	2.3	2.3
Capital Equipment			0.3	0.3	0.3	0.3	0.3	0.3
Total Cost	2.4	1.5	2.0	2.6	2.6	2.6	2.6	2.6
Direct Personnel	5	5	5	6	6	6	6	6

**ASSISTANT SECRETARY FOR ENERGY EFFICIENCY AND RENEWABLE ENERGY (CONTINUED)**  
**RESOURCES BY MAJOR PROGRAM**  
 (Fiscal Year Budget Authority in Millions; Personnel in FTEs)

	<u>FY93</u>	<u>FY94</u>	<u>FY95</u>	<u>FY96</u>	<u>FY97</u>	<u>FY98</u>	<u>FY99</u>	<u>FY00</u>
EC Buildings Sector; and EF State and Local Programs Operating		0.1						
<hr/>								
Total, Assistant Secretary for Energy Efficiency and Renewable Energy								
Operating	46.0	46.8	55.2	58.0	58.0	58.0	58.0	58.0
Capital Equipment	1.0	0.9	1.8	2.1	2.1	2.1	2.1	2.1
Total Cost	47.0	47.7	57.0	60.1	60.1	60.1	60.1	60.1
Direct Personnel	140	123	136	139	139	139	139	139

**OFFICE OF CIVILIAN RADIOACTIVE WASTE MANAGEMENT**  
**RESOURCES BY MAJOR PROGRAM**  
 (Fiscal Year Budget Authority in Millions; Personnel in FTEs)

	<u>FY93</u>	<u>FY94</u>	<u>FY95</u>	<u>FY96</u>	<u>FY97</u>	<u>FY98</u>	<u>FY99</u>	<u>FY00</u>
DB Nuclear Waste Fund								
Operating	15.6	15.3	17.6	19.0	19.0	19.0	19.0	19.0
Capital Equipment		0.1	0.3	0.4	0.4	0.4	0.4	0.4
Total Cost	15.6	15.4	17.9	19.4	19.4	19.4	19.4	19.4
Direct Personnel	52	51	89	89	89	89	89	89

**ASSISTANT SECRETARY FOR FOSSIL ENERGY**  
**RESOURCES BY MAJOR PROGRAM**  
 (Fiscal Year Budget Authority in Millions; Personnel in FTEs)

	<u>FY93</u>	<u>FY94</u>	<u>FY95</u>	<u>FY96</u>	<u>FY97</u>	<u>FY98</u>	<u>FY99</u>	<u>FY00</u>
AA Coal								
Operating	3.5	3.7	3.0	3.4	4.7	4.7	4.7	4.7
Capital Equipment			0.5	0.5	0.5	0.5	0.5	0.5
Total Cost	3.5	3.7	3.5	3.9	5.2	5.2	5.2	5.2
Direct Personnel	14	12	14	14	19	19	19	19
AB Gas								
Operating	0.6	0.8	1.5	1.5	1.5	1.5	1.5	1.5
Direct Personnel	2	2	2	2	2	2	2	2
AC Petroleum								
Operating	2.6	3.2	3.0	3.0	3.0	3.0	3.0	3.0
Direct Personnel	10	10	10	10	10	10	10	10
SA Strategic Petroleum Reserve								
Operating	2.1	4.1	2.4	2.6	2.6	2.6	2.6	2.6
Direct Personnel	13	14	12	2	2	2	2	2
<b>Total, Assistant Secretary for Fossil Energy</b>								
Operating	8.8	11.8	9.9	10.5	11.8	11.8	11.8	11.8
Capital Equipment			0.5	0.5	0.5	0.5	0.5	0.5
Total Cost	8.8	11.8	10.4	11.0	12.3	12.3	12.3	12.3
Direct Personnel	39	38	38	28	33	33	33	33

**OFFICE OF NUCLEAR ENERGY**  
**RESOURCES BY MAJOR PROGRAM**  
 (Fiscal Year Budget Authority in Millions; Personnel in FTEs)

	<u>FY93</u>	<u>FY94</u>	<u>FY95</u>	<u>FY96</u>	<u>FY97</u>	<u>FY98</u>	<u>FY99</u>	<u>FY00</u>
AF Nuclear Energy Research and Development								
Operating	1.2	4.7	2.1	2.1	2.1	2.1	2.1	2.1
Capital Equipment				0.1	0.1	0.1	0.1	0.1
Total Cost	1.2	4.7	2.1	2.2	2.2	2.2	2.2	2.2
Direct Personnel	11	11	11	11	11	11	11	11
CD Uranium Enrichment								
Operating	0.8	0.1						
Direct Personnel	4	1						
<b>Total, Office of Nuclear Energy</b>								
Operating	2.0	4.8	2.1	2.1	2.1	2.1	2.1	2.1
Capital Equipment				0.1	0.1	0.1	0.1	0.1
Total Cost	2.0	4.8	2.1	2.2	2.2	2.2	2.2	2.2
Direct Personnel	15	12	11	11	11	11	11	11



**OFFICE OF ENERGY RESEARCH**  
**RESOURCES BY MAJOR PROGRAM**  
 (Fiscal Year Budget Authority in Millions; Personnel in FTEs)

	<u>FY93</u>	<u>FY94</u>	<u>FY95</u>	<u>FY96</u>	<u>FY97</u>	<u>FY98</u>	<u>FY99</u>	<u>FY00</u>
AT Magnetic Fusion								
Operating	6.5	6.2	8.0	8.4	8.4	8.4	8.4	8.4
Capital Equipment	0.7	0.5	0.5	0.5	0.5	0.5	0.5	0.5
Total Cost	7.2	6.7	8.5	8.9	8.9	8.9	8.9	8.9
Direct Personnel	25	23	25	25	25	25	25	25
KC Basic Energy Sciences								
Operating	21.8	22.1	23.4	26.5	26.5	26.5	26.5	26.5
Capital Equipment	1.9	2.2	2.2	2.9	2.9	2.9	2.9	2.9
General Plant Projects	0.2	0.2	0.6	0.6	0.6	0.6	0.6	0.6
Major Construction			9.4	9.5				
Total Cost	23.9	24.5	35.6	39.5	30.0	30.0	30.0	30.0
Direct Personnel	76	75	72	75	75	75	75	75
KP Biological and Environmental Research								
Operating	0.4	0.3	1.2	1.4	1.4	1.4	1.4	1.4
Direct Personnel	3	1	2	2	2	2	2	2
KS Superconducting Super Collider								
Operating								
Direct Personnel	1							
Total, Office of Energy Research								
Operating	28.7	28.6	32.6	36.3	36.3	36.3	36.3	36.3
Capital Equipment	2.6	2.7	2.7	3.4	3.4	3.4	3.4	3.4
General Plant Projects	0.2	0.2	0.6	0.6	0.6	0.6	0.6	0.6
Major Construction			9.4	9.5				
Total Cost	31.5	31.5	45.3	49.8	40.3	40.3	40.3	40.3
Direct Personnel	105	99	99	102	102	102	102	102
Proposed Construction						1.6	12.0	9.0

**OFFICE OF SCIENCE EDUCATION AND TECHNICAL INFORMATION**  
**RESOURCES BY MAJOR PROGRAM**  
 (Fiscal Year Budget Authority in Millions; Personnel in FTEs)

	<u>FY93</u>	<u>FY94</u>	<u>FY95</u>	<u>FY96</u>	<u>FY97</u>	<u>FY98</u>	<u>FY99</u>	<u>FY00</u>
KT/KV University and Science Education								
Operating	3.0	2.2	2.1	2.0	3.1	3.1	3.1	3.1
Capital Equipment			0.3	0.2	0.2	0.2	0.2	0.2
Total Cost	3.0	2.2	2.4	2.2	3.3	3.3	3.3	3.3
Direct Personnel	1	1	4	5	5	5	5	5

**WORK FOR OTHER DOE LOCATIONS, CONTRACTORS, AND OFFICES**  
**RESOURCES BY MAJOR PROGRAM**  
 (Fiscal Year Budget Authority in Millions; Personnel in FTEs)

	<u>FY93</u>	<u>FY94</u>	<u>FY95</u>	<u>FY96</u>	<u>FY97</u>	<u>FY98</u>	<u>FY99</u>	<u>FY00</u>
Office of Economic Impact and Diversity								
WA50 Minority Economic Impact Program								
Operating	0.5		0.7	0.6	0.1	0.1	0.1	0.1
Direct Personnel			1	1	1	1	1	1
All Other								
Operating	30.8	48.9	37.5	40.0	40.0	40.0	40.0	40.0
Direct Personnel	110	140	139	139	139	139	139	139
<hr/>								
Total, Other DOE Locations, Contractors, and Offices								
Operating	31.3	48.9	38.2	40.6	40.1	40.1	40.1	40.1
Direct Personnel	110	140	140	140	140	140	140	140

**WORK OTHER THAN FOR DOE**  
**RESOURCES BY MAJOR REIMBURSABLE SPONSOR**  
 (Fiscal Year Budget Authority in Millions; Personnel in FTEs)

	<u>FY93</u>	<u>FY94</u>	<u>FY95</u>	<u>FY96</u>	<u>FY97</u>	<u>FY98</u>	<u>FY99</u>	<u>FY00</u>
Department of Defense								
Operating	295.0	216.7	225.0	225.0	225.0	225.0	225.0	225.0
Direct Personnel	751	644	630	630	630	630	630	630
Nuclear Regulatory Commission								
Operating	14.5	20.2	19.1	20.0	20.0	20.0	20.0	20.0
Direct Personnel	54	55	48	48	48	48	48	48
Department of Transportation								
Operating	5.5	6.8	7.5	8.0	8.0	8.0	8.0	8.0
Direct Personnel	18	16	25	25	25	25	25	25
National Aeronautics and Space Administration								
Operating	4.2	5.9	3.0	3.0	3.0	3.0	3.0	3.0
Direct Personnel	14	15	15	15	15	15	15	15
Department of State								
Operating	0.5	0.9	0.3	0.5	0.5	0.5	0.5	0.5
Direct Personnel	1	1	1	1	1	1	1	1
Environmental Protection Agency								
Operating	0.6	0.8	0.7	1.5	1.5	1.5	1.5	1.5
Direct Personnel	1	2	5	5	5	5	5	5
Other Federal Agencies								
Operating	51.3	17.5	16.5	17.0	17.0	17.0	17.0	17.0
Direct Personnel	69	89	90	90	90	90	90	90
All Other								
Operating	6.6	26.7	23.4	25.0	25.0	25.0	25.0	25.0
Direct Personnel	54	70	77	77	77	77	77	77
<b>Total Work Other Than for DOE</b>								
Operating	378.2	295.5	295.5	300.0	300.0	300.0	300.0	300.0
Direct Personnel	962	892	891	891	891	891	891	891

# Index

## A

aboveground experiments, 5-58, 7-3, 7-20, 7-21, 7-22, 7-27, 7-63  
Accident Response Group, 7-19  
ACCORD project, 7-30, 10-2  
ACRR. *See* Annular Core Research Reactor  
Advanced Computational Technology Initiative, 7-44  
advanced materials, 3-6, 5-5, 5-14, 5-36, 5-44, 5-45, 5-49, 6-6, 7-23, 7-37, 7-50, 7-64  
Advanced Research Projects Agency, 5-2, 5-51, 5-52, 6-7, 7-64  
Aerospace Systems Development Program, 3-5  
agile manufacturing, 3-8, 4-5, 5-2, 5-3, 5-6, 5-7, 5-10, 5-12, 5-14, 5-19, 5-28, 5-30, 5-46, 6-6, 6-7, 6-8, 7-6, 7-31, 7-32, 7-33, 7-64, 8-4  
algorithms  
  for climate modeling, 7-47  
  for combinatorial optimization problems, 5-26  
  navigation, 7-62  
  for target recognition, 5-51  
Alliance for Photonics Technology, 6-4  
American Textile Partnership, 6-4  
Annular Core Research Reactor, 5-48, 7-45  
arms control agreements, 4-1, 7-2, 7-3, 7-7, 7-34  
Assistant Secretary for  
  Defense Programs, 5-3, 5-4, 5-5, 5-6, 5-7, 5-9, 5-10, 5-12, 5-13, 5-17, 5-18, 5-19, 5-20, 5-21, 5-22, 5-23, 5-28, 5-29, 5-30, 5-31, 5-32, 5-36, 5-38, 5-39, 5-51, 5-55, 5-56, 5-57, 5-58, 7-4, 7-8, 13-7, 13-9, 13-10  
  Energy Efficiency and Renewable Energy, 5-3, 5-4, 5-12, 5-34, 5-38, 5-42, 5-44, 5-45, 5-46, 7-40, 13-13, 13-14  
  Energy Research, 5-3  
  Environmental Restoration and Waste Management, 5-3  
  Fossil Energy, 5-3, 5-44, 5-46, 7-43, 13-7, 13-16  
Atmospheric Radiation Measurement, 5-40, 7-52  
automotive applications, 4-6, 5-21, 5-34, 5-35, 5-36, 5-37, 5-55, 6-3, 6-4, 6-10, 6-11, 7-24, 7-42  
aviation industry, 6-6, 7-9, 7-23, 7-66

## B

Ballistic Missile Technology Program, 7-61, 7-62, 7-63  
batteries, 5-22, 5-34, 5-35, 5-37, 5-45, 5-46, 6-4, 7-16, 7-31, 7-34, 7-40, 7-42  
biomedical  
  applications, 4-8, 4-9, 5-11, 5-27, 5-29, 5-32, 5-48, 5-50, 5-51, 5-52, 6-2, 6-10, 7-23, 7-45, 7-47, 7-60  
  systems engineering, 4-7, 5-1, 5-51, 5-52

## C

campus recruiting, 8-3  
capacitors  
  double-layer, 5-35  
  energy storage technologies, 5-46  
carbide powders, 5-45  
Carlsbad Area Office, 7-39

castings, 5-9, 5-26, 6-6, 7-25, 7-31, 7-32, 7-37, 9-8  
catalysts, 5-26, 5-35, 5-44, 5-45, 7-42, 7-43, 7-44, 7-47, 7-49  
ceramics, 3-6, 5-9, 5-17, 5-21, 5-44, 5-45, 6-5, 7-8, 7-25, 7-48, 7-49  
chemical vapor deposition, 3-8, 5-17, 5-26, 6-7, 7-26, 7-48, 7-49  
chemicals, hazardous, 5-22, 5-38  
Class 1 clean space, 5-16, 5-18, 5-20, 6-7  
Clean Car Program, 5-36, 7-42  
climate models, 5-40, 7-43, 7-47, 7-52  
coal research, 7-44, 7-47, 7-48  
College and University Education Outreach, 7-57  
Combustion Dynamics Initiative, 5-48, 5-50  
combustion research, 3-6, 3-8, 5-34, 5-36, 5-37, 5-38, 5-42, 5-47, 5-48, 6-6, 7-41, 7-43, 7-44, 7-46, 7-47, 7-48, 7-65, 10-2  
Combustion Research Facility, 3-8, 5-30, 5-35, 5-38, 5-47, 5-48, 6-5, 6-6, 7-41, 7-43, 7-44, 7-47  
Combustion Research Facility, Phase II, 5-47, 9-9, 9-12  
Communications Hardware Development Center, 5-21, 5-25  
compensation program, 8-4  
competencies, core, 1-2, 3-3, 3-6, 3-7, 4-5, 4-6, 4-7, 5-1, 5-2, 5-12, 5-30, 5-34, 5-35, 5-53, 5-58, 6-1, 6-2, 7-2, 7-18, 7-65  
composite materials, 3-6, 5-2, 5-5, 5-11, 7-8, 7-42, 7-50  
Compound Semiconductor Research Laboratory, 6-4, 6-6, 7-64  
Compound Semiconductor Science and Technology Center, 5-16, 5-19, 5-22, 6-2  
computational  
  manufacturing, 5-28, 5-32  
  simulation, 3-6, 3-7, 3-8, 5-2, 5-7, 5-17, 5-26, 5-28, 5-29, 5-31, 5-55, 6-6, 6-7, 6-10, 7-5, 7-6, 7-8, 7-20, 7-23, 7-25, 7-26, 7-45, 7-47, 7-49, 7-50, 10-2  
Computational Engineering, Center for, 5-26, 5-27, 5-30, 7-47  
computer  
  architecture, 5-22, 5-30, 6-2  
  based design assistant, 5-18  
  based techniques for intelligent machines, 3-6  
  controlled processors, 5-22  
  design of advanced materials, 5-5  
  integrated manufacturing, 5-5  
  models, 5-3, 5-21  
computer-aided design, 3-6, 5-3, 5-7, 5-9, 5-18, 5-36, 5-57, 6-3, 6-10, 7-6, 7-9, 7-33, 7-42, 10-2  
computer-aided engineering, 3-6, 5-57, 6-3, 9-11, 9-12, 10-2, 10-3  
computer-aided manufacturing, 3-6, 5-5, 5-36, 5-57, 7-6, 7-22, 7-33  
computer-aided molecular design, 5-45, 7-42, 7-44  
Computer-Integrated Manufacturing (CIM) Program, 10-2  
computing  
  distributed, 5-30  
  facilities, 3-6, 10-2  
  massively parallel, 3-8, 5-26, 5-27, 5-29, 5-30, 5-31, 5-33, 5-45, 5-51, 7-23, 7-47, 7-52, 7-63, 10-2, 10-4  
  networks, 3-6, 3-7, 5-3, 5-19, 5-22, 5-26, 5-27, 5-28, 5-31, 5-55, 7-23, 7-31, 7-60, 10-2  
conceptual design and assessment, 7-5, 7-7  
concurrent engineering, 3-6, 3-8, 4-5, 5-2, 5-5, 5-7, 5-8, 5-12, 5-13, 5-14, 5-15, 5-57, 7-31, 7-32, 7-33, 7-50  
condition assessment, 9-6  
consequence modeling, 5-55  
Consolidated Waste Management Complex, 9-11, 9-12  
construction projects, 9-5, 9-7, 9-9, 9-12  
containers for hazardous materials, 5-39, 7-8, 7-11, 7-19, 7-29,

7-31, 7-32, 7-34, 7-37, 7-38, 7-43, 7-62, 7-63, 7-66,  
7-67, 7-69

Containment Integrity Program, 7-65  
Contamination-Free Manufacturing, Center for, 5-16, 6-5, 6-6, 6-7  
Continental Scientific Drilling Program, 7-51, 9-11  
Cooperative Monitoring Center, 5-54  
cooperative research and development agreements, 1-2, 3-5, 4-8,  
5-1, 5-2, 5-16, 5-21, 5-28, 5-29, 5-34, 5-51, 6-1, 6-2,  
6-3, 6-4, 6-5, 6-6, 6-8, 6-10, 7-9, 7-22, 7-23, 7-24, 7-25,  
7-42, 7-46, 7-48, 7-50, 10-2, 13-1  
Corporate Diversity Team, 8-6  
Corporate Training and Education Council, 8-4  
countermeasures evaluation activity, 7-63  
counterproliferation, 4-7, 5-53, 5-54, 7-3  
Cummins Engine, 5-46, 5-48  
customers  
focus on, 3-2, 3-3, 3-4, 3-5, 7-3, 7-9, 8-3  
outside DOE, 4-6  
requirements of, 3-1, 3-2, 3-3, 3-4, 3-5, 7-3

## D

data communications, 10-4  
decommissioning and decontamination, 5-39, 5-42, 5-48  
Defense Information Systems Agency, 7-65  
Defense Mapping Agency, 7-62  
Defense Nuclear Agency, 5-58, 6-8, 7-20, 7-21, 7-31, 7-63,  
7-64, 9-10  
Defense Nuclear Facilities Safety Board, 11-3  
Defense Programs, 3-2, 3-5, 3-6, 4-5, 4-6, 4-8, 4-10, 5-1, 5-2,  
5-3, 5-7, 5-10, 5-13, 5-19, 5-24, 5-38, 5-51, 6-5, 6-7,  
6-11, 7-3, 7-4, 7-5, 7-6, 7-10, 7-18, 7-20, 7-23, 7-47,  
11-5, 13-5, 13-7  
Defense Programs Sector, 3-2, 3-5, 5-2, 6-8, 7-2, 7-3, 7-4  
Defense Programs Technology Transfer Initiative, 1-2, 5-29, 7-4,  
7-22, 7-23, 7-25, 13-9  
Department of Agriculture, 5-39, 5-42  
Department of Commerce, 5-4, 6-4, 6-9  
Department of Defense, 3-2, 3-5, 4-7, 5-5, 5-38, 5-39, 5-42,  
5-55, 5-56, 5-57, 5-58, 5-59, 7-4, 7-9, 7-10, 7-12, 7-15,  
7-16, 7-18, 7-20, 7-21, 7-29, 7-30, 7-32, 7-34, 7-35,  
7-60, 7-61, 7-62, 7-63, 7-64, 7-66, 9-7, 10-4, 13-6, 13-21  
Department of State, 7-67, 13-6, 13-21  
Department of the Interior, 5-39, 5-42, 7-68  
Department of Transportation, 3-2, 5-34, 5-35, 5-36, 5-39,  
7-66, 13-6, 13-21  
dismantlement, 3-8, 5-2, 5-13, 5-38, 5-57, 7-1, 7-2, 7-4, 7-6,  
7-7, 7-8, 7-9, 7-12, 7-14, 7-18, 7-28, 7-29, 7-32, 7-34,  
7-35, 7-63  
displays  
active-matrix, liquid-crystal, 5-20  
advanced, 5-20  
flat-panel, 5-2, 5-12, 5-19, 5-20, 5-21, 5-25, 5-27, 6-8,  
7-22, 7-23, 7-26, 7-64  
intelligent, 5-16  
technology, 5-7, 5-19  
virtual work space, 5-7, 5-8  
Distance Learning Program, 8-4  
distributed  
audio-video environment, 5-28  
components, 5-30  
computing, 5-26, 5-30, 5-31  
diversity programs, 8-6  
Doctoral Study Program, 8-4

DoD Reliability Without Hermeticity Program, 5-21  
DOE Carlsbad Area Office, 7-39  
DOE Directives Improvement Project, 4-10  
DOE Directives Management Board, 4-10  
DOE Forum for Industrial High-Performance Computing, 5-30  
DOE Laboratory Technology Partnership Act of 1992, 5-5  
Drell Panel, 7-4, 7-14  
Drug Abuse Act of 1989, 7-68  
dual-benefit, 1-2, 3-6, 3-8, 4-6, 4-7, 4-9, 5-2, 5-4, 5-10,  
5-11, 5-12, 5-18, 5-19, 5-23, 5-47, 5-51, 5-57, 6-2, 6-5,  
7-3, 7-8, 7-9, 7-12, 7-23, 9-11

## E

Education Outreach, 4-11, 7-20, 7-53, 7-54, 7-55, 7-56, 7-57,  
7-58, 7-59, 8-6  
Ekofisk Field, 7-44  
electric energy systems, 7-40, 13-13  
Electric Power Research Institute, 5-35, 5-44, 6-4  
electric vehicles, 5-35, 5-37, 6-4, 7-42  
Electrical Upgrade/Second Source (New Mexico), 9-10, 9-12  
electromagnetic  
analysis, 5-21  
codes, 3-7  
pulse sensors, 5-54  
radiation contamination, 5-16  
synthesis and processing, 5-5  
electromechanical  
component fabrication, 5-4  
product design, 5-7  
Electronics Industrial Association, 5-21  
Electronics Quality Reliability Center, 6-5, 6-10  
electronics technology, 1-2, 3-6, 3-7, 3-8, 4-4, 4-5, 4-6, 4-7,  
4-8, 5-1, 5-3, 5-12, 5-16, 5-17, 5-18, 5-19, 5-20,  
5-21, 5-24, 5-25, 5-38, 5-42, 6-4, 6-11, 7-3, 7-7, 7-8,  
7-9, 7-16, 7-20, 7-21, 7-24, 7-30, 7-46, 7-64  
Electronics Technology Center, 5-17, 5-18, 5-24  
Emergency Response Program, 5-40, 7-7  
emissions control, 5-34, 5-35, 5-36, 5-37, 5-45, 7-23, 7-24,  
7-41, 7-42, 7-49  
Emissive Flat-Panel Display Technology Center, 5-19, 5-20, 5-25  
Employee Development Center, 8-2  
encryption technology, 7-15  
energy, 3-2, 4-1, 4-3, 4-6, 5-3, 5-4, 5-12, 5-15, 5-34, 5-35,  
5-36, 5-42, 5-44, 5-45, 5-46, 5-47, 5-48, 5-49, 7-40,  
7-45, 7-46, 7-48, 7-49, 7-59, 13-13  
Energy and Environment Sector, 3-2, 3-3, 3-5, 4-3, 4-6,  
5-36, 6-2, 7-23, 7-24, 7-40, 11-4, 11-5  
Energy Programs, 5-1, 7-40, 13-6, 13-7  
energy research and technology development, 5-1, 5-42, 5-49,  
5-50  
energy security, 4-4, 4-6, 4-7, 4-8, 5-4, 5-35, 5-42, 7-40  
Engine Combustion Technology Project, 5-35  
engineered materials, 3-6, 4-7, 5-22, 5-35, 5-52, 7-6  
engineering  
development projects, 7-12  
information systems, 7-30  
sciences, 3-6, 4-7, 7-51  
Engineering Integration Center, 10-2  
Engineering Science Center, 10-4  
Enhanced Transportation Surety Initiative, 5-55, 5-59  
entrepreneurial initiatives, 6-3, 6-9  
environment, safety, and health, 3-3, 4-6, 4-11, 5-36, 5-48,  
5-57, 7-2, 7-4, 7-6, 7-12, 7-14, 7-30, 7-45, 8-4, 9-5, 9-7,

9-9, 11-1, 11-2, 11-3, 11-4, 11-5, 11-6, 11-8  
 Environmental Extension Enabling Program, 5-5, 6-9  
 Environmental Monitoring Systems Laboratory, 7-68  
 Environmental Operations Center, 11-4  
 Environmental Programs, 5-1  
 Environmental Protection Agency, 5-4, 5-38, 6-9, 7-36, 7-37,  
 7-38, 7-39, 7-59, 7-67, 7-68, 11-4, 11-7, 11-8, 13-6, 13-21  
 Environmental Restoration Program, 4-11, 5-39, 5-41, 7-36,  
 7-37, 7-68, 11-4  
 environmental technology, 4-6, 5-1, 5-34, 5-37, 5-38, 5-41,  
 7-41, 7-68  
 environmentally conscious manufacturing, 3-7, 4-1, 4-5, 4-6,  
 5-2, 5-4, 5-5, 5-12, 5-14, 5-16, 5-18, 5-38, 5-41, 5-42,  
 5-43, 5-57, 6-6, 6-7, 6-9, 7-10, 7-14, 7-22, 7-23, 7-28,  
 7-33, 7-36, 7-37, 7-68  
 Environmentally Conscious Process Center, 6-7  
 equal employment opportunity, 8-5  
 Equipment Design Support Center, 5-16  
 European Space Agency, 7-66, 7-67  
 expert systems, 5-4, 5-13, 5-18, 6-7  
 Explosive Components Facility, 9-7, 9-12  
 explosives, 5-56, 7-5, 7-8, 7-10, 7-12, 7-20, 7-29, 7-32, 9-7

## F

facilities and maintenance, 3-5, 3-8, 3-9, 6-5, 9-1, 9-3, 9-4, 9-5,  
 9-6, 9-7, 9-8, 9-11  
 Faculty Education Outreach Programs, 7-59  
 Fail-Safe and Risk Reduction (FARR) Study, 5-55, 7-14, 7-15  
 FASTCAST program, 5-10, 7-25, 7-32  
 Federal Aviation Administration, 7-66  
 Federal Facilities Compliance Act of 1992, 11-4  
 Fine Particle Catalyst Program, 7-44  
 focal efforts, 5-55  
 Focal Point program, 7-17  
 focus areas, 5-1, 7-2, 7-3, 7-4  
 Foreign Operations Appropriations Act of 1994, 6-5  
 foreign technology assessment, 7-35  
 former Soviet Union, 4-1, 5-34, 5-53, 5-58, 6-5, 7-2, 7-3, 7-12,  
 7-18, 7-29, 7-31  
 fossil energy, 5-36, 5-42, 5-43, 5-46, 7-40, 7-43, 7-45, 7-51  
 Freedom Support Act, 5-58  
 fuel cells, 5-35, 5-37, 5-45, 5-47, 7-43  
 funding  
 Assistant Secretary for Defense Programs, 13-5, 13-7, 13-9,  
 13-10  
 Assistant Secretary for Energy Efficiency and Renewable Energy,  
 13-7, 13-13, 13-14  
 Assistant Secretary for Fossil Energy, 13-7, 13-16  
 Assistant Secretary for Nuclear Energy, 13-7, 13-17  
 Construction Projects, 9-12  
 DOE Effort, 13-4  
 Magnetic Fusion Program, 13-18  
 Office of Basic Energy Sciences, 13-18  
 Office of Civilian Radioactive Waste Management, 13-7, 13-15  
 Office of Economic Impact and Diversity, 13-8, 13-20  
 Office of Energy Research, 13-8, 13-18  
 Office of Environmental Restoration and Waste Management,  
 13-5, 13-7, 13-12  
 Office of Nonproliferation and National Security, 13-5, 13-7,  
 13-11  
 Office of Science Education and Technical Information, 13-8,  
 13-19  
 Science and Technology Programs, 13-8

work-for-others, 13-4, 13-8, 13-20, 13-21  
 fusion technologies, 7-27, 7-28  
 fuzzy searches, 5-31

## G

gas boosting systems, 7-16  
 gas generation experiments, 7-38  
 General Motors Company, 6-4  
 general plant projects, 9-6, 9-7, 13-1, 13-3  
 geographic information systems, 5-34, 5-36, 5-39, 7-38  
 Geoscience Research Drilling Office, 7-51  
 Geosciences Research Laboratory, 9-11, 9-12  
 geothermal systems, 7-40, 13-13  
 Global Change Research Program, 7-52  
 Global Climate Change Plan, 5-42  
 Graduate Students Education Outreach, 7-58  
 Greater Confinement Disposal Project, 5-38, 7-39

## H

health care, 8-3  
 health management program, 11-8  
 Hermes III gamma-ray accelerator, 3-7, 3-8, 7-21, 7-27, 7-28,  
 7-63  
 high-bandwidth technology, 5-22, 5-32  
 high-performance communications, 5-2, 5-19, 5-21, 5-29, 5-30,  
 5-32, 5-52, 7-47, 9-11, 10-4  
 high-performance computing, 3-7, 4-7, 5-19, 5-22, 5-26, 5-28,  
 5-29, 5-30, 5-31, 5-51, 5-52, 7-3, 7-23, 7-47, 9-11, 10-2  
 High-Power Radio Frequency Phase 2 study, 7-12  
 high-reliability systems, 5-12, 5-20  
 high-speed digital circuits, 5-22  
 high-technology industries, 6-3  
 Hobart Brothers Company, 6-11  
 Hot Cell Facility, 5-48, 7-45  
 House Government Operations Committee, 5-48  
 human genome project, 5-51  
 human resources, 1-2, 3-4, 3-9, 4-4, 4-10, 8-1, 8-3, 11-5  
 hybrid microcircuits, 5-17, 5-21, 6-5  
 hybrid vehicles, 5-35, 5-37, 7-42  
 hydrodynamic experiments, 7-20, 7-21, 7-27  
 hydrogen  
 energy, 5-34, 5-35, 5-45, 5-47, 5-50, 7-44  
 research, 13-13  
 sensors, 6-11, 7-26, 7-67

## I

IAEA. *See* International Atomic Energy Agency  
 Idaho National Engineering Laboratory, 7-39  
 ignition facility, 7-27  
 Industrial High-Performance Computing Applications, 5-29, 5-30,  
 5-32  
 Industrial Technologies Program, 7-42  
 Industrial Waste Reduction Program, 3-2, 5-12, 7-42  
 Industries of the Future Initiative, 5-3, 5-4  
 inertial  
 confinement fusion, 3-7, 4-8, 7-4, 7-27, 7-28, 13-9  
 navigation systems, 7-61  
 information  
 and analysis, 3-3  
 dissemination, 3-2, 3-3, 5-4, 5-5, 5-28, 5-31, 6-1, 6-9,  
 10-6, 11-2

driven manufacturing, 5-3, 5-8, 5-14, 5-28, 6-7, 7-33  
 infrastructure, 4-4, 5-28  
 initiatives, 4-8  
 management, 7-34, 7-35, 7-36, 10-1, 10-2, 10-3, 10-5, 10-6, 11-6  
 sciences, 3-6, 4-7, 5-3, 5-30  
 systems, 3-5, 5-2, 5-39, 10-3  
 technology, 1-2, 3-7, 4-3, 4-4, 4-5, 4-6, 4-7, 4-8, 5-1, 5-3, 5-26, 5-31, 5-32, 5-33, 5-53, 6-7, 7-23, 7-45, 7-46, 7-64, 10-1, 10-3  
**infrastructures**  
   communications, 3-8, 4-4, 4-10  
   information, 4-4, 4-10, 5-31  
   national, 4-3  
   production, 5-14  
   research, 4-3  
   technology, 7-2  
**In-Hours Technical Education Program, 8-4**  
**In-House Energy Management (IHEM) Program, 9-6**  
**instrumentation**  
   adaptive control, 7-9  
   advanced, 5-41, 7-22, 9-11  
   biomedical applications, 7-23  
   cavern monitoring, 7-44  
   climate research, 5-40, 7-52  
   combustion studies, 5-47  
   and control technology, 7-63  
   flight, 7-12, 7-60, 7-61, 7-63  
   geophysical, 7-43  
   geothermal wells, 7-40  
   magnetic fusion energy, 7-46  
   Nevada Test Site, 7-21  
   reentry body, 7-62  
   robotics, 5-6  
   satellite, 7-60  
   space-based experiments, 7-66, 7-67  
**integrated capabilities, 3-6, 5-1, 5-26, 12-2. See also strategic thrusts**  
   advanced information technology, 3-7, 4-4, 4-5, 4-7, 4-8, 7-46  
   advanced manufacturing technology, 3-6, 4-4, 4-5, 4-7, 4-8, 4-9, 7-46  
   electronics technology, 3-6, 4-4, 4-5, 4-7, 4-8, 7-46  
   pulsed power technology, 3-7, 4-4, 4-5, 4-7, 4-8  
**integrated circuits, 3-6, 5-16, 5-17, 5-18, 5-19, 5-20, 5-21, 5-22, 5-24, 6-2, 6-5, 6-6, 6-7, 6-8, 6-10, 6-11, 7-9, 7-26, 7-27, 7-64, 7-67**  
**Integrated Manufacturing Technologies Laboratory, 3-8, 5-2, 5-17, 6-6, 6-7**  
**Integrated Materials Research Laboratory, 3-8**  
**integrated services management system (ISMS), 11-6**  
**Integrated Transportation Initiative, 5-36**  
**intellectual property development and licensing, 6-9**  
**intelligence support activities, 7-35**  
**intelligent**  
   knowledge-based systems, 6-4  
   machines, 3-6, 5-2, 5-3, 5-7, 5-10, 5-17  
   manufacturing, 5-3, 5-5, 5-6, 5-7, 5-14, 6-7, 7-6, 7-22  
   materials, 5-10  
   microelectronics, 5-19  
   micromachines, 5-16, 5-23, 5-24, 5-25  
   processors, 5-22  
   production systems, 5-3  
   sensors, 5-10, 5-16  
   system interfaces, 5-28  
   vehicle and highway system, 5-35, 5-36, 7-66

**Intelligent Systems and Robotics Center, 6-7**  
**interactive virtual reality environment, 5-7**  
**intercontinental ballistic missile force, 7-28**  
**interfacial adhesion, 7-49**  
**Intermediate-Range Nuclear Force Treaty, 5-53**  
**Intermodal Surface Transportation Efficiency Act of 1991, 5-34, 7-66**  
**International Atomic Energy Agency, 5-53, 7-35, 7-67**  
**International Thermonuclear Experimental Reactor, 7-46, 7-47**  
**Interop Achievement Award, 5-28, 10-4**  
**intrasite secure transport vehicle prototype, 7-18**  
**Investment Casting Addition, 9-8, 9-12**  
**ion implantation, 3-8, 5-17, 6-7**  
**Isotope Production and Distribution Program, 5-48**

## J

**joining technologies, 4-8, 5-17, 5-20, 5-44, 5-45, 6-7, 6-11, 7-17, 7-23, 7-50**  
**Jupiter Pulsed Power Facility, 5-58, 5-59, 7-21, 9-3, 9-10, 9-12**

## K

**Kauai Rocket Test Facility, 3-10, 5-55, 7-63, 9-1, 11-3, 11-8**

## L

**Laboratory-Directed Research and Development Program, 3-3, 3-7, 4-5, 5-52, 13-6**  
**large helical device, 7-47**  
**lasers, 5-9, 5-16, 5-48, 6-4, 6-6, 7-7, 7-8, 7-14, 7-18, 7-23, 7-27, 7-34, 7-41, 7-42, 7-48, 7-49, 7-52, 7-60, 9-9**  
   gas-phase, 3-8  
   solid-state, 3-8  
   vertical cavity, 5-16, 5-22  
   welding, 6-11  
**LDRD. See Laboratory-Directed Research and Development Program**  
**Leadership and Management Development Program, 8-3**  
**life-cycle environmental designs, 6-7**  
**Light Water Reactor Technology Center, 7-45**  
**light-ion inertial confinement fusion, 7-27**  
**Limited Test Ban Treaty, 5-53**  
**limited-life components, 7-2, 7-11, 7-12, 7-13, 7-21, 7-28, 7-29**  
**Liquid Metal Processing Laboratory, 9-8**  
**Liquid-Metal Processing Technology, Center for, 6-6**  
**lithography, 5-9, 5-10, 5-16, 5-17, 6-6, 6-7, 7-22, 7-26**  
**Los Alamos National Laboratory, 5-46, 5-53, 5-56**  
**Low Emissions Partnership, 5-36**

## M

**Magnetic Fusion Program, 7-46, 13-18**  
**magnetic resonance imaging, 5-51, 5-52**  
**Malcolm Baldrige National Quality Award, 1-2, 3-1, 3-2**  
**Manufacturing Science and Engineering Laboratory, 5-6**  
**manufacturing technology, 1-2, 3-6, 3-8, 4-3, 4-4, 4-5, 4-6, 4-7, 4-8, 4-9, 5-1, 5-2, 5-3, 5-4, 5-5, 5-6, 5-7, 5-10, 5-12, 5-13, 5-14, 5-15, 5-17, 5-18, 5-19, 5-28, 5-30, 5-37, 5-43, 5-46, 5-57, 5-58, 6-2, 6-4, 6-5, 6-6, 6-7, 6-8, 7-3, 7-22, 7-23, 7-26, 7-28, 7-30, 7-31, 7-33, 7-36, 7-42, 7-46, 7-48, 7-64, 9-6, 10-2**  
**Manufacturing Technology Centers, 1-2, 5-5**  
**Martek Lasers, Inc., 6-11**  
**Martin Marietta Corporation, 3-4, 4-10, 6-9, 7-58**



Massively Parallel Computing Research Laboratory, 5-26, 5-29, 5-30, 7-47

materials

- advanced. *See* advanced materials
- analysis, 3-8, 5-21, 7-9, 7-32
- applications, 5-26
- ceramic, 3-6
- characterization, 7-8
- composite, 3-6
- crystalline silicotitanate ion-exchange, 5-45
- development of, 3-6, 5-5, 5-10, 5-35, 7-8
- electronic, 7-24
- energetic, 7-12, 7-18, 7-20, 7-48, 7-64
- engineering, 6-2
- epitaxial, 6-10, 7-48, 7-49
- joining and sealing of, 4-8, 5-17
- low friction coefficients, 3-7
- nuclear, 5-2, 7-1, 7-2, 7-8, 7-23
- optoelectronics, 5-19, 6-2
- polymeric, 5-26
- porous, 5-45
- processing, 3-7, 3-8, 5-5, 5-11, 6-6, 7-23, 7-41, 7-50
- research and development, 5-2, 5-5, 5-11, 5-21, 6-4, 6-6, 6-7, 7-25, 7-42
- science, 5-16, 5-23, 5-45, 5-56, 6-8, 7-3, 7-7, 7-10, 7-18, 7-48, 7-49, 7-50, 7-64
- scientifically tailored, 7-46, 7-47, 7-48, 7-49
- synthesis, 3-8, 5-5, 5-21, 7-42, 7-47, 7-48, 7-49, 7-50, 7-64
- technology, 5-22, 5-44, 7-8, 7-31
- testing of, 5-58, 7-21

Melting and Solidification Laboratory, 6-5

- melting processes, 7-25
- membranes, 5-44, 5-45
- mesh generation, 5-26, 5-28, 5-29, 5-36, 6-3, 6-10, 7-23
- metacomputing environment, 5-27, 5-30, 5-31, 5-32
- microcircuits, 5-17, 5-21
- microelectronics and photonics, 3-6, 4-5, 4-7, 4-8, 5-4, 5-16, 5-17, 5-18, 5-19, 5-21, 5-22, 5-30, 5-54, 6-2, 6-4, 6-5, 6-8, 6-11, 7-7, 7-8, 7-9, 7-14, 7-16, 7-24, 7-26, 7-27, 7-36, 7-60, 7-61, 7-62, 7-64, 7-66, 7-69
- Microelectronics Development Laboratory, 5-16, 5-17, 5-18, 5-20, 5-23, 5-24, 6-2, 6-6, 6-7, 7-64, 7-65
- Microelectronics Quality and Reliability Center, 5-16, 7-64
- Microelectronics Technologies, Center for, 3-8, 5-16, 5-18, 5-19, 5-24, 5-30, 6-2, 6-6, 7-64
- microfusion facility, 7-27
- microsensors, 6-2, 7-7, 7-67
- Microsensors Research and Development Laboratory, 5-17
- military liaison activities, 7-10, 7-28
- Minority Economic Impact Program, 13-20
- minority education outreach programs, 7-57, 7-58
- Missile Defense Act of 1991, 7-63
- modeling
  - combustion research, 5-48
  - complex phenomena, 3-8
  - computational simulation, 5-26, 7-5, 7-6, 7-23
  - molecular, 7-42
  - production processes, 7-31
  - tools for electronic products, 5-18
- molecular beam epitaxy, 3-8, 5-17, 6-6
- molybdenum-99, 4-9, 5-48, 7-45
- Motorola, 6-10, 7-9
- multichip modules, 5-17, 5-19, 5-21, 5-22, 6-7

Munitions Technology Development Program, 7-4, 7-18, 7-64

## N

National Aeronautics and Space Administration (NASA), 3-2, 7-52, 7-59, 7-66, 7-67, 13-6, 13-21

National Aging Aircraft Program, 6-6

National Biomedical Engineering Collaboration, 5-51, 5-52

National Center for
 

- Advanced Information Components Manufacturing, 3-8, 5-2, 5-30, 6-7, 7-64
- Advanced Manufacturing Technology, 5-2, 6-8
- Manufacturing Sciences, 5-18, 5-21, 6-4
- Risk Assessment, 5-56, 5-57, 5-59
- Ultra-Reliability Engineering, 5-12, 5-16, 6-8

National Competitiveness Technology Transfer Act of 1989, 6-1

National Consortium for High-Performance Computing, 5-31

National Contingency Plan, 7-37

National Energy Policy Act of 1992, 5-44

National Information Infrastructure Initiative, 5-18, 5-22

National Information Infrastructure Test Bed, 5-31, 5-33

National Institute of Justice, 7-68

National Institute of Standards and Technology, 1-2, 5-5, 5-18, 5-51, 6-4, 6-5, 6-9

national laboratories, 3-3, 4-1, 4-3, 5-12, 5-34
 

- core competencies, 6-1
- role of, 1-1, 7-3

National Laboratory Stabilization Partnerships, 6-5

National Machine Tool Partnership, 6-5

National Medical Information and Communications System Design, 5-52

National Optoelectronics Initiative, 5-19, 5-24

National Photovoltaic Program, 5-43

National Security Agency, 7-68

National Security and Arms Control, Center for, 9-9, 9-12

National Security Decision Directive, 7-15

National Solar Thermal Test Facility, 3-8, 5-42, 6-5, 6-8, 7-40

National Transuranic Program, 7-39

Natural Gas and Oil Technology Partnership, 5-46

Natural Gas Program, 7-44

Navy Pacific Missile Range, 9-1, 11-8

nCUBE 2, 5-26

nCUBE 3 supercomputer, 5-31

NCURE. *See* National Center for Ultra-Reliability Engineering

Nevada Operations Office, 7-39, 7-59

Nevada Test Site, 5-38, 5-55, 7-16, 7-20, 7-21, 7-39, 7-59, 10-5, 11-8

Newly Independent States Partnerships, 5-58, 13-9

NIRVANA project, 7-30, 10-2

nondestructive testing, 5-12, 5-44, 6-6, 7-9, 7-34, 7-66

nonnuclear components, 4-8, 4-9, 5-2, 5-38, 5-57, 5-58, 5-59, 7-6, 7-10, 7-33, 7-36, 9-8

Nonnuclear Consolidation (New Mexico), 9-8, 9-12

nonproliferation, 4-5, 5-53, 5-58, 6-5, 7-2, 7-3, 7-4, 7-12, 7-18, 7-34, 7-35, 7-67, 13-11

Novel Superconductors Project, 7-48

Nuclear Command and Control System Decision Directive, 7-16

Nuclear Effects Safeguards Program, 7-21

Nuclear Emergency Search Team, 7-20

nuclear energy research and development, 7-45

nuclear medicine, 5-48, 5-50, 7-45

Nuclear Regulatory Commission, 3-2, 5-42, 7-43, 7-45, 7-65, 13-6, 13-21

nuclear safety, 5-56, 5-57, 5-58, 6-11, 7-1, 7-3, 7-4, 7-5, 7-6,

7-14, 7-15, 7-16, 7-18, 7-19, 7-20, 7-28, 7-29, 7-30, 7-64, 10-2

Nuclear Waste Complex Technologies Development, 7-33

Nuclear Waste Fund, 7-42, 13-15

Nuclear Waste Policy Act of 1982, 7-39

nuclear weapons. *See also* weapons

- certification of, 7-20
- command and control, 3-7, 4-8, 5-19, 5-28, 5-30, 5-36, 5-55, 5-56, 5-59, 7-7, 7-10, 7-12, 7-15, 7-16, 7-18, 7-35, 7-60, 7-63, 7-65, 7-68, 7-69
- communication over wireless links, 5-22
- complex, 5-3, 5-55, 5-57
  - advanced rapid manufacturing, 5-10
  - computational manufacturing, 5-28
  - concurrent engineering practices, 5-13
  - environmentally conscious manufacturing, 5-4, 5-12
  - information surety, 5-30
  - manufacturing needs of, 3-6, 5-2, 6-8
  - missions and responsibilities, 4-5
  - optoelectronics, 5-19
  - problems facing, 5-2
  - research and development, 4-2
  - restructuring of, 3-6, 4-2, 4-5, 4-8, 5-5, 5-7, 5-12, 5-55, 5-57, 7-1, 7-2, 7-3, 7-6, 7-12, 7-28, 7-31, 7-33, 7-34, 9-9, 10-5, 13-10
  - sensors applications, 5-22
  - weapon product realization, 5-13
- components, 5-55, 5-56, 5-58
  - design, 5-5, 5-13, 5-19, 7-5, 7-14, 7-33
  - development of, 7-9, 7-10, 7-17, 7-24
  - disposal and recycling of, 5-2, 7-8, 7-10, 7-12, 7-28, 7-32, 7-36
  - domestic manufacturers, 5-18, 5-57, 7-28, 7-33
  - effects, 3-8, 5-58, 7-20, 7-63
  - electronic, 5-16, 5-17, 7-16
  - external industrial suppliers, 5-5
  - life cycle, 5-2, 5-13, 5-17, 7-6, 7-9, 7-10, 7-36
  - prototypes, 5-4
  - reliability of, 3-5, 5-12, 5-16, 7-5, 7-7, 7-11, 7-20, 7-21
  - transportation, 5-55, 7-31
- computational support, 7-5
- defects, 7-10
- design, 4-5, 5-2, 5-3, 5-13, 5-26, 7-4, 7-10, 7-63
- development, 4-1, 4-5, 7-10, 7-22, 7-62
- production of, 3-2, 3-8, 4-5, 4-9, 5-5, 5-10, 5-12, 5-13, 5-14, 5-38, 5-53, 5-57, 7-1, 7-2, 7-3, 7-4, 7-6, 7-8, 7-10, 7-12, 7-31, 7-33, 7-34, 7-36
- program, 3-5, 4-3, 4-7, 5-52, 7-3, 7-20, 7-36, 7-60, 7-65, 7-66
- reliability of, 3-6
- service lives, 5-12, 7-2, 7-5, 7-31
- stewardship, 4-2, 7-2
- transportation, 5-36, 5-55, 7-9, 7-14, 7-18, 7-19, 7-31, 7-34, 7-35, 7-62

Nunn-Lugar Act, 5-58

## O

Occupational Safety Program, 11-8

Office of

- Basic Energy Sciences, 5-36, 7-46, 7-47, 7-48, 13-18
- Civilian Radioactive Waste Management, 3-2, 5-6, 7-42, 7-43, 13-6, 13-7, 13-15
- Economic Impact and Diversity, 13-8, 13-20

- Energy Efficiency and Renewable Energy, 3-2, 5-36, 5-45, 5-47, 6-6, 7-47, 13-6
- Energy Research, 3-2, 5-7, 5-30, 5-40, 5-47, 6-6, 7-46, 13-6, 13-8, 13-18
- Environmental Restoration and Waste Management, 3-2, 5-6, 5-38, 5-39, 6-7, 7-6, 7-7, 7-8, 7-36, 7-37, 9-7, 11-4, 11-5, 13-6, 13-7, 13-12
- Export Control, 7-35
- Foreign Intelligence, 7-35
- Fossil Energy, 3-2, 7-44, 7-47, 13-6
- Health and Environmental Research, 5-51, 5-52, 7-45, 7-46
- Military Application, 7-27, 10-2
- Nonproliferation and National Security, 3-2, 5-53, 5-55, 5-58, 7-5, 7-6, 7-34, 13-7, 13-11
- Nonproliferation Policy, 7-35
- Nuclear Energy, 3-2, 5-38, 5-42, 5-48, 7-45, 13-6, 13-7, 13-17
- Science Education and Technical Information, 7-53, 13-6, 13-8, 13-19
- Scientific Computing, 5-26, 7-46
- Solar Electric Conversion, 5-43, 5-44
- Utility Technology, 5-42
- Waste Reduction, 7-59
- Office of the Strategic Petroleum Reserve, 7-43
- OIDA. *See* Optoelectronics Industry Development Association
- oil recovery, 5-42, 5-46, 7-44
- One-Year-on-Campus Program, 7-58, 8-4, 8-7
- Operational Deployment Experiment Simulator, 7-63
- optoelectronics, 5-2, 5-5, 5-17, 5-19, 5-21, 5-22, 5-26, 6-2, 6-3, 6-4, 6-6, 6-8, 6-10, 7-9, 7-16, 7-26, 7-49, 7-64
- Optoelectronics Industry Development Association, 5-16, 5-19, 6-2
- Outreach Centers, 9-9, 9-12
- Outreach/Inreach, 8-6

## P

- packaging, electronics, 3-6, 5-16, 5-20, 5-21, 5-25, 5-38, 6-8, 6-11, 7-64
- PALs. *See* permissive action links
- Pantex plant, 3-9, 3-10, 5-6, 7-11, 7-12, 7-16, 7-30, 7-32, 7-33, 7-34, 7-59
- parachute systems, 7-62, 7-67
- Particle Beam Fusion Accelerator II, 3-7, 3-8, 7-27
- Partnership for a New Generation of Vehicles, 5-36, 5-37
- PEPER. *See* Propellants, Explosives and Pyrotechnics Evaluation and Reapplication Project
- performance assessment, 5-34, 5-38, 7-38, 7-39, 7-43, 7-65
- permissive action links, 5-56, 7-13, 7-15, 7-16, 7-29
- personnel
  - degrees of, 3-9
  - summary by major sponsor, 13-6
- Petroleum Program, 7-44
- PHA. *See* preliminary hazard assessment
- P-HEMTs. *See* pseudomorphic, high-electron-mobility transistors
- Phillips Laboratory, 7-61
- photonics. *See* microelectronics and photonics
- Photovoltaic Manufacturing Technology Program, 5-43
- Photovoltaic Systems Design Assistance Center, 5-42, 7-41
- photovoltaics, 3-8, 5-42, 5-43, 5-44, 5-49, 7-40, 7-41, 7-67
- physics program element, 7-5
- Pit Reuse for Enhanced Safety and Security (PRESS), 7-14
- Pittsburgh Energy Technology Center, 7-44
- planning
  - environment, safety, and health, 11-5
  - human resources, 8-1

site development, 9-3  
   strategic, 1-1, 3-3, 3-4, 3-9, 4-1, 4-2, 4-4, 7-2, 7-4, 8-1, 10-1  
 Plasma Materials Test Facility, 7-46  
 PNGV. *See* Partnership for a New Generation of Vehicles  
 pollution prevention operations, 7-39  
 Portsmouth Gaseous Diffusion Plant, 7-59  
 Post-Cold War Defense Imperatives, 5-1, 5-53, 5-59  
 Power Systems Modernization (New Mexico), 9-8, 9-12  
 precision engineering, 6-2, 7-22  
 Pre-College Education Outreach Programs, 7-53  
 precompetitive information, 5-31  
 precompetitive research and development, 3-6, 4-6, 5-36, 6-2  
 precompetitive technology, 5-16, 5-19, 5-20, 6-2, 6-3, 6-4,  
   7-5, 7-9  
 preliminary hazard assessment (PHA), 11-2, 11-4  
 PRESS. *See* Pit Reuse for Enhanced Safety and Security  
 Price-Anderson Amendments Act, 11-3  
 Primary Standards Laboratory, 7-31  
 PRISM software, 6-11  
 probabilistic risk assessment, 5-36, 5-55, 7-14, 7-15, 7-18, 7-65  
 Process Design Laboratory, 5-20  
 Processing and Environmental Technologies Laboratory, 9-12, 9-9  
 product  
   cycles, 4-1, 4-3, 5-13, 5-28  
   design, 4-1, 5-3, 5-13, 5-18, 5-30  
   quality, 3-4, 3-5, 4-6, 5-57  
   readiness assurance, 5-13, 5-15  
   realization, 3-6, 4-4, 4-5, 4-7, 5-7, 5-10, 5-13, 5-16, 5-17,  
     5-18, 5-19, 5-27, 5-28, 5-57, 7-8, 7-14  
   reliability, 5-4, 7-6  
   surety, 5-18  
 programs  
   declining resources, 4-2  
   management of, 4-4, 4-7, 4-10  
   responsibilities, 4-4  
 project  
   initiatives, 5-3, 5-28, 5-34, 5-38  
   management, 3-5, 5-13  
   planning, 3-3  
 proliferation detection, 5-53, 5-54, 7-2, 7-3, 7-7, 7-34, 7-35,  
   7-60, 7-67  
 Proliferation Research Program, 5-53, 5-55, 5-59  
 Propellants, Explosives, and Pyrotechnics Evaluation and  
   Reapplication Program, 7-20  
 protection systems, 12-2, 12-3  
 Proto II, 7-27  
 prototypes  
   advanced systems, 3-8, 5-7  
   applications, 5-13  
   castings, 7-25  
   communications hardware, 5-22  
   device development, 5-11, 6-10  
   electronics, 5-17, 5-20  
   fabrication of, 5-2, 6-7, 7-34  
   hardware, 5-5, 5-10  
   information-driven manufacturing, 5-3  
   life-cycle analysis tools, 5-4  
   manufacturing of, 5-17, 6-5  
   physical, 5-9, 5-18  
   rapid. *See* rapid prototypes  
   simulation of, 5-28  
   software, 5-7  
 pseudomorphic high-electron-mobility transistors (P-HEMTs), 5-16,  
   5-22

pulsed power, 3-6, 3-7, 3-9, 4-4, 4-5, 4-7, 4-8, 5-58,  
   7-18, 7-21, 7-27, 7-28, 7-62, 7-63, 9-6, 10-2  
 pyrotechnics, 7-20

## Q

Qualification Evaluation Information Center, 7-29  
 quality  
   assurance, 3-9, 7-29, 7-30, 11-3  
   management, 1-2, 3-1, 3-2, 3-3, 3-4, 4-9, 4-11, 11-1  
   policy, 3-1  
   principles, 3-4, 3-9  
   research and development, 5-12  
 quantum chemistry, 5-26  
 quantum electronics, 6-4

## R

radiation effects, 4-8, 5-58, 7-3, 7-20, 7-21  
 radiation hardness, 7-10, 7-22, 7-27, 7-32, 7-60, 7-61, 7-63,  
   7-66, 7-67  
 Radiation Protection Program, 11-8  
 radiopharmaceutical industry, 5-48  
 rapid  
   cycle time, 5-13  
   fabrication, 5-10  
   manufacturing, 5-9, 5-10, 5-15  
   prototypes, 5-5, 5-9, 5-10, 5-17, 5-20, 5-26, 5-28, 5-29,  
     5-30, 5-55, 6-5, 6-6, 7-25, 7-30, 7-33, 7-60, 9-6  
   sampling and analysis techniques, 5-39  
 real-time  
   data, 5-7, 5-39  
   diagnostics for materials processing, 5-5  
   imaging, 5-22  
   visualization of simulation data, 5-28  
 records management, 5-52, 10-5, 10-6, 11-7  
 reimbursable sponsors, 3-5, 5-1, 6-8, 7-1, 7-68  
 reliability  
   electronics packaging, 5-21  
   engineering, 5-12, 5-16, 6-8  
   of nuclear weapons, 3-5, 4-3, 7-5, 7-8, 7-14, 7-21, 7-28,  
     7-30, 7-31  
   physics, 5-12, 5-16  
   simulation, 5-28  
   soft spots, 7-12  
   technology, 5-12, 5-15, 5-17, 6-6, 6-8, 7-27  
 remediation of contaminated sites, 4-2, 4-3, 4-6, 4-8, 5-38,  
   5-39, 7-2, 7-4, 7-8, 7-33, 7-37, 7-67, 7-68, 9-7, 11-3,  
   11-57, 11-62, 7-64  
 remote sensing, 3-5, 3-8, 4-6, 5-22, 5-40, 6-6, 7-34, 7-52,  
   7-62, 7-64  
 Remote Sensing and Verification Program, 3-5  
 repositories, 3-5, 5-38, 5-39, 5-42, 7-36, 7-38, 7-39, 7-42,  
   7-43, 11-8  
 Research and Advanced Technology Program, 7-5  
 research and development  
   biomedical applications, 5-51  
   defense programs sector, 7-2, 13-9  
   electronics technology, 5-17  
   energy supply industry, 4-3  
   experimental and analytical, 5-11  
   information surety, 5-30  
   manufacturing technology, 5-2  
   materials science, 6-7, 7-50

nuclear energy, 7-45  
 objectives, 4-8  
 partnerships, 6-2, 6-3  
 safety technology, 7-15  
 science and technology programs, 7-46  
 technology transfer, 4-3, 4-8, 6-1  
 transportation technologies, 5-35  
 weapon products, 7-17  
 biomedical applications, 5-51  
 for industry, 5-16  
 Research and Development 100 Award, 5-21, 7-47, 10-4  
 research foundations, 3-6, 4-4, 4-7, 4-8  
 computational and information sciences, 3-6, 4-7  
 engineered processes and materials, 3-6, 4-7  
 microelectronics and photonics, 3-6, 4-7, 4-8  
 research furnace, 6-5  
 Resource Conservation and Recovery Act, 7-37, 7-39, 11-2, 11-7  
 risk assessment, 5-36, 5-38, 5-39, 5-42, 5-55, 5-56, 5-57, 5-59,  
 7-3, 7-15, 7-18, 7-32, 7-38, 7-65, 7-68, 11-5  
 risk management, 4-10, 5-57, 7-27, 11-2, 11-6, 11-8, 12-2,  
 12-3  
 road maps, 1-2, 5-16, 5-18, 5-19, 5-21, 5-51, 6-2, 6-4  
 roadside sensors, 5-35, 5-36  
 robotics, 3-8, 5-3, 5-5, 5-6, 5-7, 5-17, 5-20, 5-38, 5-39, 5-43,  
 5-46, 5-48, 5-57, 6-7, 7-6, 7-12, 7-19, 7-22, 7-23, 7-32,  
 7-58, 7-62, 9-8, 9-11, 9-12

## S

Safe and Secure Dismantlement Working Group, 5-58  
 Safe Secure Transport Program, 5-36  
 Safeguards and Security (SAS) Program, 7-7, 7-8, 12-1, 12-2, 12-3  
 SafeGuards Transporter, 5-55, 7-18  
 safety assessment, 7-6, 7-29, 7-64, 7-65, 11-4, 11-6, 11-8  
 Safety Technology and Engineering Program, 7-14  
 Sandia Advanced Rapid Manufacturing Proposal Team, 5-10  
 Sandia Condition Assessment Survey, 9-6  
 Sandia President's Quality Award, 3-4  
 Santa Teresa Intermodal Facility, 5-35, 7-66  
 Saturn x-ray simulator, 3-7, 3-8, 7-19, 7-21, 7-27, 7-63  
 SCB Incorporated, 6-10  
 Science and Mathematics Education Outreach Program, 7-53, 7-56  
 Science and Technology Programs, 7-45, 7-46, 13-6, 13-8  
 scientific and technical information management, 10-6  
 Scientifically Tailored Materials Program, 7-48  
 Sea-Launched Strategic Systems Phase 2 study, 7-12  
 sectors  
 goals, 3-4  
 management of, 3-3, 4-10  
 program, 3-3, 5-30  
 Security, Facilities, and ES&H Center, 11-4  
 security management, 12-1  
 seismic technology, 7-35  
 SEMATECH consortium, 3-6, 5-16, 5-19, 5-21, 6-5, 6-6, 6-8,  
 6-11, 7-27  
 Semiconductor Equipment Technology Center, 5-16, 6-5, 6-6,  
 6-8, 7-27  
 Semiconductor Industry Association, 5-16, 5-18, 5-19, 5-21,  
 6-2, 6-5  
 semiconductors, 3-6, 3-8, 5-10, 5-16, 5-18, 5-19, 5-21, 5-22,  
 5-26, 5-42, 6-2, 6-4, 6-5, 6-6, 6-7, 6-8, 6-10, 7-8, 7-9,  
 7-22, 7-24, 7-27, 7-31, 7-32, 7-41, 7-42, 7-48, 7-49, 7-67  
 Sensor Test and Modeling Laboratory, 5-17  
 sensors, 4-5, 5-5, 5-6, 5-7, 5-10, 5-11, 5-16, 5-17, 5-20, 5-22,

5-23, 5-25, 5-35, 5-36, 5-38, 5-39, 5-40, 5-41, 5-45,  
 5-47, 5-48, 5-52, 5-53, 5-54, 5-55, 6-4, 6-6, 6-7, 6-8,  
 6-10, 6-11, 7-7, 7-8, 7-9, 7-13, 7-14, 7-15, 7-16, 7-22,  
 7-23, 7-26, 7-34, 7-36, 7-42, 7-60, 7-64, 7-66, 7-67,  
 7-68, 12-2  
 Severe Accident Research Program, 7-65  
 severe environment test facilities, 6-4, 7-8  
 SI Logic, 6-11  
 signal processing, 5-22, 5-24, 5-26, 5-55, 7-23  
 Signetics, 6-11  
 site modernization projects, 9-10, 9-12  
 Small-Business Technology Transfer Program, 6-9  
 smart  
 bombs, 5-17, 5-22  
 highways, 5-35  
 materials, 5-5, 5-10, 5-11, 5-15  
 structures, 5-10, 7-64  
 substrates, 5-21  
 systems, 5-19  
 weapons, 4-5  
 SMARTWELD program, 6-7  
 software  
 advanced information technology, 5-26  
 complementary programs, 5-17  
 development, 5-30  
 for electronics, 5-18  
 emissive flat-panel displays, 5-20  
 engineering, 7-47  
 and information surety, 5-28  
 integrated, 5-17  
 mesh generation, 6-3, 6-10, 7-23  
 for mixed media data, 5-31  
 parallel computing, 7-23  
 polymer alloys design, 6-11  
 prototypes, 5-7  
 techniques, 5-6  
 technology transfer, 6-2, 6-3  
 tools, 5-30  
 verification, 5-17, 7-26  
 wafer-level, 6-10  
 Solar One, 7-41  
 Solar Thermal Program, 5-38, 7-40  
 solar thermal systems, 3-8, 5-46, 6-8, 7-40, 7-41, 13-13  
 Solar Two, 5-42, 7-41  
 space nuclear power systems, 7-63  
 Specialty Metals Processing Consortium, 3-6, 6-5, 7-25  
 SPR-III fast pulse reactor, 7-21  
 Stage Right Project, 7-12, 7-32  
 STARBASE system, 5-36  
 START II agreement, 4-3, 7-32  
 START-mandated nuclear weapon dismantlement, 3-8  
 stockpile  
 concurrent engineering practices, 5-13  
 control of, 5-57  
 design and production capability, 7-28  
 drawdown and disposition of, 4-2, 4-5, 7-1, 7-9, 7-12, 7-32,  
 7-35  
 engineering development projects, 7-12, 7-14  
 environmentally conscious manufacturing, 7-34  
 evaluation program, 3-5, 3-9, 7-10, 7-12, 7-30  
 gas boosting systems, 7-16  
 improvement programs, 7-14, 7-16, 7-20  
 inspection of, 7-3  
 instrumentation, 7-13

limits on, 4-3  
 management, 5-13, 7-2, 7-8, 7-9, 7-10, 7-28  
 radiation effects, 7-21  
 readiness, 5-57, 7-11  
 real-time monitoring, 5-22  
 reliability, 3-5, 7-5, 7-11, 7-30  
 retrofits, 5-5, 7-10, 7-13  
 safety, 7-29  
 sensor applications for, 5-22  
 stewardship of, 3-2, 4-5, 4-9, 7-2, 7-4, 7-5, 7-8, 7-9, 7-10, 7-12, 7-15, 7-16, 7-22, 7-28, 7-29, 7-32, 7-35  
 support, 4-9, 7-4, 7-8, 7-10, 7-28, 7-29, 7-30, 7-32, 13-9  
 surety, 5-56, 7-11, 7-14, 7-16, 7-28, 7-29  
 surveillance, 7-2, 7-10, 7-16, 7-22, 7-30, 7-31  
 technology, 7-16  
 tracking and inventory, 4-5  
 use-control, 5-55, 5-56, 7-1, 7-16  
 strained-layer-superlattices, 5-16, 5-22, 7-9, 7-49, 7-67  
 Strategic Arms Reduction Treaty, 5-53, 7-32  
 Strategic Environmental Research and Development Program, 5-40, 5-41  
 Strategic Investment Criteria, 7-3  
 Strategic Petroleum Reserve, 7-43, 7-44, 7-45, 13-16  
 Strategic Plan, 1-1, 3-4, 4-1, 4-2, 4-9, 4-10  
 Strategic Staffing Forum, 8-2  
 strategic thrusts, 4-7, 4-8. *See also* integrated capabilities  
   advanced information technology, 1-2, 4-4  
   advanced manufacturing, 1-2, 4-4  
   electronics technology, 1-2, 4-4  
   pulsed power technology, 4-4  
 submarine-launched ballistic missiles, 7-61  
 supercomputers, 3-8, 5-27, 5-28, 5-31, 5-36, 5-37, 7-54, 10-2, 10-4  
 superconductors, 7-48  
 surety  
   communications and computing, 5-29  
   information, 3-6, 5-3, 5-28, 5-30, 5-33, 5-52, 7-36  
   of nuclear weapons, 7-2, 4-3, 5-17, 7-1, 7-9, 7-14, 7-28  
   soft spots, 7-12  
   stockpile, 5-56, 5-57, 7-9, 7-11, 7-14, 7-17, 7-28, 7-29  
   strategic, 4-5, 7-2, 7-4  
   technology, 7-17, 7-18, 7-68  
   transportation, 5-55, 5-59, 7-4, 7-18  
   weapon, 5-56, 5-57, 7-9, 7-10, 7-14, 7-15, 7-16  
 Synthesis and Processing Center, 7-50  
 synthetic aperture radar, 5-21, 5-22, 7-7, 7-34  
 systems engineering science and technology, 7-6, 7-7

## T

Tactical Air Command and Control Facility, 5-55  
 teacher training and curriculum development, 7-55  
 technetium-99m, 5-48  
 technology  
   advanced, 5-4, 5-7, 5-10, 5-39, 5-51, 7-4  
   base, 3-7, 4-5, 4-6, 4-8, 5-2, 5-13, 5-22, 5-28, 5-47, 5-53, 6-8, 7-4, 7-7, 7-31, 7-32, 7-35, 7-46, 7-60, 7-65  
   deployment, 4-3, 4-8, 5-3, 5-4, 5-5, 6-3, 6-8, 6-9  
   development programs, 7-34  
   nuclear waste complex, 7-33  
   road maps, 5-19, 6-2  
   test beds, 5-22  
   transfer, 1-2, 3-5, 3-7, 3-9, 4-3, 4-5, 4-6, 4-7, 4-8, 4-9, 4-11, 5-2, 5-3, 5-4, 5-5, 5-7, 5-10, 5-12, 5-13, 5-16,

5-17, 5-18, 5-19, 5-20, 5-21, 5-23, 5-24, 5-28, 5-30, 5-31, 5-34, 5-36, 5-38, 5-42, 5-44, 5-45, 5-46, 5-47, 5-48, 5-51, 5-57, 5-58, 6-1, 6-2, 6-3, 6-4, 6-5, 6-7, 6-8, 6-9, 6-10, 7-3, 7-4, 7-7, 7-9, 7-16, 7-18, 7-19, 7-22, 7-23, 7-24, 7-25, 7-26, 7-33, 7-36, 7-38, 7-40, 7-41, 7-42, 7-43, 7-45, 7-46, 7-47, 7-49, 7-59, 7-60, 7-65, 7-66, 7-68, 8-6, 9-3, 9-4, 9-5, 9-10, 10-2, 12-2  
 Technology Assessment and Selection Panel, 5-3  
 Technology Information Environment for Industry (TIE-In), 5-31, 5-33, 6-9  
 Technology Support Center, 9-7, 9-12  
 test and experimental capabilities, 7-20  
 Test Ban Readiness initiative, 7-5  
 test beds  
   advanced industrial processes, 5-57  
   advanced manufacturing technology, 4-9, 7-33  
   cloud and radiation, 7-52  
   command and control, 7-15  
   fiber-optic and free-space interconnects, 5-22  
   information technologies, 5-31  
   linked workstations, 5-27  
 test simulation, 7-20  
 Testing and Evaluation Program, 7-29, 7-30  
 textile research, 6-4  
 thermal  
   analysis, 5-18, 5-21  
   cycling, 5-20  
   processing, 5-38  
   properties, 5-22  
   radiation, 5-16, 5-40  
   sciences, 3-6  
   spray technology, 5-45  
   testing, 5-17  
 thin films, 3-7, 5-17, 5-21, 6-5, 7-24, 7-26, 7-42, 7-49  
 Tokamak Physics Experiment, 7-46, 7-47  
 Tonopah Test Range, 3-10, 5-55, 9-1, 10-5, 11-3, 11-8  
 training, 3-4, 6-7, 7-11, 7-19, 7-29, 8-3, 8-4, 11-2, 11-5, 11-6  
 trajectory-sensing signal generator, 7-16  
 transportation, 4-1, 4-3, 5-34  
   applications, 5-35  
   energy technology, 5-1, 5-34, 5-37  
   of hazardous materials, 5-39, 5-41, 7-8, 7-16, 7-18, 7-29, 7-34, 7-35, 7-36, 7-37, 7-38, 7-39, 7-42, 7-43, 7-62, 7-66, 9-9  
   initiatives, 5-22, 5-35, 5-36  
   nuclear weapons, 7-10, 7-12, 7-28, 7-29, 7-31, 7-32, 7-63  
   of radioactive materials, 7-20, 7-39, 5-38, 7-62, 7-65  
   safeguards system, 5-55  
   safety, 4-5, 7-18  
   sector, 7-42, 13-13  
   of special materials in the former Soviet Union, 5-34  
   surety, 5-55, 5-59, 7-4, 7-18  
 Transportation Technology Center, 7-43  
 tritium, 7-8, 7-16, 7-20, 7-31, 7-46  
 Tritium Research Laboratory, 11-8  
 Tuition Assistance Program, 8-4

**U**  
 Ukraine, 6-5  
 ultra-miniature mechanical structures, 5-23  
 ultra-reliability in electronic components, 5-16  
 United Kingdom Atomic Weapons Establishment, 7-19  
 United Nations General Assembly, 5-53

unmanned aerospace vehicles, 5-40, 5-41, 7-46, 7-52, 7-53, 7-58  
unprocessed spent fuel, 5-39  
US Advanced Battery Consortium, 5-35, 6-4, 7-42  
US Council for Automotive Research, 3-6, 5-35, 5-36, 5-37  
US Global Climate Change Research Program, 5-40  
Utility-Scale Joint Venture Program, 5-46

## V

vapor deposition crystal growth, 5-17  
Verification and Control Technologies Program, 7-34  
virtual factories, 5-3, 5-57, 7-33  
virtual reality, 5-7, 5-8, 5-9, 5-10, 5-13, 5-26, 5-28, 5-29, 7-54  
visitor access, 3-9, 4-9, 9-4, 9-5, 9-6, 9-9, 12-2, 12-3  
voice communications, 10-4, 10-5

## W

### waste

characterization of samples, 5-38  
defense, 7-4, 7-36, 7-39  
from drilling activities, 7-68  
electronic components disposal, 7-36  
emplacement, 7-42, 7-43  
energy conservation program, 7-59  
hazardous, 4-1, 5-26, 5-38, 5-39, 7-4, 7-32, 7-36, 7-37, 7-39, 7-41, 7-51, 7-52, 7-59, 7-68, 9-9, 11-4, 11-5, 11-7  
management, 3-2, 4-6, 5-38, 5-41, 5-48, 7-2, 7-3, 7-4, 7-36, 7-37, 7-39, 7-59, 7-65, 9-11, 11-2, 11-4, 11-5, 11-7  
minimization, 5-13, 5-38, 5-47, 5-48, 7-2, 7-23, 7-36, 7-42, 7-68, 11-4, 11-6  
mixed, 11-7, 11-8  
nuclear, 3-5, 4-3, 4-6, 7-2, 7-7, 7-19, 7-38, 7-39, 7-51  
packages, 5-39, 7-43  
processing, 6-6  
radioactive, 3-8, 4-6, 5-38, 5-45, 5-48, 7-37, 7-39, 7-42, 7-65, 11-7  
reduction, 3-2, 5-4, 5-12, 6-7, 7-42, 7-59  
special-case, 7-39  
stabilization, 5-39  
transuranic, 7-38, 7-39  
Waste Isolation Pilot Plant, 3-5, 3-6, 5-38, 7-38, 11-5  
Waste Isolation Pilot Plant Land Withdrawal Act of 1992, 7-38  
Waste-Management Education and Research Consortium, 11-2  
weapon protection projects, 7-18  
weapon storage and security system (WS3), 7-18  
weapons. *See also* nuclear weapons  
advanced, 5-13, 5-22, 5-58  
design, 3-5, 5-3, 5-8, 5-13  
development program, 3-5, 7-9  
dismantlement. *See* dismantlement  
engineering development, 5-53  
evaluation test facility, 7-30  
inventory, 5-56  
of mass destruction, 3-7, 4-1, 4-3, 4-5, 4-7, 4-8, 5-53, 5-54, 7-1, 7-7, 7-12, 7-18, 7-34, 7-36  
physics, 5-58, 7-21, 7-27, 9-10  
programs, 4-1, 4-8, 7-1, 7-60  
quality, 7-29, 7-30  
realization, 5-57  
refresher training, 7-29  
research, 5-5, 7-9  
retirement schedules, 7-12, 7-32  
safety of, 7-14, 7-19

security, 7-16  
surety, 5-22, 5-56, 5-57, 7-9, 7-10, 7-14, 7-15, 7-16  
system analysis, 7-63  
testing, 5-53, 7-30  
transportation of, 7-7, 7-16, 7-18  
virtual prototyping of, 5-10  
welding, 4-8, 5-2, 6-7, 6-11, 7-9, 7-17, 7-22  
wind turbine technologies, 5-46, 5-50, 7-41  
wireless communications, 5-22, 5-32, 5-33  
work-for-others, 3-2, 3-5, 4-6, 5-21, 5-29, 7-59, 7-60, 7-69, 13-3, 13-6, 13-8, 13-20, 13-21

## X

x-ray sources, 3-7, 4-8, 7-21, 7-27, 7-62  
x-ray testing, 5-58, 7-20, 7-21, 7-66

## Y

Yucca Mountain Site Characterization Project, 3-5, 7-42, 7-43

This report was prepared as an account of work sponsored by an agency of the United States Government. Neither the United States Government nor any agency thereof, nor any of their employees, makes any warranty, express or implied, or assumes any legal liability or responsibility for the accuracy, completeness, or usefulness of any information, apparatus, product, or process disclosed, or represents that its use would not infringe privately owned rights. Reference herein to any specific commercial product, process, or service by trade name, trademark, manufacturer, or otherwise, does not necessarily constitute or imply its endorsement, recommendation, or favoring by the United States Government or any agency thereof. The views and opinions expressed herein do not necessarily state or reflect those of the United States Government or any agency thereof.

This work was performed at Sandia National Laboratories for the US Department of Energy under contract DE-AC04-94AL85000.