

SANDIA REPORT

SAND97-0029 • UC-606

Unlimited Release

Printed January 1997

Quartz Crystal Microbalance (QCM) Arrays for Solution Analysis

RECEIVED

JAN 17 1997

OSTI

Thomas W. Schneider, Gregory C. Frye, Stephen J. Martin,
Richard J. Kottenstette, Gordon C. Osbourn, John W. Bartholomew,
Loriann Weisenbach, Teresa V. Bohuszewicz, Daniel H. Doughty

Prepared by
Sandia National Laboratories
Albuquerque, New Mexico 87185 and Livermore, California 94550
for the United States Department of Energy
under Contract DE-AC04-94AL85000

Approved for public release; distribution is unlimited.

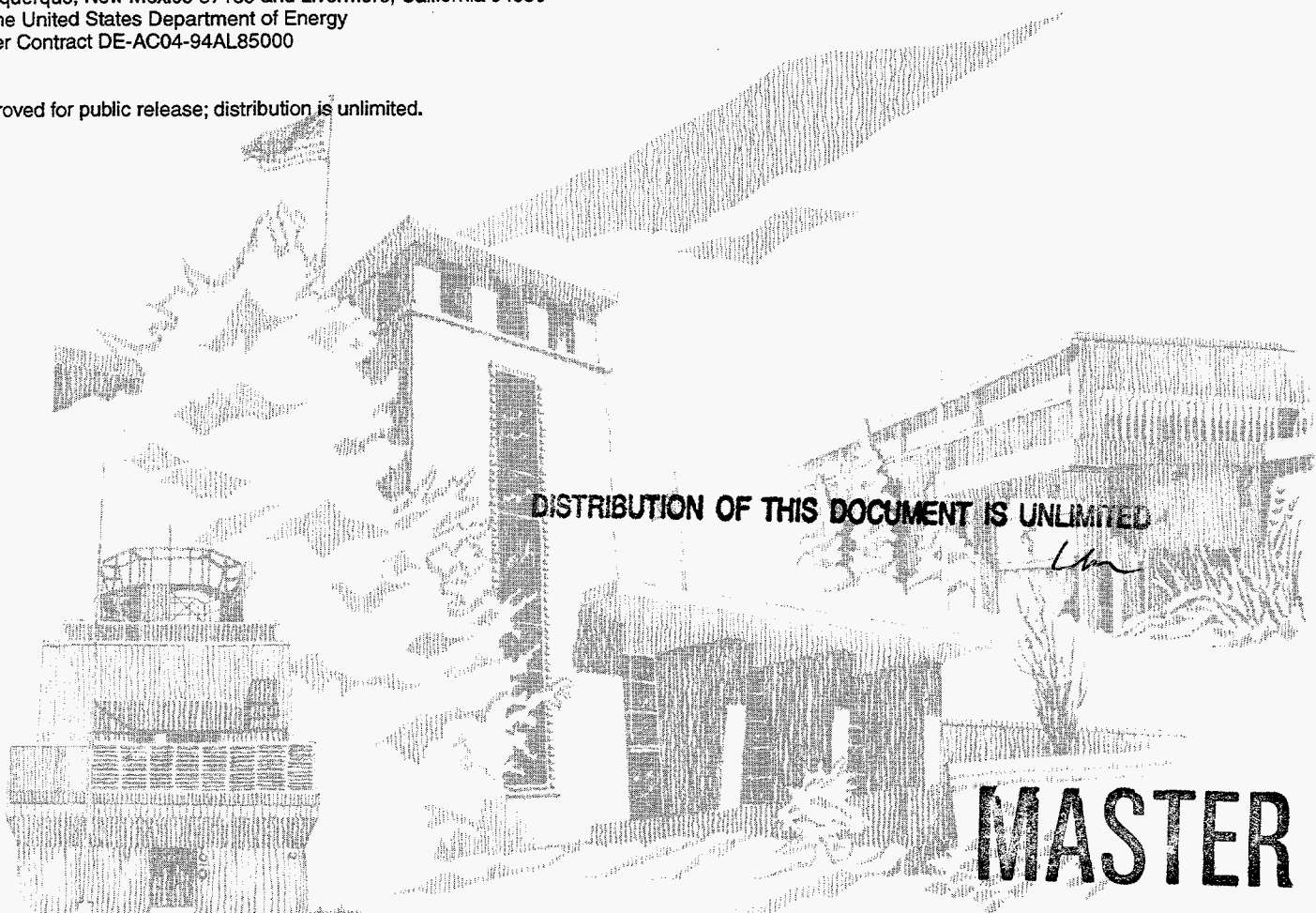

DISTRIBUTION OF THIS DOCUMENT IS UNLIMITED

Ulan

MASTER

Issued by Sandia National Laboratories, operated for the United States Department of Energy by Sandia Corporation.

NOTICE: This report was prepared as an account of work sponsored by an agency of the United States Government. Neither the United States Government nor any agency thereof, nor any of their employees, nor any of their contractors, subcontractors, or their employees, makes any warranty, express or implied, or assumes any legal liability or responsibility for the accuracy, completeness, or usefulness of any information, apparatus, product, or process disclosed, or represents that its use would not infringe privately owned rights. Reference herein to any specific commercial product, process, or service by trade name, trademark, manufacturer, or otherwise, does not necessarily constitute or imply its endorsement, recommendation, or favoring by the United States Government, any agency thereof or any of their contractors or subcontractors. The views and opinions expressed herein do not necessarily state or reflect those of the United States Government, any agency thereof or any of their contractors.

Printed in the United States of America. This report has been reproduced directly from the best available copy.

Available to DOE and DOE contractors from
Office of Scientific and Technical Information
PO Box 62
Oak Ridge, TN 37831

Prices available from (615) 576-8401, FTS 626-8401

Available to the public from
National Technical Information Service
US Department of Commerce
5285 Port Royal Rd
Springfield, VA 22161

NTIS price codes
Printed copy: A03
Microfiche copy: A01

DISCLAIMER

Portions of this document may be illegible in electronic image products. Images are produced from the best available original document.

SA97-0029
Unlimited Release
Printed January 1997

Distribution
Category UC-606

Quartz Crystal Microbalance (QCM) Arrays for Solution Analysis

Thomas W. Schneider[†], Gregory C. Frye, Stephen J. Martin, Richard J. Kottenstette
Microsensor Research and Development Department

Gordon C. Osbourn, John W. Bartholomew
Vision Science, Pattern Recognition, and Multisensor Algorithms Department

Loriann Weisenbach*, Teresa V. Bohuszewicz
Direct Fabrication Department

Daniel H. Doughty
Battery Programs Department

Sandia National Laboratories
Albuquerque, NM 87185-1425

Abstract

Quartz crystal microbalances (QCMs) are piezoelectric thickness-shear-mode resonators where the resonant frequency has long been known to vary linearly with the mass of rigid layers on the surface when the device is in contact with air. This reports summarizes the results from a Laboratory Directed Research and Development effort to use an array of QCMs to measure and identify volatile organic compounds (VOCs) in water solutions. A total of nine polymer-coated QCMs were tested with varying concentrations of twelve VOCs while frequency and damping voltage were measured. Results from these experiments were analyzed using a Sandia-developed pattern recognition technique called visually empirical region of influence (VERI) developed at Sandia. The VERI analyses of data with up to 16% and 50% sensitivity drifts were carried out on an array with six signals obtained from five sensors. The results indicate that better than 98% and 88% correct chemical recognition is maintained for the 16% and 50% drifts, respectively. These results indicate a good degree of robustness for these sensor films.

[†]Currently at Science Applications International Corporation. 1710 Goodridge Drive, McLean, Virginia 22102

*No longer at Sandia

Background

The original LDRD proposal described the "nature of the work" to be performed as: *This research will be directed toward discriminating and quantifying the concentration of individual chemical contaminants in liquid waste streams. The work will develop the hardware required to operate arrays of quartz crystal microbalances (QCMs), sensitized with chemically sensitive films, combined with pattern recognition software to interpret the array response. When fully calibrated, this system should provide real-time analyses of multicomponent solutions. Applications depend on the type of coatings developed; we intend to target dissolved species in water (both VOCs and ionic species).*

The following report summarizes our efforts in this LDRD project. Additional data and information can be obtained by further reading of the literature publications that were, at least in part, supported by this project. The information contained in these sources documents that this project successfully met our goals and objectives as well as serving to generate (to date) two new projects. The budget of these projects is at least as large as the investments made by the LDRD program.

Introduction

The large number of chemically-contaminated sites and the high cost for restoration present the need for economical, low power, sensitive and specific chemical sensors. Applications for these

sensors are often centered around detection of contaminants in water, for example, monitoring of contamination in groundwater and in process, recycle, and waste streams. Quartz crystal microbalances (QCMs) are well suited for these applications since they are rugged, low power, and easily miniaturized. Moreover, QCMs can be adapted for many different uses by developing coatings that respond to different target molecules, adding to their versatility.

QCMs are piezoelectric thickness-shear-mode resonators where the resonant frequency has long been known to vary linearly with the mass of rigid layers on the surface when the device is in contact with air [1]. More recently, these devices were also determined to be sensitive to changes in mass in contact with liquids [2,3]. Besides mass loading, changes in liquid density and viscosity can also affect QCM response [4-8]. These effects are important since liquid properties may change slightly as an analyte spike passes a device. However, at low analyte concentrations, very small changes in liquid physical properties generally occur. This can be verified by a lack of any detectable changes with an uncoated reference QCM.

Developments in QCM sensor technology have progressed in the area of gas phase analysis since the first report in 1964, where King used a QCM as a gas chromatograph sorption detector [9]. Since then, reports of other detection schemes for different gas phase analytes have appeared in the literature [10]. These reports describe the use of a variety of coatings with chemically-selective sorption properties for detection of target analytes.

Chemical recognition using selective coatings on QCMs has been explored to a much smaller extent for liquid-phase sensing than for gas-phase sensing. Very few cases of chemically-selective coated QCMs for liquid phase detection have been reported. Lasky and Buttry developed a glucose sensor by immobilizing hexokinase in a poly(acrylamide) matrix onto the surface of the QCM [11]. Cox et al. immobilized high-surface-area silica particles derivitized with metal specific ligands on the QCM to measure trace uranium in water [12]. Auge et al. used a cholesterol layer for detection of the surfactant N9 [13]. Despite these research efforts, an array of coated QCM sensors for liquid-phase sensing has not yet been reported. This study focused on using a QCM array for the detection of volatile organic compounds (VOCs) in water.

Chromatographic separations rely on the partitioning of chemicals from a mobile phase (either liquid or gas) into a chemically-selective stationary phase, in order to impart a separation. This same partitioning into a stationary phase is used to provide an increased concentration of an analyte on a sensor surface. Once the chemical has been concentrated, an increase in the sensitivity (or decrease in the minimum detection level) of a sensor can be realized.

Many new highly selective coatings amenable for piezoelectric transducers in liquid media have been developed. Coatings such as cyclodextrins, cavitands, and calixarenes have shown potential for making sensors selective for certain compounds or classes of compounds. An alternative and more versatile approach is to use an array of devices coated with different coatings that have only partial selectivity and respond in some way to all compounds. The pattern of responses from this sensor array can be analyzed using chemometrics or pattern recognition techniques to identify the

chemical being detected and determine its concentration [14]. In this study, a new pattern recognition technique, capable of handling nonlinear and even non-monotonic responses, was applied to the data [15,16].

Experimental

Quartz Crystal Microbalance - The AT-cut quartz crystals used in this study were purchased from Maxtec (Torrance CA) having a diameter of 25.4 mm and a thickness of 0.33 mm. They were patterned with two concentric gold-on-chrome electrodes having a wrap around geometry that allows both ground and radio frequency (rf) connections to be made to one side. The larger 12.9 mm electrode, used to contact the fluid, functioned as the ground electrode. The smaller 6.6 mm electrode on the opposing side was used to provide the rf signal. The different electrode sizes were used to minimize electrical fringing fields that may potentially arise between the electrodes through the crystal. Application of a voltage to the two electrodes produces a strain in the surface of the QCM along the cut of the crystal. An oscillator circuit providing an alternating voltage will produce a nominal fundamental frequency of 5 MHz for this particular crystal diameter and thickness (see Figure 1).

Flow Cell and Oscillator - Figure 1 shows one of the four flow cells used in this study. This stainless steel flow cell housed the QCM between a nitrile o-ring on the liquid side and a polycarbonate (Lexan) spacer on the opposite side where electrical contacts were made via spring-loaded pogo pins. The oscillator board (which was attached to the cell with an SMB connector) provides two output signals, the peak series resonance frequency and a voltage

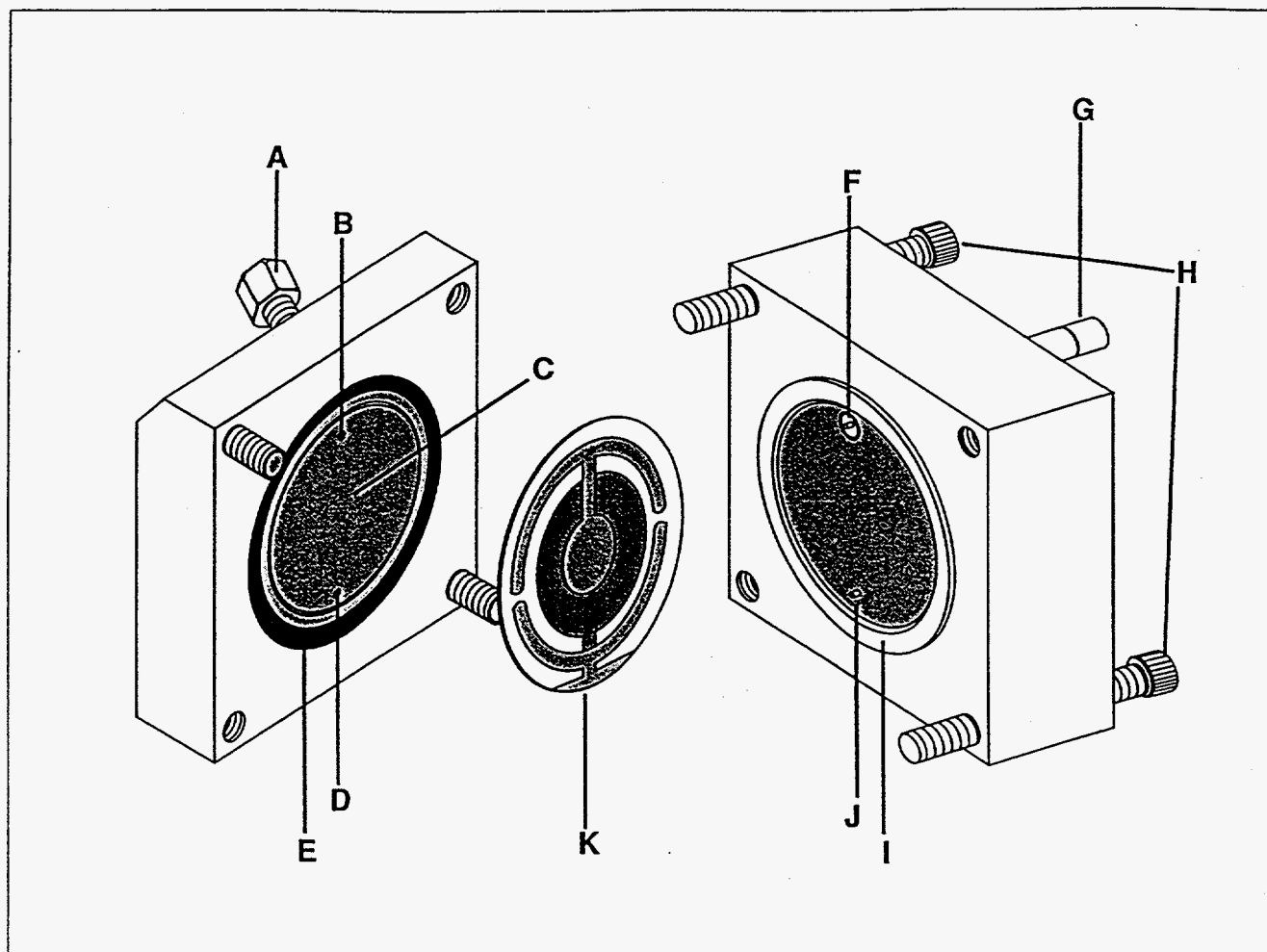

Figure 1. QCM liquid flow cell. (A) Zero dead volume tube connector. (B) Liquid exit port. (C) Liquid cavity. (D) Liquid inlet port. (E) O-ring. (F) Pogo pin rf-contact. (G) SMB rf-connector. (H) Socket Head Cap Screws. (I) Polycarbonate spacer. (J) Pogo pin ground contact. (K) QCM.

proportional to the resonance magnitude (indicates wave damping) [17].

Gas bubble trapping in the QCM cell or directly on the surface of the QCM has been found to interfere with QCM measurements, however, degassing of the test solutions was not done due to possible changes in concentration of the stock solutions by sparging of the VOCs. To minimize the problem of gas bubble trapping, the flow cells were constructed so that the liquid cavity created from the sealed QCM was positioned in a vertical direction in order to force gas bubbles through the cell. In addition, the liquid flow cell was designed to aid in bubble removal by setting the liquid outlet port at a 45 degree angle up from the surface of the QCM. This design provided a smooth flow of fluid across the QCM surface, sweeping gas bubbles through the cell without trapping them.

Compressional wave effects arising due to the unequal surface displacement of the QCM have recently been identified as a possible source of error for liquid sensing experiments [18-20]. The thickness of the polycarbonate spacer was adjusted to try to tune the thickness of the liquid cavity to a midpoint between compressional resonances, thus minimizing this effect. Since the compressional wavelength is affected by changes in the liquid density, the temperature was kept constant. At the low concentrations used in this study, changes in density of the solutions relative to that of pure water are not significant enough to affect the resonance condition.

Test System - The experimental setup consisted of an Eldex Model 9600 programmable pump for dilution, mixing and delivery of test solutions to the sensors. A Hewlett-Packard (HP) 3488A

Switch/Control Unit was used to switch between two HP 5384A Frequency Counters and an HP 3457A Multimeter. The multimeter had the ability to read 9 voltages; 3 voltages from the Eldex supplied the concentration profile and one voltage from each oscillator circuit provided the damping voltage measurement related to the energy loss of the QCM. The instrumentation was computer controlled with a program written in HP-Instrument Basic.

Coatings - Table 1 shows the polymers and films used for the QCM array. The coating procedure was optimized for each polymer by visual inspection for uniformity and reproducibility of the film. The standard procedure was to first spin coat the film onto the QCM surface and then heat the coated QCM in an oven to drive off remaining solvents. Two of the films, the Poly 3/15 Fox polyol and the Poly(isobutylene)-Carbosieve, required a surface derivatization step to keep the films from delaminating. An octadecane thiol (C18SH) self-assembled monolayer (SAM) was used in both cases to enhance adhesion of the film to the device surface.

Chemicals - The test matrix for these experiments consisted of three classes of organic chemicals: polar, nonpolar, and chlorinated. Four chemicals from each of these classes were tested. The polar compounds studied were acetone, isopropanol, ethylene glycol, and ethyl acetate. The nonpolar compounds used in this study were p-xylene, toluene, cyclohexane, and n-pentane. The chlorinated hydrocarbons were carbon tetrachloride, chloroform, trichloroethylene (TCE) and tetrachloroethylene (PCE). All chemicals were of certified grade or better and obtained from Fisher, excluding PCE which was 99.8% from Sigma-Aldrich.

Table 1. Polymers and Films for the QCM Arrays

Coating	Company	Coating Procedure	Solution
Poly(isobutylene)	Aldrich	2000 rpm for 30 s, 10 min. at 40°C	1% w/v in chloroform
Ethyl Cellulose	Aldrich	2000 rpm for 30 s, 10 min. at 45°C	1% w/v in 80% toluene and 20% ethanol
Poly(vinyl acetate)	Aldrich	2000 rpm for 30 s, 5 min. at 45°C	1% w/v in toluene
Poly 3/15-FOX polyol	Gencorp Aerojet	1000 rpm for 30 s, 5 min. at 100°C, C18SH SAM Coated	1% w/v in hot tetrahydrofuran (THF)
Poly(epichlorohydrin)	Scientific Polymer Products, Inc.	1000 rpm for 30 s, 5 min. at 100°C	2% w/v in methyl ethyl ketone (MEK)
Poly(isoprene), <i>trans</i>	Aldrich	10 drops at 1500 rpm for 60 s, 5 min. at 100°C	0.8% w/v in 50% cyclohexane, 50% chloroform
Poly(diphenoxy-phosphazene)	Scientific Polymer Products, Inc.	1500 rpm for 60 s, 5 min. at 100°C	5% w/v in chlorobenzene
Poly(isobutylene)-Carbosieve S-III	Aldrich Supelco	C18SH SAM coated surface, 1 drop of PIB solution, covered surface with Carbosieve	PIB 1% w/v in chloroform
OV-215	Ohio Valley Specialty Chemicals	10 drops at 1000 rpm for 90 s, 5 min. at 100°C	2% w/v in acetone

For the nonpolar and chlorinated groups, stock solutions were prepared by adding an excess of the chemical to a water bottle to prepare a saturated solution (the excess chemical maintained the solution at saturation). The ppm concentrations of the stock solutions were calculated by using

their solubility constants in water. For compounds in the polar group, which are less volatile and more likely to remain at a constant concentration for a reasonable time period, 1% by weight (10,000 ppm) stock solutions were prepared. Deionized water was used for both the stock solutions and the diluent stream.

Liquid Challenges - As shown in Figure 2, the experimental setup for exposing the QCMs to liquid challenges involved using four cells in series (as shown in Fig. 2, up to six are possible). The first cell in line always contained an uncoated QCM which provided a reference to changes in density or viscosity of the solution. The next three cells in the array housed polymer coated QCMs (Table 1). A typical run was started by pumping deionized (DI) water through the cells at a rate of 5 ml/min. A stable frequency and damping voltage response vs. time was first established for a 15 min. time interval. This DI water baseline was then followed by a series of 5 min. concentration challenges with solutions of various dilutions of stock bottles contaminated with known concentrations of a single VOC. These challenges were spaced by 15 min. intervening flows of DI water in order to allow the QCMs to reestablish stable baselines. The challenges were in order of increasing concentration (1, 5, 10, 25, and 50% of the stock solutions). Consequently, a concentration profile, as seen in Figures 3 and 4, was generated.

Results and Discussion

Description of Array Data: The oscillator board provided two different responses per sensor; a frequency and a damping voltage signal. The top half of Figure 3 shows the frequency response from a liquid challenge experiment as described in the Experimental Section. The right y-axis

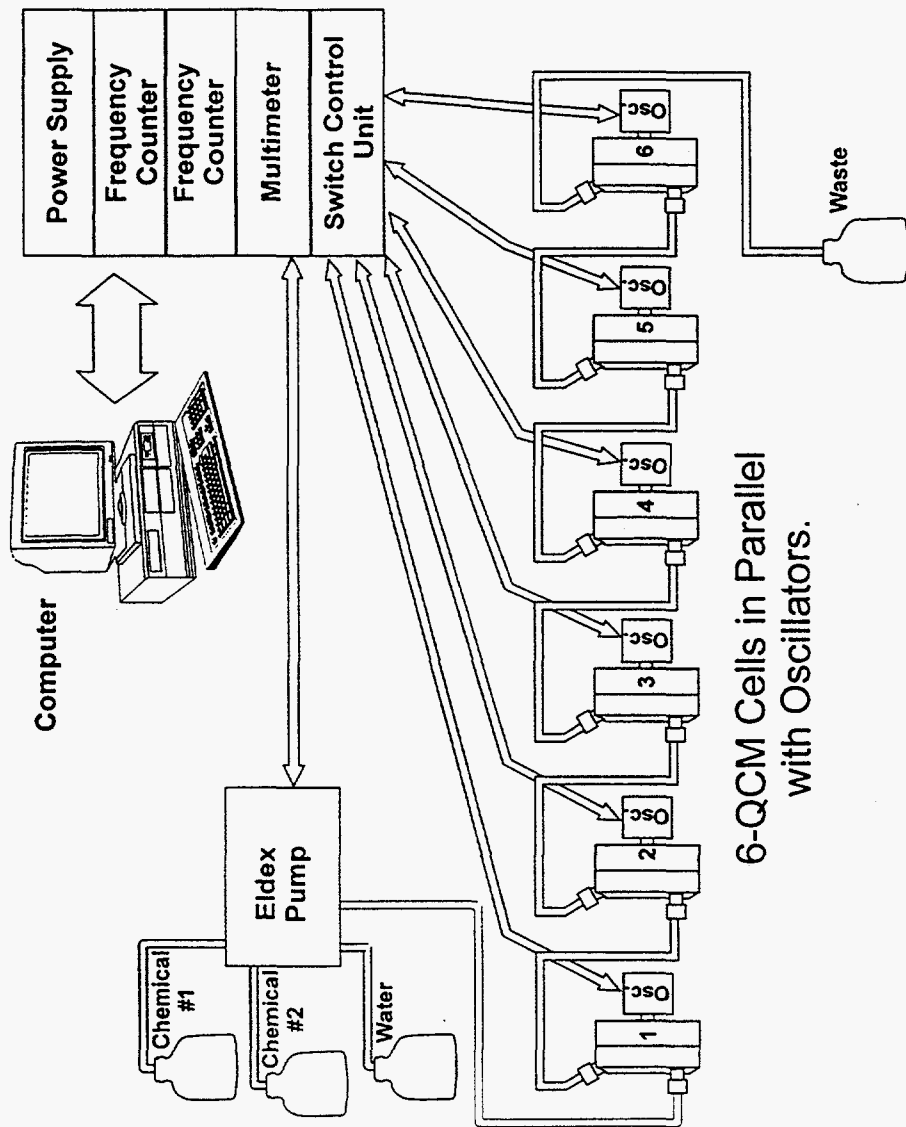

**6-QCM Cells in Parallel
with Oscillators.**

Figure 2. Experimental setup consisting of an Eldex HPLC Pump for delivery of chemical and water to up to six QCM cells, with attached oscillator boards, in series. A computer was used to control two frequency counters, a multimeter, and a switch control unit for data acquisition. The power supply provided 5 V DC to the oscillator boards.

gives the concentration profile for chloroform from 100 to 3200 ppm. The film coating for this QCM was poly(vinyl acetate) which responded rapidly and reproducibly to the chloroform. The negative frequency shifts corresponding to the concentration profile are the responses to the indicated concentrations of chloroform. These responses are typical for a film that is mass loaded (i.e., the mass of chemical appears as a negative shift in frequency with minimal changes in the damping voltage). A second response from the QCM, the damping voltage, is shown in the bottom half of Figure 3. In this case, this damping response is less pronounced than the frequency data and did not turn on until the third hit of chemical. At low concentrations, no response in either frequency or damping voltage was seen for the uncoated reference QCM, also shown in Figure 3. At higher concentrations, small responses in the frequency and damping voltage were detected in the reference QCM for this chemical. These changes, most likely related to the change in density and viscosity of the solution, were subtracted from the coated QCM response when calculating the total chemical response (see Fig. 5).

The top half of Figure 4 shows positive changes in frequency for the responses of various concentrations of TCE to a poly(diphenoxy phosphazene)-coated QCM. Several of the films responded with opposite frequency sign than that shown in Figure 3. Positive frequency changes can be explained by either of two effects: the modulus of the film was changing as a result of solvation from the chemical (softening or hardening) or film swelling occurred and the thickness of the film changed. The damping voltage is a good indicator of changes in the modulus or thickness as shown in the bottom part of Figure 4. The feed back element from the oscillator circuit has to apply significantly more voltage to maintain zero phase, indicating a significant

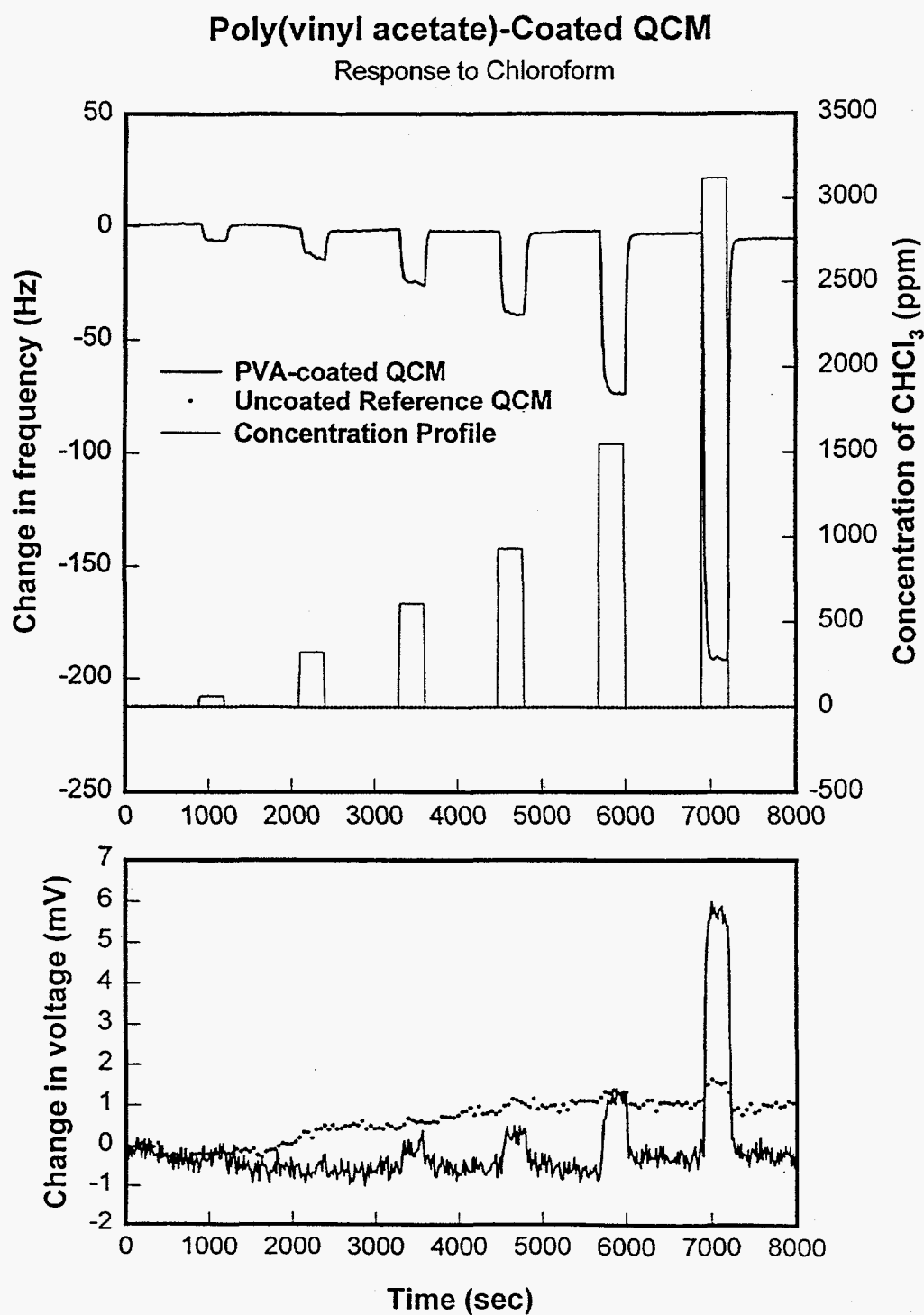

Figure 3. Top graph shows frequency response for a poly(vinyl acetate)-coated QCM (solid line) and an uncoated reference QCM (dotted line) to the indicated concentration profile of chloroform (dashed line). Bottom graph shows the damping voltage response.

Poly(diphenoxy phosphazene)-Coated QCM

Response to Trichloroethylene

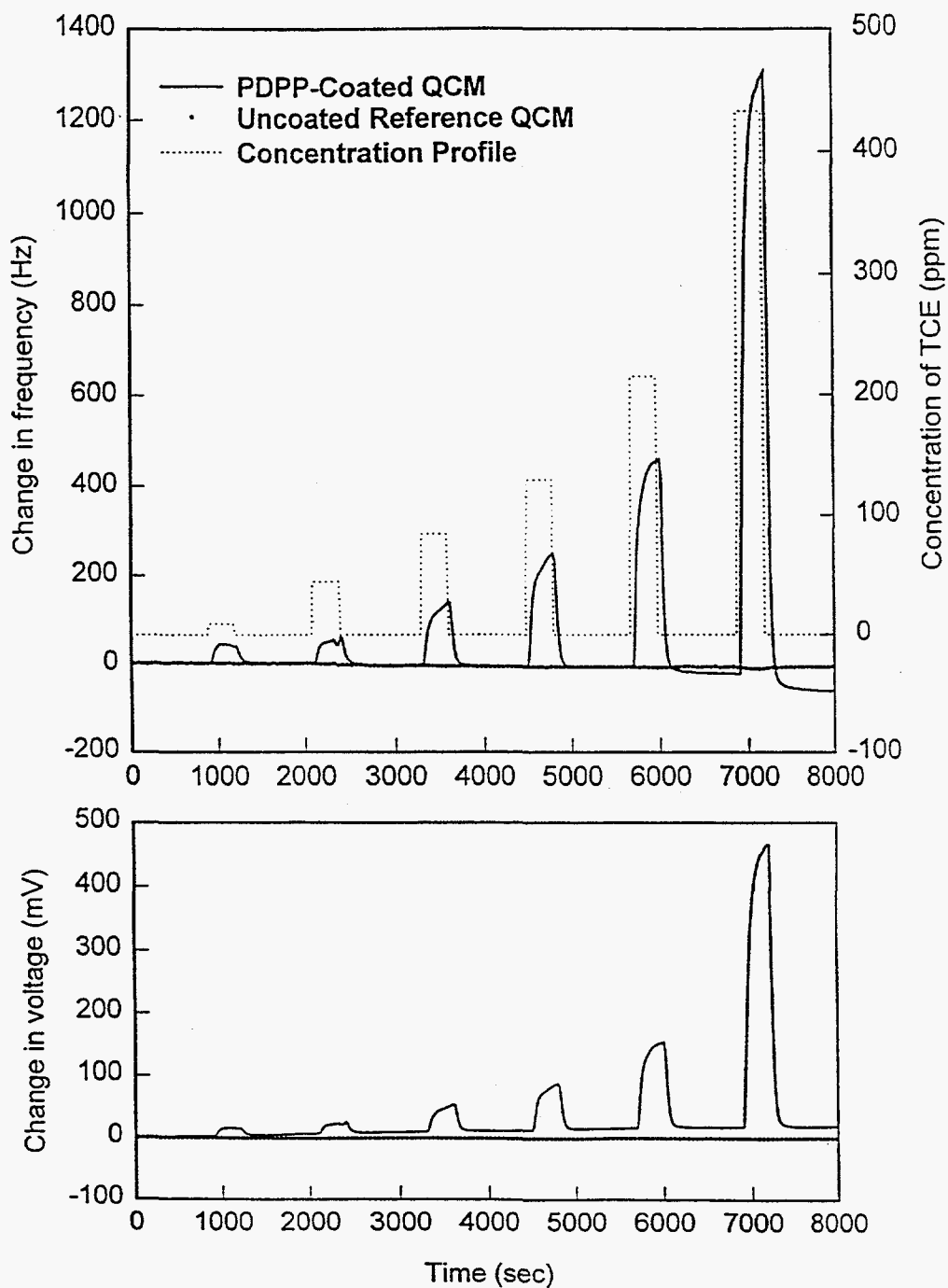

Figure 4. Top graph shows frequency response for a poly(diphenoxy phosphazene)-coated QCM (solid line) and an uncoated reference QCM (dotted line) to the indicated concentration profile of trichloroethylene (dashed line). Bottom graph shows the damping voltage response.

increase in device damping. This increase is inconsistent with rigid mass loading on the surface.

Pattern Recognition: Pattern recognition (PR) analysis has been carried out to: (1) identify the individual chemicals from the array responses and subsequently quantify the chemical concentrations, (2) determine which subsets of the 18 sensor signals provide the best chemical recognition performance, and (3) determine the robustness of chemical recognition with artificially added sensitivity drifts. A new PR method, called visually empirical region of influence (VERI), was used here [18,21,22]. VERI-PR was developed by one of the authors, and has proved useful for handling diverse PR problems in chemical sensing and multispectral image classification. VERI-PR exhibits several useful properties: the ability to handle complex sensor signals (nonlinear, nonmonotonic); PR results are determined entirely by the training data, i.e. no user-supplied threshold adjustments or computations are required; and bounded class volumes for each chemical class, so that unexpected chemicals (outside of the training set) are typically classified as unknown rather than spuriously identified as one of the training set chemicals. VERI is also able to identify overlapping and touching class volumes automatically (i.e., chemicals which give similar array responses and are likely to be incorrectly identified by a PR analysis), and is thus useful for directly comparing the ability of different sensor combinations to distinguish the chemicals of interest.

Training data and test data for all chemicals were interpolated from a smooth spline fit to the raw sensor responses. Two types of noise were added back to the data: estimated measurement noise (3.0 Hz for the frequency signals and 0.3 mV for the attenuations signals) and artificial drift of

the sensor sensitivities to mimic long-term aging effects. Drift for each array response was produced by reducing the sensitivity of each sensor response from unity by an independent random factor in a specified range. The three sensitivity drift ranges were: no reduction, 0% to 16%, and 0% to 50%. Separate training data sets and test data sets were produced for each drift range. The drift results provide an indication of the robustness of the chemical recognition under extended use.

A "leave-one-out" analysis was carried out on the training data for all possible arrays made up of six or fewer sensors (twelve or fewer signals), so that the chemical recognition performance of all such arrays could be compared. Leave-one-out analyses provide the best use of the available training data while avoiding the bias associated with including the classification results of data points that are present in the training set. The VERI method is efficient enough that all of these arrays can be explicitly examined using SPARC workstation hardware. We prefer this more computationally intensive approach to the commonly-used principal components analysis (PCA). PCA computations provide useful qualitative insights and are often the best guidance for signal selection from among very large numbers of potential signal combinations, but they are not guaranteed to provide the best choice of signals for distinguishing classes [23]. The VERI leave-one-out results were obtained for training data with no sensitivity drift. The results (not shown) indicated that the best accuracy of the chemical recognition without added drift was in the high 80s for the best three signal arrays, in the mid-to-high 90s for the best four and five signal arrays, and in excess of 99% for the best arrays with six or more signals. Figure 5 illustrates the relatively good separation of the different chemical classes achievable using only

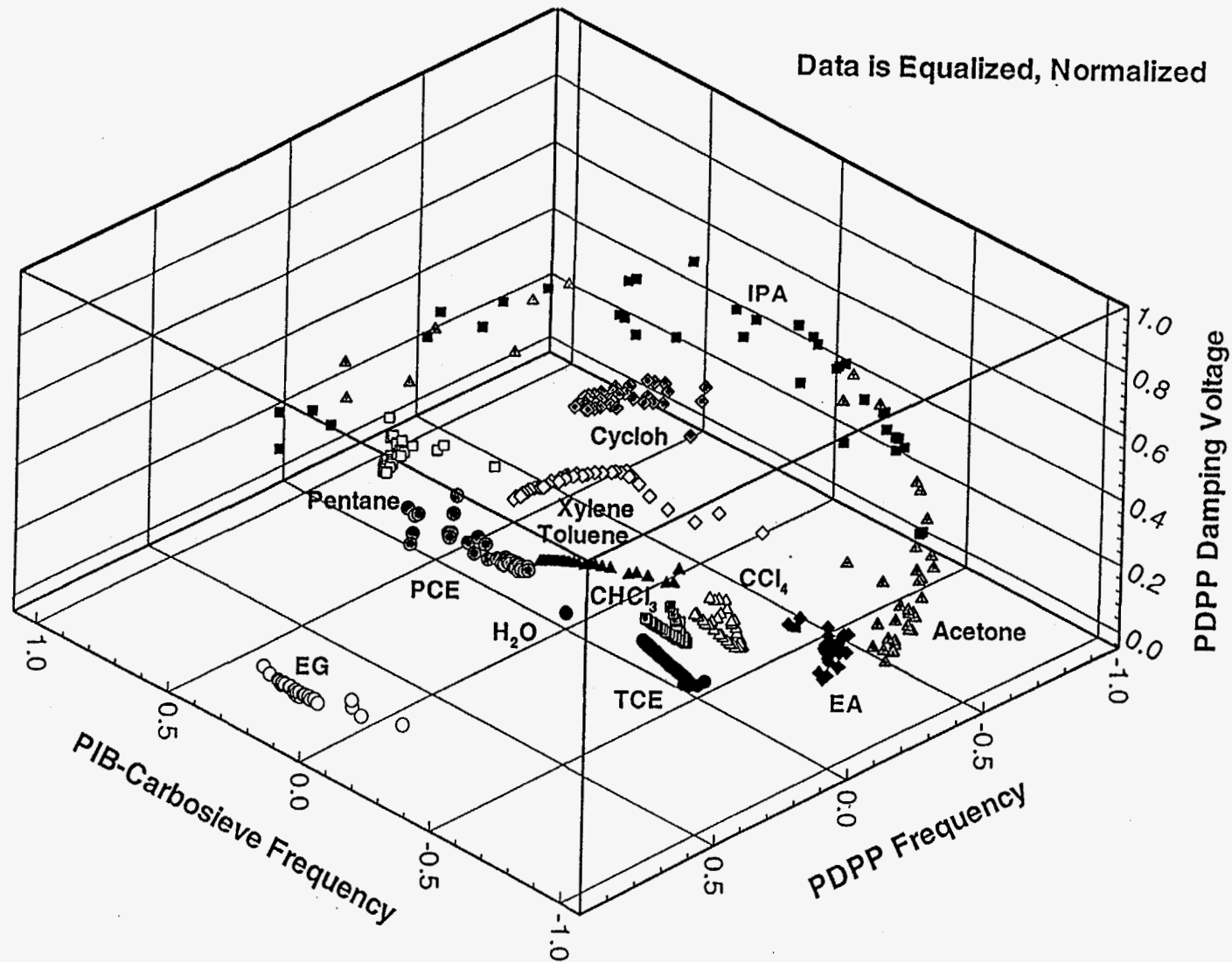

Figure 5. Representation of equalized and normalized data from two sensors (three total responses) showing clustering of data for each VOC and effective separation from other VOCs.

three sensor signals (the maximum number that can be effectively represented in two dimensions).

The PR analyses of data with up to 16% and 50% sensitivity drifts were carried out on an array with six signals obtained from five sensor films (polyvinyl acetate, PIB, FOX, epichlorohydrin, PDPP). The results indicate that better than 98% and 88% correct chemical recognition is maintained for the 16% and 50% drifts, respectively. These results indicate a good degree of robustness for these sensor films.

Acknowledgments

This work was performed at Sandia National Laboratories, supported by the United States Department of Energy under contract number DE-AC04-94AL85000. Sandia is a multiprogram laboratory operated by Sandia Corporation, a Lockheed Martin Company, for the United States Department of Energy. Sandia's Laboratory Directed Research and Development (LDRD) program provided funding for this work.

References

1. Sauerbrey, G. *Z. Phys.* **1959**, *155*, 206.
2. Konash, P.L.; Bastiaans, G.J. *Anal. Chem.* **1980**, *52*, 1929.
3. Nomura, T. *Anal. Chim. Acta* **1981**, *124*, 81.
4. Kanazawa, K.K.; Gordon, J.G., II *Anal. Chem.* **1985**, *57*, 1770-1771.
5. Josse, F.; Shana, Z.A.; Radtke, D.E.; Haworth, D.T. *IEEE Trans. Ultrason. Ferroelect. Freq. Contr.* **1990**, *37*(5), 359-368.
6. Martin, S.J.; Frye, G.C.; Wessendorf, K.O. *Sensors and Actuators A* **1994**, *44*, 209-218.
7. (a) Martin, S.J.; Granstaff, V.E.; Frye, G.C. *Anal. Chem.* **1991**, *63*, 2272-2281. (b) Granstaff, V.E.; Martin, S.J. US patent 5,201,215, 1993.
8. Auge, J.; Hauptmann, P.; Hartmann, J.; Rosler, S.; Lucklum, R. *Sensors and Actuators B*, **1995** *24-25*, 43-48.
9. King, W.H. *Anal. Chem.* **1964**, *36*(9), 1735-39.
10. (a) Karmarkar, K. H.; Guilbault, G.G. *Anal. Chim. Acta* **1974**, *10*, 237. (b) Janghorbani, M.; Freund, H. *Anal. Chem.* **1973**, *45*, 325. (c) Karmarkar, K.H.; Webber, L.M.; Guilbault, G.G. *Anal. Chim. Acta* **1976**, *81*, 265. (d) Karmarkar, K.H.; Guilbault, G.G. *Environ. Lett.* **1975**, *10*, 237. (e) Karasek, F.W.; Gibbins, K.R. *J. Chromatogr. Sci.*, **1974**, *89*, 31. (f) Karasek, F.W.; Tiernay, J.P. *J. Chromatogr.* **1974**, *89*, 31. (g) Edmonds, T.E.; West, T.S. *Anal. Chim. Acta.* **1980**, *117*, 147-157. (h) McCallum, J.J.; Fielden, P.R.; Volkan, M.; Alder, J.F. *Anal. Chim. Acta.* **1984**, *162*, 75-83. (i) Dalcanale, E.; Hartmann, J. *Sensors and Actuators B*, **1995**, *24-25*, 39-42. (j) Hierlemann, A.; Weimar, U.; Kraus, G.; Guaglitz, G.; Gopel, W. *Sensors and Materials* **1995**, *7*(3), 179-189. (k) Feldhiem, D.L.; Hendrickson, S.M.; Krejcek, M.; Elliott, C.M.; Foss, C.A. Jr. *J. Phys. Chem.* **1995**, *99*, 3288-3293.
11. Lasky, S.J.; Buttry, D.A., In "Chemical Sensors and Microinstrumentation", ACS Symposium Series No. 403, 237-246, Chap. 16; American Chemical Society: New York, 1989.
12. (a) Cox, R.; Gomez, D.; Buttry, D.A.; Bonnesen, P.; Raymond, K.N. In "Interfacial Design and Chemical Sensing" Mallouk, T.E.; Harrison, D.J., Eds.; ACS Symposium Series No 561, 71-77, Chap. 7; American Chemical Society: New York, 1994. (b) Cox, R.; Buttry, D.A.; Bonnesen, P.; Raymond, K.N. *Chemtech* **1994**, *24*, 18-21.

13. Auge, J.; Hauptmann, P.; Eichelbaum F.; Rosler, S. *Sensors and Actuators B*, **1994**, *18-19*, 518-522.
14. (a) Carey, W.P.; Beebe, K.R.; Sanchez, E.; Geladi, P.; Kowalski, B.R. *Sensors and Actuators*, **1986**, *9*, 223-234. (b) Carey, W.P.; Kowalski, B.R. *Anal. Chem.* **1986**, *58*, 3077-84.
15. Osbourn, G.C.; Bartholomew, J.W. In prep.
16. (a) Ricco, A.J.; Osbourn, G.C.; Bartholomew, J.W.; Crooks, R.M.; Xu, C.; Allred, R.E. *Technical Digest 1994 Solid-State Sensor and Actuator Workshop*, Transducer Research Foundation, Cleveland, **1994**, pp. 180-183. (b) Osbourn, G.C.; Bartholomew, J.W.; Frye, G.C.; Ricco, A.J. *Technical Digest 1994 Solid-State Sensor and Actuator Workshop*, Transducer Research Foundation, Cleveland, **1994**, pp. 193-196. (c) Ricco, A.J. *Interface*, **1994**, *3*, 38.
17. (a) Wessendorf, K.O. Proceedings 1993 IEEE Frequency Control Symp., IEEE, New York, pp. 711-717. (b) Martin, S.J.; Wessendorf, K.O.; Spates, J.J.; Huber, R.J. Abstracts of papers, 186th Meeting of the Electrochemical Society, Oct. 1994, Abstract 668.
18. Tessier, L.; Patat, F.; Schmitt, N.; Feuillard, G.; Thompson, M. *Anal. Chem.* **1994**, *66*, 3569-3574.
19. Lin, Z.; Ward, M.D. *Anal. Chem.* **1995**, *67*, 685-693.
20. Schneider, T.W.; Martin, S.J. *Anal. Chem.* **1995**, *67*, 3324-3335.
21. Osbourn, G.C. and Martinez, R. F., *Patt. Rec.* **1995**, *28(11)*, 1793-1806.
22. Osbourn, G.C.; Bartholomew, J.W.; Bouchard, A.M.; and Martinez, R.F., SAND Report (in preparation).
23. Nadler, M. And Smith, E., *Pattern Recognition Engineering*, Wiley, New York, 1993.

Distribution :

Sandia National Laboratories

MS1423	J. W. Bartholomew, 1155
MS1423	G. C. Osbourn, 1155
MS1425	G. C. Frye, 1315 (10)
MS1425	R. J. Kottenstette, 1425
MS0613	D. H. Doughty, 1521 (3)
MS1349	T. V. Bohuszewics, 1831
MS9018	Central Technical Files, 8940-2
MS0899	Technical Library, 4414 (5)
MS0619	Review and Approval Desk, 12630 (for DOE/OSTI) (2)
MS0161	Patent and Licensing Office, 11500 (3)