

current

CONF-9610167--1
SAND96-2032C

Production Planning Tools and Techniques for Agile Manufacturing

Edwin A. Kjeldgaard
Sandia National Laboratories, Albuquerque, NM 87185

Dean A. Jones
Parallax, Inc., Albuquerque, New Mexico 87112

George F. List
Rensselaer Polytechnic Institute, Troy, NY 12180

Mark A. Turnquist
Cornell University, Ithaca, NY 14853

RECEIVED

SEP 18 1996

OSTI

ABSTRACT

Effective use of resources which are shared among multiple products or processes is critical for agile manufacturing. This paper describes the development and implementation of a computerized model to support production planning in a complex manufacturing system at the Pantex Plant (a U. S. Department of Energy facility). The model integrates two different production processes (nuclear weapon dismantlement and stockpile evaluation) which use common facilities and personnel, and reflects the interactions of scheduling constraints, material flow constraints and resource availability. These two processes reflect characteristics of flow-shop and job-shop operations in a single facility. Operational results from using the model are also discussed.

KEYWORDS: Production planning, scheduling, optimization, agile manufacturing

INTRODUCTION

MASTER

Nagel and Bhargava (1994) define agile manufacturing as "the ability to thrive and prosper in a competitive environment of continuous improvement and unanticipated change, to respond quickly to rapidly changing markets driven by customer-based valuing of products and services." Although this definition is aimed primarily at private-sector for-profit companies, the definition also applies to manufacturing operations conducted for the U.S. government, particularly for the Department of Energy (DOE). The need to respond quickly to rapid (and often unanticipated) changes, and to provide products and services of high quality and value to the customer, are very much a part of these operations.

DISTRIBUTION OF THIS DOCUMENT IS UNLIMITED.

This work was supported by the United States Department of Energy under Contract DE-AC04-94AL85000

DISCLAIMER

**Portions of this document may be illegible
in electronic image products. Images are
produced from the best available original
document.**

Sandia National Laboratories has developed a computerized manufacturing optimization model called the *Pantex Process Model (PPM)*. Its primary function is to assist the Pantex plant, a DOE facility in Texas, in planning its production activities. In support of DOE's nuclear weapon dismantlement and stockpile surety programs, "Pantex" is engaged in a mixture of tasks that share common production facilities, personnel and storage areas. Because of this, the PPM has the ability to:

- simultaneously plan two fundamentally different types of production processes utilizing common facilities and personnel;
- optimize total production output;
- allocate technicians efficiently; and
- expedite recovery planning and option evaluation after a production disruption.

Although designed initially for specific application at Pantex, the PPM is also capable of supporting agile manufacturing operations more generally. It can address problems of flow shop and job shop planning where common resources are shared. In a flow shop many individual production units follow the same prespecified sequence of operations (like an assembly line, for example), and the focus of production planning is on overall throughput, line balancing, bottleneck identification, etc. In a job-shop environment, individual items are made to order, with varying sequences of operations and varying times for each operation. Morton and Penticco (1993) provide a thorough description of the differences in approaching production planning and scheduling for flow shops and job shops.

An agile manufacturer must be able to produce a wide variety of products, in differing volumes, and have the ability to adapt the production plan quickly. In many instances, this means having the ability to mix flow shop activities and job shop activities, where the same resources (e.g., facilities, workstations, trained workers) are shared. The PPM is designed for this environment, being able to optimize the total output from parallel production activities that use common resources.

PROBLEM DEFINITION

To maximize total production given the resource limitations of the plant is the problem to be solved. The workstations are combinations of facility types and personnel and the work performed is mostly manual, being either dismantlement (the disassembly of weapons) or evaluation tasks (work done in support of stockpile surety). Total production is in the thousands, the workstations number about 50, and the number of production technicians is in the hundreds.

Production planning is complex, for a number of reasons. One problem is that the disassembly and evaluation activities are fundamentally different. Disassembly resembles a flow-shop situation, with a network flow diagram like the one illustrated in Figure 1. At any given time, several different types of weapons are being dismantled, each with its own unique series of

operations. Evaluations require a unique sequence of operations on individual units (i.e., job-shop operation), and each unit typically has scheduling constraints (i.e., earliest available start times and latest allowable completion times). Evaluation tasks are significantly more complex and often involve situations where facilities are being “used” by partially disassembled units, but technicians are not involved. Both types of operations use common facilities and personnel.

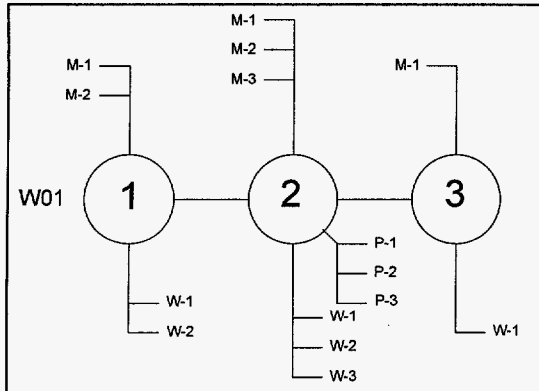

Figure 1: Example flow diagram of disassembly operations used by the PPM, where W01 = weapon system 1, W-1 = waste stream 1, M-1 = input material 1, P-1 = part 1, and the three nodes (numbered circles) indicate specific operations or processes.

More complexity arises from the extremely demanding and complicated safety and security rules. For example, technicians must receive extensive training before being certified for a particular task. The combination of several hundred technicians and nearly one hundred unique certifications presents a daunting assignment problem. Adding to this challenge is the fact that certifications must be used or they are lost, as determined by another set of complex rules.

A “two-person” rule must also be observed. At least two technicians (each with the same certification) be present during an operation.

Compliance with ALARA guidelines must also be addressed. Strict guidelines must be

followed to ensure that personnel receive radiation doses as low as reasonably attainable (ALARA), and if the maximum dose is reached by a technician, he/she is unavailable (for a specified period of time) for production activities, regardless of his/her certification status.

Facility allocation is complicated by safety and security considerations. There are fifteen types of facilities, with multiple sub-types, each governed by a set of rules, including fissile and explosive material limits, as well as environmental and physical requirements. Furthermore, a hierarchy exists among these facilities, so that an operation which is normally performed in a facility of type A can also be performed in a facility of type B, but the converse is not true.

An additional complicating factor is limited storage capacity. Storage facilities are used both to stage incoming weapons (to be evaluated or dismantled) and to store parts removed from the weapons (either temporarily or permanently). Because of tight storage (or staging) capacity, the arrival, staging, and shipment of weapons and the storage/staging and shipment of parts must be closely monitored and controlled to support a production plan and schedule. As might be expected, the storage facilities, like the production facilities, are governed by complex safety and security rules.

PROBLEM FORMULATION

The overall production planning problem can be formulated as a very large mixed integer programming (MIP) problem, in which the objective is to maximize disposal throughput (numbers of weapons dismantled, of various types) over a one-year planning horizon. The constraints include support of required evaluation activities and resource availability limits (facilities, technicians and storage). We will explain the construction of the constraints on technician use and allocation quite thoroughly, but give only a brief summary of the facility and storage use constraints.

For the dismantlement operations, the basic time unit is one month. The actual disposal output in each month, V_{st} , is defined in terms of the units processed through particular operations, since the operations are weapon-specific. Each operation requires a facility and technicians with the correct certification. The model focuses on the flow of units through the system, and the consumption of resources is measured in facility-hours and person-hours.

If we let $s(i)$ be the weapon system to which operation i belongs, we can write the consumption of technician person-hours by disposals for a particular certification c , in month t , as follows:

$$\sum_{i \in I_c} u_i z_i V_{s(i)t} \quad (1)$$

where I_c is the set of operations, i , for which certification c is valid; u_i is the number of machine hours required to perform operation i ; and z_i is number of technicians required for operation i .

In contrast, the evaluations require specific sets of tasks to be performed. Precedence exists, although some tasks can be undertaken in parallel. A good example is a lab test. It involves partial disassembly of the weapon, assembly of a test bed, conduct of the test, disassembly of the test bed, and rebuild of the weapon. These steps must be done in sequence, and within each step, more detailed tasks exist, some of which may be performed in parallel. "Due dates" are common for the intermediate tasks (e.g., for completion of the test bed), and meeting these dates has high priority. Also, tasks have priorities, such as disassembly of the test bed following the test. Lower priority tasks can be "fit in" around the higher priority ones on a resource-available basis. Thus, the evaluation planning module solves a resource-constrained project scheduling problem, building on Bell and Han (1991) and Icmeli and Rom (1996).

These evaluation activities share technicians and facilities with disposals, but the required level of detail in terms of timing is much finer than for disposals. Individual tasks must be tracked, and these tasks require anywhere from a few hours to several days. Consequently, short time periods, t' , are defined, and these are "rolled up" to gain resource utilizations that mesh with the disposal activities. If we use t to denote months in the planning horizon ($t = 1, 2, \dots, 12$), and t' to represent the smaller periods used for tracking evaluation activities. Then the "roll up" creates the following variables where $\beta(t')$ is the length of period t' (hours) and $T(t)$ is the set of periods, t' , contained in month t .

Now, we can write a set of constraint equations to ensure that sufficient technician resources (with a specific certification) are available to support all planned activities (disposals and evaluations) in each month.

$$\sum_j \sum_{l=t'}^{t'+d_j-1} g_{jk} v_{jk} = \Gamma_{kt} \quad \forall k, t' \quad (2)$$

$$\sum_{i \in I_c} u_i z_i V_{s(i)t} + \sum_{t' \in T(t)} \Gamma_{k_c t'} \beta(t') - \sum_e x_{ect} - D_{ct} = 0 \quad \forall c, t \quad (3)$$

where d_j is the duration of task j ; g_{kj} is the number of units of resource k required for task j ; Γ_{kt} is the units of resource k required during period t ; $v_{jt'}$ is equal to 1 if task j ends in period t' and 0 otherwise; x_{ect} is the person-hours of employee e allocated to using certification c in month t ; and D_{ct} is the excess person-hours of certification c used in month t .

Constraint (2) is used to define the amount of resource k used in period t' . Constraint (3) then ensures that sufficient person-hours of time (from technicians with the correct certifications) are allocated to support both disposal and evaluation activities. In (3), k_c is used to designate the resource index which corresponds to certification c . The variable D_{ct} for "excess technician hours" in (3) helps remove the possibility that the PPM can terminate with "no feasible solution," leaving the users at Pantex wondering why that happened. These variables are added to the objective function as penalty terms, so the solution will not normally include them, but if a problem setup is created for the PPM which really is infeasible, the output values of D_{ct} help show why.

The period in which each evaluation task ends is determined by the solution, with constraints to ensure that precedence relationships among the tasks are observed, as shown in constraints (4) and (5). Constraint (4) ensures that each task is scheduled to end in one (and only one) period. Additionally, we will define the index, J , to denote a "task" that has no duration, but whose completion is dependent upon completion of all other tasks. Thus, the period t' in which $v_{Jt'}$ is 1 denotes the completion of all evaluation tasks. The limits on the summation, e_j and τ_j , in (5) are determined prior to the optimization, based on due dates and precedence relations among the tasks.

$$\sum_{t=e_j}^{\tau_j} v_{jt} = 1 \quad \forall j \quad (4)$$

$$\sum_{t=e_j}^{\tau_j} (t-d_j) v_{jt} - \sum_{t=e_j}^{\tau_j} t' v_{l't} \geq 0 \quad \forall j, l \in P_j \quad (5)$$

where e_j is earliest time at which task j can end, based on the earliest possible start time for the evaluation activity of which j is a part, and the precedence relationships among the tasks; τ_j is the latest time for completion of task j , based on required due dates and precedence relationships among the tasks; and P_j is the set of all tasks which immediately precede task j .

Technician-hours (reflected by the x_{ect} variables) are allocated based on the availability of individual technicians, maximum allowable radiation exposure, and crew-size requirements for specific operations. If S_{et} is the hours available for technician e in month t , one set of constraints is:

$$\sum_{c \in C_{et}} x_{ect} \leq S_{et} \quad \forall e \quad (5)$$

The radiation exposure constraints, which ensure that no technician is allocated to tasks in such a way as to violate the acceptable exposure level, are written as follows:

$$\sum_t \sum_i r_i x_{ec(i)t} \leq U \quad \forall e \quad (6)$$

where $c(i)$ is the certification required for operation i .

The crew size requirements imply, for example, that if a particular operation requires two technicians, and a total of 180 technician-hours in a given month, we want to allocate two technicians for 90 hours each, not one technician for 160 hours and a second for 20 hours. To make sure that the total allocation of person-hours is spread across sufficient technicians to allow staffing of the operations, we limit each of the individual allocation terms, as follows:

$$x_{ect} - \sum_{i \in I_c} u_i V_{s(i)t} \leq 0 \quad \forall e, c, t \quad (7)$$

The consumption of facility resources (facility-hours) is represented in a similar way to technicians, but with greater detail in some respects and less in others. The overall set of constraints is as follows:

$$\sum_{i \in Y_f} d_i W_{ift} \leq F_{ft} + E_{ft} \quad \forall f, t \quad (8)$$

$$V_{st} = \sum_f W_{ift} \quad \forall t, i \in I_s, s \quad (9)$$

where W_{ift} is the number of units processed through operation i in facility type f during month t ; Y_f is set of operations, i , which can be performed in facility type f ; d_i is the facility-hours required to perform operation i ; F_{ft} is the facility-hours of facility type f available in month t ; and E_{ft} is the excess facility-hours of type f consumed in month t .

Note that the variable definitions refer to facilities of a particular type, since there may be several individual facilities that are identical, and the PPM is only concerned with consumption of facility-hours in a facility of that type, without identifying exactly which facility is involved. The E_{ft} terms are similar to the D_{ct} values in the technician constraints, and must also be added to the objective function as penalty terms on overuse of facility-hours.

The throughput of system s in any month t is connected to the variables which account for the number of units processed through operation i using facility f during month t (W_{ift}). If we denote I_s as the set of operations required for dismantling weapon s , and sum over the facility types, f , we count the total units processed through operation i in month t . By having a "copy" of constraint (10) for each i in I_s , we ensure that all required operations are performed on each unit dismantled.

There is a hierarchy in facility types, and each operation i will have a minimum required facility but can also be assigned to any higher capability facility. Thus, in general, for each i there will be several f values which are feasible assignments. Normally, we will want the solution to assign each operation (as much as possible) to the lowest available facility in the hierarchy. This is accomplished by adding to the objective function a set of usage penalties for assigning an operation to a higher-than-necessary facility type. Such assignments are then feasible, and will be done as necessary to use available facility-hours most effectively, but will be penalized in the objective function.

There may also be bounds on volume throughput. These produce constraint set (10):

$$V_{\min_{st}} \leq V_{st} \leq V_{\max_{st}} \quad \forall \quad s, t \quad (10)$$

where $V_{\min_{st}}$ is the minimum required volume of system s in month t and $V_{\max_{st}}$ is the maximum allowable volume for system s in month t .

In addition to representing the operations necessary for dismantlement, the PPM also tracks inventory balances and inbound/outbound shipment schedules. This integration of storage management within the PPM ensures that the disposal plan developed is internally consistent with the inbound and outbound shipment plans and the on-site storage constraints and logistics.

For units of system s , stored on-site awaiting dismantlement, an inventory balance equation can be written as follows:

$$Q_{st} = Q_{s,t-1} + A_{st} - V_{st} + \alpha_1 Z_s \quad \forall \quad s, t \quad (11)$$

where Q_{st} is the units of system s in storage at the end of month t ; A_{st} is the units of system s which arrive during month t ; Z_s is the additional units of system s that would have to be in inventory (or scheduled to arrive across the planning horizon) to support the disposal plan; and α_1 is 1 for month 1 and 0 otherwise.

The values of A_{st} are assumed to be specified exogenously. The use of the Z_s variables in (5) allows the PPM to find a "solution" to any set of input data, even if the inbound shipment schedule is too small to support the level of system dismantlement demanded by the minimum values, $V_{\min_{st}}$, specified in equation (10). On output, if one of the Z_s variables is nonzero, it

means there is a shortfall in the number of units of system s available (either from initial inventory or the inbound arrival schedule) to support the dismantlement schedule that the model has developed.

An analogous set of constraints is defined to maintain the inventory balance for parts stored on-site after dismantlement:

$$R_{pt} = R_{p,t-1} + \left(\sum_s \sum_{i \in I_s} n_{ip} V_{st} \right) - G_{pt} + \alpha_1 L_p \quad \forall p, t \quad (12)$$

where R_{pt} is the units of part p in storage at the end of month t ; n_{ip} , the units (pieces, kg, etc.) of part p removed (from weapon system s) in operation I ; G_{pt} is the units of part p which are shipped off-site during month t ; L_p is the number of "pseudo-parts" of part p shipped in month t to meet shipment requirements; and α_1 is 1 for month 1 and 0 otherwise.

The values of G_{pt} are assumed to be exogenous input to the model. The L_p variables act for parts the same way the Z_s variables act for incoming systems, to indicate the shortfall in parts generation (e.g., due to a lower-than-needed) dismantlement schedule, to support the planned parts shipments in the input dataset.

The on-site storage representation also connects the numbers of weapons and parts stored to the amount of space consumed for various configurations of the available storage facilities. If we index the configurations by j , then we can create two variables: ξ_{sj} , which is 1 if system s is to be stored in configuration j and 0 otherwise; and η_{pj} , which is 1 if part p is to be stored in configuration j and 0 otherwise.

The requirement for space in configuration j in month t is represented by the following set of equations:

$$\sum_s \xi_{sj} \left(\frac{1}{cs_{sj}} \right) Q_{st} + \sum_p \eta_{pj} \left(\frac{1}{cs_{pj}} \right) R_{pt} = M_{jt} \quad \forall m, t \quad (13)$$

where: cs_{sj} is the capacity of a magazine in configuration j for systems of type s ; cp_{pj} is the capacity of a magazine in configuration j for parts of type p ; and M_{jt} is the number of magazines which must be in configuration j during month t (i.e., sufficient to handle the inventory at the end of month t).

Finally, the configurations are limited by the actual physical facilities available. If we let J_m represent the set of configurations possible for a magazine type, m , then these constraints can be written as follows:

$$\sum_{j \in J_m} M_{jt} \leq N_{mt} + B_{mt} \quad \forall m, t \quad (14)$$

where: N_{mt} is the number of magazines of type m available in month t and B_{mt} is the "pseudo storage capacity" variable reflecting a shortfall in storage capacity of type m in month t .

The B_{mt} variables are introduced to represent possible storage capacity shortages, without having the model report "no feasible solution." The values of N_{mt} are input as data, and can be varied from month to month to reflect special considerations like repairs, etc.

The overall PPM objective function includes terms to represent the throughput (being maximized), as well as terms to reflect the added "penalty terms" for the excess technician hours, excess facility hours, pseudo-disposals and pseudo-shipments, and storage facility shortages that have been added to the model to prevent conditions of "no feasible solution" from the model, as well as the facility usage penalties. The resulting objective function is:

$$\begin{aligned} \max \sum_t \sum_s \lambda_s V_{st} - \gamma \sum_t \sum_c D_{ct} - \delta \sum_t \sum_f E_{ft} - \pi \sum_s Z_s \\ - \nu \sum_p L_p - \omega \sum_m \sum_t B_{mt} - \sum_i \sum_c \mu_{if} \sum_t W_{ift} \end{aligned} \quad (15)$$

This objective maximizes the system's (weighted) throughput, where the λ_s values reflect the possibility of different importance (weights) being placed on dismantlement of different systems. The second through sixth terms are penalty terms, with multipliers that must be set large enough to ensure that the model will not violate one of those constraints to increase throughput. Consequently, the sums from these five terms should normally be zero; otherwise, we actually have an infeasible solution.

The last term in (15) is the usage penalty for performing operations in higher-than-necessary facility types. The value of the multiplier μ_{if} is the per-unit penalty for performing operation i in facility type f . For the minimum required facility for operation i , this value is zero. For facility types of higher capability, μ_{if} should be positive, with larger values associated with facilities of greater capability. However, on the whole, the μ_{if} values should be small, relative to the system weight coefficients in the first term of (15). In practice, the μ_{if} values are determined automatically within the model, based on the other input data.

The overall problem (P) is then:

Maximize (15)

Subject to: (1)-(14)

where it is understood that there is a copy of constraint (11) for each month, t .

THE SOLUTION

To solve problem **P** in a manageable fashion, a modular structure is employed, as shown in Figure 2. This modularity facilitates modification of the model to meet new or changing requirements. It also allows substitution of other components, such as alternate GIS software, data base management system, or optimization software.

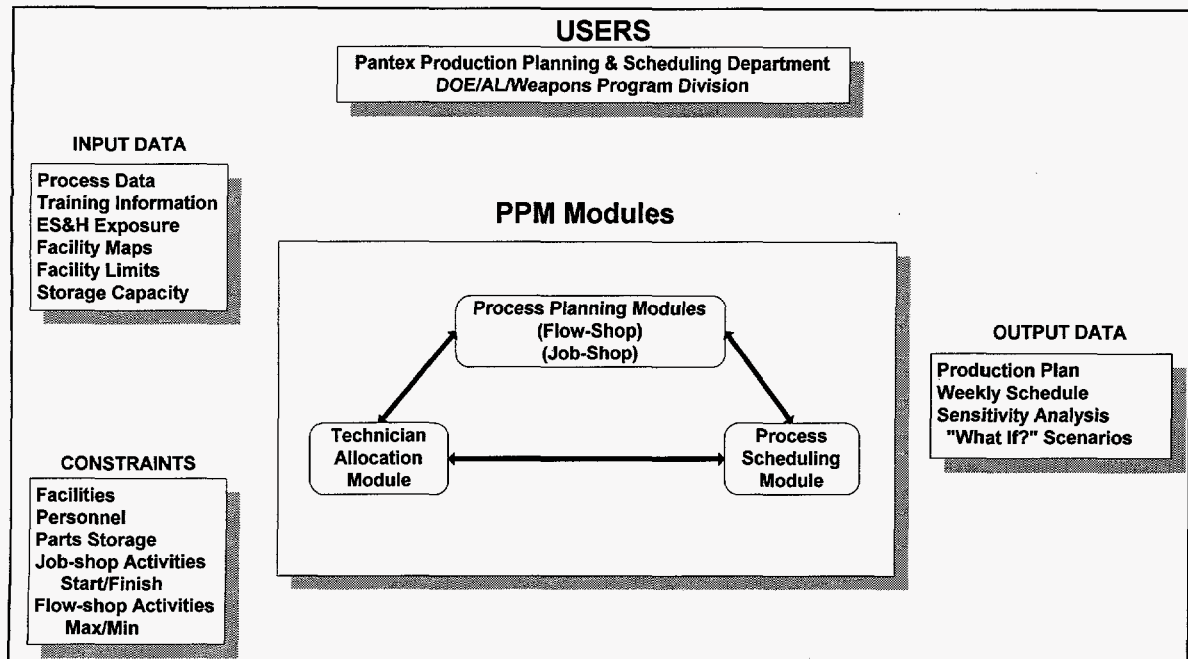

Figure 2: Graphical depiction of the PPM, showing its modular nature

The PPM has modules for planning disposal (DPM) (Flow-Shop) and evaluation (EPM) (Job-Shop) activities as well as a technician allocation module (TAM) and a process scheduleability module (PSM). The following paragraphs describe how each of these modules functions, and how they are interconnected.

DPM – The DPM is a large-scale linear programming model that seeks to maximize the total number of units disassembled over a one-year planning horizon, subject to constraints on facility availability, technician availability, available space for storage/staging of both incoming units and outgoing parts/subassemblies, and mandated program requirements for specific weapon systems. Its output is an optimal disposal plan, on a monthly basis, for a one-year planning period. Because the DPM is a linear programming model, the solution also yields valuable sensitivity analysis information, such as shadow prices that indicate how much the total throughput be increased if additional hours of a given resource were made available. The binding constraints in the DPM solution identify the choke points in the process, and allow the users at Pantex to determine whether the number of disposals is being limited by facility availability, technician availability, storage/staging availability, etc.

The user interface for the DPM allows the staff at Pantex to focus on providing input data in a form they are familiar with, and getting output that is as graphical as possible to facilitate un-

derstanding and communication with other parts of the Pantex operation. The interface also allows them to quickly change selected inputs and rerun the model, to respond effectively to "what if" questions from DOE, or to change the disposal plan to reflect the influences of unanticipated disruptions in the over process, from whatever source they arise.

EPM – The EPM creates a plan for conducting a set of prespecified stockpile evaluation activities over the course of a one-year planning period. Typically, each of these activities involves an earliest possible start time, a due date for completion, and a specified set of operations that must be performed in a particular order. Each operation requires a certain facility type, and technicians with particular certifications. The overall facility pool and set of available technicians are shared with the disposal activities. The solution to this problem is based on techniques for multi-project, constrained resource, project scheduling (see, for example, Bell and Han, 1991). The output of the EPM is a proposed plan, on a week-by-week basis, for conducting the required evaluation activities, and a specification of what resources must be allocated to those activities in each week.

The essential idea embedded in the solution procedure for the EPM is to level the resource demands subject to the time window constraints on the tasks and the precedence requirements. In general, for situations of realistic size, this is a very complicated problem, so a heuristic is employed.

It is clear that the DPM and EPM are closely connected, because they are used to plan activities that compete for a common set of resources (facilities and technicians). For facilities, the modules interact directly to ensure that the available facility-hours of each facility type are efficiently allocated between disposals and evaluations. For technicians, the interaction is more complex, because both the DPM and the EPM are seeking available technician-hours for particular certifications, and individual technicians often hold multiple certifications. Thus, the interaction between the planning modules for technicians requires a third module.

TAM – The Technician Allocation Module determines allocations of technician-hours in each month of the one-year planning horizon to demands for person-hours of various certifications, arising from the DPM and EPM. The model takes the form of a network optimization for each month, with linking constraints across the months of the year to prevent overexposure of any individual technician to radiation. Figure 4 illustrates the network structure of the model, in which the "supplies" (available hours for a specific technician with given certifications) are allocated to meet the "demands" (required technician-hours, by certification, within a given month). A "pseudo-source" is included to identify any infeasibilities which must be resolved by iteration with the DPM and EPM. The resulting network problem can be solved very efficiently, using specialized algorithms (see, for example, Bertsekas, 1991).

In a typical application, the DPM and EPM are run first, using "infinite" technician resources, to generate a desired level of technician-hours in each certification. Then the TAM is run to determine how many hours in each certification is actually supportable by existing technicians. These values are then fed back to the DPM and EPM, resulting in new plans. The iteration among the DPM, EPM and TAM continues until consistent results are achieved.

PSM – When a consistent plan (involving disposals, evaluations and technician allocations) has been developed, the PSM is invoked to check for scheduleability: that a given plan could be converted into actual assignments of specific people and facilities to specific tasks. Typically the time frame employed is 2-4 weeks. This is the time when which detailed requirements and special regulations are taken into account to ensure the feasibility of the planned activities. If infeasibilities are uncovered at the this level, it is necessary to return to the planning modules and revise the overall plan.

RESULTS IN APPLICATION

The potential productivity increases achieved from use of the PPM can be substantial. The Pantex Production Planning and Scheduling Department expects to achieve significant improvement in the following areas:

- *total production output* – the PPM allows Pantex to achieve *optimal* production output, as opposed to settling for the first *workable* plan and schedule that they found.
- *time required for planning and scheduling* – use of the PPM cuts the response time for rescheduling production activities after a disruption and for replying to “what-if” questions from days to hours, while increasing the confidence in the answers achieved.
- *allocation of technicians* – optimal assignment of the technicians requires juggling thousands of variables, which is an impossible task to do well without computer support. The PPM optimally assigns technicians, as well as provides guidance on future training requirements.
- *allocation of facilities* – the PPM is used to assign specific facilities for specific tasks in an optimal manner, taking into account maintenance activities.
- *identification of potential choke points* – for production planning and risk management purposes, it is important to understand which processes control production output. The PPM identifies such choke points (including the geographic location) and presents valuable sensitivity analysis information, which allows the users at Pantex to determine whether the output is being limited by facility availability, technician availability, storage/staging availability, etc.

We have also successfully demonstrated, elsewhere, that the integration of a geographic information system with the PPM can provide direct facility impact information related to an on-site inspection, as well as how the potential impact could be minimized through intelligent routing of the inspectors in conjunction with the option analysis capabilities of the PPM.

In addition, PPM technology, enhanced with routing analysis capabilities, makes it possible to measure the impact of uncleared visitors (such as on-site inspections in support of treaty verification, etc.) and offers the intriguing possibility of analyzing trade-offs and minimizing potential impacts on normal operations.

REFERENCES

1. Bell, C.E. and J. Han (1991). "A New Heuristic Solution Method in Resource-Constrained Project Scheduling," *Naval Research Logistics*, 38, pp. 315-331.
2. Bertsekas, D.P. (1991). *Linear Network Optimization: Algorithms and Codes*, MIT Press, Cambridge, MA.
3. Icmeli, O. and W.O. Rom (1996). "Solving the Resource Constrained Project Scheduling Problem with Optimization Subroutine Library," *Computers and Operations Research*, 23:8, pp. 801-817.
4. Morton, T.E. and D.W. Pentico (1993). *Heuristic Scheduling Systems*, John Wiley & Sons, New York.
5. Nagel, R.N. and P. Bhargava (1994). "Agility: The Ultimate Requirement for World-Class Manufacturing Performance," *National Productivity Review*, Summer 1994, pp. 331-340.

DISCLAIMER

This report was prepared as an account of work sponsored by an agency of the United States Government. Neither the United States Government nor any agency thereof, nor any of their employees, makes any warranty, express or implied, or assumes any legal liability or responsibility for the accuracy, completeness, or usefulness of any information, apparatus, product, or process disclosed, or represents that its use would not infringe privately owned rights. Reference herein to any specific commercial product, process, or service by trade name, trademark, manufacturer, or otherwise does not necessarily constitute or imply its endorsement, recommendation, or favoring by the United States Government or any agency thereof. The views and opinions of authors expressed herein do not necessarily state or reflect those of the United States Government or any agency thereof.
