

CONCEPTUAL DESIGN FOR THE NSTX CENTRAL INSTRUMENTATION AND CONTROL SYSTEM*

RECEIVED
OCT 27 1997
OSTI

D. BASHORE, G. OLIARO, P. RONEY, P. SICHTA, K. TINDALL
Princeton Plasma Physics Laboratory,
Princeton, New Jersey, United States of America

ABSTRACT. The design and construction phase for the National Spherical Torus Experiment (NSTX) is under way at the Princeton Plasma Physics Laboratory (PPPL). Operation is scheduled to begin on April 30, 1999. This paper describes the conceptual design for the NSTX Central Instrumentation and Control (I&C) System. Major elements of the Central I&C System include the Process Control System, Plasma Control System, Network System, Data Acquisition System, and Synchronization System to support the NSTX experimental device.

1. INTRODUCTION

The National Spherical Torus Experiment (NSTX) is an alternate concept, proof-of-principle scale fusion device designed to investigate the physics issues of spherical torus (ST) plasmas [1] [2]. The NSTX design and construction project is a national collaboration among several institutions including Columbia University, the Oak Ridge National Laboratory (ORNL), the Princeton Plasma Physics Laboratory (PPPL), and the University of Washington at Seattle. The NSTX device will be built at PPPL to take advantage of existing equipment and infrastructure. A global requirement imposed on the design of the NSTX Central I&C System is to utilize existing PPPL resources to the maximum extent possible to reduce cost and fabrication time.

Once operational on April 30, 1999, the NSTX machine is designed to operate for a period of 10 years. For inductive operation, the pulse length is 0.5 second and the pulse repetition period is 600 seconds with a maximum of 48 pulses per 24 hour period. For non-inductive operation, the pulse length is 5 seconds and the pulse repetition period is 300 seconds with a maximum of 96 pulses per 24 hour period. The most aggressive operating scenario, from a Central I&C perspective, is assumed to consist of 96 five second pulses per day, 5 days per week, 3 weeks per month, 9 months per year, for 10 years (total of $\approx 130,000$ pulses), with non-operating times available for maintenance.

Functionally, the NSTX Central I&C System will provide process control and monitoring (both continuous and sequential), real-time control for plasma positioning, computer networking for inter-system communications and data transfer, safety interlocks (master supervisory control of the experiment), and access control (control and monitoring of access to the NSTX Test Cell). The system will also support the sampling, acquisition, storage and display of diagnostic data, and synchronize data sampling triggered from master clock events. The system will provide researchers with access to the facility in support of the operation, physics planning, analysis and coordination of experimental objectives.

In early February, 1997, a Conceptual Design Review (CDR) of the proposed Central I&C System was successfully completed. Many recommendations from the CDR have been folded into the current design. An Engineering Cost and Schedule Review followed three weeks later to endorse the cost and schedule estimates. The bottoms-up cost estimate included vendor quotations for specific software applications, computer hardware and other components.

The configuration and components presented in this paper are subject to change during the preliminary and final design phases. In light of this fact, new component information is provided without reference to a specific model number. In cases where existing equipment is reused, more details are provided, as the design is less likely to change. This paper describes the conceptual design for the Process Control, Plasma Control, Network, Data Acquisition, and Synchronization Systems.

* Work performed under the auspices of the USDOE by Princeton Plasma Physics Laboratory under Contract No. DE-AC02-76CH03073.

2. PROCESS CONTROL SYSTEM

The NSTX project is considering the use of the Experimental Physics and Industrial Control System (EPICS) [3] to create a Process Control System. While the conceptual design is based on EPICS, a final selection will not be made until alternatives are evaluated. EPICS is a set of software tools and applications cooperatively developed by Los Alamos National Laboratory, Argonne National Laboratory, Thomas Jefferson National Accelerator Facility, Lawrence Berkeley Laboratory and others. The EPICS collaboration currently consists of more than 44 major DOE labs, universities and industry partners. As a DOE-funded facility, PPPL obtains EPICS at no cost. EPICS can satisfy all of the NSTX Process Control System requirements. A block diagram of the NSTX configuration is shown in Fig. 1.

NSTX will use many of the PPPL engineering subsystems which supported the decommissioned Tokamak Fusion Test Reactor (TFTR). CAMAC interfaces will be retained for the D-Site Motor Generators, Field Coil Power Supplies, the Ion Cyclotron Radio Frequency System and several smaller subsystems. TFTR CAMAC interface

information and engineering configuration parameters reside in the Master Device Table (MDT) ASCII files. EPICS can accept ASCII data files to define the I/O point configurations. Ideally, the TFTR MDT files can be reformatted and used as a basis to generate an NSTX EPICS database. A fundamental requirement to reuse CAMAC is imposed by budget constraints, as the cost to purchase and install new interfaces, rewire terminations, and revise documentation would draw funding from mission-critical tasks. Supervisory Allen-Bradley (AB) PLC interfaces will be included for the Vacuum Pumping System and the Glow Discharge System. Direct AB PLC I/O interfaces will support the Water Cooling System, Bakeout System and several other subsystems.

The three basic components of EPICS include the Input/Output Controller (IOC), the Operator Interface (OPI), and Channel Access to communicate over a Local Area Network (LAN). An IOC's hardware consists of a VME/VXI chassis and a processor module. In addition, an IOC can also contain a wide range of I/O modules, and VME modules to provide access to other I/O buses. The VME controller runs the

FIG. 1 Process Control System Block Diagram

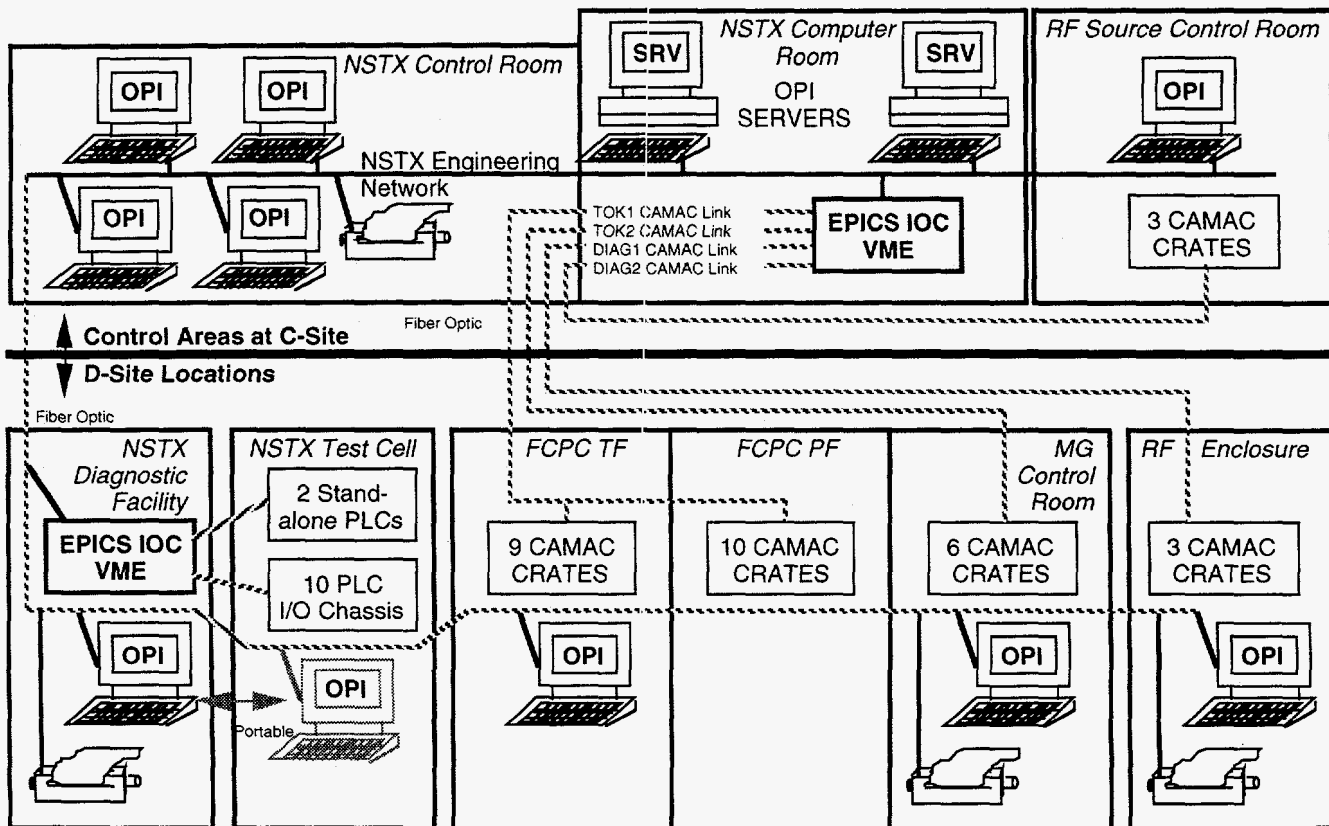

DISCLAIMER

This report was prepared as an account of work sponsored by an agency of the United States Government. Neither the United States Government nor any agency thereof, nor any of their employees, makes any warranty, express or implied, or assumes any legal liability or responsibility for the accuracy, completeness, or usefulness of any information, apparatus, product, or process disclosed, or represents that its use would not infringe privately owned rights. Reference herein to any specific commercial product, process, or service by trade name, trademark, manufacturer, or otherwise does not necessarily constitute or imply its endorsement, recommendation, or favoring by the United States Government or any agency thereof. The views and opinions of authors expressed herein do not necessarily state or reflect those of the United States Government or any agency thereof.

DISCLAIMER

Portions of this document may be illegible in electronic image products. Images are produced from the best available original document.

Wind River Systems VxWorks real-time operating system. An IOC's software consists of EPICS routines to support database and I/O processing. OPI platforms include workstations running UNIX or VMS, and PCs running Windows or Linux. An OPI's software consists of EPICS applications to support database configuration and operator interface. Channel Access supports a variety of LANs (e.g. Ethernet, FDDI, ATM) using the TCP/IP protocol to support inter-system communications.

The NSTX implementation of EPICS consists of two IOCs to distribute the control and monitoring burden. The first IOC consists of a VME chassis housing a PowerPC controller and CAMAC Serial Highway Driver VME modules. This IOC connects to four existing bit-serial CAMAC links that support 2000 existing I/O points and 150 existing data acquisition channels. These links currently connect all of the baseline engineering subsystems and terminate in the NSTX Computer Room. Consolidation of these links to some extent during the preliminary design phase will reduce the number of components to improve reliability and maintainability. A second EPICS IOC consists of a VME chassis housing a PowerPC controller and an AB VME Scanner card (SV-6008) to support 900 new I/O points. This IOC ties in two standalone Allen-Bradley PLCs, each equipped with an AB Direct

Communications Module. In addition, AB I/O is directly connected via Remote I/O Adapters.

The EPICS OPI function is supported by two Sun workstations and nine NCD Network Computers, serving as X-terminals. Nine operator interface displays are provided; 4 displays are located in the NSTX Control Room and 5 are dispersed in field locations such as the MG Control Room. The OPIs provide the operator interface to display mimic pages, alarm annunciation, and the trending of variables.

The NSTX Engineering Network, supporting EPICS Channel Access communications between IOCs and OPIs, is described in Section 4. Channel Access provides network transparent access to IOC databases. It is based on a client-server model. Each IOC provides a Channel Access server to communicate with its clients. Channel Access client services are available on both IOCs and OPIs.

3. PLASMA CONTROL SYSTEM

The NSTX Plasma Control System conceptual design is based on a VME real-time 4-CPU SKYbolt I computer to perform real-time control for plasma positioning. A block diagram of the system is shown in Fig. 2. The system includes a Themis 10-mp host computer, various I/O

FIG. 2 Plasma Control System Block Diagram

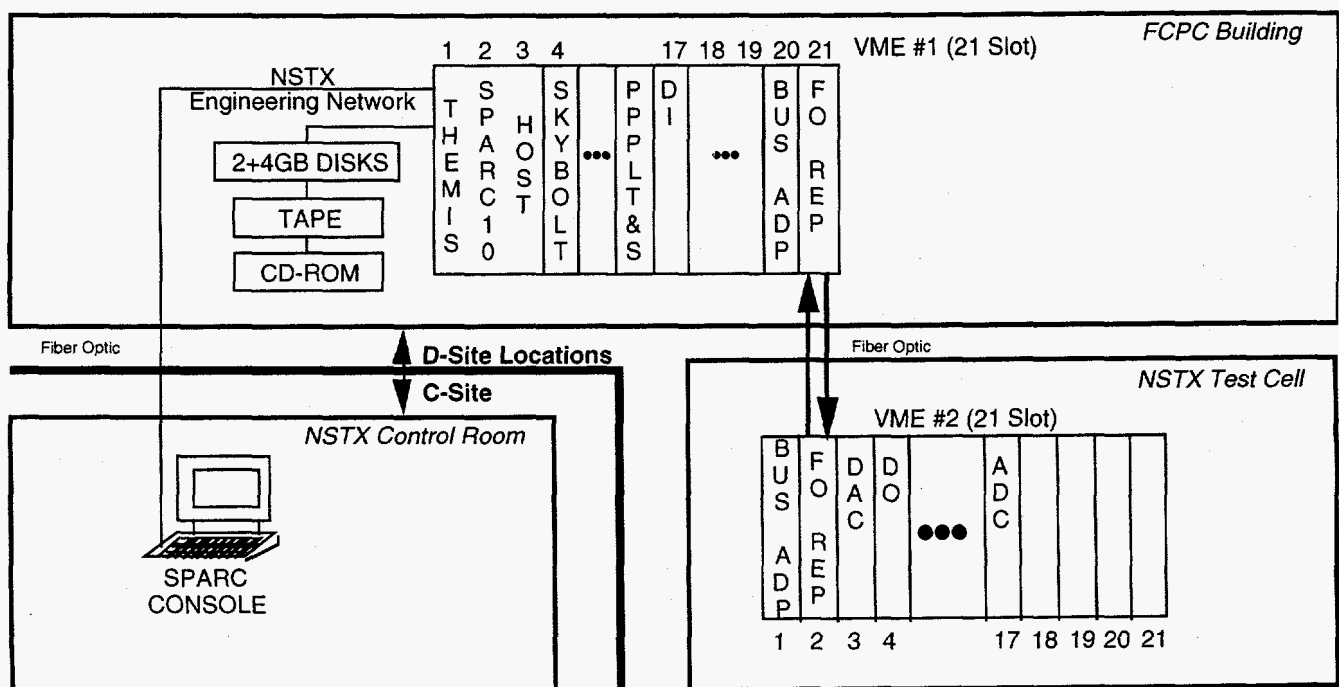

modules (16 CH DAC, 64 CH ADC, 16 bit D/O, and 64 bit D/I) and a PPPL-designed timing and synchronization module to interface to the NSTX Synchronization System. The NSTX Plasma Control System is based on the hardware originally purchased to perform plasma control on the Princeton Beta Experiment Modification (PBX-M) tokamak [4]. This system was subsequently used on TFTR for plasma control, and radiated power feedback experiments. The conceptual design reuses the hardware, operating system, applications and Web interface to the maximum extent possible.

The supervisory computer, real-time computer and some of the I/O modules (to monitor coil currents and generate coil commands) are located in the FCPC Building. The remaining I/O modules reside in the NSTX Test Cell (to perform magnetic diagnostic measurements). For tight coupling, fiber optic repeater/bus adapter pairs will extend the VMEbus from the FCPC building to the Test Cell. The hardware configuration will support the required 1 millisecond update frequency of the feedback control algorithm for spherical torus plasmas. The system will be operated from the NSTX Control Room. The display is connected via Ethernet using the NSTX Engineering Network.

4. NETWORK SYSTEM

Two dedicated networks, configured with PPPL's standard Cabletron components, are proposed to support the NSTX experiment. Ninety modular Data Service Outlet network interfaces located throughout the Control Room and the D-Site Facility will provide the physical connection for computers, displays and printers.

The NSTX Engineering Network is a dedicated secure network to support the Process Control System's operation, data acquisition and inter-system communication at the anticipated data loads. The stand-alone TCP/IP based network is isolated from the Internet to protect equipment from inadvertent or malicious incidents. The network consists of 10Mb Switched Ethernet in the NSTX Control Room and 10Mb Ethernet to remote field displays.

The NSTX Physics Network is a dedicated open network to support diagnostic control, operations and data acquisition. The purpose of

this network is to support the NSTX Data Acquisition System's retrieval of 17.5MB of raw data per shot at the early stages of operation. The TCP/IP-based network is accessible via the PPPL network, ESnet and the Internet. It will provide access to NSTX data, as well as the control of diagnostic data acquisition systems, by parties outside of the NSTX Control Room (e.g. remote collaborators, physicists inside and outside of PPPL). The network consists of 100Mb Switched Ethernet for the data acquisition computer and the data analysis cluster and 10Mb Ethernet to support physics displays. A 10Mb connection to the PPPL router is initially planned to support remote access. Internet Protocol (IP) filtering will block undesirable packets based on the source and destination IP addresses.

5. DATA ACQUISITION SYSTEM

The NSTX project is considering the use of MDSplus [5] to create a Data Acquisition System. While the conceptual design is based on MDSplus, a final selection will not be made until alternatives are evaluated. MDSplus stands for Modular Data System plus; the plus is a tree-based upgrade to the original flat-file based MDS. It was cooperatively developed by MIT's Plasma Science and Fusion Center (PSFC), the ZTH Group at Los Alamos National Lab and the RFX Group at CNR in Padua, Italy and is currently in use at 4 locations around the world. Representatives from PSFC have invited the NSTX project to join the collaboration; they have offered the MDSplus system in its current state at no cost to PPPL. MDSplus is a viable data acquisition and handling system that can be configured to meet the requirements of NSTX. A block diagram of the system is shown in Fig. 3.

The NSTX implementation of MDSplus consists of an OpenVMS based DEC Alpha data acquisition workstation controlling two SCSI CAMAC Serial Highway Drivers. Enhanced block transfer mode capability will acquire digitized data from 400 digitized diagnostic channels [250 low speed (>100 Hz and ≤ 2 KHz) and 150 moderate speed (>2 KHz and ≤ 100 KHz) signals]. Existing PPPL CAMAC controllers, digitizer modules, power supplies, I/O chassis assemblies and fiber optic data communications modules are configured to interface with NSTX diagnostics.

Data analysis and display will be supported by a cluster of seven DEC Alpha workstations running OpenVMS configured with 7 large displays and serving 13 Network Computers (supporting X-windows). The data acquisition workstation, analysis workstations and NCs are interconnected via the NSTX Physics Network.

The existing PPPL VMS Cluster will be used to provide a data management hardware structure to store and secure experimental results. To enhance collaborations, the ability to support a standard data format (e.g. Hierarchical Data Format [HDF]) in conjunction with current data file formats will be advocated for NSTX data. MDSplus provides a data management software structure to catalog, manage and visualize experimental results for subsequent retrieval and analysis using the MDSplus SCOPE, MDSplus TRAVERSER, Research System Inc's IDL and other applications. Analysis codes, such as EFIT and TRANSP, are graphically interfaced to MDSplus. The MDSplus system is "open" and can accommodate the integration of additional analysis codes specific to PPPL, including possible future spherical torus-specific experimental analysis codes. MDSplus treats all

data types (raw, processed, analysis code output, etc.) in a uniform and transparent manner, making it easy to use. It is a very good data "organizer".

Separate from the MDSplus Data Acquisition System is a standalone Control Room signal display system. The system provides eight electrically isolated, general purpose signal channels between the Test Cell and the Control Room. Similarly, eight electrically isolated, dedicated signal channels to provide real time display of coil and gas injection waveforms are provided. Sixteen Dymec, Inc analog fiber optic transmitter/receiver pairs will provide 1MHz of analog bandwidth per channel. These signal channels provide a stand-alone capability to provide real-time display of critical operating and diagnostic values.

6. SYNCHRONIZATION SYSTEM

The NSTX Synchronization System will make use of the existing TFTR Facility Clock System to synchronize data acquisition. Its CAMAC Clock Encoder module will be used to generate up to 32 preprogrammed synchronous events. Existing

FIG. 3 Data Acquisition System Block Diagram

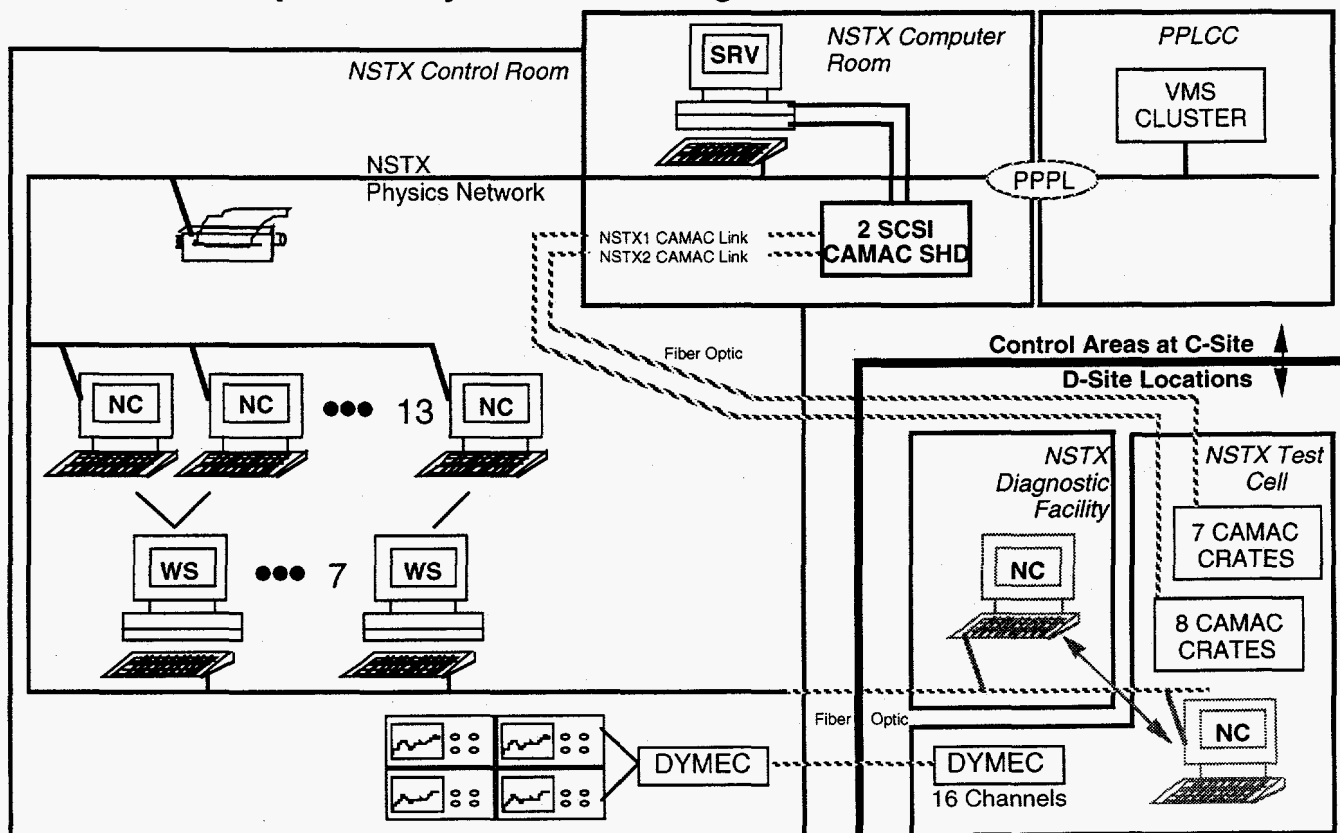

CAMAC Clock Decoder Modules will monitor the encoded timing signal and trigger timing modules in each NSTX subsystem and diagnostic.

The NSTX Synchronization System provides fiber optic transmission to meet electrical isolation requirements at the Test Cell boundary. All of the existing CAMAC locations housing NSTX engineering subsystems are currently interfaced with PPPL's fiber optic synchronization link. The link will be extended to new diagnostic CAMAC locations in the NSTX Test Cell.

It is anticipated that the NSTX CAMAC Synchronization System can achieve 10.0 microsecond simultaneity of data acquisition.

7. CONCLUSION

The conceptual design for the NSTX Central I&C System makes extensive use of existing PPPL components and systems to reduce cost and fabrication time. The system, at its conceptual design level, benefits from collaboration with the high energy physics community through EPICS, and collaboration with the fusion community through MDSplus. During the preliminary design phase, an evaluation of commercial products will be performed to either confirm or redirect our current course. A preliminary design review is scheduled for Fall, 1997 and a final design review is scheduled for Spring, 1998.

8. REFERENCES

- [1] Y-K. M. PENG, D. J. STRICKLER, "Features of Spherical Torus Plasmas," *Nuclear Fusion*, **26** (1986) 576.
- [2] Y-K. M. PENG, "Prospects and Status of Low Aspect Ratio Tokamaks," *Trans. Fusion Technology*, **27** (1995) 138.
- [3] DALESIO, L.R.; KOZUBAL, A.J.; AND KRAIMER, A.J. "EPICS Architecture.", *International Conference on Accelerator and Large Experimental Physics Control Systems*, Tsukuba, Japan. (1991), pp. 278-82.
- [4] BELL, R.E., et al., *Fusion Technol.* **30** (1996) 151.

- [5] J.A. STILLERMAN et al., *MDSplus Data Acquisition System*, 11th Topical Conference on High Temperature Diagnostics (1996)

(E-mail address of D. Bashore:
dbashore@pppl.gov)