

## Development of Lithium Deposition Techniques for TFTR\*

H. W. Kugel, J. Gorman, D. Johnson, G. Labik,  
G. Lemunyan, D. Mansfield, J. Timberlake, and M. Vocaturo

Princeton Plasma Physics Laboratory, Princeton University  
P. O. Box 451, Princeton, NJ, 08543

**Abstract** - The ability to increase the quantity of lithium deposition into TFTR beyond that of the Pellet Injector while minimizing perturbations to the plasma provides interesting experimental and operational options. Two additional lithium deposition tools were developed for possible application during the 1996 Experimental Schedule: a solid lithium target probe for real-time deposition, and a lithium effusion oven for deposition between discharges. The lithium effusion oven was operated in TFTR to deposit lithium on the Inner Limiter in the absence of plasma. This resulted in the third highest power TFTR discharge.

### I. INTRODUCTION

Lithium pellet injection has been found to significantly improve TFTR plasma performance [1, 2]. This has involved using a Lithium Pellet Injector with a capacity of 270 pellets to inject up to four 3 mg lithium pellets per discharge at velocities of about 500 m/sec to near-core regions. However, this approach has both plasma and hardware limitations. The high injection velocities cause near-core deposition and perturbation. In addition, a small pellet size and a small number of pellets per injection are required to prevent disruptions. Consequently, using lithium deposition via pellet injection for plasma surface conditioning requires many discharges and is inefficient. At this time, the optimum lithium characteristics have not been found, and little is known about the detailed plasma surface physics and chemistry of lithium deposited on graphite limiter surfaces [3]. The ability to increase the quantity of lithium deposition while minimizing perturbations to the plasma would provide interesting experimental and operational options. This motivated developmental work on two additional lithium deposition tools in 1996: a Solid Lithium Target (STL) probe for real-time deposition and a Lithium Effusion Oven for deposition between discharges.

### II. SOLID TARGET LITHIUM PROBES

#### A. Solid Target Probe Technique

The successful use of a solid target probe technique for Solid Target Boronization (STB) on PBX-M [4] motivated the search for a possible embodiment of the same approach for lithiumization. On PBX-M, plasma ablation of boronized probes was performed 31 times. STB was applied by inserting special probes into the edge plasma. The probes contained 40  $\mu\text{m}$  diameter boron loaded into graphite-felt using a flotation technique [4]. The resulting boronizations endured 1 sec long high power PBX-M discharges at a rate of about 120 per day.

2-3 applications per week were sufficient. 10 or more boronizations were applied per probe [5].

This work suggested that lithium evaporation into the edge plasma should be achievable from STL probes. In principle, an STL probe should be capable of many lithiumizations, and the total evaporation per discharge should be determined by the probe temperature (edge position), probe surface area, and plasma discharge length. In an effort to build on this experience, three approaches to developing STL probes were investigated; the absorption of liquid lithium into graphite-felt, the flotation of lithium carbide into graphite-felt, and the deposition of lithium vapor in graphite-felt for conversion to lithium carbide.

#### B. Absorption of Liquid Lithium

The low melting point of lithium (180  $^{\circ}\text{C}$ ) implied the possibility of melting lithium into a suitable matrix that could be used as an ablation probe for STL. However, attempts to melt lithium into high purity, porous graphite-felt resulted in low yields. This was attributed to the high surface tension of liquid lithium which prevented lithium from wetting and soaking into the graphite-felt.

#### C. Absorption of Lithium Carbide

The pyrophoric reactivity of pure lithium powder makes it difficult to use in techniques involving the direct flotation of fine grained lithium suspended in a suitable liquid (i.e. not containing water or free radicals). Lithium carbide, however, is relatively inert in dry air, and lithium vapor pressure from the

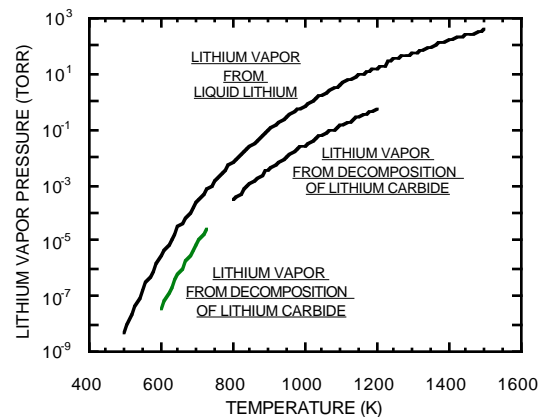

Fig.1. Li vapor pressure from Li and Li<sub>2</sub>C<sub>2</sub> versus temperature.

\* Supported by US DOE Contract No. DE-AC02-76-CHO3073.

decomposition of lithium carbide is adequate at practical temperatures (Fig.1). Useful amounts of lithium carbide were deposited into graphite-felt using lithium carbide powder suspended in xylene. Upon analysis of the resultant probes, however, it was found that impurities in the xylene converted most of the lithium carbide into unsuitable lithium oxide and lithium nitride. Variations of this technique at lower temperatures might stabilize the lithium carbide but were not investigated.

#### D. Lithium Vapor Deposition in Graphite-Felt

During this work, the observed high reactivity of lithium with graphite at high temperatures suggested the investigation of the production of lithium carbide in graphite-felt. About 1 gm amounts of pure lithium were placed with graphite-felt in a closed tube-oven. The tube-oven consisted of a 2.5 cm diameter, 304-SS tube about 10 cm long with one end pinched-closed and a removable plug in the other. A bias was applied to the tube-oven to ohmically heat it to 850-900 °C for about 10 min. This resulted in producing sufficient lithium carbide within the graphite-felt matrix to give evaporable lithium yields of about 33-37%. Table 1 shows typical probe sizes and the lithium mass bound in the lithium carbide.

Probe Size (cm)	Lithium Mass Bound in Lithium Carbide
5.1 x 1.6 x 1.3 (1 element)	~350 mg (116 pellets)
5.1 x 1.6 x 2.6 (2 elements)	~700 mg (233 pellets)
5.1 x 1.6 x 5.1 (4 elements)	~1400 mg (466 pellets)

Table 1. Probe sizes and yields from lithium vapor deposition in graphite-felt probes. Up to 4 elements could be supported on one STL probe head.

The yields obtained by the vapor deposition technique allow STL probes with available lithium mass (bound in lithium carbide) that exceed the TFTR Lithium Pellet Injector capacity of 270 pellets. STL probes fabricated in this manner were tested off-line in a vacuum chamber by ohmic heating but not on TFTR due to the full 1996 Experimental Schedule.

### III. LITHIUM EFFUSION OVEN

In addition to the STL probes, a unique miniature Lithium Effusion Oven was developed, fabricated, and was operated safely in the TFTR tritium environment from the Bay-D Probe. The Bay D Probe was the only readily available insertion probe available during tritium operations. A collimated Lithium Effusion Oven was mounted on the Bay D Probe, aimed at the TFTR Inner Limiter, and used to apply lithium during the absence of magnetic fields shortly before special discharges. Fig.2 shows the toroidal location of the TFTR Bay D Probe and the toroidal range of lithium deposition on the Inner Limiter. Fig. 3 shows the poloidal location of the Bay D Probe and the poloidal range of lithium deposition on the Inner Limiter.

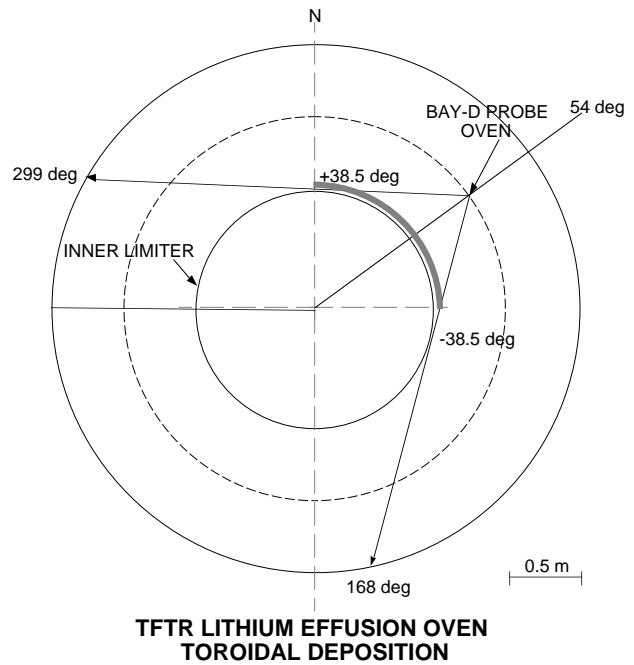

Fig.2. Toroidal location of the TFTR Bay D Probe and the toroidal deposition range of lithium on the Inner Limiter.

The Bay D Probe is a generic sample probe with very constrained geometry and low current instrumentation cabling. This imposed mechanical constraints that limited the Oven dimensions to the available Bay-D Probe space, essentially a cylindrical volume about 6 cm in diameter by 10 cm long. In addition, it was desirable to maximize the lithium deposition on the plasma-wetted surface area of the Inner Limiter, while minimizing deposition on the far outer wall diagnostic windows. Hence, the Bay D Probe distance to the Inner Limiter, about 1.52 m, and the Limiter radius determined the required Oven aperture size and collimation, and the operating temperatures (860 °C) required for practical deposition rates.

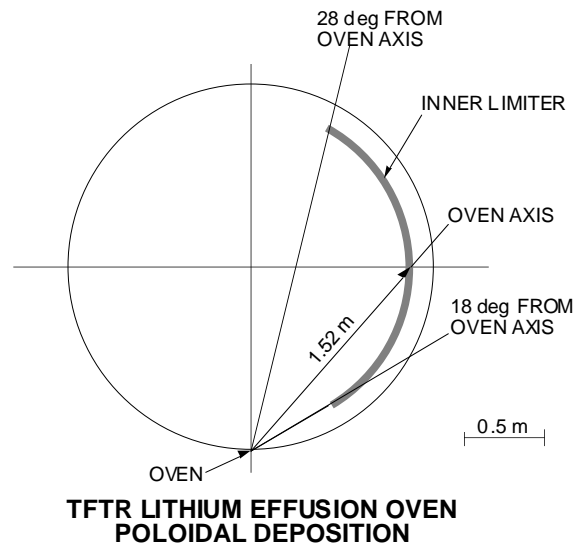

Fig.3. Poloidal location of the Bay D Probe and the poloidal range of lithium deposition on the TFTR Inner Limiter.

The Oven was operated from a position 6 cm below the Last Closed Flux Surface (LCFS) as determined by a nearby RF Limiter. This operating position was chosen for safety in the event that a control malfunction might prevent the withdrawal of the probe from the edge plasma. In addition, in order to prevent possible damage during plasma current disruptions, it was desirable to withdraw the Oven to below the vessel floor after each operation (about 15 cm). However, as discussed below, the selected Oven operating temperature was 860 °C, and TFTR vacuum system procedures would not allow a object at a temperature significantly above typical bakeout temperatures of 150 °C to be lowered into the probe port due to possible local outgassing of impurities. Since it was experimentally desirable to minimize the time between deposition of activated lithium and the subsequent plasma discharge, the Oven mechanical design incorporated shielding to limit the maximum outside shield temperature to 260 °C.

Fig. 4 shows a schematic of the Oven final design. About a 210 mg lithium charge was contained in a small 304-SS, crucible (0.47 cm I.D., with 0.13 cm wall, and 3.81 cm deep). The crucible had a removable lid with an collimating aperture 0.1 cm I.D. by 0.4 cm long (Fig.4A). The crucible was placed in an electrically insulating, thermally conducting, boron nitride mandrel which was heated by 0.05 cm dia. Ta wire (Fig.4B). Special grooves machined on the mandrel allowed the heater wire to be double wound so the both ends of the wire could exit the mandrel surface at the bottom. A type-K thermocouple penetrating through the bottom of the boron nitride heater made contact with the base of the crucible. The boron nitride heater with crucible were mounted within

two 304-SS, heat shields (0.05 cm thick) which also provided additional collimation (Fig. 4C). The oven assembly was mounted within an outer 0.16 cm thick 304-SS heat shield at about a 49° angle aimed at the midplane of the TFTR Inner Limiter (Fig.s 4D and 4E).

The existing Bay D Probe electrical cabling, originally intended for instrumentation wiring, limited applied currents to 10 amps. This current limitation required that the Lithium Effusion Oven be designed for high voltage, low current rather than high current as is the more common method for evaporation ovens. The Oven was operated in the absence of magnetic fields and plasma in a selected time interval between discharges. After each Oven operation, all electrical cables were disconnected to eliminate current paths and the resulting magnetic forces during possible disruptions in TFTR plasma current. If the experimental schedule had permitted, this design would have been upgraded with suitable protection against induced disruption currents to allow maintaining all electrical connections during plasma operations, and thereby facilitate automated operation between discharges.

In order to optimize the focusing and collimation of the Oven design, extensive off-line testing was performed. Fig. 5 shows results of off-line lithium evaporation measurements in a vacuum chamber. The Oven was operated with lithium loads of 50 to 250 mg and evaporations were performed to yield lithium depositions on a glass witness plate located about 10 cm from the exit aperture of the crucible. The deposited lithium film thickness was measured in air using a film thickness measuring stylus immediately after the venting of

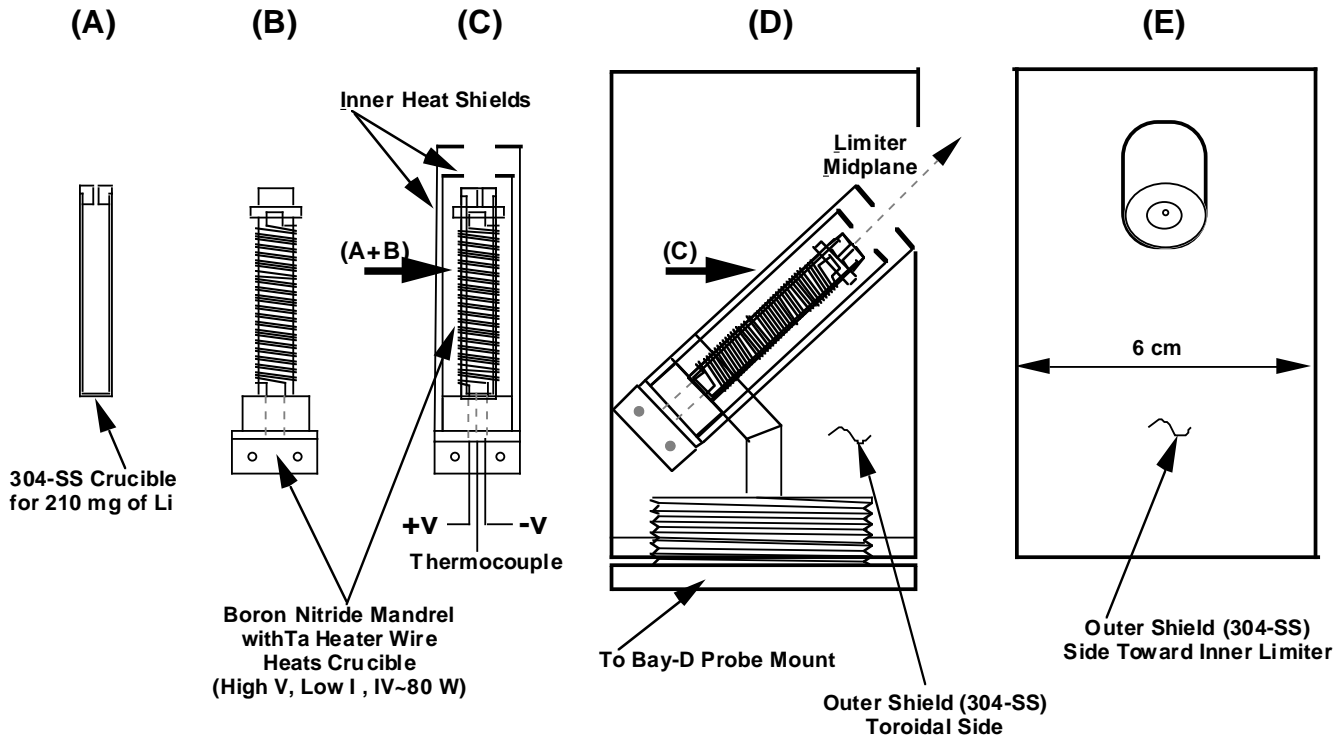

Fig.4 Schematic of the TFTR Lithium Effusion Oven: (A) the 304-SS crucible, (B) the heated boron nitride mandrel into which the crucible is placed, (C) the crucible/heater assembly with the inner and outer heat shields, (D) a side view of the mounting within the outer-most heat shield, and (E) a view of the outer-most heat shield and inner assembly from the side facing the Inner Limiter.

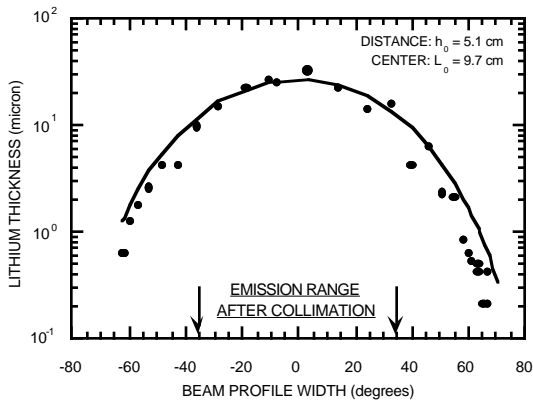

Fig.5 The results of off-line measurements in a vacuum chamber obtained with and without the collimation required to restrict the lithium deposition to Inner Limiter. The solid line is the result of a least-squares-fit of first order evaporation theory to the measured angular distribution.

the vacuum chamber. Shown are measurements obtained with and without the collimation required to restrict lithium deposition on the Inner Limiter, nominally about  $\pm 35^\circ$  toroidally.

Fig.6 shows the effusion rate versus operating temperature for the effusion of 150 mg of lithium from a 1 mm diameter aperture, and the operating time needed to deposit all the lithium. The selected operating temperature of 860  $^\circ\text{C}$  allowed the operation to be completed within 30 minutes. Fig.7 shows the behavior of the respective crucible and outer heat shield temperatures versus time as measured in the off-line chamber. The heater voltage and current were increased from about 10 V, 0.9 A to 39 V, 1.8 A in increments of 1 volt/minute while monitoring the crucible temperature for steady increase.

The lithium used for the off-line testing was natural Li

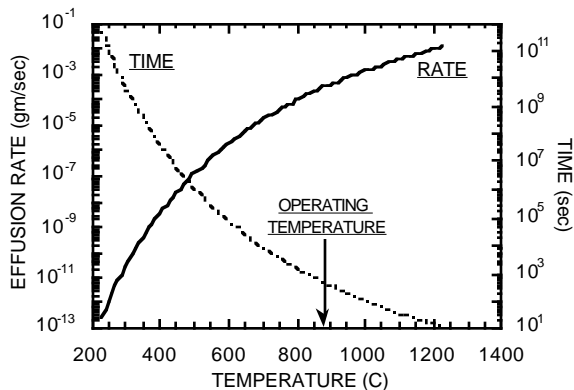

Fig.6. Effusion rate versus operating temperature for the effusion of 150 mg of lithium from a 1.0 mm dia aperture, and the operating time needed to deposit all the lithium

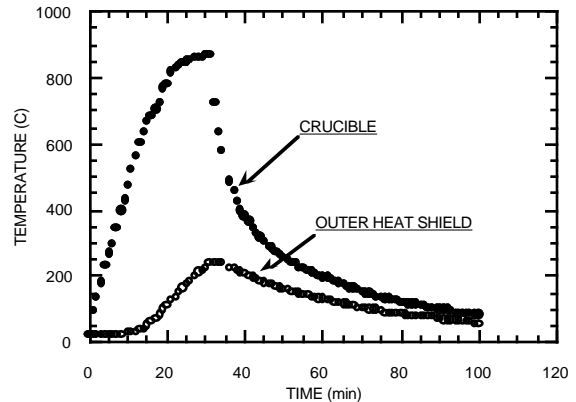

Fig.7. The temperature behavior of the crucible and outer-most heat shield (Fig. 4D) versus time as measured in the off-line vacuum chamber without lithium.

(92.5%  $^7\text{Li}$ ). The lithium was outgassed of any residual packing oil by heating the Oven in the off-line chamber to about 550  $^\circ\text{C}$  for 1 minute prior to operation in TFTR. During an Oven operation for 30 minutes (Fig.7), typically about 85% of the lithium load was evaporated; the remainder appeared to adhere to the walls of the crucible.

## CONCLUSIONS

Lithium Probes with capacities exceeding that of the Lithium Pellet Injector were developed and tested off-line but not inserted into TFTR due to the Experimental Schedule. The Lithium Effusion Oven was operated in TFTR to deposit lithium on the Inner Limiter in the absence of plasma. This resulted in the third highest power TFTR discharge. This Oven design is prototypical of multi-oven designs for extensive lithium deposition between discharges, and with suitable upgrades, could be used for continuous real-time deposition during discharges.

## REFERENCES

1. D. K. Mansfield, *et al.*, "Enhancement of Tokamak Fusion Test Reactor performance by lithium conditioning", *Phys. Plasmas* **3**, 1892 (1996).
2. J. A. Snipes, *et al.*, "Wall conditioning with impurity pellet injection on TFTR", *J. Nucl. Mater.*, 196-198, 686 (1992).
3. J. Hogan, C. Bush, and C.H. Skinner, "Lithium effects in plasmas, summary of the workshop, PPPL, 17-18 October 1996", *Nuc. Fus.*, in press.
4. H. W. Kugel, *et al.*, "Initial boronization of PBX-M using ablation from solid boronized probes", *Fus. Techn.*, **25**, 377 (1994).
5. H. W. Kugel, *et al.*, "Real-time boronization in PBX-M using erosion of solid boronized targets", *J. Nucl. Mater.* **220-222**, 636 (1995).