

SAND96-2468C

CONF-961002--2

RECEIVED

NOV 06 1996

OSTI

System Design and Implementation for the Glass Panel Alignment
and Sealing Tool for Flat Panel Displays

October 16, 1996

J.D. Jordan, P.G. Stromberg, and S.S. Kuszmaul

Guidance & Control Department 2334
Mechanical Engineering Processing Department 1484
Control Subsystems Department 2338

Sandia National Laboratories
Albuquerque, NM 87185

MASTER

This work was supported by the United States
Department of Energy under Contract
DE-AC04-94AL85000.
Sandia is a multiprogram laboratory operated by
Sandia Corporation, a Lockheed Martin Company,
for the United States Department of Energy.

DISTRIBUTION OF THIS DOCUMENT IS UNLIMITED

DISCLAIMER

Portions of this document may be illegible in electronic image products. Images are produced from the best available original document.

Table of Contents

1. Project Description	1
2. Process	1
2.1 Phase I - Air Thermal Sealing	1
2.2 Phase II - Vacuum Sealing	1
3. Hardware Description	1
3.1 Device Description	1
3.2 Optical System Selection	2
3.2.1 Optometrix	2
3.2.2 Navitar/Mitutoyo	3
3.2.3 Infinity	3
3.2.4 Depth of Field and Resolution Limit	3
3.2.5 Lighting	4
3.2.6 University of Arizona Alignment Concepts	4
3.3 Image Stability (Air Jets)	4
3.4 Platen Design	5
3.5 Pneumatics	9
3.6 Motion Hardware	10
3.6.1 Translation/Rotation Stage Selection and Incorporation	10
3.6.2 PM-200 (Camera Z-axis motion)	10
3.6.3 Stage Testing	11
3.6.4 Bellows Mount for Force Compensation/Rotation	11
3.6.5 Thermal Isolation of the Stages from Temperature Environments	11
3.6.6 Vibration Isolation	12
4. Data Acquisition and Control System Hardware	12
4.1 PC	13
4.2 Frame Grabber	13
4.3 National I/O Board	14
4.4 GPIB Communications	14
4.5 Platen Heat Control	15
5. Software Description	17
5.1 LabVIEW	17
5.1.1 User Interface	18
5.1.2 Process Control	19
5.2 Alignment Simulation and Error Equations	19
5.3 Alignment Mark Selection	21
5.4 C Code	21
6. Process Development	23
6.1 Early Thermal Sealing (gap jump)	23
6.2 Aligning by Squishing Plasmaco Furnished Schott Frit	24
6.3 Imaging Across Gap Greater Than Optics Depth of Field	25
7. Testing & Results	26
7.1 Plasmaco Furnished Schott Frit Rod Sealing Tests	26
7.2 SCB-2 Sealing Tests	27
7.3 Ferro Sealing Tests	27
7.4 FED Corporation Small Panel Testing	28
8. Improvements	28
8.1 Proportional Force Feedback	28
8.2 Theta Rotation	28
8.3 Spring Method of Platen Leveling	28
8.4 Pneumatic Controls	29
8.5 Watlow Heater Control	29

8.6 Image Improvement.....	29
8.7 Top Platen X/Y Adjustment to Maximize Light Through Platens	29
8.8 Camera X/Y Tracking	29
Appendix A. Mechanical Drawings	A-1

DISCLAIMER

This report was prepared as an account of work sponsored by an agency of the United States Government. Neither the United States Government nor any agency thereof, nor any of their employees, makes any warranty, express or implied, or assumes any legal liability or responsibility for the accuracy, completeness, or usefulness of any information, apparatus, product, or process disclosed, or represents that its use would not infringe privately owned rights. Reference herein to any specific commercial product, process, or service by trade name, trademark, manufacturer, or otherwise does not necessarily constitute or imply its endorsement, recommendation, or favoring by the United States Government or any agency thereof. The views and opinions of authors expressed herein do not necessarily state or reflect those of the United States Government or any agency thereof.

1. Project Description

This report describes the system designed and fabricated for the National Center for Advanced Information Component Manufacturing (NCAICM) project number 9322-135. The system is a device capable of simultaneously aligning two glass plates and sealing them together with glass frit.

2. Process

The process development was divided into two phases. The first was thermal sealing in an ambient environment. The second was sealing a controlled environment in a vacuum.

2.1 Phase I - Air Thermal Sealing

The Phase I portion is a system that aligns and seals in air and yet be compatible with a vacuum system that was delayed due to funding constraints. The Phase I design provides vacuum compatibility for subsequent integration of a vacuum chamber, provides alignment and sealing for four different vendors panels (Plasmaco, FED Inc. , SIDT, and Colorry), and provides laser access to the flat panels from four sides.

2.2 Phase II - Vacuum Sealing

The Phase II system is the addition of a vacuum system to the present sealing device. The vacuum system allows vacuum thermal bake-out of the panels at 10^{-6} torr and backfilling the chamber with a specified gas, before the align and seal. Other improvements planned with Phase II funding are described in Section 8.

3. Hardware Description

3.1 Device Description

The National Center for Advanced Information Component Manufacturing (NCAICM) Flat Panel Alignment and Sealing device is shown in the Figure 1 below. The three major sections are the optical system, which includes the standoff microscopes and cameras which are the two dark vertical cylinders on the left, the mechanical components that support the cameras, actuate the lower glass panel, and the Data Acquisition and Control system hardware which occupies the right half of the picture. In operation, a pair of panels is loaded into the system beneath the cameras and the video image of the alignment patterns of both top and bottom panels is monitored by the data acquisition system. Errors in position are calculated based on the images and the bottom glass is repositioned to minimize the error. The panels, along with the sealing glass, are heated, aligned and brought together to form the aligned and sealed unit.



Figure 1. NCAICM Flat Panel Alignment and Sealing System

3.2 Optical System Selection

Sensing the alignment of the glass panels is complicated by the facts that the panels must be held, positioned, heated, and that the final gap separating the two panels may be anywhere from 20 to 2000 microns across. Also, there is no guarantee that the two glass panels will both expand and contract at the same rates during the heating and cooling cycles of the sealing process. Therefore, the alignment system optical hardware and software, must be robust enough to accommodate for the possibility of differential panel growth. The heating, up to over 500 °C, and the vacuum platens themselves force some standoff distance and the panel gap range requires a large depth of focus. All of these facts led Sandia to pursue an image processing based design as well as a laser based design. In the end an image processing based system was chosen primarily because of its robustness and funding constraints did not allow the continued development of two alignment systems.

3.2.1 Optometrix

The Optometrix system used an optical system that focused two squares onto an optical sensor, see Figure 2. In our case one plate moves relative to the other. The Optometrix system was tested using two glass plates with identical squares printed on each. The camera was mounted perpendicular to the face of the glass plates approximately 14 inches away. The glass plates were spaced about 1mm apart, at the time the widest known gap. When the squares were placed over each other the Optometrix system gives an analog output that is proportional to the difference in plate position in both the X and Y direction. Testing the system with different gap spacing yielded sensitivity of about 5mV per micron of displacement with a ± 3 sigma noise level of ± 15 mV, see Figure 3. This proved promising given the results for the standoff distance and separation of the plates, however a visual cue and a differential measurement from nominal was desired. Also, the Optometrix system needs some overlap of the squares to allow the system to work. Because of the thermal growth and different processing of the panels, as defined by the Consortium, overlap of the squares could not be guaranteed. Given those constraints the Optometrix system was not considered suitable.

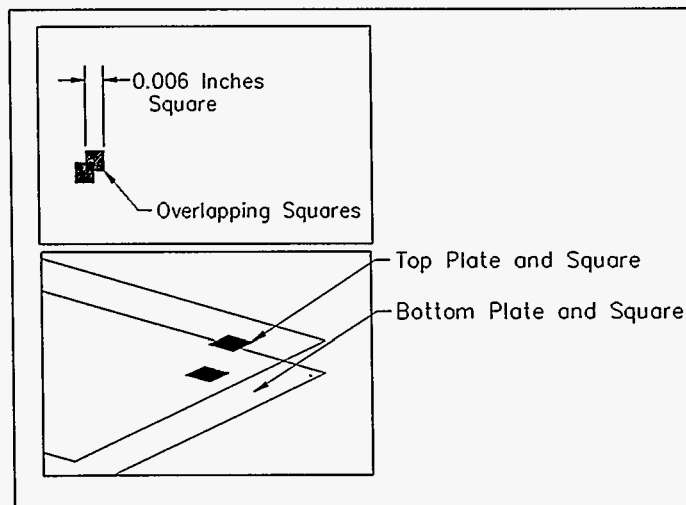

Figure 2. Optometrix Pattern

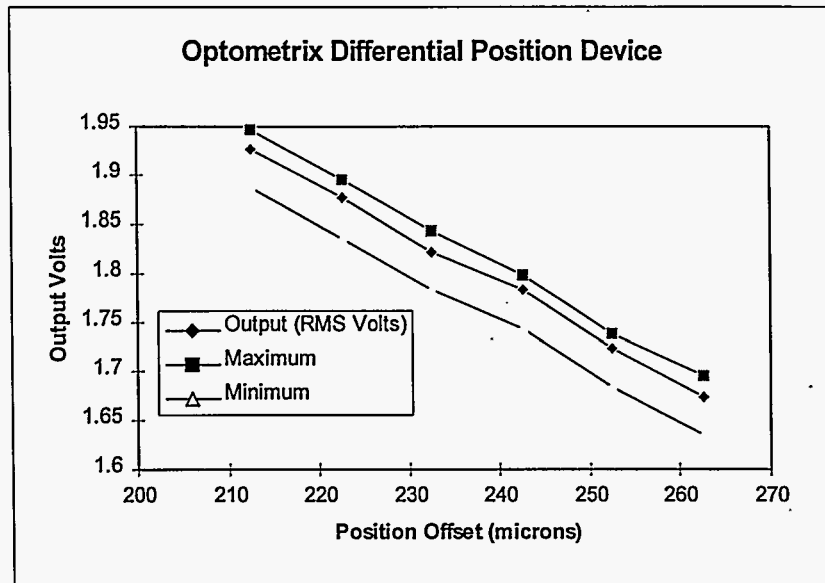

Figure 3. Optometrix System Output Signal

3.2.2 Navitar/Mitutoyo

A video microscopy system considered was the Navitar Ultrazoom mated with a Mitutoyo objective. This system has manual zoom and focus, with optional motorization, and coaxial illumination. The Mitutoyo objectives have a maximum working distance of 33.5mm with a depth of focus approximately 25 microns. Initial testing showed the Navitar/Mitutoyo system to have very sharp images but the working distance was considered too short. The coaxial illumination would eliminate the need for back lighting the alignment marks from beneath the lower platen leaving a bit more room.

3.2.3 Infinity

The Infinity K-2 Long Distance Microscope was selected primarily for its long working distance. With the CF-3 objective its working distance is 4 to 6 inches. This is more than adequate for accommodating the platens, support structure, and remain unaffected by the sealing temperatures. The Infinity systems ordered came with the CF-3 objective, manual aperture, manual zoom control, manual focus control, an orientable c-mount video adapter, and a fixed 2x doubler. Although its depth of focus is also large enough to visually see across the largest of the panel gaps the captured images weren't "clean" enough for the alignment algorithm to process accurately. Back lighting is required as the Infinity doesn't have built in capability for coaxial illumination.

3.2.4 Depth of Field and Resolution Limit

A challenge on this project was not only requiring the optics to give resolution but also maintain a depth of field to image both panels simultaneously. The request for alignment resolution of a micron per inch of panel (later changed to 2 microns minimum), based on a six inch panel inferred at least a micron resolution. If one assumes an average wavelength λ , of 550nm, and a camera aperture ω , of 44.5mm, the angle of minimum separation α is

$$\alpha = \frac{1.22\lambda}{\omega} = 1.51 \times 10^{-5} \text{ rad},$$

given $s = r\alpha$, where r is the standoff distance for the Infinity optics to the alignment marks of 94.7 mm, the minimum separation is $s = 1.43$ microns. Clearly this is the limit and given that the optics are not perfect it indicates that it is at least in the range for the resolution required. The depth of field could be calculated in several ways but since the alignment method uses an area measure of the white and dark

fields, alignment can be accomplished without the optimum focus. To date the best alignment is to within 6 microns, but process limitations have hampered results.

3.2.5 Lighting

As stated previously the Infinity doesn't have coaxial illumination so the alignment marks are back lighted from beneath and imaged from above. The lighting sources for the two sets of alignment marks are two fiber optic light sources. The fiber optics are brought in beneath the bottom platen horizontally and reflected upward through holes in the platens by mirrors set at a 45 degree angle. A diffuser plate was inserted just above the mirror in the Camera 1 system to improve the imaging. Camera 2 has a diffuser in line with the fiber optic bundle and did not require a diffuser at the mirror as was the case for Camera 1.

3.2.6 University of Arizona Alignment Concepts

The University of Arizona Optical Sciences Center was contracted to develop a conceptual design of a laser based alignment algorithm. This was done as a parallel effort to the image processing based effort Sandia was developing. After receipt of the University of Arizona final report it was decided to discontinue pursuit of the laser based alignment concept due to funding constraints. A copy of the University of Arizona Alignment Concept Study is included in the appendices.

3.3 Image Stability (Air Jets)

Heat from the platens increased the surrounding air temperature which changed its index of refraction. This caused the images of the alignment marks to "move" as the heated air rose around the cameras, much like a mirage in the desert, where the heated air near the ground bends the light and presents a reflection of the sky. To reduce the image shift and distortion the air needed to be mixed. Looking at drawing R50679 Flat Panel Alignment Display Assembly, sheet 4 in Appendix A, or the simplified version in Figure 4, you can see the Alignment camera looks down through several parts, the Plate Top (Item 15), the Top Cone (Item 14), the Top Support Plate (Item 11), the Plate Heater Top or Upper Platen (Item 5), and finally on the glass panels that are to be sealed (Items 34 and 35).

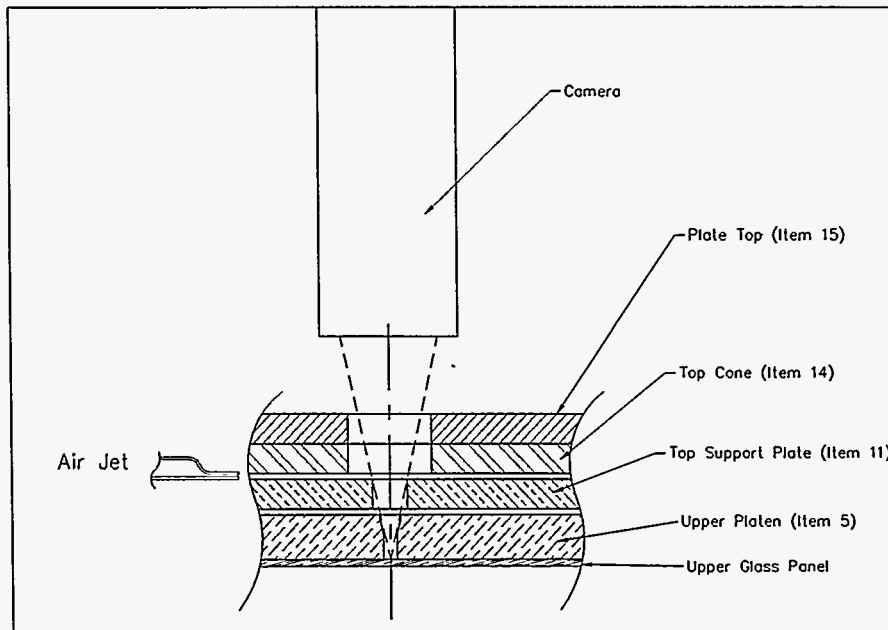

Figure 4. Air Jet Image Stabilization

Since the hottest part of the system is the Platen (Item 5) ranging from 420° C to 550°C, the largest air temperature variation would probably come around it, however, the air above the top glass panel is trapped in the view hole of Item 5. This trapped air did not appear to affect the image to a great extent. Immediately above the Platen (Item 5), is the top support plate. It has a larger viewing port to accommodate the optical access to the alignment mark on the upper flat panel. The top support plate, which is the second hottest component, is thermally isolated from the top platen but still reached temperatures of 190 to 215°C. Since air can circulate around this part much of the image distortion originated from this area. To eliminate the distortion several air mixing methods were tried. First, an air jet inside the support plate view hole with an adjustable angle was tried. A cross hole was drilled to intersect the view hole. A tube with a 0.020 inch orifice was inserted into the cross hole and air could be injected at different angles by rotating the tubing. A matching jet was placed on the opposite side of the view hole. A variety of air pressures and angles were tried but the image did not stabilize. Jets were then placed in the space above the Top Plate (Item 15), and various angles and pressures were tried but did not help.

A rectangular orifice of about 0.040 x 0.50 inches was then tried. Several orientations and positions were tried. The best image results appeared when the orifice was placed between the Top Support Plate (Item 11) and the Top Cone (Item 14), see Figure 4. Tubing was built with an orifice of about 0.040 by 0.40 inches and mounted to allow the air jet to be aimed from above the Support Plate directly at the view port area above the alignment marks.

3.4 Platen Design

The glass panels that are processed and ready for sealing are individually held and heated by platens. The platens are a set of removable plates specific platen to each of the four consortium members flat panel design. A lower platen is shown in Figure 5.

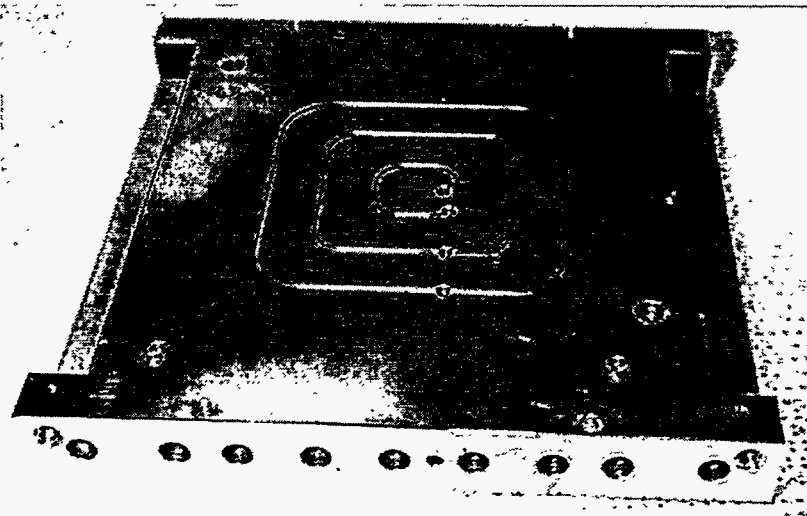

Figure 5. Lower Platen

The platens are held in the sealing machine, via support plates, by springs with a kinematic mount between the platens and support plates. The mount utilizes three ceramic balls in grooves. The ball-in-groove approach allows for differential thermal growth between the heated platen and its support plate, shown in Figure 6.

The ceramic balls provide thermal isolation between the platen and its support plate. The springs are made of Inconel X750 which is capable of handling the high temperature without loss of their spring

characteristics. This platen design allows for future modifications that could make panel removal and reinsertion part of an automatic process.

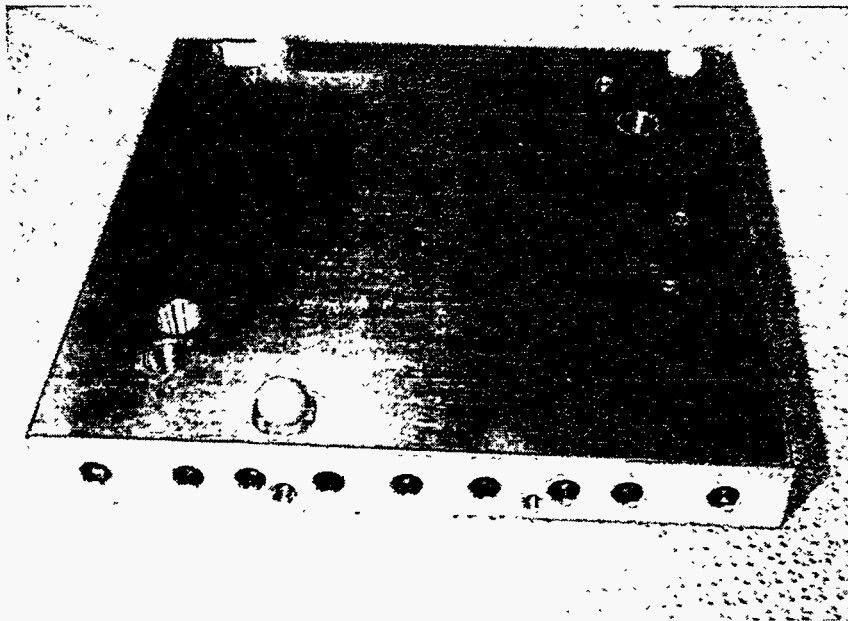

Figure 6. Support Plate with Kinematic Mount

The platens provide several functions. First, they locate the flat panel parts in the machine so the alignment patterns are coarsely located under the cameras to within about 3 mm. This is accomplished by three locator pins extending up from the face of the platen. Second, the parts are held either upside-down by the top platen or securely in place on the lower moving XYZ platen with vacuum porting on the platen surface. A small venturi vacuum system hold the panels against the platens. Third, the platens provide the heating function, bringing the glass up to 450 °C or 515 °C while keeping the glass temperature uniform within about 6 °C from center to the edge. Along the front edge of the platens shown in Figures 5 and 6 numerous holes are visible, these are where 0.25 inch diameter heater rods are inserted to provide the heating function.

The platen's heating function was the primary consideration in the design. The first design considered was a commercial resistive coating on the surface of an alumina platen. This would allow uniform heating, and ability to handle future vacuum capability. The down side of this design was the extreme cost. The simplest pattern would cost on the order of \$8000 for each platen. With the need for 8 platens for the four panel designs \$64,000 was too expensive for the project's budget. A less expensive design included using a much more conductive aluminum plate. Aluminum's conductivity (300 w/mC) is an order of magnitude greater than the alumina. The design was a platen with several heater rods running length wise down the center of a platen. Analysis showed that when heated with heating rods, the alumina had about a 30 °C temperature variation from center to edge on a 6 inch square, while the aluminum was about 6 °C. Watlow, a heater vendor indicated that they could provide a vacuum compatible heater rod. Subsequent inquires revealed Watlow heaters actually had not worked at the 1×10^{-8} torr vacuum level. The Sandia Glass Lab inspected the Watlow heater rods and determined the rods could be sealed making them vacuum compatible to the required levels.

Another development process required for the vacuum platen was mitigation of scratches on the panels caused by the platens. The first panel scratches showed up in a radial pattern from the center of the glass. Although it was known that the aluminum platens would form an aluminum oxide, which in turn scratched the glass, there were other abrasive sources. The radial scratch lines were caused by the difference in

coefficient of thermal expansion between the glass and aluminum. This difference caused the lines to grow out from the center of the glass platen. The high spots on the platens were also a possible cause of the scratches. Figure 7 below shows the scratches on the glass near the "cross" alignment marks. The scratches show up as the bright lines around the clearance hole in the platen. The scratches are in the upper left hand of a test plate and are clearly oriented toward the center of the plate. These scratches were caused by an aluminum oxide on a slightly elevated portion of the platen around the hole.

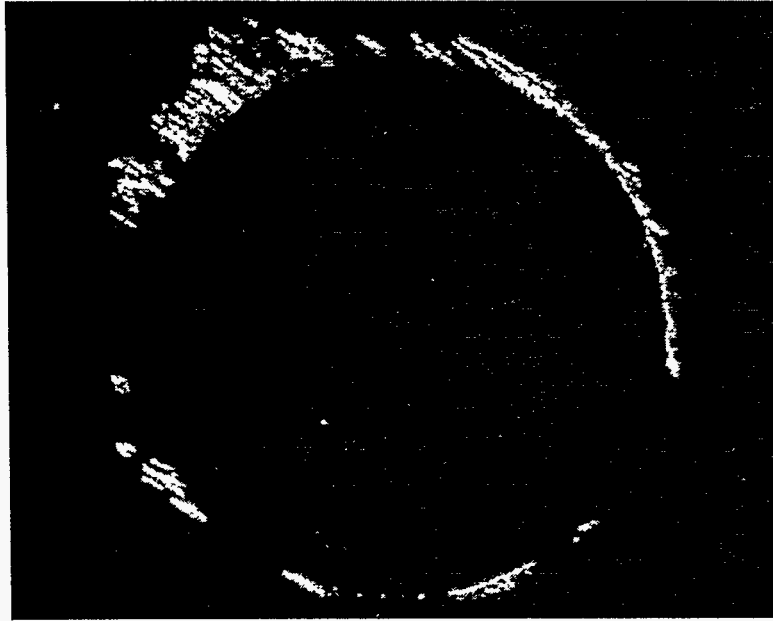

Figure 7. Glass Scratches Around the Platen Aperture

To check out if surface irregularities caused scratches, a platen was lapped flat with a diamond compounds. The platen was reinserted into the test machine with a glass panel and heated. The radial scratch lines were still present with additional heavy scratches. The new heavier scratches were caused by some of the diamonds embedded into the platen during the lapping process, see Figure 8.

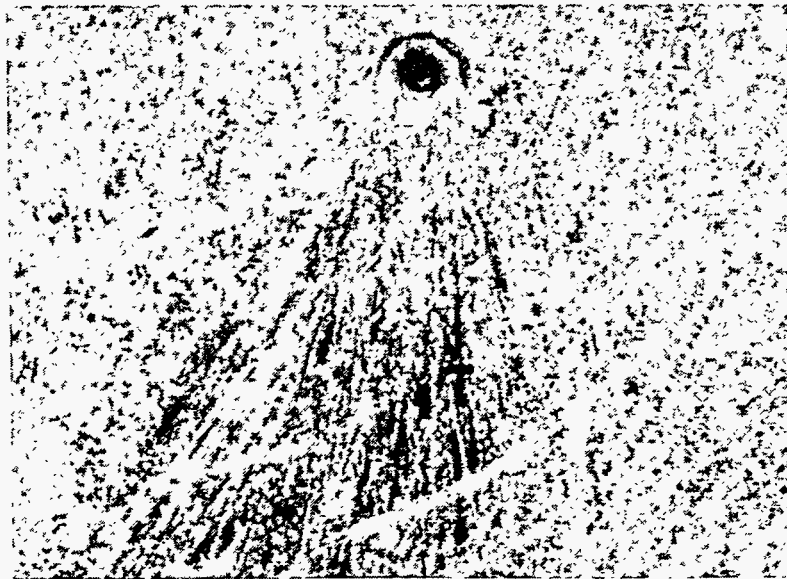

Figure 8. Diamond Embedded in Platen During Lapping

The diamonds were embedded in the platen because the platen was previously heated above the anneal temperature making the platen very soft. This photograph of a platen shows a piece of diamond in the top center that was left embedded in it. The diamond was the coarsest grit used, subsequent finer grits left the comet tail appearance. Because the platen had been heated to above the anneal temperature for 6061 Aluminum and then air cooled it was "soft" and the diamond grit was easily embedded into the platen.

The solution was to remove a layer of aluminum from the platen, including the diamonds, and electrodeposit a layer of chrome. A chrome layer thick enough to stop the aluminum oxide from forming and yet still thin enough to avoid having the difference in thermal coefficient of expansion to cause the chrome to peel off the aluminum platen surface was desired. The final thickness used was about 10000 Angstroms. Thicker coatings, however, may be useful since the current thickness was not very durable. After processing about 40 plates there is some scratching on the platen, however there have been no scratches on the glass. The majority of the scratches on the platen, where the chrome is removed, occurs during the loading and unloading process. Many of the panels tested have had sharp edges, and since the loading is manual, whenever an edge strikes the platen and the chrome is sometimes scraped away. Overall the chrome has solved the problem of scratches on the glass.

The full anneal temperature for the 6061 aluminum used for the platens is 415 °C. Heating the platens to over 500 °C increased the likelihood of platen warpage. If any warpage occurs, the platen may not hold the parts with the venturi vacuum. Measurements before heating the lapped platens to 550 °C showed flatness on a lapped surface to be less than 25.5 microns. After heating, the lapped surface was measured and found to have flatness of 16.25 microns. It should be noted that the post heated measurement does not indicate an improvement of the flatness of the part but rather an indication that the flatness was inside the measurement system limitations. It should also be noted that the kinematic mount springs are located near the ceramic balls to keep the force moments low as possible, and thereby minimize warpage of the platen. Figures 9 and 10 show the platen flatness before and after a thermal cycle.

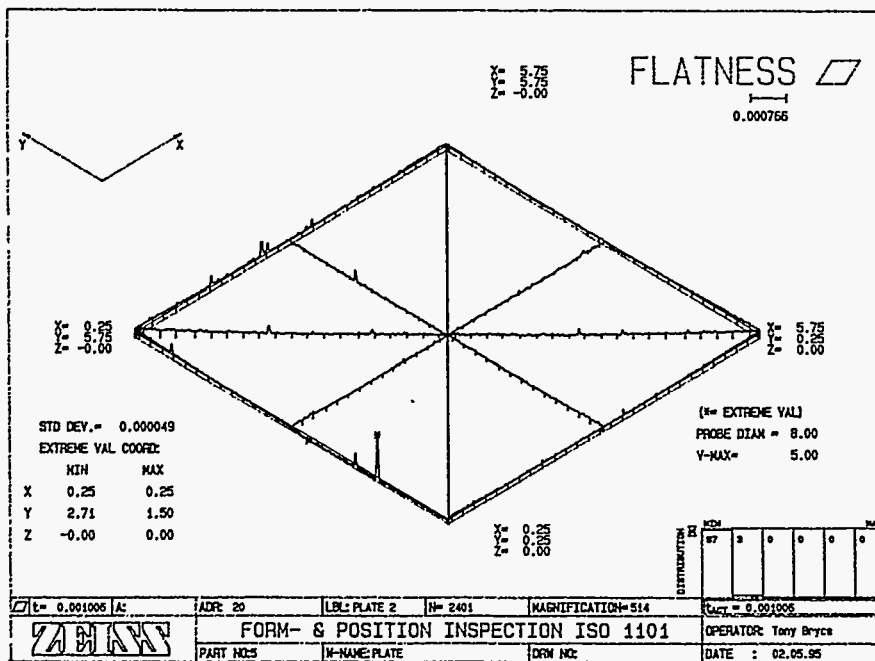

Figure 9. Platen Flatness Before Thermal Cycling

Plate #2 Area 550 Thermal Cycle
25% 135°C/min Cool Over 1hr

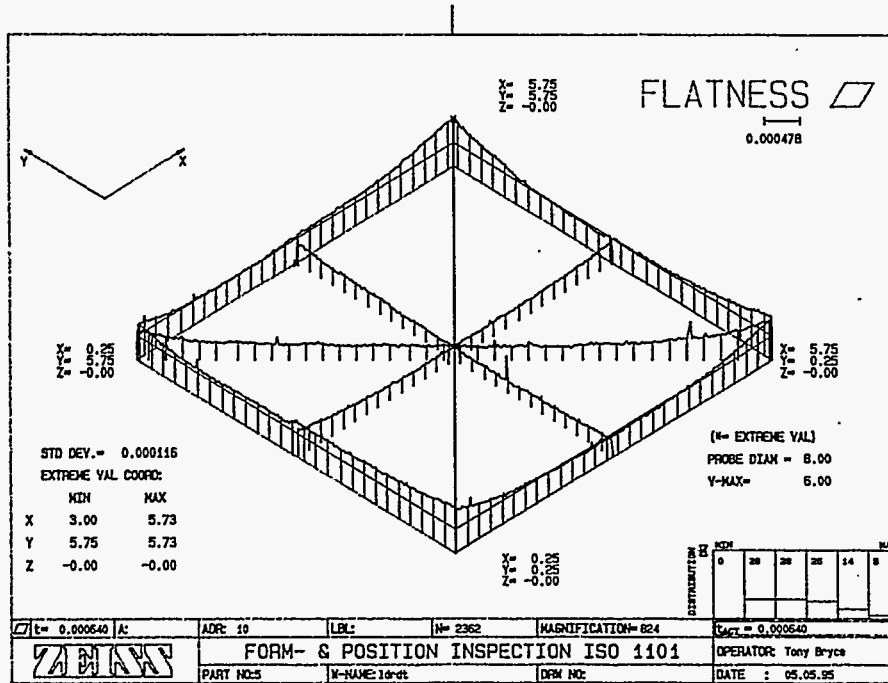

Figure 10. Platen Flatness After Thermal Cycling

3.5 Pneumatics

There are several pneumatic applications in the NCAICM Flat Panel Alignment and Sealing System. The first is the vacuum chuck that holds the flat panel glass in place on both the top and bottom platens. The Pneumatic Schematic (see Figure 11) shows that the platen pneumatic control is selected by two switches. The first switch directs either air or vacuum to the platen. The second switch connects the output from the first switch or a vent to atmospheric pressure to the platen. With these two switches the platens can receive either a vacuum, to hold a part to the platen, air to separate the panel from the platen, or simply a vent that will slowly release a panel from the platen. The air is useful in loading glass on the lower platen because it works like an air bearing on the glass so it can be positioned in place without dragging the panel on the platen. The vacuum is used to hold the flat panels in position so they don't translate in x and y, and in the case of the top platen, to hold the part on the bottom of the top platen. The vent is used after a seal has been made and the system is cooling from the anneal temperature. Switching to vent allows the top platen to slowly separate from the glass as the system cools.

Another application of the pneumatic system is the Soft Stiff braces that stabilize the optics. Since the camera's optics are so large and supported in a vertical manner they easily vibrate when the optical table is bumped or when repositioned by the PM200 controller. A diagonal sliding brace is used to allow motion and yet can be locked to hold the camera mount in place. If air is supplied between the two braces an air bearing is created allowing motion. If air is supplied to the air cylinder it clamps the two surfaces together and stabilizes the camera for gathering video images.

Other functions of the pneumatic system are to provide air to the image stabilization air jets near the camera and the support bellows as described in Section 3.6.4.

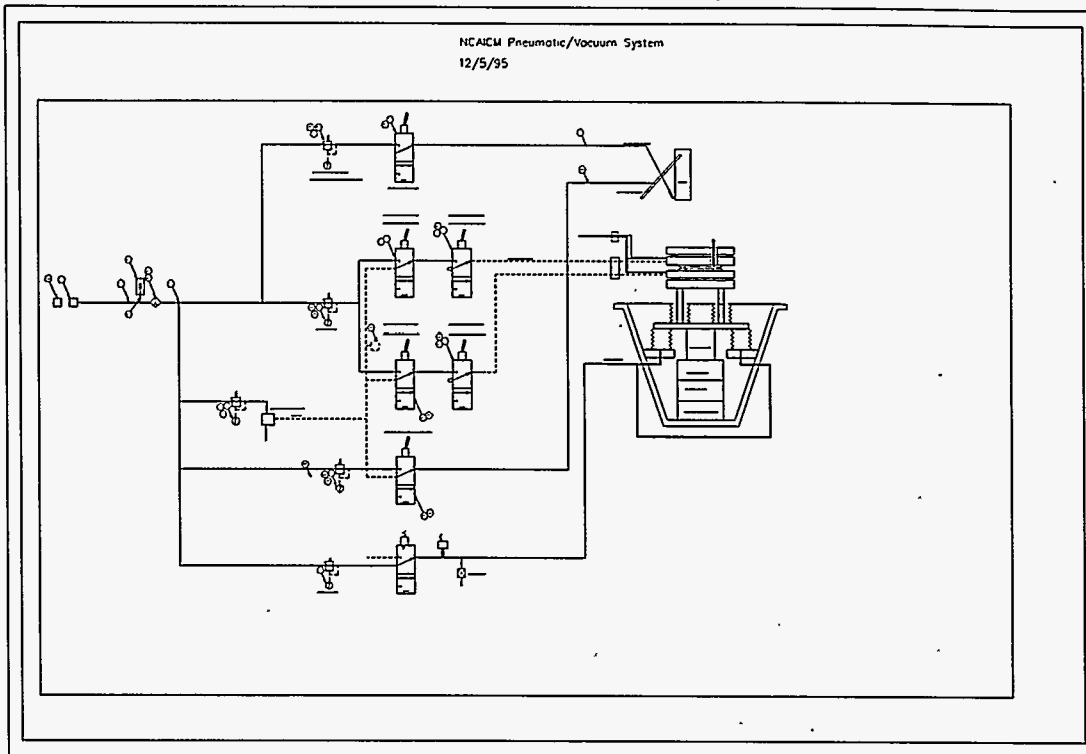

Figure 11. Pneumatic Schematic

3.6 Motion Hardware

3.6.1 Translation/Rotation Stage Selection and Incorporation

A survey was conducted for suitable positioning equipment. Selection criteria were commercial off-the-shelf hardware, high positioning resolution, LabVIEW compatibility, load capacity, and speed. Several suppliers of high resolution stage systems were identified. Systems from Newport, New Focus, and Burleigh were investigated.

The Newport PM-500 series stage equipment (X, Y, Z, and theta stages) was chosen because of its integrated stages and actuators, positioning speed, resolution, existing LabVIEW drivers, and load capacity. The Newport PM-500 stages have direct-drive DC servo-motors with an optical encoder on the drivetrain output. Using Newport's controller with LabVIEW software drivers allowed for quick integration into the system. The stages were ordered with their standard positioning resolution, 100 nm for X & Y, 50 nm for Z and 1 arcsec for theta. Higher resolution is available as an option, but it wasn't necessary for this project. The linear positioning speed of the PM-500 is up to 25 mm/sec, while the New Focus and Burleigh were 1mm/min and 2 mm/sec respectively. The Newport system's load capacity is almost 10 times that of the Burleigh or New Focus. Existing LabVIEW drivers for the Newport system also were available and helped speed along the system integration. The Newport stages are communicated to via a GPIB interface.

3.6.2 PM-200 (Camera Z-axis motion)

The high magnification of the optical system resulted in a shallow depth of field driving the need for automated focusing capability. Different gap depths between the glass panels necessitated imaging on one panel and then "jumping" the gap to image the second. Automating the control of the camera focus ring would have furnished limited depth of field range. To provide vertical positioning to achieve varying

depth of field for each of the 2 cameras the Newport PM-200 2-axis controller system was selected. The controllers drive Newport 850B Series motorized drives integrated on each axis. Using Newport's controller with LabVIEW software drivers allowed for quick integration into the system. Axis initialization, velocity and acceleration control, and positioning requests from the LabVIEW software are sent via GPIB to the controller which instructs the drives. The velocity and acceleration parameters were set very small as not to cause additional vibration. The SCALE factor needed to be defined in order to have the resulting move equal the commanded move for the system. The factor was determined empirically and is saved as a Global variable.

3.6.3 Stage Testing

PM-500 stage components were tested for positional accuracy in the same configuration used in the Flat Panel sealing system. The configuration of the stack up from bottom to top consists of the X linear stage, the Y linear stage, the Theta rotary stage with the Z vertical stage on top. Each axis was actuated with positional accuracy determined to be within 1 micron on 6400 micrometer traverses. The translation error in X and Y of the Z stage actuated over 6400 microns was about 2 microns. The testing was done on a Ziess UPMC 550 whose certified resolution for the range measured is 1 micron.

3.6.4 Bellows Mount for Force Compensation/Rotation

A special design was needed to allow use of the Newport stages with the future vacuum chamber. On the top of the Z stage, a diagonal cross hatch just above item 8, drawing R50679 Appendix A Flat Panel Alignment Display Assembly, sheet 4, is the Plate Adapter (Item 10) that connects the Z stage to the Lower Support Plate (Item 12). Notice the Plate Adapter goes through the bellows assembly (Item 9). These bellows form the seal for the vacuum chamber and allow X, Y, Z and Theta rotation. Since the Newport system can only support about 15 kg., a device was added to offset the weight of the lower platen, the lower support plate, and the Plate Adapter (Item 10). This device, which is actually four more bellows assemblies (Item 9) connected between the lower cone (Item 7) with Bellows Bracket (Item 21) and the Plate Adapter, can also compensate for the extra force that the vacuum system will apply to the bellows when there is a difference in the pressure across the vacuum chamber system. These lower bellows will be maintained at about 6.0 psi above the chamber or atmospheric pressure to offset the weight of the Adapter Plate and platens. The bellows device could also be used to provide extra force to press the glass plates together when the seal is being formed.

3.6.5 Thermal Isolation of the Stages from Temperature Environments

Thermal isolation of the heated platens has several advantages. It minimizes the energy required to heat the system, allows use of low temperature components around the platens, and minimizes thermal growth and related stresses. Figure 12 below shows the Schott type Frit thermal cycle. At about 1500 seconds, the highest temperature is the Bottom Platen, next highest is the Top Platen. The platen temperatures are slightly different because they have separate controllers. The next temperature down is the Top Support Plate which is the mounting plate above the upper platen. The maximum temperature reached on the Top Support Plate was 200°C. The next highest temperature is the Top Camera Plate whose maximum temperature was 36°C was far below the support plate or platens. The graph shows descending temperatures for the Rear Adapter Rods, the Front Adapter Rod and the Vacuum Flange whose temperatures never went above 28°C.

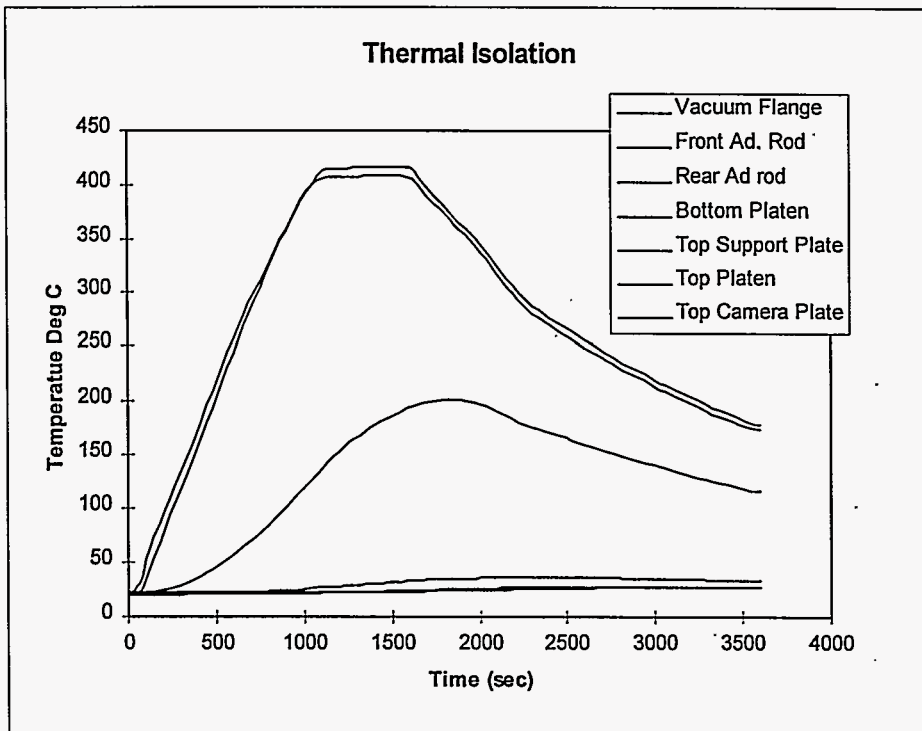

Figure 12. System Component Temperature Profiles

3.6.6 Vibration Isolation

An optical table was specified that would let the device sit in a hole through the middle of the table. Drawing R50679 Appendix A, Flat Panel Alignment Display Assembly, sheet 4 shows where the lower cone (Item 7) sits on the Newport Optics table. This allows the operator to load and unload parts at table level. The table selected is a Newport RS-2000 Sealed Hole Top with Tuned Damping. The long sides on both ends allowed area to mount the lasers that were to be used for laser sealing of panels. The optical table is supported with Newport I-2000 High Performance Laminar Flow Isolation legs that provide passive vibration control.

When the table is floated on its isolation legs any motion of the table is clearly seen by the cameras. The camera motion is compensated for using the soft stiff braces described in Section 3.5. A potential issue remains in that the bottom support for each camera is a slide that is not secured, since during the heating process the alignment marks move due to thermal growth and the cameras must translate to keep the image roughly centered in their field of view for alignment purposes. A potential fix would be a locking device, that would hold the slides securely only during image capture.

4. Data Acquisition and Control System Hardware

Being a technology development project commercial off-the-shelf hardware was selected for use whenever possible. This was done to reduce the time and expense of developing and integrating custom hardware. The data acquisition hardware is responsible for acquiring the images for alignment, force measurements for sensing panel contact, and thermocouple readings for platen temperature monitoring. The alignment images are acquired by a frame grabber board and the force and thermocouple data are acquired by an input/output (I/O) data acquisition (DAQ) board. Force and temperature signals are routed through a front-end analog multiplexer board mounted in a 19 inch rack. The Newport PM-500 platen positioning stage system is communicated via GPIB communications as is the Newport PM-200 camera focusing actuators. All of these boards are hosted in a Pentium based personal computer (PC).

4.1 PC

A Dell 100MHz Intel Pentium PC was selected for the system computer. The PC has 32 Megabytes of RAM, a 1 Gigabyte hard drive, and a PCI bus motherboard. The operating system running is Windows 3.1. The AUTOEXEC.BAT and CONFIG.SYS files, are listed below, to detail the software configuration of the PC.

AUTOEXEC.BAT

```
@SET SCSI_DRIVER = C:\IOMEGA
@SET SCSI_UTILITY = C:\IOMEGA

rem      E:\CORELDRV\CORELCDX

@C:\DOS\MSCDEX.EXE /D:IOMEGACD /L:J
REM C:\DOS\SMARTDRV.EXE /X
C:\DOS\SHARE.EXE /1:500 /f:5100

@ECHO OFF
PROMPT $p$g
SET PATH= E:\WINWORD;E:\WINDOWS;E:\CORELDRV;E:\MSVC\BIN;C:\DOS
SET TEMP=C:\DOS\TEMP

SET INCLUDE=E:\MSVC\INCLUDE;E:\MSVC\MFC\INCLUDE
SET LIB=E:\MSVC\LIB;E:\MSVC\MFC\LIB

rem      Copy WIN.INI and SYSTEM.INI over to c:\WINDOWS for CONTROL HOSTESS
copy e:\windows\win.ini c:\windows\win.ini
copy e:\windows\system.ini c:\windows\system.ini
CD E:
WIN
```

CONFIG.SYS

```
DEVICE=C:\DOS\SETVER.EXE
DEVICE=C:\DOS\HIMEM.SYS
DEVICE=E:\SCSI\ASPI2DOS.SYS /D /Z
DEVICE=E:\SCSI\ASPICD.SYS /D:ASPICD0
DEVICE=E:\CORELDRV\CUNI_ASP.SYS
DEVICE=E:\CORELDRV\UNI_ASP.SYS
device = e:\at-gpib\gpib.com
devicehigh = c:\dos\ramdrive.sys 2048 /e

LASTDRIVE=H
DOS=HIGH
FILES=60
BUFFERS=50
STACKS=9,256
DEVICEHIGH = C:\IOMEGA\ASPIPPA3.SYS Scan Info Busy_Retry Country=001
DEVICE = C:\IOMEGA\SCSICFG.EXE /L=001 /V
DEVICEHIGH = C:\IOMEGA\SCSIDRVR.SYS /L=001
DEVICE = C:\IOMEGA\SCSICD.SYS /D:IOMEGACD
```

4.2 Frame Grabber

A PCI-bus based Meteor frame grabber board from Matrox was selected for the image acquisition because it has significantly faster image acquisition and transfer rates than ISA bus boards and there were no other PCI-bus frame grabbers available at the time. Matrox also supplied C language software libraries with the Meteor board. Sony XC-75 monochrome 1/2" CCD cameras were chosen for the actual imaging. The cameras and board were synchronized so images from both cameras are captured simultaneously. Figure 13 illustrates the camera settings and cabling for the frame grabber and camera setup. Camera 1 is internally synchronized and outputs its sync signal to Camera 2 and the frame grabber board.

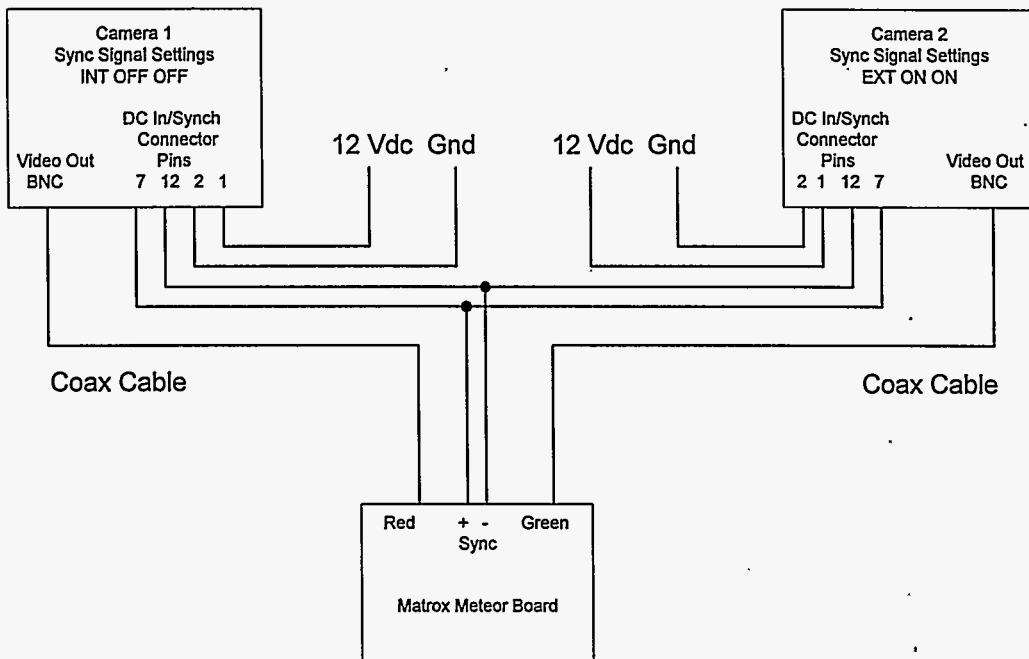

Figure 13. Camera Setting and Cabling Schematic

4.3 National I/O Board

A multifunction I/O board from National Instruments was selected for analog input and digital output requirements. The AT-MIO-16DE-10 is a general purpose plug-in board for ISA bus PCs that include software drivers for Windows 3.1. The board contains 8 differential 12-bit analog inputs with 100kS/s sampling rate, 2 analog outputs, and 32 digital I/O channels. The board has additional features not required by this system. The differential analog inputs are used to read input voltages for force and temperature measurements and both digital and analog outputs for air control to the platens and eventually vacuum system control. The board comes with a set of NI-DAQ software drivers to provide the interface for programming in LabVIEW. The DAQ board hardware configurations are shown in Figure 14.

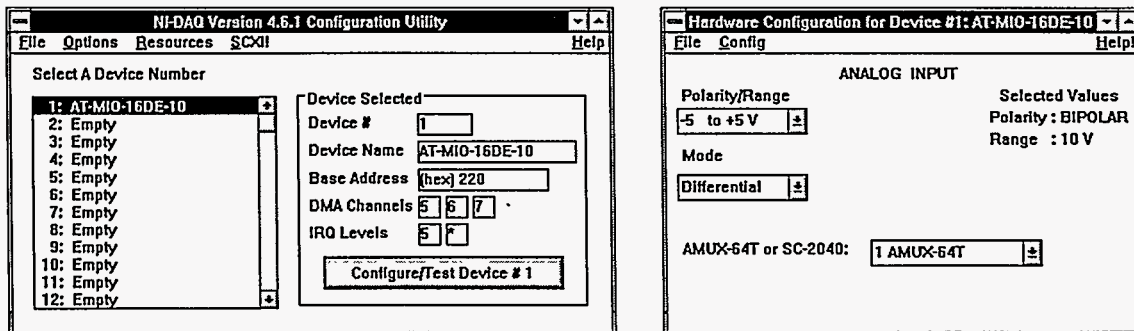

Figure 14. Data Acquisition Board Configuration

4.4 GPIB Communications

A National Instruments AT-GPIB interface board hosted in one of the PC's 16-bit ISA slots and the NI-488.2 software for Windows create an IEEE 488.2 Talker/Listener/Controller that handles GPIB

communications. Standard GPIB cables connect from the board to 2 control instruments, the Newport PM-500 Precision Motion Controller and PM-200 Programmable Motion Controller. Device dependent messages are sent by the GPIB controller to the positioning stages and the camera focusing actuators. A total of 13 instruments can be connected to the bus for future expansion. The GPIB board hardware configurations are shown in Figure 15.

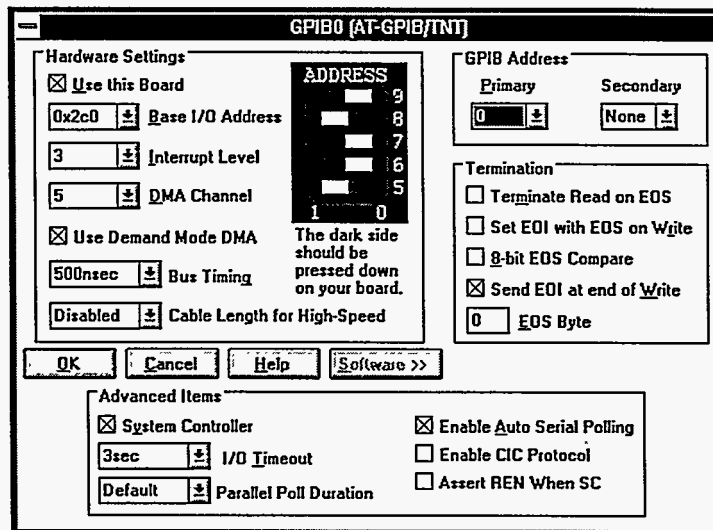

Figure 15. GPIB Configuration.

4.5 Platen Heat Control

The heating control is provided by four Watlow Model 982 heater controllers. A typical thermal cycle for the Schott frit is shown in Figure 16. The temperature starts at 25 °C, ramps up to 430°C at 25°C/minute, holds for 15 minutes and then ramps down to 370°C for a ten minute anneal. The final ramp down is shown as a rate of 20°C /minute but actually occurs at a much slower rate, since the cooling is driven only by air. Cooling to room temperature actually takes about 2 hours. Figure 17 shows the typical thermal cycle for SCB-2 frit. The 982 Watlow controllers take a temperature input from an electrically isolated type K thermocouple that is imbedded at approximately the center of each platen. The thermocouple is inserted into a blind hole so that the thermocouple sits 0.060 inches from the front side of the platen. The controller program runs from setpoint to setpoint with the specified ramprate between each setpoint. The controllers have a PID control loop capability which are tuned for each platen. The controller cycles a 5V output that drives a solid state relay (SSR) switching power to and from the heater rods. To keep the noise down these are zero crossing SSR's. The heaters chosen for the project are Watlow Model EA646 heater rods, a standard 6 in. long, 0.250 in. outer diameter 400 watt heater capable of running at 240 VAC. The heater rods were typically run at 120 VAC, where their actual wattage is about 90 watts. An electrical schematic is shown in Figure 18 showing the wiring of the controllers. Additional wiring was added to allow the future access to the RS232 and analog and digital output of the controllers.

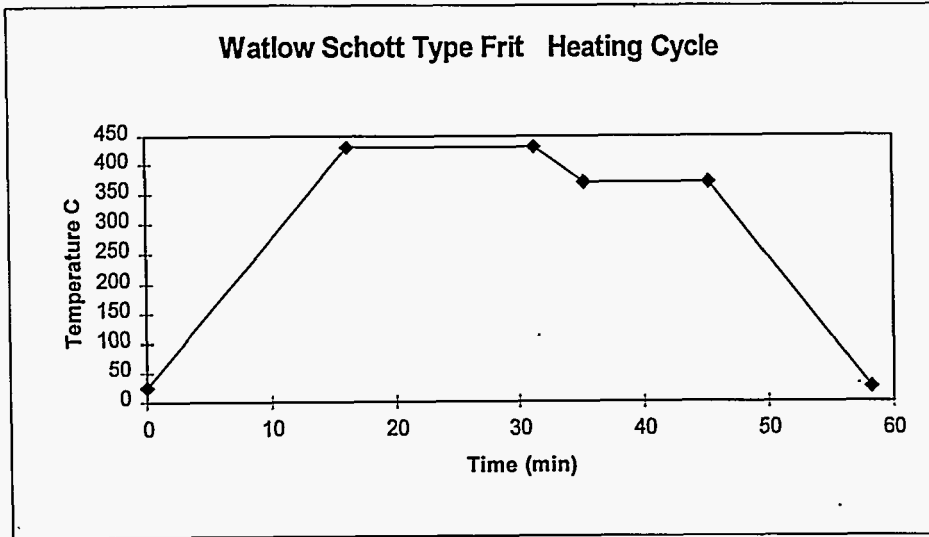

Figure 16. Typical Schott Type Frit Thermal Cycle

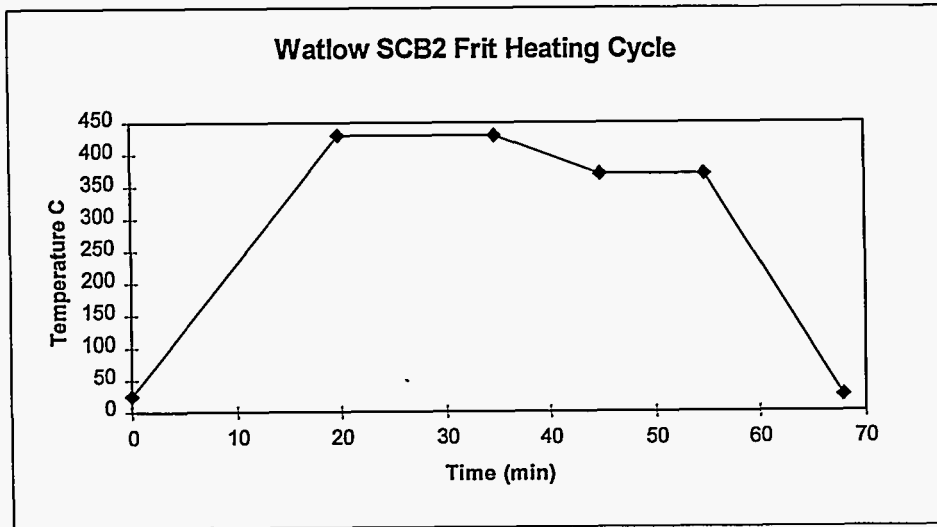

Figure 17. Typical SCB-2 Frit Thermal Cycle

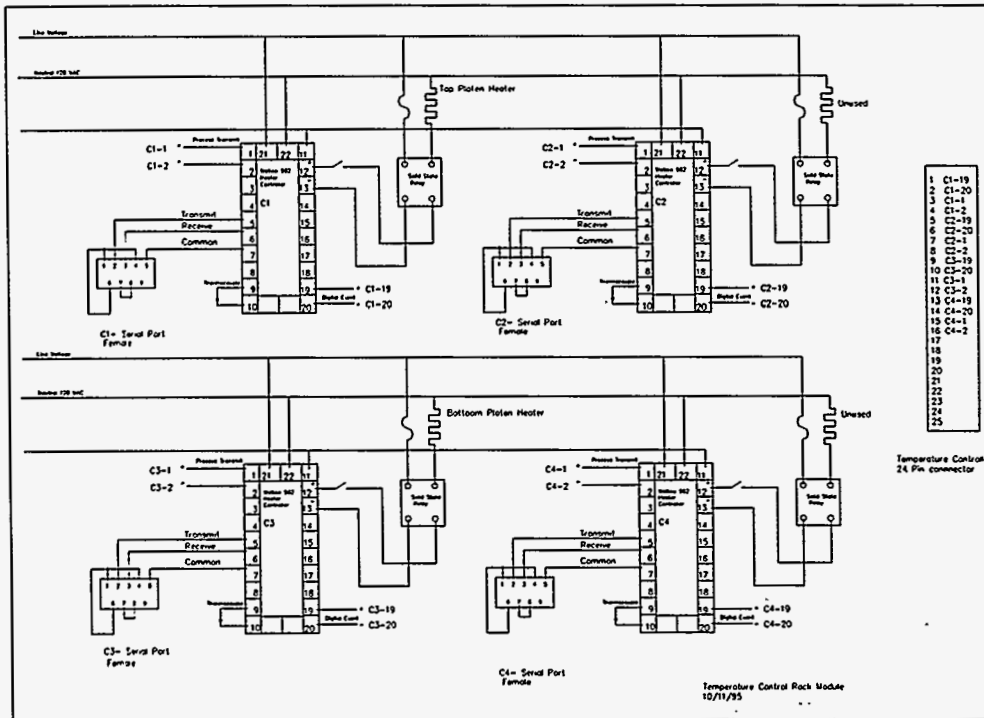

Figure 18. Watlow Controller Schematic

5. Software Description

The control system software is written in two languages LabVIEW-version 3.1.1 and C (Microsoft Visual C/C++ version 1.5), with the C routines called from LabVIEW. The LabVIEW code handles the overall process control, user interface, and non-image based data acquisition. The C code handles the image processing and alignment error determination.

5.1 LabVIEW

LabVIEW for Windows was selected as the Flat Panel software development application because of its functionality and ease of use. LabVIEW is a graphical programming language that relies on graphical symbols rather than textual language to implement programs. LabVIEW programs are called virtual instruments (VI) due to their imitation of actual instruments. Each VI contain an interactive user interface, known as the front panel, and a block diagram, which receives and interprets instructions. One can consider the block diagram as analogous to a function represented by source code. Each VI also has another feature, the connector panel, which allows parameters to be passed between VIs.

Modular programming techniques were used for the flat panel software. Any VI can be used as a sub-VI within the diagram of any other VI. Unlimited number of hierarchical layers can be created. Both custom flat panel specific VIs as well as National Instrument supplied VIs were required to implement the functionality necessary for the flat panel alignment sequence. Application specific libraries for data acquisition, GPIB and serial instrument control, data analysis, data presentation, and data storage are part of the development environment supplied with LabVIEW. The flat panel LabVIEW software program contains well over a 100 VIs. The Sandia developed VIs are contained in the following 15 libraries (LLBs).

CALIBRAT.LLB
DLLNODES.LLB

NCAICM.LLB
PM200.LLB

EXPERMNT.LLB
 IMAGING.LLB
 LOAD_PID.LLB
 MENU.LLB
 MOTION.LLB

PM500.LLB
 PROCESS.LLB
 SEALING.LLB
 SEEKFORC.LLB
 TEMP.LLB
 UTILITY.LLB

5.1.1 User Interface

LabVIEW takes advantage of Microsoft's Windows graphical environment to construct user interfaces. Each VI has a front panel which allows the user to execute each sub-VI by itself for debugging purposes. Under normal operation all of the sub-VI front panels are not displayed during execution so that only top level VIs, those representing the process running, can present pertinent information to the user. For an example of what appears on a front panel see Figure 19.

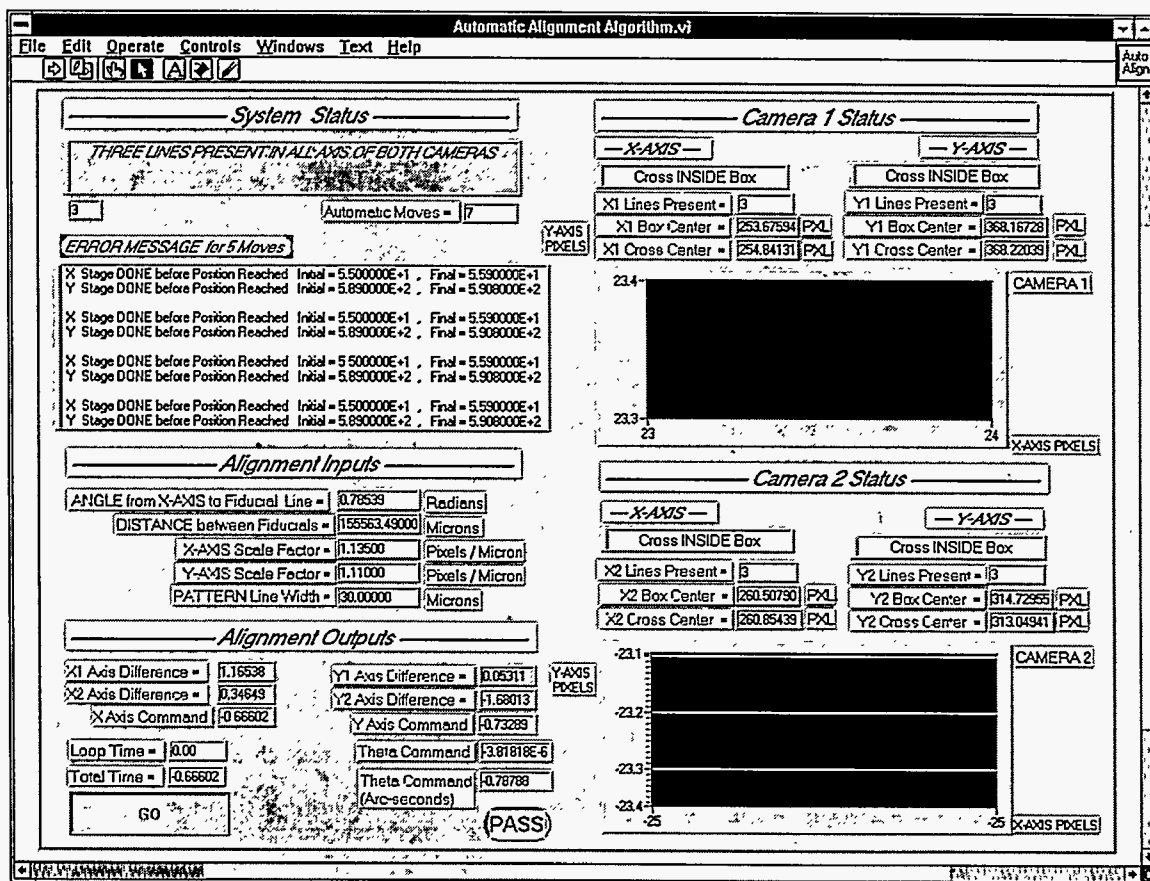

Figure 19. Automatic Alignment Front Panel

The front panel software is a menu based system. Operators can select from the top level menu which can be started by launching LabVIEW and then running the START NCAICM MENU.VI located in the PROCESS.LLB library. The menu presents various options including functions that perform initialization of the positioning stages or GPIB communications, automatic focusing, manual moves, temperature and force monitoring, and scale factor calibration. There are also processes that will perform automatic alignment or system tests. Lastly, there are sequences of functions and processes that include everything in the proper sequence to perform an align and seal.

5.1.2 Process Control

Process control is accomplished through automated system functionality in conjunction with a knowledgeable test operator using confirmed test techniques. The process starts during the setup phase where panel preparation and loading techniques are executed by an experienced test operator. This precedes the phase of the process where the automation which is implemented with the C code and LabVIEW software commences. During the process the test operator needs to have some interaction for inputting some test parameters and error recovery responses.

Once started, the automated portion of the process control depends on either a time expiration, force fluctuation, or temperature level trigger for continuation to the next step. Trip levels for sealing and annealing temperatures, process times, sealing force, and other criteria are stored as global variables or are requested from the test operator. Complete details of the automatic alignment and sealing process are too comprehensive to be represented here.

5.2 Alignment Simulation and Error Equations

An alignment simulation was written using MATLAB for the development of the position error equations for aligning the two panels in X, Y, and Theta. The simulation only simulated the alignment of two panels with respect to each other, no other process activities were included.

The alignment marks chosen were crosses on the top panel and boxes on the bottom, the bottom panel is actuated in X, Y, and Theta. In the MATLAB simulation, the crosses were on the bottom panel and boxes on top panel, this just reversed the sign of the commands. The alignment errors are generated by determining the positions of each cross and each box in the captured images. Knowing the nominal distance, R, from cross to cross on one panel and the aspect angle, Φ , error equations were generated. The MATLAB simulation tracked the positions of each alignment mark and using the error equations removed the error when the "loop" was closed via simulated motion of the bottom panel.

The X and Y errors are the averages of the difference between each box/cross pair center location.

$$X_{\text{error}} = \frac{(X_1 - X_2) + (X_3 - X_4)}{2}$$
$$Y_{\text{error}} = \frac{(Y_1 - Y_2) + (Y_3 - Y_4)}{2}$$

The Theta error is only slightly more complicated. Using small angle approximations, X and Y errors for each image are generated, see Figure 20:

$$\Delta X_1 = R_1 \ominus \cos \Phi$$
$$\Delta Y_1 = R_1 \ominus \cos \Phi$$
$$\Delta X_2 = R_2 \ominus \cos \Phi$$
$$\Delta Y_2 = R_2 \ominus \cos \Phi$$

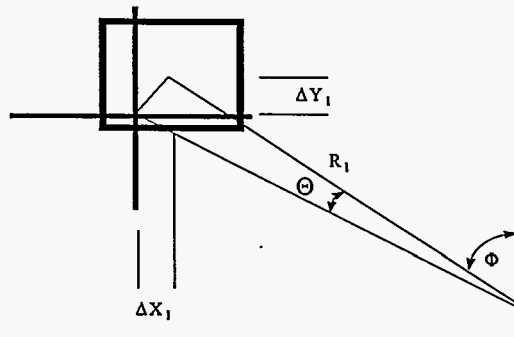

Figure 20. Small Angle Approximation for X & Y Displacements

where R_1 is the distance from the center of rotation to the cross in image 1 and R_2 is the distance from the center of rotation to the cross in image 2, where $R=R_1+R_2$. Adding the terms from above together and grouping

$$\Delta X_1 + \Delta Y_1 + \Delta X_2 + \Delta Y_2 = (R_1 + R_2)\Theta(\cos \Phi + \sin \Phi)$$

Solving for Θ

$$\Theta_{\text{error}} = \frac{\Delta X_1 + \Delta Y_1 + \Delta X_2 + \Delta Y_2}{(R_1 + R_2)(\cos \Phi + \sin \Phi)} = \frac{\Delta X_1 + \Delta Y_1 + \Delta X_2 + \Delta Y_2}{R(\cos \Phi + \sin \Phi)}$$

where, from Figure 21,

$$\begin{aligned} \Delta X_1 &= X_1 - X_2 & \Delta Y_1 &= Y_1 - Y_2 \\ \Delta X_2 &= X_3 - X_4 & \Delta Y_2 &= Y_3 - Y_4 \end{aligned}$$

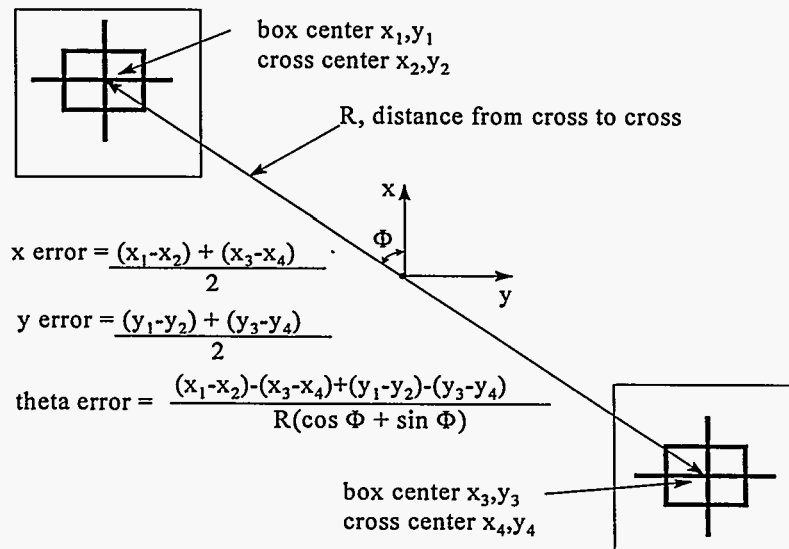

Figure 21. Alignment Error Equations

5.3 Alignment Mark Selection

The alignment marks for the Sandia Test panels, SIDT panels, and FED panels are shown below in Figure 22. The FED alignment marks are different because their specifications were needed prior to alignment mark testing. The alignment marks were settled on after imaging and alignment tests were conducted on panels with a set of five marks of varied sizes and line widths. The five sets were designed after initial imaging test were conducted, but the final marks were chosen only after alignment tests were conducted on the actual alignment and sealing device. Alignment mark selection was deemed premature as the lighting, focusing, and image amplification wasn't fully known until the entire device was built and imaging using the optics and exact lighting conditions could be accomplished. Amplification predominantly determined the mark's height and width with focus affecting the line width.

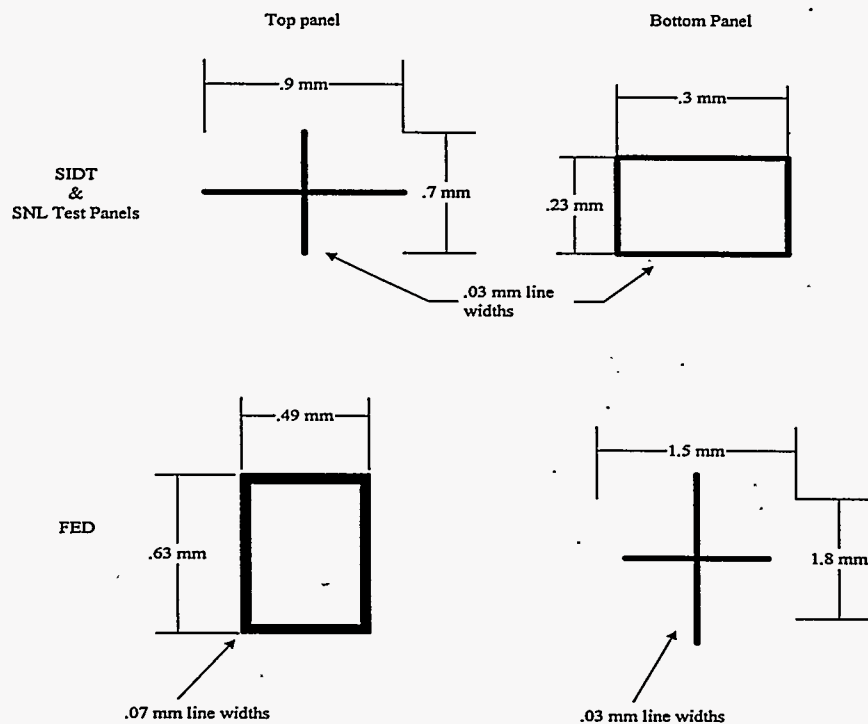

Figure 22. Alignment Marks (not to scale)

5.4 C Code

The C routines are responsible for capturing and processing the alignment mark images and generating the position commands which are passed back to the LabVIEW code for execution. The code is contained in three routines; `edg&algn`, `edge_err`, and `findcntrs`. LabVIEW calls `edg&algn`, which calls `edge_err`, which in turn calls `findcntrs`.

The function `edg&algn` main tasks are to interface with the LabVIEW code and grab and process the images. Strictly speaking the image processing is handled by calls to the Matrox Imaging Library (version 2.15) functions that were supplied with the Matrox Meteor frame grabber board. These calls included functions to allocate memory space for the images and buffers, simultaneously grabbing the images from both cameras as a single image, splitting the image into two separate buffers (one for each camera), smoothing the images, row and column projection of each image, and releasing image memory space and buffers. The interfacing with the LabVIEW code consists of passing data back and forth. The LabVIEW code sends alignment mark characteristics and scale factors, and is returned data for display, diagnostics and position commands. The data consists of box/cross locations, image profiles, status, and commands for stage movement.

The function `edge_err` takes the images and generates a row and column projection. These are arrays containing the sum of the vertical columns and horizontal rows of each image, see example shown in Figure 23. The function `findcntrs` is then called to determine the box and cross locations.

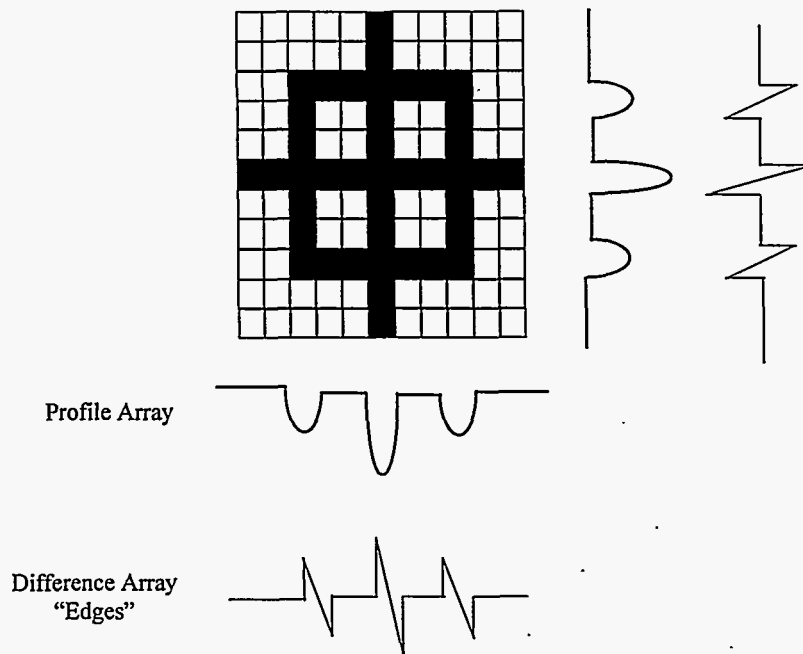

Figure 23. Row and Column Profile of Box/Cross Image

Prior to finding the box and cross centers the edges are enhanced by generating an array of differences for each row and column profile, that is the difference array is equal to:

$$y(i) = x(i) - x(i + 1)$$

where x is a column or row profile. This yields arrays containing the locations of the edges of the boxes and crosses. Using simple threshold checking the edges are located in the images and then the center locations of the lines that make up the box and cross can be found. The center of the lines are found by determining their center of gravity as measured from edge to edge, see Figure 24. Knowing that the crosses will have the largest sum of pixels, because of their longer length, the lines that form the crosses can be distinguished from the lines that form the boxes. Once the box and cross locations are determined the alignment errors are computed, as described earlier, and passed back to the LabVIEW code for stage motion commands.

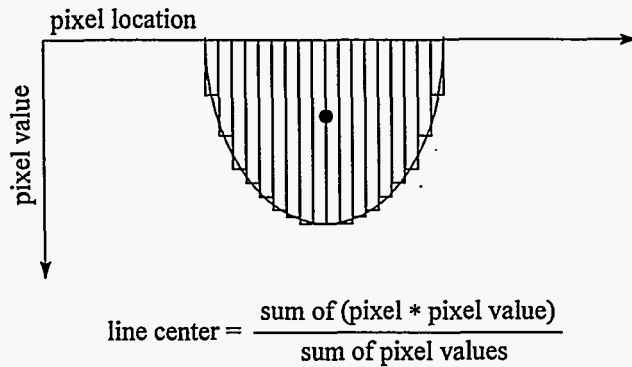

Figure 24. Finding center of lines

6. Process Development

6.1 Early Thermal Sealing (gap jump)

Early experimenting with thermal sealing yielded a simple but effective sealing technique. If a rectangular cross section of frit material is heated to above its melting point, the shape of the frit becomes taller assuming a circular cross section, it's minimum energy form. Holding glass plates apart with fixed spacers with the gap above the Schott frit, approximately 75 microns, the frit "balled up", touched, then wet the top glass surface and created a seal upon cooling, see Figure 25. A cross sectional view of a seal created by this technique is shown in Figure 26. This technique along with alignment using the leveling spring method described in Section 8.3 maybe developed as a process for sealing with the future funding.

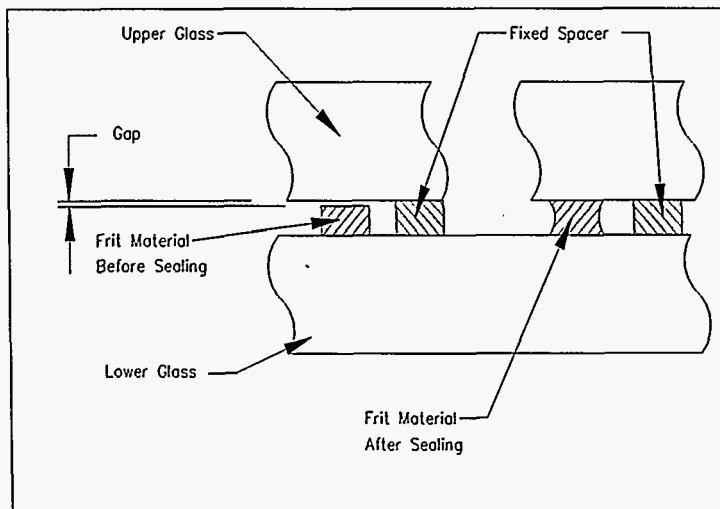

Figure 25. Gap Jump Technique

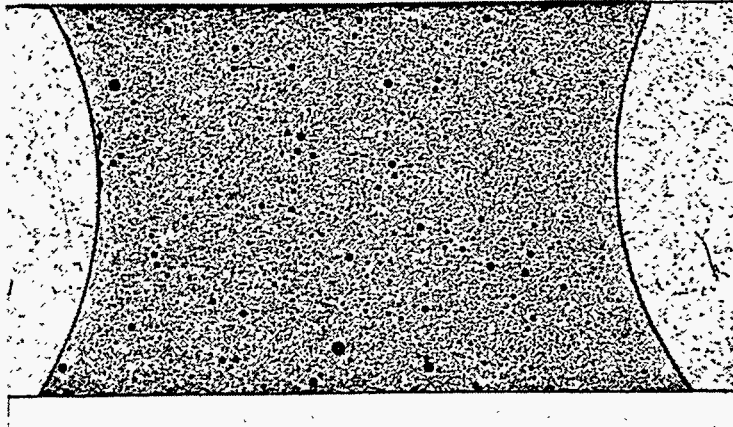

Figure 26. Gap Jump Frit Seal

6.2 Aligning by Squishing Plasmaco Furnished Schott Frit

Once it was decided that the wicking method wouldn't work for all cases an alternative method of aligning and sealing using the same frit was developed. This method utilized the inherent viscous qualities of the Schott frit rods supplied by Plasmaco, Inc. The "squish" method consists of bringing the bottom panel, with the frit on it, into contact with the top panel when the panels have reached approximately 415 °C. The bottom is raised until approximately 13lbs. of force is applied (note there is an approximate 6.5 lb. pre-load on the system) and that position, not force, is maintained. As the frit melts, the force drops off to 7.5-8lbs. and an alignment is then attempted. After the alignment is completed the bottom panel is raised again until 13lbs. of force is applied and it's position maintained. As the frit melts and the force drops off to 7.5-8lbs. another alignment is attempted. This cycle is repeated for approximately 10 minutes. At the end of this time a final alignment is attempted, if the force is sufficiently low. Then the bottom panel is raised until the force reaches 13lbs. and this force is maintained until the anneal portion of the thermal cycle is completed. A plot of the force illustrating this technique is shown in Figure 27. Note that the force reads increasing force as negative due to the sensor's orientation. Also note that the platens were brought together after the thermal expansion of the platen/system had ended. The thermal expansion of the present system is about 1 micron per °C, between the upper and lower platen surfaces.

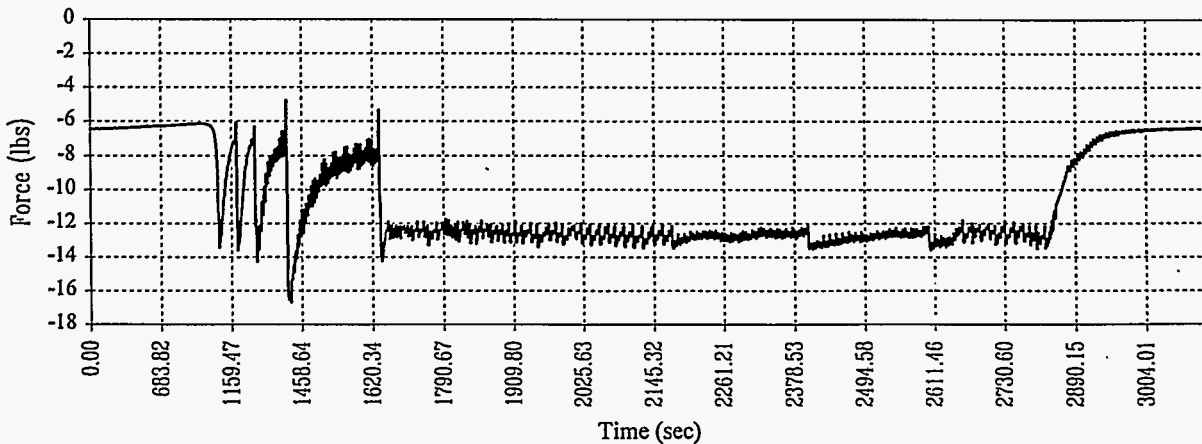

Figure 27. Force on Glass Panels

This method worked fairly well but alignment of the Sandia test panels were approximately 5-6 microns off at best. An image of alignment marks from a sealed set is shown in Figure 28, refer to Figure 22 for dimensions. There are two reasons for the misalignment. The main reason for the misalignment is that if the force between the panels drop to too low a level, about 1 lb., the panels are no longer parallel and the alignment error is increased due to the non-parallelism. In other words the panels must be parallel to one another to get a true alignment error determination. If an alignment is attempted without the panels being parallel and then as the panels are brought together and the panels become parallel the alignment marks move relative to one another.

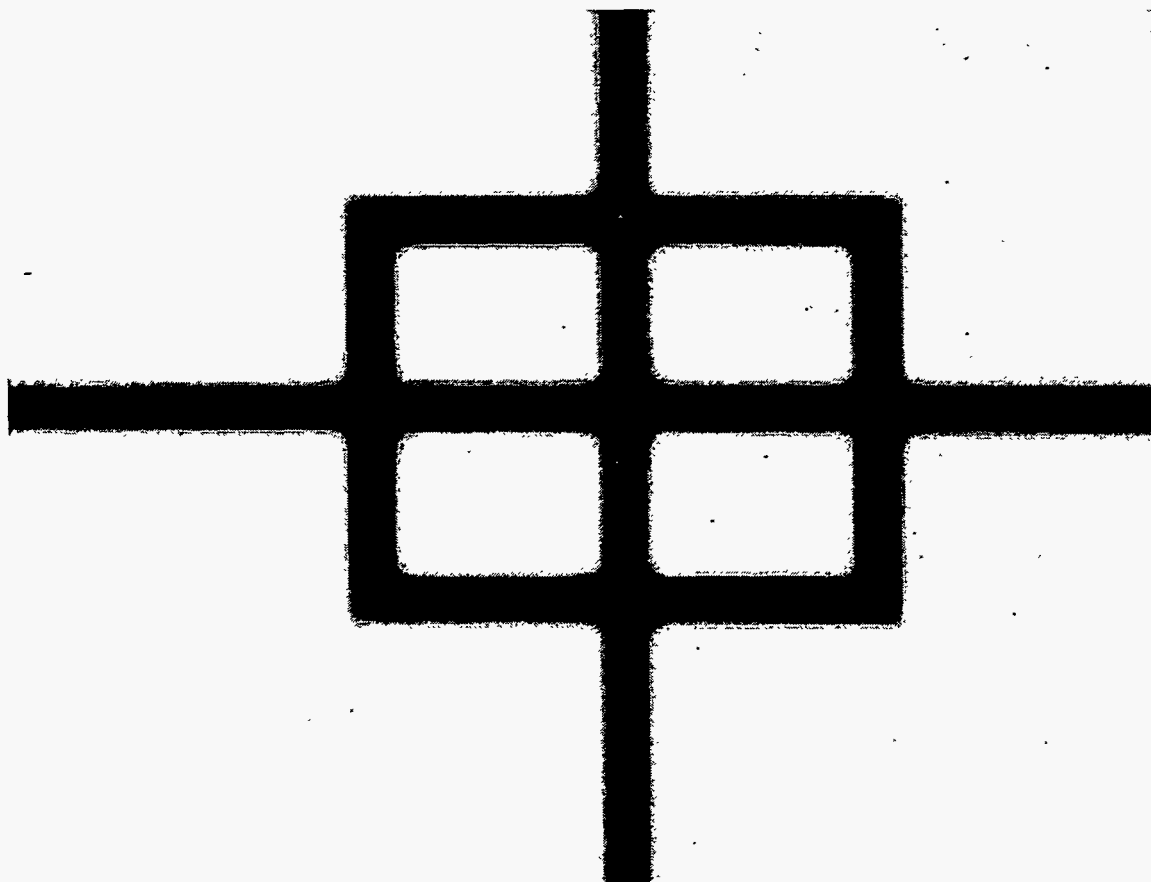

Figure 28. Alignment Image from 1/19/96 Sandia Test Panel Schott Frit Seal

The other reason is that the total range of theta motion is limited to about 300 arcsec by the bellows beneath the bottom platen. If the accumulated theta command ever exceeds the 300 arcsec, which it often does, the torque from the bellows overcomes the theta stage and the bottom platen springs back some indeterminate amount in theta and the theta stage servo continues to try to execute the last command until it is reset.

6.3 Imaging Across Gap Greater Than Optics Depth of Field

The gap remaining after the panels have been aligned is dictated by the spacers inserted between the panels. This gap varies according to the design of the flat panels. The separation between alignment marks on the panels after insertion is greater than this final gap so no damage occurs to the panels during the initial alignment. If the system optics can view both alignment marks simultaneously, the boxes on the bottom plate and the crosses on the top plate, then the cameras do not need moved. However, if the gap is greater than the optics depth of field, approximately 1 mm, then the PM200 camera focusing actuators

must be used to reposition the cameras. The alignment sequence would differ by the fact that after focusing on the bottom plate and grabbing an image, both cameras would need to be moved some predetermined distance to refocus on the top plate. Once both images are obtained, the rest of the sealing process is the same. The distance the cameras move is determined prior to beginning by the test operator following instructions presented on the screen.

7. Testing & Results

7.1 Plasmaco Furnished Schott Frit Rod Sealing Tests

Several tests of the device using Plasmaco furnished Schott frit rods, blank glass panels, and the Sandia test panels were conducted in December 1995 and January 1996. Table 1 lists the results from each test. The testing was conducted using the squish method described in Section 6.2.

In short, seals in the 10^{-9} torr range were achieved but the desired gap spacing wasn't achieved for each test. This was most likely caused by the oxidation of the copper material used for spacers. Tests of the spacers material showed approximately 20 micron expansion due to oxidation. The best alignment achieved was 5-6 microns. This was due to the limitations with the squish method, see Section 6.2, and with the theta range, Section 8.2. In late January it was announced that Plasmaco was no longer an official member of the consortium so testing was switched temporarily from the Schott frit to the SEM-COM SCB-2 frit.

Date	Test Type	Soak Time (mins)	Spacer Height (μm)	Measured Gap (μm)	Init. Contact Temperature ($^{\circ}\text{C}$)	Measured Vacuum (torr)	Notes
12/18/95	Seal	10	75	125-150	390	2.6×10^{-9}	Heater controller PID needs tuning.
12/19/95	Seal	10	75	125-150	390	$<1 \times 10^{-9}$	390 too low, 1 st relax slow
12/20/95	Seal	10	75	125	400	1.8×10^{-9}	Change vertical step size during squish
1/3/96	Align & Seal	10	75	175	400	seal cracked	Force hold software error, 400 too low
1/4/96	Align & Seal	10	75	150	415	not on spacers	Increase soak time
1/5/96	Seal	15	75	125	415	$.5 \times 10^{-9}$	Force release temperature too high
1/9/96	Seal	15	75	75-100	415	$<1 \times 10^{-9}$	Gap largest near tubulation cutout
1/19/96	Align & Seal	15	75	125-150	415	no seal	Force sensor problems
4/17/96	Align & Seal	15	75	n/a	415	no seal	Alignment failed due to theta limitation and frit covered marks
4/18/96	Align & Seal	15	75	n/a	415	no seal	Alignment failed due to poor image & stage problem
4/20/96	Align & Seal	15	75	n/a	415	no seal	Final alignment didn't occur due to software error

Table 1. Plasmaco Furnished Schott Frit Rod Test Results

7.2 SCB-2 Sealing Tests

Testing of SCB-2 screen printable paste and extruded glass rod centered on determining the appropriate screen print thickness of SCB-2 for a good seal and determining if the squish and relax method was applicable. Table 2 list the results from each test. The initial contact temperature for all tests, except the 12/20/95 test at 440 °C, was 495 °C. The only tests to show frit relaxation were the tests with small SCB-2 glass rod pieces in the four corners, 1/18/96 and 4/11/96 tests. The screen print only seemed to compress with no relaxation. Using the glass rods over the entire seal area required more force than the stages are capable of producing.

The results of the testing were that 75 microns of screen print frit must be present for a good seal and the squish/relax alignment method isn't applicable to SCB-2. Both of these points are important because the large gap panels from FED Corp. require the combination of the screen print and glass rod to seal.

Date	Test Type	Frit Height (µm)	Spacer Height (µm)	Measured Gap (µm)	Measured Vacuum (torr)	Notes
12/20/95	Screen print seal	75	38	38-50	$<1 \times 10^{-9}$	No frit relaxation, bubbles in frit
12/21/95	Screen print seal	75	38	38	leaked	No frit relaxation
1/18/96	Glass relaxation	1168	none	38-75	n/a	Small glass pieces in corners, showed relaxation, i.e. squish/relaxation cycle
3/14/96	Screen print seal	84-159	38	74	n/a	no hole in panel to measure vacuum
3/15/96	Screen print seal	69-137	38	58-61	1.2×10^{-9}	Added foil around platens
3/19/96	Screen print and glass seal	74-134	38	45	1×10^{-10}	.178mm SCB-2 glass in corners
3/28/96	Screen print and glass seal	23-64	none	38-45	leaked	1.2mm SCB-2 glass in corners, stage problems
4/2/96	Screen print and glass seal	74-140	1180	1160	1×10^{-9}	1.2mm glass rod on top of screen print
4/3/96	Screen print seal	16-29	none	25-28	leaked	sealed but eventually broke
4/11/96	Screen print and glass seal	44-84	none	41-51	leaked	1.2mm glass on corners showed relaxation, released upper platen vacuum late

Table 2. SCB-2 Frit Test Results

7.3 Ferro Sealing Tests

Two sealing tests of Ferro FX11-120 frit in screen print form were conducted also. The frit height was 65-85 microns for each test, one without spacers and one with 38 micron spacers. No seal was achieved in either test. Because the FX11-120 frit had similar properties as the SCB-2 and funding was low it was decided to continue using the SCB-2 and not investigate the FX11-120 any further.

7.4 FED Corporation Small Panel Testing

Testing using 5 small panels supplied by the FED Corporation was also conducted. In all cases either alignment marks were obscured or the gap was too large to focus on both the top and bottom alignment marks simultaneously. Therefore, there were no computer controlled alignments, all alignments were completed under manual control using the PM-500 stage system keypad controller. During the testing the theta range limitation described in Section 6.2 inhibited the alignment. Visual inspection of the seals indicated good seals. However, the panels were not leaked tested at Sandia before they were returned to FED Corporation. One point of interest was that the maximum temperature, for the Schott frit, was increased to 450 °C in order to melt the tubulation frit ring. Test results are shown in Table 3.

Date	Frit Type	Spacer Height (mm)	Notes
4/24/96	SCB-2 Screen Print + Rod	1.3	Camera 2 alignment marks obscured
4/25/96 A	Schott pre-melted	1	Alignment marks partially obscured, max. temp need to be 450
4/25/96 B	Schott pre-melted	2.3	Gap too large for optics manually aligned
4/26/96 A	Schott pre-melted	2.3	Gap too large for optics manually aligned
4/26/96 B	Schott pre-melted	2.3	Gap too large & particle in FOV. Phosphor plate cracked upon removal from device.

Table 3. FED Corp. Small Panel Testing

8. Improvements

Several improvements to the design of the system were thought of during the course of this project. This section outlines several of them. The improvements in Sections 8.1 - 8.5 will be implemented during the DARPA funded follow-on project. The remaining improvements will be implemented as time and budget allows.

8.1 Proportional Force Feedback

Using the force signal as proportional feedback will yield smoother force curves and prevent overshooting that can occur when using a deadband controller as the system initial was programmed. By using the force signal as continuous feedback this application VI must run in a time share mode with the main LabVIEW process program. To accomplish time sharing this VI needs to be started prior to its use so it runs in the back ground until needed.

8.2 Theta Rotation

The one drawback of the Newport stages is that the output torque of the theta stage (5 in-oz) is too low to overcome the vacuum bellows rotational stiffness, about 100 in-oz. Therefore the system is presently limited to about 300 arcsec of theta motion. The theta range of motion will be increased by actuating the upper platen in theta, this is funded by the follow-on funding from DARPA.

8.3 Spring Method of Platen Leveling

As noted in Section 6.2 a cause of misalignment were the platens not being parallel prior to final alignment. With the top and bottom panels very close to each other, but not touching, a final alignment is performed to correct for X, Y, and Theta rotation. If the panels are in contact the motion of the bottom plate will rotate the top plate, and differential motion could cause damage to flat panels. Recall that the top

plate is capable of rotating in two rotational degrees of freedom, theta X and theta Y. While bringing the two parts together with the final Z axis move, the top panel is free to rotate about theta X and theta Y if the two plates are not parallel.

To eliminate this problem a concept was designed that would help make the platens and glass panels parallel to each other and still allow the X, Y, and theta Z motions to occur. Vertical compression springs were installed in each corner of the platen that were matched for spring rate and length. As the lower platen moves toward the upper platen the springs touch before the glass panels contact and rotate the upper platen parallel to the bottom platen. At this point the springs still allow about 0.050 inches of compression before the panels touch. This small amount of movement translates to a linear force increase that can be monitored and used to trigger setpoints for alignment.

8.4 Pneumatic Controls

Automation of the pneumatic controls will be included in the next phase of this project. The present valves that are manual will be converted to computer controlled using solenoid valves. This will aid in the panel loading and unloading and during image capture with control of air jets and soft stiff braces.

8.5 Watlow Heater Control

Temperature profiles will be downloaded from the LabVIEW controller program via the serial port. This replaces manual programming of the heaters.

8.6 Image Improvement

There are a couple of ways the imaging may be improved. One improvement would be to use the Navitar Ultrazoom lens system, if the 33mm standoff distance isn't too short, the short 25 micron depth of focus can be accommodated, see Section 6.3, and performance of the optics in the actual device is as good as it was in the initial open air testing. The lighting of the present system may can be optimized with the help of an optical engineer's input.

Image can be improved with more precise location of the air jets under the top cone. This will eliminate the current tubing that is routed under the top cone. The new jets will introduce air in a more symmetrical manner to avoid inducing rotation on the top platen assembly.

8.7 Top Platen X/Y Adjustment to Maximize Light Through Platens

In the design of the Flat Panel machine the top platen is free to rotate in theta X, and theta Y, and fixed in X, Y, Z, and theta Z. In constraining the top platen's position, there isn't any adjustment for error in the location of the alignment marks on the top platen. This design relied on the alignment marks located within a true position tolerance zone of 2mm on the panels, but this was not the case for all of the parts. For the parts out of specification the cameras were moved to find the alignment marks, which caused the camera to look down the side of the viewing ports. This created illumination problems as well as imaging problems. If funding is available a pair of translation stages will be added to move the top pivot in the X and Y directions.

8.8 Camera X/Y Tracking

During the thermal cycle the glass panels expand and contract due to their thermal growth and contraction. Presently, the alignment marks are kept in the center of the field of view by manually adjusting the position stages that hold the imaging optics. An improvement to automatically track the alignment marks and keep them in the center of the camera's field of view would be a valuable and easy improvement. Actuating the position stages using the locations of the alignment marks as feedback would fully automate the tracking of

the alignment marks as they expand and contract. This can be accomplished simply by adding actuators to the optics stages, e.g. Newport 850-F Series, and modifying the LabVIEW code to drive the actuators based on the alignment mark locations already being returned from the alignment routine.

Appendix A. Mechanical Drawings

D

C

B

A

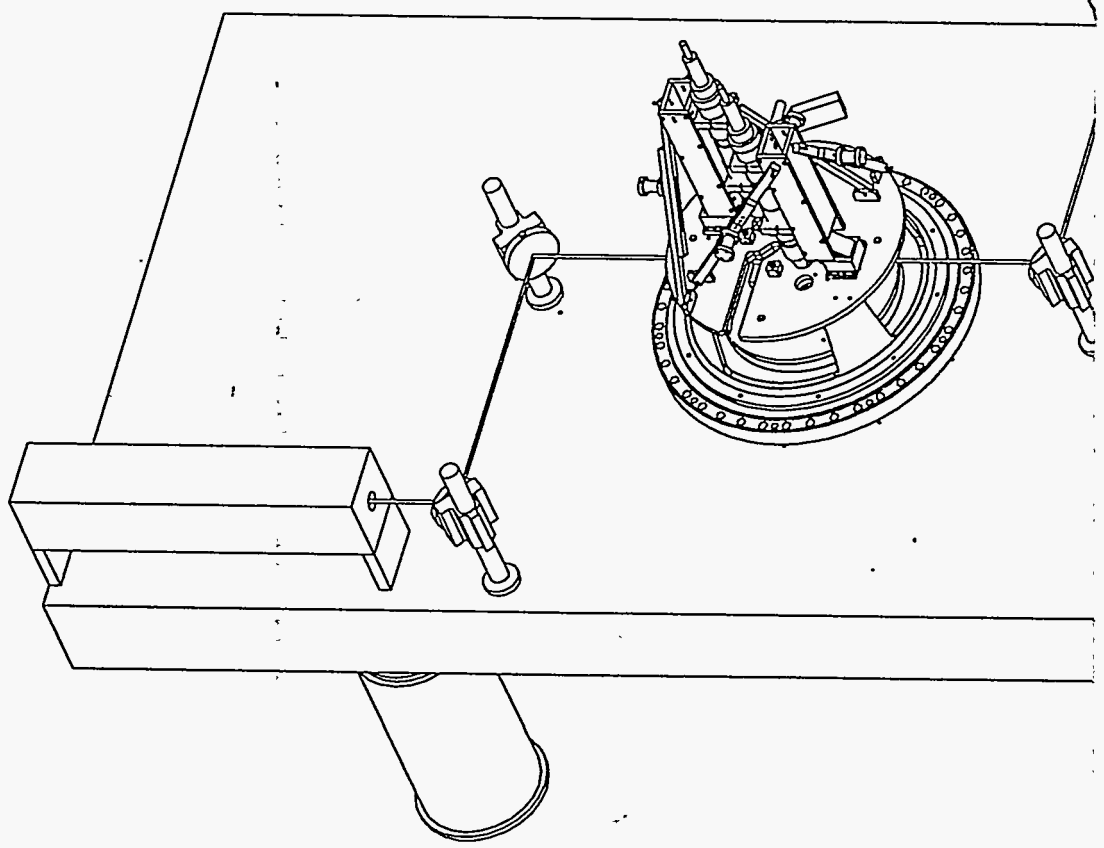

1. THIS DRAWING CONTAINS ONLY THE SANDIA GENERATED PARTS AND DRAWING CALLOUTS. ALL COMMERCIAL PARTS AND HARDWARE HAVE BEEN DOCUMENTED WITH ENGINEERING ORGANIZATION 1484.
2. ALTERNATE HEATER PLATIS TO BE USED BASED ON THE GLASS APPLICATION THAT IS BEING SEALED. CAMERA AND BRACES MUST BE LOCATED ACCORDINGLY.
3. REFERENCE DRAWINGS ARE PROVIDED AS GUIDE FOR SUB-ASSEMBLIES USED TO ASSEMBLE THE MACHINE.
4. REFERENCE DRAWINGS ARE PROVIDED AS GUIDE FOR VARIOUS GLASS OPTIONS.

PART NUMBER		PREPARED BY		DESCRIPTION	DATE	CHEK	APVD
R50679-000		T. WISELEY, 8783 / P. STROMBERG, 1484			06/07/98		PGS

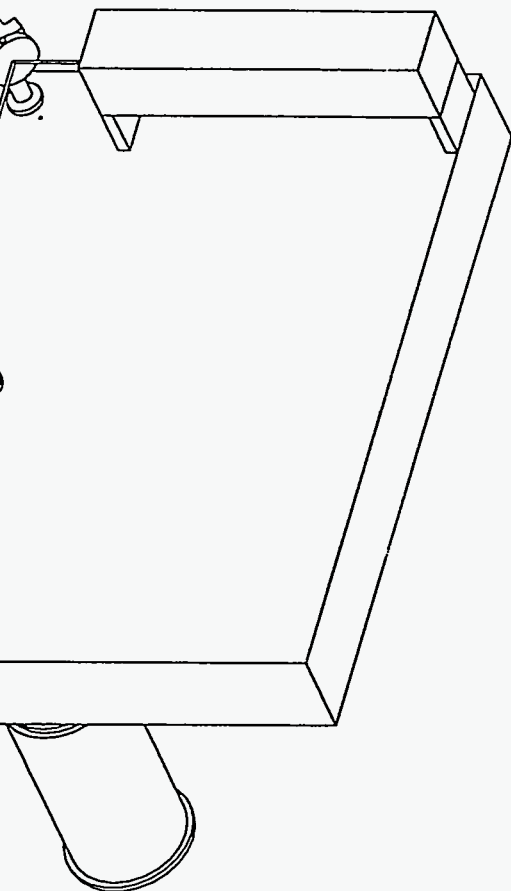

REF	R50678-000	TOP & BOTTOM CONE SUB-ASSEMBLY MCAICM	3	52
I	R50677-000	BRACKET, OFFSET, ANTI-ROTATION		51
I	R50676-000	ANTI-ROTATION ASSEMBLY		50
AE	R48636-000	PIN, SPRING, EXTRA LONG		48
REF	R48635-100	FED DISPLAY 2	4	48
8	R49283-000	BRACE, CAMERA, PIVOT		47
4	R49282-000	BRACE, CAMERA, BLOCK, BASE		46
4	R49281-000	BRACE, CAMERA, BOTTOM		45
4	R49280-000	BRACE, CAMERA, TOP		44
ALT	R49040-000	PLATE, SUPPORT, HEATER, BOTTOM, PLASMACO	2	43
ALT	R49039-000	PLATE, SUPPORT, HEATER, TOP, PLASMACO	2	42
ALT	R49038-000	PLATE, HEATER, BOTTOM, COLORAY	2	41
ALT	R49037-000	PLATE, HEATER, TOP, COLORAY	2	40
REF	R49036-000	PLATE, HEATER, SUPPORT, TOP, DUAL TUBULATION	4	39
ALT	R49035-000	PLATE, HEATER, BOTTOM, SIDT	2	38
ALT	R49034-000	PLATE, HEATER, TOP, SIDT	2	37
REF	R49033-000	COLORAY DISPLAY, FIDUCIAL LOCATION	4	36
I	R49031-000	PLATE, TOP, CROSSES		35
I	R49030-000	PLATE, BOTTOM, CROSSES		34
ALT	R49019-000	PLATE, HEATER, BOTTOM, COLORAY	2	33
ALT	R49018-000	PLATE, HEATER, TOP, COLORAY	2	32
ALT	R49017-000	PLATE, HEATER, BOTTOM, FED	2	31
ALT	R49016-000	PLATE, HEATER, TOP, FED	2	30
ALT	R49015-000	PLATE, HEATER, BOTTOM, PLASMACO	2	29
ALT	R49014-000	PLATE, HEATER, TOP, PLASMACO	2	28
I	R49004-000	DEVICE, ANTI-ROTATION		27
PH	R49003-000	BLOCK, CAMERA		26
2	R48909-000	STIFFENER CAMERA SOT ASSEMBLY		25
PH	R48908-000	GLASS INSTALLER FOR ASSEMBLY		24
PH	R48591-000	FIXTURE, POST TO TOP RAT		23
I	R48566-000	BALL MOUNT, TOP CONE		22
4	PE0367-000	ASSEMBLY, BRACKET, BELLOW, EQUALIZER		21
2	PE0353-000	MOUNT, BACK LIGHT		20
AA	PE0352-000	PIN, SPRING		19
2	PE0351-000	SPRING HEIGHT ADJUSTER ASSEMBLY		18
4	PE0350-000	BRACKET, INFINITY MICRO		17
2	PE0349-000	ADAPTER PLATE, INFINITY MICRO		16
I	PE0348-000	PLATE, TOP, TOP CONE		15
I	PE0347-000	CONE, TOP		14
I	PE0342-000	BASE, VACUUM FLANGE, 27.125		13
I	PE0341-000	PLATE, SUPPORT, HEATER, BOTTOM		12
I	PE0340-000	PLATE, SUPPORT, HEATER, TOP		11
I	PE0339-000	PLATE, ADAPTER, TRANSLATOR TO BELLOW		10
6	PE0338-000	BELLOW ASSEMBLY		9
I	PE0337-000	PLATE, ADAPTER, TRANSLATOR MOUNT		8
I	PE0336-000	CONE, BOTTOM, TRANSLATOR MOUNT		7
I	PE0329-000	PLATE, HEATER, BOTTOM, TEST		6
I	PE0328-000	PLATE, HEATER, TOP, TEST		5
R1	PE0288-000	VACUUM DIAGRAM, FLAT PANEL DISPLAY ALIGNMENT SYSTEM		4
REF	PE0265-000	PLASMACO DISPLAY, FIDUCIAL LOCATIONS	4	3
REF	PE0264-000	FED DISPLAY, FIDUCIAL LOCATIONS	4	2
REF	PE0263-000	SIDT DISPLAY, FIDUCIAL LOCATIONS	4	1

X1	0018100	MARKING, GENERAL METHODS		
K1	0000000	GENERAL REQUIREMENTS		
NC		PART/CONTROL NO.	DESCRIPTION/MATERIAL	NOTE SHEET ITEM
REQ				ZONE
ALT-ALTERNATE	AS-AS REQ'D	AS-AS REQ'D PER ASSY	EN-EXPENSE MATERIAL	SA-DOCUMENT
				PN-PROCESS MATERIAL
SHEET	1	2	3	4
	5	6		
TITLE				
FLAT PANEL ALIGNMENT DISPLAY ASSEMBLY (U) (MCAICM)				
PART CLASSIFICATION UNCLASSIFIED				
DRAWING CLASSIFICATION UNCLASSIFIED				
SIZE DRAWING NUMBER E R50679				
CAGEC14213 SCALE: 2.00 SHEET 1 OF 5				
STATUS SA-REL-7-24-96 ORIGIN SA-PRO-R15.D				

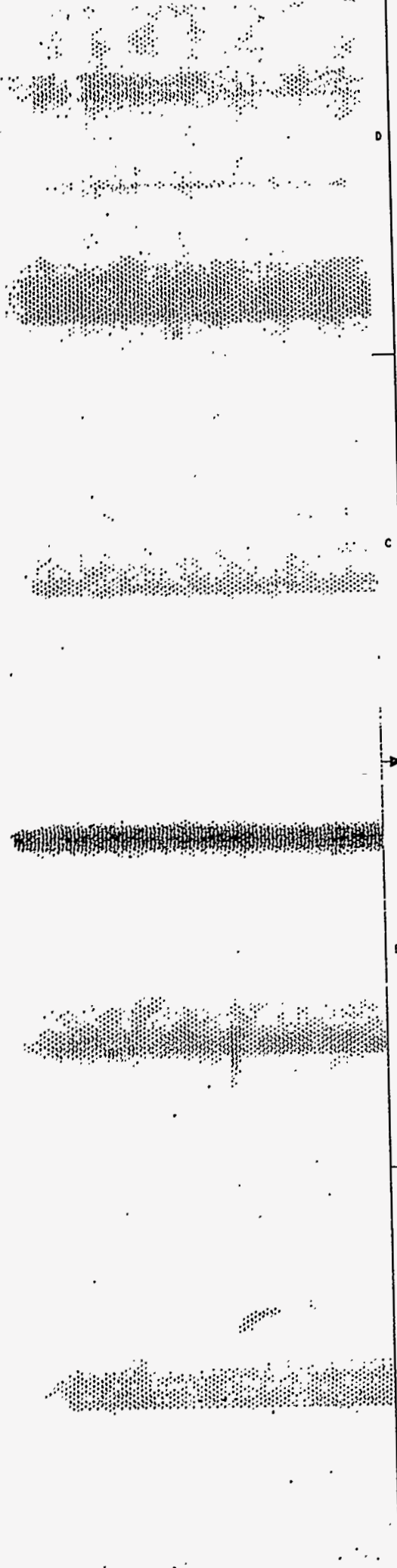

NEWPORT RS1000-58-B
WITH FOUR 22 INCH LEGS

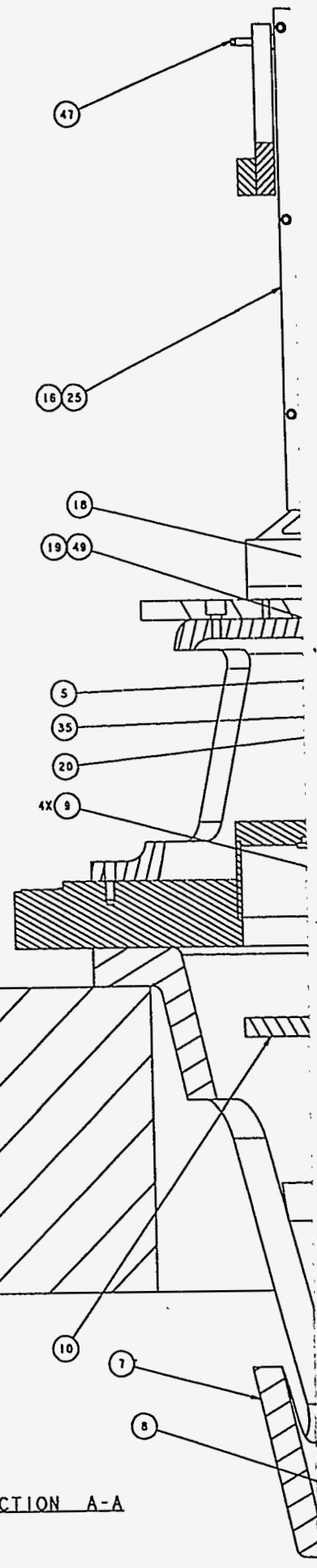

SECTION A-A

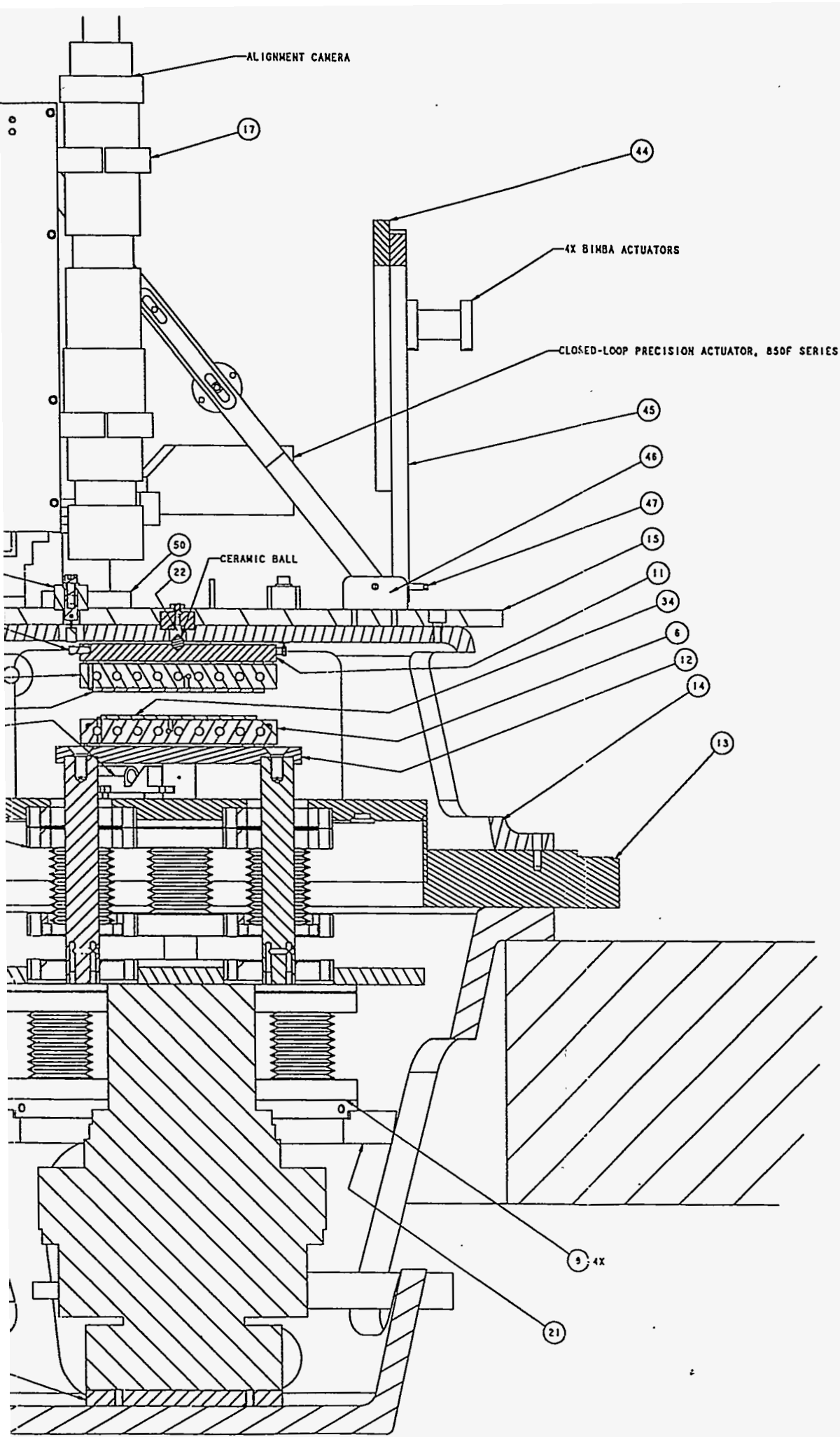

DRAWING NUMBER	
R50679	
DRAWING CLASSIFICATION	
UNCLASSIFIED	
SIZE	CAMEX14213 SCALE 0.750
E	ISSUE A SHEET 4 OF 5
STATUS SA-REL-7-JUN-88	

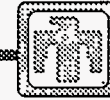

Vacuum Considerations in Sealing Flat Panel Displays

Peter Stromberg

Mechanical Process Engineering Department
Sandia National Laboratory

J. D. Jordan

Guidance and Control Department
Sandia National Laboratory

Larry Kovacic

Ceramic and Glass Processing Department
Sandia National Laboratory

This work was supported by the United States
Department of Energy under Contract
DE-AC04-94AL85000.
Sandia is a multiprogram laboratory operated by
Sandia Corporation, a Lockheed Martin Company,
for the United States Department of Energy.

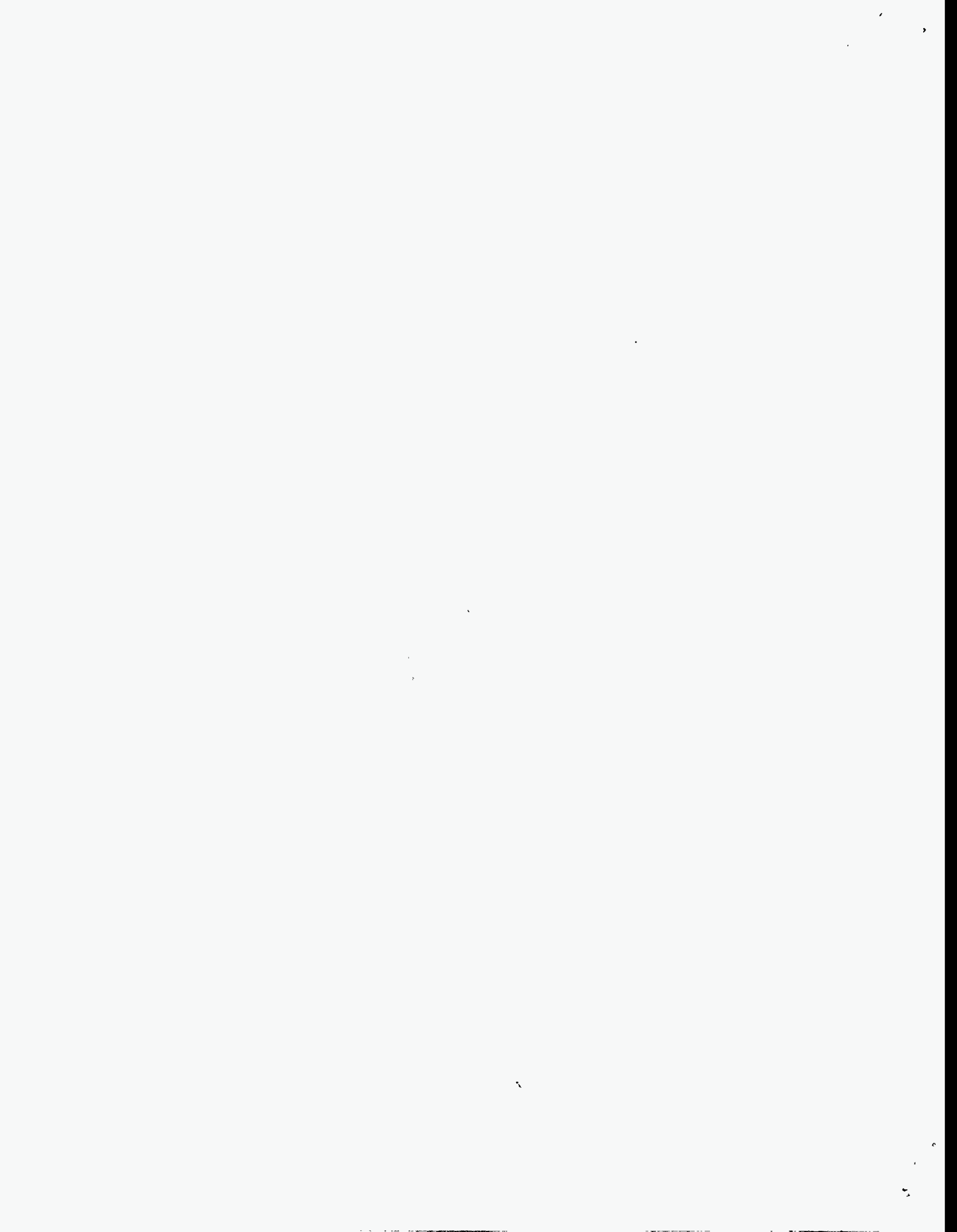

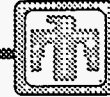

Vacuum Considerations in Sealing Flat Panel Displays

**National Center for Advanced Information Component
Manufacturing (NCAICM)**

- **DARPA funded a consortium of 4 companies and Sandia National Laboratories to develop a Flat Panel alignment and sealing technology.**
- **Work included the development in Glass Materials, Lasers, Thermo/Stress Analysis and equipment development.**
- **Goal - To develop an align and seal technology inside a vacuum system.**

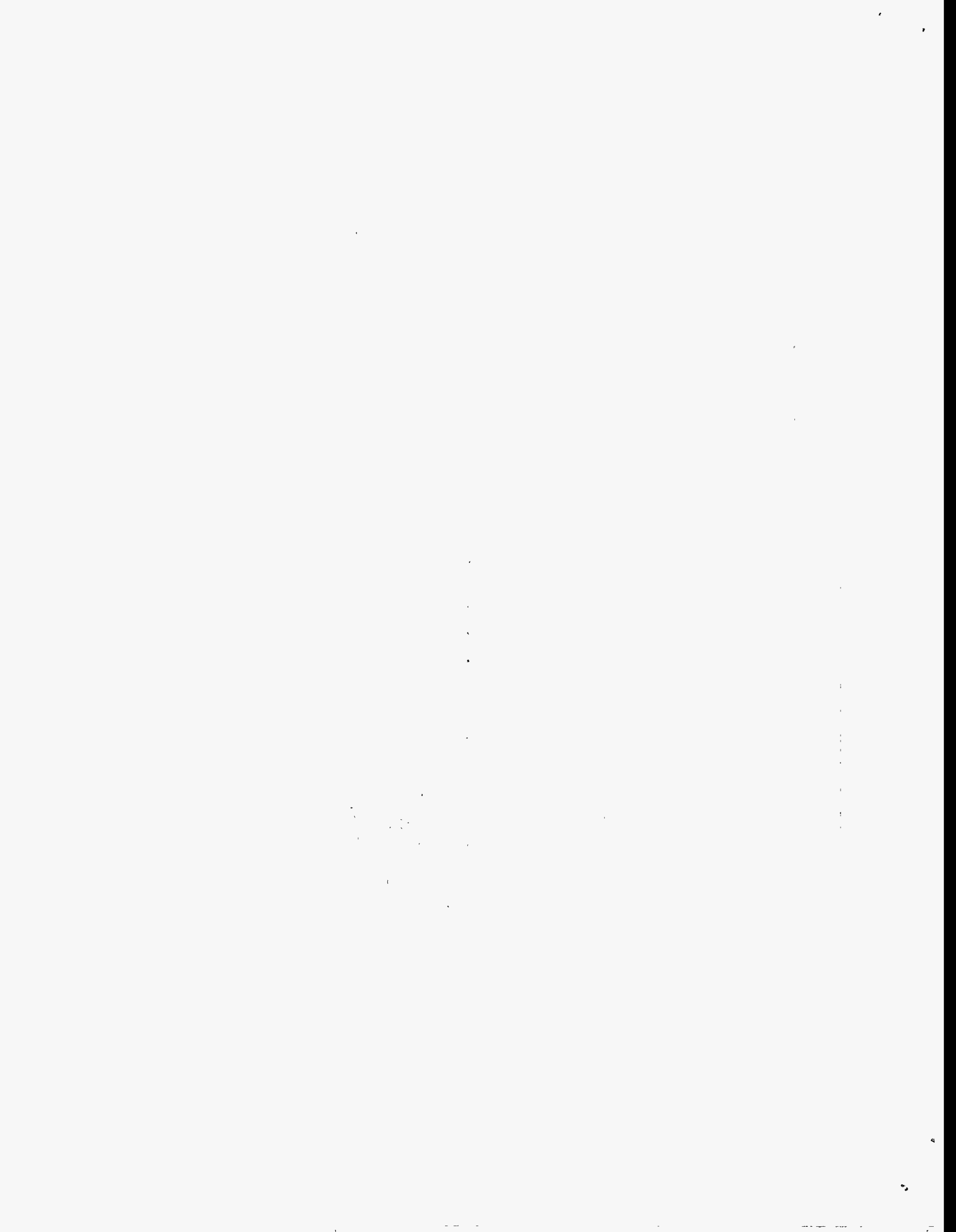

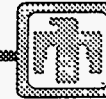

Vacuum Considerations in Sealing Flat Panel Displays

- Process Desired by the Vendors in the Consortium
 - Vacuum Bake the parts with large gap (20mm)
 - Backfill the chamber with high purity gas
 - Align Flat Panels to within 1 micron per inch of panel length
 - Melt the sealing glass and drop to an anneal cycle
 - Evacuate and tip off the FED style panels
or rebackfill and tip off
the plasma style panels

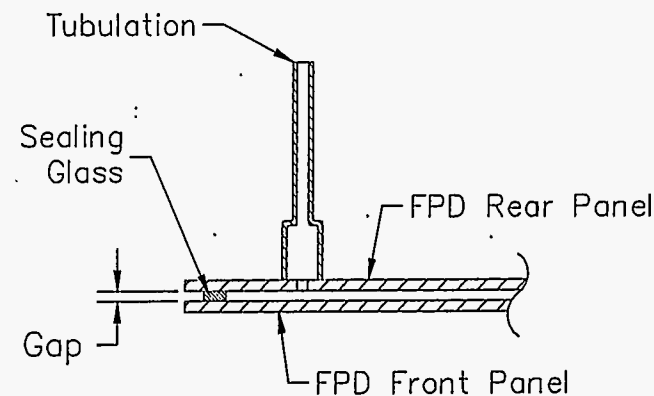

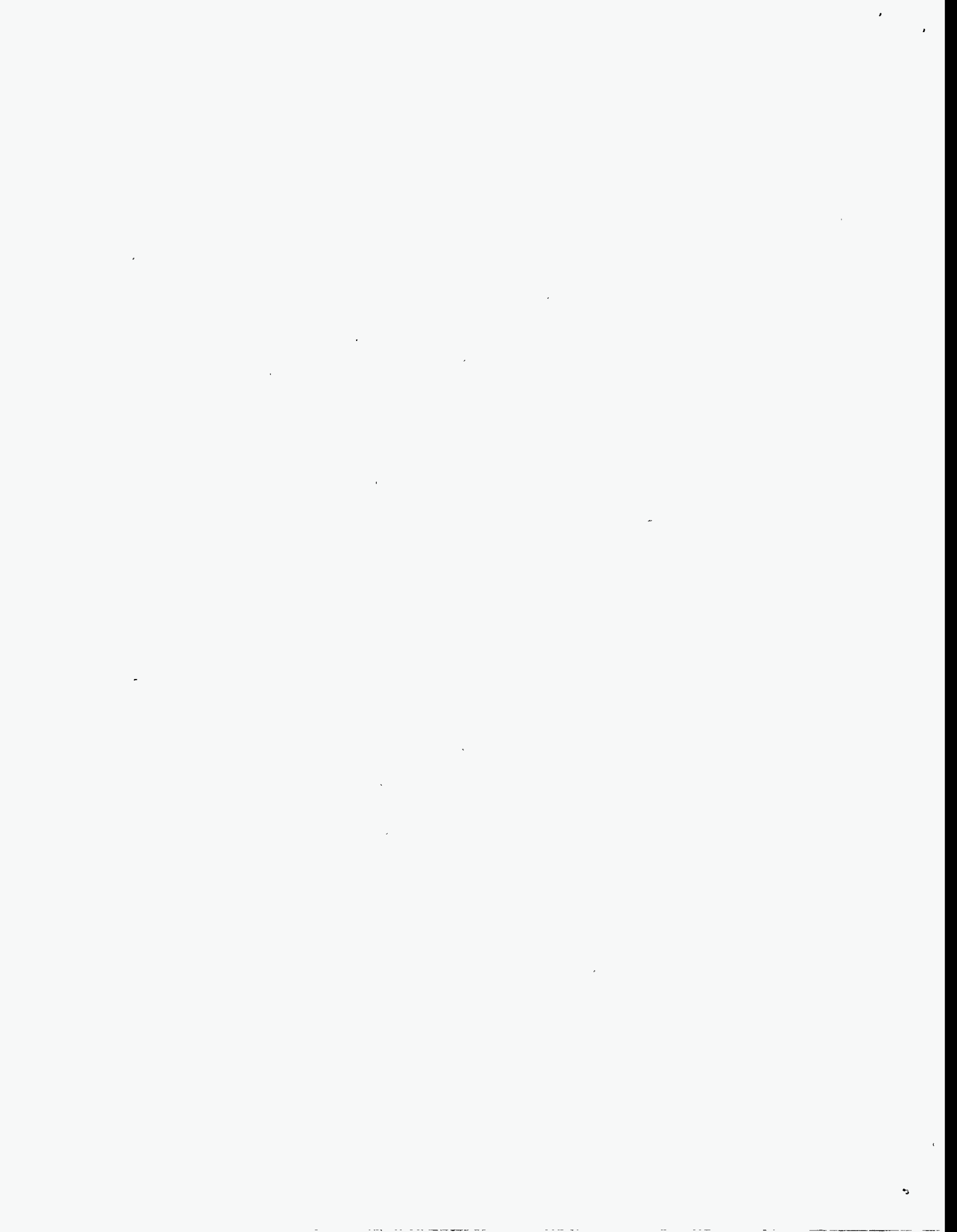

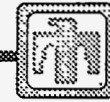

NCAICM Flat Panel Alignment and Sealing System

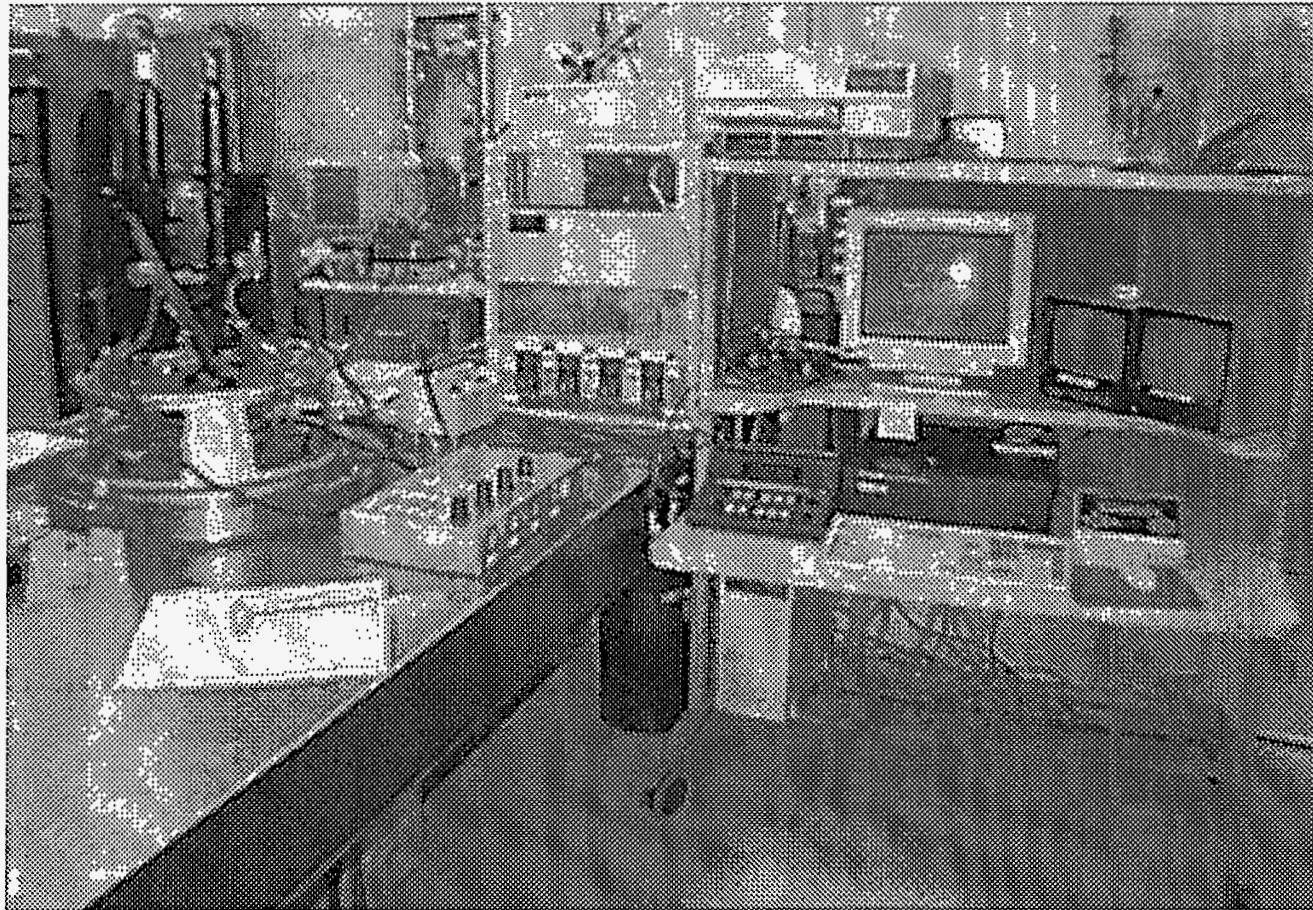

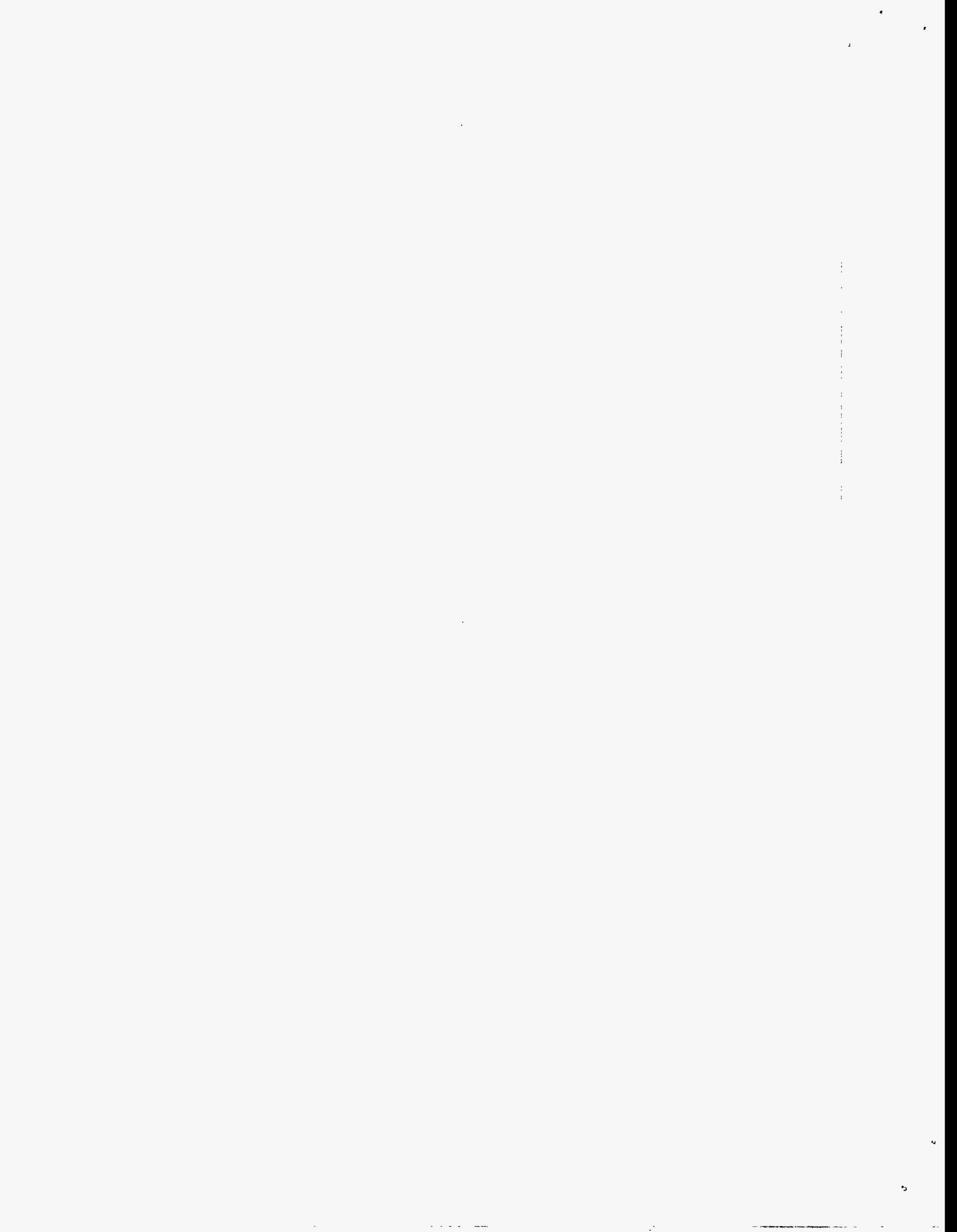

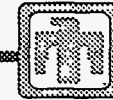

Vacuum Considerations in Sealing Flat Panel Displays

- **Development was broken into two Phases**
 - **Phase I Air Align and Sealing Device**
 - **Phase II Vacuum Align and Sealing device**
- **Phase I Design - Open Air Align and Seal**
 - **Conical Shapes used for Stiffness**
 - **Replaceable Platen's include Heater and Vacuum Chuck**
 - **Design is compatible with a later Vacuum System**
 - **Access was given for Laser Access on 4 sides**
 - **Long Standoff microscopes capture alignment marks on the flat panels**

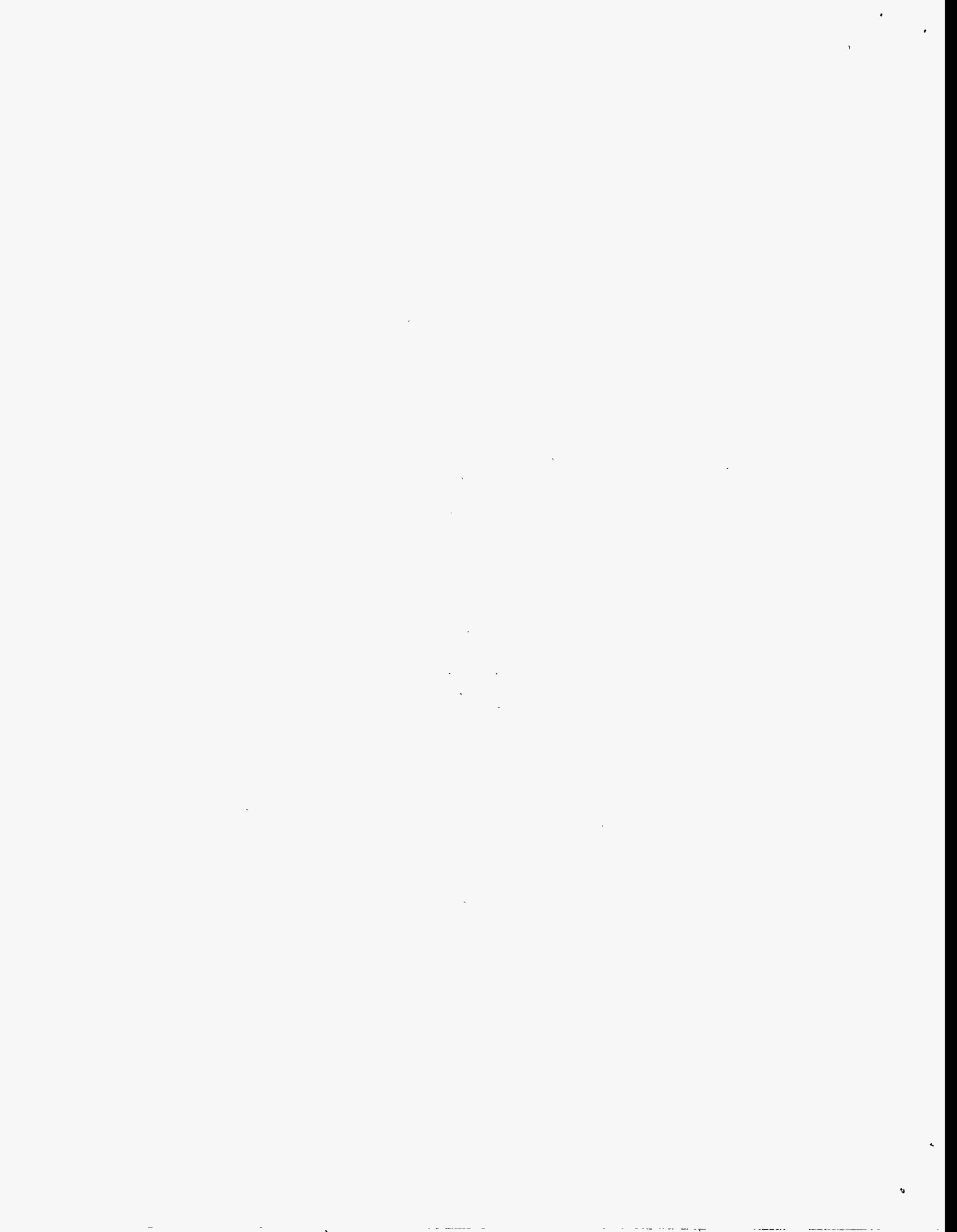

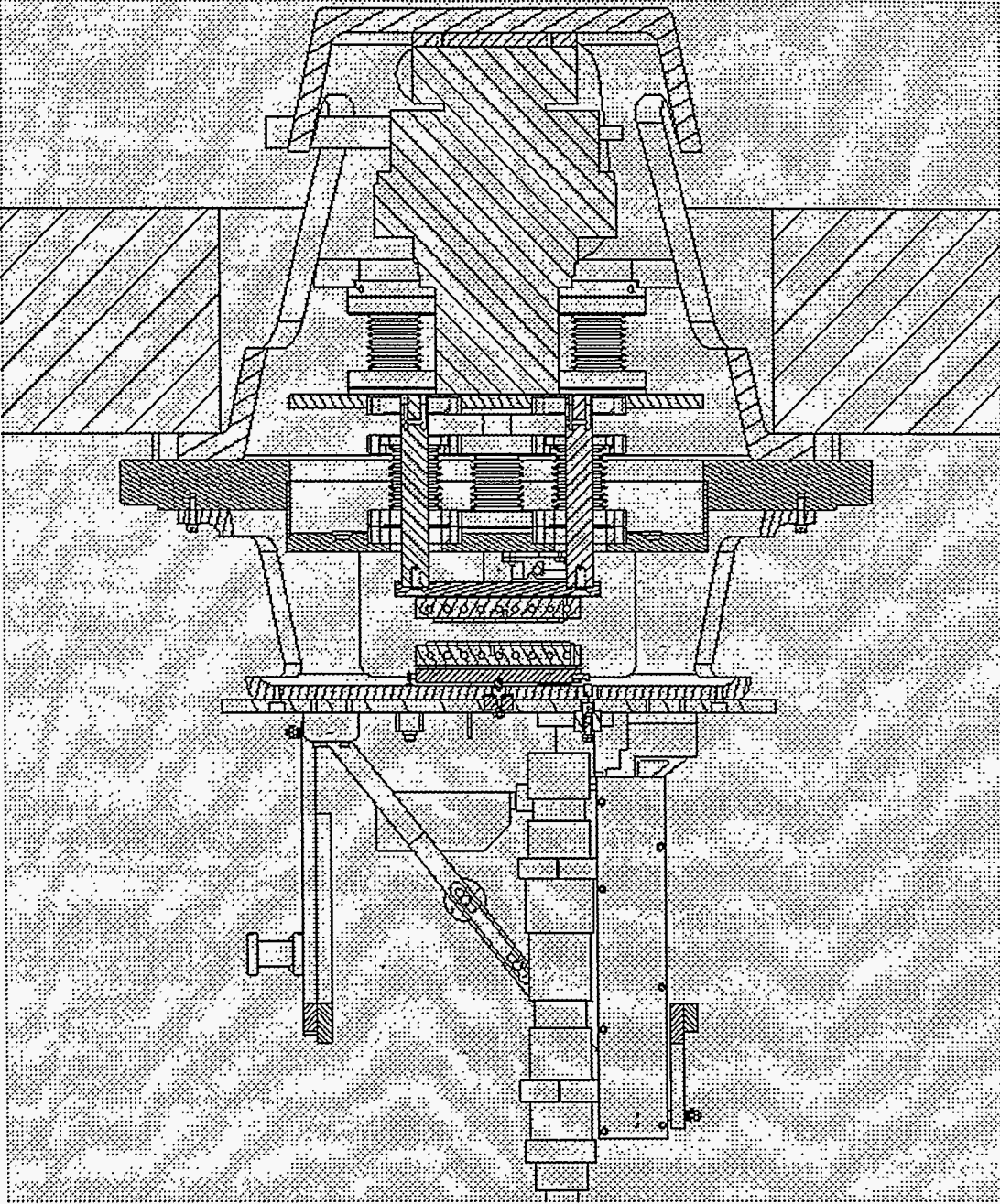

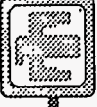

NCAICM Flat Panel Alignment and Sealing System

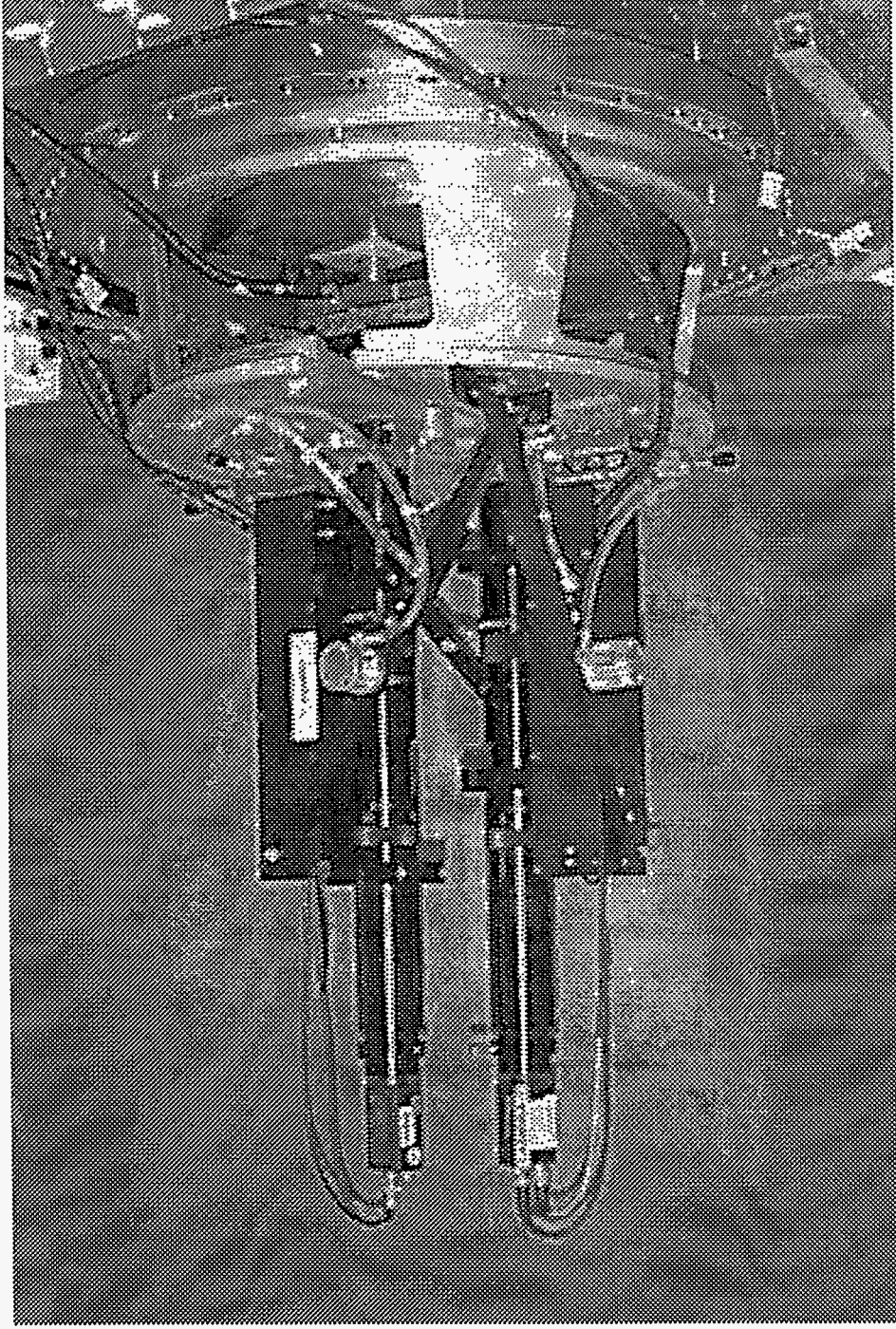

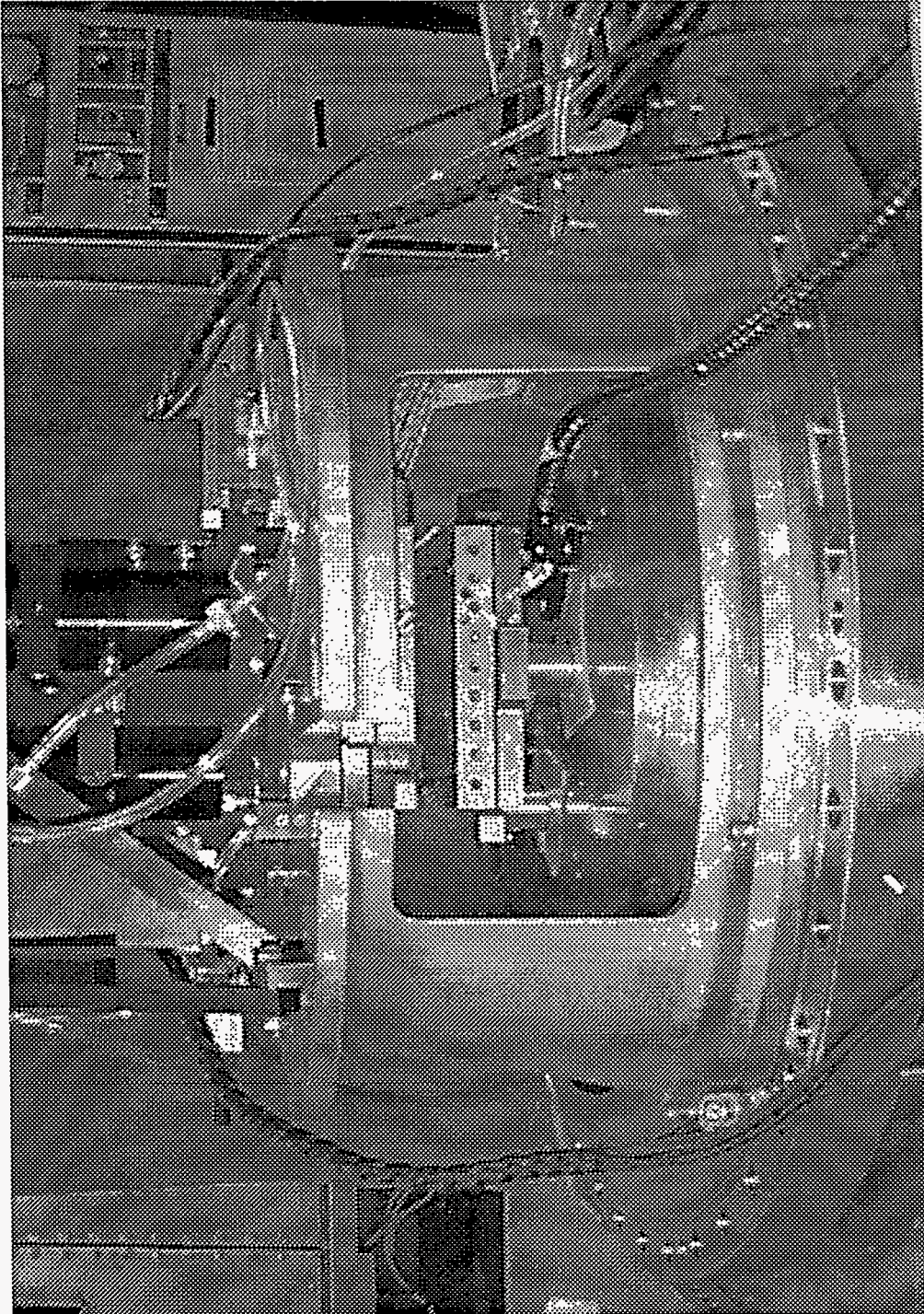

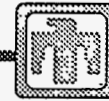

NCAICM Flat Panel Alignment and Sealing System

•Platen Design Requirements

- Kinematic mount will allow quick locating of different vendors platens**
- Thermal Isolation with the ceramic ball Kinematic Mount**
- Aluminium Platen thermal modelled for uniformity**
 - < 6 deg C from Center to Corner in Air**
- Rod Heaters available with vacuum compatibility**
- Testing to 550 Deg C showed <0.0005 warpage**
- Vacuum Chuck to hold parts in positive pressure**
- Viewport to the Flat Panel Alignment marks**

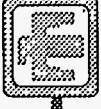

NCAICM Flat Panel Alignment and Sealing System

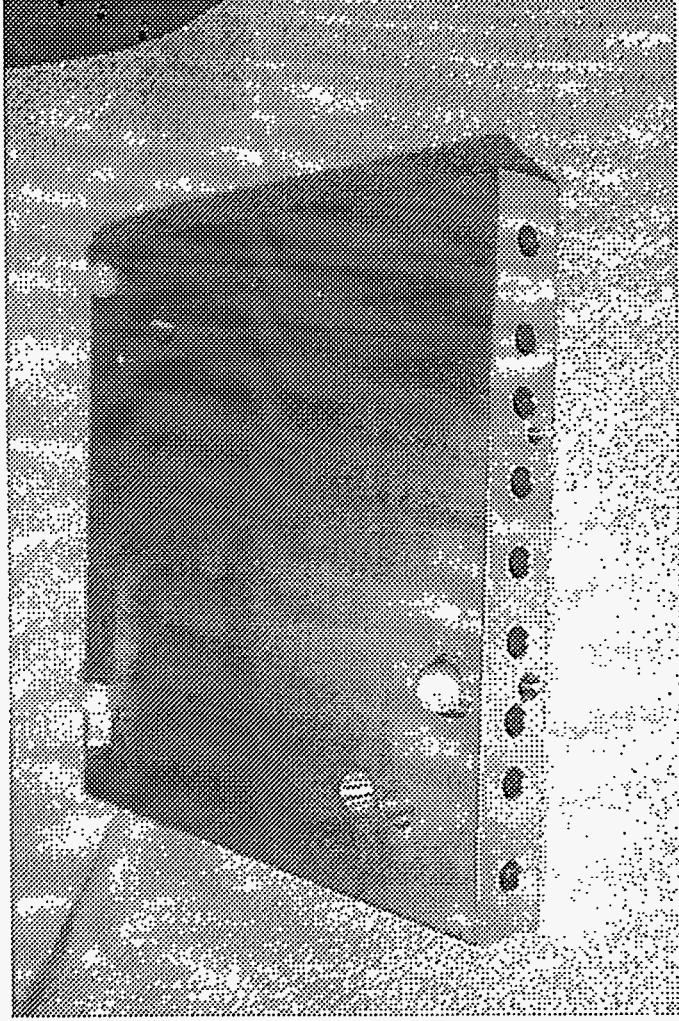

Kinematic Mounts

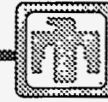

NCAICM Flat Panel Alignment and Sealing System



NCAICM Platen

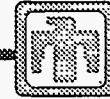

NCAICM Flat Panel Alignment and Sealing System

- **Phase 1 Design Developments**
 - **Camera Image Motion Problems**
 - **Soft-Stiff Structural Bracing**
 - **Air Jets on Support Plate to mix air**
 - **Top Rotation Plate**
 - **Aluminum Platen Scratching/Aluminum Transfer**
 - **Chrome Plating (3000 Angstroms Thick)**
 - **Reduced vacuum porting**
 - **Vacuum Compatible Heater Rods**

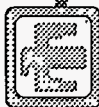

NCAICM Flat Panel Alignment and Sealing System

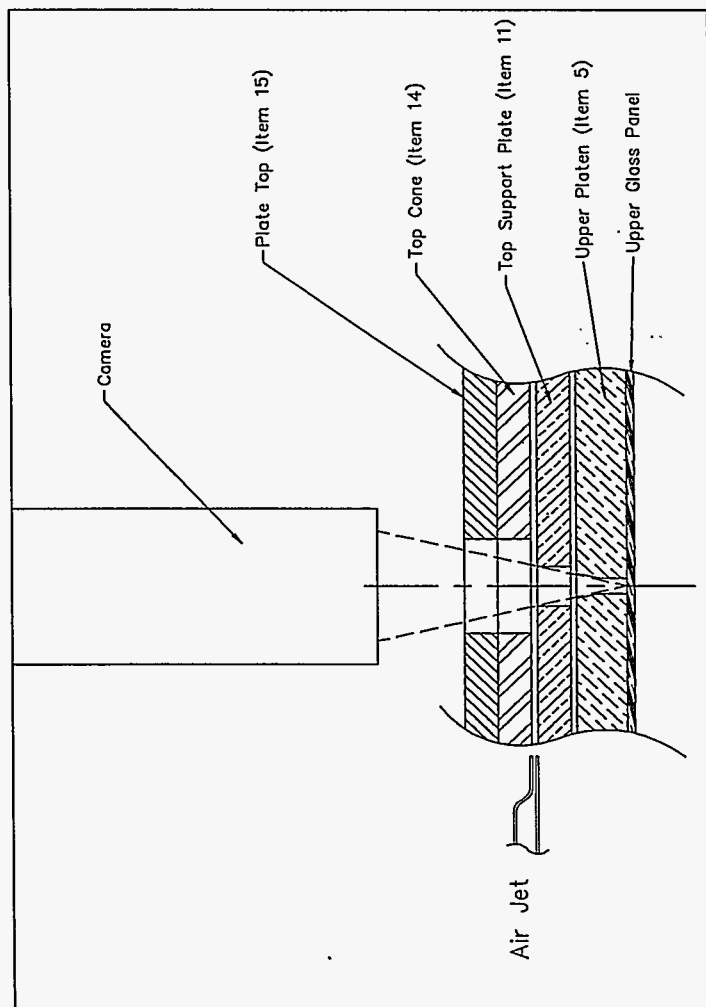

Optical System Section View

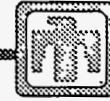

NCAICM Flat Panel Alignment and Sealing System

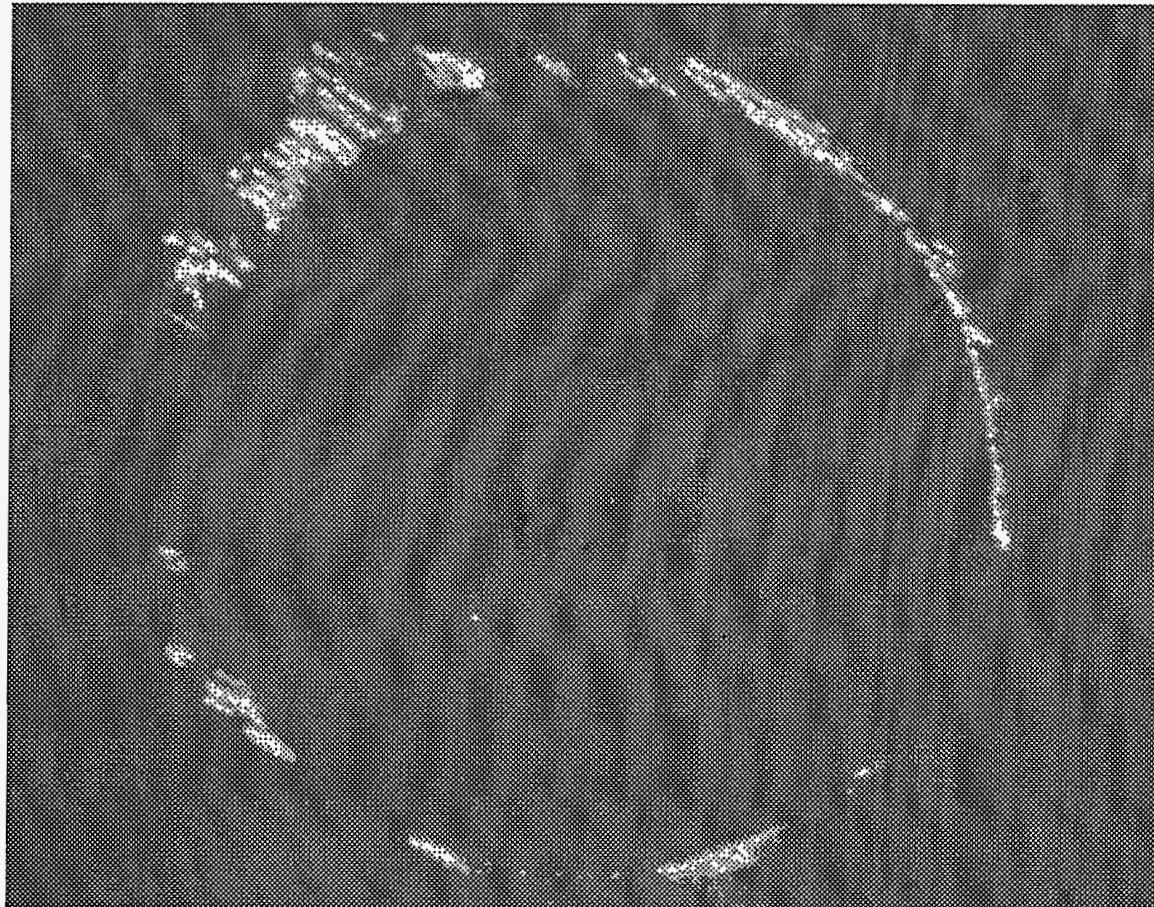

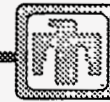

NCAICM Flat Panel Alignment and Sealing System

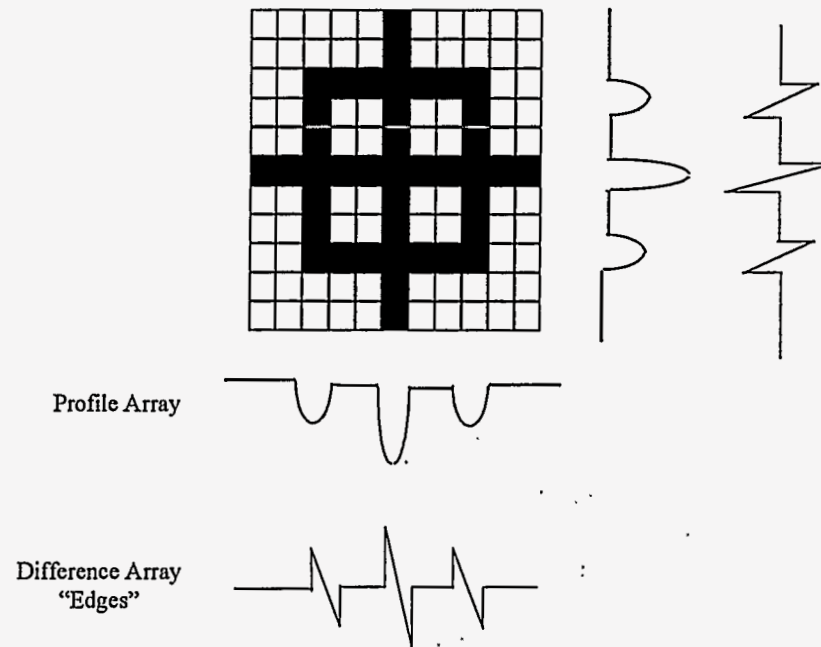

Alignment Patterns / Technique

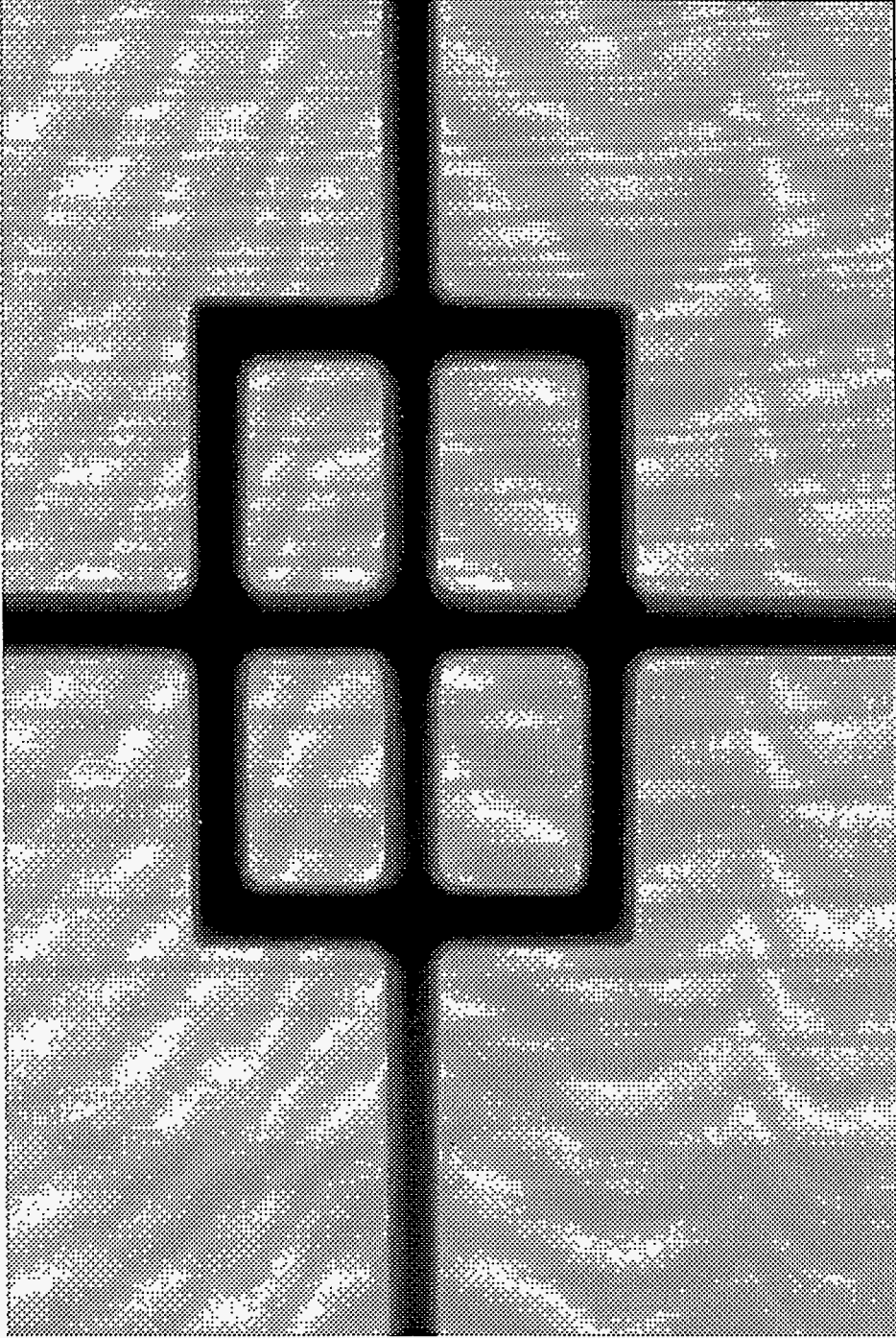
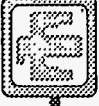

Alignment Image from 1/19/96 Sandia Test Panel

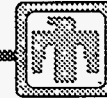

NCAICM Flat Panel Alignment and Sealing System

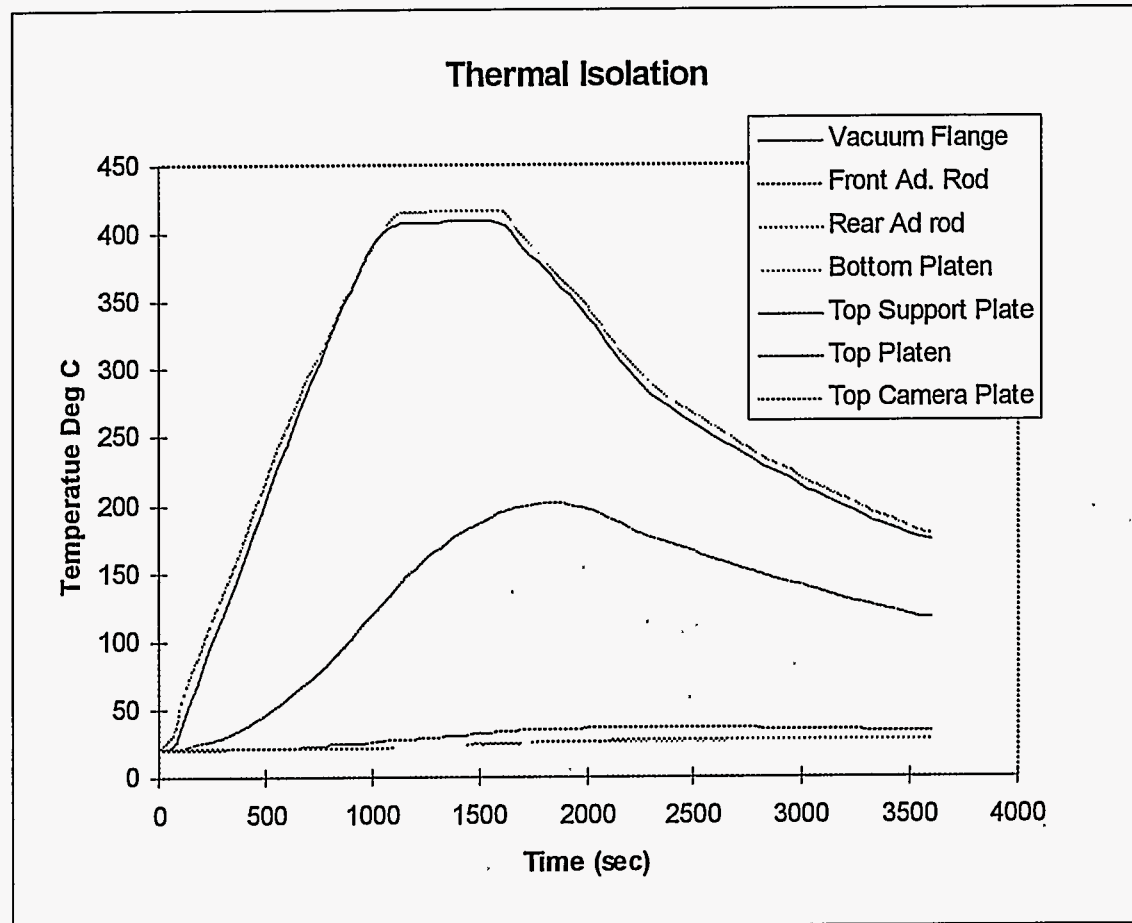



NCAICM Flat Panel Alignment and Sealing System

- **Results for Phase I Air Sealing**

- **Thermal Sealing**

- **Seals with 10^{-9} atm cc he/ sec leak rates**

- **Schott Frit - (420 Deg C melting point)**

- **SEM-COM, SCB-2 Silk Screenable Glass (520 Deg C)**

- **Panel Sizes Sealed (Approximate)**

- **8" x 10 "**

- **3.8" x 4.6"**

- **2.5" x 2.5"**

- **Panels heated at 20deg C/min. - no breakage**

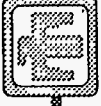

NCAICM Flat Panel Alignment and Sealing System

- Results for Phase I Air Sealing
 - Alignment
 - Process development still underway
 - Best Result to Date
 - 10/2/96 Test with SCB-2 Material*

<u>Errors (microns)</u>	<u>X dim</u>	<u>Y dim</u>
Lower Left	2.4	0.7
Upper Right	1.7	8.6

*Measured on a OGP Avant 200

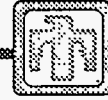

NCAICM Flat Panel Alignment and Sealing System

- **Design Areas for Improvements**
 - **Eliminate Force Sensor variations from heating/stress**
 - **Extend Theta rotation capability (>600 arc-seconds)**
 - **Flatness adjustment of the platens (< 25 microns)**
 - **Finer control of Camera Air Jet**
 - **Automation of the Pneumatic Controls**

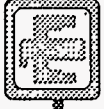

NCAICM Flat Panel Alignment and Sealing System

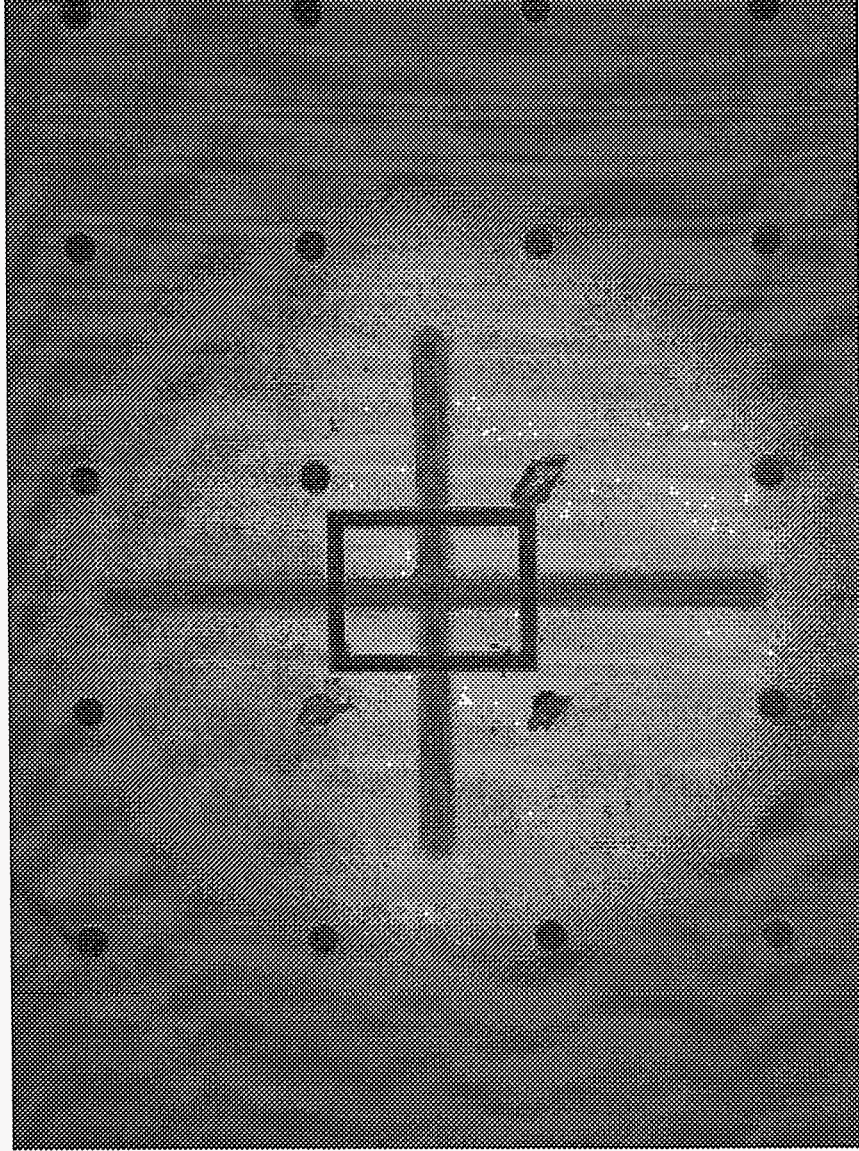

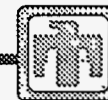

NCAICM Flat Panel Alignment and Sealing System

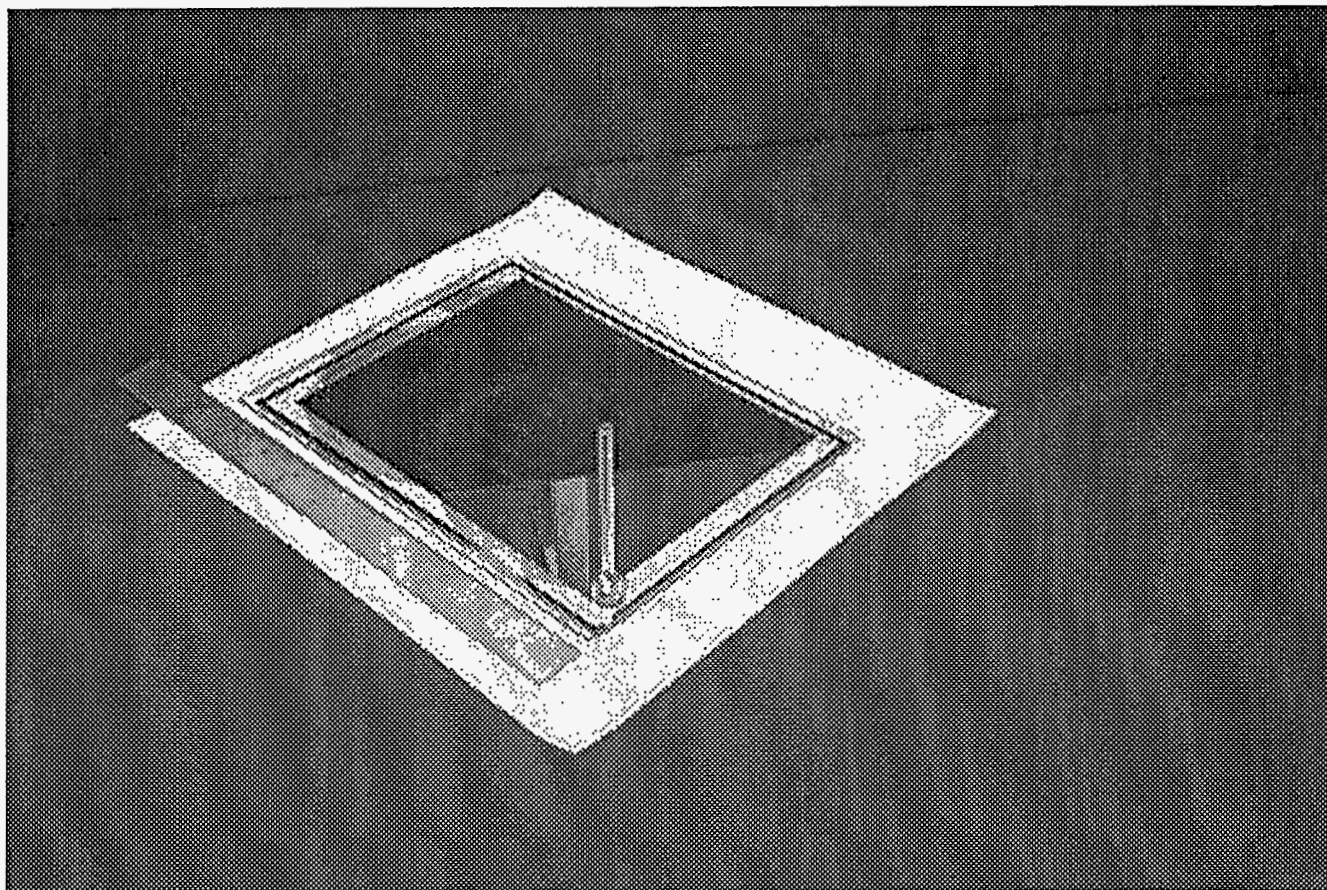

8" x 10" Sealed Vendor Panel

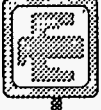

NCAICM Flat Panel Alignment and Sealing System

•Vacuum Chamber - Phase II

- Allows the Vacuum Bake out with a Large Gap between Panels
 - Present day FPD gap of 1200 to 50 microns
 - Design Bake out gap of 20,000 microns
 - Several orders of magnitude faster pump out
- Mechanically roughed, then pumped with CT-8 Cryopump
 - Operating pressure of 10^{-7} torr
- Complete Align and Seal in a clean environment
 - Backfill would be UHP gas as required for each vendor
 - Clean environment may allow elimination of the tubulation

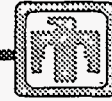

NCAICM Flat Panel Alignment and Sealing System

- **Vacuum Chamber - Phase II**

- **Present Design**

- **Based on existing system lower support structure**
 - **Bellows for translation of motion**
 - **Uses any of the Test Platens (6" square platens)**
 - **System will accommodate both laser access and thermal seals**
 - **Uses the same supports, and camera mounts and a cone design for the camera/vacuum chamber top**

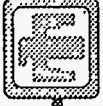

NCAICM Flat Panel Alignment and Sealing System

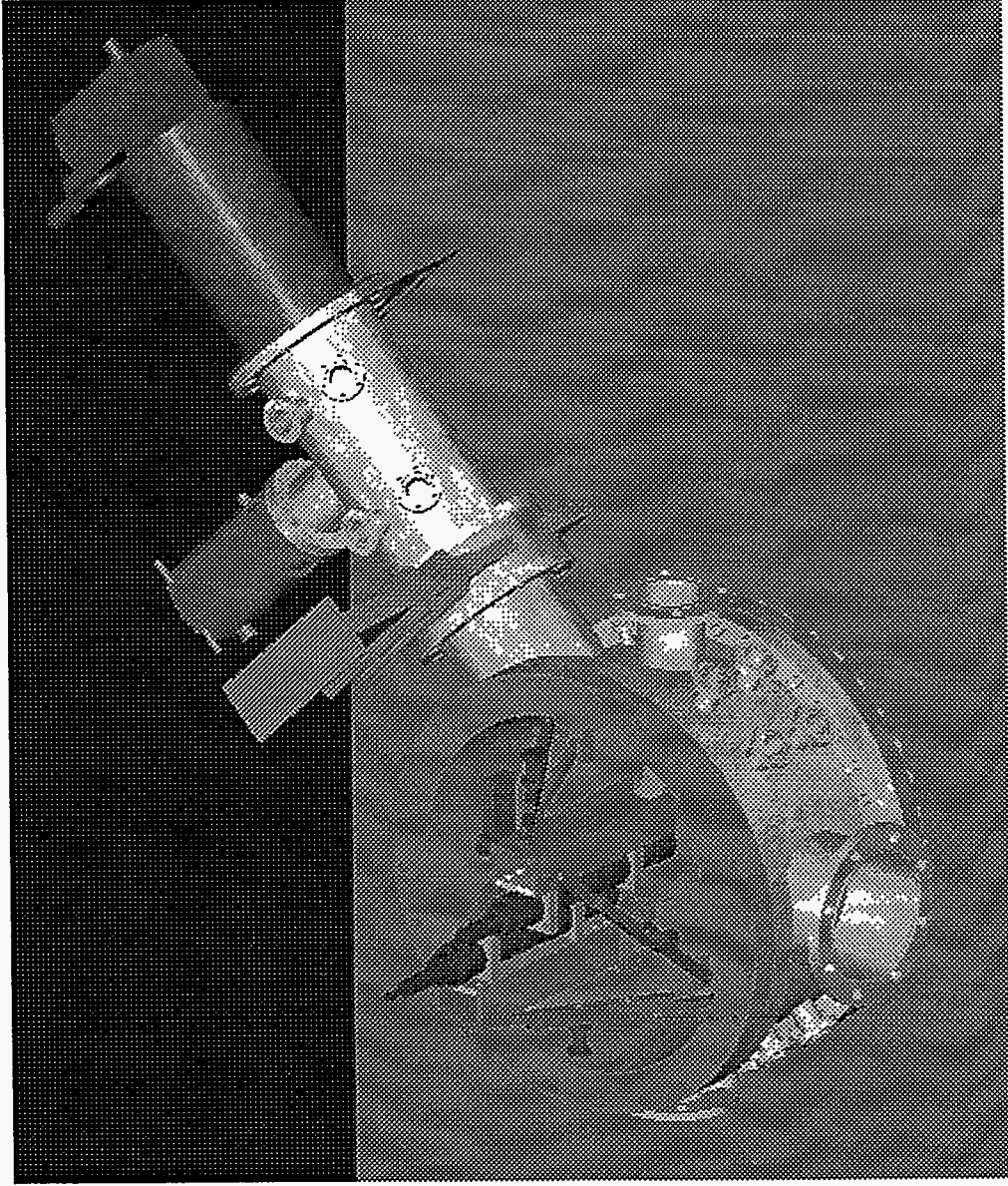

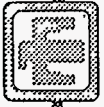

**Phase II
Sectional View**

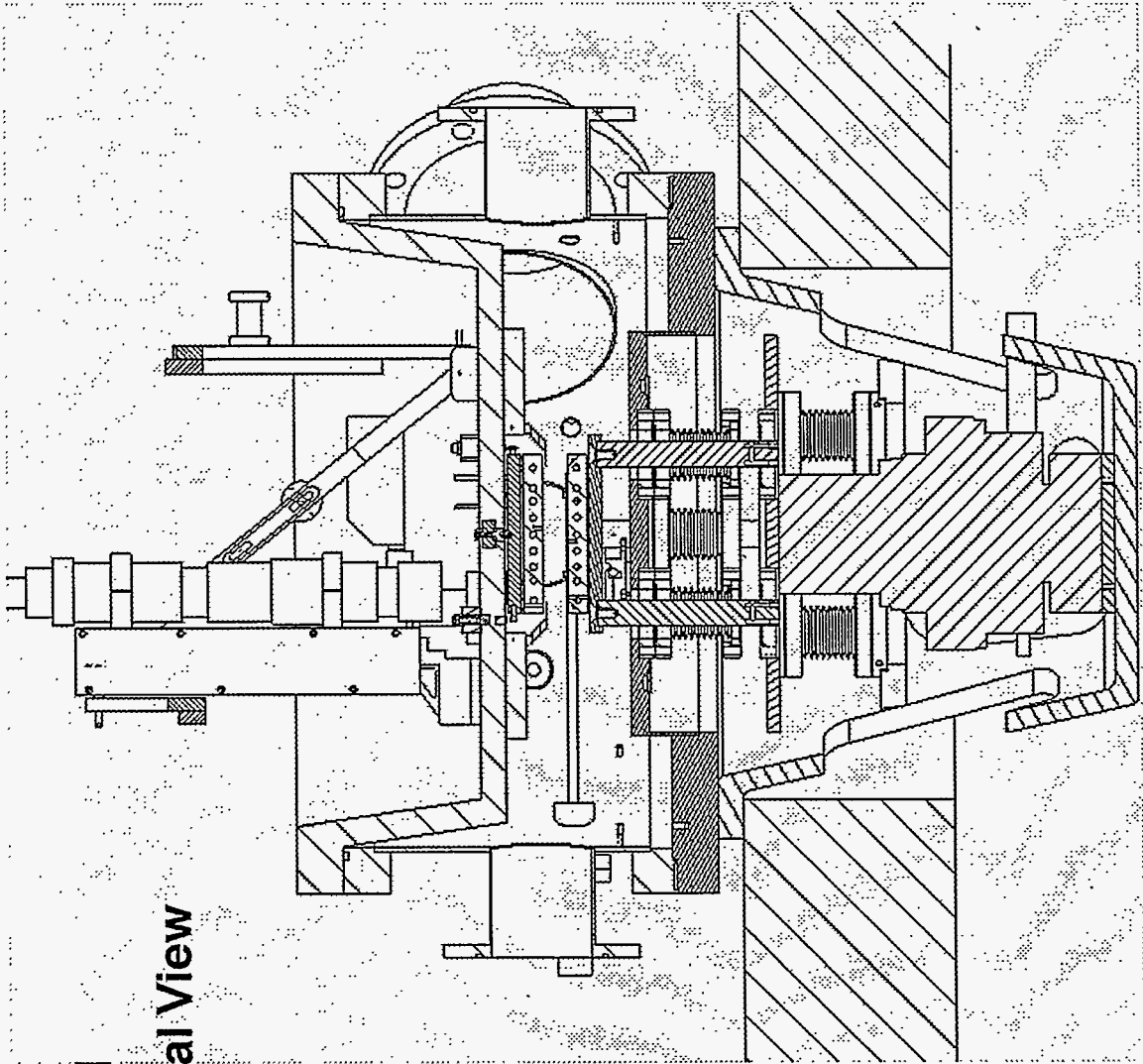

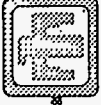

NCA/ICM Flat Panel Alignment and Sealing System

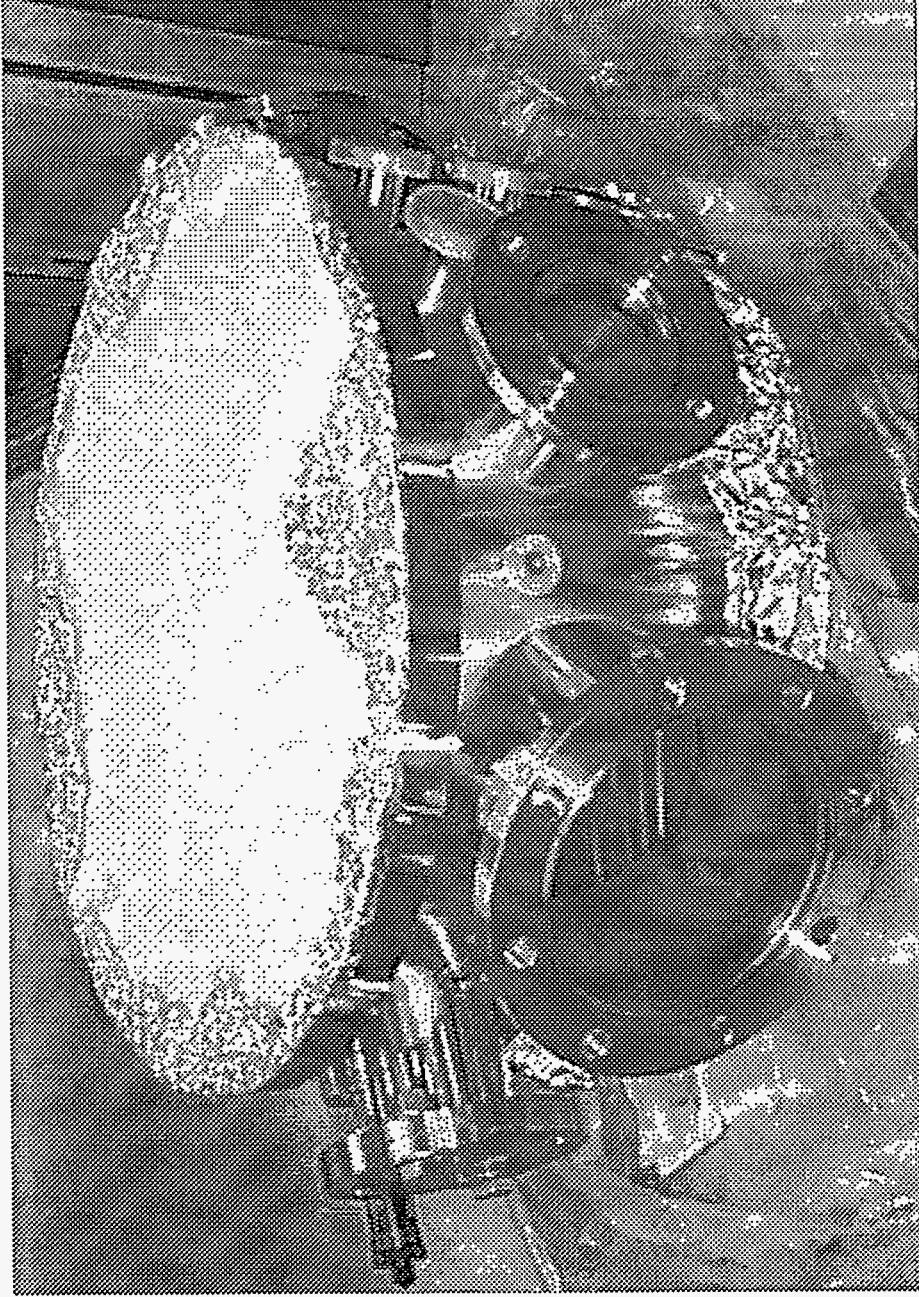

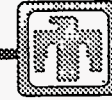

NCAICM Flat Panel Alignment and Sealing System

- **Future Developments**

- **USDC bid out to develop a high throughput device**

- **NCAICM Align and Seal Device is referenced as an available test bed for USDC development**

- **Present system with some modifications could allow higher throughput**

- **Input / Output Carousels to run temperature ramps**

- **Robotic retrieval of platens with Flat Panels could load and unload the existing alignment device**

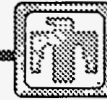

NCAICM Flat Panel Alignment and Sealing System

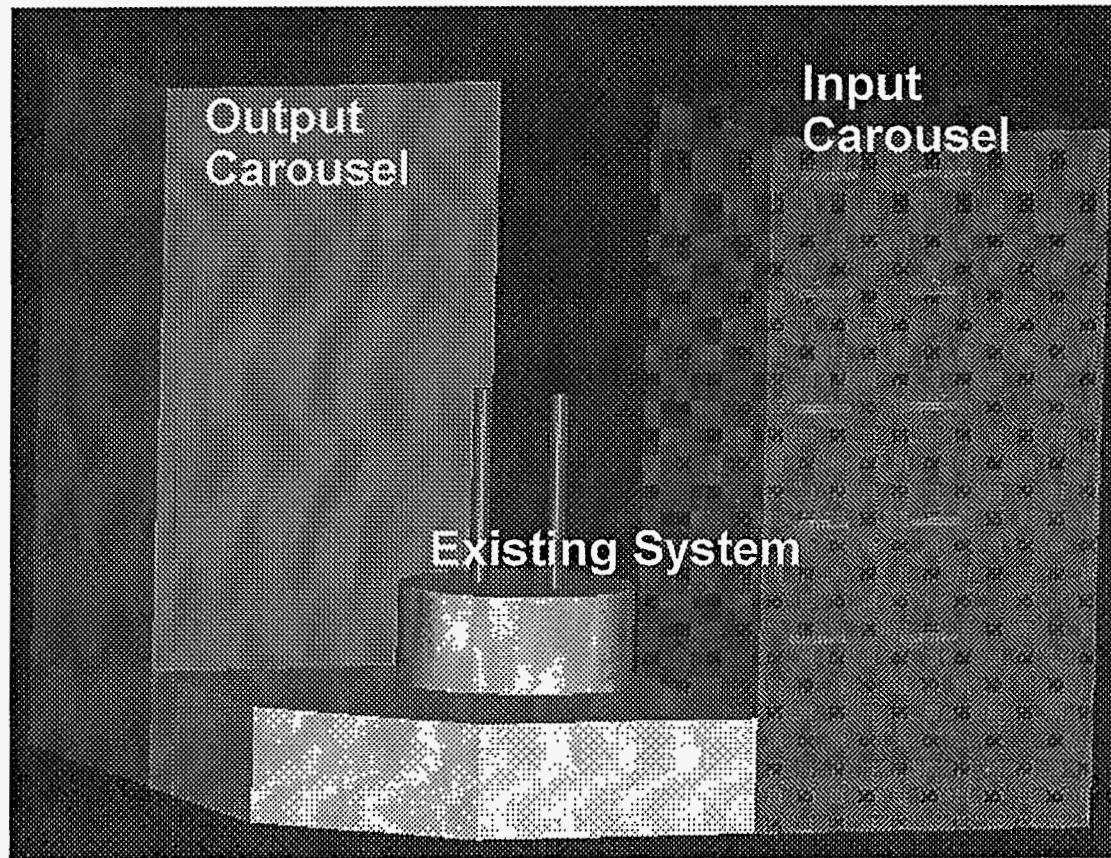

Future System



NCAICM Flat Panel Alignment and Sealing System

•Questions?