

OCT 23 1996

SANDIA REPORT

SAND96-2263 • UC-126

Unlimited Release

Printed October 1996

RECEIVED

OCT 28 1996

OSTI

Summary of Events and Geotechnical Factors Leading to Decommissioning of the Strategic Petroleum Reserve (SPR) Facility at Weeks Island, Louisiana

Stephen J. Bauer, Brian L. Ehgartner, James K. Linn, Stephen E. Lott, Thomas E. Hinkebein, Martin A. Molecke, Darrell E. Munson, James T. Neal, Allan R. Sattler, Sanford Ballard, Michael J. Bertoldi, Robert E. Gump, Kenneth E. Mills, D. William Lamb, Stewart Thompson, Robert E. Myers

Prepared by
Sandia National Laboratories
Albuquerque, New Mexico 87185 and Livermore California 94550
for the United States Department of Energy
under Contract DE-AC04-94AL85000

Approved for public release; distribution is unlimited.

SF2900Q(8-81)

MASTER

DISTRIBUTION OF THIS DOCUMENT IS UNLIMITED

8

Issued by Sandia National Laboratories, operated for the United States Department of Energy by Sandia Corporation.

NOTICE: This report was prepared as an account of work sponsored by an agency of the United States Government. Neither the United States Government nor any agency thereof, nor any of their employees, nor any of their contractors, subcontractors, or their employees, makes any warranty, express or implied, or assumes any legal liability or responsibility for the accuracy, completeness, or usefulness of any information, apparatus, product, or process disclosed, or represents that its use would not infringe privately owned rights. Reference herein to any specific commercial product, process, or service by trade name, trademark, manufacturer, or otherwise, does not necessarily constitute or imply its endorsement, recommendation, or favoring by the United States Government, any agency thereof or any of their contractors or subcontractors. The views and opinions expressed herein do not necessarily state or reflect those of the United States Government, any agency thereof or any of their contractors.

Printed in the United States of America. This report has been reproduced directly from the best available copy.

Available to DOE and DOE contractors from
Office of Scientific and Technical Information
PO Box 62
Oak Ridge, TN 37831

Prices available from (615) 576-8401, FTS 626-8401

Available to the public from
National Technical Information Service
US Department of Commerce
5285 Port Royal Rd
Springfield, VA 22161

NTIS price codes
Printed copy: A03
Microfiche copy: A01

DISCLAIMER

Portions of this document may be illegible in electronic image products. Images are produced from the best available original document.

SAND96-2263
Unlimited Release
Printed October 1996

Distribution
Category UC-126

Summary of Events and Geotechnical Factors Leading to Decommissioning of the Strategic Petroleum Reserve (SPR) Facility at Weeks Island, Louisiana

James T. Neal, Editor

Stephen J. Bauer, Brian L. Ehgartner, James K. Linn, Stephen E. Lott, Thomas E. Hinkebein,
Martin A. Molecke, Darrell E. Munson, James T. Neal, Allan R. Sattler
Underground Storage Technology Department

Sanford Ballard
Advanced Geophysical Technology Department

Sandia National Laboratories
Albuquerque, New Mexico 87185

Michael J. Bertoldi, Robert E. Gump, Kenneth E. Mills
DynMcDermott Petroleum Operations Company
New Orleans, Louisiana 70123

D. William Lamb, Stewart Thompson
Acres International, Corporation
Amherst, New York 14228

Robert E. Myers
U. S. Department of Energy
New Orleans, Louisiana 70123

ABSTRACT

A sinkhole discovered over the edge of the Strategic Petroleum Reserve storage facility at Weeks Island salt dome, Louisiana, led to decommissioning the site during 1995-1998, following extensive diagnostics in 1994. The sinkhole resulted from mine-induced fractures in the salt which took many years to develop, eventually causing fresh water to leak into the storage chamber and dissolve the overlying salt, thus causing overburden collapse into the void. Prior to initiating the oil removal, a freeze wall was constructed at depth around the sinkhole in 1995 to prevent water inflow; a freeze plug will remain in place until the mine is backfilled with brine in 1997-8, and stability is reached. Residual oil will be removed; environmental monitoring has been initiated and will continue until the facility is completely plugged and abandoned, and environmental surety is achieved.

Summary of Events and Geotechnical Factors Leading to Decommissioning the Strategic Petroleum Reserve (SPR) Facility at Weeks Island, Louisiana

TABLE OF CONTENTS

	<u>Page</u>
Summary	1
Introduction and Purpose	2
Background	2
Selection and Conversion of the Weeks Island Mine	3
Geotechnical characterization	6
Preparation for Oil Fill and Storage Operation	7
Geotechnical Risks: 1984 Evaluation; 1987 Threat Study	7
Bulkhead Upgrades: 1989-1993	8
Sinkhole Identification	9
Occurrence and Characteristics of the Sinkholes	9
Sinkhole Diagnostics	13
Causal Factors	18
Sinkhole Mitigation: Brine Injection; Freeze Wall Construction	23
Geotechnical Risk Evaluation and Modeling, 1995	26
Oil Recovery and Brine Backfill Operations	27
Closure and Abandonment of Mine Openings	28
Environmental Monitoring Plans	30
Continuing Effects and Sinkhole Progression	32
Key Decision Tree and Timelines	33
References	34

Table

	<u>Page</u>
Table 1 Volume of sand fill placed in Sinkhole #1 from March through December 1994.	12

Figures

	<u>Page</u>
1 Isometric view of Weeks Island manways	4
2 Weeks Island map, showing mine outlines, salt contours, and sinkholes	10
3 Cumulative volume of fill sand at Sinkhole 1	12
4 Subsidence volume at Sinkhole 1, cubic yards per day	12
5 Diagrammatic representation of exploratory drilling at Sinkhole 1	15
6 Isotopic evolution of brine in fill holes, 1987-1993	17
7 Top of salt contours over mined openings	19
8 Geomechanical modeling results of Ehgartner and Hoffman	20
9 Conceptual development of fracturing and formation of Sinkhole 1	21
10 Predicted dilatant damage from modeling	22
11 Brine injection and Fill Hole sump inflow	24
12 Timelines for environmental monitoring activities.	31
13 Overall timelines for Weeks Island key events and decommissioning schedule.	33

S U M M A R Y

In December 1994 the Department of Energy (DOE) announced it would decommission the Strategic Petroleum Reserve (SPR) oil storage facility at Weeks Island, Louisiana, because of geotechnical conditions (principally a sinkhole) that posed a significant risk of future oil loss and potential environmental damage. The initial geotechnical characterization of the facility did not explicitly acknowledge the threat of a surface sinkhole, even though in-mine leaks had occurred around the Service Shaft and the Markel Wet Drift. Risk assessments conducted in 1984 and later recognized mechanical limitations in the existing bulkheads to withstand full hydrostatic pressures in the event of mine flooding that could result from potential leaks. As a result of these assessments, bulkhead upgrades were constructed during 1991-1993 in the Service Shaft and two raisebores, and in the Johnston and Sandrik drifts in 1992, which now isolate the Markel Mine and the Morton shafts from the SPR manways. An alternate drawdown system was also instituted, along with an air dryer system in the manways to facilitate early detection of incipient leaks. An improved surface subsidence monitoring network was also installed in 1989. The first sinkhole was observed in May 1992 and a second in February 1995.

The limits of the original mining at Weeks Island were controlled by a combination of geological factors, including a variety of anomalous features: gas outbursts, shear zones, sand, oil seeps, black salt, and brine seeps, all of which had been mapped and investigated. Mining on the southern edge terminated along a planar zone characterized by gas outbursts, black salt, and brine seeps. The two level mine produced a stress state conducive to bending and stretching of the overlying salt and sand as a result of salt creep toward the mine openings. The bending and stretching likely caused fractures in the salt to extend from the mine to the top of salt in the vicinity of the first and second sinkholes, discovered in 1992 and 1995, respectively. Once a fracture path was established, groundwater flow of undersaturated brine through the fractures eventually produced dissolution voids on the top of salt. Sediment collapse into these voids produced the sinkholes. Inflow of undersaturated brine can be expected to gradually increase as continuing dissolution occurs, posing some risk to the environmentally safe storage of oil, and creating the requirement to withdraw the oil and decommission the facility.

Stabilization of the first, and most significant, sinkhole has been effected by injecting saturated brine into the throat below the top of salt. Construction of a freezeway around the sinkhole provides added hydrologic control during drawdown and relocation of the oil. The second, and less significant, sinkhole showed minor, episodic slumping in August 1996 but warranted no additional study or mitigation efforts at that time.

Drawdown of the oil was expected to be completed by November 1996, at which time residual oil remaining in the mine will be recovered by skimming in conjunction with brine filling. Environmental monitoring has been conducted throughout the decommissioning process and will continue for at least five years following site abandonment, currently scheduled for mid-1999.

INTRODUCTION AND PURPOSE

In December 1994 the Department of Energy (DOE) announced that it would decommission the Weeks Island oil storage facility because of apparent geotechnical problems that posed a significant risk of future oil loss and potential environmental damage. *The precipitating event was a sinkhole discovered in May 1992 over the southern edge of the underground facility, but the factors responsible for this occurrence began years before, as is now better understood.* Investigations undertaken in 1994 and 1995 into the cause of surface sinkholes have verified that water from the surface aquifer is seeping into the Strategic Petroleum Reserve's (SPR) underground oil storage chamber at the Weeks Island site. As a result, the Department is transferring the oil to other SPR storage facilities in Louisiana and Texas, and will decommission the Site by mid-1999.

This report summarizes the geotechnical and engineering information that influenced the decision to close the Weeks Island facility, including listing and summarizing documents relevant to the decision process. The implications of this facility closure extend well beyond Weeks Island—other conventional mines in salt may face similar eventualities. *However, the Weeks Island exigency is not relevant to the four remaining SPR sites (containing leached caverns), and this may not be understood by most people, regardless of technical orientation.* The availability of this information summary may be a helpful resource during the 1995-1999 decommissioning process.

BACKGROUND

The Strategic Petroleum Reserve was authorized by Congress with the enactment of Public Law 94-163, the Energy Policy and Conservation Act (EPCA) on December 22, 1975, which established United States policy to store up to one billion barrels of crude oil to reduce the impact of a severe energy supply interruption and to carry out the obligations of the United States under the International Energy Program. Additional amendments to EPCA (DOE, 1995a) have modified the authorizing legislation, but the initial intent has not changed.

Prior to the enacting legislation, a DOE predecessor, the Federal Energy Administration (FEA) had worked on the storage concept and contracted two studies earlier in 1975—one to look at storage in existing leached caverns, and the other in existing mined cavities. Existing mines had the appeal of coming "on line" faster and also multiple withdrawals could be made without enlarging the cavities such as in a leached-cavern storage system. Acres American in conjunction with Butler Associates of Tulsa undertook the latter effort; their Phase 1 report, issued in October 1975, identified 11 potential mines that might be used for storing crude oil. A Phase 1 Addendum report was issued in August of 1976 to address several political and supply distribution concerns. It also recommended that further consideration be given only to five mines, two in limestone (Ironton, Ohio, and Central Rock, Kentucky), and three in salt (Kleer, Texas, Côte Blanche, Louisiana, and Weeks Island, Louisiana (FEA, 1977).

Phase 2 of the study included FEA's assessment of the Phase 1 report and the decision to proceed with Phase 3 (preliminary design, cost estimates, and construction schedules for each site). The principle employed in mine conversion followed the Scandinavian system—the only underground oil storage facilities in the world at the time. The Swedish storage concept employed bulkheads in the shafts, through which submersible pumps were suspended from the surface with pump casings passing through the bulkheads. This system completely averts the need for permanent access underground; however, fundamental variations were required at Weeks Island to enable mining to continue during the conversion—higher-elevation access manways between the shafts were constructed, from which new drifts were driven leading to the Markel Mine, an interim mine developed by Morton Salt Company (Fig. 1).

SELECTION AND CONVERSION OF THE WEEKS ISLAND MINE

All of the candidate sites except Weeks Island had logistical or operational problems, or were limited by volume. The Weeks Island mine was an operational, two-level room and pillar mine in domal salt. Although geotechnical uncertainties existed at that time, such as the inability to access the upper mine level (for safety), Weeks Island had many desirable attributes, especially volume, location, and availability. Morton Salt, the mine operator at Weeks Island, estimated the volume originally at 89 million barrels, which was a significant advantage over the other candidates. The decision to

use the Weeks Island mine became an obvious, expedient choice and further studies of mine suitability were instituted.

The Weeks Island salt dome is located 14 miles south of New Iberia, Louisiana, and is the central dome in the Five Islands chain, along with Belle Isle and Côte Blanche to the south, and Avery and Jefferson Islands to the north. All five have been mined because of their near-surface salt, and their logistical advantage near the Gulf of Mexico and the Intracoastal Waterway. Belle Isle and Jefferson Island are now closed to mining because of deliberate and inadvertent flooding, respectively. The Weeks Island mine was originally opened in 1902 and salt was extracted commercially from the upper level until 1952 and from the lower level between 1952 and 1977, at which time Morton Salt began developing its interim, or Markel mine, and new mines adjacent and to the northwest while the older workings were converted for SPR oil storage. The FEA acquired the former two-level underground salt mine, consisting of 382.92 acres, and 6.63 acres of surface land, by condemnation from Morton Salt Company in September, 1977 (DOE, 1995a). Between that time and 1982, the mine was modified in preparation to receive and store crude oil, and Morton's new mine was started. This involved continued use of the existing shafts, while advancing drifts to the interim Markel mine, and sinking of two new shafts for the new mine. During an 18 month transition interval through 1981, salt was extracted by Morton from the interim Markel mine.

Because Morton intended to maintain an operating mine at the site, the plans for conversion of the existing mine went

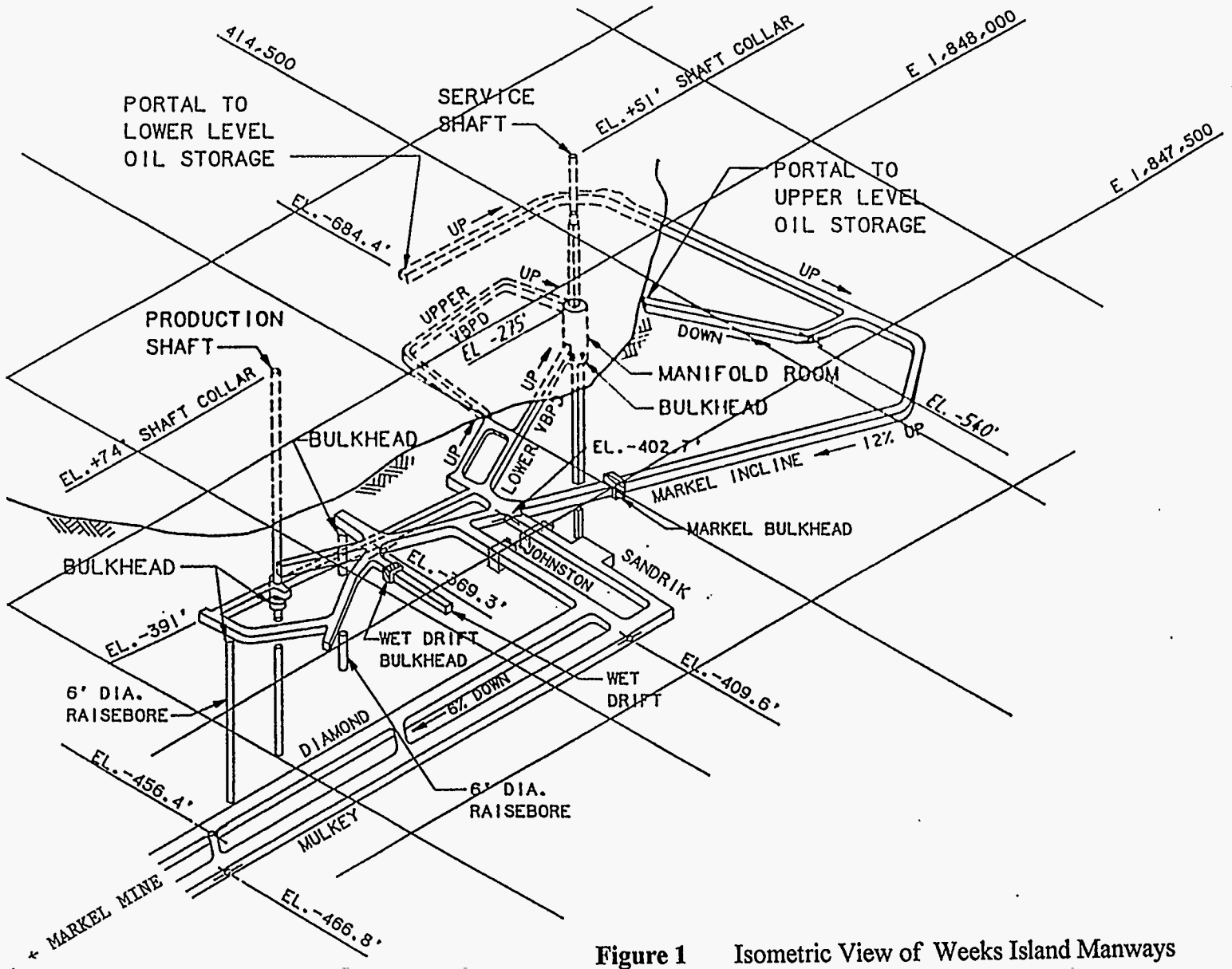

Figure 1 Isometric View of Weeks Island Manways

forward, in conjunction with plans to develop an interim mine. Thus, the commercial mining of salt continued simultaneously with development of a new mine. Several innovative solutions were introduced that allowed the continuation of commercial mining. This included continued use of the Production Shaft for hoisting salt, and creation of a manifold room in the 9-foot diameter Service Shaft. This shaft was not large enough to handle all the withdrawal pump casings. The resulting manifold room was 40 feet in diameter over a height of 80 feet, so that individual pump casings could be withdrawn in 40 foot sections and stacked in the manifold room.

While the mine conversion was in progress and the high-level drifts (above the mine) were excavated to connect the Service and Production Shafts, access drifts to the Markel Mine were started. During this process, a zone of wet salt was encountered. Minor water inflows occurred and this excavation was stopped in late 1977. In mid-December 1977 the leakage in the Wet Drift had increased to 50 gallons per hour (gph); in-mine and surface grouting undertaken in January 1978 substantially reduced the influx. Water analyses and dye injection from the surface showed the leaks were meteoric and test borings by Morton indicated that a substantial zone of wet salt existed around the Wet Drift. Martinez (1978, 1979) and other geologists believed that the drift was excavated too close to the top of the salt surface, in combination with possible blast damage, rather than being an inherent geological defect that would preclude the safe storage of crude oil. Geomechanical analysis tools were not yet developed to enable pre-

diction of the damaged zones in salt in that region due to mine subsidence. Minor leaks of connate (formation) water had been noted in the two levels at various times during the 75 years of active mining, but in-mine grouting had controlled inflow (Acres, 1987). Thus, these leaks were not believed to be of sufficient magnitude to disqualify this site for storage.

The decision was then made to isolate the Markel Wet Drift and a 35-foot thick bulkhead was constructed. However, in late 1978 the leak rate in the isolated "wet drift" had increased to nearly 200 gph and extensive grouting was undertaken through April 1979. Routine inspection and maintenance grouting has been performed periodically since then with resultant leak rates of small fractions of a gallon per hour. In April 1996 the rate was slightly more than 200 ml (0.05 gal)/hr, with only minor variation from week to week, but increasing at a slow rate.

New accessways for development of the Markel Mine were excavated without encountering any major seepage. These access drifts are called the Johnston and Sandrik drifts. As Morton continued development of the interim Markel mine, conversion of the old mine workings for SPR use began, consisting of:

- Scaling and stabilizing rooms and pillars and construction of an oil sump.
- Developing an internal drain system, including drilling drain holes between mine levels.
- Constructing a manifold room in the Service Shaft and installing piping and pumps.
- Drilling and constructing two oil fill holes.

- Constructing bulkheads in the two shafts, the Markel Incline, the two raisebores, and a vent hole.
- Development of high level manway drifts, oil distribution and control systems, and surface facilities.

The Markel mine was operated for 18 months while the two new Morton Mine shafts were sunk. Development of the new Morton Mine began with removal of salt from the -1200 foot level. The new mine has operated continuously since then, advancing to the -1000 foot level in the late 1980s. Plans for mining at the -800 ft level were still being considered in early 1996, along with preparatory steps for deeper mine levels—starting initially at -1400 feet.

GEOTECHNICAL CHARACTERIZATION

In 1977 Gulf Interstate Engineering Company contracted Acres American Incorporated to investigate and describe geotechnical conditions at the Weeks Island salt mine and confirm its suitability for crude oil storage over a period lasting for 40-50 years. This involved determining operational limitations, estimating work required for the conversion, determining safe “web” separation from any new mining activity, and establishing necessary monitoring activity for the oil storage and any new mining. The 1977 work included geological mapping, core drilling, in situ and laboratory testing of mine samples, and analyses. The following certifying conclusions regarding the two levels were presented (Acres, 1977):

- Both levels of the salt mine, including existing shafts, were certified as stable

(mechanically and hydrologically) and capable of oil containment.

- The salt mass was impermeable, for all intents and purposes.
- A characteristic salt feature during earlier mining was the periodic occurrence of gas blowouts. Although blowouts were not fully understood in 1977, they were judged to have no adverse effects on mine stability or oil containment (provided proper buffers were instituted).
- Weeks Island salt is inert to crude oil and has no adverse reactivity.
- A minimum web thickness of 300 ft should be employed between adjacent mining operations (this was subsequently increased to 650 feet in vertical section by MSHA).

Additional site characterization was undertaken by Acres (1979) to update the previous study and to further verify long-term containment potential. Specific attention was given to salt properties and potential effects in the vicinity of bulkheads and the Service Shaft. Potential for damage to equipment in the manifold room as a result of flooding was recognized.

A 1980 study conducted by Sandia National Laboratories (Ortiz, 1980) concluded that previous characterization efforts were adequate, but that problem areas existed regarding the Markel Wet Drift, and the Service Shaft. Suggestions were made to provide specific, continuing attention to these areas of water leakage, and monitoring efforts were recommended.

PREPARATION FOR OIL FILL AND STORAGE OPERATIONS

Mine conversion and preparations for oil storage were conducted in 1978 and 1979 and consisted of removing or securing loose material that could become entrained in the oil delivery system, scaling unstable mine walls, and grading the floor toward the pump sump for drainage purposes.

In late 1978 DOE awarded a contract to Ralph M. Parsons of Pasadena, CA, to carry out a safety and hazards analysis of the site. A Government Accounting Office report to Congress had been critical of certain aspects of the certification (Comptroller General, 1978), but Gulf Interstate (1978) found no reason for revising their certification. DOE requested that additional mechanical testing of salt from a higher level in the dome be carried out; Parsons subcontracted to Acres to conduct the work. The salt was obtained from the Upper Ventilation Bypass Drift near the top of the manifold room, but limited time was available to complete all of the work because of pressing schedule requirements.

One final test prior to oil movement into the mine involved hydro-testing the oil line between St. James and Weeks Island. It was reported that Atchafalaya basin water was used and approximately 400,000 barrels remained in the line when the oil movement to the site was started. This fresh water was introduced through the fill holes, causing some dissolution of salt around the sump, but the amount of salt affected is imprecise.

Oil fill proceeded on October 1, 1980, and was completed in April of 1982. No unusual occurrences or incidents were

reported during the first five years of operation that would have called into question the decision to store oil at this location.

GEOTECHNICAL RISKS: 1984-85 EVALUATIONS; 1987 THREAT STUDY

In 1984-85, Sandia National Laboratories in conjunction with Acres American, evaluated the risks for continued safe oil storage and oil withdrawal at the Weeks Island SPR facility (Beasley et al., 1985). Objectives of this evaluation were to identify potential geotechnical risk scenarios including water leaks into the Markel Wet Drift and other areas in the facility, and to recommend remedial methods for eliminating or minimizing the impacts of their occurrence. It was determined that detailed inspections, monitoring, and analyses to provide an early warning of changes in the mine were essential, based on the strong potential for in-mine leaks to develop over the life of the SPR facility. An emergency grouting program and repair capability were also considered essential and were implemented, as were provisions to protect the oil withdrawal capability from geotechnical risks. The likelihood of direct water entry into the mine was not considered sufficiently high in comparison to other perceived water-leak scenarios to warrant identification. However, the inspection and monitoring programs initiated as a result of this evaluation were instrumental in subsequent remedial actions and later sinkhole detection efforts, which led to the present drawdown and facility decommissioning.

In 1987, an accumulation of brine in the fill hole sump was noted and concern

arose because the source of the brine was unknown. The question of an external leak into the mine was examined; brine samples were analyzed geochemically (Knauth, 1987), with the guarded conclusion that the isotopic trend of the mine waters showed it possibly becoming increasingly meteoric. However, the evidence was inconclusive at the time. Several consultants were retained to address the various issues, including Thoms (1988), who reached the conclusion that a significant, measurable leak did not exist because of the lack of definitive evidence. However, the reality of concern for a possible leak was clear, and the need for continuing surveillance of brine influx was apparent. The brine inflow at the fill hole sump for the period between 1987 and the present was monitored by strapping techniques (Bauer et al., 1994). The inflow rate had decreased to about 40 gph by 1989, and then further decreased another 10-20 gph through 1992 (the first sinkhole was initially seen in May of 1992). In mid-1993, when fill hole inflow data was again collected, the rate increased to more than 50 gph by early 1994. During this period to present, the inflow has been monitored continuously. The rate increased linearly to approximately 75 gph by mid-1994, to about 160 gph by mid-1995, to slightly more than 300 gph in April 1996.

Additional analytical work was also proposed, and the need for upgrades to the oil storage system were proposed (Jacobs Engineering, 1988), and subsequently implemented.

BULKHEAD UPGRADES: 1989-1993

The accumulation of brine described earlier made the risk scenario of oil storage leakage and concomitant chamber pressurization to be a possible eventuality. As a result, inspections were made in 1988 of the concrete bulkheads that seal the shafts. This showed that cracks were visible on the upper surfaces and potentially compromised the design structural integrity over the long term. Structural analyses by Blanford et al. (1990) and others used conservatively assumed loading under flooding scenarios and concluded that the strength might be inadequate for the raisebore bulkheads that were not "keyed" in from above, and for the Service Shaft bulkhead, which contained a large number of penetrations. Consequently the Service Shaft and two raisebore bulkheads were upgraded by adding about 50 ft of additional high strength epoxy-cement grout below the existing bulkheads (Fig. 1).

The Johnston and Sandrik access drifts (Fig. 1) were considered vulnerable to flooding from the Markel mine, or of more concern, would be a pathway and reservoir area for flooding from the SPR mine. The approximate 8 MMB volume of the Markel Mine was of major concern because of the volume of salt that could potentially be leached in the area around the DOE shafts during flooding. New bulkheads were constructed across these drifts in 1992-93 to provide a barrier to water migration. Doors were included in the design to allow continued access to the Markel Mine for inspection or maintenance. These doors are kept closed under normal operations.

Another recommendation from the 1984-85 risk assessment was to further define the geologic environment at Weeks Island, especially in the vicinity of the shafts and the Markel Wet Drift (Acres, 1986, 1987). The 1987 mapping and reporting is the definitive geologic characterization available in 1996, although minor, informal revisions have been made to it.

The likelihood is high of seeing surface indications of *major* meteoric water incursion and associated salt dissolution of subsurface salt, but lesser amounts could go undetected for extended time. For added safety a water intrusion detection system was developed and installed in 1993 (Todd and Uhl, 1993). The sensors were positioned in the drifts leading into the Markel Mine and monitored on the DOE side of the isolation bulkheads. In the event that the Markel Mine were to flood, this system would provide early warning information, as direct access for regular inspections is no longer allowed for reasons of safety.

SINKHOLE IDENTIFICATION

A surface sinkhole having approximate dimensions of 36 feet across and 30 feet deep was first observed in May 1992. It was estimated to be at least a year old, based on initial surface appearance and the subsequent reverse extrapolation of growth rates. The sinkhole location was physically removed from critical surface and underground manways and caused little alarm initially, even though its appearance was striking, being adjacent to the major access road to and from the island.

In early 1995, nearly three years after the initial sinkhole discovery, a second and much smaller sinkhole was identified—on an adjacent side of the mine, but in a similar geologic setting. Both sinkhole locations were determined to be directly over the periphery of the SPR oil storage chamber, the boundary of the former room-and-pillar salt mine. The second sinkhole caused additional apprehension as the association of leaks and sinkholes over mines is now well established and this occurrence suggested that groundwater influx was again causing salt dissolution at shallow depth, and associated collapse of soil at the surface. Consequently, much attention has been and continues to be given to characterizing these sinkholes, and to their mitigation (Bauer et al., 1994).

OCCURRENCE AND CHARACTERISTICS OF THE SINKHOLES

The sediment cover at Weeks Island consists of deltaic alluvium of the ancestral Mississippi River and is about 185 feet thick over the top of salt, which is about 100 feet below sea level at Sinkhole #1. The water table conforms generally with sea level over the dome but fluctuates somewhat with topography and frequent torrential rains. Perched groundwater likely exists in the vicinity of the several ponds and lakes on the island.

The first sinkhole at Weeks Island occurred over the southern perimeter of the upper level of the SPR mine (Fig. 2). The relatively small size of the first sinkhole and lack of diagnostic evidence directly linking it to the SPR mine caused little concern at first.

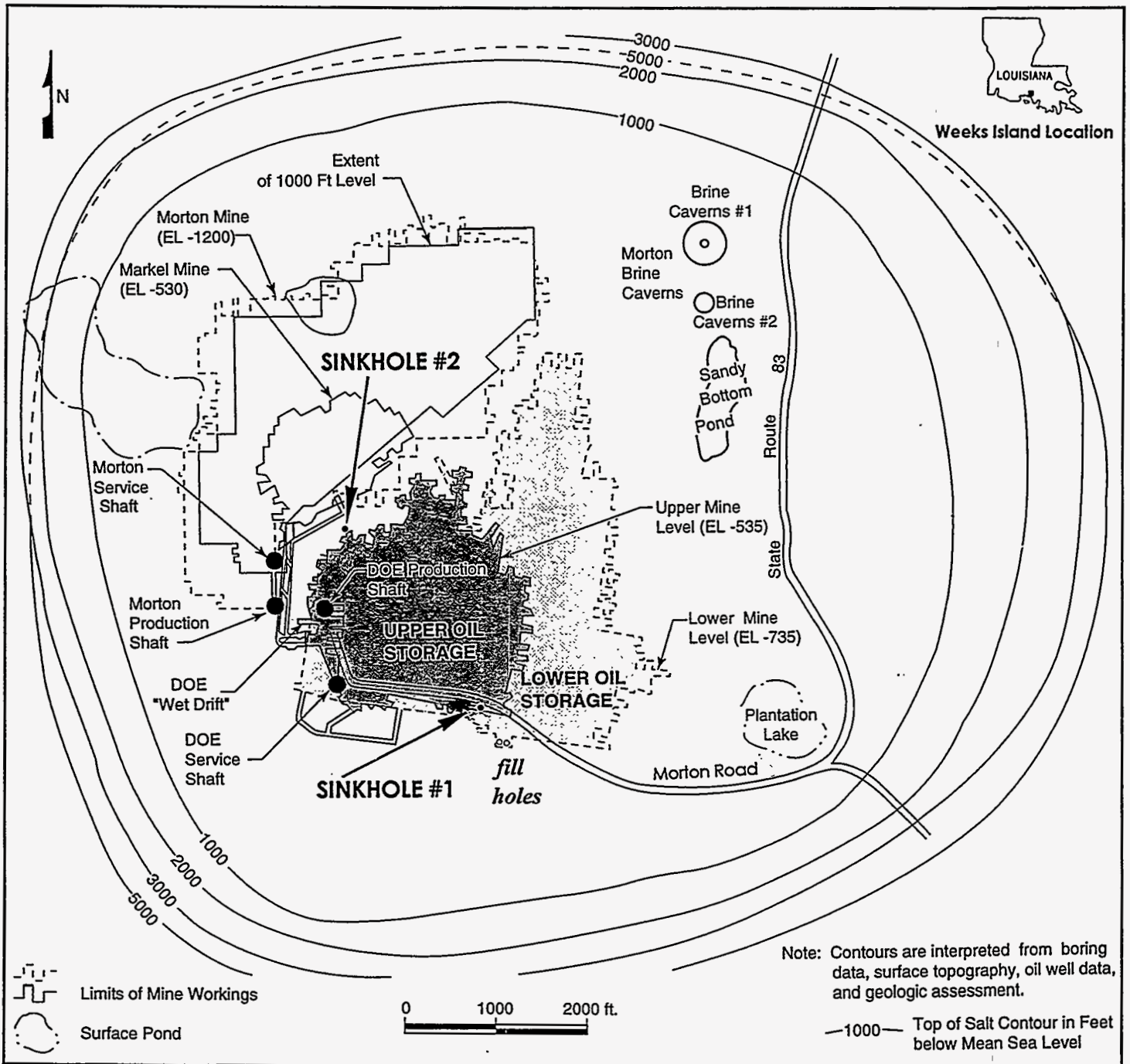

Figure 2 Weeks Island salt dome, Louisiana, showing location of the two sinkholes, two fill holes, mined areas, and contours atop the salt stock.

Sinkholes had formed at other mines in domal salt during the 1980's and earlier (Coates et al., 1981; Neal, 1994), and they probably also occur as a result of natural processes (Autin, 1984). The location near both the edge of the dome and probable anomalous features in the salt stock, including a valley on the top of salt (Fig. 7), suggested that an entirely natural origin was possible, or at least influential, (Neal, et al., 1993), although Martinez (1992) insisted from the beginning that mine-induced factors were likely involved. During the original mining, black salt, gas blowouts, and minor brine seeps were noted beneath the vicinity where the sinkhole developed, and Magorian (1987) later mapped a shear zone just south of the mine boundary. The shear zone effectively may have influenced the southerly extent of the original mining. Other influences were considered, including the location that was coincident with the former mining company townsite on Weeks Island. Subsequently, an exploratory borehole, MY06, was uncovered in Morton's handwritten records of the former operator, Myles Salt, and was found to have existed approximately 125 feet SSE of the first sinkhole. The records indicate only that it penetrated to -385 feet, without indicating it tagged top of salt. Regardless of the lack of detail in records of this borehole, there should have been some 165 feet of salt remaining over the top of the upper mine level, assuming the depth values are accurate.

A "watch and wait" position was adopted following the initial discovery, and in March 1993 fluorescein dye was placed in the sinkhole as a means of detecting connections with the underground mine, or to the

surface downdip of the sinkhole. But by mid-1993 it was visually apparent that the sinkhole was deepening and had nearly doubled in volume, and monitoring data suggested that the brine influx into the mine was also increasing. The evidence for increasing dissolution caused sufficient concern by late 1993 to initiate a more detailed diagnostic study. Engineering planning was also initiated to address actions to decrease the risk to continued oil storage, and possible relocation of the inventory to other sites. The sinkhole was filled with sand in March 1994 because its depth of more than 40 ft and location only 50 ft from the main access road clearly was hazardous.

Water inflow into the mine was suggested by continuous and increasing amounts of brine in the fill hole sump. While not a precise measurement, over several months in early 1994 the inflow trend increased from one to nearly three gallons per minute. This inflow increase was noticed almost immediately following filling of the sinkhole with sand in March 1994; the sinkhole continued to deepen at a rate averaging about two cubic yards per day, requiring new fill weekly (Table 1; Figs. 3, 4). This suggested that dissolution was ongoing, and there was reasonable correlation with the amount of increasing brine that was observed in the fill holes and the increasing sinkhole volume. In late July 1994, in an effort to reduce solutioning, saturated brine was injected just below the salt interface and almost no additional subsidence has occurred since the introduction of brine began. The further dissolution of salt was virtually arrested, marking the first time that such mitigation of a sinkhole in salt had been achieved without

DATE	Cubic Yards	Total	Yd./Day
11-Mar-94	778	778	
16-Mar-94	157	935	
01-Apr-94	19	954	1.06
20-Apr-94	16	970	
21-Apr-94	4	974	1.00
28-Apr-94	18	992	2.57
03-May-94	18	1010	3.60
11-May-94	18	1028	2.25
19-May-94	15	1043	1.88
27-May-94	18	1061	2.25
06-Jun-94	18	1079	1.80
13-Jun-94	19	1098	2.71
20-Jun-94	21	1119	3.00
27-Jun-94	18	1137	2.57
12-Jul-94	17	1154	1.13
20-Jul-94	19	1173	2.38
25-Jul-94	18	1191	3.60
12-Aug-94	18	1209	1.00
14-Dec-94	3	1212	0.02
05-Jun-95	0		

Table 1 Volume of sand fill placed in Sinkhole #1 from March to December 1994.

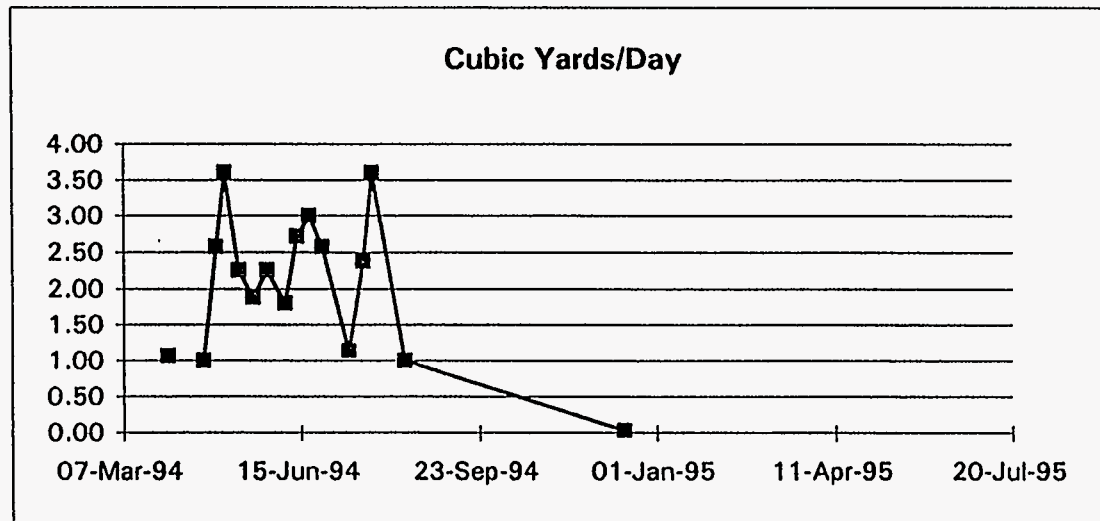
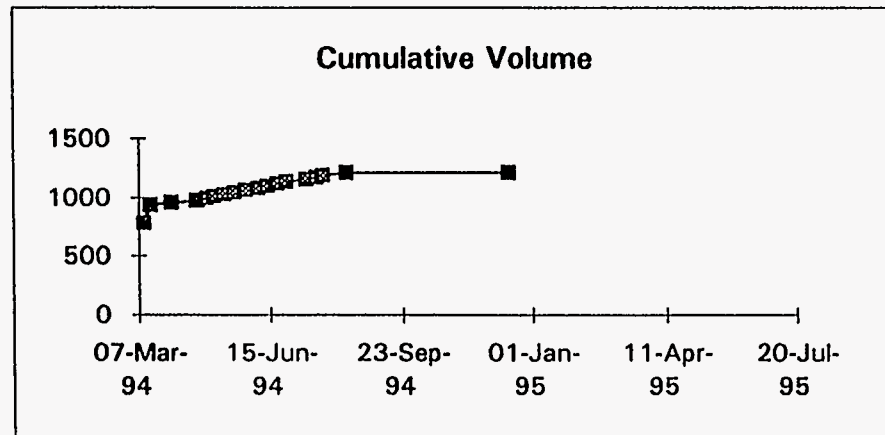

Figure 3 (top) Cumulative volume of sand fill vs time at the first sinkhole, showing virtual stop of subsidence in August 1994, coincident with injection of saturated brine into sinkhole throat.

Figure 4 Rate of sand fill added to the first sinkhole, following initial fill in March 1993. Average fill was approximately two yards per day, an amount roughly equivalent to observed brine inflow rates into the fillhole sump and assumed salt dissolution below the sinkhole.

downhole grouting. The total sand fill now exceeds 1200 cubic yards, but no sand has been added since December 1994.

SINKHOLE DIAGNOSTICS

A combination of geophysics, drilling, and hydrologic studies were undertaken in early 1994 to provide information necessary to establish appropriate DOE action and schedules, consistent with perceived environmental risks. In addition, analytic salt mechanics modeling and solutioning processes were applied to complement the field data. A variety of geophysical and geochemical methods which proved of only limited usefulness were also employed to gain diagnostic information.

Seismic reflection profiling identified an apparent deflection in the reflector near the sinkhole center that at first was thought to be a hydrologic cone of depression. Later detailed study showed this reflector was more apt to represent a structural or material discontinuity (Miller et al., 1996). But the perceived anomaly led the way to obtain during the fall of 1994 detailed hydrologic data that showed a piezometric surface, flat and near sea level, within highly permeable sediments of the ancestral Mississippi River delta (ViroGroup, 1994).

Cross-well seismic tomography was conducted across the throat of the sinkhole through separate wells constructed in each of the four quadrants outside the sinkhole. The borehole locations in competent high-velocity salt confirmed an essentially vertical sinkhole structure at depth (Harding, 1994). The velocity tomograms showed a distinct low-velocity zone typical of saturated sedi-

ments below the surface sinkhole but failed to reveal detailed throat geometry.

Self potential (SP) surveys, which had showed hydrologic streaming potential at another mine sinkhole locality in New York, were attempted at Weeks Island. Although apparent anomalies were measured near the sinkhole, their cause was unclear, but were interpreted to show downward hydrologic flow along a planar sheet.

Gas mapping of trace concentrations of near-surface soil gases was conducted in 1994 as a way to test connectivity with the SPR mine, or with anomalies originating from within the salt. Specific gases, hydrogen and methane plus other light hydrocarbons, can originate in the oil, from trapped zones within the salt, or from surface microbial activity. Although gas survey data did profile some anomalous areas around the sinkhole and a nearby shear zone, this study did not reveal definitive diagnostic information relevant to the sinkhole or other potential sinkholes (LSU, 1994). Elevated levels of soil gases were found and associated with suspected anomalous salt zones, particularly over the edges of the SPR salt mine. Significantly elevated areas of hydrogen, methane, plus some ethane, were found over anomalous shear zones in the salt, particularly in locations over previously identified gas outbursts in the salt. Specific gas survey results were interpreted as representing a surface expression of an anomalous zone in the salt that had been identified in the mine prior to SPR operations (Carney et al., 1995). There was also an apparent correlation of soil gas anomalies with possible increased salt dilatancy related to mine structures.

Slanthole drilling directly into the sinkhole throat below the top of salt provided the most direct confirmation of dissolution geometry as evidenced by drilling boreholes BH-7A and BH-9 (Fig. 5). *Slanthole BH-9*, adjacent to the sinkhole, was drilled at a high-angle approach directly over the top of the subsurface extension of the surface sinkhole expression. It extended below the top-of-salt elevation encountered in the tomography holes and directly over the sinkhole throat. This wellbore provided the opportunity in July 1994 for injection of rhodamine dye directly into the throat of the sinkhole at 262 ft depth, in addition to the fluorescein dye that was placed in the surface sinkhole in March 1993, a year prior to filling it. Either dye, if detected in the fill hole sump, would have provided unequivocal evidence of hydrologic connection with the mine. Neither dye was detected in the mine until February, 1996, when fluorescein was confirmed in the fill hole sump.

Slanthole BH-7A was started at 60° inclination from horizontal and aimed at the sinkhole throat within the salt at depth. It penetrated the top-of-salt at the normal depth of 185 feet and then continued on through salt into a major sand-filled void below the top of salt that was approximately 7 ft wide and at least 72 ft deep. A 3-D *In Situ Permeable Flow Sensor* was installed in the sinkhole throat and operated for two weeks (Bauer et al., 1994; Ballard and Gibson, 1995; Ballard, 1996). The data indicated essentially vertical flow down the throat, at 1 ft/day. In addition, a downward movement of about 1 inch per day of the flow sensor itself also indicated that sediment was moving down the throat, presumably in

response to dissolution of salt by undersaturated groundwater at some point below. This borehole also enabled additional injection of rhodamine dye, similar to that emplaced in BH-9, which again was not detected in the periodic fill hole brine monitoring.

Hydrologic investigations were conducted in the immediate vicinity of the sinkhole during the fall of 1994 with construction of six new test wells M-1, 2, 4, 5, 6, 7, and the perforation of the BH 3-6 casings (ViroGroup, 1994). Aquifer uncertainties existed following the seismic reflection surveys and the geophysical logging, and with a single, questionable laboratory permeability determination. Reliable aquifer properties were needed for engineering decisions concerning grouting efficiency and for modeling input to use in risk assessments. The results showed extremely high permeabilities, with a very flat piezometric surface near sea level. With composite permeabilities on the order of 60 darcies, the ability to measure influx into the sinkhole as a warning indicator would be unlikely (Ostensen, 1995a). The permeability data combined with the uncertain geometry of the sinkhole also suggested to grouting specialists that forming a plug in the sinkhole conduit would be impractical, if possible at all.

Slanthole EH-1, at 90° to BH-7A, transected an 18 ft-wide sand-filled void at about the same depth (~260 ft), further defining a cross-section elongated in the direction of the mine boundary. *Slanthole EH-2* between EH-1 and 7A did not enter the void, even after several offset attempts. *Slanthole EH-3* intersected the void from the opposite (east) side, with lateral dimensions of

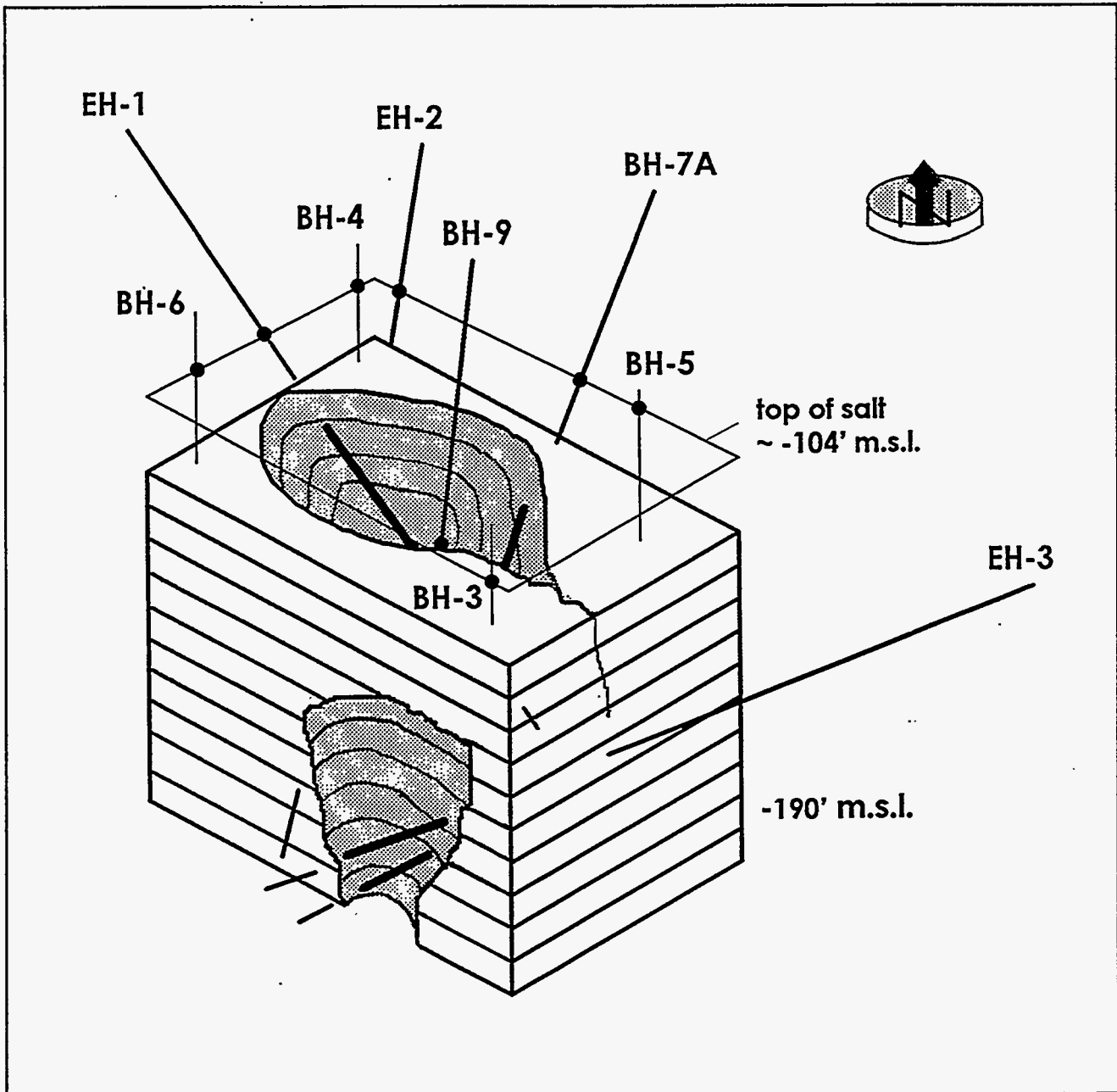

Figure 5 Diagrammatic representation of exploratory drilling and geometry of the first sinkhole throat. Boreholes BH-3, 4, 5, and 6 were drilled for crosswell seismic tomography; slantbores BH-7A and 9 were drilled for throat definition. EH-1, 2, and 3 further defined the throat and provided decisive information regarding grouting potential. Accentuated portions of boreholes define throat penetrations.

15 and 10 ft at two different depths. The drilling indicated a very irregularly shaped dissolution feature, but with essentially vertical dimensions directly below the sinkhole. Sand samples recovered from the sinkhole throat in EH-1 and BH-7A showed concentrated rhodamine dye saturation. Even though throat sand samples recovered from EH-3 and an EH-3 sidetrack showed no dye saturation, it was determined to be hydraulically connected based on flow meter response in BH-9, 90 ft above, during attempts to place a flow meter below in EH-3. Evidence from elsewhere suggested that rhodamine was absorbed by sand, so additional fluorescein dye was injected at depth into the throat in EH-3 in January 1996. This time the dye was detected in the fill holes in 21 days, confirming the hydraulic connection between sinkhole and mine. Although earlier dye dispersion calculations had predicted that it could take weeks or even a year or more to reach the sampling point (Linn and Hinkebein, 1994), the absorption of rhodamine by sand and brine and/or oil appears to be the principal reason that it did not appear in the fill hole sump. It is uncertain whether the fluorescein seen in the fill hole was that placed in the sinkhole in March 1993 (8 lbs.), or that placed in EH-3 in January 1996 (42 lbs), but reason suggests the latter.

Brine hydrochemistry is frequently analyzed in salt mines to distinguish water of meteoric origin from that of connate origin. At Weeks Island a decided change in the composition of stable isotopic ratios was evident in comparing 1993 water from the fill hole sump with that obtained in late 1991, about the same time postulated for the sink-

hole origin (Knauth, 1994). Although inconclusive, earlier isotope ratio trends suggested that a smaller leak may have existed as early as 1987 (Fig. 6). These long-term isotope trend values in the fill hole samples reveal a gradual change, showing that the water is becoming increasingly meteoric and suggesting dilution by ground water.

Mine fluid mass or volume balance, while potentially useful in determining brine inflows at locations other than the fill hole sump, could not be used in the Weeks Island SPR. Unlike other mines where leaks can be observed underground, the SPR must rely on indirect evidence such as changes in the oil/water or oil/air interfaces, increased pressure, or changed isotopic composition of the inflow dilution of the contained water at the point of accumulation. In fact, early detection of small inflow quantities are masked in interface detection by the large total quantities of fluid in the reservoir, and the detection of brine composition changes are masked by the 750,000 barrel volume, about one percent of the total fluid volume. This volume consists of the approximately 1% of bottom sediment and water contained in the crude oil in addition to the 400,000 barrels of water used to hydrotest the pipeline. These diagnostics are complicated by salt creep closure, which gradually reduces the storage volume by about one-fifth of one percent per year (~160,000 barrels), a very small amount overall, but a large amount relative to the few gallons per minute generated by the leaks that could cause the sinkhole(s) to form.

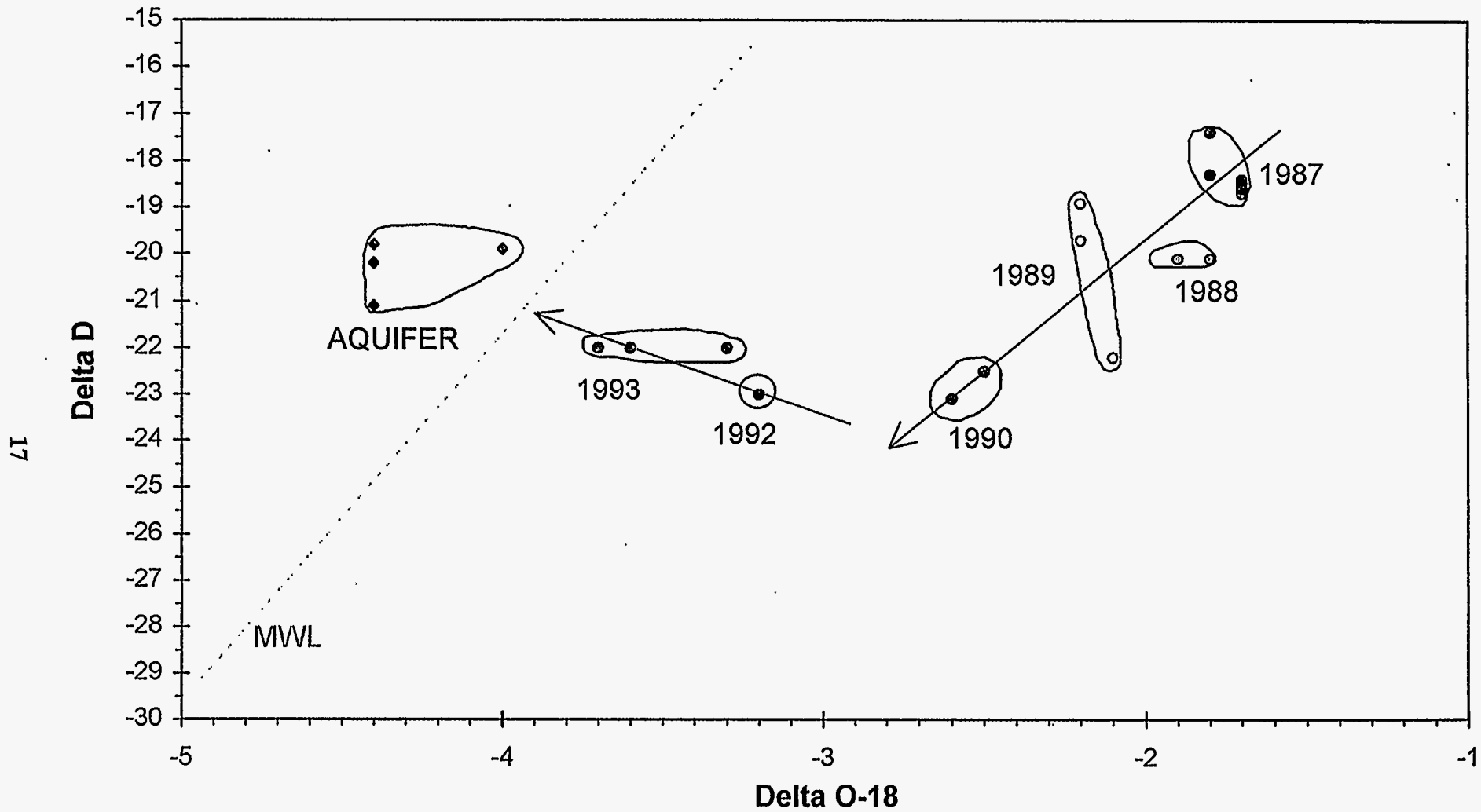

Figure 6 Isotopic evolution of brine taken from fill holes, 1987-1993, showing trend from connate to meteoric, with a significant change occurring in about 1991, approximately the same time of formation of the first sinkhole. The analyses plotted here show the rate of change in hydrogen (D, deuterium) vs ^{18}O (oxygen) stable isotopes.

CAUSAL FACTORS

Anomalous features in the salt stock have been considered as possible factors in initiating the sinkholes. The southern limit of the mine was apparently influenced by the nearby intersection of anomalous salt features, specifically gas outbursts, brine seeps, and black salt. Thoms and Gehle (1995) point out that a zone of black salt, an anomalous feature, was mapped by Kupfer during mining near the location of the sinkhole. Brine seeps were also mapped near the subsequent sinkhole location, and although at the time judged not meteoric in character, the brine chemistry showed some deviation from normal connate analyses (Martinez, 1995). Thoms and Gehle (1995) suggested that an association of factors probably produced leak-prone areas that may be responsible for sinkhole formation at Weeks Island.

Rock mechanics modeling of the mine as a two-dimensional continuum by Ehgartner (1993) showed that the areas near the mine perimeter would be in tension and that fractures in the top of salt could have formed as early as 1970 (Figs. 7, 8, 9). The analyses indicate that the cracks initiate at the top of salt and grow toward the mine because of bending and stretching of the salt as a result of creep closure. Such cracks could be exposed to undersaturated ground water and gradually enlarge at the same time the crack was extending toward the mined openings. Sampling of subsurface water shows brine is undersaturated at distances greater than 4-5 feet above the top of salt. The modeling results established a reasonable mechanism for eventual incursion of groundwater and are also validated by sur-

face survey data showing subsidence over the mine, which is in close agreement with values from Ehgartner's modeling. Comparable modeling by Nieland et al. (1994) later showed similar results, but also concluded that the natural weaknesses may have influenced the results.

This rock mechanics mechanism of deformation was substantiated using a 3-D model developed by Hoffman (1994). His analyses predicted tensile zones similar to Ehgartner's 2-D model, particularly over the vertically-aligned edges of the upper and lower mine levels. In addition, a dilatant zone (Figs. 8, 10) was predicted, using a criterion developed from previous rock mechanics tests on Weeks Island salt by Ehgartner (1994). The dilatant zone was predicted to extend from the top of salt to the edges of the mine. Dilatancy is characterized by increased porosity, hence permeability, caused by microfracturing. Thus the time-dependent mine subsidence results in tensile and dilatant zones that potentially explain the groundwater incursion into the mine. With both sinkholes occurring almost exactly over aligned levels of the mine, the mechanisms explained above are credible, independent of the presence of anomalous geologic features.

The deviations from "normal" geologic conditions noted above by Thoms seem to support the notion of *susceptible salt zones* influencing sinkhole development at the initial location. However, no sinkholes have been observed along the unaligned levels on the east boundary of the mine (even though it is a zone of gas outbursts, etc.). Thus the primary causal factor is most likely the mechanics associated with mine subsidence.

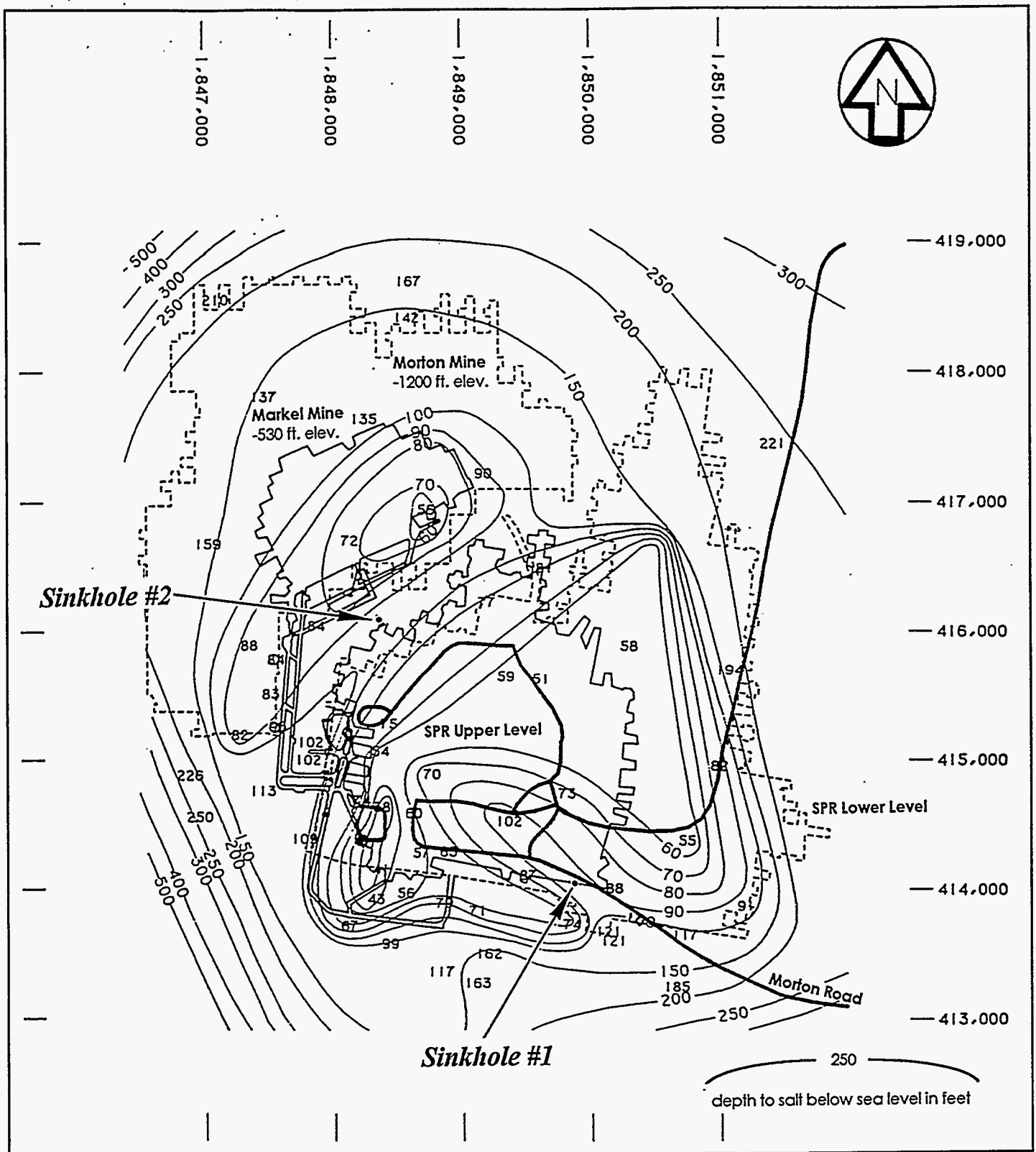

Figure 7 Top of salt contours with detail over mined openings. Sinkholes 1 and 2 are located in apparent troughs, possibly separating individual lobes or spines (from Acres, 1987; SAND87-7111).

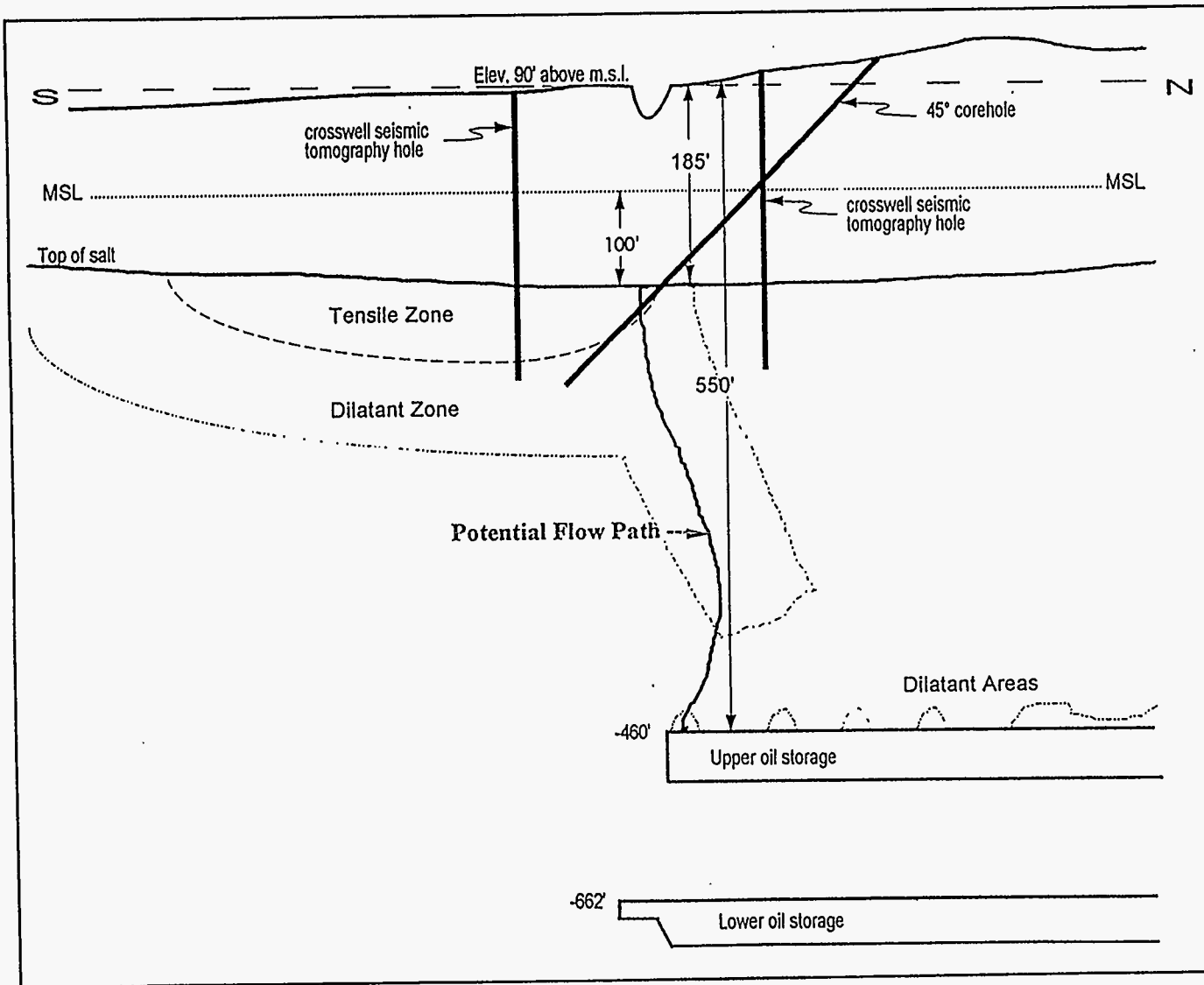

Figure 8 Geomechanical modeling by Ehgartner (1993) and Hoffman (1994) showed mechanism for crack development in tension that would develop over mined openings after a number of years, and progressing through weakened dilatant zones. Based largely on the results of this modeling, crosswell seismic tomography was conducted and angled boreholes were planned to intersect such features.

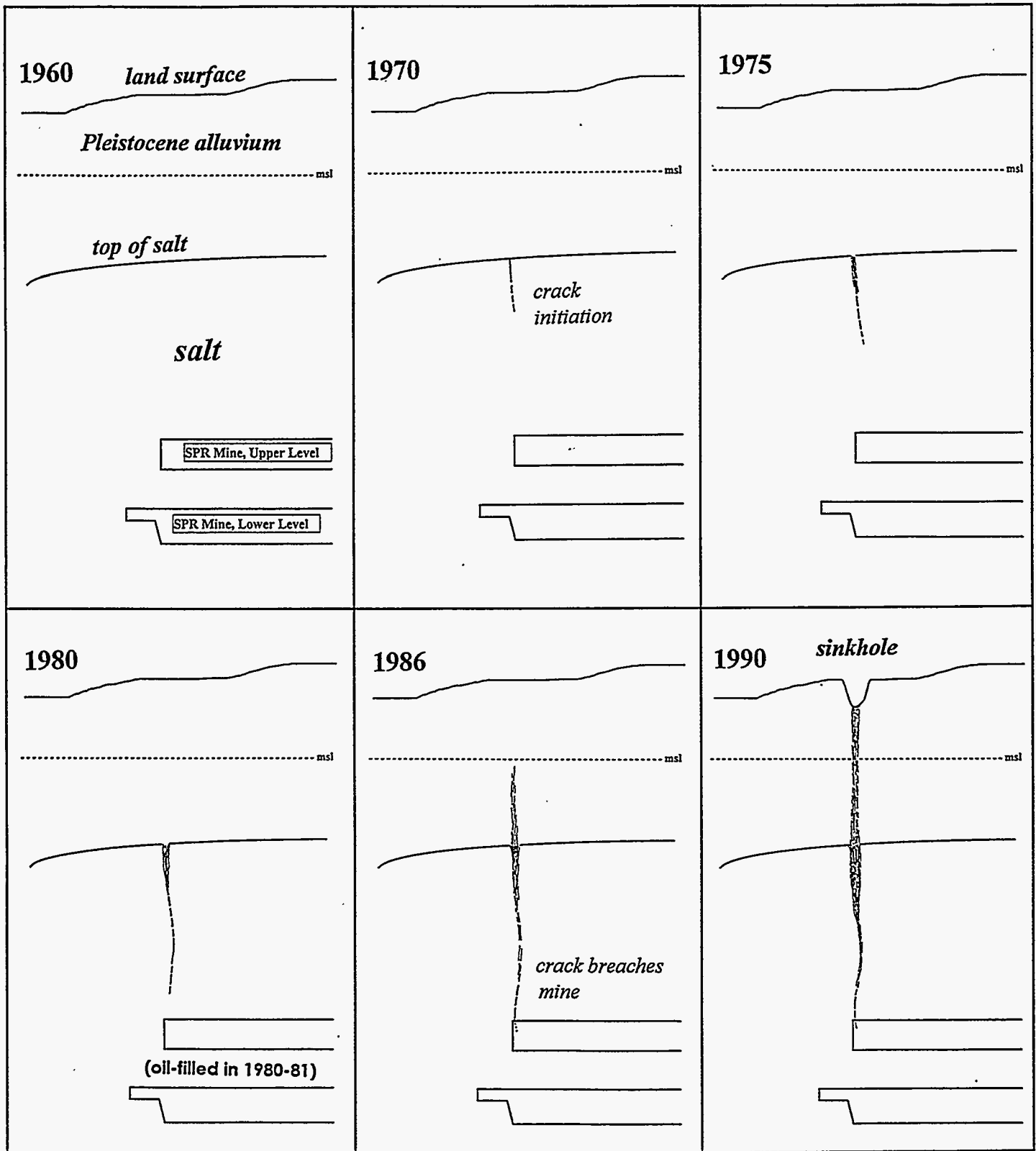
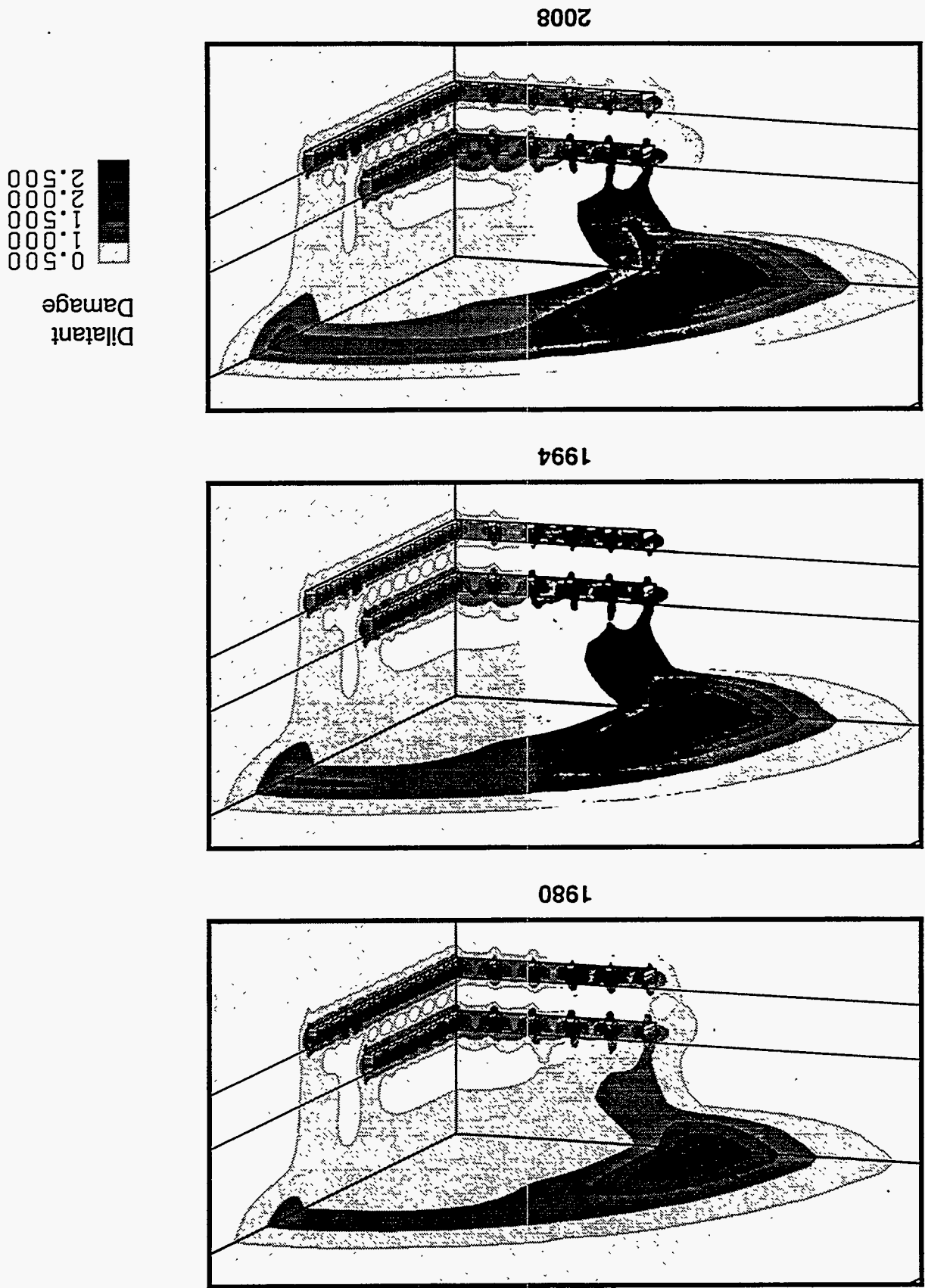

Figure 9 Conceptual development of Weeks Island sinkholes, based on geomechanical modeling and presumed hydrologic connection with undersaturated groundwater. Sinkhole #1 was first observed in 1992, but likely took years to develop. After tension crack(s) formed ca. 1970, progressive enlargement of a dissolution channel (s) occurred but a sinkhole did not manifest until about 1990-91. The second sinkhole was first observed in early 1995.

Figure 10 Dilatant damage at simulated times corresponding to: 1980 (oil fill), 1994, and 2008. Damage is indicated where $D > 1.0$.



SINKHOLE MITIGATION: BRINE INJECTION; FREEZE- WALL CONSTRUCTION

Following the slant hole drilling, with knowledge that the surface sinkhole was connected to a sand-filled conduit through the salt directly beneath the sinkhole, and that both the sand and the brine in the conduit were moving downward with substantial velocities, the hypothesis that the sinkhole was hydrologically linked to the mine gained credibility. The case was sufficiently strong and the potential consequences sufficiently detrimental that a programmatic decision was announced in December 1994 to relocate the oil inventory as quickly as possible.

It was generally recognized that the mechanism responsible for sinkhole growth involved fresh water from the aquifer above the top of salt flowing down the sand-filled conduit and dissolving salt on its way down to the mine. If the flow of fresh water down the conduit could be inhibited, the potential for salt dissolution would be reduced and the rate of growth of both the size of the sinkhole and the flow rate down the sand-filled conduit slowed dramatically. Diamond and Mills (1994) suggested that saturated brine be injected deep into the sand-filled conduit at a rate higher than the rate of flow downward to the mine. The result would be that only saturated brine would flow downward in the sand-filled conduit, thereby drastically reducing salt dissolution, the sinkhole growth rate, and the rate of increase of the downward flow into the mine.

Beginning in August 1994 and continuing to the present, saturated brine has been injected into one or more of the slant

boreholes which intersect the sand-filled conduit at depth (BH-7A, EH-3, and EH-1), initially at three gpm and increasing to about five gpm as of July 1996. Brine injection has been very successful in that further growth of the sinkhole, as measured by the need to continue adding sand to it, has been virtually arrested (Figs. 3, 4).

To monitor the hydrologic effect of brine injection, an In Situ Permeable Flow Sensor (Ballard and Gibson, 1995) was placed at the bottom of borehole BH-9 in October 1994. The probe was located within the sand-filled conduit about 10 feet below the top of salt, and measured the flow rate of brine up and out of the sand-filled conduit (excess brine injected below in BH-7A). Flow data from this probe allowed the flow rate of brine down the sand-filled conduit from the brine injection point to the mine to be calculated from the difference between the brine injection rate deep in the sand-filled conduit and the flow rate up and out of the sand-filled conduit at the top of salt. These values were in good agreement with mine inflow rates measured in the fill hole sump, strengthening the hypothesis that the sinkhole was in fact hydrologically connected to the mine. Both measures of the flow rate down the sand-filled conduit increased steadily during the early part of 1995, from about two to three gallons per minute and then flattened out during the summer (Fig. 11).

The injection of brine into the throat and concomitant slowing of dissolution has altered the natural hydrologic environment in significant ways. Had this not been accomplished, the sinkhole growth rates would have progressed (Russo, 1994). The risks of

BRINE INJECTION and FILL HOLE SUMP INFLOW

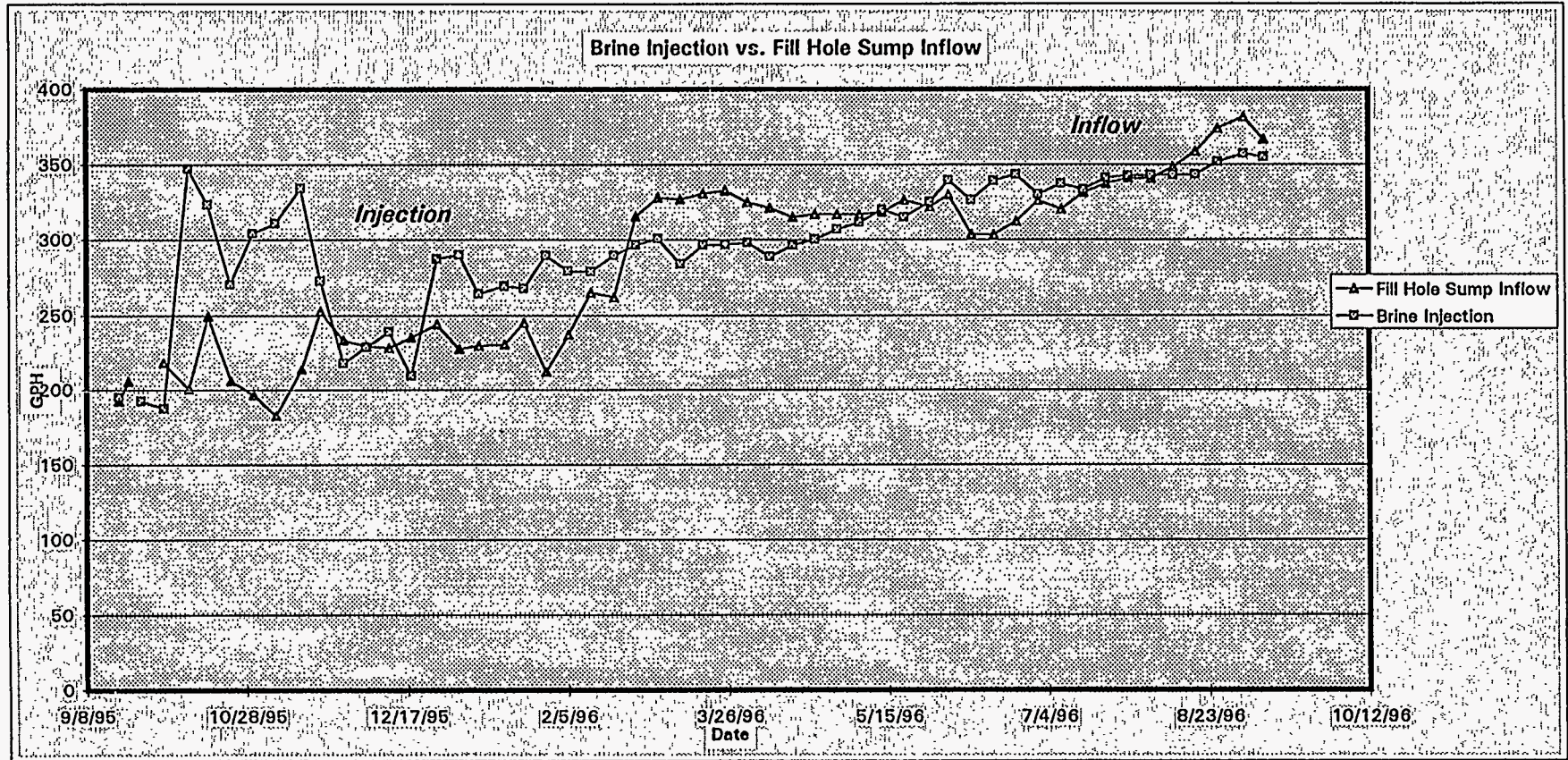

Figure 11 Comparison of brine inflow rates into fill hole sump with brine injected into sinkhole throat. Respective values and generally increasing trend are similar, suggesting possible correlation with regard to origin.

sinkhole collapse have been calculated in Florida limestone karst on the statistical basis of collapse frequency vs area (Beck, 1991). Such analyses are inappropriate for Weeks Island because of dissimilar geology, but the very existence of the second sinkhole confirms the continuing progression of developmental processes.

As plans to move oil were being formulated in early 1995, a second and smaller sinkhole was identified on the northwest boundary of the mine in a geologic and stress-field environment similar to that of the first sinkhole. The second sinkhole probably first appeared in late 1993, based on field appearance and aerial photographic evidence (Neal, 1995b). Although the second sinkhole was only 14 ft in diameter and 10 ft deep, its occurrence confirmed the progressive development of causal processes and the necessity of expedient mitigation. It was filled with sand and shows continuing very slow growth, as measured by weekly surveys of a monument placed in its center. Some 18 months after the initial observation, in mid-August 96, an additional, sudden collapse of 3.9 feet was observed, raising the total collapse volume to nearly 50 cubic yards, still very much less than the first sinkhole. Such episodic collapses are similar to what was observed in the first sinkhole over the first 18 months after initial observation, substantiating the continuing progression of sinkhole development.

As the progression of sinkhole causative factors seemed inevitable, the long-term effects of brine injection unknown, and the increasing risks of surface collapse during oil removal unacceptable, the plan implemented by DOE in late 1994 included the

construction of a freezewall around the principal or first sinkhole. The freezewall was intended to form a barrier to limit hydrologic inflow in the event of catastrophic increase in the mine inflow rate (DOE, 1995b). The construction of the freezewall began in June 1995 and was completed within five months. The wall was formed by chilling calcium chloride refrigerant to an average temperature of -38°C (-36°F) and circulating it in 54 wells constructed in three circumferential rings in and around the sinkhole. The outer ring of twenty-two wells with a diameter of 54 ft was drilled approximately 10 feet into salt (-125 ft MSL) to anchor the freeze wall into the salt stock. The middle ring of twenty-two wells with a diameter of 48 ft was drilled at or slightly into the salt (-115 ft MSL). The inner ring of 10 wells with a diameter of 40 ft was placed at the top of the salt. Five of the inner ring of wells did not tag salt and are assumed to be in the area of the sinkhole cavity. Installation of the freeze wells included the innovative use of a movable rig platform straddling the sinkhole and mounted on rails outside the well area. This allowed freezing to commence on the outer ring while the inner ring wells were being drilled and prepared. At times, there were three drill rigs in operation simultaneously within the relatively small area.

The freeze wall was declared integral and ready to test by the subcontractor on October 15, 1995, but tests failed to confirm hydrologic isolation. Freezing continued and thermal profiles indicated that the desired integrity was achieved on November 1, 1995. The testing provided reasonable confirmation that an essential hydrologic barrier had been achieved and on November 6th the

freeze wall was declared ready to support drawdown, which commenced two days later.

The final configuration of the freeze wall for drawdown was an ice cylinder 20 feet thick with a nominal outside diameter of 70 feet. Continued freezing formed an essentially cylindrical icewall in the zone of saturated ground water between the ground surface and the top of salt. The brine levels in the freeze wells were modified in April 1996 to concentrate freezing at the lower depths, near the top of salt (-80 to -125 ft MSL). The resultant "ice cap" (plug) functions similar to the ice wall cylinder, but requires less energy to maintain. This cap will be maintained until the crude oil storage chambers have been emptied of crude oil and filled with brine, scheduled for June 1998.

The oil is being drawn down before filling the mine with brine and permanently sealing the accessways and piping systems. During this drawdown and relocation process, which began on November 8, 1995, concerted efforts to identify the formation of new sinkholes are being made by quarterly inspections of the mine perimeter at the surface.

GEOTECHNICAL RISK EVALUATIONS AND MODEL- ING, 1995

In 1995, Sandia carried out new geotechnical risk evaluations (Molecke and Bauer, 1995a, b), specifically identifying and ranking the potential risks inherent in removing the oil, developing and maintaining the freezwall, the feasibility and effectiveness of maintaining the brine injection system, the

risks in backfilling the mine with brine, and the overall long-term environmental risk. The purpose of this risk assessment was to assist in contingency planning during the time of oil removal, brine backfill, plugging of mine openings and abandonment of the site, and to support the Environmental Assessment process under the National Environmental Policy Act (NEPA). As in previous assessments, the Delphi methodology was employed, with "technical expert" opinion solicited from persons familiar with the Weeks Island sinkhole. To enable focusing and organizing topics, the potential risks were separated into pre-withdrawal, withdrawal, and post-withdrawal periods. The results supported the DOE perception that there were significant risks, especially during the oil withdrawal period.

Two supplemental assessments followed (Molecke and Bauer, 1995c, d) which specifically assessed the environmental issues. These provided data for alternative comparisons for environmental permitting. The results also were used in the development of a long term monitoring plan for the site following decommissioning, and in the immediate development of a detailed contingency response plan (DOE, 1995c). This plan identified immediate response actions and existing documentation that addressed emergency or non-planned situations that could occur during the oil removal, brine backfill, and overall decommissioning process.

In addition to the formal risk evaluations, Ostensen (1994) followed up the brine inflow modeling with a series of calculations on potential oil outflow from the repository. He first conducted a series of porous flow

calculations at various mine pressures up to hydrostatic, with a series of plausible assumptions about the structure of the potential leak path. His results indicated that oil outflow would probably be insignificant for mine pressures up to the oil-static point and, for an unpressurized mine, the oil outflow rate for all pressures up to hydrostatic should be less than a tenth of the potential water inflow rate into the mine. Ostensen also calculated estimates of oil leakage after a hypothetical washout, i.e., failure of the sinkhole with subsequent massive water inflow, into the oil-filled Weeks Island mine (Ostensen, 1995b, c). He concluded that a major washout would not lead to formation of an oil-water siphon, so oil would not be forced all the way to the ground surface. The oil would be contained within the freezeway, or if the freezeway was not structurally sound above the aquifer (groundwater-saturated sediments), the oil could flow into the surrounding sediments. To further minimize the extent of aquifer contamination, four booster pumps in the Service Shaft were relocated to the top of the upper storage chamber to allow pumping at relatively high rates if the lower areas flood.

OIL RECOVERY AND BRINE BACKFILL OPERATIONS

The crude oil drawdown plan for Weeks Island requires removal of as much crude oil as is practical and possible using the site's drawdown pumping equipment. Uncertainties associated with the geometry of the storage chambers, loose salt located on the floor of the mine, unknown volume of fresh water discharged into the mine after

pipeline integrity testing, and limitations of the pumping system will result in an estimated amount of crude remaining in the mine after initial drawdown to be in the range [0.75 to 2 million barrels]. Recovery of this remaining crude will be accomplished in four phases, which are linked with the filling of the storage chamber with brine (Walk, Haydel and Associates, 1996).

Phase I involves removal of crude oil entrained in the loose salt on the floor of the lower chamber and crude trapped in areas that prevented flow to the pumps. The expected amount of crude recoverable in this phase is between 0.5 and 1.0 million barrels, depending on the geometry of the lower level and the amount of loose salt on the floor. Initial brine injection will allow crude oil entrained in the salt and located in low areas to flow to the pumps. The crude oil displaced by brine will be pumped via SPR pipeline to the Bayou Choctaw storage site and injected into an SPR cavern dedicated to storing sour crude. Natural separation of the oil and any entrained brine will occur in the cavern. This process will continue until the Service Shaft sump is flooded by brine. Brine injection will then proceed until the mine floor is flooded with brine. At this point, a decision based on cost, schedule, and the estimated amount of crude oil layered on top of the brine will be made to either pump brine from the mine to Bayou Choctaw in order to remove additional crude oil with the mine booster pumps, or to progress to Phase II for the lower-rate skimming operation.

Phase II begins the oil skimming and concomitant brine injection operations, the latter of which will take approximately 210 days after the completion of Phase I. The

lower storage chamber will be filled with brine to near the ceiling (-675 ft). Four skimming pump systems will be lowered through pump casings that have been or will be cut at predetermined skimming depths. These pumps will skim the layer of oil on the brine surface. The crude oil will be pumped to the Shell Oil Co. terminal located on the Intracoastal Waterway and transported to a terminal for ultimate injection into a sour crude oil cavern at Big Hill. The separated brine will be returned to the Weeks Island mine. It is estimated that up to 0.5 million barrels will be recovered during this Phase II, expected to take up to 60 days.

Phase III skimming will commence after the brine level in the mine is raised to -531 ft (about five feet below the Service Shaft access ceiling), approximately 45 days after Phase II is completed. The crude oil will be skimmed in the same manner as Phase II, recovering oil from the upper chamber floor. The Phase III skimming is expected to take about 60 days.

Phase IV will commence after the mine storage chamber has been filled with brine to the -474 ft level. The skimming operation will be similar to Phases II and III, except that a single skim pump will be placed in the mine vent hole. It will be operated as needed throughout the remainder of the Weeks Island decommissioning process, or until June 1999. This phase is expected to recover all available crude oil from the vicinity of the sinkhole, so that when the ice cap is allowed to thaw, crude oil is not expected to flow from the sinkhole leak path.

The oil recovery operation is expected to capture all but about 20,500 barrels, or 0.03% of the 72.5 MM barrels of

crude in storage at the start of drawdown (Walk-Haydel, 1996).

CLOSURE AND ABANDONMENT OF MINE OPENINGS

The plan to plug and permanently abandon the Weeks Island Facility in a safe and acceptable manner includes filling the storage caverns with 85% (minimum) saturated brine, dismantling and removing salvageable downhole equipment, covering underground openings, limited regrading, and general site cleanup (PB-KBB, 1996).

The primary isolation of the oil storage chambers has been accomplished by bulkheads already in place: the Markel Bulkhead, production and service shaft bulkheads and raisebore bulkheads (Figure 1).

The plugging and abandonment tasks consist of the following:

- *Production Shaft*--Salvageable cables and pipes, etc. will be removed from the shaft. After cleaning the casings, bridge plugs will be set in the casings through the production shaft bulkhead at approximately -438 ft MSL. Cement will be placed in the casings above the bridge plugs up to the top of the pipe(s) near the top of the bulkhead. A steel cap will be welded on top of the casings. The production shaft headframe building will be securely locked after the raisebores, Markel Incline bulkhead, and the service shaft bulkhead have been plugged.
- *Service Shaft*--Salvageable material will be removed from the manifold room. All instrumentation, tubulars, and pumps will be removed from the 22 casings penetrating the service shaft bulkhead below the

ing the service shaft bulkhead below the manifold room. Salvageable cables and pipes, etc. will be removed from the shaft. After cleaning the casings, inflatable packers capable of withstanding hydrostatic pressure will be set in each casing to a depth of 30 ft below the top of the casing at approximate elevation of -380 ft MSL. The casings will be filled with expanding cement, and steel caps will be welded on top of each casing. The headframe building will be securely locked after the raisebores and Markel Incline bulkhead casings have been plugged.

- *Raisebores*--Instrumentation and tubulars from casings through both raisebores will be removed. After cleaning the casings, bridge plugs will be installed at a depth of 30 ft from the top of the casings, to approximate elevation of -414 ft MSL, and the casings will be filled in lifts with expanding cement. Steel caps will be welded on top of the casings.
- *Markel Incline Bulkhead*--Instrumentation and pipes will be removed from the incline bulkhead casing. After cleaning the casing, a bridge plug will be installed from the inboard end of the bulkhead and the casings filled with cement. A steel cap will be welded on top of the casing. The two 4-inch wetting casings will be welded with steel caps.
- *Vent Hole*--The flare system at the top of the vent hole will be removed and the Phase IV oil skimming system installed. After Phase IV oil skimming the casing will be cleaned and a bridge plug will be set at an approximate elevation of -360 ft

MSL; a cement plug then will be poured in lifts to the surface. The casing will be cut at the top of the flange and a steel plate welded on top of the casing. The plugged hole will be used for subsidence monitoring.

- *West Fill Hole*--Instrumentation and tubulars from the well will be removed. After the casings are cleaned, a bridge plug will be set above the brine fill level at an approximate elevation of 400 ft MSL and expanding cement will be poured to the surface. As with the vent hole, the casing will be cut at the first flange and a steel plate welded on top of the casing to be used for subsidence monitoring.
- *East Fill Hole*--Surface tubulars will be removed. The hole will be filled with brine to elevation -18 ft MSL. The casing will be perforated between two and four feet above the top of salt, in the aquifer. A low-rate flow meter / piezometric device will be installed for monitoring purposes and will be removed in 2004, after which this hole will be plugged and abandoned similar the the West Fill Hole.

Surface facilities will be abandoned as follows:

- *Site improvements* will be transferred to the General Services Administration (GSA) except for Service Shaft fencing (removed), water wells #1 and #3 (plugged and abandoned), oily water treatment system (cleaned and demolished), and the fire truck (transferred to another site).
- *Buildings* will be transferred to GSA, with inventories, pumps, pipes, motor

controls to be transferred to another site or salvaged.

- *Process hydrocarbon systems and equipment*--Pumps will be salvaged. All hydrocarbon piping will be drained and cleaned. Accessible piping inside the fence will be demolished, piping under floors will be plugged and abandoned, crude oil piping outside the fence will be isolated, filled with inhibited water, and cathodic protection will be maintained. Inert gas generators and the flare stack will be removed and salvaged.
- *Electrical Power and Controls*--Generators, transformers, motor controls and switch gear that are not mine-related will be removed and salvaged. Power distribution and control cable conduit and tray will be demolished if above ground and abandoned if below ground. Circuits for lighting and buildings would be preserved and transferred to GSA.
- *Headframes and Hoisting Equipment* -- Headframes, hoisting equipment, and air-handling equipment will remain intact and transferred to GSA.

ENVIRONMENTAL MONITORING PLANS

Environmental protection has been a significant concern throughout the construction and operation of the SPR and is the primary reason for decommissioning the Weeks Island site. DOE published an Environmental Assessment for decommissioning the oil storage facility with attached Finding of No Significant Impact (FONSI) (DOE, 1995d) Environmental monitoring will provide assurance that the objective of maintain-

ing environmental integrity is being met. Once the oil is removed by the pumping system to the extent possible, subsequent skimming operations will remove all but about 0.03% of the total oil originally stored in the mine. The mine will then be completely filled with saturated brine and will become stabilized.

Monitoring efforts, according to the schedule shown in Fig. 12, specifically address sinkhole-related concerns commenced in 1994 and will continue through decommissioning. These efforts are summarized as follows:

Perimeter inspections were instituted in 1994 and are conducted quarterly for the purpose of identifying new sinkholes or other mine-related subsidence effects. The second sinkhole was discovered in late February 1995 during a routine inspection. Dense vegetation hindered visibility and accessibility, hence inspection effectiveness, so the upper level perimeter was cleared in 1995 and is cleaned periodically along a 100 ft-wide swath to remove new growth. These inspections are scheduled to continue through June 1999, at which time the mine should stabilize as a result of the brine backfill, making further sinkhole development highly unlikely.

Subsidence monitoring has been conducted annually since the early 1980s, beginning after the mine was filled with oil. The monitoring system was upgraded in 1990 with the addition of some 80 new monuments, several of which extend into salt. The survey data has provided the most accurate and complete subsidence data over any Gulf coast salt mine. The results define two well developed subsidence fields over

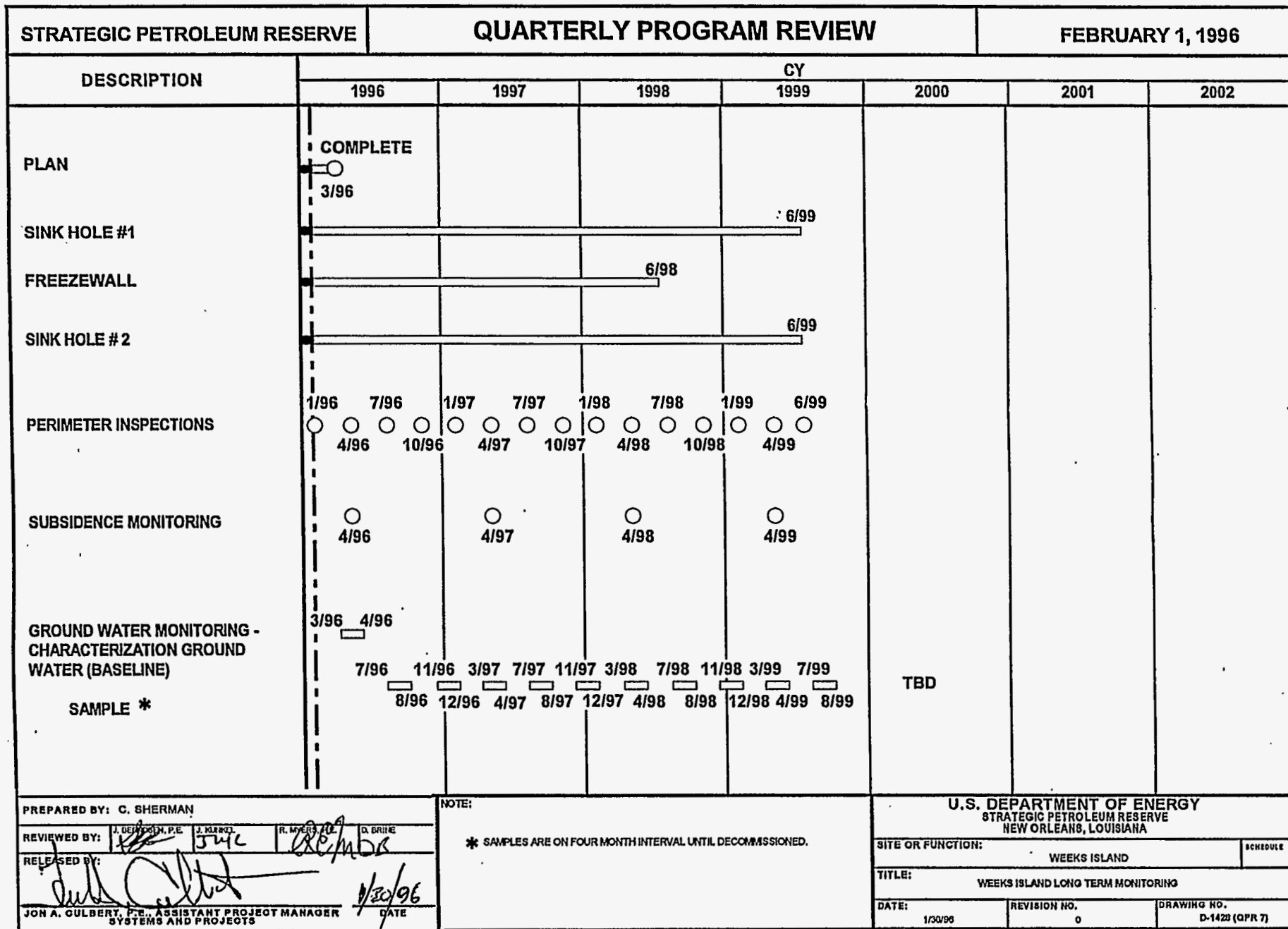

Figure 12 Timelines for environmental monitoring activities.

the SPR and Morton Mines (Nieland et al., 1994; 1994; Yeh, 1994).

Computational *mechanical modeling* has shown that once the mine is backfilled with brine, creep closure and consequent subsidence will be reduced to less than 3% of its present value and that the mine will be stable (Hoffman, 1994; Hoffman and Ehgartner, 1994; PB-KBB, 1994; Van Sambeek et al., 1994). These calculations are borne out by the experience from Jefferson Island and Belle Isle mines, since their flooding and abandonment in 1980. The monitoring of subsidence will continue through April 1999 and is expected to show that the predicted stabilization of salt creep has been achieved. The stabilized mine is predicted to close at a rate that will account for approximately 12 gal/hr or about 2,500 barrels per year (Hoffman and Ehgartner, 1994).

Hydrologic monitoring will be conducted in four wells (Fig. 12) near the first sinkhole to test for possible groundwater effects resulting from hydrocarbon leakage, or from brine effusion. Samples will be collected every four months from the monitoring wells through August 1999, and annually thereafter through 2004, testing for total petroleum hydrocarbons (TPH) on 25 ft intervals below the water table. Baseline determinations have been made following the initial sampling in April 1996.

A *creep closure / brine release* monitoring system is also planned for the East Fill Hole, consisting of a low-volume flowmeter and a piezometer to measure hydrostatic pressure. The data will be compared with modeled volumes of brine anticipated for pressure relief to the saline portions of the aquifer, estimated at about 2,500

barrels per year. Additional monitoring for TPH may also be conducted at this location.

Additional monitoring efforts are not planned as no effects on any other aspect of the total ecologic system are anticipated.

CONTINUING EFFECTS AND SINKHOLE PROGRESSION

Under the current conditions of partial oil fill, the processes of subsidence and fracturing caused by continuing salt creep around the mined openings will continue indefinitely. Once the mine is filled with saturated brine, as mine closure plans now assure, creep and subsidence rates will be considerably reduced, so there will be much less opportunity for further sinkhole development. However, additional sinkhole development would likely occur within a few years if the mine were left at atmospheric pressure.

The earlier leak in late 1978 in an area known as the "Wet Drift" (Acres, 1987) might have been a forewarning of events to come. Although in-mine and surface-based grouting controlled the leak at the time, it could just as easily have become uncontrollable and formed a sinkhole(s) then, had the appropriate mitigation steps not been taken. The location of that occurrence was also near the coincident boundaries of the upper and lower mine levels. However, at the time of the Wet Drift leaks, the technology needed to understand the mine conditions, predict future events, and thus influence management decisions was not considered.

The schedule of key events for the decommissioning of Weeks Island are shown at Figure 13.

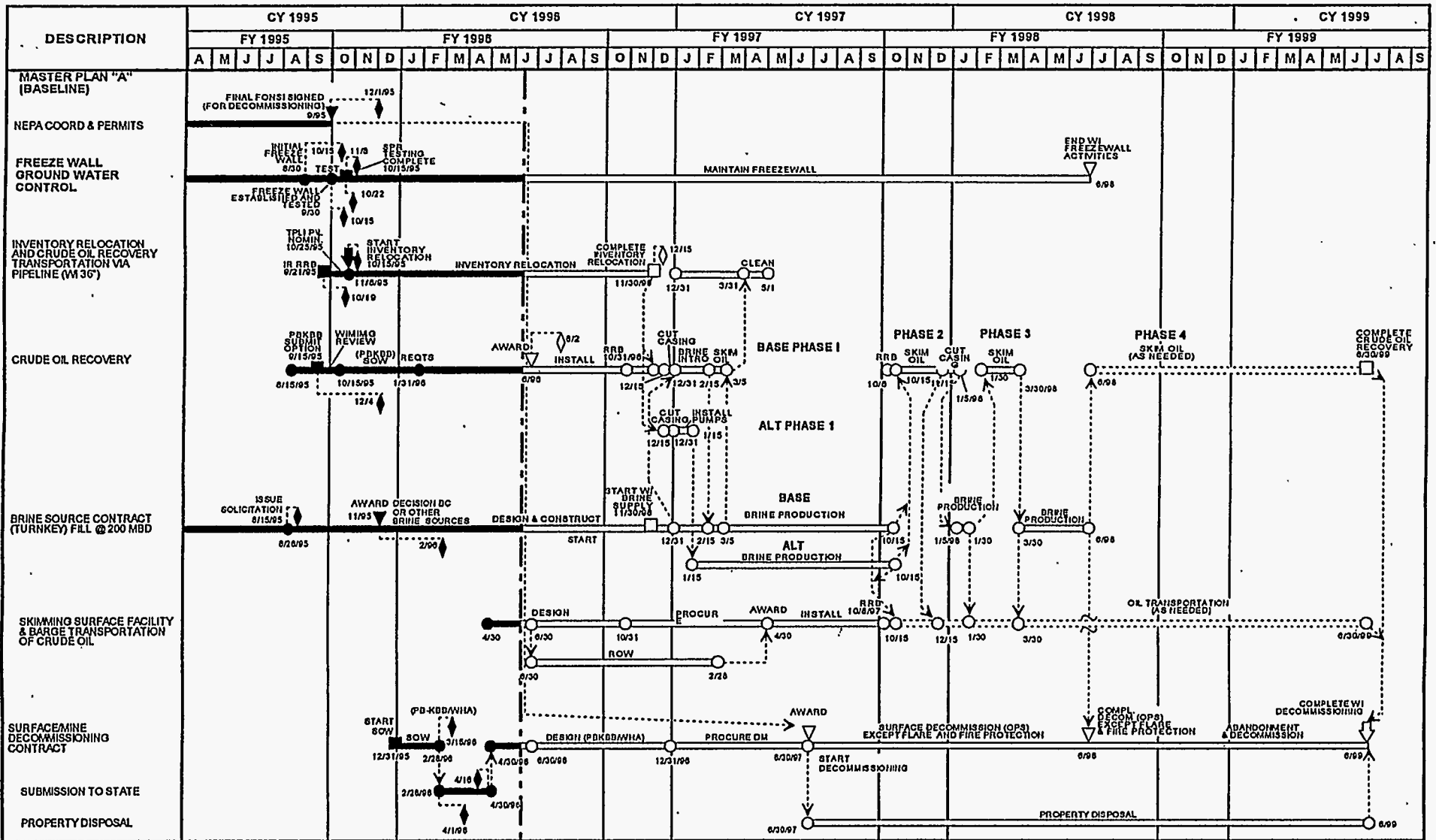

33

PROJECT MANAGEMENT OFFICE PREPARED BY: C. SHERMAN REVIEWED BY: J. BERG, J. KUHSEL, R. [Signature], D. BRINE RELEASED BY: [Signature] 7/24/96 JON A. CULBERT, P.E. ASSISTANT PROJECT MANAGER SYSTEMS AND PROJECTS		NOTE: BASELINING UNDER REVIEW	U.S. DEPARTMENT OF ENERGY STRATEGIC PETROLEUM RESERVE NEW ORLEANS, LOUISIANA SITE OR FUNCTION: WEEKS ISLAND SINKHOLE TITLE: SPR MAJOR MILESTONE SCHEDULE MINE INTEGRITY MANAGEMENT GROUP LEVEL 1, 2, & 3 MILESTONES DATE: 6/17/00 REVISION NO. 11 DRAWING NO. D-1353B (D7)
---	--	---	--

Figure 13 Overall timelines for Weeks Island key events and decommissioning schedule.

REFERENCES

- Acres American Incorporated**, 1977, National Strategic Oil Storage Program, Weeks Island Mine - Geotechnical Study. Report for Gulf Interstate Engineering Company under Contract FEA-1251-75 to the U. S. Federal Energy Administration (2 volumes).
- Acres International Corporation**, 1987. Weeks Island Strategic Petroleum Reserve geological site characterization report. Albuquerque, NM, Sandia National Laboratories Report SAND87-7111, 175 p.
- Autin, W. J.**, 1984, Observations and Significance of Sinkhole Development at Jefferson Island. Geological Pamphlet No. 7. Baton Rouge, Louisiana Geological Survey.
- Ballard, S.**, 1996, The in situ permeable flow sensor: a groundwater flow velocity meter. *Ground Water*, v. 34, p. 23-240
- Ballard, S. and J. Gibson**, 1995. Groundwater flow velocity measurements in a sinkhole at the Weeks Island Petroleum Reserve Facility, Louisiana, *in* Proceedings of the Symposium on the Application of Geophysics to Engineering and Environmental Problems. Orlando, Florida, Environmental and Engineering Geophysical Society. p 931
- Bauer, S. J. (ed.)**, 1995, Update of assessment of geotechnical risks: Strategic Petroleum Reserve, Weeks Island Site. Albuquerque. NM. Sandia National Laboratories Report SAND94-2969, 42 p. plus appendices
- Beasley et al.**, 1985, Results of a Geotechnical Risk Assessment Study of the SPR Storage Facility at Weeks Island, Louisiana Albuquerque, NM, Sandia National Laboratories Report SAND84-2072, 173 p.
- Beck, B. F.**, 1991, On calculationg the risk of sinkhole collapse, *In* Kastning. E H., Appalachian Karst, Nat'l. Speleological Soc., Inc., Huntsville, AL, p. 231-36.
- Blanford, M. L., D. J. Segalman, and R. L. Parrish**, 1991, Strength Analyses of the Weeks Island Bulkheads. Albuquerque, NM, Sandia National Laboratories Report SAND90-0013, 67 p.
- Carney, K. R., G. Hunt, E. B. Overton, W. J. Autin, and M. A. Molecke**, 1995, Near-surface gas mapping profiles of salt geologic features at the Weeks Island Strategic Petroleum Reserve site. Deerfield, IL, Solution Mining Research. Institute, San Antonio, TX, Fall Mtg., 12 p.
- Coates, G. K., C. A. Lee, W. C. McClain, and P. E. Senseny**, 1981, Failure of Man-Made Cavities in Salt and Surface Subsidence Due to Mining. Albuquerque, NM, Sandia National Laboratories Report SAND81-7145, 136 pp.
- Comptroller General of the United States**, 1978, Questionable Suitability of Certain Salt Caverns and Mines for the Strategic Petroleum Reserve, EMD-78-65, 14 August 1978.
- Diamond, W. and K. E. Mills**, 1994, Informal communication at a meeting of SPR participants and Morton Salt Company, July, 1994. The idea of injecting brine evidently was a collective, spontaneous decision arrived at by several individuals, most conspicuously Diamond and Mills.
- DOE**, 1995a, Strategic Petroleum Reserve Annual/Quarterly Report. Washington, D. C., U. S. Strategic Petroleum Reserve, Report DOE/EE-0055, 15 Feb 95.
- DOE**, 1995b, Groundwater Control and Inventory Relocation. New Orleans, LA, Project Management Office, Internal Memorandum dtd. 9 Mar 95, L. J. Rousseau to W. C. Gibson.
- DOE**, 1995c, Weeks Island Sequential Drawdown Comprehensive Contingency Plan. New Orleans, LA, Strategic Petroleum Reserve Project Management Office, 24 Oct 1995, 16 p..
- DOE**, 1995d, Environmental Assessment for Decommissioning the Strategic Petroleum Reserve Weeks Island Facility, Iberia Parish, Louisiana. DOE/EA-1051, November 30, 1995, with Attached Finding of No Significant Impact (FONSI), December 1, 1995.
- Ehgartner, B. L.**, 1993, Weeks Island stress prediction and relationship to sinkhole formation. Albuquerque, NM, Sandia National Laboratories Department 6113 internal memorandum, 18 Oct. 1993.
- Ehgartner, B. L.**, 1994, Dilatancy criterion for Weeks Island salt. Albuquerque, NM, Sandia National Laboratories Department 6113 internal memorandum, 21 Feb. 1994.

- Federal Energy Administration**, 1977, Supplement to Final Environmental Impact Statements for Weeks Island/Cote Blanche Mines. Strategic Petroleum Reserve Office, EPA/7677-7 and FES 76/77-8, FEAS-77/228.
- Gulf Interstate Engineering Company**, 1978, Weeks Island Mine Certificate of Usability and Integrity of the Strategic Petroleum Reserve Program for the Department of Energy.
- Harding, R. S. Jr.**, 1994, Borehole seismic survey, Weeks Island Sinkhole. Albuquerque, NM, Sandia National Laboratories Department 6114 internal memorandum with attachments, 13 p.
- Hoffman, E. L.**, 1994, Preliminary results of a three-dimensional structural evaluation of the SPR Weeks Island oil storage facility. Albuquerque, NM, Sandia National Laboratories Department 1517 internal memorandum, 10 Mar. 1994.
- Hoffman, E. L. and Ehgartner, B. L.**, 1994, Performance of the Weeks Island Mine after decommissioning. Albuquerque, NM, Sandia National Laboratories Department 6113 Internal Memorandum, 12 Dec 94.
- Jacobs Engineering**, 1988, Conceptual Design Report for Bulkhead Upgrades. Contract Report to U. S. DOE, New Orleans, LA.
- Knauth, L. P.**, 1987, Stable isotope constraints on the origin of brine in the Weeks Island Strategic Petroleum Reserve, Contract Report to PB-KBB, and Boeing Petroleum Services.
- Knauth, L. P.**, 1994, Stable isotope constraints on the origin of brine in the Weeks Island Strategic Petroleum Reserve. Arizona State University contract Report to DynMcDermott Petroleum Operations Company, New Orleans, LA.
- Kupfer, D. H.**, 1990, Anomalous Features in the Five Islands Salt Stocks. Transactions, Gulf Coast Association of Geological Societies, 40: 425-437.
- Linn, J. K. and T. E. Hinkebein**, 1994, Modeling estimates of dye detection in fill holes. Albuquerque, NM Sandia National Laboratories Department 6113 internal memorandum.
- LSU**, 1994, Contract report from Institute for Environmental Studies, Louisiana State University to Sandia National Laboratories, Albuquerque, NM, 29 July, and October 1994.
- Martinez, J. D., et al.**, 1978, An Investigation of the Utility of Gulf Coast Salt Domes for the Storage or Disposal of Radioactive Wastes. Baton Rouge, LA, Louisiana State University Institute for Environmental Studies, U. S. D. O. E. Report EW-78c, 05-5941/53, Vol. 1, p. 189-234.
- Martinez, J. D.**, 1979, Water Leaks in the Markel Bulkhead Drift in the Weeks Island Mine: Evaluation and Recommendations. Consultants Report to Parsons-Gilbane for the U. S. D. O. E., 16 p
- Martinez, J. D.**, 1995, Weeks Island Hydrology Prior to Oil Storage. Deerfield, IL, Solution Mining Research Institute Spring Meeting Archives, New Orleans, LA.
- Miller, R. D., I. Xia, R. S. Harding, J. T. Neal, J. W. Fairborn, and D. W. Steeples**, 1996, Seismic Investigation of a Surface Collapse Feature at Weeks Island Salt Dome, Louisiana. Cambridge, MA, Blackwell Science; Environmental Geosciences, Jan 1996.
- Molecke, M.A. and S.J. Bauer**, 1995a, Memo to J.K. Linn, Sandia National Laboratories, "Preliminary Results of the Weeks Island Risk Assessment Study, Executive Summary," April 10, 1995
- Molecke, M.A. and S.J. Bauer**, 1995b, Weeks Island Strategic Petroleum Reserve Site Drawdown: Geotechnical Risk Assessment Study. Albuquerque, NM, Sandia National Laboratories Report SAND95-1774, 78 p.
- Molecke, M.A. and S.J. Bauer**, 1995c, Albuquerque, NM, Sandia National Laboratories Department 6113 internal memorandum to J.K. Linn, "Results of the Weeks Island Environmental Assessment, Long-Term Risk Results," June 15, 1995.
- Molecke, M.A. and S.J. Bauer**, 1995d, Albuquerque, NM, Sandia National Laboratories Department 6113 internal memorandum to J.K. Linn, "Preliminary Results of the Weeks Island Hypothetical "No Action Alternative " and Flooded Markel Mine Environmental and Risk Assessments," July 20, 1995.
- Neal, J. T., T. R. Magorian, R. L. Thoms, W. J. Autin, and R. P. McCulloh**, 1993, Anomalous Zones in Gulf Coast Salt Domes with Special Reference to Big Hill, TX, and Weeks Island, LA. Albuquerque, NM, Sandia National Laboratories Report SAND92-2283, 65 p.

- Neal, J. T., 1995b, Additional Notes on Weeks Island Sinkhole #2. Albuquerque, NM, Sandia National Laboratories Department 6113 memorandum, J. T. Neal to R. E. Myers, US DOE, 15 March 1995.
- Neal, J. T., and R. E. Myers, 1995a, Origin, Diagnostics, and Mitigation of a Salt Dissolution Sinkhole at Weeks Island, Louisiana. 5th International Symposium on Land Subsidence. International Association of Scientific Hydrology Pub. 234, p. 187-195.
- Nieland, J. D., Chen, R., and J. L. Ratigan, 1994, Numerical Modeling of Weeks Island Subsidence. RE/SPEC Report RSI-0509 prepared for DynMcDermott Petroleum Operations Company, New Orleans, LA.
- Ostensen, R.W., 1994, Albuquerque, NM, Sandia National Laboratories Department 6113 Memo to Distribution, "Oil Outflow from Pressurization of Weeks Island Mine," June 6, 1994.
- Ostensen, R. W., 1995a, Albuquerque, NM, Sandia National Laboratories, Department 6113 Memo to Distribution, "Water Levels Around the Weeks Island Sinkhole," January 26, 1995.
- Ostensen, R.W., 1995b, Albuquerque, NM, Sandia National Laboratories Department 6113 Memo to Distribution, "Oil Leakage after a Hypothetical Washout into the Weeks Island Mine," February 21, 1995.
- Ostensen, R.W., 1995c, Albuquerque, NM, Sandia National Laboratories Department 6113 Memo to Distribution, "Considerations of Oil Siphoning from the Weeks Island Mine," March 24, 1995.
- Ortiz, T. S., 1980, Strategic Petroleum Reserve (SPR), Geological Summary Report, Weeks Island Salt Dome. Albuquerque, NM, Sandia National Laboratories Report SAND80-1323, 46 p.
- PB-KBB, 1994, Raw Water Injection Modeling of Conceptual Planning and Engineering Remedial Work at the Weeks Island Site, Task 11, prepared for the U. S. DOE under Contract DE-AC01FE62075, New Orleans, LA.
- PB-KBB, 1996, Plugging and Abandonment Plan for the Weeks Island Strategic Petroleum Reserve Facility. Report to U. S. DOE, Mine Integrity Management Group, New Orleans, LA.
- Russo, A.J., 1983, A User's Manual for the Salt Solution Mining Code SANSMIC. Albuquerque, NM, Sandia National Laboratory Report SAND83-1150.
- Russo, A. J., 1994, Albuquerque, NM, Sandia National Laboratories Department 1511 internal memorandum, "Preliminary Weeks Island Mine Inflow Calculations," 9 Mar 94.
- Russo, A.J., 1994b, Albuquerque, NM, Sandia National Laboratories Department 1555 Memo to J.K. Linn, "Opinions Regarding the Weeks Island Mine Inflow Calculations," March 9, 1994.
- Thoms, R. L., 1989, Brine in the Weeks Island SPR Facility. Contract 54-3944 Report to Sandia National Laboratories, Division 6257, Albuquerque, NM
- Todd, J. L., and J. E. Uhl, 1993, Albuquerque, NM, Sandia National Laboratories Department 6113 Letter Report, "Markel Mine Monitor; Interim Capability," 34 p.
- Thoms, R. L. and R. M. Gehle, 1995, Causal Factors of Sinkhole Formation. Deerfield, IL, Solution Mining Research Institute Spring Meeting, New Orleans, LA.
- VanSambeek, L. L., Osnes, J. D., and J. D. Nieland, 1994, Geomechanics Considerations for Flooding the Weeks Island Mine Strategic Petroleum Reserve Facility. RE/SPEC Report RSI-0541 prepared for DynMcDermott Petroleum Operations Company, New Orleans, LA.
- ViroGroup, 1994, Weeks Island SPR Site Aquifer Evaluation. Contract Report to Dillingham / Foundation. New Orleans, LA, DynMcDermott Petroleum Operations Company.
- Walk, Haydel and Associates, 1996, Weeks Island Oil Skimming System - Subsurface Facility. AFC Submittal under Contract No. DE-AC96-94PO19002 with U. S. DOE.
- Yeh, S., 1994, Albuquerque, NM, Sandia National Laboratories Department 6113 internal memorandum to J. K. Linn, "Analysis of Surface Subsidence and Evaluations at Bayou Choctaw, Bryan Mound, Weeks Island, and West Hackberry Strategic Petroleum Reserve Crude Oil Storage Sites."

Distribution:

U.S. DOE SPR PMO (15)
900 Commerce Road East
New Orleans, LA 70123
Attn: W. C. Gibson, FE-44 (2)
L. C. Barrow, FE-44.4
J. C. Kilroy, FE-443
J. Culbert, FE-4431
J. W. Kunkel, FE-4422
N. Shourbaji, FE-4421
R. E. Myers, FE-4422 (2)
J. Berndsen FE-433.1 (3)
D. Brine FE-4441
TDCS (2)

U.S. Department of Energy (8)
Strategic Petroleum Reserve
1000 Independence Avenue SW
Washington, D.C. 20585
Attn: R. D. Furiga, FE-40
D. Johnson, FE-421 (5)
D. Buck, FE-421
H. Giles, FE-423

DynMcDermott Petroleum Operations (6)
850 South Clearview Parkway
New Orleans, La 70123
Attn: G. Hughes, EF-22
K. Mills, EF-20
R. E. Gump, EF-25 (3)
J. Teerling, EF-83

Bayou Choctaw SPR Site
60825 Hwy. 1148
Plaquemine, LA 70764
Attn: J. C. Morris

Big Hill SPR Site
P. O. Box 1270
Winnie, TX 77665
Attn: Allen Fruge

Bryan Mound SPR Site
P.O. Box 2276
Freeport, TX 77541
Attn: C. Bellam

Weeks Island SPR Site (5)
P.O. Box 434
New Iberia, LA 70560
Attn: M. Jackson (3)
R. Phillips
M. Bertoldi

West Hackberry SPR Site
1450 Black Lake Road
Hackberry, LA 70645
Attn: R. Francouer

Joe L. Ratigan
RE/SPEC, Inc.
3824 Jet Drive
Rapid City, SD 57709

Rudy Begault
The MITRE Corporation
800 Commerce Road East, Suite 201
New Orleans, LA 70123

Richard Ginn
Underground Injection Control
Railroad Commission of Texas
Austin, TX 78711-2967

Ben Knape
Texas Natural Resource Conservation Commis-
sion
P. O. Box 13087, Capitol Station
Austin, TX 79811-3087

Bill Walter
Injection and Mining Division
Louisiana Office of Conservation
P.O. Box 94275, Capitol Station
Baton Rouge, LA 70804-9275

Acres International Corporation (2)
140 John James Audubon Parkway
Amherst, NY 14228-1180
Attn: S. Thompson

PB-KBB Inc. (2)
11767 Katy Freeway
P.O. Box 19672
Houston, TX 77224
Attn: S. Raghuraman

Texas Bureau of Economic Geology
University Station, Box X
Austin, TX 78713
Attn: W. L. Fisher

Morton International, Inc. (2)
P. O. Box 1496
New Iberia, LA 70562-1496
Attn: J. Martin

AKZO Salt, Inc.
P. O. Box 106
Avery Island, LA 70513
Attn: H. Anderson

Edward M. Simmons, President
Avery Island Inc.
P. O. Box 105
Avery Island, LA 70513

H. W. Diamond
Solution Mining Research Institute
1745 Chris Court
Deerfield, IL 60015-2079

Prof. Edward Overton
Institute for Environmental Studies
Louisiana State University
Baton Rouge, LA 70803

Louisiana Geological Survey
University Station; Box G
Baton Rouge, LA 70893

freezeWall, Incorporated
P. O. Box 316
Rockaway, NJ 07868
Attn: Bob Foster

Walk, Haydel & Associates (2)
600 Carondelet Street
New Orleans, LA 70130-3587
Attn: Bill Smith
K. W. Martinez

Dr. Thomas R. Magorian
133 South Drive
Amherst, NY 14226-4119

Dr. R. L. Thoms
AGM, Inc.
P.O. Box 10358
College Station, TX 77842

Joseph D. Martinez
3641 S. Lakeshore Drive
Baton Rouge, LA 70808

Sandia Internal:
6000 (MS 0724) J. B. Woodard
6100 (MS 0701) R. W. Lynch
6113 (MS 0706) J. K. Linn (10)
6113 (MS 0706) S. J. Bauer
6113 (MS 0706) B. Eghartner
6113 (MS 0706) T. Hinkebein
6113 (MS 0706) S. E. Lott
6113 (MS 0706) M. A. Molecke
6113 (MS0706) D. E. Munson
6113 (MS 0706) J. T. Neal (15)
6113 (MS 0706) R. W. Ostensen
6113 (MS 0706) A. R. Sattler
6114 (MS 0705) R. S. Harding, Jr.
6116 (MS 0750) S. Ballard
1517 (MS 0443) E. L. Hoffman
7613-2 (MS 0100) Document Processing
(for DOE/OSTI) (2)
8523-2 (MS 9018) Central Technical Files
4414 (MS 0899) Technical Library (5)
12615 (MS 0619) Print Media