

**HIGH TEMPERATURE PROPERTIES OF ALLOYS
BEING CONSIDERED FOR DESIGN OF A
CONCENTRIC CANISTER LAUNCHER**

R S. Rosen
Lawrence Livermore National Laboratory
Livermore, CA 94550 USA

R W. Lowry
Dahlgren Division
Naval Surface Warfare Center
Dahlgren, VA 22448 USA

and

M E Kassner
Department of Mechanical Engineering
Oregon State University
Corvallis, OR 97331 USA

June 1998

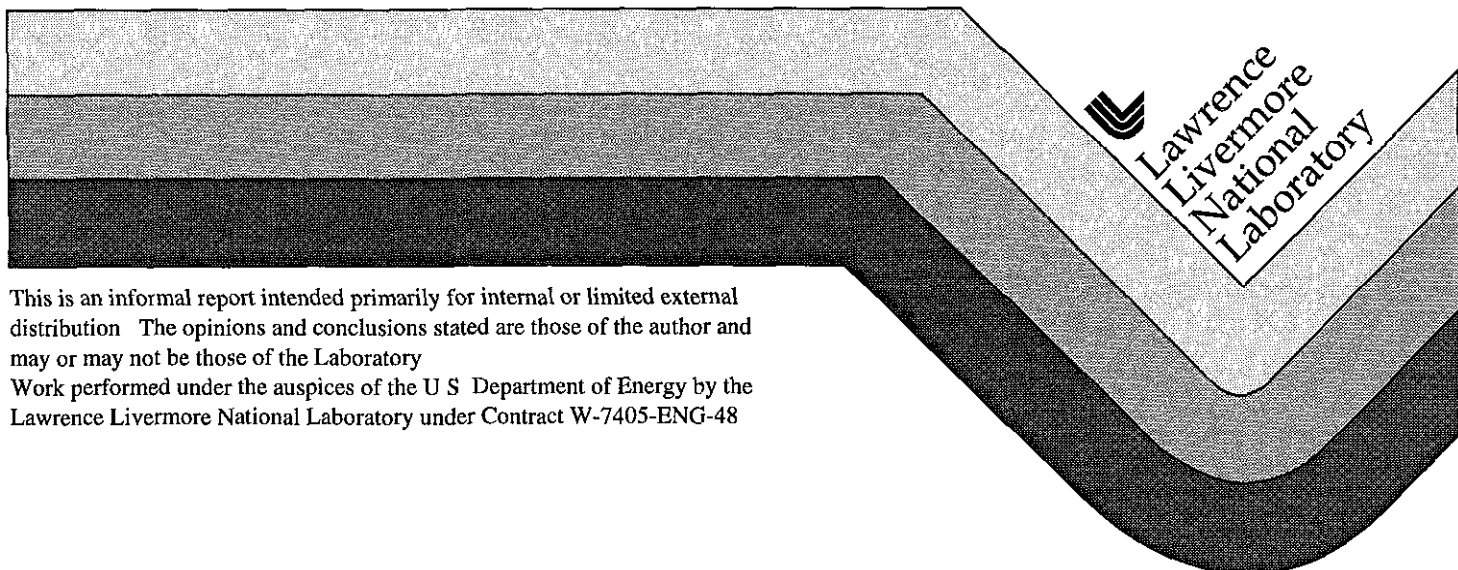

This is an informal report intended primarily for internal or limited external distribution. The opinions and conclusions stated are those of the author and may or may not be those of the Laboratory.
Work performed under the auspices of the U S Department of Energy by the Lawrence Livermore National Laboratory under Contract W-7405-ENG-48

DISCLAIMER

This document was prepared as an account of work sponsored by an agency of the United States Government. Neither the United States Government nor the University of California nor any of their employees, makes any warranty, express or implied, or assumes any legal liability or responsibility for the accuracy, completeness, or usefulness of any information, apparatus, product, or process disclosed, or represents that its use would not infringe privately owned rights. Reference herein to any specific commercial product, process, or service by trade name, trademark, manufacturer, or otherwise, does not necessarily constitute or imply its endorsement, recommendation, or favoring by the United States Government or the University of California. The views and opinions of authors expressed herein do not necessarily state or reflect those of the United States Government or the University of California, and shall not be used for advertising or product endorsement purposes.

This report has been reproduced
directly from the best available copy

Available to DOE and DOE contractors from the
Office of Scientific and Technical Information
P O Box 62, Oak Ridge, TN 37831
Prices available from (423) 576-8401

Available to the public from the
National Technical Information Service
U S Department of Commerce
5285 Port Royal Rd ,
Springfield, VA 22161

REPORT DOCUMENTATION PAGE

Form Approved
OMB No 0704-0188

Public reporting burden for this collection of information is estimated to average 1 hour per response, including the time for reviewing instructions, search existing data sources, gathering and maintaining the data needed, and completing and reviewing the collection of information. Send comments regarding this burden or any other aspect of this collection of information, including suggestions for reducing this burden, to Washington Headquarters Services, Directorate for Information Operations and Reports, 1215 Jefferson Davis Highway, Suite 1204, Arlington, VA 22202-4302 and to the Office of Management and Budget, Paperwork Reduction Project (0704-0188), Washington, DC 20503

1 AGENCY USE ONLY (Leave blank)		2. REPORT DATE June 1998	3. REPORT TYPE AND DATES COVERED Final	
4 TITLE AND SUBTITLE High Temperature Properties of Alloys Being Considered for Design of a Concentric Canister Launcher			5 FUNDING NUMBERS	
6 AUTHOR(s) Robert S Rosen, Robert W Lowry, Michael E Kassner				
7 PERFORMING ORGANIZATION NAME(S) AND ADDRESS(ES) Commander Naval Surface Warfare Center Dahlgren Division (Code G704) 17320 Dahlgren Road Dahlgren, VA 22448-5100			8 PERFORMING ORGANIZATION REPORT NUMBER NSWCDD/TR-98/72	
9. SPONSORING/MONITORING AGENCY NAME(S) AND ADDRESS(ES)			10. SPONSORING/MONITORING AGENCY REPORT NUMBER	
11 SUPPLEMENTARY NOTES				
12a. DISTRIBUTION/AVAILABILITY STATEMENT Approved for public release, distribution is unlimited			12b DISTRIBUTION CODE	
13 ABSTRACT (Maximum 200 words) This report describes a study to determine the high temperature mechanical properties of several titanium alloys and to compare them with properties of AISI 316L stainless steel and ASTM A387 structural steel. The steel materials are less costly to procure but exhibit good resistance to corrosion in seawater environments. Six titanium alloys were evaluated as candidate materials for use in a Concentric Canister Launcher (CCL). Each titanium alloy was tested at three temperatures (68°F, 2000°F, and 2400°F). Strain-rate change tests were used to determine the strain rate sensitivity of the alloys at each test temperature. Optical metallography was performed on two of the alloys to determine the relationship between test temperature and microstructure (presence of second phase precipitates, grain size). Complete test results are included, along with figures and tables of test data.				
14. SUBJECT TERMS Concentric Canister Launcher (CCL), titanium, tensile tests, strain rate sensitivity, optical metallography			15. NUMBER OF PAGES 33	
			16. PRICE CODE	
17 SECURITY CLASSIFICATION OF REPORTS UNCLASSIFIED	18 SECURITY CLASSIFICATION OF THIS PAGE UNCLASSIFIED	19 SECURITY CLASSIFICATION OF ABSTRACT UNCLASSIFIED	20 LIMITATION OF ABSTRACT UL	

FOREWORD

This report describes the results of a study undertaken to determine the high temperature mechanical properties of several alloys being considered for design of a concentric canister launcher (CCL). The work was carried out in support of Naval Surface Warfare Center, Dahlgren Division (NSWCDD) as part of one author's (Rosen's) Naval Reserve assignment as an Engineering Duty Officer with the Naval Sea Systems Command (SEA 03K) in Arlington, Virginia. R. S. Rosen is a member of Lawrence Livermore National Laboratory, Livermore, California. R. W. Lowry is the CCL project engineer for NSWCDD Code G72. M. E. Kassner is the Northwest Aluminum Professor of Mechanical Engineering and Director of the Graduate Program in Materials Science at Oregon State University, Corvallis, Oregon. The titanium alloy tensile tests were performed at Oregon State University and were funded by NSWCDD.

The authors wish to thank Steve Paddon and Troy Hayes of Oregon State University for their assistance in performing the titanium alloy tensile tests.

J. J. Yagla and G. C. Blount of the Combat Systems Safety and Engineering Division of the Weapons System Department have reviewed this report.

Approved by.

JOHNNY WALTERS, Deputy Head
Weapons Systems Department

CONTENTS

	<u>Page</u>
INTRODUCTION	1
EXPERIMENTAL PROCEDURE	2
RESULTS AND DISCUSSION	3
METALLOGRAPHY DATA	3
TENSILE TEST DATA	3
SUMMARY	5
REFERENCES	7
APPENDIX A-TITANIUM ALLOY TEST DATA	A-1
DISTRIBUTION	(1)

ILLUSTRATIONS

<u>Figure</u>		<u>Page</u>
1	CONCENTRIC CANISTER LAUNCHER	9
2	TITANIUM ALLOY TENSILE TEST SPECIMEN	10
3	INCREASE IN GRAIN SIZE OF Ti-15-3 WITH SOAK TIME AT 2000°F....	11
4a	VARIATION IN YIELD STRESS OF TITANIUM ALLOYS WITH TEMPERATURE	12
4b	YIELD STRESS OF TITANIUM ALLOYS AT VERY HIGH TEMPERATURES	13
5	VARIATION IN YIELD STRESS OF Ti-6-4 WITH STRAIN RATE...	14
6a	VARIATION IN STRAIN RATE SENSITIVITY OF Ti-6-4 WITH STRAIN RATE	15
6b	VARIATION IN STRAIN RATE SENSITIVITY OF Ti-6-4 WITH TEMPERATURE	16
7	VARIATION IN YIELD STRESS OF 316 STAINLESS STEEL WITH TEMPERATURE.	17
8	VARIATION IN YIELD STRESS OF TITANIUM ALLOYS, 316 STAINLESS STEEL, AND A387 STEEL WITH TEMPERATURE	18

TABLES

<u>Table</u>		<u>Page</u>
1	TITANIUM ALLOY DATA FROM THIS STUDY AND COMPILED FROM THE LITERATURE....	19
2	TYPE 316 STAINLESS STEEL AND A387 STEEL DATA COMPILED FROM THE LITERATURE	20

INTRODUCTION

The Office of Naval Research (ONR) has undertaken a program to develop a new Vertical Launching System (VLS) for future generation ships, such as the DD-21 Destroyer. The Naval Sea Systems Command Combat Weapons Program (NAVSEA 03K1) and Naval Surface Warfare Center Dahlgren Division (NSWCDD) are working jointly with industry and universities to develop one such launcher design, the Concentric Canister Launcher (CCL)

The CCL provides two significant advances over the current Mk 41 VLS. First, it is designed with a self-contained gas management system that eliminates the need to overhaul ship structures below deck level. Second, the CCL has its launch electronics distributed individually in each canister enhancing the reliability of the overall system. The launcher system would consist of an array of perhaps 32 CCLs, each carrying one missile, arranged in a modular rack which could be moved from ship to ship. The CCL design is adaptable to fire a variety of missiles in the Navy inventory. Remanufacturing and reloading of canisters after firings is one design alternative being considered.

The basic CCL design consists of a tube made of two concentric cylinders joined by sets of dual longerons; one end is open, the other is sealed with a hemispherical end cup, or "hemihead" (see Figure 1). During firing, the missile exhaust gas is turned 180 degrees by the hemihead and flows through the annular space between inner and outer cylinders. Ablative material would most likely need to be applied to the hemihead to protect the surface from erosion/corrosion at the extremely high temperatures produced by the exhaust gases during a "fly-out" of the missile. Depending on the missile utilized and the particular service environment (e.g., a restrained firing whereby the missile fails to exit the canister), maximum temperatures within the cylinder material have been calculated to exceed 2000°F (1093°C).

The extreme temperature combined with modest pressures from the hot gases in the annular region results in stresses of sufficient magnitude to consider a high temperature alloy for the CCL. Titanium is a material to be considered for this application because of its high specific strength and high temperature oxidation resistance combined with its outstanding resistance to corrosion in seawater. Therefore, the objective of this study is to determine the high temperature mechanical properties of several titanium alloys and to compare them with properties of AISI 316L stainless steel and ASTM A387 structural steel, materials less costly to procure than titanium but nonetheless exhibiting good resistance to corrosion in seawater environments.

EXPERIMENTAL PROCEDURE

The following titanium alloys were evaluated as candidate materials in this study (nominal compositions given): (1) TIMETAL 21S (Ti-15Mo-3Nb-3Al-2Si); (2) Ti-15-3 (Ti-15V-3Al-3Cr-3Sn); (3) Ti-13-11-3 (Ti-13V-11Cr-3Al), (4) Beta C (Ti-8V-3Al-6Cr-4Mo-4Zr); (5) Beta III (Ti-11.5Mo-6Zr-4.5Sn); and (6) Ti-6-4 (Ti-6Al-4V). The first five materials are beta stabilized at room temperature, exhibiting high strengths and good cold formability; Ti-6-4 is a two-phase alpha+beta structure at room temperature. Specimens to be tested were machined from sheet material supplied from the following sources: United Defense, Fridley, Minnesota (TIMETAL 21S), Titanium Metals Corporation (TIMET), Denver, Colorado (Ti-15-3), Crucible Materials, Pittsburgh, Pennsylvania, (Ti-13-11-3 and Beta III); RMI Titanium, Niles, Ohio (Beta C); and Metals Unlimited, Inc., Deer Park, New York (Ti-6-4).

The test specimen geometry consisted of a 2-inch-long tensile specimen having a rectangular cross-section with gage dimensions of 0.400 inches in length, 0.188 inches in width, and 0.600 inches in depth (see Figure 2). Machining tolerances of the finished specimen were ± 0.001 inches in all dimensions. Specimens were cut in the plane of the sheet material and surface finished on a milling machine. Afterwards, the specimens were encapsulated in a quartz chamber purged with argon prior to heat treatment. All of the specimen materials were solution treated and aged for maximum room temperature tensile strength properties as suggested by ASM data (Reference 1); an additional specimen of TIMETAL 21S was solution treated and aged to achieve maximum high temperature tensile strength as recommended by TIMET (Reference 2) (see Table A-1 in Appendix A). This process of quenching the "beta" alloys from the beta phase (815°C) and aging at approximately 540° to 480°C for 4 to 72 hours results in finely dispersed alpha precipitates in the beta structure.

Tensile tests were performed on a servohydraulic Instron model 8521 testing machine, capable of real-time computerized data acquisition. The specimens were held with a friction-type TZM molybdenum alloy (Mo-0.5Ti-0.1Zr-0.02W) grip and a tungsten pin. Instron universal joints were used on each side of the TZM grip to eliminate any bending moments applied to the specimen from the loading fixture.

Each of the titanium alloys was tested at three temperatures: 68°F (20°C), 2000°F (1093°C), and 2400°F (1316°C). The (elevated) test temperatures of the specimens were held to within $\pm 10^\circ\text{C}$ at the yield stress and ultimate tensile strength, and within $\pm 30^\circ\text{C}$ at the termination of the test (typically, after about 30 percent elongation). For tests performed at 1093°C and 1316°C, 3.0 to 3.5 minutes was required to heat the specimens to test temperature. Temperatures were measured on the specimen surface using Pt/Pt-13Rh type thermocouples. The temperature gradient from the surface to the center of the specimen was calculated to be less than 1°C. This small gradient is primarily due to the small size and flat shape of the specimen. Uniform temperatures (within 5°C) were measured across the gage length from shoulder to shoulder.

Strain-rate change tests were used to determine the strain rate sensitivity of the alloys at each test temperature. The strain rate sensitivity, $m = d[\log(\sigma)]/d[\log(d\epsilon/dt)]$, was determined at a constant structure (i.e., a particular microstructure) by measuring the change in the yield stress,

σ with an instantaneous change in the applied strain rate, $d\varepsilon/dt$. The changes in strain rate were $d\varepsilon/dt = 10^{-4} \text{ s}^{-1}$ to 10^{-2} s^{-1} at 20°C , and $d\varepsilon/dt = 10^{-3} \text{ s}^{-1}$ to 10^{-2} s^{-1} at 1093°C and 1316°C tests. High purity (Grade 5) argon was used to purge a quartz chamber surrounding the titanium specimens during the high temperature tests. This ensured that the test results would not be influenced by high temperature oxide embrittlement of the titanium alloys (Reference 3). Percent elongation and reduction in area were measured directly from the specimen at the conclusion of the tensile tests. Percent elongation was also measured from the crosshead displacement of the Instron machine to a resolution of 0.0001 inch. Stress-strain relationships were determined by subtracting the Instron machine system compliance from the load-elongation data as measured from the crosshead displacement. Yield stresses and ultimate tensile strengths were reported as engineering values (based on initial cross-sectional area). Yield stresses were measured at a strain (plastic) of $\varepsilon_p = 0.002$ using the 0.2 percent strain offset method. Tensile test data are given in Appendix A, Table A-1 (68°F), Table A-2 (2000°F), and Table A-3 (2400°F).

Optical metallography was performed on two of the titanium alloys (Ti-15-3, Ti-6-4) in order to determine the relationship between test temperature and microstructure (presence of second phase precipitates, grain size). Grain size for the Ti-15-3 alloy was measured by determining the number of grain boundaries that intersect a given length of random line after 1, 2, 5, and 10 minutes at 2000°F . The Ti-6-4 alloy specimens were examined after heat-treating and in the area of the grip (where little or no deformation occurred) after tensile tests at 2000°F and 2400°F were completed.

RESULTS AND DISCUSSION

METALLOGRAPHY DATA

The average grain size of the Ti-15-3 alloy after heat-treating measured about 0.05 mm/grain boundary. After soaking for 1 min at 2000°F , the average grain size had increased to about 0.13 mm/grain boundary (mm/gb), and the microstructure was completely solution treated (no alpha phase precipitates visible in the beta matrix). After a total of 5 minutes at 2000°F , grain growth had ceased and the average grain size had stabilized at about 0.24 mm/gb. Figure 3 shows a plot of this data. The grain size was found to increase rapidly over the first minute, then decrease in growth rate with subsequent heating time. The grain size of the as-heat treated Ti-6-4 alloy was extremely small, on the order of 0.001 mm/gb at room temperature. After testing at 2000°F , the average grain size had increased to about 0.26 mm/gb. After testing at 2400°F , the average grain size had increased to about 0.32 mm/gb.

TENSILE TEST DATA

Table 1 lists the titanium alloy tensile test data from tests performed in this study (68°F , 2000°F , and 2400°F) and from data compiled from the literature at various strain rates and temperatures (References 4-11). Figure 4 shows the variation in yield stress of the candidate titanium alloys with temperature at a strain rate of $d\varepsilon/dt = 10^{-3} \text{ s}^{-1}$. It can be seen in Figure 4a

that, for all six alloys, the yield stress decreases approximately linearly with increasing temperature up to 1000°F, at this temperature, the values are about one-half those of room temperature. Above 1400°F, the yield stresses decrease to less than 10 percent of their room temperature values (data was not available in the temperature range between 1000° to 1400°F). At temperatures from ambient to 1000°F, TIMETAL 21S exhibits the highest yield stress (210 ksi or 1450 MPa) of the alloys tested. As expected, Ti-6-4 generally exhibits a lower yield stress (150 ksi or 1035 MPa) at all test temperatures than that of the beta alloys. At 2000°F, the yield stresses are less than 2 ksi (13.8 MPa); at 2400°F, they are less than 600 psi (4 MPa). At these very high temperatures, kinetic effects are presumably rapid enough to completely anneal the microstructure through short-range diffusion. The ability of the titanium alloys to resist plastic deformation is most likely determined by solid-solution hardening of the structure.

Figure 5 shows the effect (plotted on a log-log scale) strain rate has on yield stress for Ti-6-4 alloy compiled from data tested over a range of 5 orders of magnitude variation in strain rate. Increasing strain rate results in increasing yield (or flow) stress. This behavior is consistent within the temperature range shown (approximately 1400° to 2400°F). The rate of increase in yield stress is shown to decrease with increasing strain rate. Strain-rate sensitivity, $m = d[\log(\sigma)]/d[\log(d\epsilon/dt)]$, $0 < m \leq 1$, is a measure of this rate of increase and indicates the ability of a material to resist plastic instability or necking during tensile loading. When m is low, an increase in stress at the neck leads to a large increase in strain rate at that location and consequently a low elongation to fracture. When m is large, the strain rate increases slowly in response to increased stress in the neck region and the neck forms gradually leading to a high elongation to fracture.

Strain rate sensitivity is known to change with strain, strain rate, temperature, and microstructure. Figures 6a and 6b show the effects (plotted on a semi-log scale) of strain rate and temperature, respectively, on strain rate sensitivity of Ti-6-4 alloy (at an approximately constant structure as determined at a constant plastic strain of 0.2 percent). Strain rate sensitivity is shown to increase with temperature and/or decreasing strain rate. Hence, Ti-6-4 approaches superplastic behavior ($m = 1$) at high temperatures and low strain rates. These results are consistent with published data showing the effect of grain size on flow stress and strain rate sensitivity, m as functions of strain rate for Ti-6-4 at 1700°F (Reference 12). Strain rate sensitivity, which is shown to decrease with increasing grain size for a given strain rate, increases with decreasing strain rates from 10^{-2} s^{-1} to about 10^{-4} s^{-1} . For a grain size of 0.02 mm, m is reported to increase from 0.3 at a strain rate of 10^{-2} s^{-1} to about 0.7 at $d\epsilon/dt = 10^{-5} \text{ s}^{-1}$ (Reference 12). Figure 6a shows that for Ti-6-4 data compiled from published test results at 1733 F, m increases from about 0.15 at a strain rate of 10^{-1} s^{-1} to about 0.8 at $d\epsilon/dt = 10^{-4} \text{ s}^{-1}$. These values would be consistent with Ti-6-4 grain sizes exceeding 0.02 mm, which is likely to be the case for specimens equilibrated at 1733 F based on the metallography results of tests at 2000°F from this study.

Mechanical properties of 316L (< 0.02% C) and 316 (~ 0.08% C) stainless steels are essentially the same; neither alloy contains enough carbon to form the martensite needed to increase strength through a quench and temper process. Therefore, tensile yield stress values from the literature were compiled using both 316L and 316 stainless steel data (References 13-16) (see Table 2). Data for ASTM A387 steel, a 2-1/4Cr-1Mo structural steel also exhibiting relatively good resistance to seawater corrosion, was compiled for comparison with 316 stainless steel (Reference 17).

Figure 7 shows the variation in yield stress of 316 stainless steels (316 and 316L combined) with temperature. The yield stress of annealed 316 stainless steel decreases with increasing temperature. Unlike that of titanium alloys, at 1400°F, the yield stress of 316 stainless steels (annealed or cold worked) is only reduced to about one-half that of its room temperature value. The microstructure of 316 stainless steel is essentially a single phase (austenite with perhaps some retained ferrite) from room temperature up to its melting point and, therefore, solid-solution hardening most likely accounts for the observed resistance to plastic deformation at very high temperatures. Prior cold work increases the yield stress of 316 stainless steel substantially up to temperatures of about 1800°F; above this temperature, the structure is presumably completely annealed and differences in yield stresses are indistinguishable. The ability of 316 stainless steel to strain harden at high temperatures (up to about 1800°F) is an important consideration for engineering design. It provides an added margin of safety for the CCL by allowing redistribution of stresses within the cylinder material thereby reducing the potential for catastrophic failure during a restrained firing scenario.

Figure 8 shows a combined plot of yield stress versus temperature for the titanium alloys, 316 stainless steel, and A387 steel. At temperatures up to 1000°F, all of the titanium alloys exhibit substantially higher yield stresses than those of the steels. At temperatures somewhere between 1000°F and 1500°F, the microstructural features that contribute to strain hardening (alpha phase precipitates dispersed in the beta alloys) have dissolved into solution and the yield stresses are no greater than (and perhaps not as high as) those of the 316 stainless steel. The yield stresses of annealed and cold worked A387 structural steel are roughly comparable to those of 316 stainless steel up to 1200°F (highest temperature where data was available for the A387 steel). However, the A387 steel appears to lose its increased strength from prior cold work at a lower temperature than that of the stainless steel.

SUMMARY

Room temperature tensile strengths of the titanium alloys evaluated in this study are all very high. TIMETAL 21S exhibited the highest yield stress, about 210 ksi (30 MPa), while the other beta alloys were found to yield at stresses of about 140 to 180 ksi (20 to 26 MPa). The Ti-6-4 alloy exhibited a yield stress of about 150 ksi (22 MPa).

Yield stresses of all the titanium alloys at temperatures above 2000°F were determined to be less than 1 percent of their room temperature values. Strain hardening does not occur in any of the alloys tested at these high temperatures. Yield stresses were found to increase substantially with increasing strain rate at elevated temperatures due to the high strain rate sensitivity of titanium at high temperatures. This contrasts with room temperature properties, where the titanium alloys are relatively insensitive to strain rate due to their low measured strain rate sensitivity. Additionally, strain rate sensitivities were found to increase substantially with increasing temperature and/or decreasing strain rate.

Titanium alloys exhibit yield stresses that are 2 to 4 times higher than that of 316L stainless steel at temperatures up to about 1000°F; above 1500°F, the yield stress of 316L stainless steel is comparable to those of the titanium alloys. The 316 stainless steel is able to strain harden (increase its flow stress with increasing strain) at temperatures up to about 1800°F. This provides an added margin of safety that may be an important consideration for engineering design of the CCL. The yield stress of A387 structural steel was found to be roughly equal to that of 316 stainless steel up to about 1200°F. Mechanical properties from this study can be used to model an optimum design of the CCL for both the fly-out and restrained firing conditions.

ACKNOWLEDGMENTS

This work was also performed under the auspices of the U.S. Department of Energy by Lawrence Livermore National Laboratory under contract No. W-7405-Eng-48.

REFERENCES

1. *Materials Property Handbook. Titanium Alloys*, R Boyer, G. Welsch, and E. W Collings, Editors, ASM International, 1994.
2. Data Sheet for TIMETAL 21S, Titanium Metals Corporation (TIMET), Denver, Colorado
3. Rosenberger, A H , "Effect of Vacuum Level on the Embrittlement of TIMETAL 21S," *Scripta Materialia*, 34, 1996, pp. 1877-1882.
4. O'Connell, T , "TIMETAL 21S," *Materials Property Handbook. Titanium Alloys*, R. Boyer, G. Welsch, and E W Collings, Editors, ASM International, 1994, pp 921-929
5. Hamilton, C. H , *Superplasticity in Titanium Alloys*, ASM International, 1985, pp. 13-22
6. *Beta Titanium Alloys in the 1980's*, R. R. Boyer and H. W. Rosenberg, Editors, TMS/AIME, 1984.
7. Morgan, G C. and Hammond, C., "Superplastic Deformation Properties of B-Ti Alloys," *Mater Sci Eng* , 86, 1987, pp 159-177
8. *Metals Handbook, Properties and Selection. Stainless Steels, Tool Materials, and Special-Purpose Materials*, Vol 3, 9th Edition, American Society for Metals, 1980.
9. McLellan, D L and Eichenberger, T. W , "Constitutive Equation Development (COED)," Vol 1, Technical Summary, SAMSO-TR-68-320, July 1968, p 80
10. Malcor, J. G., "Mechanical and Microstructural Behavior of Ti-6Al-4V Alloy in the Hot Working Range," *Titanium, Science and Technology*, G Lutjering, U. Zwicker, and W Bunk, Editors, Deutsche Gesellschaft fur Metallkunde, Germany, 1985, pp. 1495-1502.
11. "Hot Workability of Titanium Alloys," *Present Aspects of Titanium Materials Research in Japan*, The Iron and Steel Institute of Japan (Nippon Tekko Kyokai), Tokyo, Japan, 1986, pp 30-34 (in Japanese)
12. Paton, N. E , *Titanium, Science and Technology*, G. Lutjering, U Zwicker, and W Bunk, Editors, Deutsche Gesellschaft fur Metallkunde, Germany, 1985

REFERENCES (Continued)

13. Gibbs, T. W. and Wyatt, H. W. , "Short Time Properties of Type 316 Stainless Steel at Very High Temperatures," *Transactions of the ASME Journal of Basic Engineering*, Paper No 60-WA-11, 1960.
14. Gibbs, T. W. , Kyros, W. ; and Theberge, C. L. , "Development of a Resistance Heating Facility for the Determination of Tensile Properties of Aircraft and Missile Alloys," Avco Corporation, RaD , TM-63-8, Feb 1963.
15. Albertini, C. and Montagnani, M., *Nuclear Engineering and Design*, 57, 1980, pp. 107-123; C. Albertini and M. Montagnani, *International Conference on Mechanical Behaviour and Nuclear Applications of Stainless Steels at Elevated Temperatures*, Varese, London, Metals Society, 1982.
16. *Proceedings of Conference on Stainless Steels '84*, Chalmers University of Technology and Jernkontoret (Sweden) and the Metals Society (UK), Chalmers University of Technology, September 3-4, 1984, Goteborg, the Institute of Metals, London, 1985, p 393
17. Kawada, T. , *Data Sheets on the Elevated Temperature Properties of Normalized and Tempered 2 25-Cr-1Mo Steel for Pressure Vessels (ASTM A387-D)*, Report 74, National Research Institute for Metals, Tokyo.

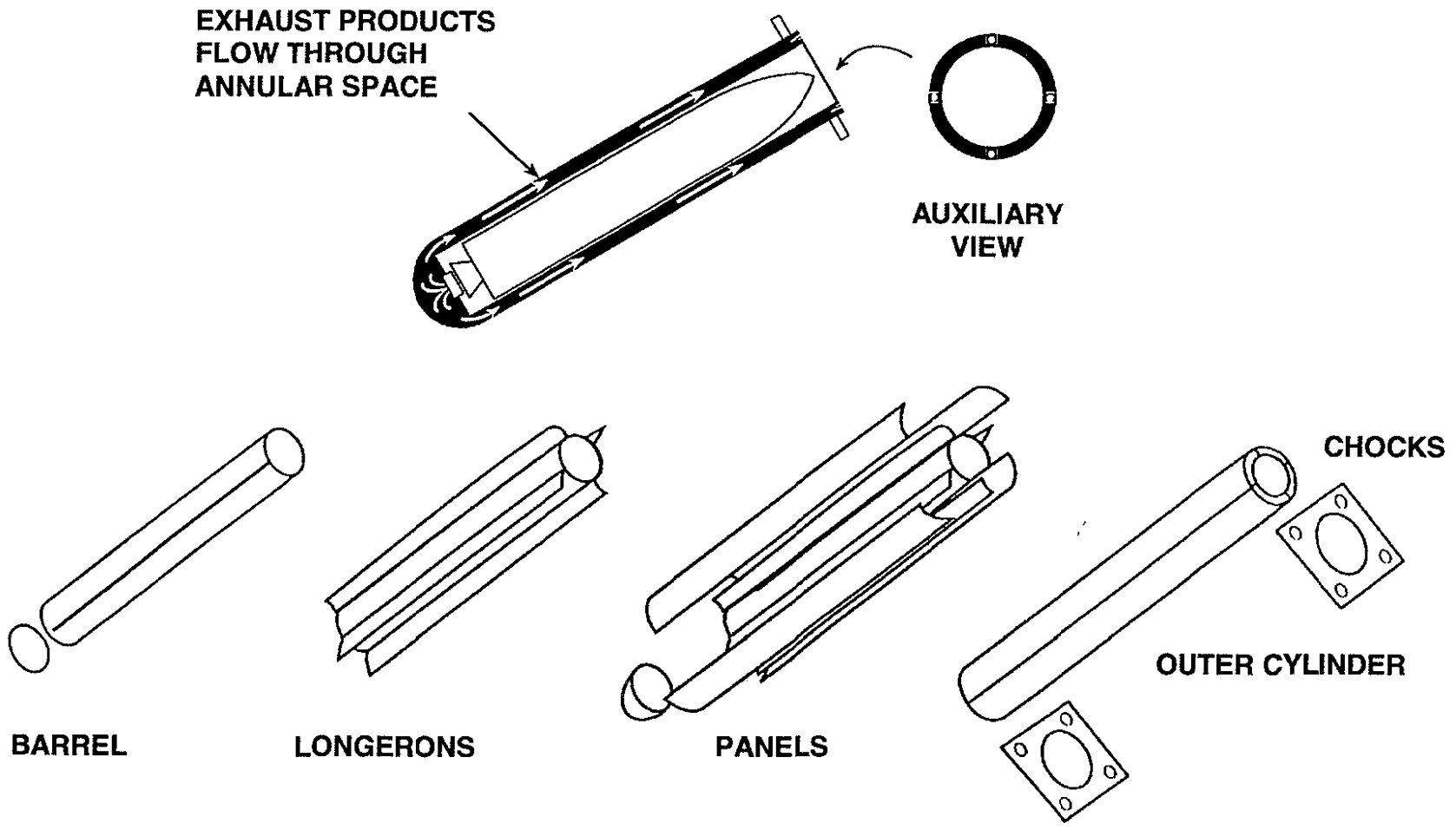

FIGURE 1. CONCENTRIC CANISTER LAUNCHER

All dimensions in inches

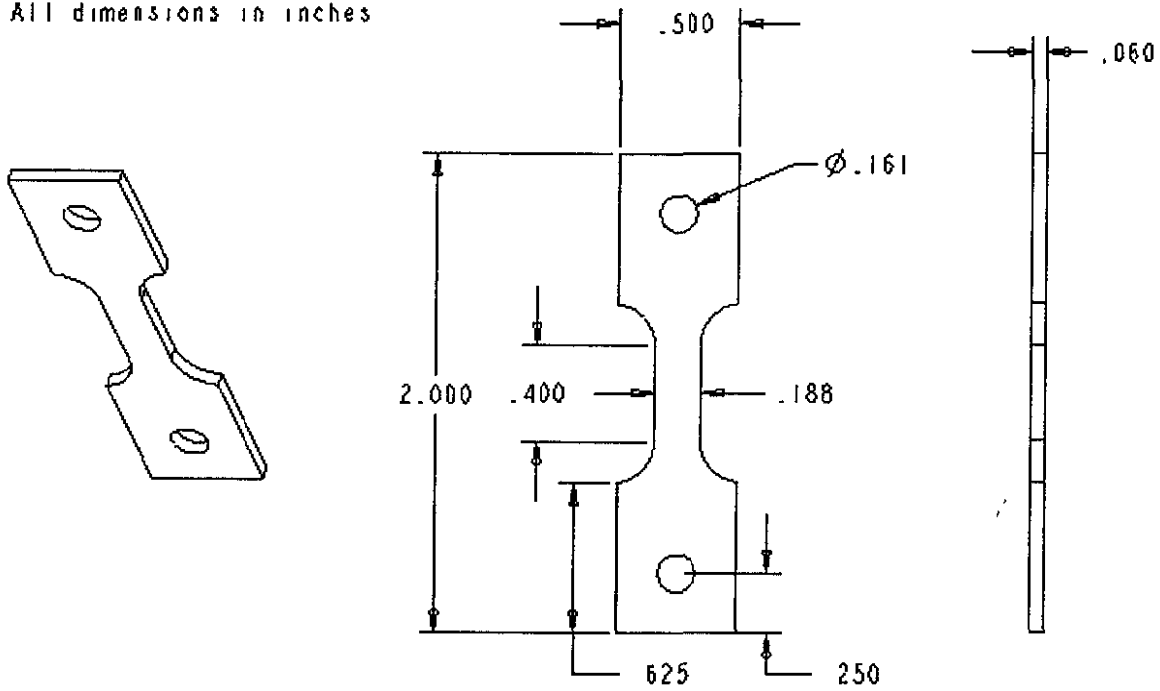

FIGURE 2. TITANIUM ALLOY TENSILE TEST SPECIMEN

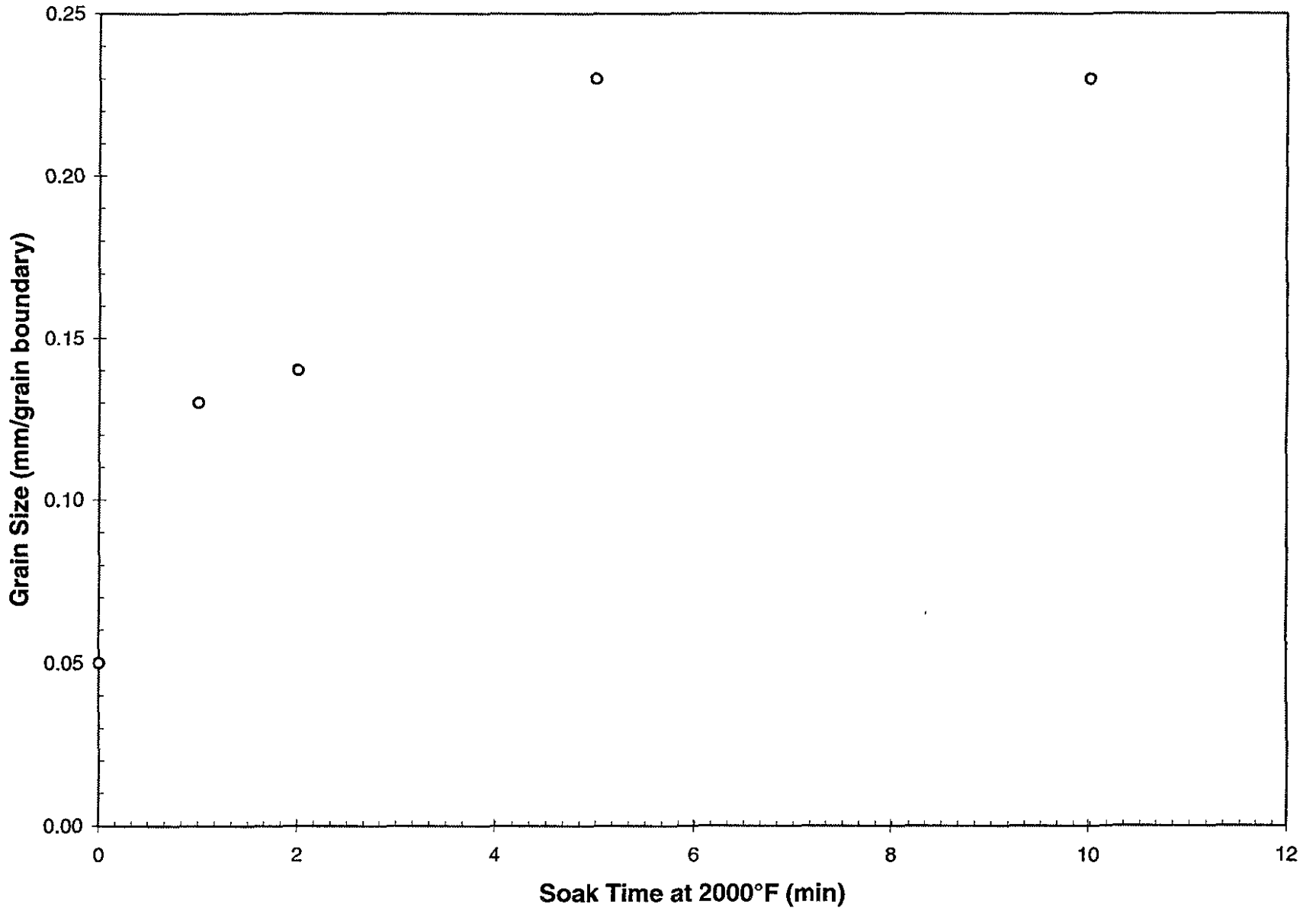

FIGURE 3. INCREASE IN GRAIN SIZE OF Ti-15-3 WITH SOAK TIME AT 2000°F

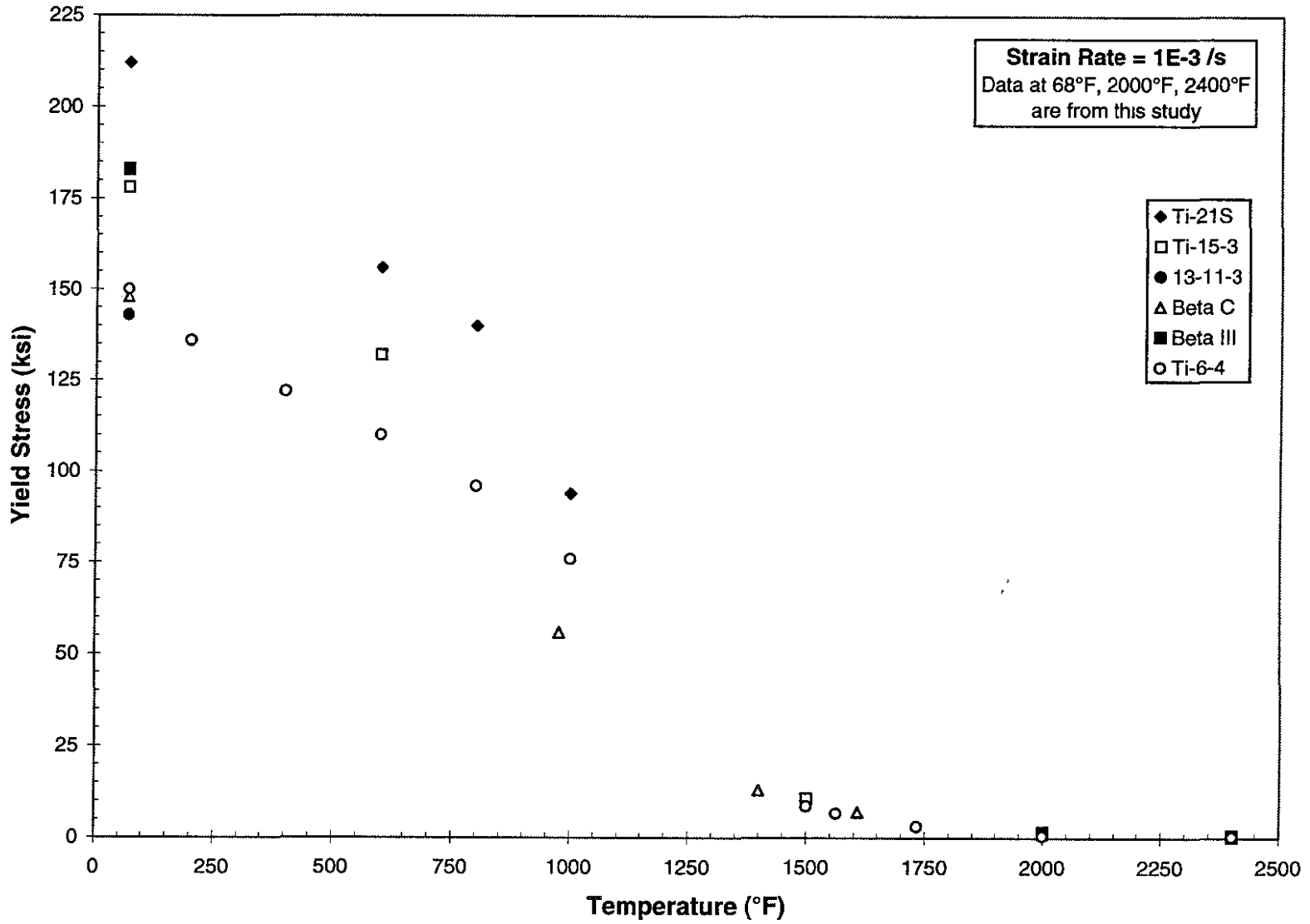

FIGURE 4a. VARIATION IN YIELD STRESS OF TITANIUM ALLOYS WITH TEMPERATURE

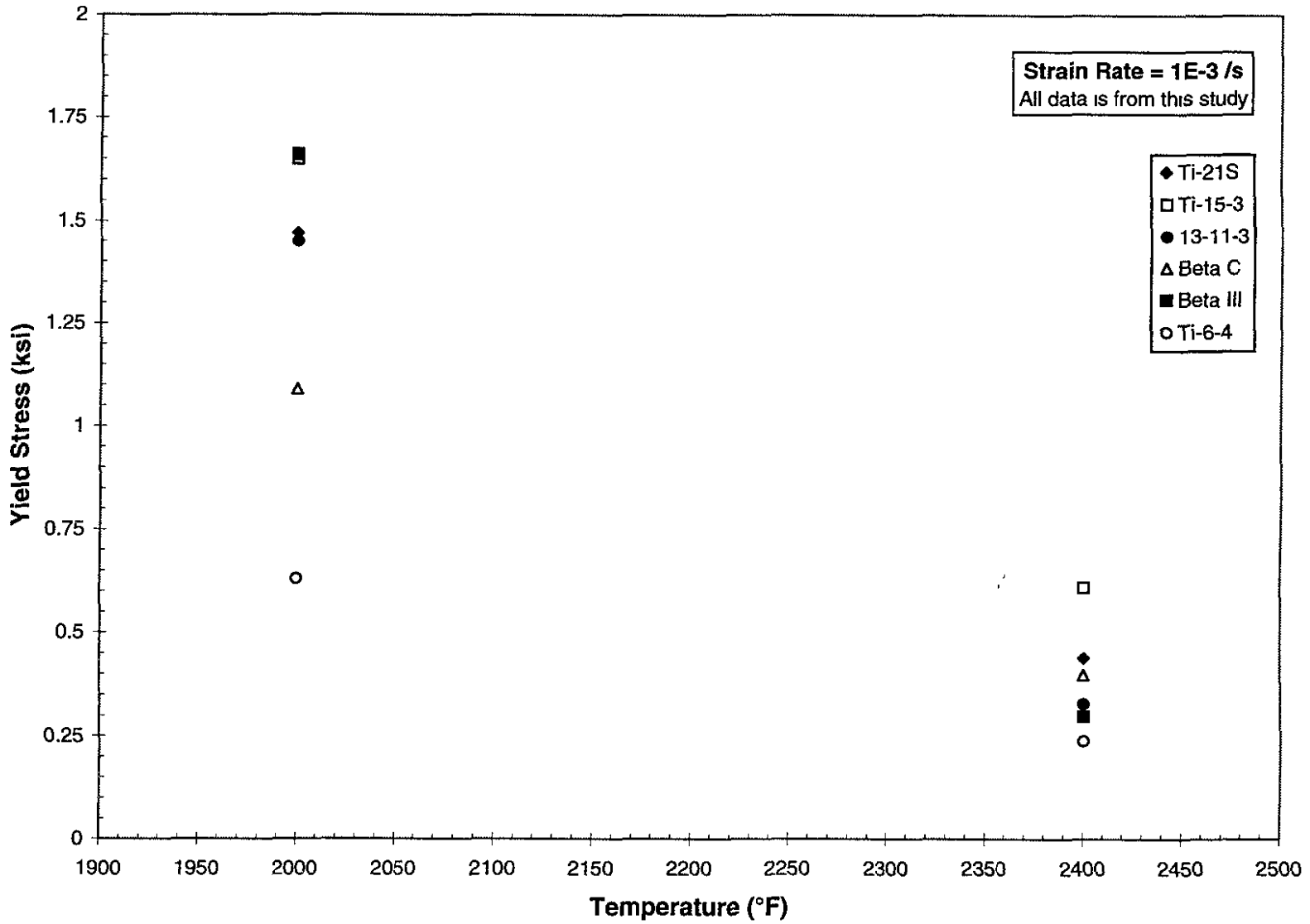

FIGURE 4b. YIELD STRESS OF TITANIUM ALLOYS AT VERY HIGH TEMPERATURES

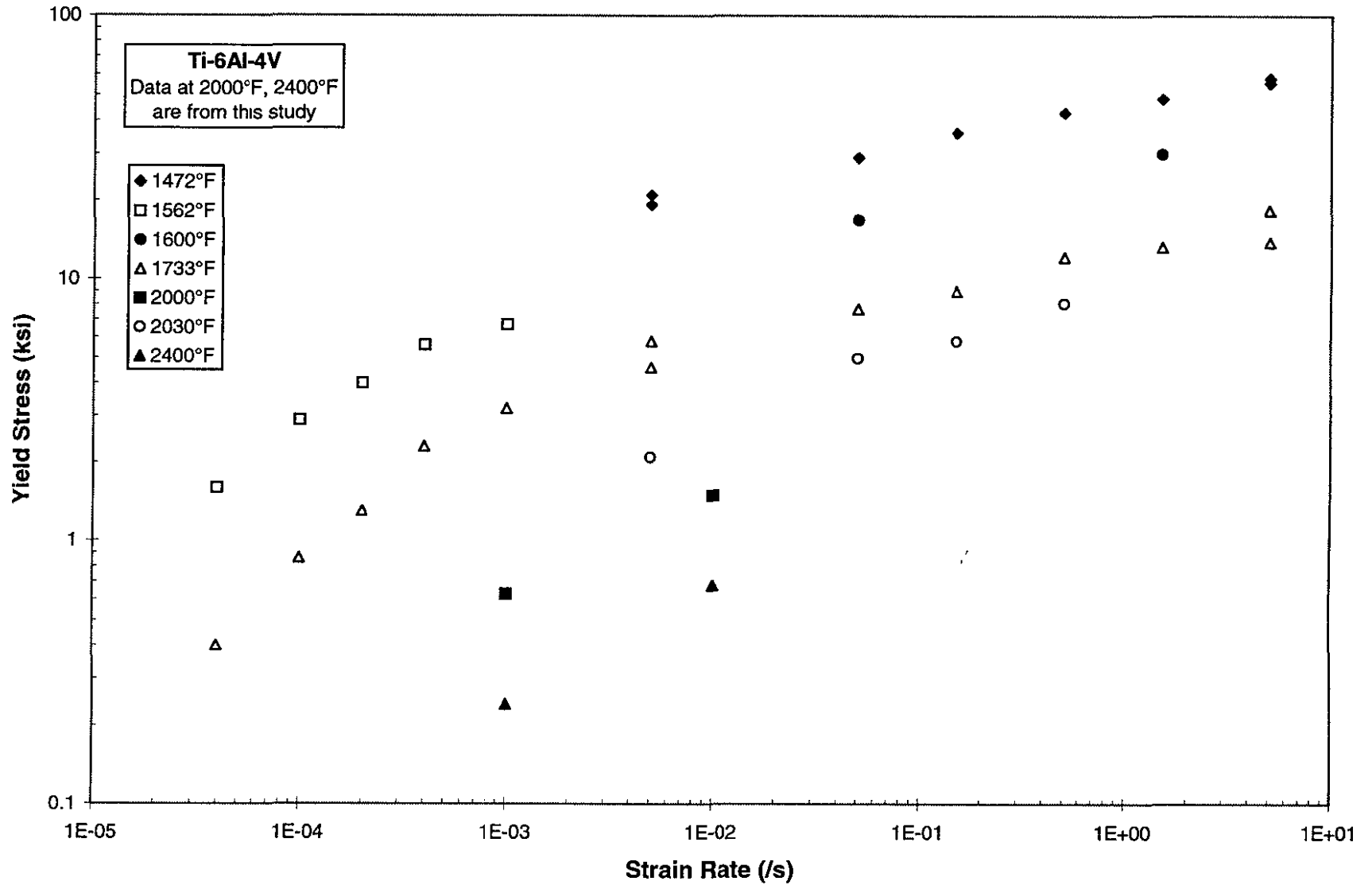

FIGURE 5. VARIATION IN YIELD STRESS OF Ti-6-4 WITH STRAIN RATE

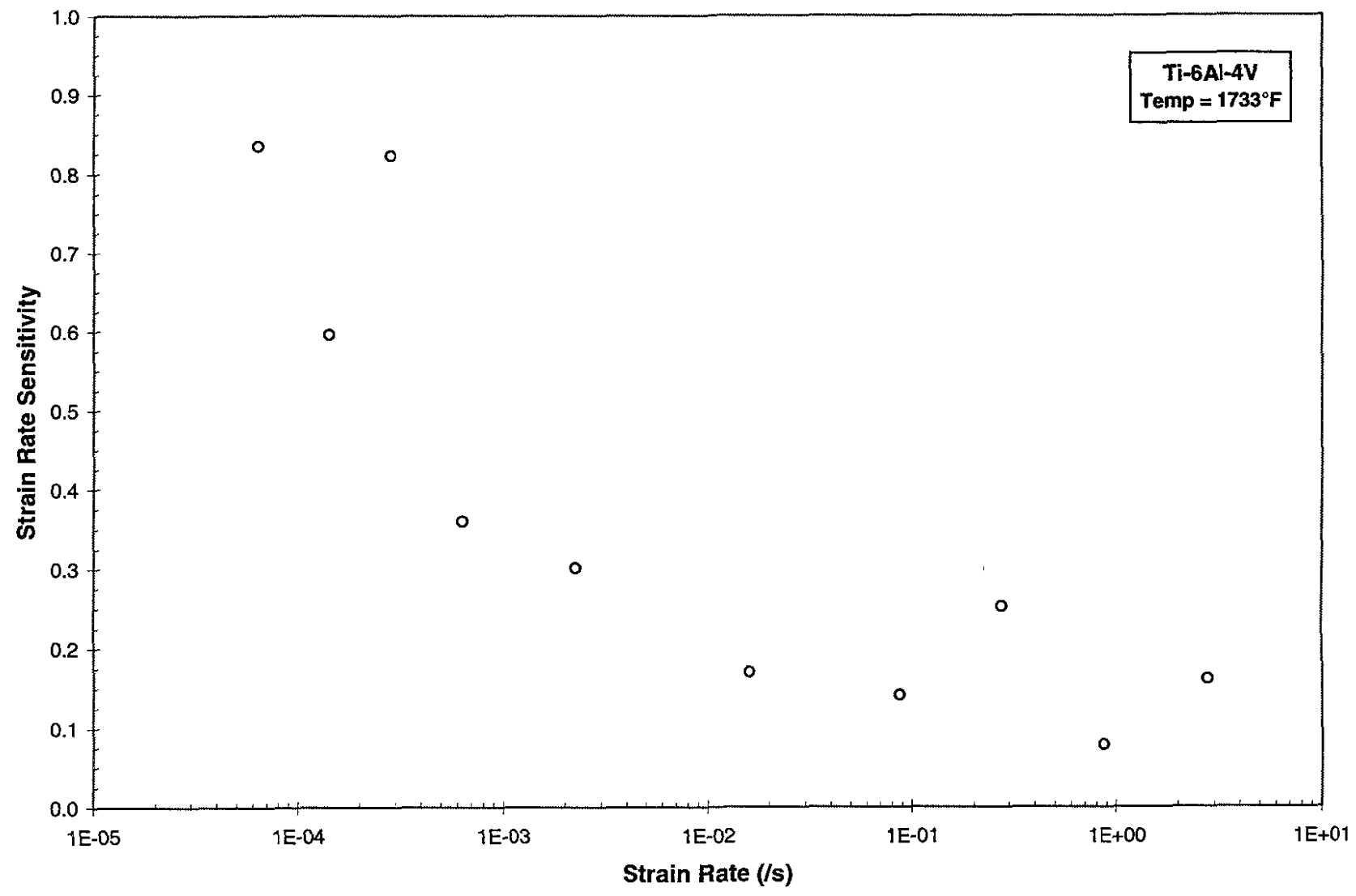

FIGURE 6a. VARIATION IN STRAIN RATE SENSITIVITY OF Ti-6-4 WITH STRAIN RATE

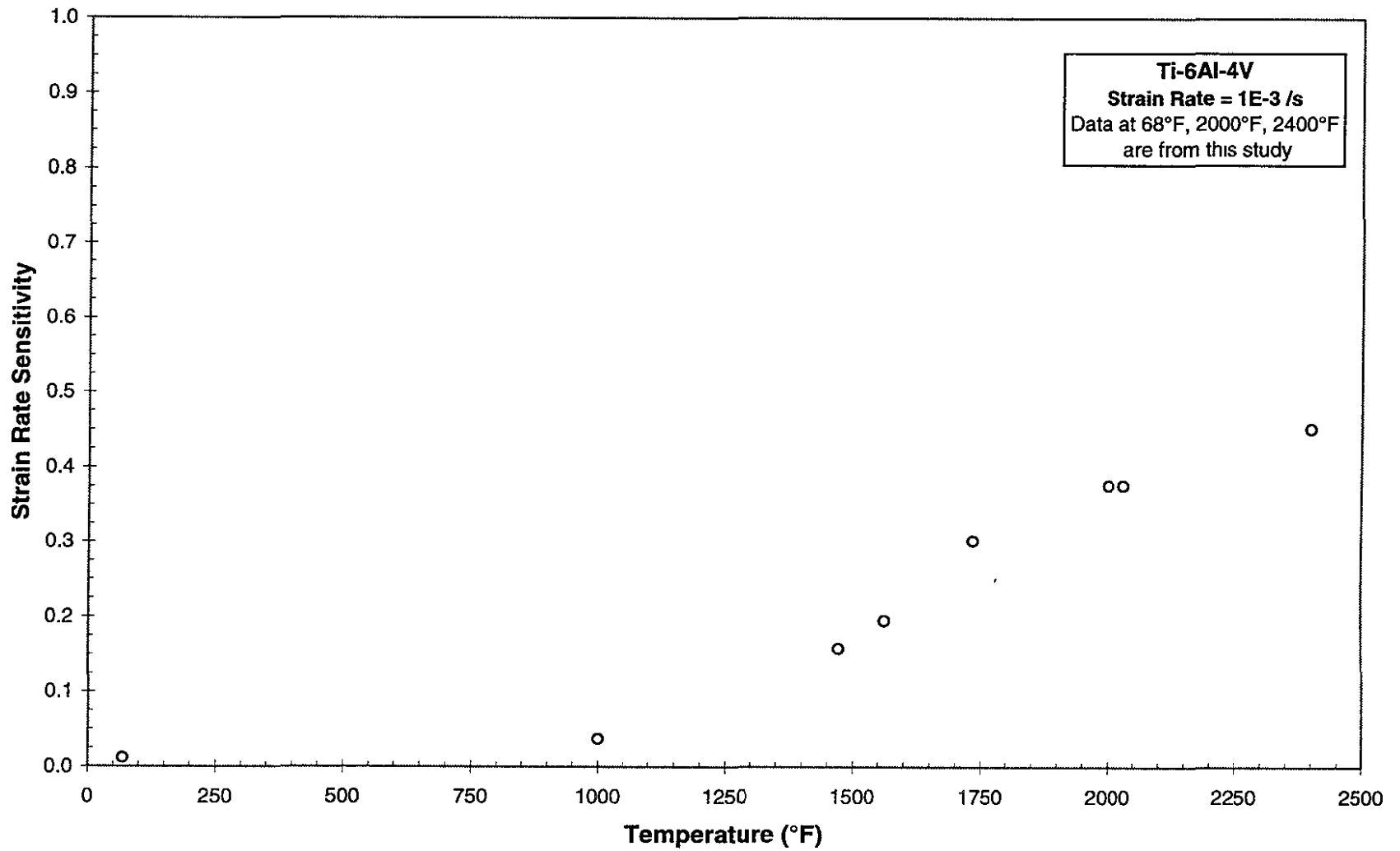

FIGURE 6b. VARIATION IN STRAIN RATE SENSITIVITY OF Ti-6-4 WITH TEMPERATURE

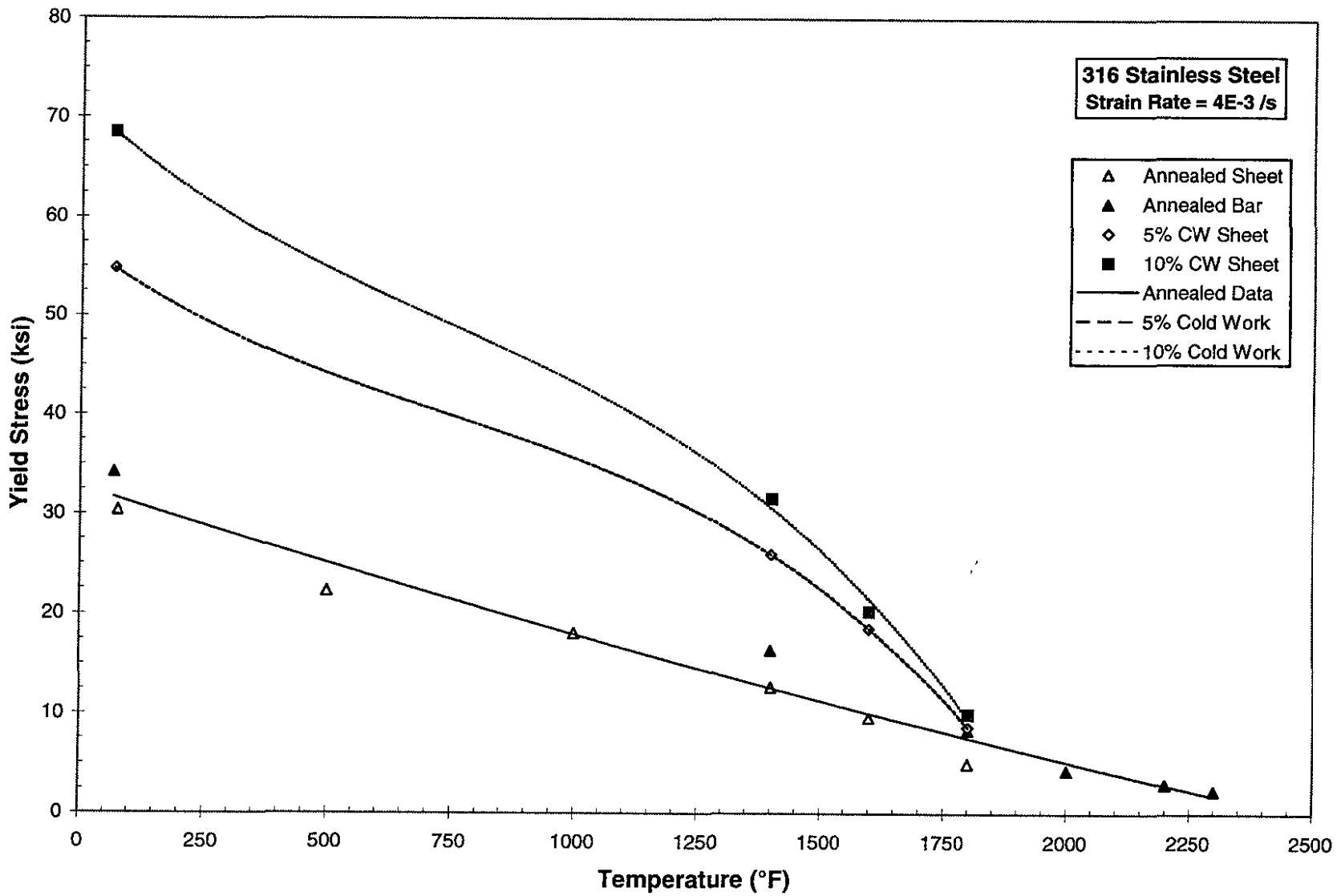

FIGURE 7 VARIATION IN YIELD STRESS OF 316 STAINLESS STEEL WITH TEMPERATURE

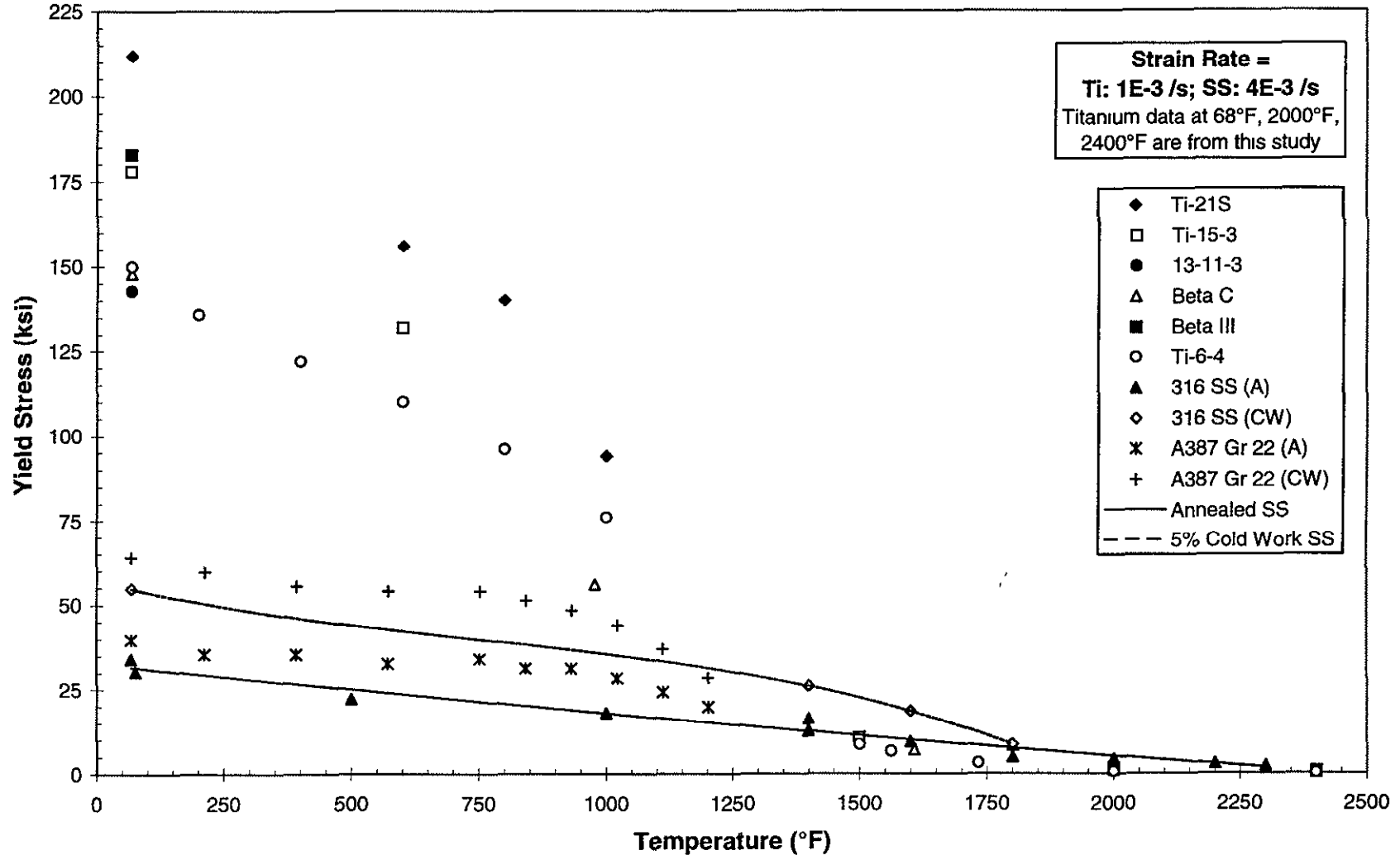

FIGURE 8. VARIATION IN YIELD STRESS OF TITANIUM ALLOYS, 316 STAINLESS STEEL, AND A387 STEEL WITH TEMPERATURE

TABLE 1. TITANIUM ALLOY DATA FROM THIS STUDY AND COMPILED FROM THE LITERATURE

Yield or Flow Stress of Various Titanium Alloys at a Strain Rate of 1E-3 /s															Strain Rate					
															Sensitivity of Ti-6-4					
Ti-21S	Ti-21S		Ti-15-3	Ti-15-3		13-11-3	13-11-3		Beta C	Beta C		Beta III	Beta III		Ti-6-4	Ti-6-4		Ti-6-4	Ti-6-4	
Temp (°F)	YS (ksi)	Ref	Temp (°F)	YS (ksi)	Ref	Temp (°F)	YS (ksi)	Ref	Temp (°F)	YS (ksi)	Ref	Temp (°F)	YS (ksi)	Ref	Temp (°F)	YS (ksi)	Ref	Temp (°F)	m (1E-3)	Ref
68	212		68	178		68	143		68	148		68	183		68	150		68	0.011	
600	156 [4]		600	132 [5]		2000	1.45		977	56 [6]		2000	1.66		200	136 [8]		1000	0.037 [9]	
800	140 [4]		1500	10.7 [5]		2400	0.33		1400	13 [7]		2400	0.3		400	122 [8]		1472	0.16 [10]	
1000	94 [4]		2000	1.65					1607	7.1 [7]					600	110 [8]		1562	0.20 [5]	
2000	1.47		2400	0.61					2000	1.09					800	96 [8]		1733	0.30 [5]	
2400	0.44								2400	0.4					1000	76 [8]		2000	0.38	
															1500	8.7 [5]		2030	0.38 [10]	
															1562	6.7 [5]		2400	0.45	
															1733	3.2 [5]				
															2000	0.63				
															2400	0.24				
Yield or Flow Stress of Ti-6Al-4V at Various Strain Rates and Temperatures															Strain Rate					
															Sensitivity of Ti-6-4					
1472°F	1472°F		1733°F	1733°F		2030°F	2030°F		2000°F	2000°F		2400°F	2400°F		1562°F	1562°F		Avg Strain		m
Rate (/s)	YS (ksi)	Ref	Rate (/s)	YS (ksi)	Ref	Rate (/s)	YS (ksi)	Ref	Rate (/s)	YS (ksi)	Ref	Rate (/s)	YS (ksi)	Ref	Rate (/s)	YS (ksi)	Ref	Rate (/s)	(1733°F)	Ref
			4.00E-05	0.4 [5]											4.00E-05	1.6 [5]				
			1.00E-04	0.86 [5]											1.00E-04	2.9 [5]		6.32E-05	0.84 [5]	
			2.00E-04	1.3 [5]											2.00E-04	4 [5]		1.41E-04	0.60 [5]	
			4.00E-04	2.3 [5]											4.00E-04	5.6 [5]		2.83E-04	0.82 [5]	
			1.00E-03	3.2 [5]											1.00E-03	6.7 [5]		6.32E-04	0.36 [5]	
5.00E-03	19.3 [11]		5.00E-03	5.8 [11]														2.24E-03	0.30 [5]	
5.00E-03	21 [10]		5.00E-03	4.6 [10]		5.00E-03	2.1 [10]		1.00E-03	0.63		1.00E-03	0.24							
5.00E-02	29 [10]		5.00E-02	7.7 [10]		5.00E-02	5 [10]		1.00E-02	1.5		1.00E-02	0.68		1600°F	1600°F		1.58E-02	0.17 [10]	
0.15	36 [10]		0.15	9 [10]		0.15	5.8 [10]								Rate (/s)	YS (ksi)	Ref	8.66E-02	0.14 [10]	
0.5	43 [10]		0.5	12.2 [10]		0.5	8.1 [10]								5.00E-02	16.9 [10]		2.74E-01	0.25 [10]	
1.5	48.5 [10]		1.5	13.3 [10]		1.5	9.3 [10]								1.5	30 [10]		8.66E-01	0.08 [10]	
5	58 [10]		5	18.4 [10]		5	11.6 [10]											2.74E+00	0.16 [10]	
5	55.7 [11]		5	13.9 [11]																

TABLE 2. TYPE 316 STAINLESS STEEL AND A387 STEEL DATA COMPILED FROM THE LITERATURE

Yield Stress of Annealed 316 SS at 4E-3 /s						316 SS Yield Stress (5% Cold Work)			316 SS Yield Stress (10% Cold Work)			A387 Grade 22 (Normalized and Tempered)			
3/4 in. Bar			1/8 Sheet			Temp	YS		Temp	YS		Temp	YS (ksi)		
Temp (°F)	YS (ksi)	Ref	Temp (°F)	YS (ksi)	Ref	(°F)	(ksi)	Ref	(°F)	(ksi)	Ref	(°F)	Annealed	CW	Ref
68	34.2	[13]	77	30.4	[14]	68	54.8	[13]	68	68.5	[13]	68	39.8	64.0	[17]
1400	16.4	[13]	500	22.3	[14]	1400	26	[13]	1400	31.6	[13]	212	35.6	59.7	[17]
1800	8.35	[13]	1000	18.1	[14]	1600	18.6	[13]	1600	20.3	[13]	392	35.6	55.5	[17]
2000	4.35	[13]	1400	12.7	[14]	1800	8.7	[13]	1800	10	[13]	572	32.7	54.1	[17]
2200	3	[13]	1600	9.6	[14]							752	34.1	54.1	[17]
2300	2.36	[13]	1800	5	[14]							842	31.3	51.2	[17]
												932	31.3	48.4	[17]
Yield Stress of As-Received 316L SS						Strain Rate Sensitivity of 316L SS						1022	28.4	44.1	[17]
68°F	68°F		1022°F	1022°F		Strain Rate	m		Strain Rate	m		1112	24.2	37.0	[17]
Rate (/s)	YS (ksi)	Ref	Rate (/s)	YS (ksi)	Ref	(/s)	(68 F)	Ref	(/s)	(1022°F)	Ref	1202	19.9	28.4	[17]
4.00E-03	46	[15]	3.50E-04	21	[16]										
15	65	[15]	3.50	26	[16]	3.50E-02	0.042	[15]	3.50E-02	0.023	[16]				
			7.80E+02	33	[16]				5.22E+01	0.044	[16]				

NSWCDD/TR-98/72

20

APPENDIX A
TITANIUM ALLOY TEST DATA

TABLE A-1. TITANIUM ALLOY DATA FROM TESTS AT ROOM TEMPERATURE (68°F)

Titanium Alloy Test Data															
Temp: 20°C															
Strain Rate (/s)				100E-6	1E-3	100E-6	10E-3	100E-6	10E-3	100E-6	10E-3	100E-6	10E-3	10 ⁻⁴ /s -> 0.01/s	10 ⁻⁴ /s -> 0.01/s
ALLOY	Heat Treat*	Test	Strain Rate Test Type	0.2% Y.S. (ksi)	Y.S.**** (ksi)	ENGR UTS (ksi)	ENGR UTS (ksi)	True Fracture (ksi)	True Fracture (ksi)	%RA	%RA**	%Elong	%Elong	N	m
TIMETAL 21S	593 C, 8 h	#1	Constant	145		154		191		28.1		20.8			
TIMETAL 21S	480 C, 20 h	#2	Constant	200		206		224		9.2		8.3			
TIMETAL 21S	480 C, 20 h	#3	Change	208	212		220		242		9.7		6.9	122	0.0082
Ti-6-4	540 C, 4 h	#1**	Constant	***		153		178		14.6		13.5			
Ti-6-4	540 C, 4 h	#2	Change	146	150		161		191		25.9		18.4	88	0.0114
Ti-15-3	510 C, 14 h	#1	Constant	171		184		211		19.9		13.8			
Ti-15-3	510 C, 14 h	#2	Change	175	178		195		214		20.0		12.3	129	0.0078
Ti-13-11-3	480 C, 72 h	#1	Constant	137		141		147		4.4		4.0			
Ti-13-11-3	480 C, 72 h	#2	Change	140	143		152		157		3.5		3.5	108	0.0093
Beta C	480 C, 16 h	#1	Constant	150		160		185		14.8		11.6			
Beta C	480 C, 16 h	#2	Change	148	151		165		188		15.0		12.0	122	0.0082
Beta III	480 C, 8 h	#3	Change	176	183		204		220		10.5		7.5	62	0.0161
*All specimens solution treated at 815°C for 15 min prior to aging at temperatures and times indicated.															
**Test #1 of the Ti-6-4 broke near the shoulder. This may have been a premature fracture, resulting in lower ductility and UTS.															
***Data point not definable on Load vs. Elongation curve.															
****Yield stress is calculated using the constant structure stress exponent, N.															

TABLE A-2. TITANIUM ALLOY DATA FROM TESTS AT 2000°F

Titanium Alloy Test Data															
Temp: 1093°C*															
Strain Rate (/s)			1E-3	10E-3	10E-3	20E-3	20E-3	20E-3	20E-3	50E-3	50E-3	50E-3	50E-3	10 ⁻³ /s -> 0.01/s	10 ⁻³ /s -> 0.01/s
ALLOY	Test	Strain Rate Test Type	0.2% Y.S. (ksi)	0.2% Y.S. (ksi)	ENGR UTS (ksi)	0.2% Y.S. (ksi)	ENGR UTS (ksi)	%RA	Percent Elong to Fracture	0.2% Y.S. (ksi)	ENGR UTS (ksi)	%RA	Percent Elong to Fracture	N	m
TIMETAL 21S*	#1	Constant				**	5.26	97.1	164						
TIMETAL 21S	#2	Change	1.47	3.96	3.96									2.97	0.34
Ti-6-4	#2	Change	0.63	1.50	1.50									2.65	0.38
Ti-15-3	#1	Change	1.65	3.53	3.53									2.56	0.39
Ti-13-11-3	#1	Change	1.45	4.01	4.01									2.45	0.41
Beta C	#1	Change	1.09	2.94	3.03									2.88	0.35
Beta III	#1	Change	1.66	3.89	4.26									3.15	0.32
Beta III*	#2	Constant								**	6.51	98.2	192		
AVERAGE														2.4	0.31
*Temperature measured at opposite ends/sides of specimen gage length varied less than 10°C. Overall temperature increased by less than 30°C during plastic deformation.															
**Stress/strain curve not defined well enough to determine a 0.2% yield stress (this was a problem with the data acquisition).															

A-4

TABLE A-3. TITANIUM ALLOY DATA FROM TESTS AT 2400°F

Titanium Alloy Test Data											
Temp: 1316°C*											
Strain Rate (/s)			1E-3	10E-3	10E-3	10E-3	10 ⁻³ /s -> 0.01/s	10 ⁻³ /s -> 0.01/s	10 ⁻³ /s -> 0.01/s	10 ⁻³ /s -> 0.01/s	1E-3
ALLOY	Test	Tensile Test Type	0.2% Y.S. (ksi)	0.2% Y.S. (ksi)	ENGR UTS (ksi)	True Stress (ksi)**	%RA**	%Elong**	N	m	Q (kcal/mol)
TIMETAL 21S	#1	Strain Rate Change	0.44	1.84	1.89	1.78	14.4	25.8	2.29	0.44	61.3
Ti-6-4	#1	Strain Rate Change	0.24	0.68	0.68	0.70	16.9	30.5	2.43	0.41	47.4
Ti-15-3	#1	Strain Rate Change	0.61	1.58	1.58	1.39	14.8	31.8	1.67	0.60	40.6
Ti-13-11-3	#1	Strain Rate Change	0.33	1.48	1.48	1.37	18.3	29.5	3.07	0.33	79.0
Beta C	#1	Strain Rate Change	0.40	1.34	1.36	1.28	19.9	32.0	2.77	0.36	54.7
Beta III	#1	Strain Rate Change	0.30	2.02	2.06	1.97	14.9	31.8	2.62	0.38	95.4
AVERAGE									2.5	0.42	63

*Temperature measured along specimen gage length varied less than 10°C. Temperature increased by less than 30°C during plastic deformation

**True stress, Percent Reduction in Area, and Elongation measured not at fracture, but at the point where the test was stopped.

Elongation based on total specimen deformation divided by initial gage length. Some deformation took place in the shoulders of the specimen.

***Activation energy, Q calculated at a constant strain rate using change in YS from 1093° to 1316°C (average stress exponent used).

DISTRIBUTION

	<u>Copies</u>		<u>Copies</u>
DOD ACTIVITIES (CONUS)		ATTN RADM PELAEZ	1
DEFENSE TECH INFORMATION CTR		NEWPORT NEWS SHIPBUILDING INC	
8725 JOHN J KINGMAN RD		4101 WASHINGTON AVE	
SUITE 0944		NEWPORT NEWS VA 23607	
FORT BELVOIR VA 22060-6218	2	ATTN DD-21 PM	
		(MR TOM REDDY)	1
ATTN CODE A76		PEO-DD-21 AND ASSOCIATED	
(TECHNICAL LIBRARY)	1	TECHNOLOGIES	
COMMANDING OFFICER		NATIONAL CENTER 2 6S14	
CSSDD NSWC		2531 JEFFERSON DAVIS HIGHWAY	
6703 W HIGHWAY 98		ARLINGTON VA 22242-5165	
PANAMA CITY FL 32407-7001			
		ATTN MR JOHNDROW	1
ATTN CODE N43		PEO (TAD) PMS410 SURFACE LAUNCHING	
(RADM KNAPP)	1	SYSTEMS	
COMMANDER		NATIONAL CENTER 2 7NXX	
NAVAL SURFACE FORCE		2531 JEFFERSON DAVIS HIGHWAY	
U S ATLANTIC FLEET		ARLINGTON VA 22242-5165	
1430 MITSCHER AVE			
NORFOLK VA 23551-2494		ATTN SEA 09NR	
		(MR WILLIAM KASTNER)	3
ATTN CODE 35		NAVAL RESERVE PROGRAM OFFICE	
(JAMES CHEW)	1	NATIONAL CENTER 3	
(DAVE SIEGEL)	1	2531 JEFFERSON DAVIS HIGHWAY	
(ELI ZIMET)	1	ARLINGTON VA 22242-5165	
OFFICE OF NAVAL RESEARCH			
800 N QUINCY ST		ATTN SEA 03	
ARLINGTON VA 22217-5000		(RADM COYLE)	1
		(CAPT NEEDHAM)	1
ATTN CODE N86	1	CHIEF ENGINEER DEPUTY COMMANDER	
CHIEF OF NAVAL OPERATIONS		FOR ENGINEERING	
SURFACE WARFARE DIVISION		NATIONAL CENTER 3	
2000 NAVY PENTAGON		2531 JEFFERSON DAVIS HIGHWAY	
WASHINGTON DC 20350-2000		ARLINGTON VA 22242-5165	
ATTN MR ALTWEGG	1	ATTN SEA 03M	
PROGRAM EXECUTIVE OFFICE		(MR ALEXIS KAZNOFF)	1
THEATER AIR DEFENSE		MATERIALS ENGINEERING GROUP	
NATIONAL CENTER 2 8N06		NATIONAL CENTER 4	
2531 JEFFERSON DAVIS HIGHWAY		2531 JEFFERSON DAVIS HIGHWAY	
ARLINGTON VA 22242-5170		ARLINGTON VA 22242-5165	

DISTRIBUTION (Continued)

	<u>Copies</u>		<u>Copies</u>
ATTN SEA 03K (MR PETERIS PRIKALS JR) SEA 03K2 (MR DONALD CEBULSKI)	1 3	ATTN ROBERT S ROSEN LAWRENCE LIVERMORE NATIONAL LABORATORY 20201 CENTURY BLVD 1 ST FLOOR GERMANTOWN MD 20874	25
COMBAT SYSTEMS DESIGN AND ENGINEERING GROUP NATIONAL CENTER 2 2531 JEFFERSON DAVIS HIGHWAY ARLINGTON VA 22242-5165		ATTN MICHAEL E KASSNER DEPARTMENT OF MECHANICAL ENGINEERING ROGERS HALL 414 OREGON STATE UNIVERSITY CORVALLIS OR 97331-6001	10
ATTN CAPT FOSKETT COMMANDING OFFICER NAVAL RESERVE UNIT PMS TNW 106 NAVAL AND MARINE CORPS RESERVE CENTER NAVAL STATION WASHINGTON BLDG 351 2701 SOUTH CAPITAL ST SW WASHINGTON DC 20373-5812	3	ATTN MR SAMUEL MARSHALL LOCKHEED MARTIN CORPORATION 1725 JEFFERSON DAVIS HIGHWAY CRYSTAL SQUARE 2 SUITE 300 ARLINGTON VA 22042-4127	1
ATTN HOWARD BOWMAN HEAD FIRE RESEARCH OFFICE RESEARCH AND TECHNOLOGY DIV NAVAL AIR WARFARE CENTER WEAPONS DIVISION CODE 474310D CHINA LAKE CA 93555-6001	1	ATTN MR DAVID JOHNSON MR NEIL ANDERSON MR MICHAEL SANTORO UNITED DEFENSE LP ARMAMENT SYSTEMS DIVISION 4800 EAST RIVER ROAD MINNEAPOLIS MINNESOTA 55421	1 1 1
ATTN MILTON SCATURRO CODE 4A08 NAVAL SURFACE WARFARE CENTER PORT HUENEME DIVISION 4363 MISSILE WAY PORT HUENEME CA 93043-4307	1	ATTN MR JOAQUIM TAVARES NORTHROP GRUMMAN CORPORATION POST OFFICE BOX 3499 MS 21-3 SUNNYVALE CA 94088-3499	1
ATTN IVAN CAPLAN CODE 0115 CARDEROCK DIVISION NAVAL SURFACE WARFARE CENTER 3A LEGGETT CIRCLE ANNAPOLIS MD 21402	1	ATTN JAMES CECH HUGHES NAVAL AND MARITIME SYS 2001 JEFFERSON DAVIS HIGHWAY SUITE 703 CRYSTAL PLAZA 1 ARLINGTON VA 22202-3602	1
NON-DOD ACTIVITIES (CONUS)		ATTN FRANCIS LUNSFORD GENERAL DYNAMICS LAND SYSTEMS DIVISION P O BOX 2074 WARREN MI 48090-5075	1
THE CNA CORPORATION P O BOX 16268 ALEXANDRIA VA 22302-0268	1	ATTN AL DILLINGHAM ASTECH MCI MANUFACTURING INC 3030 RED HILL AVE SANTA ANA CA 92705-5866	1

DISTRIBUTION (Continued)

	<u>Copies</u>		<u>Copies</u>
ATTN MICHAEL SCHERR PROGRAM EXECUTIVE OFFICE UNDERSEA WARFARE PMO 406A 2531 JEFFERSON DAVIS HWY ARLINGTON VA 22242-5169	1	ATTN PROF WILLIAM BAESLACK COLLEGE OF ENGINEERING OHIO STATE UNIVERSITY 208 BRICKER HALL COLUMBUS OH 43210	1
ATTN RICHARD FREER OCEAN SYS ENGINEERING CORP 1734 ELTON ROAD SUITE 219 SILVER SPRING MD 20903	1	ATTN WILLIAM LOVE RMI TITANIUM COMPANY 1000 WARREN AVE P O BOX 269 NILES OH 44446-0269	1
ATTN A ROSS COHEN ROSS COHEN ASSOCIATES 1651 S DILLON MESA AZ 85208-4698	1	ATTN AARON HENNAGAN TITANIUM METALS CORPORATION PO BOX 2128 HENDERSON, NV 89015	1
ATTN ROBERT STRANGE NKF ENGINEERING INC 2100 S WASHINGTON BLVD SUITE 2119 ARLINGTON VA 22204-5710	1	INTERNAL	
		B60 (TECHNICAL LIBRARY)	3
		G20	10
		G21 (MILLS)	10
		G21 (POFF)	1
		G50	2
ATTN ALFRED WHITTLE III MARTIN MARIETTA AERO AND NAVAL SYSTEMS 103 CHESAPEAKE PARK PLAZA BALTIMORE MD 21220	1	G704 (YAGLA)	10
		G72	10
		G72 (LOWRY)	10
ATTN JAMES WILLIAMS LORAL VOUGHT SYSTEMS P O BOX 650003 MS WT-10 DALLAS TX 75265-0003	1		
ATTN JOANNE BECKMAN CRUCIBLE MATERIALS CORPORATION 6003 CAMPBELLS RUN ROAD PITTSBURGH PA 15205	1		
ATTN PAUL BANIA TITANIUM METALS CORPORATION 1999 BROADWAY DENVER CO 80202	1		
ATTN FRANK LUCIA METALS UNLIMITED 1372 BENNETT DRIVE UNIT 100 LONGWOOD FL 32750	1		

