

NUREG/IA-0134  
CAMP005



# International Agreement Report

---

---

## Assessment of RELAP5/MOD3.1 for Gravity-Driven Injection Experiment in the Core Makeup Tank of the CARR Passive Reactor (CP-1300)

Prepared by  
Sang Il Lee, Hee Cheon No, KAIST  
Young Seok Bang, Hho Jung Kim, KINS

Korea Advanced Institute of Science and Technology  
Nuclear Engineering Department  
373-1, Gusung-Dong  
Yusung, Taejon  
305-701 Korea

Korea Institute of Nuclear Safety  
Advanced Reactor Dept.  
P.O. Box 114  
Yusung, Taejon  
305-600 Korea

Office of Nuclear Regulatory Research  
U.S. Nuclear Regulatory Commission  
Washington, DC 20555-0001

**October 1996**

Prepared as part of  
The Agreement on Research Participation and Technical Exchange  
under the International Thermal-Hydraulic Code Assessment  
and Maintenance Program (CAMP)

**Published by  
U.S. Nuclear Regulatory Commission**

RECEIVED  
OCT 30 1996  
OSTI

**MASTER**

## AVAILABILITY NOTICE

### Availability of Reference Materials Cited in NRC Publications

Most documents cited in NRC publications will be available from one of the following sources:

1. The NRC Public Document Room, 2120 L Street, NW., Lower Level, Washington, DC 20555-0001
2. The Superintendent of Documents, U.S. Government Printing Office, P. O. Box 37082, Washington, DC 20402-9328
3. The National Technical Information Service, Springfield, VA 22161-0002

Although the listing that follows represents the majority of documents cited in NRC publications, it is not intended to be exhaustive.

Referenced documents available for inspection and copying for a fee from the NRC Public Document Room include NRC correspondence and internal NRC memoranda; NRC bulletins, circulars, information notices, inspection and investigation notices; licensee event reports; vendor reports and correspondence; Commission papers; and applicant and licensee documents and correspondence.

The following documents in the NUREG series are available for purchase from the Government Printing Office: formal NRC staff and contractor reports, NRC-sponsored conference proceedings, international agreement reports, grantee reports, and NRC booklets and brochures. Also available are regulatory guides, NRC regulations in the *Code of Federal Regulations*, and *Nuclear Regulatory Commission Issuances*.

Documents available from the National Technical Information Service include NUREG-series reports and technical reports prepared by other Federal agencies and reports prepared by the Atomic Energy Commission, forerunner agency to the Nuclear Regulatory Commission.

Documents available from public and special technical libraries include all open literature items, such as books, journal articles, and transactions. *Federal Register* notices, Federal and State legislation, and congressional reports can usually be obtained from these libraries.

Documents such as theses, dissertations, foreign reports and translations, and non-NRC conference proceedings are available for purchase from the organization sponsoring the publication cited.

Single copies of NRC draft reports are available free, to the extent of supply, upon written request to the Office of Administration, Distribution and Mail Services Section, U.S. Nuclear Regulatory Commission, Washington, DC 20555-0001.

Copies of industry codes and standards used in a substantive manner in the NRC regulatory process are maintained at the NRC Library, Two White Flint North, 11545 Rockville Pike, Rockville, MD 20852-2738, for use by the public. Codes and standards are usually copyrighted and may be purchased from the originating organization or, if they are American National Standards, from the American National Standards Institute, 1430 Broadway, New York, NY 10018-3308.

## DISCLAIMER NOTICE

This report was prepared under an international cooperative agreement for the exchange of technical information. Neither the United States Government nor any agency thereof, nor any of their employees, makes any warranty, expressed or implied, or assumes any legal liability or responsibility for any third party's use, or the results of such use, of any information, apparatus, product, or process disclosed in this report, or represents that its use by such third party would not infringe privately owned rights.

## DISCLAIMER

This report was prepared as an account of work sponsored by an agency of the United States Government. Neither the United States Government nor any agency thereof, nor any of their employees, makes any warranty, express or implied, or assumes any legal liability or responsibility for the accuracy, completeness, or usefulness of any information, apparatus, product, or process disclosed, or represents that its use would not infringe privately owned rights. Reference herein to any specific commercial product, process, or service by trade name, trademark, manufacturer, or otherwise does not necessarily constitute or imply its endorsement, recommendation, or favoring by the United States Government or any agency thereof. The views and opinions of authors expressed herein do not necessarily state or reflect those of the United States Government or any agency thereof.

**DISCLAIMER**

**Portions of this document may be illegible  
in electronic image products. Images are  
produced from the best available original  
document.**





NUREG/IA-0134  
CAMP005

# International Agreement Report

---

---

## Assessment of RELAP5/MOD3.1 for Gravity-Driven Injection Experiment in the Core Makeup Tank of the CARR Passive Reactor (CP-1300)

Prepared by  
Sang Il Lee, Hee Cheon No, KAIST  
Young Seok Bang, Hho Jung Kim, KINS

Korea Advanced Institute of Science and Technology  
Nuclear Engineering Department  
373-1, Gusung-Dong  
Yusung, Taejon  
305-701 Korea

Korea Institute of Nuclear Safety  
Advanced Reactor Dept.  
P.O. Box 114  
Yusung, Taejon  
305-600 Korea

Office of Nuclear Regulatory Research  
U.S. Nuclear Regulatory Commission  
Washington, DC 20555-0001

**October 1996**

Prepared as part of  
The Agreement on Research Participation and Technical Exchange  
under the International Thermal-Hydraulic Code Assessment  
and Maintenance Program (CAMP)

**Published by  
U.S. Nuclear Regulatory Commission**

HH  
DISTRIBUTION OF THIS DOCUMENT IS UNLIMITED

NUREG/IA-0134 has been reproduced  
from the best available copy.

**Assessment of RELAP5/MOD3.1 for Gravity-Driven Injection  
Experiment in the Core Makeup Tank of the CARR Next Generation  
Reactor**

**Abstract**

The objective of the present work is to improve the analysis capability of RELAP5/MOD3.1 on the direct contact condensation in the core makeup tank (CMT) of passive high-pressure injection system (PHPIS) in the CARR Passive Reactor (CP-1300). The gravity-driven injection experiment is conducted by using a small scale test facility to identify the parameters having significant effects on the gravity-driven injection and the major condensation modes. It turns out that the larger the water subcooling is, the more the initiation of injection is delayed, and the sparger and the natural circulation of the hot water from the steam generator accelerate the gravity-driven injection. The condensation modes are divided into three modes: sonic jet, subsonic jet, and steam cavity. RELAP5/MOD3.1 is chosen to evaluate the code predictability on the direct contact condensation in the CMT. It is found that the predictions of MOD3.1 are in better agreement with the experimental data than those of MOD3.0. From the nodalization study of the test section, the 1-node model shows better agreement with the experimental data than the multi-node models. RELAP5/MOD3.1 identifies the flow regime of the test section as vertical stratification. However, the flow regime observed in the experiment is the subsonic jet with the bubble having the vertical cone shape. To accurately predict the direct contact condensation in the CMT with RELAP5/MOD3.1, it is essential that a new set of the interfacial heat transfer coefficients and a new flow regime map for direct contact condensation in the CMT be developed.

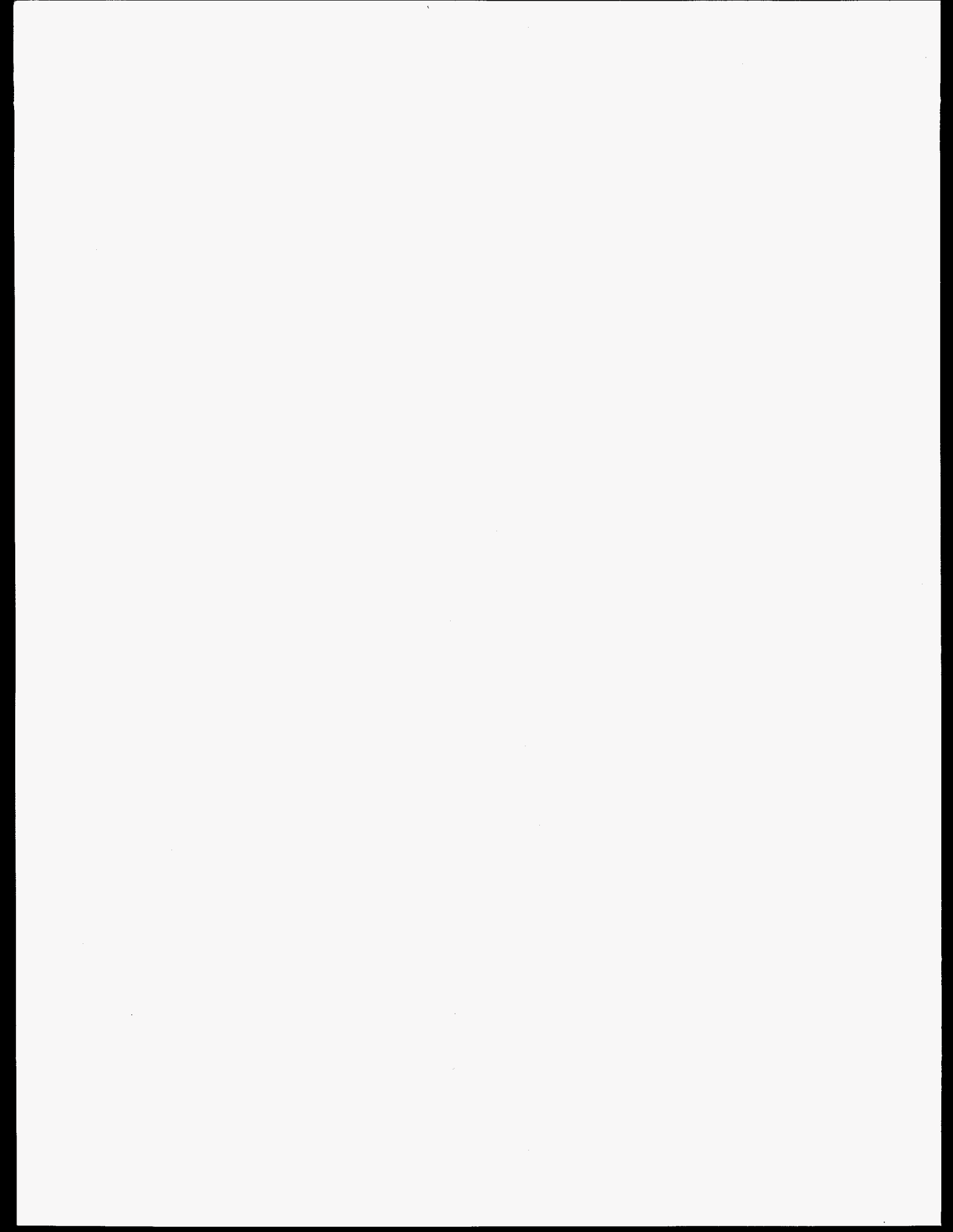

# Contents

Abstract	iii
Table of Contents	v
List of Tables	vii
List of Figures	viii
Executive Summary	xi
Acknowledgment	xv
<b>1 Introduction</b>	<b>1</b>
1.1 Background . . . . .	1
1.2 Objectives and report organization . . . . .	3
<b>2 Gravity-Driven Injection Experiment</b>	<b>6</b>
2.1 Experimental setup and instrumentation . . . . .	6
2.2 Test procedure . . . . .	9
2.3 Experimental results . . . . .	10
2.3.1 Effects of water subcooling on gravity-driven injection . .	10
2.3.2 Effects of natural circulation on gravity-driven injection .	11

2.3.3	Effects of the sparger on gravity-driven injection . . . . .	12
2.3.4	Effects of the pressure on gravity-driven injection . . . . .	13
2.3.5	Identification of condensation modes . . . . .	13
<b>3</b>	<b>Assessment of RELAP5/MOD3.1</b>	<b>35</b>
3.1	Description of code and modeling . . . . .	35
3.2	Analysis results and discussion . . . . .	36
3.2.1	Base case . . . . .	36
3.2.2	Sensitivity study . . . . .	38
3.2.3	Nodalization study . . . . .	39
3.2.4	Run statistics . . . . .	40
<b>4</b>	<b>Conclusions</b>	<b>61</b>
	<b>Bibliography</b>	<b>63</b>
	<b>Appendices: Input Decks and Experimental data</b>	<b>65</b>

# List of Tables

1.1	Summary of condensation regime map . . . . .	4
2.1	Tag list for the KARD-I instrument . . . . .	16
2.2	Test matrix . . . . .	17
2.3	Transition time between subsonic jet and steam cavity, and injection time . . . . .	18
3.1	Grind time . . . . .	42

# List of Figures

1.1	A schematic diagram of CARR Next Generation Reactor . . . . .	5
2.1	A systematic diagram of test facility . . . . .	19
2.2	A systematic diagram of test section . . . . .	20
2.3	The pressure trend for test GI021 . . . . .	21
2.4	The effect of water subcooling on the injection flow rate for test GI021, GI022, and GI023 . . . . .	22
2.5	The temperature distribution of test section for test GI021 . . . . .	23
2.6	The effect of the natural circulation on the injection flow rate for test GI021 and GN021 . . . . .	24
2.7	The comparison of the natural circulation flow with the injection flow rate for test GN021 . . . . .	25
2.8	The temperature distribution of test section for test GN021 . . . . .	26
2.9	The effect of the sparger on the injection flow rate for test GI021 and GS021 . . . . .	27
2.10	The temperature distribution of test section for test GS021 . . . . .	28
2.11	The effect of the high pressure on the injection flow rate for test GI021 and PI021 . . . . .	29
2.12	The pressure trend for test PI041 . . . . .	30
2.13	The injection flow rate at 4bar for test PI041, PN041, and PS041 . . . . .	31
2.14	Sonic jet . . . . .	32



2.15	Subsonic jet . . . . .	33
2.16	Steam cavity . . . . .	34
3.1	A systematic diagram of RELAP5 nodalization . . . . .	43
3.2	Comparison of the steam generator pressure between experiments and calculation . . . . .	44
3.3	Comparison of the test section pressure between experiments and calculation . . . . .	45
3.4	Comparison of the pool water temperature between experiments and calculation . . . . .	46
3.5	Comparison of the steam flow rate between experiments and cal- culation . . . . .	47
3.6	Comparison of the injection flow rate between experiments and calculation . . . . .	48
3.7	Comparison of the water level between experiments and calculation	49
3.8	Comparison of the pressure of the steam generator and the test section between test GI021 and calculation(MOD3.0 vs MOD3.1)	50
3.9	Comparison of the pool water temperature between test GI021 and calculation(MOD3.0 vs MOD3.1) . . . . .	51
3.10	Comparison of the steam flow rate between test GI021 and calcu- lation(MOD3.0 vs MOD3.1) . . . . .	52
3.11	Comparison of the injection flow rate between test GI021 and cal- culation(MOD3.0 vs MOD3.1) . . . . .	53
3.12	Comparison of the water level between test GI021 and calcula- tion(MOD3.0 vs MOD3.1) . . . . .	54
3.13	Comparison of the pressure of the steam generator and the test section between test GI021 and calculation(Nodalization study) .	55

3.14 Comparison of the pool water temperature between test GI021 and calculation(Nodalization study) . . . . .	56
3.15 Comparison of the steam flow rate between test GI021 and calculation(Nodalization study) . . . . .	57
3.16 Comparison of the injection flow rate between test GI021 and calculation(Nodalization study) . . . . .	58
3.17 Comparison of the water level between test GI021 and calculation(Nodalization study) . . . . .	59
3.18 CPU time and time step size . . . . .	60

## Executive Summary

At Center for Advanced Reactor Research(CARR) in Korea a passive PWR concept named CARR Passive Reactor(CP-1300) has been developed by adopting a passive engineered-safety-feature-system. The CP-1300 passive safety injection system consists of passive high-pressure injection system(PHPIS), accumulator, and in-containment refueling water storage tank(IRWST), which are used to supply emergency core cooling water at high, intermediate, and low pressure, respectively. The PHPIS consists of the core makeup tanks(CMTs) with a sparger and the pressurizer-pressure balancing line. The PHPIS can provide cold water at any RCS pressure by gravity force because the pressure of the CMT is equilibrated with the RCS through lines connecting the inlet of the CMT to the pressurizer.

RELAP5 code has been developed as one of the best-estimate codes. The code is based on a non-homogeneous and non-equilibrium model for one dimensional, two-phase flow. Recently, RELAP5 code development program has been initiated to develop a code version suitable for the safety analysis of passive advanced reactors like the CP-1300. However, there is no model in RELAP5 that can deal with the direct contact condensation of steam in the pool like the CMT of the PHPIS.

The objective of the present work is to improve the analysis capability of the RELAP5/MOD3.1 on the direct contact condensation in the CMT of the PHPIS. The gravity-driven injection experiment is conducted by using a small scale test facility to identify the parameter governing the gravity-driven injection

and the major phenomena. To evaluate the code predictability on the direct contact condensation in the CMT, the base case studies are performed on the experiments. Also, a sensitivity study is performed on two code versions (MOD3.0 vs MOD3.1). Finally, the effect of the node number of the test section on the gravity driven injection is investigated. From the present study, the following conclusions are obtained:

- The experimental results show that the lower the water temperature is, the longer the initiation time of injection is delayed, and the sparger and the natural circulation from the hot water in the steam generator accelerate the gravity-driven injection. The condensation modes identified through the experiments are divided into three modes: sonic jet, subsonic jet, and steam cavity. The steam cavity is the unique mode of downward injection with a solid surface directly connected to the pipe exit not seen in other experiments.
- RELAP5/MOD3.1 better predicts the experiment data of the water level at 4 bar than that at 1.5 bar. However, the calculated results are not in good agreement with the other measurement parameters, such as the pressures of the steam generator and the test section, the pool temperature, the flow rate of steam and injection, the test section water level.
- The overall prediction capabilities of RELAP5/MOD3.0 and MOD3.1 are poor. However, the predictions of RELAP5/MOD3.1 are in better agreement with the experimental data than those of RELAP5/MOD3.0. MOD3.0 and MOD3.1 identify the flow regime of the test section as vertical stratification, and they have the same heat transfer correlation of the vertical stratification. It is not clear the reason why MOD3.1 better predicts the experimental data than MOD3.0.

- From the nodalization study of RELAP5/MOD3.1, the 1-node model shows better agreement with the experimental data than multi-node models. However, considering the penetration depth of the jetting, the proper node number of the CMT must be determined.
- To accurately predict the direct contact condensation in the CMT by the RELAP5/MOD3.1, it is necessary that a new set of the interfacial heat transfer coefficients and a new flow regime map for the direct contact condensation in the CMT be developed. The new set of the interfacial heat transfer coefficients and the flow regime map should capture the physical process of the direct contact condensation in the CMT.

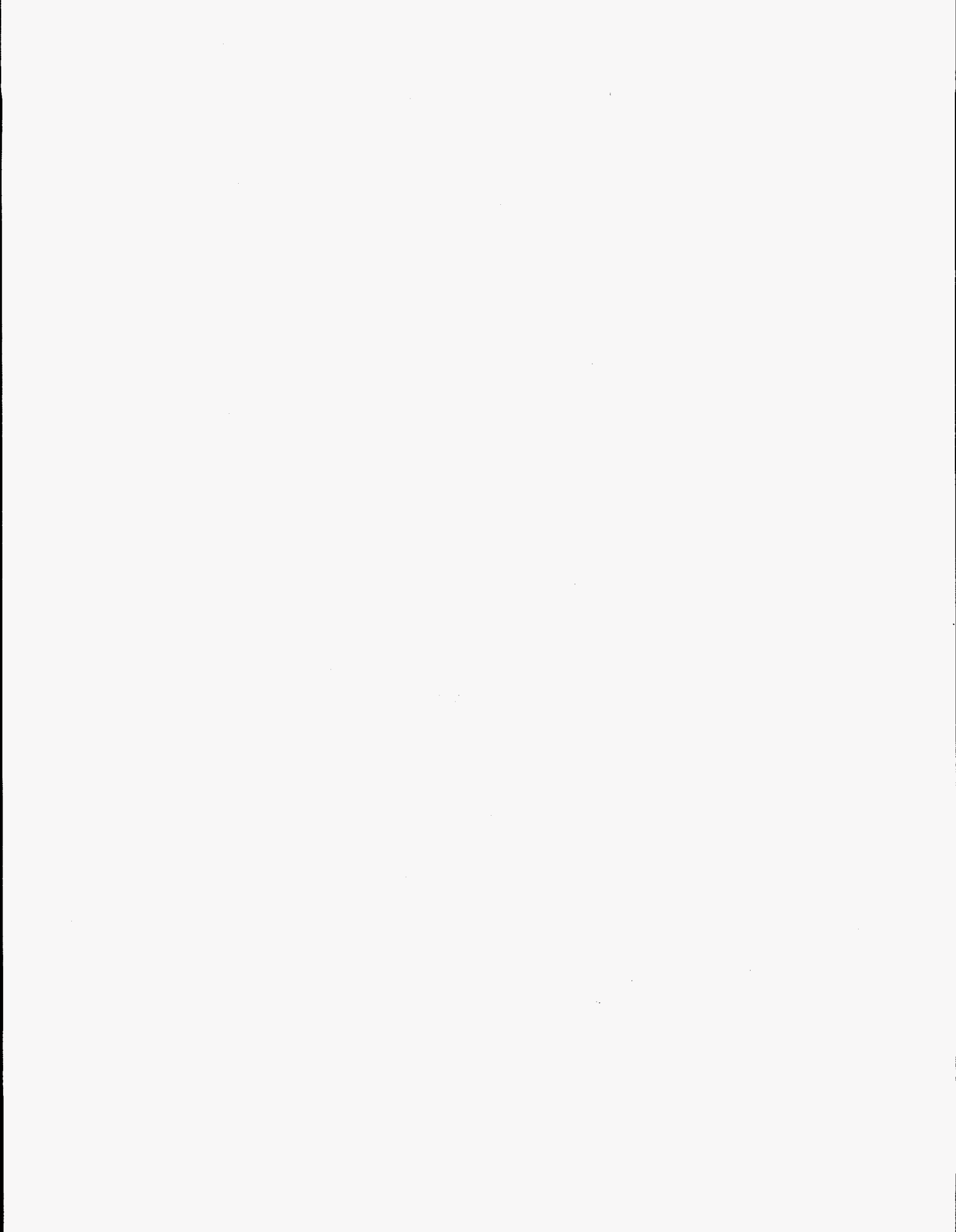

## Acknowledgment

This report was performed under the sponsorship of Korea Science and Engineering Foundation(KOSEF). Authors appreciate the KOSEF for the financial support.

# Chapter 1

## Introduction

### 1.1 Background

At Center for Advanced Reactor Research(CARR) in Korea, a passive PWR concept named CARR Next Generation Reactor(CP-1300) has been developed by adopting a passive engineered-safety-feature-system as shown in Figure 1.1. The CP-1300 is a large passive PWR with the power of 1300MWe because of limitations on plant site size and a decrease of construction costs per power. The CP-1300 adopts the core of Korea Standard Nuclear Power Plant(KSNPP) such as YGN units 3 and 4 PWRs and Ulchin units 3 and 4 PWRs. However, the number of fuel assembly is increased to reduce power density. The RCS of the CP-1300 consists of 2 hot legs and 4 cold legs (2 loop), which is the same as those of KSNPP and System 80+. Instead of canned motor pumps used in AP600, sealed pumps are used. A natural circulation loop is installed in the secondary side of each S/G to achieve passive residual heat removal system(PRHRS). In addition, 2 natural circulation loops serve as passive containment cooling system(PCCS). The CP-1300 passive safety injection system consists of Passive High-Pressure Injection System(PHPIS), accumulators, and In-Containment Refueling Water Storage Tank(IRWST), which are used to supply emergency core cooling water



at high, intermediate, and low pressure, respectively. In order to provide RCS with IRWST water at low pressure, automatic depressurization system(ADS) is installed.

The PHPIS consists of the core makeup tanks(CMTs) with a sparger and the pressurizer balancing line. The PHPIS can provide cold water at any RCS pressure by gravity force because the pressure of the CMT is equilibrated with the reactor coolant system through lines connecting the inlet of the CMT to the pressurizer. The major merit of the PHPIS is that it is considered to have a potential to establish a more reliable means to replenish the reactor coolant inventory without operator's intervention. Despite such a potential of the gravity-driven injection system, there are few published experimental data showing its thermal-hydraulic characteristics, especially the direct contact condensation phenomena of steam in the CMT. A rigorous study of the effect of direct contact condensation on the injection of the CMT is required for the design of passive safety injection system.

RELAP5/MOD3.1 [1] developed at Idaho National Engineering Laboratory (IN-EL) is a highly generic code to calculate the behavior of a reactor coolant system during a transient. The application of this code includes analysis required to support licensing audit calculation, evaluation of accident mitigation strategies, and experiment planning and analysis. However, there is no model in RELAP5 that can deal with the direct contact condensation of steam in the pool like the CMT. To simulate the licensing accidents of Passive Advanced Reactors like the CP-1300 by using RELAP5, it is essential to develop the condensation regime map and the model for the interfacial heat transfer coefficients of the direct contact condensation of steam in the pool. Since the interfacial heat transfer coefficient for direct contact condensation in the pool is strongly dependent on flow regime, if the regime can not be identified correctly, it is unlikely that we will produce

correct predictions for the associated heat transfer rate. Table 1.1 shows the summary of the condensation regime map related in this study. There is no existing experimental data concerning the transition criteria between the condensation regimes when steam is condensed out of the steam pipe exit in the CMT. Unlike the vent pipe in the BWR suppression pool, the steam pipe is connected to the CMT, and there is a solid boundary directly connected to the pipe exit which inhibits the steam bubble moving upwardly along the tubes.

## 1.2 Objectives and report organization

The present study aims at assessing and improving the analysis capability of the RELAP5/MOD3.1 on the direct contact condensation in the CMT of the PHPIS. For this purpose, first the gravity-driven injection experiment is conducted by using a small scale test facility named KARD-I(KAIST Experiments for Advanced Reactor Development-I) to investigate the effect of the direct contact condensation on the gravity-driven injection and the major condensation modes.

Secondly, the gravity injection experiment is simulated by RELAP5/MOD3.1 to evaluate whether or not it can describe the direct contact condensation occurring in the top of the test section.

The following material is contained in this report. Chapter 2 includes a description of experimental facility and conditions and results. In Chapter 3, a code description and modeling of the test facility are described. The calculated results of base cases are discussed in detail with the experimental data. Also, the calculated results of sensitivity studies, nodalization study and run statistics are described in this chapter. Chapter 4 summarizes the conclusions through the present study. Finally, the RELAP5 input deck and the experimental data are attached as Appendix A and B, respectively.

Table 1.1: Summary of condensation regime map

author	steam pipe diameter(mm)	water temp.(C)	steam mass flux (Kg/sec $m^2$ )	direction pipe exit shape	regime
Fukuda [5]	8 16.1 27.6	25-90	0 - 350	downward vent pipe	type A : chugging type B : transition type C : subsonic jet type D : oscillatory bubble type E : sonic jet
Chan Lee [6]	51	40 - 90	1 - 175	downward vent pipe	chugging oscillatory bubble ellipsoidal oscillatory bubble ellipsoidal jet oscillatory cone jet
I. Aya H. Nariai [7]	9 - 38	0 -100	40	downward vent pipe	chugging condensation oscillation bubbling
Liang [8]	19.1 10.9	50-100	0-50	upward rectangular channel	chugging bubbling subsonic jet sonic jet

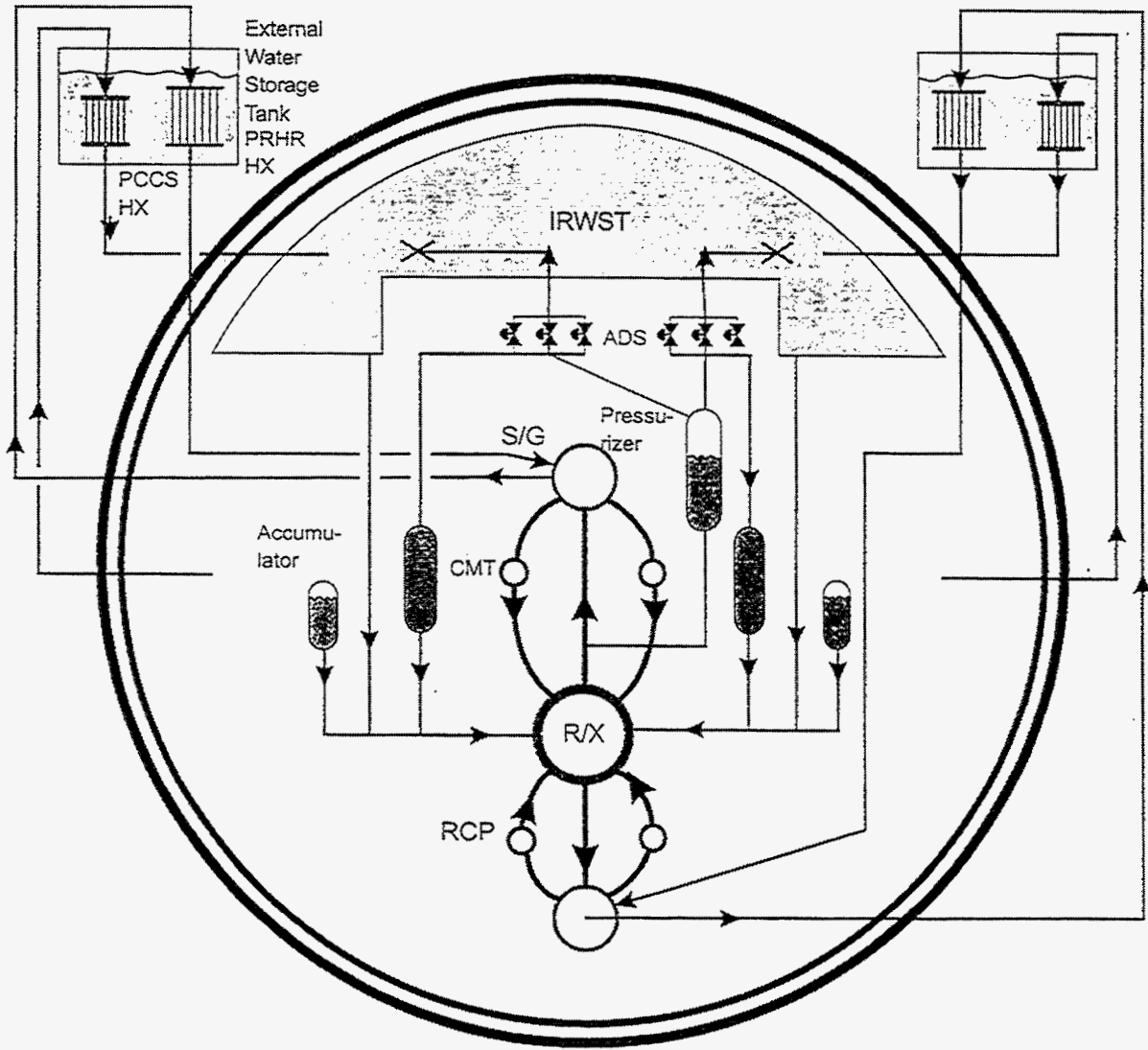

Figure 1.1: A schematic diagram of CARR Next Generation Reactor

## Chapter 2

# Gravity-Driven Injection Experiment

One of the safety concerns is the prevention of the gravity-driven injection because of a large pressure drop in the top of the CMT resulting from the direct contact condensation. The direct contact condensation in the top of the CMT is mainly governed by condensation modes. The objectives of the present experiment are to identify the condensation modes to answer which phenomena are dominant, and investigate the major parameters governing the gravity-driven injection. To these ends, a small scale test facility named KARD-I(KAIST Experiments for Advanced Reactor Development-I) has been constructed, and the experimental work is in progress.

### 2.1 Experimental setup and instrumentation

A diagram of the KARD-I is shown in Figure 2.1. It consists of three major parts: test section simulating the CMT, steam generator simulating the pressurizer, and the measuring system.

The test section includes a heater, a heater controller controlling the water

temperature, front and back visual windows, and drain line as shown in Figure 2.2. The test section is a tank with 85cm height and 65cm diameter. The scaling ratios of the test section relative to the CMT of AP600 are  $\frac{1}{7}$ (height ratio) and  $\frac{1}{36}$ (area ratio), respectively. The visual windows are reinforced glass with 30cm diameter. Through the visual windows, the phenomena occurring at the exit of the steam pipe can be observed and recorded by using a high speed camera. To investigate the vertical temperature distribution of the test section, ten RTDs are installed along the wall of the tank. The heater has a heating capacity of 8 KW to control the test condition of water temperature. Filtered water is used as the working liquid.

The steam generator which functions as a pressurizer is 2 m high, 1 m dia., 10 mm thick cylindrical stainless steel pipe which is connected to the 12-mm-thick stainless steel hemisphere. The total volume is  $1.332 m^3$ . The capacity of the heater is 108 KW. It is located in the lower part of the steam generator in the horizontal direction to prevent uncovering of the heater. Filtered water is supplied to the steam generator and the test section by a pump.

The associated piping lines are the steam feed line and the natural circulation line for hot water from the steam generator. The diameters of these piping lines are 0.015 m and 0.032 m, respectively. The steam feed line is insulated by an asbestos to minimize the heat loss. The injection line from the bottom of the test section has a check valve to prevent air ingress due to a rapid pressure drop.

To measure the chugging boundary, beyond which subcooled water in the tank rushes periodically into the steam path, a thermocouple is installed at the exit of the steam feed line. Ten resistance temperature detectors (RTD) are used for measurement of the vertical distribution of water in the test section. Three vortex flowmeters made by Omega Co. are used to measure the steam flow rates from the steam generator, the drain water flow rate from the bottom of the test

section, and the natural circulation flow of the hot water from the steam generator. The measurement ranges of the flowmeters are  $10 - 90 \text{ kg/m}^2 \text{ sec}$ ,  $0 - 8 \text{ GPM}$ ,  $0 - 25 \text{ GPM}$ , respectively. The pressure of the steam generator is measured by the pressure transducer made by Foxboro Co. The pressure of the test section is measured by two types of pressure transducers made by Foxboro Co. and Omega Co. The PX176 pressure transducer made by Omega Co. has a frequency response of  $10 \text{ KHz}$ , which is sufficient to measure the pressure oscillation of the test section. The water level of the test section can be measured by visual observation because there is a scale on the visual window.

A high speed camera system is used to record the process of the direct contact condensation in the top of the test section, and after the experiment, it can be used to analyze the recorded data.

The data acquisition system consists of HP3852A control unit, 10 channel I-V converter, 8 channel power supply, GPIB card, IBM-PC/AT. The three vortex flowmeters and the three pressure transducers generate DC current signals which vary from 4 to 20mA. The DC current signals are changed into the voltage signals by the I-V converter with 1-5VDC output. The voltage signals from 3 pressure transducers, 1 thermocouple, 3 vortex flowmeter are read by the HP3852A control unit through HP44708H multiplexer. The 10 RTDs are read by the HP3852A control unit through HP44711A high speed multiplexer. Through the GPIB interface card, these readings are transferred to a IBM-PC/AT and displayed on the monitor screen dynamically, and restored in the hard disk.

Table 2.1 shows the tag list for the KARD-I instrumentation. This tag list includes the model number, the measurement range, and the uncertainties of measuring parts (RTDs, pressure transducers, flowmeters). The uncertainties of the data acquisition system and I-V converter is 0.1% and 0.1% respectively. These values are negligible compared with those of the measuring parts.

## 2.2 Test procedure

The test matrix is listed in Table 2.2. In the first part, three tests(GI021, GI022, GI023) are conducted to determine the condensation regimes and the effect of water subcooling on the gravity-driven injection. The fourth and fifth tests(GN021, GS021) investigated the effects of natural circulation of the hot water from the steam generator on the gravity-driven injection and the effects of the sparger on gravity-driven injection, respectively. In the second part, three tests investigated the effects of the high pressure on the gravity injection.

The test procedure is as follows:

*Step1:* The filtered water is filled up to valve  $V_3$ .

*Step2:* The air in the system is initially driven out by the steam generated in the steam generator. Then valves  $V_1$ ,  $V_2$ ,  $V_4$  are opened, while valve  $V_3$  remains closed(Figure 2.1). To ensure the total purging of the air in the system, this process is normally continued for two hours. Then the steam generator remains at atmospheric pressure.

*Step3:* Valve  $V_4$  is closed, and valve  $V_3$  is opened. Opening valve  $V_3$  allows the test section and the steam generator to be the same pressure. The water in the test section is heated to the desired temperature, and simultaneously the steam generator heater is turned on until the steam generator temperature reaches the desired value.

*Step4:* After the test conditions reach the desired point, the data acquisition system and the high speed camera are started to record the data and the interface motion at the pipe exit. After 10 sec, valve  $V_6$  is opened within a second. During the test, the power of the steam generator remains at 8KW to compensate the heat loss of the overall system.

*Step5:* When the water level drops below the visual windows, the experiment is



terminated.

## 2.3 Experimental results

### 2.3.1 Effects of water subcooling on gravity-driven injection

Figure 2.3 shows the pressure trend of the top of the test section for test GI021. As soon as the valve  $V_6$  is opened, the pressure of the test section suddenly drops below atmospheric pressure because the condensation rate is much larger than the steam supply rate.

Figure 2.4 shows the effects of water subcooling on injection flow rates. At  $T_w = 31^\circ C$  and  $T_w = 61^\circ C$ , the test section begins to drain at 1400sec and 2250sec, respectively. At  $T_w = 91^\circ C$ , after the valve  $V_6$  is open, the injection begins immediately due to the fast recovery of the pressure drop between the test section and the steam generator caused by the high water temperature. The result shows that the lower the water temperature is, the more the initiation of injection is delayed.

Figure 2.5 shows a transient of the temperature distribution of the test section for test GI021. As the condensation proceeds, thermal stratification begins to occur at 1250sec. In the early stage of test GI021, the water temperature measured at all RTDs increases. After 1250sec, the temperatures of the upper four RTDs begin to increase, and the rest of RTDs are the constant temperature. It is observed that before 1250sec, the size of the steam bubble is smaller than 2 cm, and the pressure oscillation is vigorous. However, after 1250sec, the transition of the condensation mode begins to occur. At this time, the size of the steam bubble is larger than 4 cm, and the pressure oscillation disappears. It can be therefore stated that the momentum of the steam jet induces circulation of the cold water,

and as a result, the interaction between the cold water and the steam bubble promotes the condensation resulting in the pressure drop as shown in Figure 2.3. When the water begins to inject, the temperatures of the upper four RTDs are about  $80^{\circ}\text{C}$ . It is certain that the thermal stratification exists between 4th RTD and 5th RTD because the temperature difference between 4th RTD and 5th RTD is approximately  $30^{\circ}\text{C}$ .

### 2.3.2 Effects of natural circulation on gravity-driven injection

Recently, the AP600 integral system tests were conducted by using SPES-2 in Italy [10]. In those experiments, the valves in the CMT balancing line and the CMT injection line were simultaneously opened after the S-signal. The results show that the CMT begins to drain, changing from natural circulation operation to steam displacement. This result also shows that there may be a means to enhance the CMT injection performance.

To understand the mechanism of natural circulation in the CMT, the experiment(GN021) was conducted. In this experiment, at the same time of *Step 4*, valve  $V_5$  is opened, which allows a flow between the top of the test section and the midpart of the steam generator, i.e. natural circulation between two tanks. Figure 2.6 shows the effects of natural circulation on the injection flow rate. The result shows that the natural circulation of the hot water from the steam generator accelerates the injection of the test section.

Figure 2.7 shows a comparison between the natural circulation flow rate and the injection flow rate. It is observed that the hot water from the steam generator is jetted into the test section. This is why the trend of natural circulation flow is oscillatory. Until 650s, the water level does not decrease and the injected water is compensated by the natural circulation flow from the steam generator.

After 650s, the water level of the test section begins to decrease, which means a transition from natural circulation to steam displacement.

Figure 2.8 shows the temperature distribution in the test section for test GN021. Thermal stratification does not occur because of the mixing of the hot water. This result shows that the mixing process of the hot water inhibits the thermal stratification and promotes the gravity-driven injection.

### **2.3.3 Effects of the sparger on gravity-driven injection**

To investigate the effect of the sparger on the gravity-driven injection, as shown in Figure 2.2, the sparger is installed 3 cm beneath the exit of the steam feed line. The sparger is the circular disk with 5 mm thickness and 15 mm diameter. Figure 2.9 shows the effects of the sparger on the injection flow rate. This result shows that the sparger promotes the injection of the water in the test section.

Figure 2.10 shows the temperature distributions in the test section for test GS021. It is observed that the thermal stratification occurs between 80cm and 76cm, and the momentum of the steam bubble does not reach the region below 76cm because the sparger changes the vertical direction of the momentum of the steam jet to the horizontal direction. As a result, all the energy of the steam is transferred to the upper hot water layer. Thus, the sparger tends to prohibit the energy of the steam jet from being transferred to the water below the sparger.

The mechanism of the gravity-driven injection with the sparger is different from that from the natural circulation. The former is that the sparger reduces the region affected by the momentum of the steam jet, and all the steam injected into the tank is used to increase the temperature of the upper hot water layer. When the temperature of the upper hot layer is about  $80^{\circ}\text{C}$ , the water begins to inject. The hot water from the steam generator tends to promote circulation of all of water in the test section, and the energy of the hot water and the steam jet

is used to increase the temperature of the bulk water in the test section because the large amount of the hot water from the steam generator is supplied by the pressure difference.

### **2.3.4 Effects of the pressure on gravity-driven injection**

To investigate the effects of the high pressure on the gravity-driven injection, experiments(PI041, PN041, PS041) were conducted at 4 bar. Figure 2.11 shows the effects of the high pressure on the gravity-driven injection. The results show that the gravity-driven injection at 4 bar is initiated much earlier than that at 1.5 bar because the pressure difference between the test section and the steam generator at 4 bar is much larger than at 1.5 bar as shown in Figures 2.3 and 2.12. This causes the large steam flow rate and the high increase of the pool water temperature at 4 bar.

Figure 2.13 shows the effects of the sparger and the natural circulation on the gravity-driven injection at 4 bar. In the case of the natural circulation, before 500sec, the water level in the test section does not drop because the hot water from the steam generator compensates the injection flow rate. After 500sec, the water level begins to drop because the natural circulation flow rate begins to decrease.

### **2.3.5 Identification of condensation modes**

The condensation identified through the experiments are divided into three modes: sonic jet, subsonic jet, steam cavity. The sonic jet can be observed at early stage of GI021 and GI022. Figure 2.14 is the sonic jet having the shape of the inverted cone. If the water temperature increases and the steam velocity decreases, the interface of the sonic jet will start to oscillate and collapse at the tip of the cone. After that, as shown in Figure 2.15, the condensation mode is the subsonic jet in

which the bubble grows, is broken into two parts and collapses.

In test GI021, after 1380s, the cylindrical bubble attached to the exit of the steam feed line as shown in Figure 2.16. This bubble does not collapse but oscillate vertically. After this mode, the water level begins to decrease. To the author's knowledge, there has been no research performed to investigate this mode of condensation. Based on the regime map presented by Chan and Lee [6], the ranges of the water temperature and steam flow rate including this mode correspond to oscillatory bubble regime. The characteristics of oscillatory bubble are that the steam region has expanded to encapsulate part of the pipe and detachment occurs above the vent exit. The geometry of present experiment has the solid boundary to inhibit the steam bubble separating from the steam nozzle. It is believed that this mode may result from the effect of this geometry. This mode is called steam cavity here.

Table 3 shows the time of the initiation of the water injection and the transition between subsonic jet and steam cavity. When the water injection begins, the major regime is the steam cavity. When the water in the test section is injected, the steam cavity mode persists. In the steam cavity mode, the steam injection rate is larger than the condensation rate through the interface because of the high water temperature. Then the pressure in the test section builds up to the steam generator pressure, and after that, the steam begins to displace the water in the test section during the water injection period. With respect to the condensation mode, the sparger and the natural circulation cause the reduction of the initiation time of the steam cavity by 1000sec and 600sec at 1.5bar and 4 bar, respectively. In these experiments, the chugging mode is not observed. The chugging mode is known to be observed at low steam mass flux and low water temperature.

Before the condensation mode enters the chugging mode, the water temperature increases beyond the chugging boundary.

Table 2.1: Tag list for the KARD-I instrument

Experiment parameters	Model no.	Measurement ranges	Units	Instrument uncertainty	Calculated parameters
S/G pressure	Foxboro E11AH	0 - 230	PSIS	1%	P-100100000
T/S pressure	OMEGA PX176-100S5V	0 - 100	PSIS	1%	P-160010000
Steam flow rate	OMEGA FV-505G	10 - 90	$kg/m^2$ sec	5%	mflowj-131000000
Injection flow rate	OMEGA FV-505L	0 - 8	GPM	3.6%	mflowj-161000000
Natural circulation flow rate	OMEGA FL-505L	0 - 25	GPM	3.6%	mflowj-325000000
T/S temperature	Type 92 RTD	-200 - 500	$^{\circ}C$	1%	tempf-160100000
Water level		70 - 85	cm	6%	cntrlvav 130

Table 2.2: Test matrix

test no	$P_{sg}$ (bar)	$T_s$ ( $^{\circ}C$ )	$T_w$ ( $^{\circ}C$ )	$\Delta T$ ( $^{\circ}C$ )	parameter effect
GI021	1.5	111.4	31	80	subcooling effect
GI022	1.5	111.4	61	50	
GI023	1.5	111.4	91	20	
GN021	1.5	111.4	31	80	natural circulation sparger
GS021	1.5	111.4	31	80	
PI041	4.0	144	31	113	high pressure effect
PN041	4.0	144	31	113	natural circulation sparger
PS041	4.0	144	31	113	



Table 2.3: Transition time between subsonic jet and steam cavity, and injection time

	Transition time (sec)	Injection time (sec)
GI021	1380	2250
GI022	432	1400
GI023	15	40
NI021	285	600
SP021	134	750
PI041	1064	1300
PN041	300	470
PS041	240	600

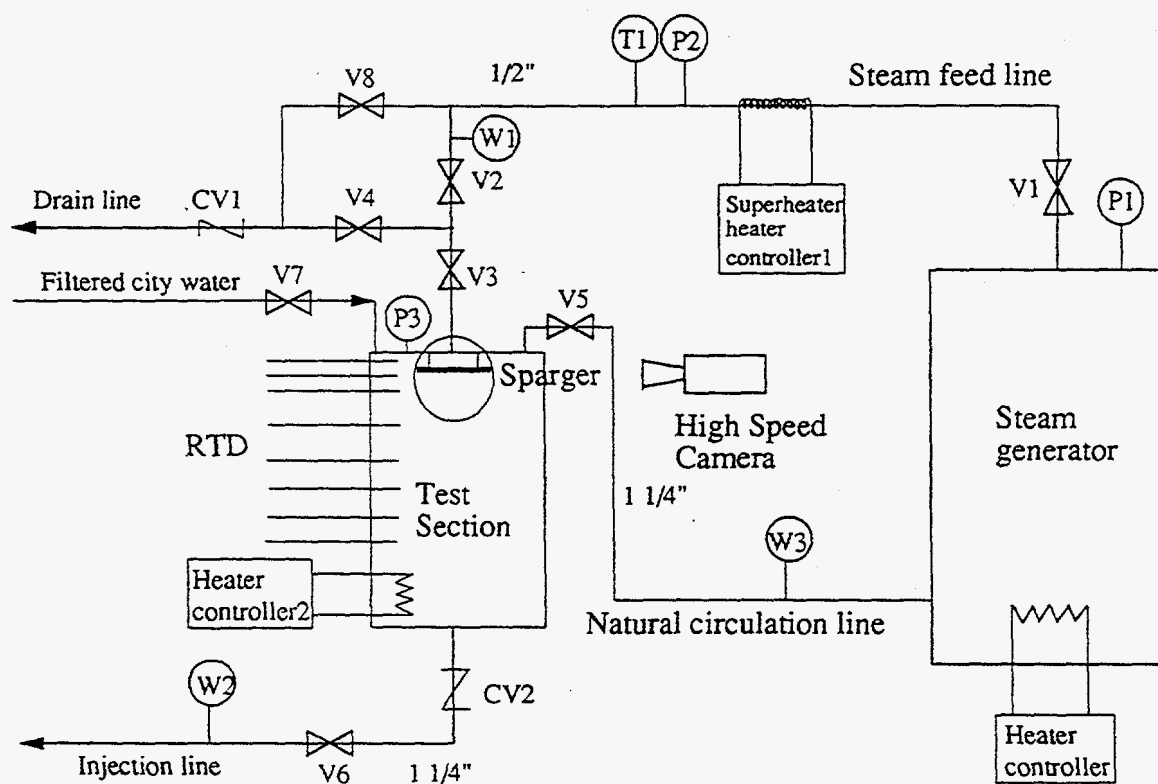

Figure 2.1: A systematic diagram of test facility

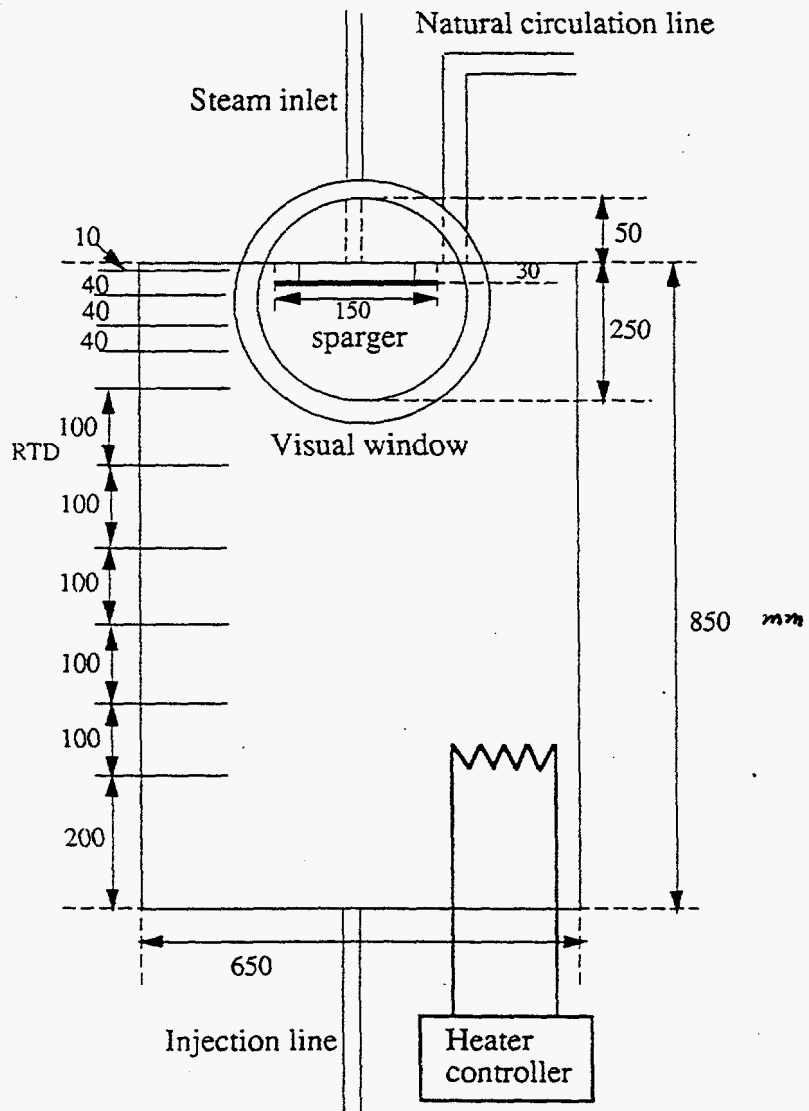

Figure 2.2: A systematic diagram of test section

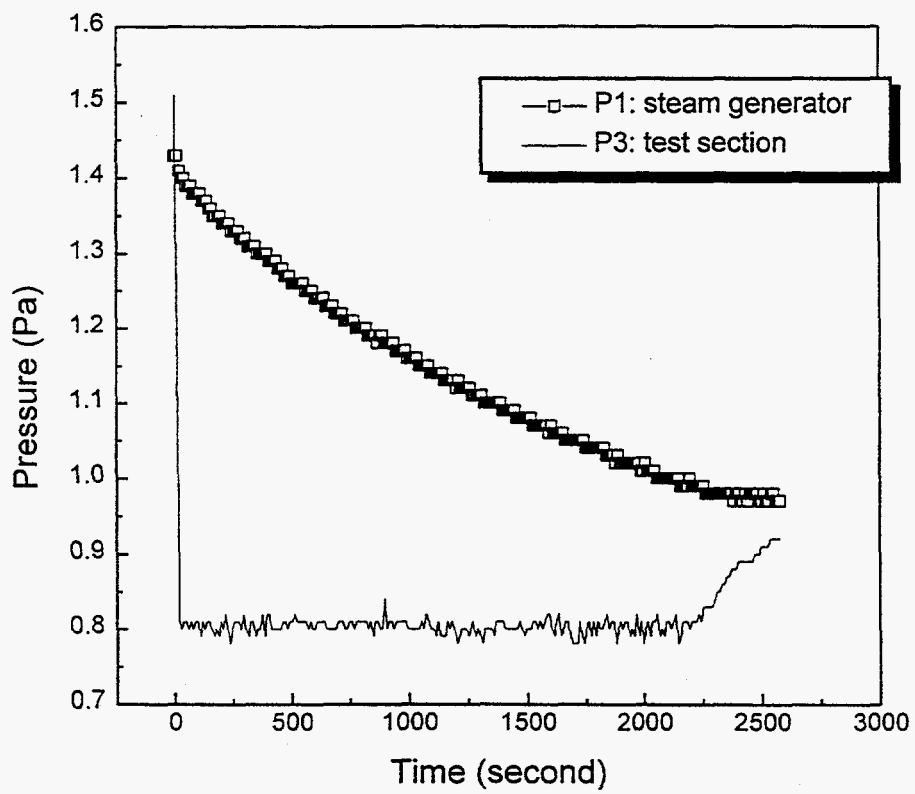

Figure 2.3: The pressure trend for test GI021

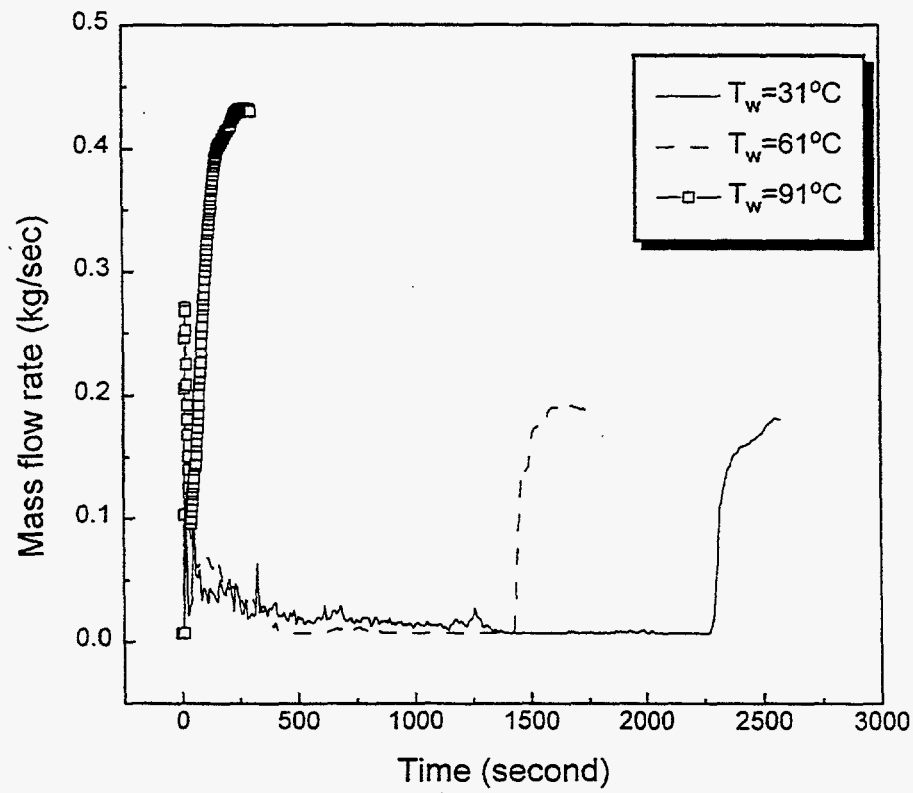

Figure 2.4: The effect of water subcooling on the injection flow rate for test GI021, GI022, and GI023

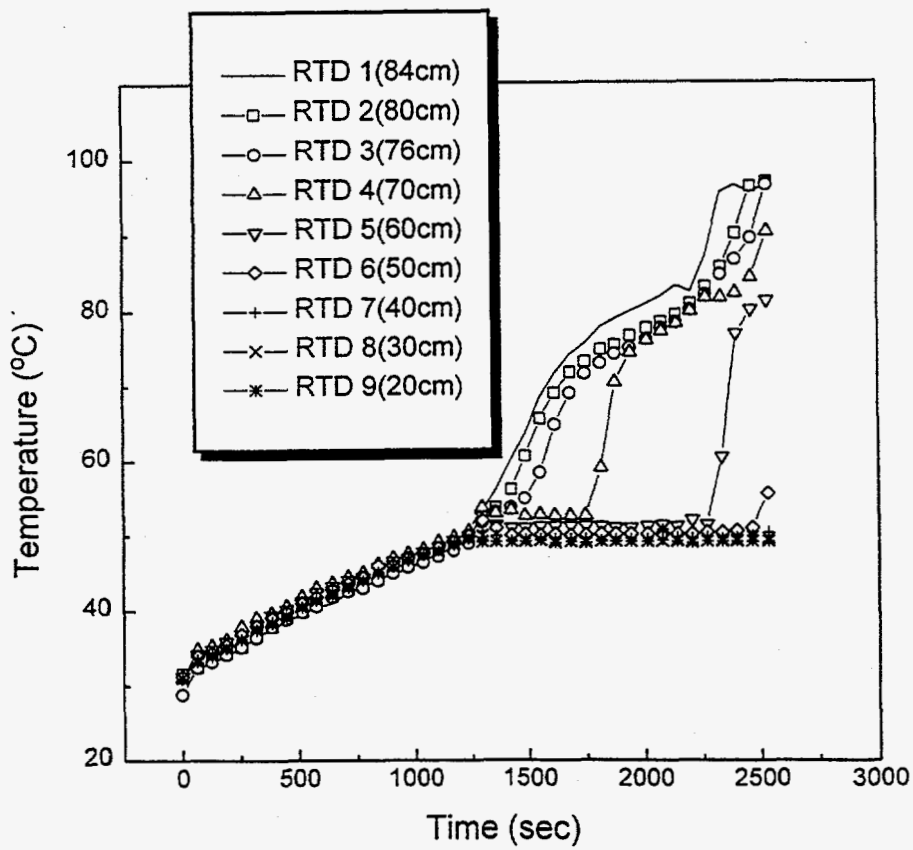

Figure 2.5: The temperature distribution of test section for test GI021

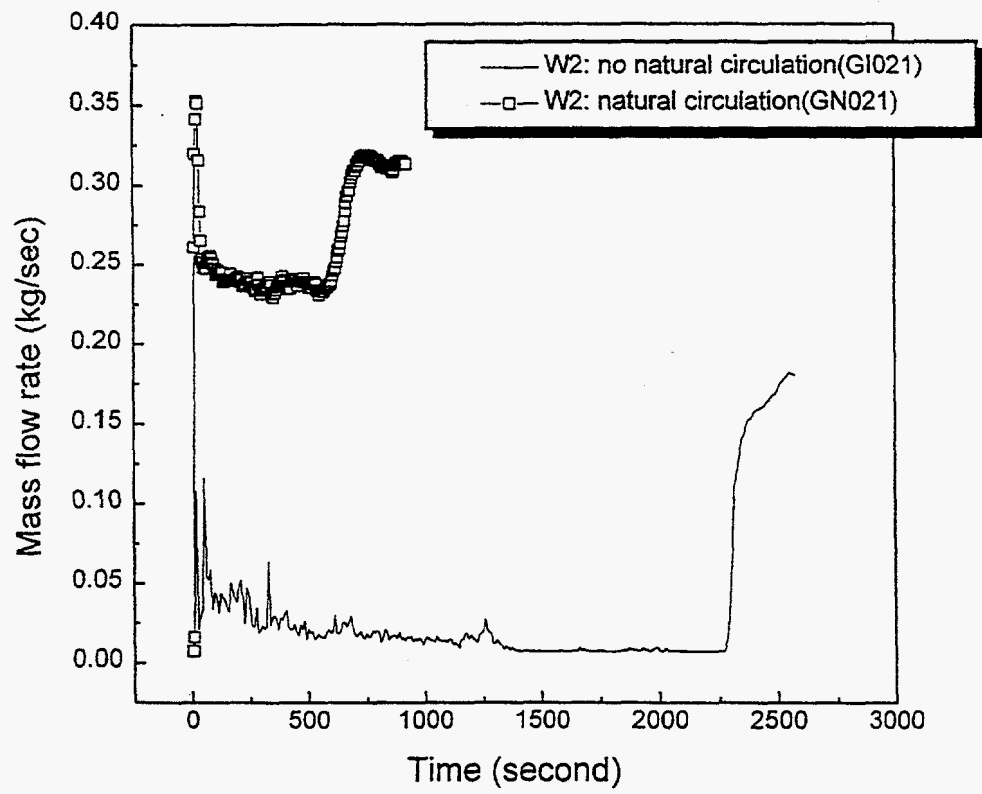

Figure 2.6: The effect of the natural circulation on the injection flow rate for test GI021 and GN021

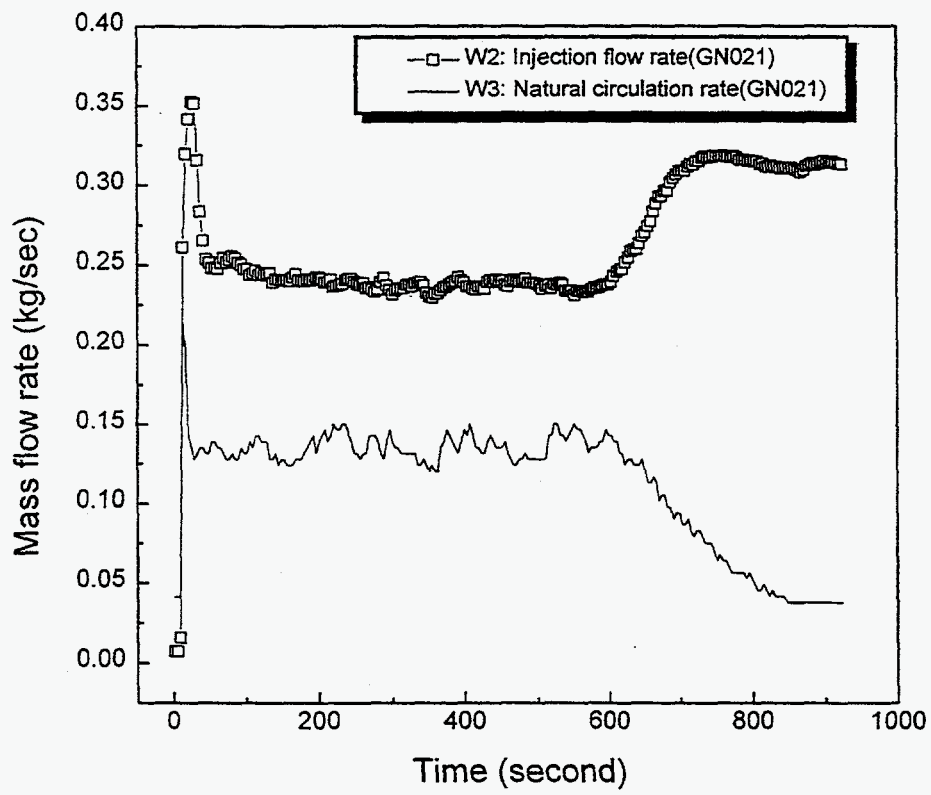

Figure 2.7: The comparison of the natural circulation flow with the injection flow rate for test GN021



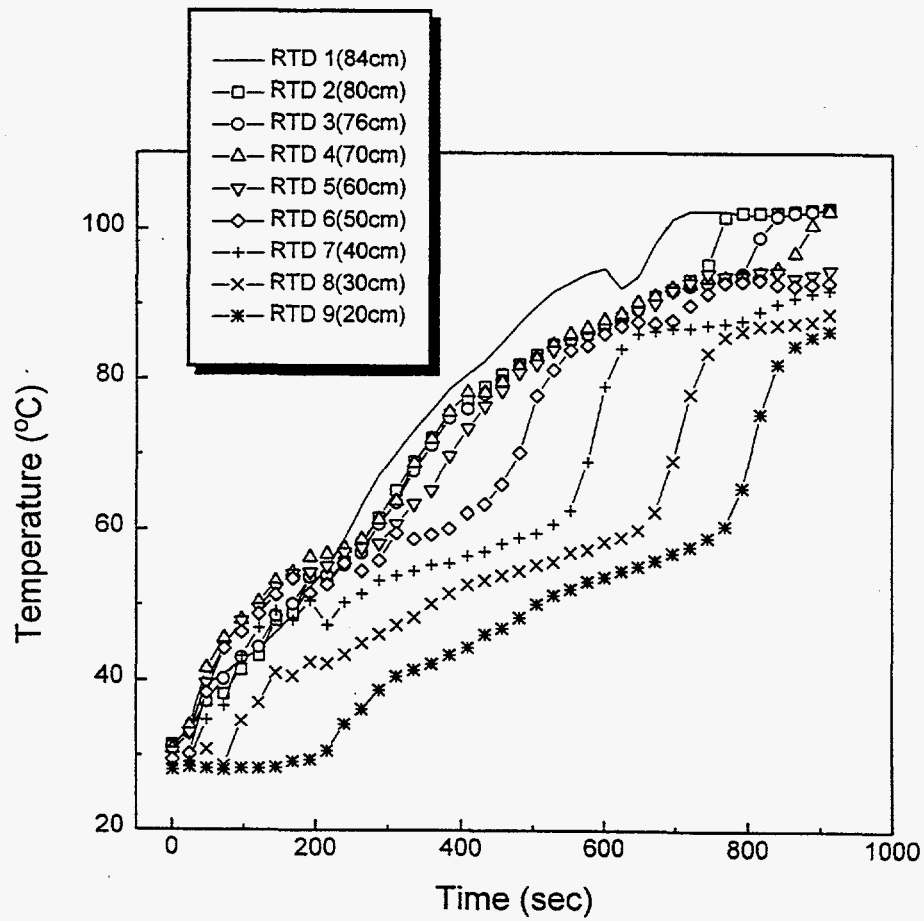

Figure 2.8: The temperature distribution of test section for test GN021

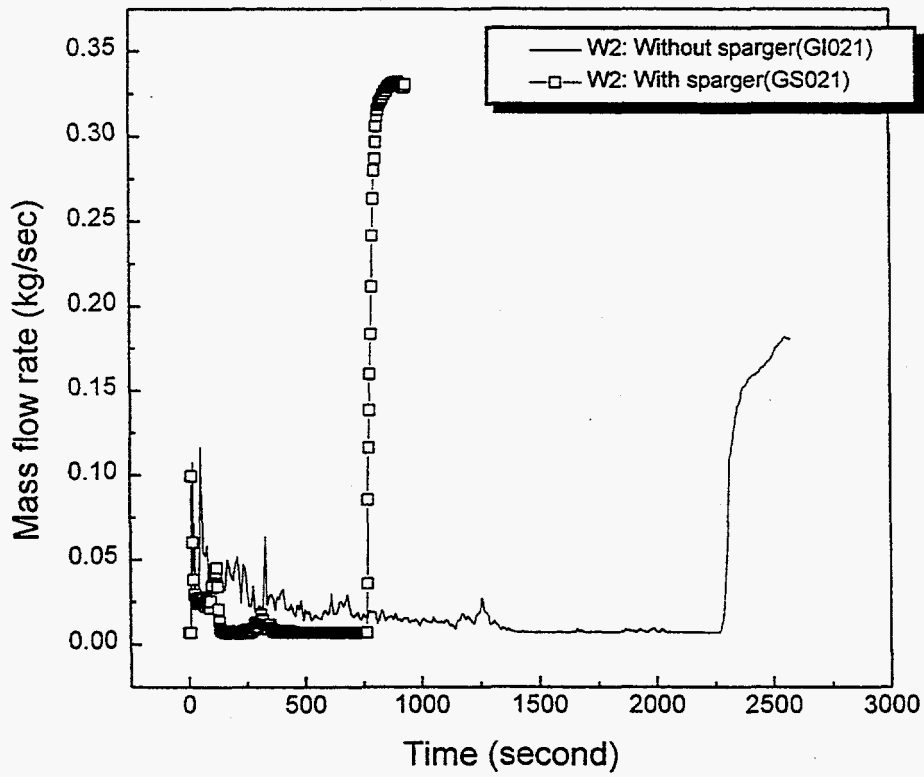

Figure 2.9: The effect of the sparger on the injection flow rate for test GI021 and GS021

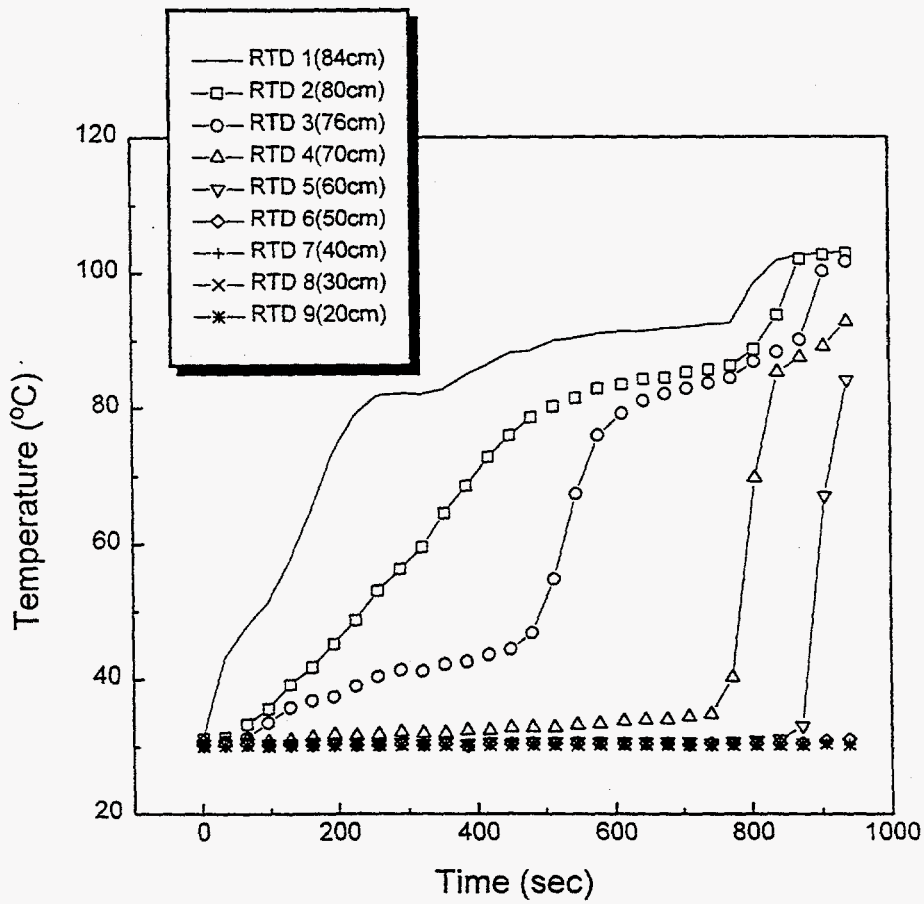

Figure 2.10: The temperature distribution of test section for test GS021

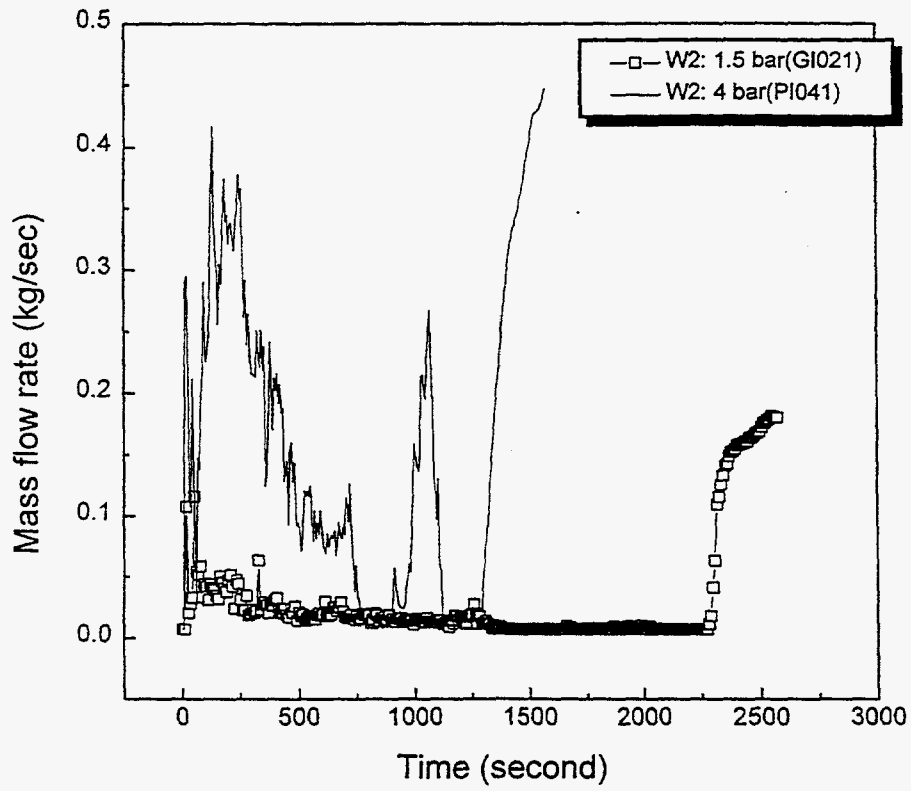

Figure 2.11: The effect of the high pressure on the injection flow rate for test GI021 and PI021

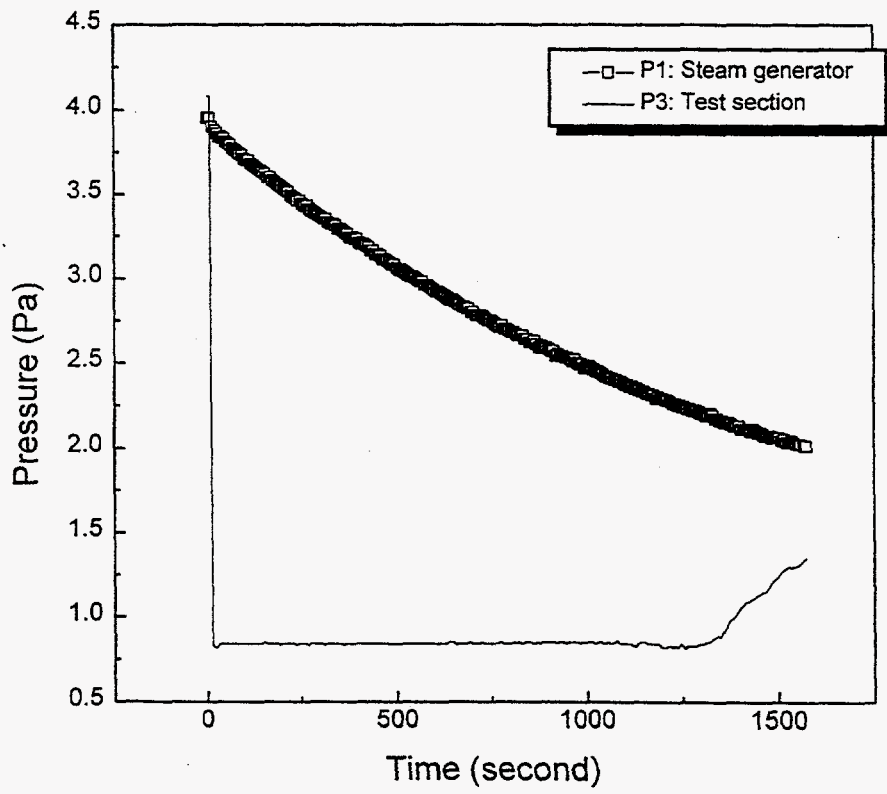

Figure 2.12: The pressure trend for test PI041

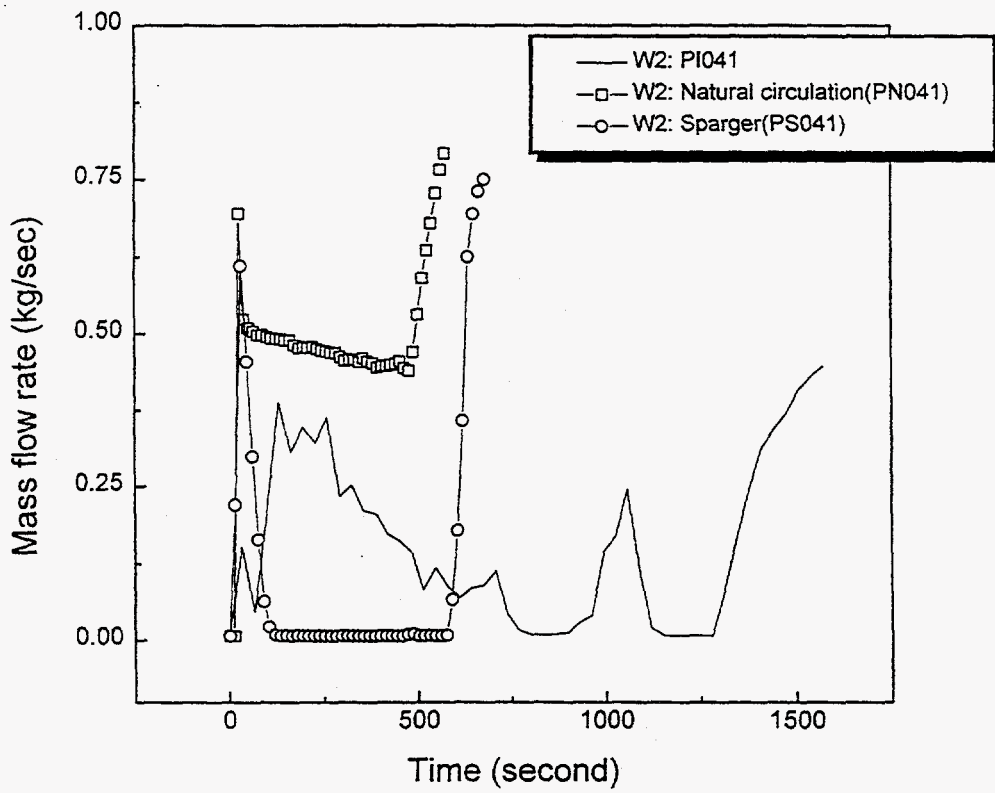

Figure 2.13: The injection flow rate at 4bar for test PI041, PN041, and PS041

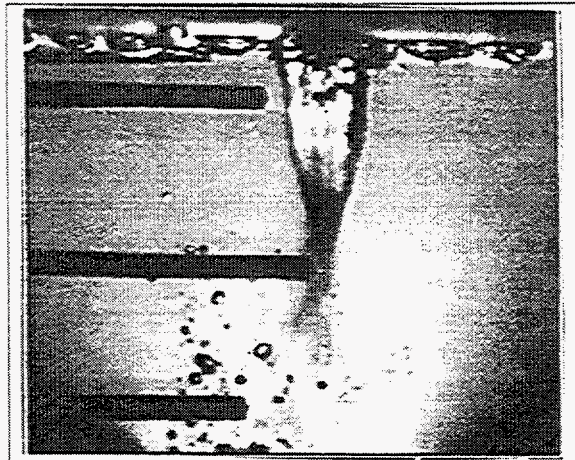

Figure 2.14: Sonic jet

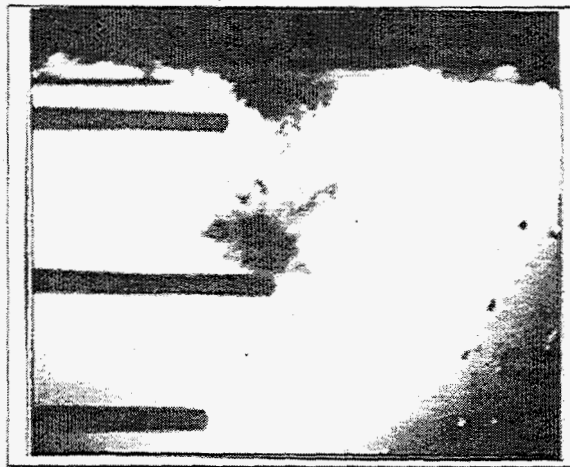

Figure 2.15: Subsonic jet



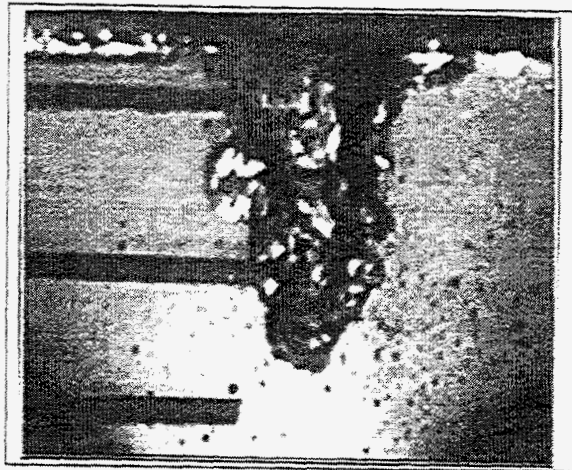

Figure 2.16: Steam cavity

## Chapter 3

# Assessment of RELAP5/MOD3.1

### 3.1 Description of code and modeling

The RELAP5 code has been developed as one of the best-estimate codes. The code is based on a non-homogeneous and non-equilibrium model for one dimensional, two-phase system that is solved by the semi-implicit numerical scheme to permit efficient evaluation of system transients. Recently, RELAP5/MOD3.1 code development program has been initiated to develop a code version suitable for the analysis of new safety system of passive advanced reactors like the CMT in the CNGR. However, there is no model in RELAP5/MOD3.1 that can deal with the direct contact condensation of steam in the pool like the CMT. To simulate the accidents of passive advanced reactors like the CNGR using RELAP5/MOD3.1, it is essential to develop the condensation regime and the model for the interfacial heat transfer coefficients of the direct contact condensation of steam in the pool. In this code assessment, RELAP5/MOD3.1 is mainly used, and standard RELAP5/MOD3.0 without any modification is used to compare with the results of the released version of RELAP5/MOD3.1.

RELAP5 nodalization used to simulate the gravity-driven injection experiment is represented in Figure 3.1. The model is based on 43 volumes connected

by 43 junctions and 3 heat structures for the electric heater. For other volumes except the electric heater, the heat structure are not installed because the power of the steam generator remains at 8KW to compensate the heat loss of the whole system during the test. The steam generator is modeled by pipe component (100) having 10 volumes. The heaters in the steam generator are modeled by heat structure having the power of 100 kw. The steam feed line between the test section and the steam generator is modeled as a single volume component (101), pipe components (110,120,130). The natural circulation line between the test section and the hot water of the steam generator is modeled as a branch component (310), pipe components (320, 330, 340). The injection valve is modeled as a servo valve component (161). At 10 sec, this valve is opened within 1 sec. The water injection line is modeled by pipe components (170,180). When the injection valve is opened, the water drains to the atmosphere which is model as a time dependent volume(200). If the large pressure drop occurs in the test section, there exists the possibility for air to enter the test section through the injection line. To prevent this, We installed a very large backward form loss coefficient as check valve in SJ171.

## **3.2 Analysis results and discussion**

### **3.2.1 Base case**

For base case calculations, tests GI021, GN021, PI041 and PN041 are simulated by RELAP5/MOD3.1 to determine whether or not it can describe the direct contact condensation occurring in the top of the test section. In addition, the results simulated by RELAP5 show different trends for different nodalization. The results show that the 1-node model of the test section predicts better the experimental data than the multi-node models [3]. In the base case calculations,

the 1-node model of the test section is used. The transient was initiated at 10 sec by opening the valve V101. The results of the simulation are compared with the experimental data in Figures 3.2 through 3.7. The following main characteristics are found:

- The calculated steam generator pressure is lower than that of the experimental data as shown in Figure 3.2. However, the code predicts the steam generator pressure transient for natural circulation (GN021 and PN041) relatively better than those for no natural circulation test (GI021 and PI021). These results show the code better represents the depressurization due to the steam condensation with natural circulation than that without natural circulation.
- As shown in Figure 3.3, in the case of no natural circulation (test GI021 and PI021), the calculated test section pressures overpredict the experimental data. However, the code underpredicts the experimental data of the natural circulation (test GN021 and PN021). Those results show that RELAP5/MOD3.1 overpredicts the pressure variations without natural circulation but underpredicts the pressure variation with natural circulation.
- As shown in Figure 3.4, the water temperature of the test section is overpredicted for the experiment with no natural circulation (GI021 and PI021). However, for the experiments with natural circulation, an underprediction is found. These results show that in the case of no natural circulation, RELAP5/MOD3.1 overpredicts the amount of the steam condensation without the hot water mixing, and in the case of natural circulation, it underpredicts the amount of the steam condensation with the hot water mixing. It is consistent with the results of the steam generator pressure.

- RELAP5/MOD3.1 underpredicts the experimental data of the steam flow rates due to the underpredictions of pressure difference between the steam generator and the test section. In the case of natural circulation(GN021) as shown in Figure 3.5, after 600sec the experimental steam flow rapidly decreases, but the predictions smoothly decrease because an increase of the water temperature due to the steam condensation and the hot water mixing make the pressure of the test section increase.
- As shown in Figure 3.6, RELAP5/MOD3.1 well predicts the time of the injection initiation, but it does not well predict the amount of the injection flow. In the case of test GN021, RELAP5/MOD3.1 shows high oscillation in the injection flow rate because the predictions of the test section pressure and the natural circulation flow rate show highly oscillatory behavior.
- The comparison of the water level between the experimental data and the calculated results shows that at 4 bar the code better predicts the experimental data than those at 1.5 bar as shown in Figure 3.7.

### 3.2.2 Sensitivity study

Sensitivity studies were performed with two RELAP5 code versions (MOD3.0 vs MOD3.1). The results of the sensitivity studies are compared with the experimental data as shown in Figures 3.8 through 3.12. The following main characteristics are found:

- As shown in Figure 3.8, MOD3.1 better predicts the experimental pressure than does MOD3. Figure 3.8(b) shows that MOD3.0 don't predict the pressure drop in the test section at all. Since the pressure difference between the steam generator and the test section predicted by MOD3.0 is smaller than that of MOD3.1, the steam flow rate and the test section water temperature

of MOD3.0 are lower than those of MOD3.1. These results show that the amount of the condensation in the test section predicted by MOD3.0 is less than that of MOD3.1.

- The comparison of the water level between the experimental data and the calculated results shows that although the predictions are in poor agreement with experimental data, MOD3.1 better predicts the experimental data than does MOD3.0. Both MOD3.0 and MOD3.1 predict the flow regime of the test section as vertical stratification. Both codes use the same interfacial heat transfer correlation for the vertical stratification regime. The reason MOD3.1 shows better agreement with the experimental data than does MOD3.0 is currently unknown. The flow regime observed in the experiment is the subsonic jet having the vertical cone shape. This is why the results of RELAP5/MOD3.1 is in poor agreement with the experimental data. For better prediction of the direct contact condensation in the CMT, it is essential that a new correlation for the interfacial heat transfer coefficient be developed.

### 3.2.3 Nodalization study

A nodalization study was performed to investigate the effect of the number of nodes in the test section (1 node, 2 nodes, 3 nodes). The results from the nodalization study are compared with the experimental data in Figures 3.13 through 3.17. The following main characteristics are found:

- The calculated pressures of the steam generator and the test section are in poor agreement with the experimental data for all nodalization schemes. These results show that the current models of RELAP5 can not produce sufficiently accurate predictions for the pressures of the steam generator

and the test section. The basic reason for such an inaccuracy is considered to results from the poor predictions of the amount of condensation by RELAP5/MOD3.1.

- As shown in Figure 3.14, the results of the 1-node model well agree with the experimental data until 1500sec. After 1500sec, the experimental tank temperature increases because of a decrease in the water level. It is shown that the larger the number of nodes, the higher the water temperature. Since RELAP5/MOD3.1 calculates the node average temperature, the component having the small volume reaches the saturation temperature faster than that of the large volume. In the 1-node model, a higher amount of condensation is predicted than in other models.
- The comparisons of the steam flow rate and the injection flow rate between the experimental data and the calculated results show that all the models underpredict the steam flow rate, but the 1-node and 2-node models have trends similar to the experimental data.
- Figure 3.17 shows the comparison of the water level between the different models and the experimental data. The results show that 1-node and 2-node models have trend similar to the experimental data. In the nodalization study, the results of the 1-node model are in better agreement with the experimental data than those of the other models.

### **3.2.4 Run statistics**

The primary computer used in the calculation is a SUN SPARC 10 with SunOS 4.1.3-KL operating system. The random access memory is 32 Mbyte. The calculation speed is 86.1 MIPS. The clock speed of CPU is 36 MHz.

Figure 3.18 shows the required CPU time and time step size with respect to the real transient time for the base case run. As shown in the figure, the slope of the CPU time becomes steep as the injection valve is opened, and the time step size is reduced down to 0.00075. Table 3.1 shows the grind time of each calculation. The grind time of GI021-MOD3.0 has the lowest value because the transient is mild due to a decrease in the interaction between steam and water resulting from a rapid decrease in the water level of the test section. The grind times of natural circulation experiments, such as GN021 and PN041, have larger values than the other calculations because of the oscillatory natural circulation flow and the coexistence of steam, cold water, and hot water. In the cases of GI021-3-node, GI021-MOD3.0 and GN021, the transients are terminated by the generation of thermodynamic property error. This error is an inherent weakness of RELAP5 which occurs when the steam exists in the subcooled water at the low pressure. In the case of test GI021, the grind time is as follows:

CPU time = 58333.9 sec

Number of time steps = 914360

Number of volumes = 28

Grind time = 2.2785



Table 3.1: Grind time

test	Real time (second)	CPU time (second)	Number of time step	Number of volume	Grind time	Termination status
GI021-1node	2600	58333.9	914360	28	2.2785	time control card
GI021-2node	2600	60692.2	908476	29	2.3037	time control card
GI021-3node	1950	56751.6	779543	30	2.4267	failure
GI021-MOD3.0	458.6	3402.32	72822	28	1.6686	failure
GN021	753	46887.7	449086	43	2.428	failure
PI041	1600	121665	2002225	28	2.1702	time control card
PN041	660	87906.9	847921	43	2.411	time control card

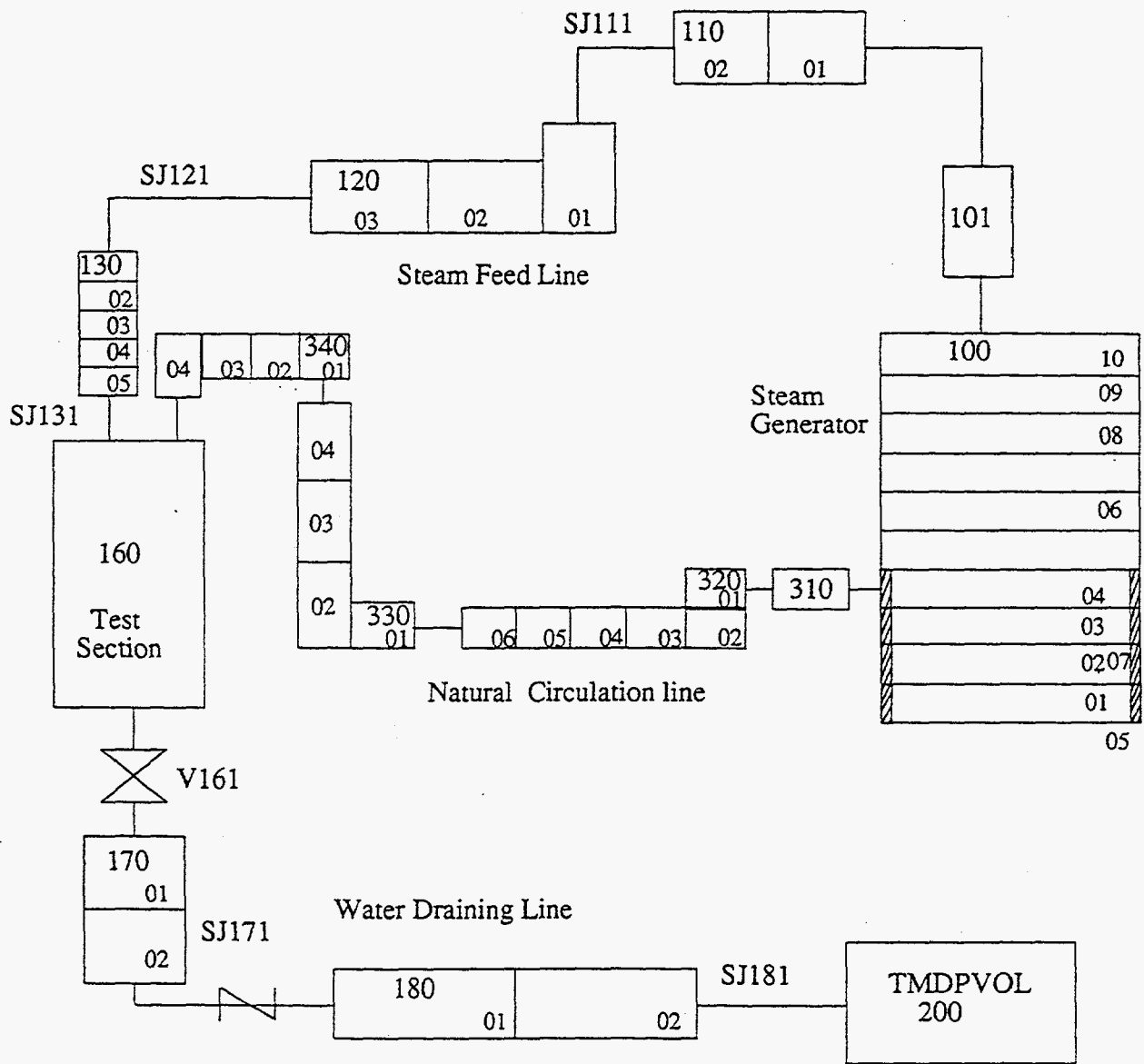

Figure 3.1: A systematic diagram of RELAP5 nodalization

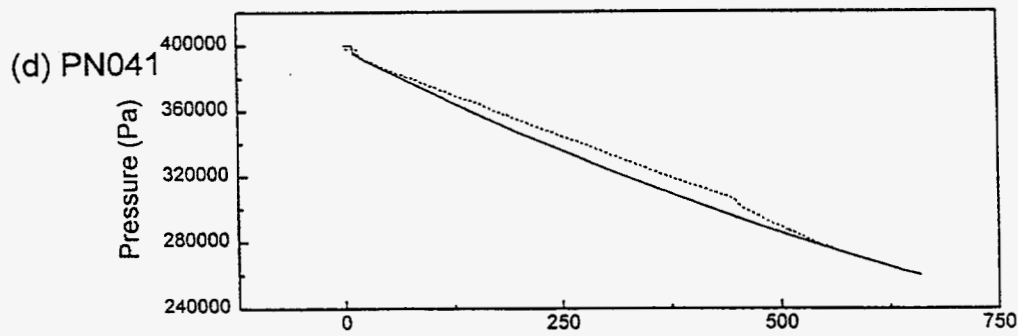
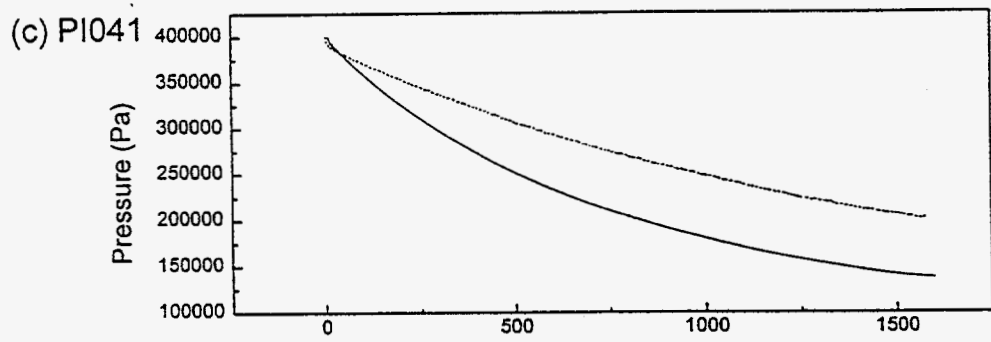
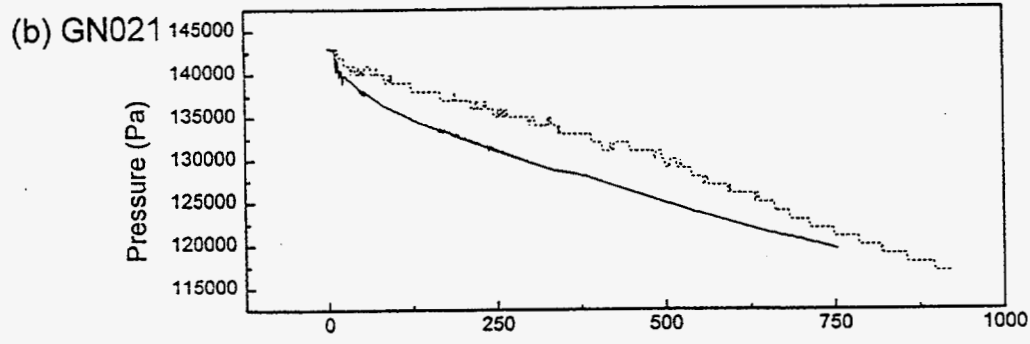
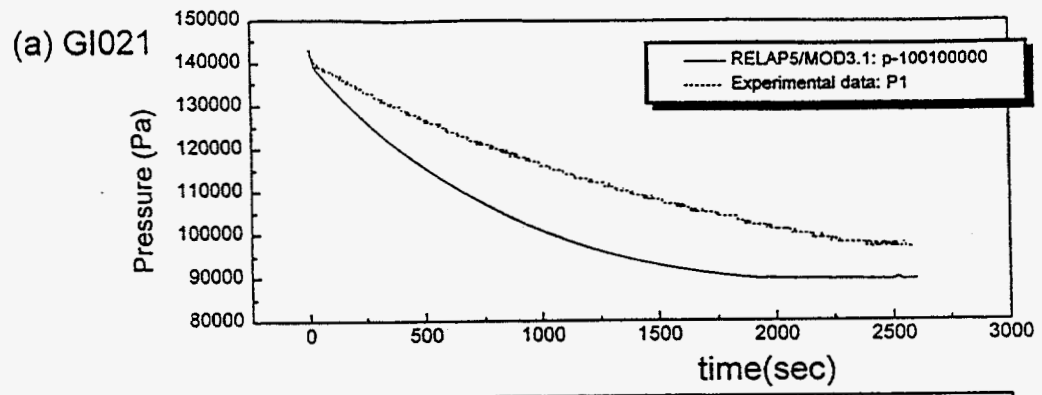

Figure 3.2: Comparison of the steam generator pressure between experiments and calculation

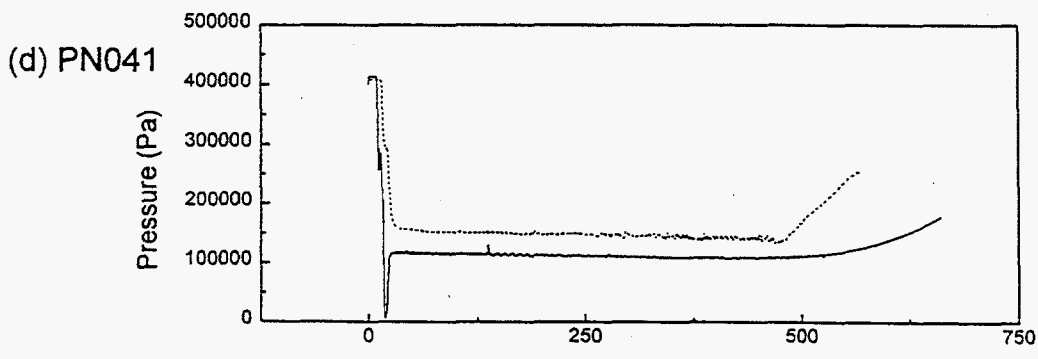
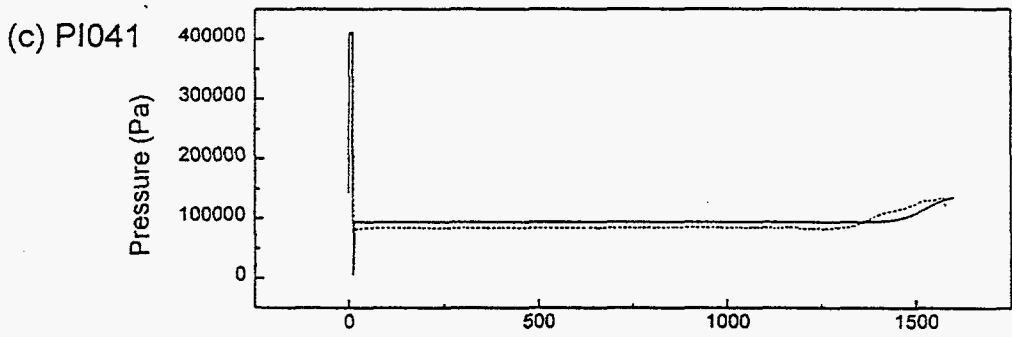
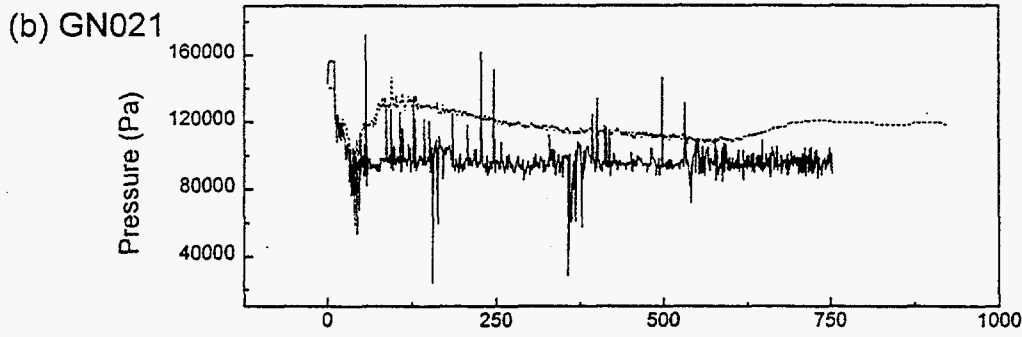
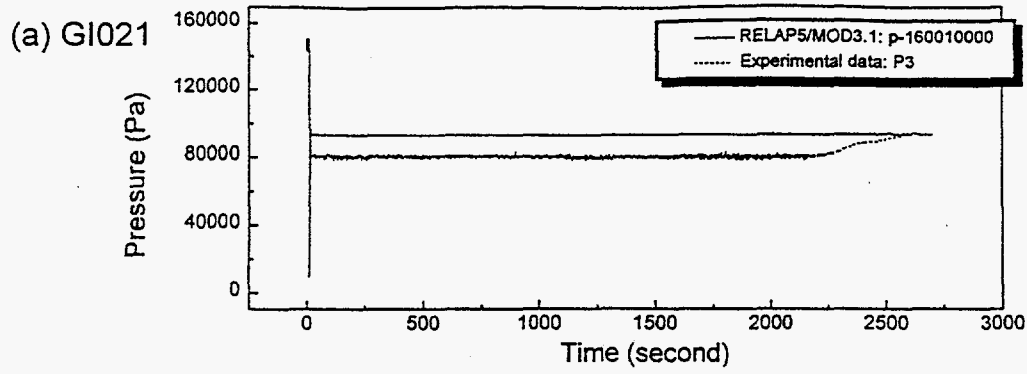
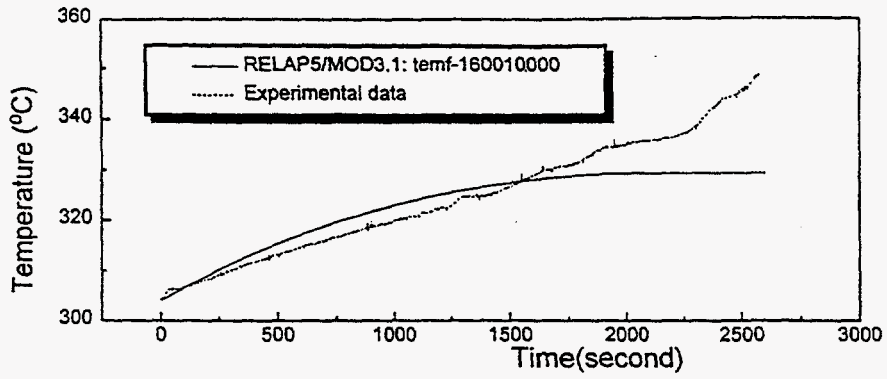
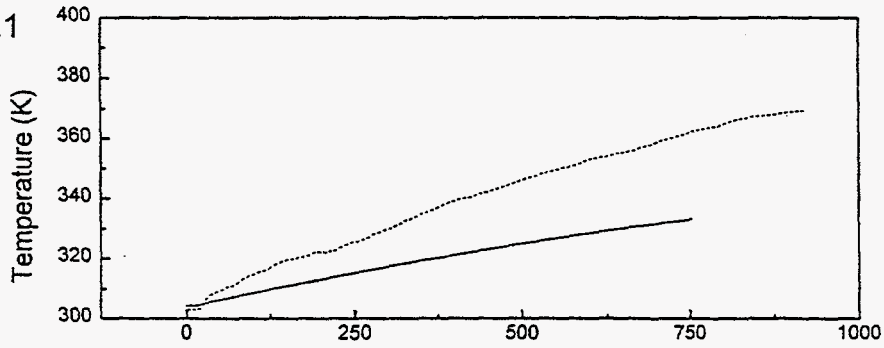

Figure 3.3: Comparison of the test section pressure between experiments and calculation

(a) GI021



(b) GN021



(c) PI041

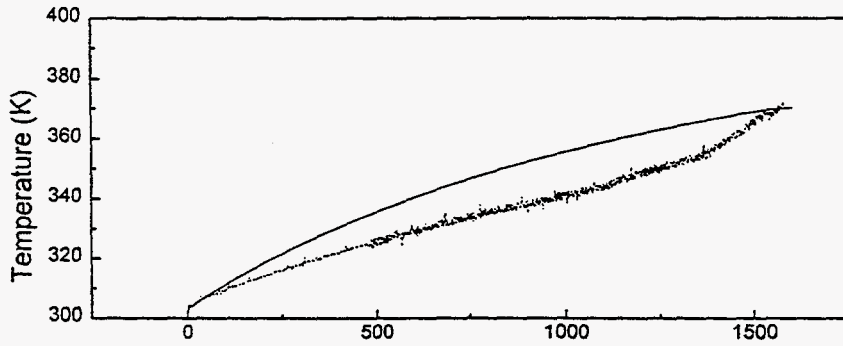

(d) PN041

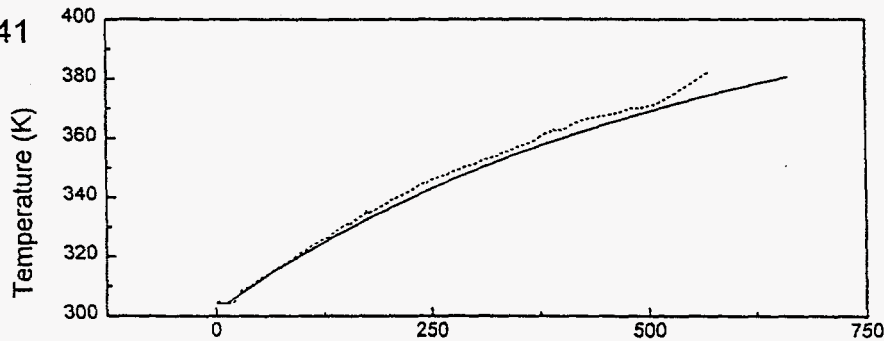

Figure 3.4: Comparison of the pool water temperature between experiments and calculation

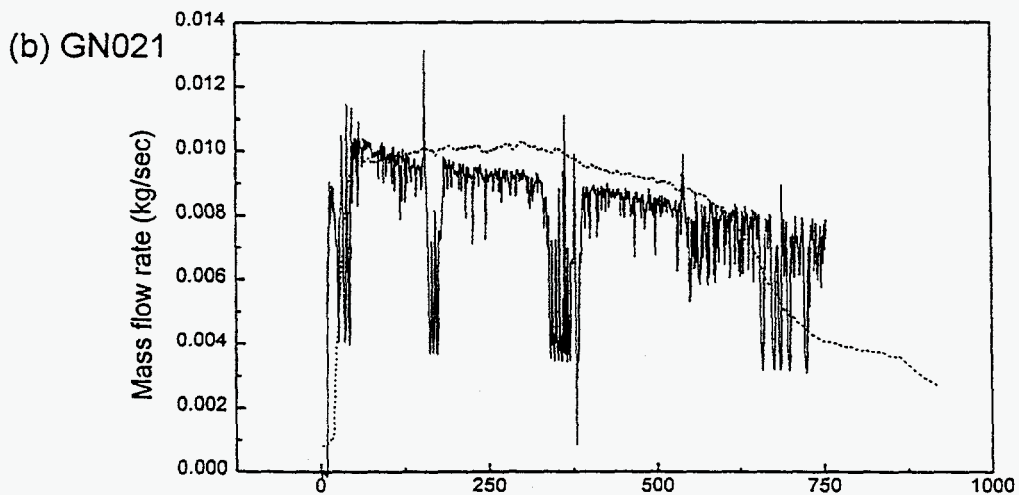
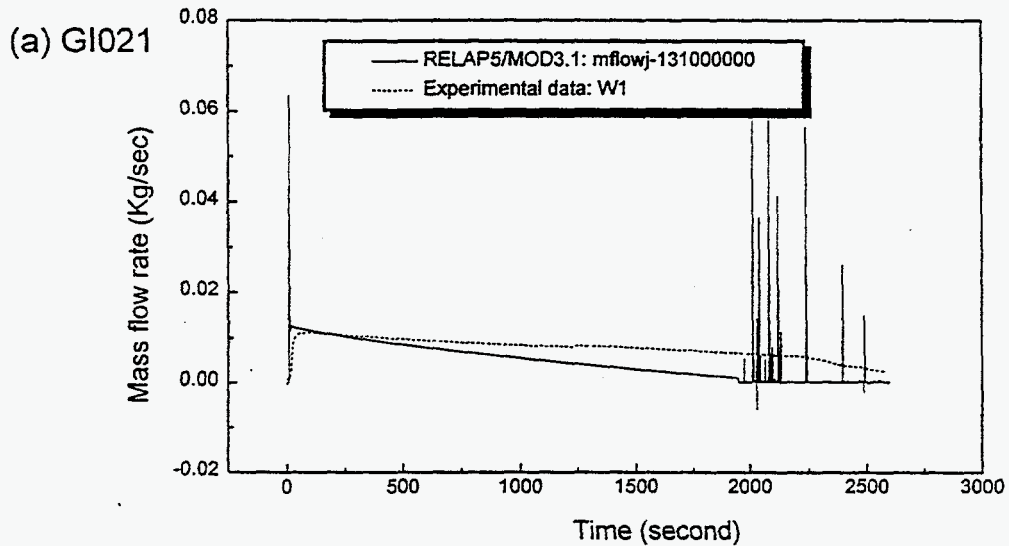

Figure 3.5: Comparison of the steam flow rate between experiments and calculation

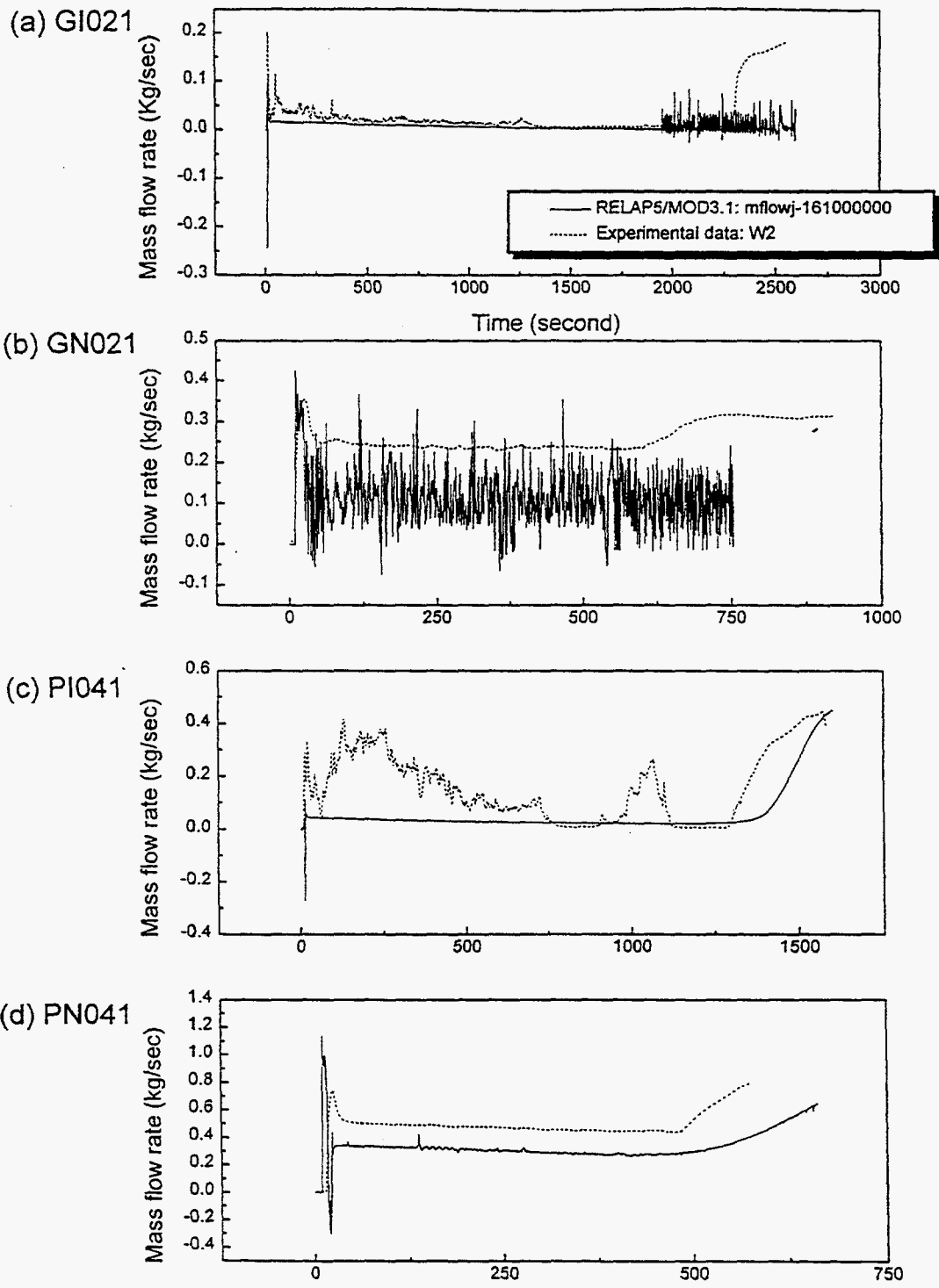

Figure 3.6: Comparison of the injection flow rate between experiments and calculation

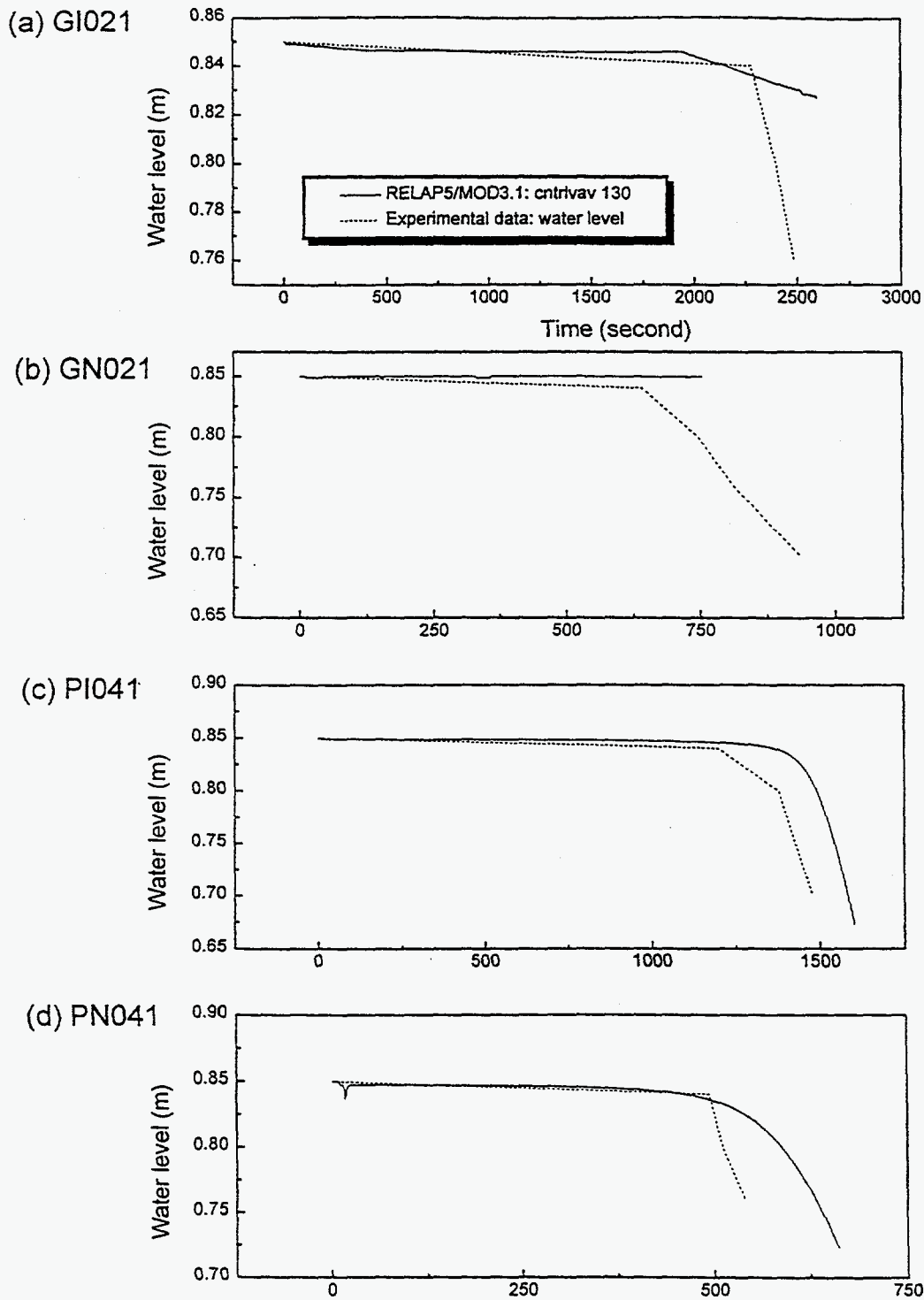
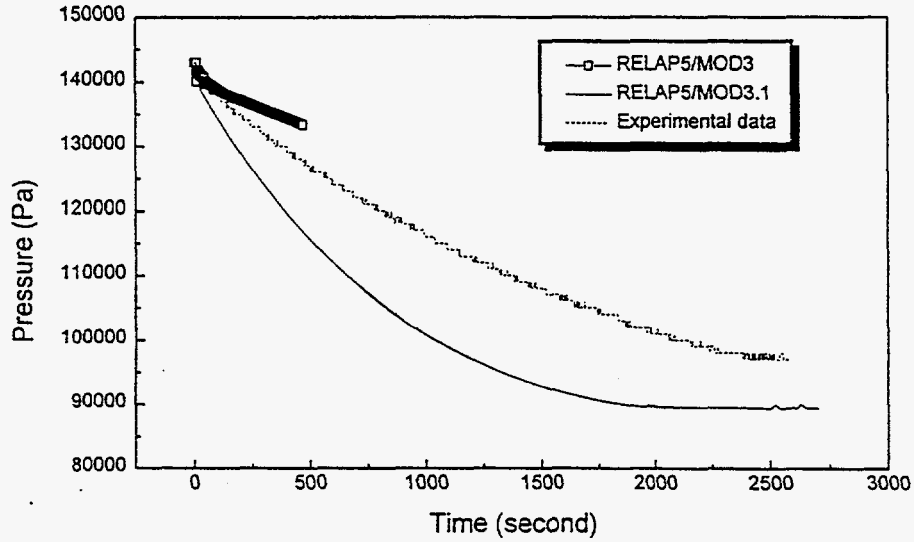

Figure 3.7: Comparison of the water level between experiments and calculation



(a) steam generator



(b) test section

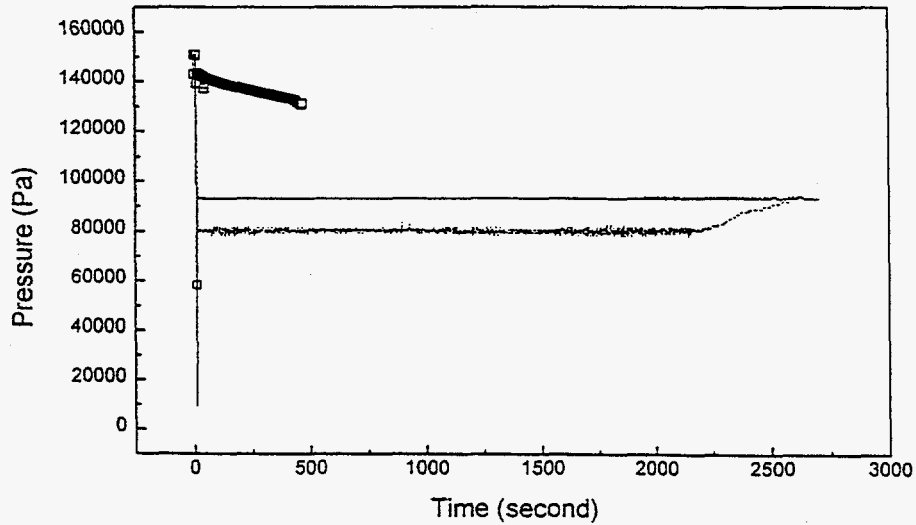

Figure 3.8: Comparison of the pressure of the steam generator and the test section between test GI021 and calculation(MOD3.0 vs MOD3.1)

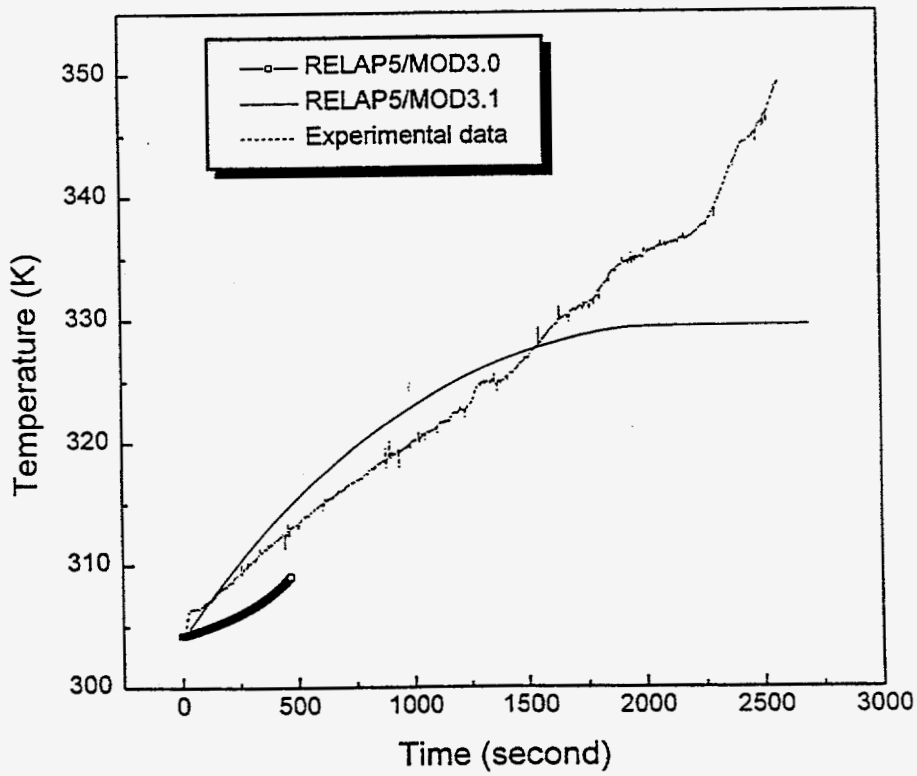

Figure 3.9: Comparison of the pool water temperature between test GI021 and calculation(MOD3.0 vs MOD3.1)

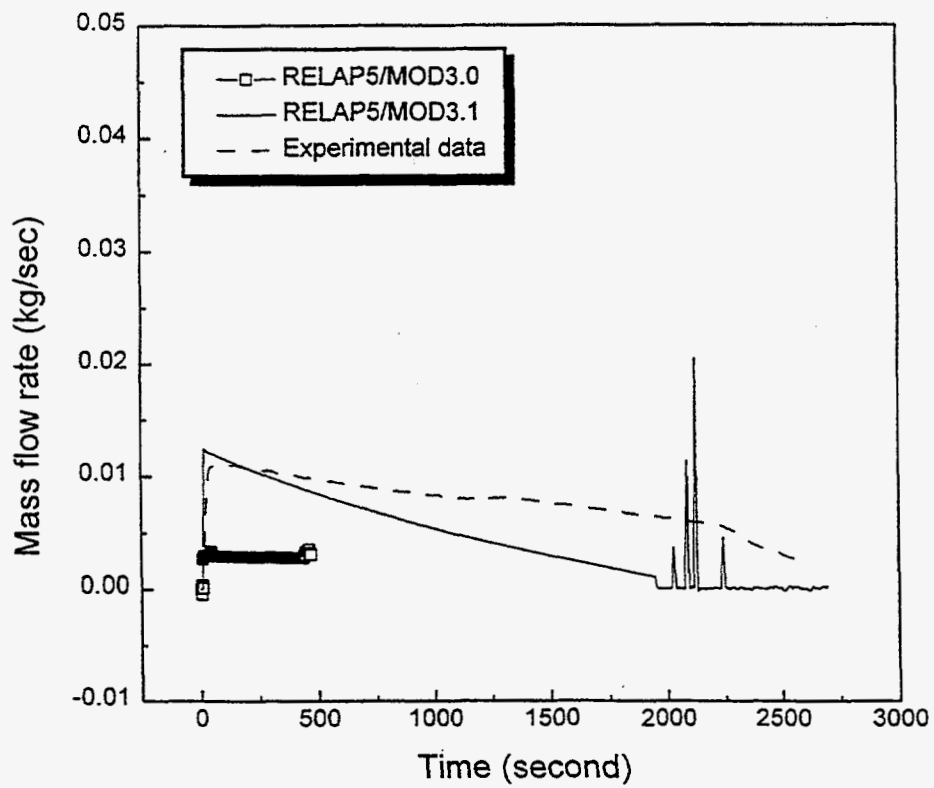

Figure 3.10: Comparison of the steam flow rate between test GI021 and calculation(MOD3.0 vs MOD3.1)

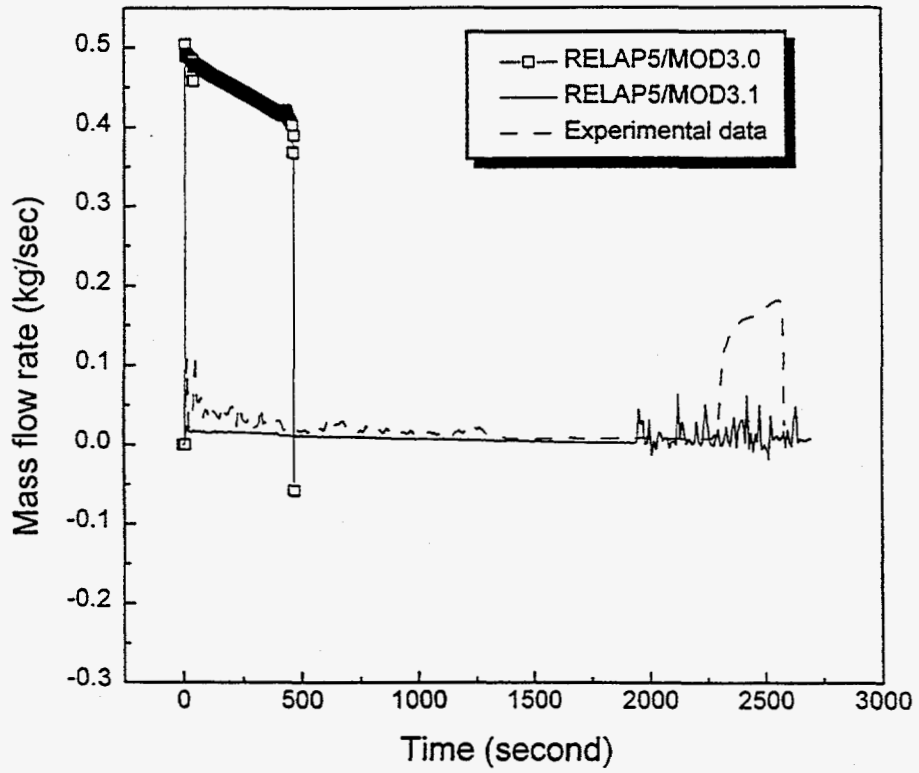

Figure 3.11: Comparison of the injection flow rate between test GI021 and calculation(MOD3.0 vs MOD3.1)

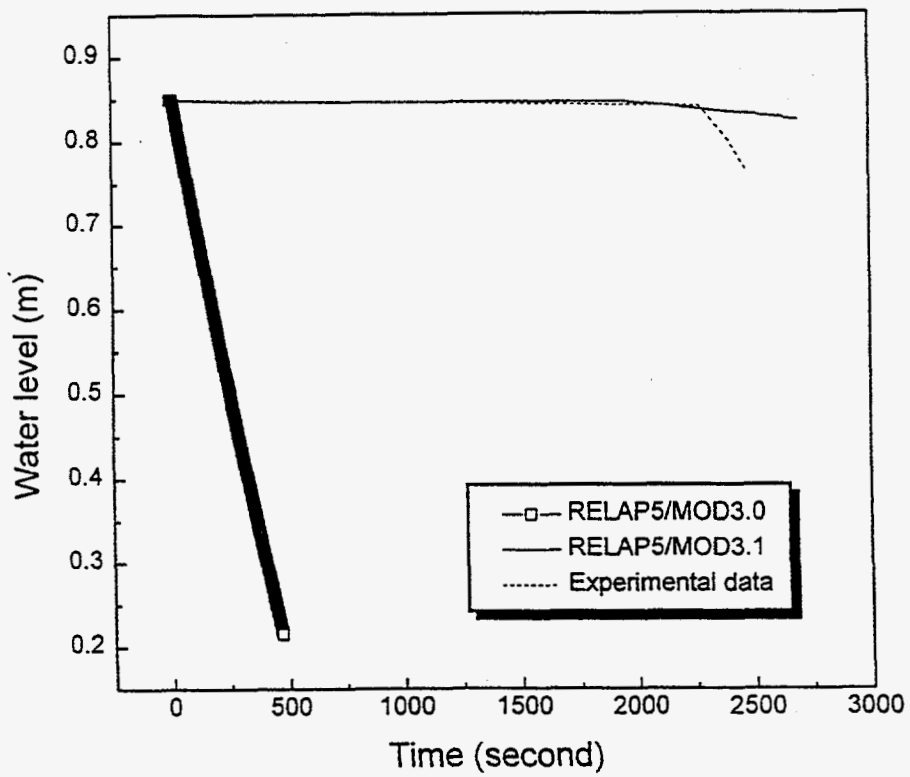

Figure 3.12: Comparison of the water level between test GI021 and calculation(MOD3.0 vs MOD3.1)

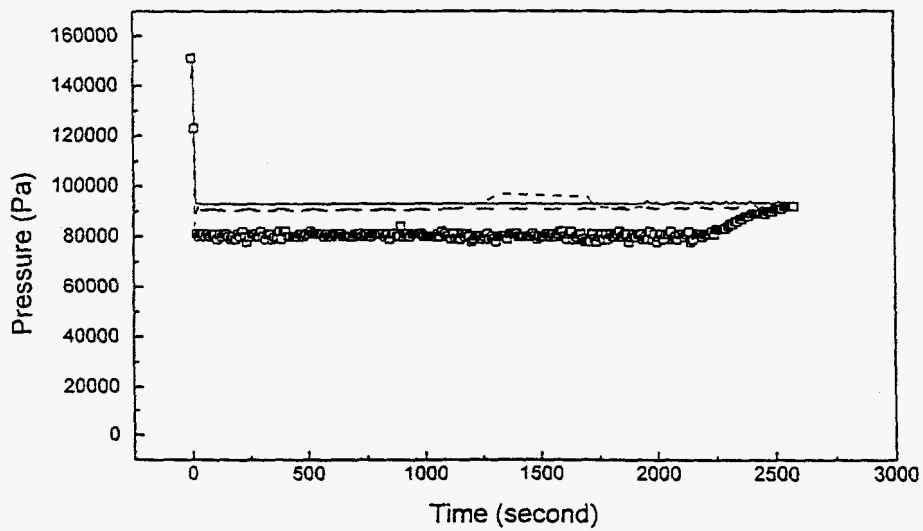
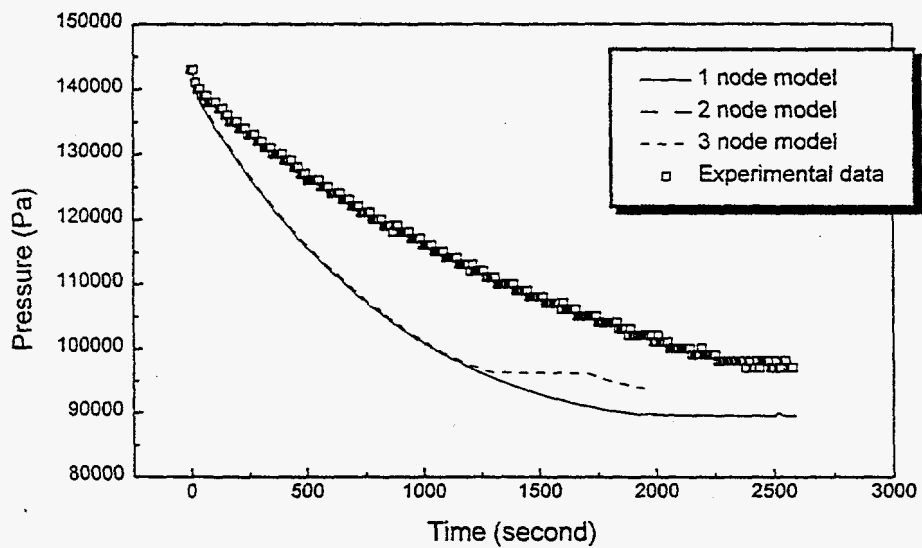

Figure 3.13: Comparison of the pressure of the steam generator and the test section between test GI021 and calculation(Nodalization study)

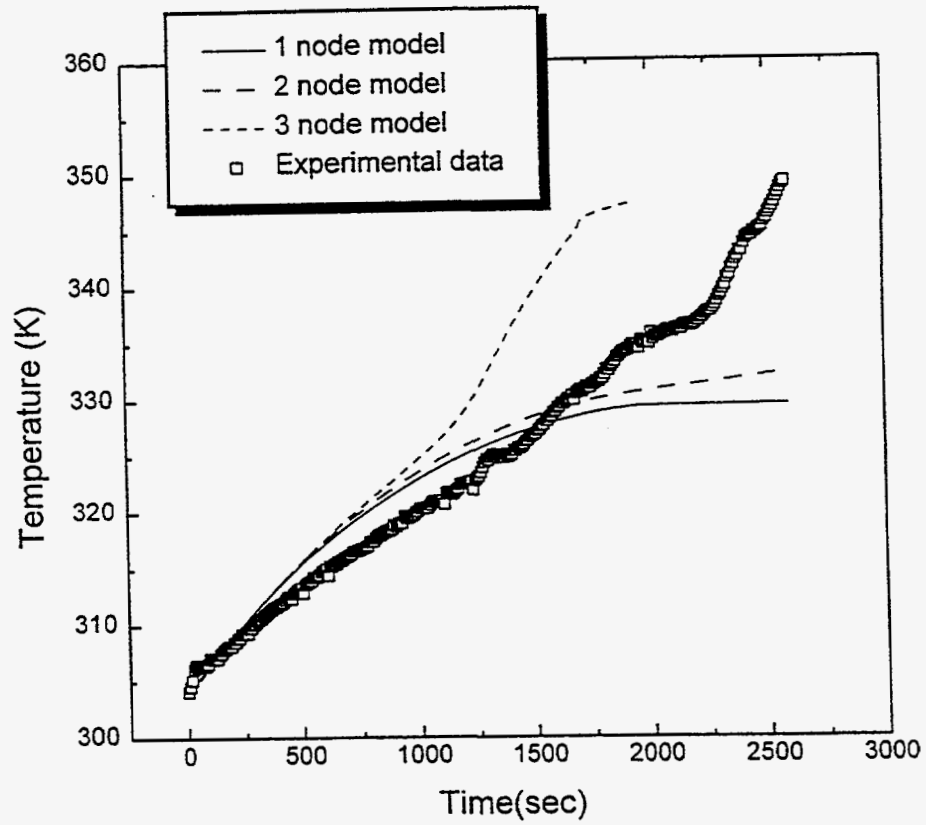

Figure 3.14: Comparison of the pool water temperature between test GI021 and calculation(Nodalization study)

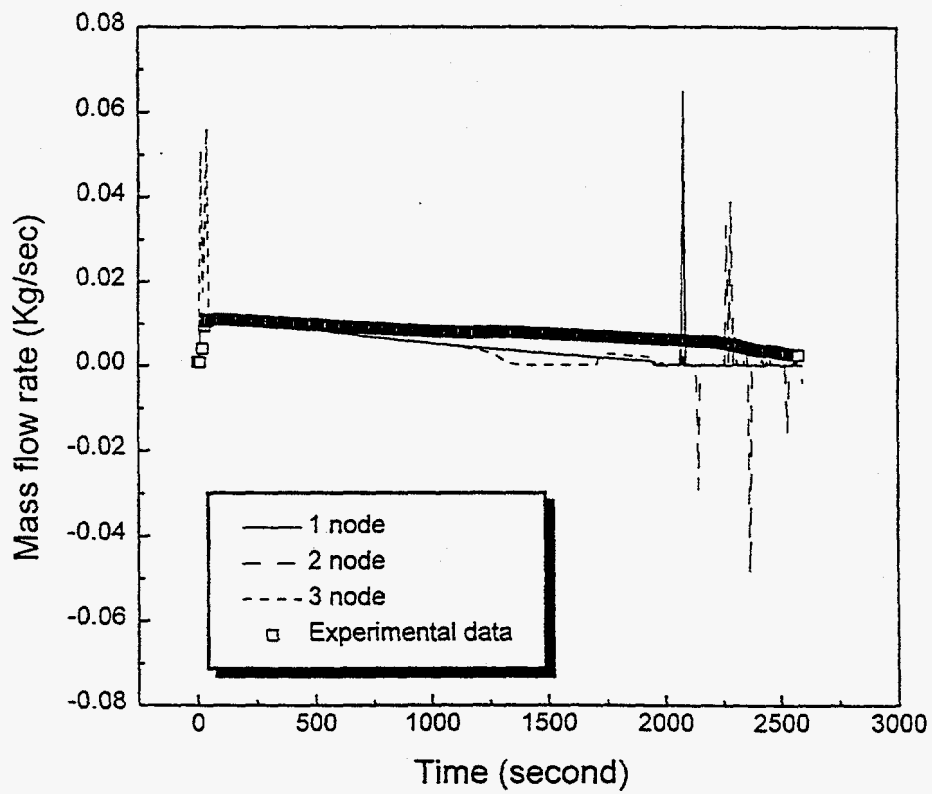

Figure 3.15: Comparison of the steam flow rate between test GI021 and calculation(Nodalization study)



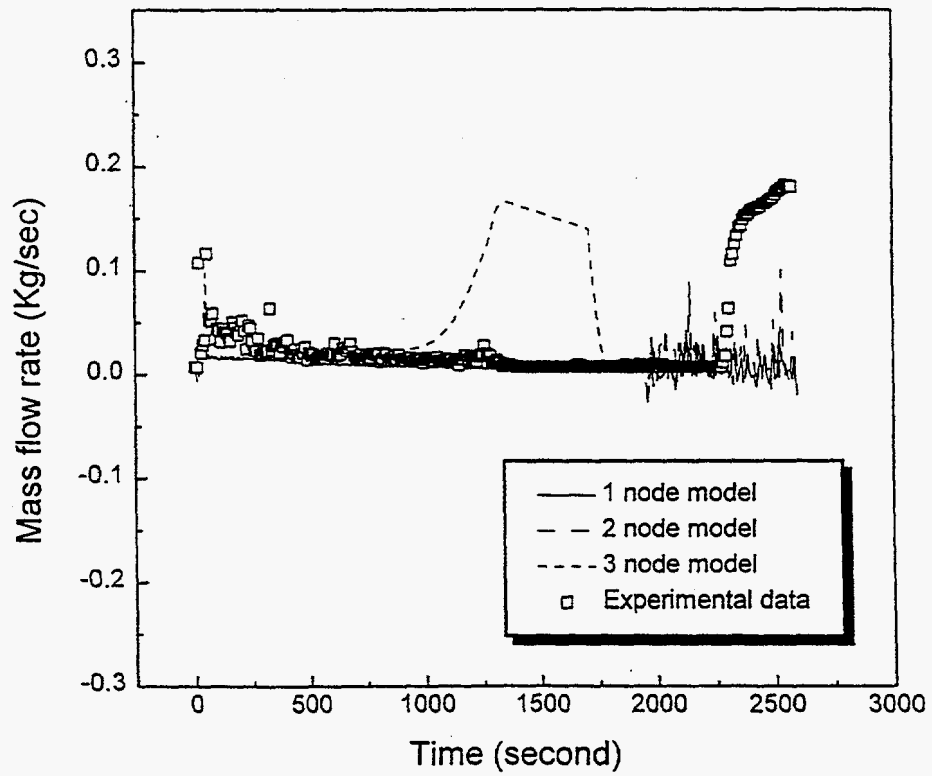

Figure 3.16: Comparison of the injection flow rate between test GI021 and calculation(Nodalization study)

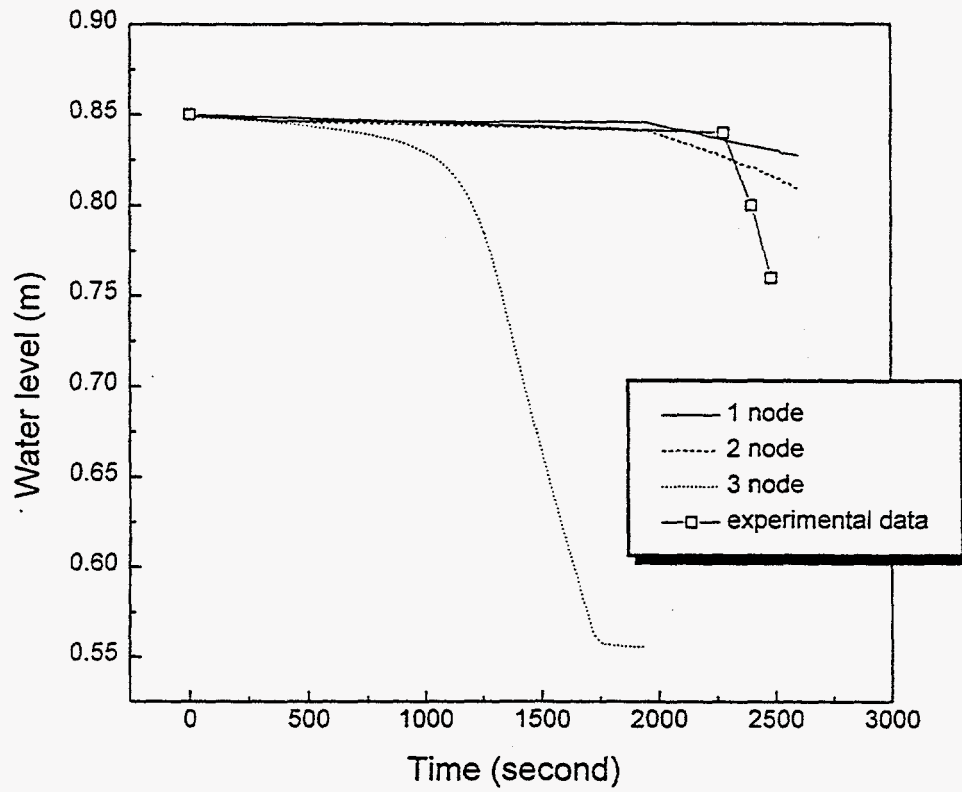

Figure 3.17: Comparison of the water level between test GI021 and calculation(Nodalization study)

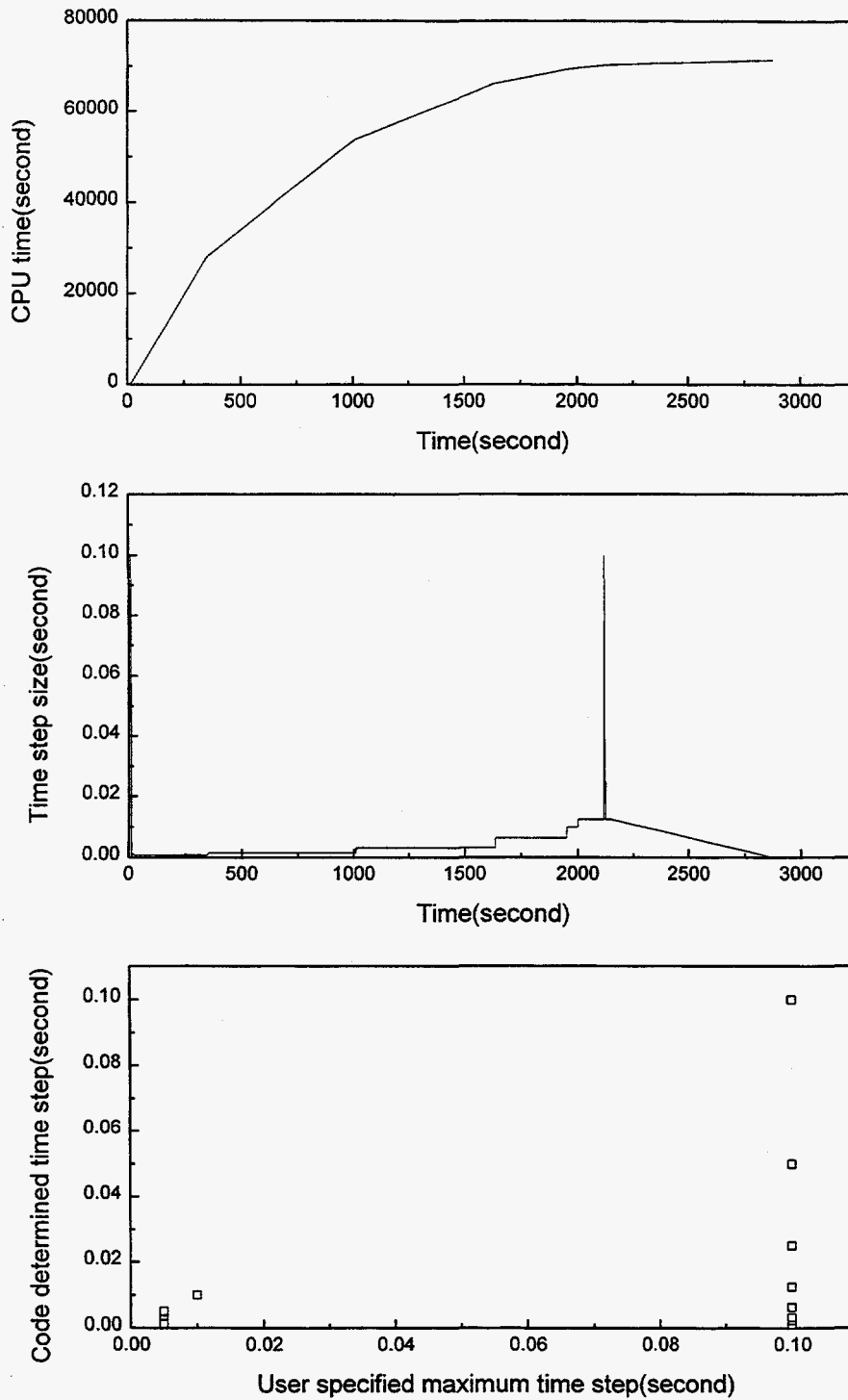

Figure 3.18: CPU time, time step size versus transient time and code determined time step versus user specified maximum time step

# Chapter 4

## Conclusions

The RELAP5/MOD3.1 was assessed using the small scale gravity injection experiment simulating direct contact condensation in the CMT of the PHPIS. For this assessment, a gravity injection experiment was conducted in the small scale test facility, KARD-I to identify the parameters governing the gravity injection and the major phenomena. To evaluate the code predictability of the direct contact condensation in the CMT, the calculated results were assessed and compared with the experimental data. From the present study, the following conclusions were obtained:

- The lower the water temperature, the longer the initiation time of injection is delayed. The results show that the sparger and the natural circulation from the hot water in the steam generator accelerate the injection of the test section. The condensation modes identified through the experiments are divided into three modes: sonic jet, subsonic jet, and steam cavity. The steam cavity is a unique mode of downward injection with a solid surface directly connected to the pipe exit not seen in other experiments.
- In the base case study, RELAP5/MOD3.1 predicts better the experimental water level at 4 bar than those at 1.5 bar. However, the calculated results

are not in good agreement with other experimental data, such as the pressures of the steam generator and the test section, the pool temperature, the flow rate of steam and injection, the test section water level.

- Sensitivity studies were performed with two RELAP5 code versions (MOD3.0 and MOD3.1). Although both codes do not predict precisely the experimental data, the results from RELAP5/MOD3.1 are in better agreement with the experimental data than those of RELAP5/MOD3.0. Both MOD3.0 and MOD3.1 identify the flow regime of the test section as vertical stratification, whereas the experimental flow regimes were sonic jet or subsonic jet according to steam flow.
- From a nodalization study of RELAP5/MOD3.1, the 1-node model shows better agreement with the experimental data than other multi-node models. However, considering the penetration depth of the jetting, the proper number of nodes of the CMT still remains to be determined.
- To reproduce direct contact condensation in the CMT with RELAP5/MOD3.1, it is necessary that new correlations for the interfacial heat transfer coefficients be developed. They should have a capability to capture the physical process of the direct contact condensation in the CMT.

# Bibliography

- [1] C. D. Flether, et al, RELAP5/MOD3 Code Manual, NUREG/CR-5535, EGG-2596, August, 1991.
- [2] T. Yonomoto, et al, Passive Safety Injection Experiment at the ROSA-V Large Scale Test Facility, NURETH-5, 1992.
- [3] Lee, Gyu Cheon, Effects of a Steam Jetting Mode on the Safety Injection of the Core Makeup Tank, KAIST, MS Thesis, 1994.
- [4] Y. Murao, et al, Outline of Emergency Coolant Injection System and Preliminary Test for Core Makeup Tank of JPSR, J. Atomic Energy Soc. Japan(in Japanese) Vol.24, No.5, 1982.
- [5] S. Fukuda, Pressure variation due to vapor condensation in liquid (II), J. AESJ, Vol.24, No.6, 1982.
- [6] C. K. Chan, et al, A Regime map for direct contact condensation, Int. J. Multiphase Flow Vol.8, No.1, pp.11-20, 1982.
- [7] I. Aya and H. Nariai, Boundaries between regimes of pressure oscillation induced by steam condensation in pressure suppression containment, Nucl. Eng. Des, Vol.99, pp.31-40, 1981.

- [8] Kuo-Shing Liang, et al, Experimental and Analytical Study of Direct Contact Condensation of Steam in Water, Nucl. Eng. Des, Vol.147, pp.425-435, 1994.
- [9] Frank, R. Cheslak, et al, Cavities formed in liquid surfaces by impinging gaseous jets, J. Fluid Mech, vol.36, pp.55-63, 1969.
- [10] M. Bocchiali, et al, SPES-2 AP600 integral system test inadvertent ADS opening and cold leg break transient, European Two-Phase Flow Meeting, 1994.
- [11] M. E. Simpson, et al, Hydrodynamics of a subsonic vapor jet in subcooled liquid, J. of Heat transfer, Vol.104, pp.271-278, 1982.

# Appendix A : Input Decks

## 1) GI021-1 node model

=RELAP5/MOD3.1 CMT 1 Nodes

\*test GI021 simulation

\*CMT node : 1 node

\*water valve: 10sec. opened

\*

\*job cards

100 new transnt

101 run

\*

110 air

\*

\*time step cards

201 10.0 1.0e-12 0.1 3 10 100 100

202 20.0 1.0e-12 0.005 3 200 1000 1000

203 1950. 1.0e-12 0.1 3 10 2500 2500

204 2000. 1.0e-12 0.01 3 100 5000 5000

205 2600. 1.0e-12 0.1 3 10 2500 2500

\*

\*minor editor cards

\*

\*

301 tempf 160010000 \* CMT - node 1

311 p 100100000

312 p 130050000

313 p 160010000

\*

\*

314 tempf 130020000

315 tempf 120010000

316 tempf 120020000

317 tempf 100050000

318 tempf 100010000

\*

319 voidg 160010000 \* CMT - node 1

322 voidg 130010000

323 voidg 130020000

324 voidg 120010000

325 voidg 110010000

326 voidg 100100000

327 voidg 100050000

\*

328 mflowj 130040000

329 mflowj 111000000

330 mflowj 121000000

331 mflowj 131000000

332 mflowj 161000000

334 mflowj 170010000

335 mflowj 171000000

336 mflowj 181000000

\*

\*

\*

355 vapgen 160010000 \* CMT - node 1

358 vapgen 170010000

359 vapgen 180010000

360 vapgen 110010000

361 vapgen 120010000

362 vapgen 130010000

363 vapgen 130020000

\*

364 floreg 110010000

365 floreg 120010000

366 floreg 120020000

367 floreg 130010000

368 floreg 130020000

369 floreg 160010000

372 floreg 170010000

373 floreg 180010000

\*

374 tempg 160010000

377 tempg 100100000

378 tempg 110010000

379 tempg 120010000

380 tempg 130010000

\*

383 sattemp 160010000

386 sattemp 100100000

387 sattemp 110010000

388 sattemp 120010000

389 sattemp 130010000

\*

392 cntrlvar 130 \* condensate level, frac.

\*

20800001 hif 160010000 \* CMT - node 1

20800002 hif 170010000

20800003 hif 180010000

20800004 hif 110010000

20800005 hif 120010000

20800006 hif 130010000

20800007 hif 130020000

\*

20800008 hig 160010000 \* CMT - node

1

20800009 hig 170010000

20800010 hig 180010000

20800011 hig 110010000

20800012 hig 120010000

20800013 hig 130010000



```

20800014 hig      130020000
*
*condensate level,fraction
*
20513000 con-lvl  sum  1.0  0.0  1
20513001 0.0    0.85  voidf 160010000
*
*****
*hydrodynamic data
*****
*
*component 100 : pipe ( steam generator )
*
1000000 sgtank  pipe
1000001 10
1000101 0.0      1
1000102 0.78540  9
1000103 0.0      10
1000301 0.205    10
1000401 0.02197  1
1000402 0.0      9
1000403 0.02197  10
1000601 90.0     10
1000801 0.000046 0.0 10
1001001 00000    10
1001101 000000   9
1001201 002    1.430e5 0.0 0.0 0.0 0.0 4
1001202 002    1.430e5 0.5 0.0 0.0 0.0 5
1001203 002    1.430e5 1.0 0.0 0.0 0.0 10
1001300 1
1001301 0.0    0.0 0.0 9
*
*branch 101 : branch (from S/G to horizontal pipe)
*
1010000 sg_up branch
1010001 2 1
1010101 0.00126 0.34 0. 0. 90. 0.34 0.000046
1010102 0.0 00000
1010200 002 1.4300e5 1.0
1011101 100100002 101010001 0.00126 0.49920
0.49920 000100
1011201 0.0 0.0 0.0
1012101 101010002 110010001 0.00126 0.57 0.57
000100
1012201 0.0 0.0 0.0
*
*component 110 : pipe (horizontal pipe above SG)
*
1100000 horzp1  pipe
1100001 3
1100101 0.00126 1

```

```

1100102 0.00049 3
*1100201 0.00049 2
1100301 0.22    1
1100302 0.90    3
1100401 0.0     3
1100601 0.0     3
1100801 0.000046 0.0 3
1100901 0.30469 0.30469 2
1101001 00000   3
1101101 000100  1
1101102 000000  2
1101201 002    1.4300e5 1.0 0.0 0.0 0.0 3
1101300 1
1101301 0.0    0.0 0.0 2
*
*junction 111 : single junction
*
1110000 vortexm  sngljun
1110101 110030002 120010001 0.0 0.75 0.75
000100
1110201 1 0.0 0.0 0.0
*
*component 120 : pipe (horizontal pipe above SG)
*
1200000 horzp2  pipe
1200001 3
1200101 0.00015 3
1200301 0.17    1
1200302 0.84    3
*1200501 90.0   1
*1200502 0.0    3
1200601 0.0     3
1200801 0.000046 0.0 3
1200901 0.75 0.75 1
1200902 0.0 0.0 2
1201001 00000   3
1201101 000000  2
1201201 002    1.4300e5 1.0 0.0 0.0 0.0 3
1201300 1
1201301 0.0    0.0 0.0 2
*
*junction 121 : single junction
*
1210000 pip1  sngljun
1210101 120030002 130010001 0.00015 0.75 0.75
000000
1210201 1 0.0 0.0 0.0
*
*component 130 : pipe (vertical pipe above CMT)
*

```

```

1300000 vertpip   pipe
1300001 5
1300101 0.00015  5
1300301 0.204    5
1300401 0.0      5
1300601 -90.0    5
1300801 0.000046 0.0  5
1301001 00000    5
1301101 000000   4
1301201 003     1.4300e5  304.0  0.0  0.0  0.0
5
*1301202 002     1.4300e5  0.66  0.0  0.0  0.0
4
*1301203 003     1.4300e5  304.  0.0  0.0  0.0
5
1301300 1
1301301 0.0  0.0  0.0  4 *
*
*junction 131 : junction from vertical pipe to the
cmt
*
1310000 cmtjun   sngljun
1310101 130050002  160010001  0.00015  0.99945
0.99945
1310102 000100
1310201 1  0.0  0.0  0.0
*
*
*volume 160 : single volume
*
1600000 cmt     snglvol
1600101 0.32170  0.85  0.0  0.0  -90.  -0.85
0.000046
1600102 0.0  00000
1600200 003  1.4300e5  304.27
*
*component 160 : pipe (cmt)
*
*1600000 cmttank pipe
*1600001 2
*1600101 0.32170  2
*1600301 0.425  1
*1600302 0.425  2
*1600401 0.0  2
*1600601 -90.0  2
*1600801 0.000046 0.0  2
*1601001 00000  2
*1601101 000000  1
*1601201 003  1.4300e5  304.0  0.0  0.0  0.0  2
*1601300 1
*1601301 0.0  0.0  0.0  1

```

```

*
*junction 161 : valve junction (valve below CMT)
*
1610000 dowvv   valve
1610101 160010002  170010001  0.00071  1.75
1.75  000100
1610201 1  0.0  0.0  0.0
1610300 srvvly
1610301 120
*
*component 170 : vertical pipe below CMT
*
1700000 belopip1 pipe
1700001 2
1700101 0.00071  1
1700102 0.00015  2
1700301 0.30     1
1700302 0.12     2
1700401 0.0      2
1700601 -90.0    2
1700801 0.000046 0.0  2
1700901 0.3750  0.3750  1
1701001 00000    2
1701101 000100   1
1701201 003     1.013e5  293.  0.0  0.0  0.0  1
1701202 003     1.013e5  293.  0.0  0.0  0.0  2
1701300 1
1701301 0.0  0.0  0.0  1
*
*
*junction 171 : junction between vertical and
horizontal pipes
*
1710000 beljun   sngljun
1710101 170020002  180010001  0.00015  0.75
1000.75
1710102 000100
1710201 1  0.0  0.0  0.0
*
*component 180 : horizontal pipe below CMT
*
1800000 belopip2 pipe
1800001 2
1800101 0.00015  2
1800301 1.0      2
1800401 0.0      2
1800601 0.0      2
1800801 0.000046 0.0  2
1801001 00000    2
1801101 000000   1

```

```

1801201 004 1.013e5 293. 0.0 0.0 0.0 1
1801202 004 1.013e5 293. 0.0 0.0 0.0 2
1801300 1
1801301 0.0 0.0 0.0 1
*
*junction 181 : junction to atmosphere
*
1810000 atmjun sngljun
1810101 180020002 200000000 0.00015 1.75
1.75
1810102 000100
1810201 1 0.0 0.0 0.0
*
*component 200 : atmosphere
*
2000000 air tmdpvol
2000101 0.0 100.0 1000.0 0.0 0.0.
2000102 0.0 0.0 00
2000200 004
2000201 0.0 1.013e5 293.0 0.0
*
**
*****
*valve control
*****
*
20512000 vlvarea function 1.0 0.0 0
20512001 time 0 003
*
*
*****
*valve table
*****
*
20200300 normarea
20200301 0.0 0.0
20200302 10. 0.0
20200303 10.01 1.0
20200306 10000. 1.0
*
*****
* heat structure input
*****
*
* cmt (1160)
*
*11600000 1 3 1 1 0.0

```

```

*11600100 0 2
*11600101 0.0225 2
*11600201 5 2
*11600301 0.0 2
*11600400 0
**11600401 288.0 3
*11600501 160010000 1 1 0 0.32170 1
*11600601 0 0 0 1 0.32170
1
*11600701 0 0.0 0.0 0.0 1
*11600801 0.0 10.0 10.0 10.0 10.0 0.0 0.0
1.0 1
*11600901 0.0 10.0 10.0 10.0 10.0 0.0 0.0
1.0 1
*
* cmt (1160-1)
*
*11601000 10 3 2 1 0.32
*11601100 0 2
*11601101 0.0025 2
*11601201 5 2
*11601301 0.0 2
**11601400 0
*11601401 288.0 3
*11601501 160010000 10000 1 1 0.085 10
*11601601 0 0 0 1 0.085 10
*11601701 0 0.0 0.0 0.0 10
*11601801 0.0 10.0 10.0 10.0 10.0 0.0 0.0
1.0 10
*11601901 0.0 10.0 10.0 10.0 10.0 0.0 0.0
1.0 10
*
* SG (1100)
*
*11000000 10 3 2 1 0.5
*11000100 0 2
*11000101 0.006 2
*11000201 5 2
*11000301 0.0 2
*11000400 0
**11000401 373.14 3
*11000501 100010000 10000 1 1 0.205 10
*11000601 0 0 0 1 0.205 10
*11000701 0 0.0 0.0 0.0 10
*11000801 0.0 10.0 10.0 10.0 10.0 0.0 0.0
1.0 10
*11000901 0.0 10.0 10.0 10.0 10.0 0.0 0.0
1.0 10
*
*

```

```

*****
* heat structure input for electric heater
*****
11005000 3 4 2 1 0.0
11005100 0 2
11005101 0.0015 2 0.001 3
11005201 11 2 5 3
11005301 1.0 2 0.0 3
11005400 0
11005401 384.4 4
11005501 0 0 0 1 36.0 3
11005601 100010000 10000 1 1 36.0 3
11005701 10212 1.0 0.0 0.0 3
11005901 0.0 10.0 10.0 10.0 10.0 0.0 0.0 1.0
3
*
* power table
*
*20221200 power 501 1. 100000.0
*20221201 -1. 0.0
*20221202 0. 1.0
*20221203 100. 1.0
*20221204 1000. 1.0
*
20100500 tbl/fctn 1 1 * s - steel
20101100 tbl/fctn 1 1* PZR heater (MgO)
*****
* MgO (011)
*****
* temp (k) volumetric heat capacity
(j/m3.k)
20101151 0.293e+03 .2600000e+07
20101152 0.450e+03 .2835000e+07
20101153 0.800e+03 .3402000e+07
20101154 1.120e+03 .3726000e+07
20101155 1.922038e+03 .3726000e+07
*
* temp (k) thermal conductivity (w/m.k)
*
20101101 0.29320e+03 81.40
20101102 1.27320e+03 100.47
20101102 1.9220389e+03 100.47 *
*
*****
* stainless steel (005) 18cr-8ni
*****
* temp (k) volumetric heat capacity
(j/m3.k)
20100551 .2742611e+03 .3831330e+07
*20100551 .2942611e+03 .3831330e+07

```

```

20100552 .3109278e+03 .3831330e+07
20100553 .3664834e+03 .3985580e+07
20100554 .4220389e+03 .4105300e+07
20100555 .4775945e+03 .4224090e+07
20100556 .5331500e+03 .4308800e+07
20100557 .5887056e+03 .4359790e+07
20100558 .6442611e+03 .4410320e+07
20100559 .8109278e+03 .4561910e+07
20100560 .9220389e+03 .4625250e+07
20100561 1.9220389e+03 .4625250e+07 *
*
* temp (k) thermal conductivity
(w/m.k)
20100501 .2732611e+03 .1489124e+02
20100502 .2942611e+03 .1489124e+02
20100503 .3109278e+03 .1505739e+02
20100504 .3664834e+03 .1609584e+02
20100505 .4220389e+03 .1696813e+02
20100506 .4775945e+03 .1800657e+02
20100507 .5331500e+03 .1885809e+02
20100508 .5887056e+03 .1956423e+02
20100509 .6442611e+03 .2041575e+02
20100510 .8109278e+03 .2297030e+02
20100511 .9220389e+03 .2423029e+02
20100512 1.9220389e+03 .2423029e+02 *
*
*****
* heater control
*****
*
20521200 heater constant 0.0
*
*
. end of file

```

2) GI021- 2 node model modification

\*component 160 : pipe (cmt)

\*

1600000 cmttank pipe  
1600001 2  
1600101 0.32170 2  
1600301 0.425 1  
1600302 0.425 2  
1600401 0.0 2  
1600601 -90.0 2  
1600801 0.000046 0.0 2  
1601001 00000 2  
1601101 000000 1  
1601201 003 1.4300e5 304.27 0.0 0.0 0.0 2  
1601300 1  
1601301 0.0 0.0 0.0 1

\*

1600101 0.32170 3  
1600301 0.2833 1  
1600302 0.2833 2  
1600303 0.2833 3  
1600401 0.0 3  
1600601 -90.0 3  
1600801 0.000046 0.0 3  
1601001 00000 3  
1601101 000000 2  
1601201 003 1.4300e5 304.27 0.0 0.0 0.0 3  
1601300 1  
1601301 0.0 0.0 0.0 2

\*

3) GI021- 3 node model modification

\*

\*component 160 : pipe (cmt)

\*

1600000 cmttank pipe  
1600001 3

4) GN021

=RELAP5/MOD3.1 CMT 1 Nodes

\* GN021 simulation

\* CMT node : 1 node

\* water valve: 10sec. opened

\* natural circulation line v/v : 10sec. opened

\*

\*job cards

100 new transnt

101 run

\*

110 air

\*

\*time step cards

201	10.0	1.0e-12	0.1	3	10	100	100
202	20.0	1.0e-12	0.005	3	100	500	500
203	40.0	1.0e-12	0.1	3	10	100	100
204	60.0	1.0e-12	0.005	3	100	500	500
205	1000.0	1.0e-12	0.1	3	10	2500	2500

\*

\*minor editor cards

\*

\*

301 tempf 160010000 \* CMT - node 1

311 p 100100000

312 p 130050000

313 p 160010000

\*

\*

314 tempf 130020000

315 tempf 120010000

316 tempf 120020000

317 tempf 100050000

318 tempf 100010000

319 tempf 320010000

\*

320 voidg 160010000 \* CMT - node 1

321 voidg 130010000

322 voidg 130020000

323 voidg 120010000

324 voidg 110010000

325 voidg 100100000

326 voidg 100050000

\*

328 mflowj 130040000

329 mflowj 111000000

330 mflowj 121000000

331 mflowj 131000000

332 mflowj 161000000

334 mflowj 170010000

335 mflowj 171000000

336 mflowj 181000000

337 mflowj 310020000

338 mflowj 325000000

339 mflowj 345000000

\*

\*

\*

355 vapgen 160010000

358 vapgen 170010000

359 vapgen 180010000

360 vapgen 110010000

361 vapgen 120010000

362 vapgen 130010000

363 vapgen 130020000

\*

364 floreg 110010000

365 floreg 120010000

366 floreg 120020000

367 floreg 130010000

368 floreg 130020000

369 floreg 160010000

372 floreg 170010000

373 floreg 180010000

373 floreg 330030000

\*

374 tempg 160010000

377 tempg 100100000

378 tempg 110010000

379 tempg 120010000

380 tempg 130010000

\*

383 sattemp 160010000

386 sattemp 100100000

387 sattemp 110010000

388 sattemp 120010000

389 sattemp 130010000

\*

392 cntrlvar 130 \* condensate level, frac.

\*

20800001 hif 160010000

20800002 hif 170010000

20800003 hif 180010000

20800004 hif 110010000

20800005 hif 120010000

20800006 hif 130010000

20800007 hif 130020000

\*

20800008 hig 160010000

20800009 hig 170010000

20800010 hig 180010000

```

20800011 hig      110010000
20800012 hig      120010000
20800013 hig      130010000
20800014 hig      130020000
*
*condensate level,fraction
*
20513000 con-lvl  sum   1.0   0.0   1
20513001 0.0   0.85         voidf  160010000
*
*****
* hydrodynamic data
*****
*
*component 100 : pipe ( steam generator )
*
1000000 sgtank   pipe
1000001 10
1000101 0.0      1
1000102 0.78540  9
1000103 0.0      10
1000301 0.205    10
1000401 0.02197  1
1000402 0.0      9
1000403 0.02197  10
1000601 90.0     10
1000801 0.000046 0.0  10
1001001 00000    10
1001101 000000   9
1001201 002  1.430e5 0.0  0.0  0.0  0.0  6
1001202 002  1.430e5 0.8  0.0  0.0  0.0  7
1001203 002  1.430e5 1.0  0.0  0.0  0.0  10
1001300 1
1001301 0.0  0.0  0.0  9
*
*branch 101 : branch (from S/G to horizontal pipe)
*
1010000 sg_up branch
1010001 2 1
1010101 0.00126 0.34 0. 0. 90. 0.34 0.000046
1010102 0.0 00000
1010200 002 1.4300e5 1.0
1011101 100100002 101010001 0.00126 0.5 0.5
000100
1011201 0.0 0.0 0.0
1012101 101010002 110010001 0.00126 0.63 0.63
000100
1012201 0.0 0.0 0.0
*
*component 110 : pipe (horizontal pipe above SG)
*

```

```

1100000 horzpl   pipe
1100001 3
1100101 0.00126 1
1100102 0.00049 3
*1100201 0.00049 2
1100301 0.22    1
1100302 0.90    3
1100401 0.0     3
1100601 0.0     3
1100801 0.000046 0.0 3
1100901 0.43 0.43 1
1100902 0.0 0.0 2
1101001 00000   3
1101101 000100  1
1101102 000000  2
1101201 002  1.4300e5 1.0 0.0 0.0 0.0 3
*1102001 boron concentration should be considered
in future job
1101300 1
1101301 0.0 0.0 0.0 2
*
*junction 111 : single junction
*
1110000 vortexm  sngljun
1110101 110030002 120010001 0.0 1.26 1.26
000100
1110201 1 0.0 0.0 0.0
*
*component 120 : pipe (horizontal pipe above SG)
*
1200000 horzpl2   pipe
1200001 3
1200101 0.00015 3
1200301 0.17    1
1200302 0.84    3
*1200501 90.0   1
*1200502 0.0    3
1200601 0.0     3
1200801 0.000046 0.0 3
1200901 0.81 0.81 1
1200902 0.0 0.0 2
1201001 00000   3
1201101 000000  2
1201201 002  1.4300e5 1.0 0.0 0.0 0.0 3
1201300 1
1201301 0.0 0.0 0.0 2
*
*junction 121 : single junction
*
1210000 pip1     sngljun

```

```

1210101 120030002 130010001 0.00015 1.62 1.62
000000
1210201 1 0.0 0.0 0.0
*
*component 130 : pipe (vertical pipe above CMT)
*
1300000 vertpip pipe
1300001 5
1300101 0.00015 5
1300301 0.204 5
1300401 0.0 5
1300601 -90.0 5
1300801 0.000046 0.0 5
1300901 0.0 0.0 1
1300902 0.54 0.54 2
1300903 0.0 0.0 4
1301001 00000 5
1301101 000000 4
1301201 003 1.4300e5 304.0 0.0 0.0 0.0
5
1301300 1
1301301 0.0 0.0 0.0 4 *
*
*junction 131 : junction from vertical pipe to the
cmt
*
1310000 cmtjun sngljun
1310101 130050002 160010001 0.00015 1.0
1.0
1310102 000100
1310201 1 0.0 0.0 0.0
*
*
*volume 160 : single volume
*
1600000 cmt snglvol
1600101 0.32170 0.85 0.0 0.0 -90. -0.85
0.000046
1600102 0.0 00000
1600200 003 1.4300e5 304.27
*
*component 160 : pipe (cmt)
*
*1600000 cmttank pipe
*1600001 2
*1600101 0.32170 2
*1600301 0.425 1
*1600302 0.425 2
*1600401 0.0 2
*1600601 -90.0 2
*1600801 0.000046 0.0 2

```

```

*1601001 00000 2
*1601101 000000 1
*1601201 003 1.4300e5 304.0 0.0 0.0 0.0 2
*1601300 1
*1601301 0.0 0.0 0.0 1
*
*junction 161 : valve junction (valve below CMT)
*
1610000 dowvvv valve
1610101 160010002 170010001 0.00071 1.75
1.75 000100
1610201 1 0.0 0.0 0.0
1610300 srvvlv
1610301 120
*
*component 170 : vertical pipe below CMT
*
1700000 belopip1 pipe
1700001 2
1700101 0.00071 1
1700102 0.00015 2
1700301 0.30 1
1700302 0.12 2
1700401 0.0 2
1700601 -90.0 2
1700801 0.000046 0.0 2
1700901 0.394 0.394 1
1701001 00000 2
1701101 000100 1
1701201 003 1.013e5 293. 0.0 0.0 0.0 1
1701202 003 1.013e5 293. 0.0 0.0 0.0 2
1701300 1
1701301 0.0 0.0 0.0 1
*
*junction 171 : junction between vertical and
horizontal pipes
*
1710000 beljun sngljun
1710101 170020002 180010001 0.00015 0.5
1000.75
1710102 000100
1710201 1 0.0 0.0 0.0
*
*component 180 : horizontal pipe below CMT
*
1800000 belopip2 pipe
1800001 2
1800101 0.00015 2
1800301 1.0 2
1800401 0.0 2

```



```

1800601 0.0      2
1800801 0.000046 0.0  2
1801001 00000    2
1801101 000000   1
1801201 004    1.013e5 293. 0.0 0.0 0.0 1
1801202 004    1.013e5 293. 0.0 0.0 0.0 2
1801300 1
1801301 0.0    0.0 0.0 1
*
*junction 181 : junction to atmosphere
*
1810000 atmjun  sngljun
1810101 180020002 200000000 0.00015 1.75
1.75
1810102 000100
1810201 1 0.0 0.0 0.0
*
*component 200 : atmosphere
*
2000000 air  tmdpvol
2000101 0.0 100.0 1000.0 0.0 0.0.
2000102 0.0 0.0 00
2000200 004
2000201 0.0 1.013e5 293.0 0.0
*
*****
* Natural circulation line
*****
*
*branch 310 : branch (from S/G to circulation line
inlet)
*
3100000 nc_in branch
3100001 2 1
3100101 0.00049 0.17 0. 0. 0.0 0.000046
3100102 0.0 00000
3100200 003 1.4300e5 300.0
3101101 100040004 310010001 0.00049 0.5 0.5
000120
3101201 0.0 0.0 0.0
3102101 310010002 320010001 0.00015 1.12 1.12
000100
3102201 0.0 0.0 0.0
*
*component 320 : natural circulation line
*
3200000 nc_hp1  pipe
3200001 6
3200101 0.00015 6
3200301 0.13 1
3200302 0.436 6

```

```

3200401 0.0      6
3200601 -90.0    1
3200602 0.0      6
3200801 0.000046 0.0  6
3200901 0.81 0.81 1
3200902 0.0 0.0 5
3201001 00000    6
3201101 000000   5
3201201 003 1.4300e5 300. 0.0 0.0 0.0 6
3201300 1
3201301 0.0 0.0 0.0 5
*
*junction 325
*
3250000 hp_jun1  sngljun
3250101 320060002 330010001 0.00015 0.739
0.739
3250102 000100
3250201 1 0.0 0.0 0.0
*
*component 330 : natural circulation line
*
3300000 nc_hp2  pipe
3300001 4
3300101 0.00126 4
3300301 0.14 1
3300302 0.23 3
3300303 0.4225 4
3300401 0.0 4
3300601 0.0 1
3300602 90.0 4
3300801 0.000046 0.0 4
3300901 0.63 0.63 1
3300902 0.0 0.0 3
3301001 00000    4
3301101 000000   3
3301201 003 1.4300e5 300. 0.0 0.0 0.0 4
3301300 1
3301301 0.0 0.0 0.0 3
*
*
*junction 335 : natural circulation valve junction
*
3350000 dowvv  valve
3350101 330040002 340010001 0.00126 1.75
1.75 000100
3350201 1 0.0 0.0 0.0
3350300 srvv1v
3350301 120
*
*component 340 : natural circulation line

```

```

*
3400000 nc_hp3   pipe
3400001 4
3400101 0.00126 4
3400301 0.223   3
3400302 0.1     4
3400401 0.0     4
3400601 0.0     3
3400602 -90.0   4
3400801 0.000046 0.0 4
3400901 0.0     0.0 1
3400902 0.63   0.63 3
3401001 00000   4
3401101 00000   3
3401201 003    1.4300e5 300. 0.0 0.0 0.0 4
3401300 1
3401301 0.0    0.0 0.0 3

```

```

*
*junction 345 : junction from natural circulation
*           pipe to the cmt

```

```

*
3450000 cmtjun  sngljun
3450101 340040002 160010001 0.00126 0.1
0.1
3450102 000100
3450201 1 0.0 0.0 0.0

```

```

*
*****

```

```

*valve control
*****

```

```

*
20512000 vlvarea  function  1.0 0.0 0
20512001 time     0         003

```

```

*
*

```

```

*****

```

```

*valve table
*****

```

```

*
20200300 normarea
20200301 0.0 0.0
20200302 10. 0.0
20200303 10.01 1.0
20200306 10000. 1.0

```

```

*

```

```

*****

```

```

* heat structure input
*****

```

```

*

```

```

* cmt (1160)

```

```

*
*11600000 1 3 1 1 0.0
*11600100 0 2
*11600101 0.0225 2
*11600201 5 2
*11600301 0.0 2
*11600400 0
**11600401 288.0 3
*11600501 160010000 1 1 0 0.32170 1
*11600601 0 0 0 1 0.32170
1
*11600701 0 0.0 0.0 0.0 1
*11600801 0.0 10.0 10.0 10.0 10.0 0.0 0.0
1.0 1
*11600901 0.0 10.0 10.0 10.0 10.0 0.0 0.0
1.0 1

```

```

*
* cmt (1160-1)

```

```

*
*11601000 10 3 2 1 0.32
*11601100 0 2
*11601101 0.0025 2
*11601201 5 2
*11601301 0.0 2
**11601400 0
*11601401 288.0 3
*11601501 160010000 10000 1 1 0.085 10
*11601601 0 0 0 1 0.085 10
*11601701 0 0.0 0.0 0.0 10
*11601801 0.0 10.0 10.0 10.0 10.0 0.0 0.0
1.0 10
*11601901 0.0 10.0 10.0 10.0 10.0 0.0 0.0
1.0 10

```

```

*

```

```

* SG (1100)

```

```

*
*11000000 10 3 2 1 0.5
*11000100 0 2
*11000101 0.006 2
*11000201 5 2
*11000301 0.0 2
*11000400 0
**11000401 373.14 3
*11000501 100010000 10000 1 1 0.205 10
*11000601 0 0 0 1 0.205 10
*11000701 0 0.0 0.0 0.0 10
*11000801 0.0 10.0 10.0 10.0 10.0 0.0 0.0
1.0 10
*11000901 0.0 10.0 10.0 10.0 10.0 0.0 0.0
1.0 10

```

```

*
*
*****
* heat structure input for electric heater
*****
11005000 3 4 2 1 0.0
11005100 0 2
11005101 0.0015 2 0.001 3
11005201 11 2 5 3
11005301 1.0 2 0.0 3
11005400 0
11005401 384.4 4
11005501 0 0 0 1 36.0 3
11005601 100010000 10000 1 1 36.0 3
11005701 10212 1.0 0.0 0.0 3
11005901 0.0 10.0 10.0 10.0 10.0 0.0 0.0 1.0
3
*
* power table
*
*20221200 power 501 1. 100000.0
*20221201 -1. 0.0
*20221202 0. 1.0
*20221203 100. 1.0
*20221204 1000. 1.0
*
20100500 tbl/fctn 1 1 * s - steel
20101100 tbl/fctn 1 1 * PZR
heater (MgO)
*****
* MgO(011)
*****
* temp (k) volumetric heat capacity
(j/m3.k)
20101151 0.293e+03 .2600000e+07
20101152 0.450e+03 .2835000e+07
20101153 0.800e+03 .3402000e+07
20101154 1.120e+03 .3726000e+07
20101155 1.922038e+03 .3726000e+07
*
* temp (k) thermal conductivity
(w/m.k)
20101101 0.29320e+03 81.40
20101102 1.27320e+03 100.47
20101102 1.9220389e+03 100.47 *
*
*****
* stainless steel (005) 18cr-8ni
*****

```

```

* temp (k) volumetric heat capacity
(j/m3.k)
20100551 .2742611e+03 .3831330e+07
*20100551 .2942611e+03 .3831330e+07
20100552 .3109278e+03 .3831330e+07
20100553 .3664834e+03 .3985580e+07
20100554 .4220389e+03 .4105300e+07
20100555 .4775945e+03 .4224090e+07
20100556 .5331500e+03 .4308800e+07
20100557 .5887056e+03 .4359790e+07
20100558 .6442611e+03 .4410320e+07
20100559 .8109278e+03 .4561910e+07
20100560 .9220389e+03 .4625250e+07
20100561 1.9220389e+03 .4625250e+07 *
*
* temp (k) thermal conductivity
(w/m.k)
20100501 .2732611e+03 .1489124e+02
20100502 .2942611e+03 .1489124e+02
20100503 .3109278e+03 .1505739e+02
20100504 .3664834e+03 .1609584e+02
20100505 .4220389e+03 .1696813e+02
20100506 .4775945e+03 .1800657e+02
20100507 .5331500e+03 .1885809e+02
20100508 .5887056e+03 .1956423e+02
20100509 .6442611e+03 .2041575e+02
20100510 .8109278e+03 .2297030e+02
20100511 .9220389e+03 .2423029e+02
20100512 1.9220389e+03 .2423029e+02 *
*
*****
* heater control
*****
*
20521200 heater constant 0.0
*
*
. end of file

```

5) PI041

=RELAP5/MOD3.1 CMT 1 Nodes

```

*PI041 simulation
*CMT node : 1 node
*water valve: 10sec. opened
*
*job cards
100 new transnt
101 run
*
110 air
*
*time step cards
201 10.0 1.0e-12 0.1 3 10 100 100
*202 20.0 1.0e-12 0.005 3 100 500 500
202 20.0 1.0e-12 0.005 3 200 1000 1000
203 1600. 1.0e-12 0.1 3 10 2500 2500
*205 2600. 1.0e-12 0.1 3 10 2500 2500
*
*minor editor cards
*
*
301 tempf 160010000 * CMT - node 1
311 p 100100000
312 p 130050000
313 p 160010000
*
*
314 tempf 130020000
315 tempf 120010000
316 tempf 120020000
317 tempf 100050000
318 tempf 100010000
*
319 voidg 160010000 * CMT - node 1
322 voidg 130010000
323 voidg 130020000
324 voidg 120010000
325 voidg 110010000
326 voidg 100100000
327 voidg 100050000
*
328 mflowj 130040000
329 mflowj 111000000
330 mflowj 121000000
331 mflowj 131000000
332 mflowj 161000000
334 mflowj 170010000
335 mflowj 171000000
336 mflowj 181000000

```

```

*
*
*
355 vapgen 160010000 * CMT - node 1
358 vapgen 170010000
359 vapgen 180010000
360 vapgen 110010000
361 vapgen 120010000
362 vapgen 130010000
363 vapgen 130020000
*
364 floreg 110010000
365 floreg 120010000
366 floreg 120020000
367 floreg 130010000
368 floreg 130020000
369 floreg 160010000
372 floreg 170010000
373 floreg 180010000
*
374 tempg 160010000
377 tempg 100100000
378 tempg 110010000
379 tempg 120010000
380 tempg 130010000
*
383 sattemp 160010000
386 sattemp 100100000
387 sattemp 110010000
388 sattemp 120010000
389 sattemp 130010000
*
392 cntrlvar 130 * condensate level, frac.
20800001 hif 160010000 * CMT - node 1
20800002 hif 170010000
20800003 hif 180010000
20800004 hif 110010000
20800005 hif 120010000
20800006 hif 130010000
20800007 hif 130020000
*
20800008 hig 160010000 * CMT - node 1
20800009 hig 170010000
20800010 hig 180010000
20800011 hig 110010000
20800012 hig 120010000
20800013 hig 130010000
20800014 hig 130020000
*
*condensate level,fraction
*

```

```

20513000 con-lvl sum 1.0 0.0 1
20513001 0.0 0.85 voidf 160010000
*
*****
* hydrodynamic data
*****
*
*component 100 : pipe ( steam generator )
*
1000000 sgtank pipe
1000001 10
1000101 0.0 1
1000102 0.78540 9
1000103 0.0 10
1000301 0.205 10
1000401 0.02197 1
1000402 0.0 9
1000403 0.02197 10
1000601 90.0 10
1000801 0.000046 0.0 10
1001001 00000 10
1001101 000000 9
1001201 002 4.0e5 0.0 0.0 0.0 0.0 4
1001202 002 4.0e5 0.5 0.0 0.0 0.0 5
1001203 002 4.0e5 1.0 0.0 0.0 0.0 10
1001300 1
1001301 0.0 0.0 0.0 9
*
*branch 101 : branch (from S/G to horizontal pipe)
*
1010000 sg_up branch
1010001 2 1
1010101 0.00126 0.34 0. 0. 90. 0.34 0.000046
1010102 0.0 00000
1010200 002 4.00e5 1.0
1011101 100100002 101010001 0.00126 0.5 0.5
000100
1011201 0.0 0.0 0.0
1012101 101010002 110010001 0.00126 0.63 0.63
000100
1012201 0.0 0.0 0.0
*
*component 110 : pipe (horizontal pipe above SG)
*
1100000 horzpl pipe
1100001 3
1100101 0.00126 1
1100102 0.00049 3
*1100201 0.00049 2
1100301 0.22 1
1100302 0.90 3

```

```

1100401 0.0 3
1100601 0.0 3
1100801 0.000046 0.0 3
1100901 0.43 0.43 1
1100902 0.0 0.0 2
1101001 00000 3
1101101 000100 1
1101102 000000 2
1101201 002 4.0e5 1.0 0.0 0.0 0.0 3
1101300 1
1101301 0.0 0.0 0.0 2
*
*junction 111 : single junction
*
1110000 vortexm sngljun
1110101 110030002 120010001 0.0 1.26 1.26
000100
1110201 1 0.0 0.0 0.0
*
*component 120 : pipe (horizontal pipe above SG)
*
1200000 horzpz pipe
1200001 3
1200101 0.00015 3
1200301 0.17 1
1200302 0.84 3
*1200501 90.0 1
*1200502 0.0 3
1200601 0.0 3
1200801 0.000046 0.0 3
1200901 0.81 0.81 1
1200902 0.0 0.0 2
1201001 00000 3
1201101 000000 2
1201201 002 4.0e5 1.0 0.0 0.0 0.0 3
1201300 1
1201301 0.0 0.0 0.0 2
*
*junction 121 : single junction
*
1210000 pip1 sngljun
1210101 120030002 130010001 0.00015 1.62 1.62
000000
1210201 1 0.0 0.0 0.0
*
*component 130 : pipe (vertical pipe above CMT)
*
1300000 vertpip pipe
1300001 5
1300101 0.00015 5

```

```

1300301 0.204 5
1300401 0.0 5
1300601 -90.0 5
1300801 0.000046 0.0 5
1300901 0.0 0.0 1
1300902 0.54 0.54 2
1300903 0.0 0.0 4
1301001 00000 5
1301101 000000 4
1301201 003 4.00e5 304.0 0.0 0.0 0.0 5
1301300 1
1301301 0.0 0.0 0.0 4 *
*
*junction 131 : junction from vertical pipe to the
test section
*
1310000 testse sngljun
1310101 130050002 160010001 0.00015 1.0
1.0
1310102 000100
1310201 1 0.0 0.0 0.0
*
*
*volume 160 : single volume
*
1600000 cmt snglvol
1600101 0.32170 0.85 0.0 0.0 -90. -0.85
0.000046
1600102 0.0 00000
1600200 003 1.4300e5 304.1
*
*component 160 : pipe (cmt)
*
*1600000 cmmtank pipe
*1600001 2
*1600101 0.32170 2
*1600301 0.425 1
*1600302 0.425 2
*1600401 0.0 2
*1600601 -90.0 2
*1600801 0.000046 0.0 2
*1601001 00000 2
*1601101 000000 1
*1601201 003 1.4300e5 304.0 0.0 0.0 0.0 2
*1601300 1
*1601301 0.0 0.0 0.0 1
*
*junction 161 : valve junction (valve below test
section)
*
1610000 dowvv valve

```

```

1610101 160010002 170010001 0.00071 1.75
1.75 000100
1610201 1 0.0 0.0 0.0
1610300 srvvlv
1610301 120
*
*component 170 : vertical pipe below CMT
*
1700000 belopipl pipe
1700001 2
1700101 0.00071 1
1700102 0.00015 2
1700301 0.30 1
1700302 0.12 2
1700401 0.0 2
1700601 -90.0 2
1700801 0.000046 0.0 2
1700901 0.3750 0.3750 1
1701001 00000 2
1701101 000100 1
1701201 003 1.013e5 293. 0.0 0.0 0.0 1
1701202 003 1.013e5 293. 0.0 0.0 0.0 2
1701300 1
1701301 0.0 0.0 0.0 1
*
*junction 171 : junction between vertical and
horizontal pipes
*
1710000 beljun sngljun
1710101 170020002 180010001 0.00015 0.5
1000.75
1710102 000100
1710201 1 0.0 0.0 0.0
*
*component 180 : horizontal pipe below CMT
*
1800000 belopip2 pipe
1800001 2
1800101 0.00015 2
1800301 1.0 2
1800401 0.0 2
1800601 0.0 2
1800801 0.000046 0.0 2
1801001 00000 2
1801101 000000 1
1801201 004 1.013e5 293. 0.0 0.0 0.0 1
1801202 004 1.013e5 293. 0.0 0.0 0.0 2
1801300 1
1801301 0.0 0.0 0.0 1

```

```

*
*junction 181 : junction to atmosphere
*
1810000 atmjun  sngljun
1810101 180020002  200000000  0.00015  1.75
1.75
1810102 000100
1810201 1  0.0  0.0  0.0
*
*component 200 : atmosphere
*
2000000 air  trmdpvol
2000101 0.0  100.0  1000.0  0.0  0. 0.
2000102 0.0  0.0  00
2000200 004
2000201 0.0  1.013e5  293.0  0.0
*
**
*****
*valve control
*****
*
20512000 vlvarea  function  1.0  0.0  0
20512001 time  0  003
*
*
*****
*valve table
*****
*
20200300 normarea
20200301 0.0  0.0
20200302 10.  0.0
20200303 10.01  1.0
20200306 10000. 1.0
*
*****
* heat structure input
*****
*
* cmt (1160)
*
*11600000  1  3  1  1  0.0
*11600100  0  2
*11600101  0.0225  2
*11600201  5  2
*11600301  0.0  2

```

```

*11600400  0
**11600401  288.0  3
*11600501  160010000  1  1  0  0.32170  1
*11600601  0  0  0  1  0.32170
1
*11600701  0  0.0  0.0  0.0  1
*11600801  0.0  10.0  10.0  10.0  10.0  0.0  0.0
1.0  1
*11600901  0.0  10.0  10.0  10.0  10.0  0.0  0.0
1.0  1
*
* cmt (1160-1)
*
*11601000  10  3  2  1  0.32
*11601100  0  2
*11601101  0.0025  2
*11601201  5  2
*11601301  0.0  2
**11601400  0
*11601401  288.0  3
*11601501  160010000  10000  1  1  0.085  10
*11601601  0  0  0  1  0.085  10
*11601701  0  0.0  0.0  0.0  10
*11601801  0.0  10.0  10.0  10.0  10.0  0.0  0.0
1.0  10
*11601901  0.0  10.0  10.0  10.0  10.0  0.0  0.0
1.0  10
*
* SG (1100)
*
*11000000  10  3  2  1  0.5
*11000100  0  2
*11000101  0.006  2
*11000201  5  2
*11000301  0.0  2
*11000400  0
**11000401  373.14  3
*11000501  100010000  10000  1  1  0.205  10
*11000601  0  0  0  1  0.205  10
*11000701  0  0.0  0.0  0.0  10
*11000801  0.0  10.0  10.0  10.0  10.0  0.0  0.0
1.0  10
*11000901  0.0  10.0  10.0  10.0  10.0  0.0  0.0
1.0  10
*
*
*****
* heat structure input for electric heater
*****
11005000  3  4  2  1  0.0

```

```

11005100 0 2
11005101 0.0015 2 0.001 3
11005201 11 2 5 3
11005301 1.0 2 0.0 3
11005400 0
11005401 384.4 4
11005501 0 0 0 1 36.0 3
11005601 100010000 10000 1 1 36.0 3
11005701 10212 1.0 0.0 0.0 3
11005901 0.0 10.0 10.0 10.0 10.0 0.0 0.0 1.0
3

```

```

*
* power table
*
*20221200 power 501 1. 100000.0
*20221201 -1. 0.0
*20221202 0. 1.0
*20221203 100. 1.0
*20221204 1000. 1.0
*

```

```

20100500 tbl/fctn 1 1 * s - steel
20101100 tbl/fctn 1 1 * PZR heater (MgO)

```

```

*****
* MgO (011)
*****

```

```

*          temp (k)    volumetric heat capacity
                      (j/m3.k)
20101151    0.293e+03    .26000000e+07
20101152    0.450e+03    .28350000e+07
20101153    0.800e+03    .34020000e+07
20101154    1.120e+03    .37260000e+07
20101155    1.922038e+03    .37260000e+07

```

```

*          temp (k)    thermal conductivity
(w/m.k)
20101101    0.29320e+03    81.40
20101102    1.27320e+03    100.47
20101102    1.9220389e+03    100.47    *

```

```

*****
*****

```

```

* stainless steel (005) 18cr-8ni

```

```

*          temp (k)    volumetric heat capacity
(j/m3.k)
20100551    .2742611e+03    .3831330e+07
*20100551    .2942611e+03    .3831330e+07
20100552    .3109278e+03    .3831330e+07
20100553    .3664834e+03    .3985580e+07

```

```

20100554    .4220389e+03    .4105300e+07
20100555    .4775945e+03    .4224090e+07
20100556    .5331500e+03    .4308800e+07
20100557    .5887056e+03    .4359790e+07
20100558    .6442611e+03    .4410320e+07
20100559    .8109278e+03    .4561910e+07
20100560    .9220389e+03    .4625250e+07
20100561    1.9220389e+03    .4625250e+07    *

```

```

*
temp (k)          thermal conductivity
(w/m.k)

```

```

20100501    .2732611e+03    .1489124e+02
20100502    .2942611e+03    .1489124e+02
20100503    .3109278e+03    .1505739e+02
20100504    .3664834e+03    .1609584e+02
20100505    .4220389e+03    .1696813e+02
20100506    .4775945e+03    .1800657e+02
20100507    .5331500e+03    .1885809e+02
20100508    .5887056e+03    .1956423e+02
20100509    .6442611e+03    .2041575e+02
20100510    .8109278e+03    .2297030e+02
20100511    .9220389e+03    .2423029e+02
20100512    1.9220389e+03    .2423029e+02    *

```

```

*
*****
* heater control
*****

```

```

*
20521200 heater constant 0.0

```

```

*
. end of file

```



6) PN041

=RELAP5/MOD3.1 CMT 1 Nodes

```

* PN041 simulation
* CMT node : 1 node
* water valve: 10sec. opened
* natural circulation line v/v : 10sec. opened
*
*job cards
100 new transnt
101 run
*
110 air
*
*time step cards
201 10.0 1.0e-12 0.1 3 10 100 100
202 20.0 1.0e-12 0.005 3 100 500 500
203 40.0 1.0e-12 0.1 3 10 100 100
204 60.0 1.0e-12 0.005 3 100 500 500
205 1000.0 1.0e-12 0.1 3 10 2500 2500
*
*minor editor cards
*
301 tempf 160010000 * CMT - node 1
311 p 100100000
312 p 130050000
313 p 160010000
*
*
314 tempf 130020000
315 tempf 120010000
316 tempf 120020000
317 tempf 100050000
318 tempf 100010000
319 tempf 320010000
*
*
320 voidg 160010000 * CMT - node 1
321 voidg 130010000
322 voidg 130020000
323 voidg 120010000
324 voidg 110010000
325 voidg 100100000
326 voidg 100050000
*
*
328 mflowj 130040000
329 mflowj 111000000
330 mflowj 121000000
331 mflowj 131000000
332 mflowj 161000000
334 mflowj 170010000
335 mflowj 171000000

```

```

336 mflowj 181000000
337 mflowj 310020000
338 mflowj 325000000
339 mflowj 345000000
*
355 vapgen 160010000 * CMT - node 1
358 vapgen 170010000
359 vapgen 180010000
360 vapgen 110010000
361 vapgen 120010000
362 vapgen 130010000
363 vapgen 130020000
*
364 floreg 110010000
365 floreg 120010000
366 floreg 120020000
367 floreg 130010000
368 floreg 130020000
369 floreg 160010000
372 floreg 170010000
373 floreg 180010000
373 floreg 330030000
*
374 tempg 160010000
377 tempg 100100000
378 tempg 110010000
379 tempg 120010000
380 tempg 130010000
*
383 sattemp 160010000
386 sattemp 100100000
387 sattemp 110010000
388 sattemp 120010000
389 sattemp 130010000
*
392 cntrlvar 130 * condensate level, frac.
*
20800001 hif 160010000 * CMT - node 1
20800002 hif 170010000
20800003 hif 180010000
20800004 hif 110010000
20800005 hif 120010000
20800006 hif 130010000
20800007 hif 130020000
*
20800008 hig 160010000
20800009 hig 170010000
20800010 hig 180010000
20800011 hig 110010000
20800012 hig 120010000
20800013 hig 130010000

```

```

20800014 hig      130020000
*
*condensate level,fraction
*
20513000 con-lvl  sum   1.0   0.0   1
20513001 0.0   0.85      voidf 160010000
*
*****
* hydrodynamic data
*****
*
*component 100 : pipe ( steam generator )
*
1000000 sgtank   pipe
1000001 10
1000101 0.0      1
1000102 0.78540  9
1000103 0.0      10
1000301 0.205    10
1000401 0.02197  1
1000402 0.0      9
1000403 0.02197  10
1000601 90.0     10
1000801 0.000046 0.0 10
1001001 00000    10
1001101 000000   9
1001201 002   4.0e5 0.0 0.0 0.0 0.0 6
1001202 002   4.0e5 0.8 0.0 0.0 0.0 7
1001203 002   4.0e5 1.0 0.0 0.0 0.0 10
1001300 1
1001301 0.0   0.0   0.0 9
*
*branch 101 : branch (from S/G to horizontal pipe)
*
1010000 sg_up branch
1010001 2 1
1010101 0.00126 0.34 0. 0. 90. 0.34 0.000046
1010102 0.0 00000
1010200 002 4.0e5 1.0
1011101 100100002 101010001 0.00126 0.5 0.5
000100
1011201 0.0 0.0 0.0
1012101 101010002 110010001 0.00126 0.63 0.63
000100
1012201 0.0 0.0 0.0
*
*component 110 : pipe (horizontal pipe above SG)
*
1100000 horzp1   pipe
1100001 3
1100101 0.00126 1

```

```

1100102 0.00049 3
*1100201 0.00049 2
1100301 0.22     1
1100302 0.90     3
1100401 0.0      3
1100601 0.0      3
1100801 0.000046 0.0 3
1100901 0.43 0.43 1
1100902 0.0 0.0 2
1101001 00000    3
1101101 000100   1
1101102 000000   2
1101201 002   4.0e5 1.0 0.0 0.0 0.0 3
1101300 1
1101301 0.0   0.0   0.0 2
*
*junction 111 : single junction
*
1110000 vortexm  sngljun
1110101 110030002 120010001 0.0 1.26 1.26
000100
1110201 1 0.0 0.0 0.0
*
*component 120 : pipe (horizontal pipe above SG)
*
1200000 horzp2   pipe
1200001 3
1200101 0.00015 3
1200301 0.17     1
1200302 0.84     3
*1200501 90.0   1
*1200502 0.0     3
1200601 0.0      3
1200801 0.000046 0.0 3
1200901 0.81 0.81 1
1200902 0.0 0.0 2
1201001 00000    3
1201101 000000   2
1201201 002   4.0e5 1.0 0.0 0.0 0.0 3
1201300 1
1201301 0.0   0.0   0.0 2
*
*junction 121 : single junction
*
1210000 pip1     sngljun
1210101 120030002 130010001 0.00015 1.62 1.62
000000
1210201 1 0.0 0.0 0.0
*
*component 130 : pipe (vertical pipe above CMT)

```

```

*
1300000 vertpip   pipe
1300001 5
1300101 0.00015  5
1300301 0.204    5
1300401 0.0      5
1300601 -90.0    5
1300801 0.000046 0.0  5
1300901 0.0  0.0  1
1300902 0.54  0.54  2
1300903 0.0  0.0  4
1301001 00000  5
1301101 000000  4
1301201 003  4.0e5  304.0  0.0  0.0  0.0  5
1301300 1
1301301 0.0  0.0  0.0  4 *
*
*junction 131 : junction from vertical pipe to the
cmt
*
1310000 cmtjun   sngljun
1310101 130050002  160010001  0.00015  1.0
1.0
1310102 000100
1310201 1  0.0  0.0  0.0
*
*
*volume 160 : single volume
*
1600000 cmt   snglvol
1600101 0.32170  0.85  0.0  0.0  -90.  -0.85
0.000046
1600102 0.0  00000
1600200 003  4.0e5  304.3
*
*component 160 : pipe (cmt)
*
*1600000 cmttank pipe
*1600001 2
*1600101 0.32170  2
*1600301 0.425  1
*1600302 0.425  2
*1600401 0.0  2
*1600601 -90.0  2
*1600801 0.000046 0.0  2
*1601001 00000  2
*1601101 000000  1
*1601201 003  1.4300e5  304.0  0.0  0.0  0.0  2
*1601300 1
*1601301 0.0  0.0  0.0  1
*

```

```

*junction 161 : valve junction (valve below CMT)
*
1610000 dowvv   valve
.1610101 160010002  170010001  0.00071  1.75
1.75  000100
1610201 1  0.0  0.0  0.0
1610300 srvvlv
1610301 120
*
*component 170 : vertical pipe below CMT
*
1700000 belopip1 pipe
1700001 2
1700101 0.00071  1
1700102 0.00015  2
1700301 0.30  1
1700302 0.12  2
1700401 0.0  2
1700601 -90.0  2
1700801 0.000046 0.0  2
1700901 0.394  0.394  1
1701001 00000  2
1701101 000100  1
1701201 003  1.013e5  293.  0.0  0.0  0.0  1
1701202 003  1.013e5  293.  0.0  0.0  0.0  2
1701300 1
1701301 0.0  0.0  0.0  1
*
*
*junction 171 : junction between vertical and
horizontal pipes
*
1710000 beljun   sngljun
1710101 170020002  180010001  0.00015  0.5
1000.75
1710102 000100
1710201 1  0.0  0.0  0.0
*
*component 180 : horizontal pipe below CMT
*
1800000 belopip2 pipe
1800001 2
1800101 0.00015  2
1800301 1.0  2
1800401 0.0  2
1800601 0.0  2
1800801 0.000046 0.0  2
1801001 00000  2
1801101 000000  1
1801201 004  1.013e5  293.  0.0  0.0  0.0  1
1801202 004  1.013e5  293.  0.0  0.0  0.0  2

```

```

1801300 1
1801301 0.0 0.0 0.0 1
*
*junction 181 : junction to atmosphere
*
1810000 atmjun  sngljun
1810101 180020002  200000000  0.00015  1.75
1.75
1810102 000100
1810201 1 0.0 0.0 0.0
*
*component 200 : atmosphere
*
2000000 air  tmdpvol
2000101 0.0 100.0 1000.0 0.0 0.0
2000102 0.0 0.0 00
2000200 004
2000201 0.0 1.013e5 293.0 0.0
*
*****
* Natural circulation line
*****
*
*branch 310 : branch (from S/G to circulation line
inlet)
*
3100000 nc_in branch
3100001 2 1
3100101 0.00049 0.17 0.0 0.0 0.0 0.000046
3100102 0.0 00000
3100200 003 4.0e5 300.0
3101101 100040004 310010001 0.00049 0.5 0.5
000120
3101201 0.0 0.0 0.0
3102101 310010002 320010001 0.00015 1.12 1.12
000100
3102201 0.0 0.0 0.0
*
*component 320 : natural circulation line
*
3200000 nc_hp1  pipe
3200001 6
3200101 0.00015 6
3200301 0.13 1
3200302 0.436 6
3200401 0.0 6
3200601 -90.0 1
3200602 0.0 6
3200801 0.000046 0.0 6
3200901 0.81 0.81 1
3200902 0.0 0.0 5

```

```

3201001 00000 6
3201101 000000 5
3201201 003 4.0e5 300. 0.0 0.0 0.0 6
3201300 1
3201301 0.0 0.0 0.0 5
*
*junction 325
*
3250000 hp_jun1  sngljun
3250101 320060002 330010001 0.00015 0.739
0.739
3250102 000100
3250201 1 0.0 0.0 0.0
*
*component 330 : natural circulation line
*
3300000 nc_hp2  pipe
3300001 4
3300101 0.00126 4
3300301 0.14 1
3300302 0.23 3
3300303 0.4225 4
3300401 0.0 4
3300601 0.0 1
3300602 90.0 4
3300801 0.000046 0.0 4
3300901 0.63 0.63 1
3300902 0.0 0.0 3
3301001 00000 4
3301101 000000 3
3301201 003 4.0e5 300. 0.0 0.0 0.0 4
3301300 1
3301301 0.0 0.0 0.0 3
*
*
*junction 335 : natural circulation valve junction
*
3350000 dowvv  valve
3350101 330040002 340010001 0.00126 1.75
1.75 000100
3350201 1 0.0 0.0 0.0
3350300 srvv1v
3350301 120
*
*component 340 : natural circulation line
*
3400000 nc_hp3  pipe
3400001 4
3400101 0.00126 4
3400301 0.223 3
3400302 0.1 4

```

```

3400401 0.0      4
3400601 0.0      3
3400602 -90.0    4
3400801 0.000046 0.0  4
3400901 0.0      0.0  1
3400902 0.63     0.63  3
3401001 00000    4
3401101 000000   3
3401201 003     4.0e5 300. 0.0 0.0 0.0 4
3401300 1
3401301 0.0     0.0   0.0  3

```

```

*
*junction 345 : junction from natural circulation
*           pipe to the cmt
*

```

```

3450000 cmtjun  sngljun
3450101 340040002 160010001 0.00126 1.0
1.0
3450102 000100
3450201 1 0.0 0.0 0.0

```

```

*
*****

```

```

*valve control

```

```

*****

```

```

*
20512000 vlvarea  function  1.0  0.0  0
20512001 time      0          003
*

```

```

*****

```

```

*valve table

```

```

*****

```

```

*
20200300 normarea
20200301 0.0  0.0
20200302 10.  0.0
20200303 10.01 1.0
20200306 10000. 1.0
*

```

```

*****

```

```

* heat structure input

```

```

*****

```

```

*
* cmt (1160)
*

```

```

*11600000 1 3 1 1 0.0
*11600100 0 2
*11600101 0.0225 2
*11600201 5 2

```

```

*11600301 0.0  2
*11600400 0
**11600401 288.0 3
*11600501 160010000 1 1 0 0.32170 1
*11600601 0 0 0 1 0.32170
1
*11600701 0 0.0 0.0 0.0 1
*11600801 0.0 10.0 10.0 10.0 10.0 0.0 0.0
1.0 1
*11600901 0.0 10.0 10.0 10.0 10.0 0.0 0.0
1.0 1
*

```

```

* cmt (1160-1)
*

```

```

*11601000 10 3 2 1 0.32
*11601100 0 2
*11601101 0.0025 2
*11601201 5 2
*11601301 0.0 2
**11601400 0
*11601401 288.0 3
*11601501 160010000 10000 1 1 0.085 10
*11601601 0 0 0 1 0.085 10
*11601701 0 0.0 0.0 0.0 10
*11601801 0.0 10.0 10.0 10.0 10.0 0.0 0.0
1.0 10
*11601901 0.0 10.0 10.0 10.0 10.0 0.0 0.0
1.0 10
*

```

```

* SG (1100)
*

```

```

*11000000 10 3 2 1 0.5
*11000100 0 2
*11000101 0.006 2
*11000201 5 2
*11000301 0.0 2
*11000400 0
**11000401 373.14 3
*11000501 100010000 10000 1 1 0.205 10
*11000601 0 0 0 1 0.205 10
*11000701 0 0.0 0.0 0.0 10
*11000801 0.0 10.0 10.0 10.0 10.0 0.0 0.0
1.0 10
*11000901 0.0 10.0 10.0 10.0 10.0 0.0 0.0
1.0 10
*

```

```

*
*****

```

```

* heat structure input for electric heater

```

```

*****

```

```

11005000 3 4 2 1 0.0
11005100 0 2
11005101 0.0015 2 0.001 3
11005201 11 2 5 3
11005301 1.0 2 0.0 3
11005400 0
11005401 384.4 4
11005501 0 0 0 1 36.0 3
11005601 100010000 10000 1 1 36.0 3
11005701 10212 1.0 0.0 0.0 3
11005901 0.0 10.0 10.0 10.0 10.0 0.0 0.0 1.0
3

```

```

*
* power table
*
*20221200 power 501 1. 100000.0
*20221201 -1. 0.0
*20221202 0. 1.0
*20221203 100. 1.0
*20221204 1000. 1.0
*

```

```

20100500 tbl/fctn 1 1 * s - steel
20101100 tbl/fctn 1 1 * PZR
heater (MgO)

```

```

*****
* MgO (011)
*****
* temp (k) volumetric heat capacity
(j/m3.k)
20101151 0.293e+03 .2600000e+07
20101152 0.450e+03 .2835000e+07
20101153 0.800e+03 .3402000e+07
20101154 1.120e+03 .3726000e+07
20101155 1.922038e+03 .3726000e+07
*

```

```

* temp (k) thermal conductivity
(w/m.k)
*
20101101 0.29320e+03 81.40
20101102 1.27320e+03 100.47
20101102 1.9220389e+03 100.47 *
*

```

```

*****
*****
* stainless steel (005) 18cr-8ni
*
* temp (k) volumetric heat capacity
(j/m3.k)
20100551 .2742611e+03 .3831330e+07
*20100551 .2942611e+03 .3831330e+07

```

```

20100552 .3109278e+03 .3831330e+07
20100553 .3664834e+03 .3985580e+07
20100554 .4220389e+03 .4105300e+07
20100555 .4775945e+03 .4224090e+07
20100556 .5331500e+03 .4308800e+07
20100557 .5887056e+03 .4359790e+07
20100558 .6442611e+03 .4410320e+07
20100559 .8109278e+03 .4561910e+07
20100560 .9220389e+03 .4625250e+07
20100561 1.9220389e+03 .4625250e+07 *

```

```

*
* temp (k) thermal conductivity
(w/m.k)

```

```

20100501 .2732611e+03 .1489124e+02
20100502 .2942611e+03 .1489124e+02
20100503 .3109278e+03 .1505739e+02
20100504 .3664834e+03 .1609584e+02
20100505 .4220389e+03 .1696813e+02
20100506 .4775945e+03 .1800657e+02
20100507 .5331500e+03 .1885809e+02
20100508 .5887056e+03 .1956423e+02
20100509 .6442611e+03 .2041575e+02
20100510 .8109278e+03 .2297030e+02
20100511 .9220389e+03 .2423029e+02
20100512 1.9220389e+03 .2423029e+02 *

```

```

*
*
*****

```

```

* heater control
*****

```

```

20521200 heater constant 0.0
*
. end of file

```

# Appendix B : Experimental Data

## 1) GI021

Psg : Pressure at steam generator(bar or Pa)

Pts : Pressure at test section(bar or Pa)

Tts : Temperature at test section(c)

Ws : steam flow rate(kg/sec)

Winj : injection flow rate(kg/sec)

Wnat : natural circulation flow(kg/sec)

Time	Tts	Psg(bar)	Pts(bar)	Ws	Winj
1.4300	31.01	1.43000	1.51000	0.00082	0.00694
2.6410	31.47	1.43000	1.51000	0.00082	0.00694
3.7890	31.42	1.43000	1.51000	0.00082	0.00694
4.9380	31.36	1.43000	1.51000	0.00082	0.00694
6.3200	31.42	1.43000	1.51000	0.00082	0.00694
7.5230	31.25	1.43000	1.51000	0.00082	0.00694
8.7340	31.40	1.43000	1.51000	0.00082	0.00694
10.0470	31.44	1.43000	1.51000	0.00082	0.00694
11.2580	31.33	1.43000	1.23000	0.00084	0.06476
12.4690	31.36	1.42000	1.15000	0.00104	0.14034
13.6800	31.55	1.41000	1.04000	0.00143	0.18740
14.9920	31.51	1.41000	0.94000	0.00131	0.20267
16.1480	31.69	1.41000	0.85000	0.00133	0.19573
17.2970	31.80	1.41000	0.80000	0.00170	0.15192
18.6720	32.02	1.41000	0.80000	0.00264	0.10745
19.8830	32.31	1.41000	0.81000	0.00318	0.07974
21.0940	32.33	1.41000	0.81000	0.00410	0.05912
22.4140	32.57	1.41000	0.79000	0.00528	0.04484
23.5630	32.66	1.41000	0.81000	0.00621	0.03509
24.8280	32.79	1.41000	0.81000	0.00706	0.02786
25.9840	32.92	1.41000	0.80000	0.00775	0.02354
27.3520	33.05	1.40000	0.80000	0.00838	0.02061
28.5080	32.99	1.40000	0.81000	0.00884	0.03103
29.6640	33.06	1.40000	0.81000	0.00920	0.03450
31.0310	33.19	1.40000	0.80000	0.00951	0.02872
32.2420	33.12	1.40000	0.81000	0.00968	0.02570
33.4530	33.12	1.40000	0.82000	0.00981	0.02201
34.7730	33.25	1.39000	0.81000	0.00990	0.02285
35.9840	33.34	1.39000	0.81000	0.00999	0.02836
37.1800	33.25	1.39000	0.81000	0.01012	0.03461
38.3440	33.32	1.40000	0.79000	0.01023	0.04464
39.6640	33.27	1.40000	0.81000	0.01039	0.03871
40.8590	33.19	1.40000	0.81000	0.01051	0.03945
42.0700	33.32	1.40000	0.81000	0.01061	0.04098
43.4530	33.21	1.40000	0.80000	0.01073	0.03790
44.6020	33.21	1.39000	0.81000	0.01076	0.03306
45.8130	33.25	1.39000	0.80000	0.01082	0.02875
46.9610	33.23	1.39000	0.80000	0.01081	0.04347
48.3280	33.30	1.39000	0.80000	0.01080	0.04296
49.4920	33.21	1.39000	0.80000	0.01083	0.04504
50.6410	33.36	1.39000	0.81000	0.01085	0.04765
52.0080	33.29	1.39000	0.80000	0.01089	0.10350
53.2190	33.30	1.39000	0.81000	0.01087	0.11621
54.3830	33.34	1.39000	0.81000	0.01092	0.08745
55.6880	33.18	1.39000	0.80000	0.01096	0.07002
56.8520	33.27	1.39000	0.79000	0.01099	0.06912

58.0000	33.27	1.39000	0.80000	0.01100	0.06410
59.2110	33.34	1.39000	0.80000	0.01098	0.06481
60.5310	33.30	1.39000	0.80000	0.01097	0.06268
61.7420	33.29	1.39000	0.80000	0.01098	0.05418
62.8910	33.38	1.39000	0.81000	0.01100	0.05622
64.2110	33.29	1.39000	0.80000	0.01098	0.05417
65.3590	33.36	1.39000	0.81000	0.01099	0.06521
66.5700	33.34	1.38000	0.80000	0.01099	0.06988
67.8910	33.21	1.39000	0.81000	0.01097	0.05807
69.1020	33.32	1.39000	0.79000	0.01096	0.05829
70.2970	33.36	1.39000	0.81000	0.01100	0.05204
71.4610	33.23	1.38000	0.80000	0.01104	0.05830
72.7810	33.30	1.39000	0.81000	0.01101	0.05599
74.0390	33.36	1.39000	0.81000	0.01103	0.05507
75.1880	33.25	1.39000	0.81000	0.01105	0.05618
76.5700	33.29	1.38000	0.78000	0.01108	0.05312
77.7190	33.32	1.38000	0.80000	0.01108	0.05556
78.8670	33.32	1.38000	0.80000	0.01110	0.05853
80.0780	33.45	1.38000	0.80000	0.01109	0.05328
81.4530	33.38	1.38000	0.79000	0.01109	0.05079
82.6640	33.38	1.38000	0.81000	0.01108	0.04872
83.8200	33.34	1.38000	0.82000	0.01109	0.04711
85.1880	33.54	1.38000	0.80000	0.01106	0.04338
86.3440	33.54	1.38000	0.79000	0.01109	0.03853
87.5470	33.52	1.38000	0.82000	0.01107	0.03355
88.8670	33.43	1.38000	0.82000	0.01108	0.03536
90.0780	33.50	1.38000	0.81000	0.01109	0.04057
91.2340	33.49	1.38000	0.81000	0.01107	0.04188
92.4380	33.56	1.38000	0.81000	0.01107	0.03675
93.7580	33.61	1.38000	0.80000	0.01112	0.04119
95.0230	33.65	1.38000	0.80000	0.01109	0.04012
96.1720	33.92	1.38000	0.81000	0.01110	0.04422
97.5470	33.67	1.38000	0.82000	0.01109	0.04408
98.7030	33.74	1.38000	0.81000	0.01110	0.04237
99.9610	33.76	1.38000	0.81000	0.01110	0.04067
101.2810	33.78	1.38000	0.81000	0.01111	0.03714
102.4920	33.78	1.38000	0.81000	0.01109	0.03288
103.6410	33.85	1.38000	0.81000	0.01108	0.03960
104.9140	33.92	1.38000	0.80000	0.01104	0.04199
106.1720	33.96	1.38000	0.80000	0.01102	0.04753
107.3830	33.92	1.38000	0.79000	0.01104	0.04497
108.5940	33.87	1.38000	0.81000	0.01104	0.03942
109.9610	33.96	1.38000	0.79000	0.01101	0.03812
111.1090	33.94	1.38000	0.82000	0.01105	0.03759
112.3200	33.98	1.37000	0.81000	0.01106	0.03292
113.6410	33.89	1.37000	0.80000	0.01105	0.03123
114.7890	33.96	1.37000	0.80000	0.01107	0.03730
116.0000	33.91	1.37000	0.78000	0.01105	0.04037
117.1640	33.91	1.37000	0.79000	0.01106	0.03857
118.5310	33.91	1.37000	0.78000	0.01108	0.03349
119.6800	33.96	1.37000	0.81000	0.01106	0.03496
120.8910	33.85	1.37000	0.82000	0.01106	0.03841
122.2110	33.91	1.37000	0.82000	0.01100	0.04400
123.4220	33.96	1.37000	0.80000	0.01100	0.04118
124.6170	33.87	1.37000	0.79000	0.01103	0.03841
125.7810	33.94	1.37000	0.80000	0.01104	0.03247
127.1020	33.98	1.37000	0.81000	0.01098	0.03477
128.2500	34.02	1.37000	0.80000	0.01095	0.04123
129.4610	34.14	1.37000	0.80000	0.01095	0.03883
130.7810	33.96	1.37000	0.80000	0.01096	0.04101
131.9840	34.09	1.37000	0.81000	0.01095	0.03932
133.1410	34.16	1.37000	0.82000	0.01091	0.03652
134.4610	34.05	1.37000	0.80000	0.01093	0.03628
135.6090	34.11	1.37000	0.78000	0.01095	0.03891
136.8200	34.18	1.37000	0.80000	0.01095	0.03362
137.9690	34.27	1.36000	0.81000	0.01092	0.03792



139.2890	34.27	1.37000	0.81000	0.01093	0.03917	220.2500	35.79	1.34000	0.81000	0.01066	0.02680
140.5000	34.34	1.36000	0.81000	0.01095	0.03639	221.5700	35.64	1.34000	0.82000	0.01065	0.02686
141.6480	34.33	1.37000	0.80000	0.01097	0.03407	222.7810	35.73	1.34000	0.80000	0.01063	0.02716
143.0230	34.27	1.37000	0.81000	0.01094	0.03516	223.9300	35.73	1.34000	0.81000	0.01063	0.02388
144.1800	34.27	1.37000	0.80000	0.01099	0.03172	225.2970	35.71	1.34000	0.80000	0.01067	0.02441
145.3910	34.42	1.37000	0.79000	0.01097	0.03280	226.4610	35.77	1.34000	0.80000	0.01071	0.02174
146.7030	34.40	1.37000	0.79000	0.01100	0.03485	227.6720	35.91	1.34000	0.80000	0.01066	0.02923
147.9140	34.40	1.37000	0.81000	0.01101	0.03422	228.8200	35.75	1.34000	0.80000	0.01066	0.03092
149.0700	34.51	1.36000	0.81000	0.01097	0.03740	230.1410	35.91	1.34000	0.80000	0.01069	0.04086
150.2190	34.40	1.36000	0.80000	0.01096	0.03378	231.2890	35.91	1.34000	0.81000	0.01069	0.03759
151.5940	34.58	1.36000	0.78000	0.01087	0.04344	232.4380	35.97	1.34000	0.82000	0.01064	0.04438
152.7500	34.56	1.36000	0.81000	0.01088	0.04451	233.8200	36.00	1.34000	0.82000	0.01065	0.04717
153.9610	34.53	1.36000	0.79000	0.01093	0.03842	234.9690	36.04	1.34000	0.80000	0.01065	0.05036
155.2730	34.53	1.36000	0.81000	0.01095	0.03157	236.1800	35.93	1.34000	0.81000	0.01066	0.05395
156.4840	34.67	1.36000	0.81000	0.01095	0.03204	237.3910	36.04	1.34000	0.78000	0.01062	0.05105
157.6410	34.73	1.36000	0.79000	0.01090	0.03573	238.7580	35.93	1.34000	0.79000	0.01057	0.04837
158.8440	34.76	1.36000	0.80000	0.01090	0.03432	239.9140	36.04	1.34000	0.81000	0.01054	0.04881
160.1640	34.58	1.36000	0.80000	0.01090	0.03672	241.1170	36.08	1.34000	0.81000	0.01056	0.04351
161.3670	34.71	1.36000	0.82000	0.01085	0.04689	242.4380	36.15	1.33000	0.81000	0.01057	0.04451
162.5230	34.87	1.36000	0.81000	0.01083	0.04819	243.5940	36.11	1.33000	0.80000	0.01057	0.04107
163.8440	34.82	1.36000	0.81000	0.01085	0.04463	244.7970	36.13	1.33000	0.80000	0.01059	0.03434
165.0470	34.80	1.36000	0.81000	0.01086	0.05026	246.1800	36.17	1.33000	0.79000	0.01058	0.02977
166.2580	34.89	1.35000	0.79000	0.01085	0.05546	247.3280	36.11	1.33000	0.80000	0.01061	0.02661
167.5780	34.82	1.35000	0.80000	0.01082	0.05812	248.5390	36.17	1.33000	0.79000	0.01057	0.03184
168.7810	34.87	1.35000	0.79000	0.01081	0.05401	249.7500	36.19	1.33000	0.80000	0.01054	0.03706
169.9380	34.95	1.35000	0.82000	0.01083	0.05324	251.1170	36.15	1.33000	0.79000	0.01054	0.03152
171.1480	35.02	1.36000	0.81000	0.01081	0.05422	252.2730	36.24	1.33000	0.81000	0.01057	0.03005
172.4610	34.87	1.35000	0.81000	0.01080	0.04968	253.4840	36.15	1.33000	0.81000	0.01055	0.02938
173.6170	34.98	1.36000	0.78000	0.01079	0.04518	254.7970	36.97	1.33000	0.79000	0.01056	0.02444
174.8280	35.07	1.36000	0.80000	0.01080	0.04765	256.0080	36.04	1.33000	0.80000	0.01061	0.02424
176.1480	35.00	1.35000	0.82000	0.01081	0.05554	257.1640	36.19	1.33000	0.81000	0.01056	0.02496
177.3520	35.07	1.35000	0.80000	0.01084	0.05837	258.5310	36.35	1.33000	0.78000	0.01050	0.02529
178.5080	35.04	1.35000	0.80000	0.01080	0.05392	259.6880	36.26	1.33000	0.80000	0.01050	0.02256
179.8280	35.00	1.35000	0.82000	0.01080	0.04298	260.8980	36.13	1.33000	0.79000	0.01050	0.02874
181.0310	35.02	1.35000	0.79000	0.01080	0.03998	262.0470	36.33	1.33000	0.80000	0.01051	0.02628
182.1880	37.08	1.35000	0.79000	0.01079	0.04040	263.4220	36.48	1.33000	0.81000	0.01051	0.02453
183.3980	34.95	1.35000	0.80000	0.01081	0.03593	264.5780	36.48	1.33000	0.81000	0.01053	0.02115
184.7110	35.20	1.35000	0.81000	0.01081	0.03217	265.7810	36.48	1.33000	0.79000	0.01052	0.02354
185.9220	35.02	1.35000	0.79000	0.01078	0.03210	267.1020	36.52	1.33000	0.81000	0.01052	0.02165
187.0780	35.04	1.35000	0.82000	0.01077	0.03126	268.3130	36.50	1.33000	0.82000	0.01051	0.02258
188.4530	35.15	1.35000	0.79000	0.01077	0.03055	269.5230	36.57	1.33000	0.79000	0.01051	0.02670
189.6640	35.02	1.35000	0.81000	0.01074	0.03482	270.8440	36.52	1.33000	0.79000	0.01051	0.02945
190.8130	34.98	1.35000	0.80000	0.01071	0.03770	272.0390	36.57	1.33000	0.80000	0.01048	0.03672
192.1800	35.04	1.35000	0.79000	0.01068	0.03924	273.2500	36.57	1.33000	0.81000	0.01047	0.03597
193.3440	35.20	1.35000	0.79000	0.01071	0.03703	274.4140	36.52	1.33000	0.81000	0.01048	0.03944
194.5470	35.13	1.35000	0.81000	0.01075	0.03216	275.7190	36.53	1.33000	0.81000	0.01047	0.03804
195.7030	35.20	1.35000	0.80000	0.01077	0.04369	276.9300	36.61	1.33000	0.81000	0.01048	0.03471
197.0700	35.24	1.35000	0.79000	0.01077	0.03942	278.1410	36.64	1.33000	0.82000	0.01044	0.03555
198.2810	35.22	1.35000	0.81000	0.01074	0.04635	279.4610	36.59	1.33000	0.80000	0.01047	0.03161
199.4300	35.35	1.35000	0.81000	0.01075	0.04754	280.6090	36.68	1.33000	0.79000	0.01050	0.03043
200.8130	35.31	1.35000	0.80000	0.01076	0.04672	281.8830	37.14	1.33000	0.81000	0.01052	0.02894
201.9610	35.35	1.35000	0.79000	0.01076	0.04511	283.0310	36.66	1.33000	0.81000	0.01050	0.02729
203.1720	35.44	1.35000	0.81000	0.01076	0.04538	284.3520	36.88	1.33000	0.81000	0.01048	0.02224
204.3200	35.44	1.35000	0.79000	0.01076	0.04556	285.5630	36.86	1.33000	0.80000	0.01052	0.01867
205.6880	35.38	1.35000	0.80000	0.01069	0.04587	286.7580	36.90	1.32000	0.80000	0.01055	0.02275
206.8520	35.48	1.35000	0.80000	0.01069	0.04833	288.1880	36.83	1.32000	0.80000	0.01054	0.01873
208.0000	35.44	1.34000	0.80000	0.01073	0.05179	289.3520	36.90	1.32000	0.81000	0.01053	0.01626
209.3670	35.40	1.34000	0.80000	0.01072	0.04740	290.5470	36.81	1.32000	0.80000	0.01048	0.01956
210.5310	35.33	1.34000	0.81000	0.01072	0.05154	291.8670	36.90	1.32000	0.81000	0.01048	0.01988
211.7420	35.40	1.35000	0.80000	0.01071	0.05014	293.0310	36.99	1.32000	0.80000	0.01044	0.01967
213.0470	35.38	1.34000	0.81000	0.01073	0.04755	294.2340	36.99	1.32000	0.81000	0.01043	0.02006
214.2580	35.49	1.34000	0.80000	0.01074	0.04144	295.4380	37.01	1.32000	0.80000	0.01047	0.01984
215.4220	35.51	1.34000	0.80000	0.01074	0.03617	296.7110	36.97	1.32000	0.82000	0.01050	0.02697
216.6330	35.51	1.34000	0.80000	0.01068	0.04202	297.9140	37.06	1.32000	0.81000	0.01047	0.03171
217.8910	35.66	1.34000	0.82000	0.01066	0.03540	299.0700	37.06	1.32000	0.81000	0.01051	0.02565
219.1020	35.35	1.34000	0.79000	0.01067	0.03092	300.3910	37.10	1.32000	0.81000	0.01050	0.02079



301.5940	37.19	1.32000	0.81000	0.01046	0.02322	383.1640	38.45	1.30000	0.81000	0.01015	0.02763
302.7500	37.10	1.32000	0.82000	0.01046	0.02321	384.3130	38.51	1.30000	0.81000	0.01015	0.02817
304.1170	37.21	1.32000	0.81000	0.01045	0.02280	385.5230	38.43	1.30000	0.79000	0.01012	0.02570
305.2730	37.10	1.32000	0.80000	0.01039	0.02193	386.6720	38.56	1.30000	0.79000	0.01011	0.02196
306.4840	37.30	1.32000	0.80000	0.01039	0.02450	387.9920	34.87	1.30000	0.81000	0.01006	0.02188
307.6410	37.26	1.32000	0.80000	0.01038	0.02213	389.2030	38.52	1.30000	0.82000	0.01010	0.02668
309.0080	37.32	1.32000	0.80000	0.01039	0.02506	390.4140	38.56	1.30000	0.81000	0.01006	0.02757
310.2190	37.28	1.32000	0.79000	0.01038	0.02145	391.7340	38.56	1.30000	0.80000	0.01006	0.02807
311.4300	37.23	1.32000	0.81000	0.01036	0.02089	392.9380	38.60	1.30000	0.82000	0.01005	0.02469
312.7970	37.34	1.31000	0.81000	0.01040	0.02243	394.0940	38.65	1.30000	0.81000	0.01008	0.02175
313.9530	37.28	1.31000	0.80000	0.01038	0.02529	395.3520	38.69	1.30000	0.82000	0.01009	0.01981
315.1640	37.26	1.31000	0.81000	0.01039	0.02372	396.6720	38.71	1.30000	0.80000	0.01006	0.02377
316.3670	37.43	1.31000	0.79000	0.01039	0.02741	397.8200	38.65	1.30000	0.81000	0.01003	0.03099
317.7420	37.39	1.31000	0.79000	0.01038	0.02961	398.9840	38.63	1.30000	0.80000	0.01007	0.03226
318.9530	37.48	1.31000	0.80000	0.01033	0.02525	400.3520	38.69	1.29000	0.81000	0.01008	0.02968
320.1020	37.12	1.31000	0.82000	0.01035	0.02243	401.5000	38.78	1.29000	0.81000	0.01009	0.02641
321.4220	37.43	1.32000	0.81000	0.01033	0.02747	402.7730	38.71	1.29000	0.81000	0.01007	0.02558
322.6330	37.54	1.31000	0.81000	0.01032	0.02387	404.0940	38.80	1.29000	0.80000	0.01004	0.03008
323.8440	37.48	1.31000	0.80000	0.01031	0.03405	405.2890	38.83	1.29000	0.82000	0.01006	0.03188
325.1640	37.56	1.31000	0.80000	0.01032	0.03446	406.4530	38.85	1.29000	0.81000	0.01003	0.03252
326.3130	37.48	1.31000	0.81000	0.01027	0.04190	407.7110	38.80	1.29000	0.79000	0.01006	0.03352
327.5230	37.56	1.31000	0.80000	0.01026	0.05909	408.9690	38.80	1.29000	0.81000	0.01007	0.03022
328.7340	37.63	1.31000	0.80000	0.01023	0.06353	410.1800	38.76	1.29000	0.81000	0.01005	0.03039
330.0470	37.63	1.31000	0.79000	0.01024	0.04926	411.3440	38.91	1.29000	0.79000	0.01007	0.02612
331.2500	37.74	1.31000	0.81000	0.01025	0.03836	412.7110	38.83	1.29000	0.80000	0.01006	0.02509
332.4610	37.67	1.31000	0.81000	0.01022	0.03581	413.8590	38.94	1.29000	0.80000	0.01004	0.02393
333.7810	37.74	1.31000	0.82000	0.01021	0.03194	415.0230	38.91	1.29000	0.80000	0.01004	0.02211
334.9920	37.67	1.31000	0.82000	0.01023	0.03015	416.3280	39.00	1.29000	0.80000	0.01004	0.02095
336.1410	37.74	1.31000	0.81000	0.01028	0.02578	417.4920	38.89	1.29000	0.81000	0.00999	0.02476
337.4610	38.21	1.31000	0.80000	0.01027	0.02335	418.7030	39.05	1.29000	0.81000	0.01001	0.02351
338.6720	37.76	1.31000	0.80000	0.01029	0.02500	419.8520	38.96	1.29000	0.81000	0.00998	0.01947
339.8200	37.85	1.31000	0.79000	0.01029	0.02770	421.1720	39.02	1.29000	0.80000	0.00998	0.02111
341.0940	37.94	1.31000	0.80000	0.01031	0.03219	422.3200	39.18	1.29000	0.81000	0.00997	0.02104
342.3980	37.76	1.31000	0.81000	0.01028	0.03281	423.5310	39.09	1.28000	0.80000	0.00997	0.02039
343.6090	37.85	1.31000	0.81000	0.01029	0.03183	424.8520	39.07	1.29000	0.80000	0.00996	0.02015
344.7730	37.85	1.31000	0.81000	0.01027	0.02977	426.0630	36.38	1.29000	0.80000	0.00994	0.01946
346.0780	37.92	1.31000	0.79000	0.01021	0.02782	427.2110	39.14	1.29000	0.81000	0.00995	0.01657
347.2420	37.90	1.30000	0.81000	0.01025	0.02827	428.5780	39.18	1.28000	0.80000	0.00994	0.01888
348.3910	37.90	1.30000	0.80000	0.01023	0.03201	429.7420	39.16	1.28000	0.80000	0.00994	0.01740
349.7580	37.90	1.30000	0.81000	0.01021	0.03445	430.8910	39.14	1.29000	0.81000	0.00991	0.01691
350.9220	38.03	1.30000	0.82000	0.01019	0.03187	432.1020	39.29	1.29000	0.80000	0.00995	0.02080
352.1800	38.01	1.30000	0.81000	0.01014	0.03268	433.4690	39.22	1.28000	0.80000	0.00996	0.01967
353.3280	37.96	1.30000	0.82000	0.01016	0.02908	434.6800	39.34	1.29000	0.80000	0.00996	0.02054
354.7110	38.01	1.30000	0.81000	0.01022	0.02952	435.8280	39.38	1.28000	0.82000	0.00993	0.02032
355.8590	38.07	1.30000	0.80000	0.01020	0.02504	437.2110	39.45	1.28000	0.81000	0.00985	0.02074
357.1170	37.99	1.30000	0.80000	0.01021	0.02665	438.3590	39.36	1.28000	0.81000	0.00986	0.01951
358.4380	38.01	1.30000	0.80000	0.01016	0.03028	439.5700	39.31	1.28000	0.80000	0.00986	0.02234
359.6480	38.21	1.31000	0.81000	0.01018	0.02858	440.7190	39.49	1.28000	0.79000	0.00984	0.02396
360.7970	38.07	1.30000	0.81000	0.01019	0.03022	442.0940	39.31	1.28000	0.81000	0.00983	0.02365
361.9610	38.14	1.30000	0.79000	0.01018	0.03127	443.2970	39.29	1.28000	0.80000	0.00984	0.02312
363.3280	38.16	1.30000	0.81000	0.01020	0.02721	444.4610	39.31	1.28000	0.80000	0.00981	0.02243
364.5390	38.23	1.30000	0.80000	0.01022	0.02312	445.7730	39.29	1.28000	0.80000	0.00980	0.02257
365.7500	38.18	1.30000	0.80000	0.01019	0.02016	446.9300	39.40	1.28000	0.80000	0.00982	0.02117
367.0700	38.23	1.30000	0.80000	0.01017	0.02067	448.1410	38.16	1.28000	0.82000	0.00983	0.01931
368.2190	38.05	1.30000	0.82000	0.01017	0.01961	449.5080	39.33	1.28000	0.81000	0.00981	0.01894
369.4300	38.21	1.30000	0.80000	0.01013	0.02103	450.6640	39.42	1.28000	0.81000	0.00984	0.02212
370.7500	38.21	1.30000	0.79000	0.01011	0.02218	451.8200	39.49	1.28000	0.81000	0.00987	0.01986
371.8980	38.32	1.30000	0.80000	0.01011	0.02054	453.0230	39.42	1.28000	0.79000	0.00984	0.01798
373.1640	38.38	1.30000	0.80000	0.01015	0.01981	454.3440	39.22	1.28000	0.80000	0.00985	0.01968
374.3200	38.63	1.30000	0.80000	0.01014	0.02339	455.5470	39.49	1.28000	0.81000	0.00983	0.01949
375.6880	38.27	1.30000	0.82000	0.01012	0.02270	456.7030	39.62	1.28000	0.81000	0.00986	0.01858
376.8440	38.32	1.30000	0.81000	0.01012	0.02339	458.0780	39.53	1.28000	0.80000	0.00987	0.01662
378.1090	38.34	1.30000	0.80000	0.01016	0.02623	459.2340	39.62	1.28000	0.80000	0.00986	0.01557
379.4220	38.29	1.30000	0.80000	0.01016	0.02658	460.4380	39.75	1.28000	0.81000	0.00989	0.01753
380.6330	38.30	1.30000	0.79000	0.01017	0.02790	461.7580	40.29	1.28000	0.79000	0.00990	0.01889
381.7890	38.45	1.30000	0.81000	0.01015	0.02483	462.9690	39.67	1.28000	0.79000	0.00992	0.01679

464.1170	39.58	1.28000	0.81000	0.00990	0.02033	545.5230	40.82	1.26000	0.81000	0.00958	0.01721
465.3280	39.18	1.28000	0.82000	0.00986	0.02090	546.6720	40.88	1.26000	0.81000	0.00953	0.01691
466.6480	39.82	1.28000	0.81000	0.00988	0.02374	547.8830	40.86	1.26000	0.81000	0.00954	0.01600
467.8520	39.80	1.28000	0.81000	0.00986	0.02741	549.1410	41.10	1.26000	0.81000	0.00953	0.02004
469.0080	39.89	1.28000	0.79000	0.00985	0.02360	550.3520	40.88	1.26000	0.80000	0.00951	0.01955
470.3280	39.80	1.28000	0.81000	0.00983	0.02054	551.5080	40.99	1.26000	0.80000	0.00956	0.01798
471.5310	39.84	1.28000	0.81000	0.00982	0.02278	552.7110	40.93	1.26000	0.81000	0.00957	0.01620
472.6880	39.84	1.27000	0.80000	0.00981	0.02064	554.0310	40.97	1.26000	0.81000	0.00957	0.01523
473.8440	39.91	1.27000	0.81000	0.00979	0.02105	555.2420	40.90	1.26000	0.81000	0.00956	0.01300
475.1640	39.84	1.27000	0.81000	0.00974	0.02056	556.3910	41.08	1.26000	0.81000	0.00955	0.01540
476.3670	39.91	1.27000	0.80000	0.00973	0.01937	557.7110	41.10	1.26000	0.81000	0.00955	0.01827
477.5230	39.91	1.27000	0.79000	0.00976	0.02003	558.8670	41.10	1.25000	0.81000	0.00958	0.01704
478.8910	39.98	1.27000	0.81000	0.00977	0.01922	560.0230	41.08	1.26000	0.80000	0.00954	0.01520
480.0470	40.02	1.27000	0.80000	0.00975	0.01991	561.3910	41.17	1.25000	0.80000	0.00950	0.01551
481.2580	39.95	1.27000	0.81000	0.00975	0.02678	562.4920	41.13	1.25000	0.81000	0.00949	0.01406
482.5700	40.06	1.28000	0.80000	0.00972	0.02618	563.7030	41.17	1.25000	0.80000	0.00950	0.01463
483.7810	40.04	1.27000	0.80000	0.00972	0.02611	564.8520	41.17	1.26000	0.79000	0.00954	0.01589
484.9380	40.11	1.27000	0.80000	0.00972	0.02393	566.1720	41.17	1.25000	0.80000	0.00953	0.01708
486.2030	40.00	1.27000	0.81000	0.00975	0.01943	567.3830	41.15	1.26000	0.81000	0.00956	0.01431
487.5230	40.13	1.27000	0.79000	0.00973	0.01753	568.5940	41.24	1.26000	0.81000	0.00956	0.01589
488.7340	40.15	1.27000	0.79000	0.00971	0.01908	569.9140	41.19	1.26000	0.81000	0.00961	0.01515
489.8830	40.09	1.27000	0.80000	0.00975	0.01705	571.1090	41.24	1.25000	0.80000	0.00957	0.01712
491.2030	40.09	1.27000	0.79000	0.00975	0.01546	572.2730	41.35	1.25000	0.80000	0.00952	0.01867
492.4140	40.13	1.27000	0.81000	0.00976	0.01408	573.6410	41.35	1.25000	0.81000	0.00951	0.01799
493.6090	40.15	1.27000	0.81000	0.00975	0.01553	574.7890	41.32	1.25000	0.81000	0.00953	0.01610
494.9300	40.13	1.27000	0.79000	0.00973	0.01646	576.0000	41.41	1.25000	0.81000	0.00954	0.01785
496.1410	40.15	1.27000	0.81000	0.00974	0.01585	577.1640	41.44	1.25000	0.81000	0.00950	0.01660
497.2890	40.18	1.27000	0.82000	0.00971	0.02199	578.4690	41.48	1.25000	0.81000	0.00944	0.01911
498.5000	40.20	1.27000	0.81000	0.00971	0.01950	579.6800	41.46	1.25000	0.80000	0.00945	0.02546
499.8200	40.24	1.26000	0.81000	0.00966	0.02292	580.8440	41.50	1.25000	0.81000	0.00949	0.02220
501.0310	40.20	1.26000	0.81000	0.00963	0.02079	582.2110	44.70	1.25000	0.81000	0.00946	0.02349
502.1800	40.17	1.27000	0.79000	0.00963	0.02052	583.3590	41.52	1.25000	0.81000	0.00942	0.02105
503.5630	40.29	1.26000	0.81000	0.00963	0.01795	584.5700	41.57	1.25000	0.80000	0.00941	0.01998
504.7110	40.00	1.26000	0.80000	0.00964	0.01711	585.8910	41.48	1.25000	0.80000	0.00943	0.02101
505.9220	39.71	1.26000	0.81000	0.00963	0.01807	587.1020	41.55	1.25000	0.81000	0.00941	0.02044
507.2420	40.35	1.26000	0.80000	0.00962	0.01681	588.3130	39.36	1.25000	0.81000	0.00942	0.02302
508.4380	40.29	1.27000	0.81000	0.00963	0.01790	589.5080	41.57	1.25000	0.80000	0.00943	0.02310
509.6480	40.42	1.26000	0.81000	0.00963	0.01838	590.8280	41.55	1.25000	0.81000	0.00941	0.02157
510.8130	40.44	1.27000	0.81000	0.00965	0.01891	591.9920	41.52	1.25000	0.80000	0.00941	0.01880
512.1800	40.46	1.26000	0.80000	0.00964	0.02139	593.2500	41.61	1.24000	0.81000	0.00941	0.01607
513.3280	40.33	1.26000	0.82000	0.00963	0.01878	594.5700	41.72	1.25000	0.81000	0.00941	0.01687
514.6020	40.48	1.27000	0.80000	0.00968	0.02040	595.7810	41.64	1.24000	0.80000	0.00944	0.01794
515.8590	40.53	1.26000	0.80000	0.00965	0.01969	596.9300	41.61	1.24000	0.81000	0.00946	0.01767
517.1170	40.44	1.26000	0.81000	0.00971	0.01852	598.1880	41.72	1.24000	0.81000	0.00941	0.01801
518.2810	40.60	1.26000	0.81000	0.00970	0.01941	599.5080	41.72	1.24000	0.81000	0.00940	0.01901
519.4300	40.53	1.26000	0.80000	0.00965	0.01709	600.6640	39.89	1.24000	0.79000	0.00941	0.01978
520.7970	40.62	1.26000	0.79000	0.00965	0.01490	601.8200	41.81	1.24000	0.80000	0.00941	0.02222
522.0080	40.60	1.26000	0.79000	0.00970	0.01782	603.1880	41.79	1.24000	0.80000	0.00941	0.02032
523.2190	40.60	1.26000	0.81000	0.00970	0.01700	604.3440	41.84	1.24000	0.81000	0.00939	0.01961
524.5390	40.62	1.26000	0.79000	0.00966	0.01771	605.5000	41.81	1.24000	0.80000	0.00935	0.02109
525.7500	40.59	1.26000	0.81000	0.00961	0.01690	606.8670	41.81	1.24000	0.81000	0.00931	0.01974
526.9530	40.66	1.26000	0.81000	0.00960	0.01416	608.0780	41.97	1.24000	0.79000	0.00932	0.01901
528.2730	40.68	1.26000	0.79000	0.00964	0.01339	609.2890	41.86	1.24000	0.81000	0.00931	0.02126
529.4840	40.73	1.26000	0.81000	0.00960	0.01325	610.4380	41.94	1.24000	0.82000	0.00930	0.02702
530.6330	40.79	1.26000	0.80000	0.00961	0.01318	611.7580	41.97	1.24000	0.81000	0.00931	0.02957
531.7890	40.71	1.26000	0.79000	0.00963	0.01419	612.9140	41.26	1.24000	0.81000	0.00933	0.02987
533.1640	40.75	1.26000	0.81000	0.00961	0.01605	614.1170	41.79	1.24000	0.80000	0.00933	0.02863
534.3670	40.73	1.26000	0.81000	0.00963	0.01723	615.4920	41.92	1.24000	0.81000	0.00935	0.02520
535.5780	41.01	1.26000	0.81000	0.00962	0.01586	616.6480	41.94	1.24000	0.80000	0.00934	0.02850
536.8980	40.66	1.26000	0.81000	0.00962	0.01930	617.7970	41.97	1.24000	0.79000	0.00933	0.02795
538.1020	40.64	1.26000	0.81000	0.00960	0.01956	619.1720	42.03	1.24000	0.79000	0.00933	0.02451
539.3130	40.88	1.26000	0.81000	0.00958	0.02164	620.3830	42.30	1.24000	0.81000	0.00933	0.02098
540.5780	40.82	1.26000	0.80000	0.00958	0.02212	621.5390	42.10	1.24000	0.81000	0.00928	0.01821
541.7340	40.86	1.26000	0.81000	0.00959	0.02292	622.7420	42.08	1.24000	0.81000	0.00928	0.01853
542.9920	40.88	1.26000	0.81000	0.00960	0.01860	624.0630	42.08	1.24000	0.81000	0.00928	0.01795
544.1480	40.86	1.26000	0.80000	0.00960	0.01771	625.2730	41.92	1.24000	0.80000	0.00928	0.01715

626.4220	42.19	1.24000	0.81000	0.00926	0.01787	707.7730	42.94	1.22000	0.81000	0.00905	0.01623
627.7970	42.10	1.24000	0.81000	0.00927	0.01775	708.9840	43.14	1.22000	0.80000	0.00905	0.01886
629.0080	42.17	1.24000	0.81000	0.00925	0.01869	710.1330	43.18	1.22000	0.81000	0.00909	0.01661
630.1640	42.10	1.24000	0.81000	0.00926	0.01803	711.5000	43.18	1.22000	0.81000	0.00910	0.01643
631.3670	42.17	1.24000	0.81000	0.00925	0.01801	712.6020	43.18	1.22000	0.81000	0.00910	0.01729
632.6880	42.30	1.24000	0.80000	0.00929	0.01611	713.8130	43.18	1.22000	0.79000	0.00908	0.01856
633.8910	42.19	1.24000	0.81000	0.00926	0.01912	715.1330	43.36	1.22000	0.81000	0.00905	0.01616
635.0470	42.21	1.24000	0.79000	0.00924	0.01994	716.3440	43.40	1.22000	0.80000	0.00905	0.01774
636.4220	42.21	1.24000	0.81000	0.00926	0.02088	717.4920	41.48	1.22000	0.81000	0.00906	0.02052
637.6330	42.23	1.24000	0.81000	0.00925	0.01871	718.8130	43.38	1.22000	0.80000	0.00903	0.01808
638.7810	42.25	1.24000	0.80000	0.00928	0.01937	720.0230	43.32	1.22000	0.81000	0.00901	0.01745
640.1640	42.23	1.23000	0.81000	0.00923	0.02309	721.1720	43.29	1.21000	0.81000	0.00901	0.02063
641.3130	42.30	1.24000	0.81000	0.00924	0.02803	722.4300	43.40	1.22000	0.81000	0.00899	0.01912
642.5700	42.30	1.24000	0.80000	0.00921	0.02489	723.7500	43.36	1.22000	0.81000	0.00897	0.01706
643.7340	42.30	1.24000	0.80000	0.00919	0.02274	724.9610	43.32	1.21000	0.81000	0.00896	0.01928
645.1020	42.39	1.23000	0.81000	0.00918	0.02483	726.1090	43.40	1.22000	0.79000	0.00898	0.01856
646.2500	42.32	1.23000	0.80000	0.00921	0.02485	727.4920	43.38	1.22000	0.81000	0.00898	0.01876
647.4140	42.30	1.23000	0.81000	0.00922	0.02505	728.7030	43.45	1.22000	0.81000	0.00897	0.01638
648.7190	42.34	1.23000	0.81000	0.00920	0.02103	729.8520	43.54	1.21000	0.80000	0.00895	0.01853
649.8830	42.25	1.23000	0.80000	0.00916	0.02315	731.1720	43.54	1.21000	0.80000	0.00895	0.01811
651.0940	42.41	1.23000	0.80000	0.00916	0.02195	732.3830	43.52	1.21000	0.81000	0.00894	0.01709
652.3980	42.41	1.23000	0.81000	0.00915	0.02585	733.5310	43.54	1.21000	0.80000	0.00893	0.01565
653.6090	42.45	1.23000	0.79000	0.00913	0.02359	734.7420	43.56	1.21000	0.80000	0.00892	0.01482
654.7730	42.28	1.23000	0.80000	0.00916	0.02562	736.1090	43.47	1.21000	0.81000	0.00893	0.01481
655.9690	42.48	1.23000	0.80000	0.00917	0.02517	737.2580	43.56	1.21000	0.81000	0.00890	0.01477
657.2420	42.25	1.23000	0.80000	0.00916	0.02341	738.4220	43.54	1.21000	0.81000	0.00893	0.01608
658.5000	42.52	1.23000	0.80000	0.00914	0.02593	739.7890	43.58	1.21000	0.80000	0.00894	0.01669
659.6480	42.39	1.23000	0.81000	0.00912	0.02647	740.9380	43.45	1.22000	0.81000	0.00896	0.01487
660.9690	42.50	1.23000	0.80000	0.00914	0.02421	742.1480	43.58	1.21000	0.81000	0.00894	0.01459
662.1800	42.48	1.23000	0.81000	0.00915	0.02351	743.4690	43.60	1.21000	0.81000	0.00894	0.01483
663.3910	42.52	1.23000	0.80000	0.00913	0.02565	744.6800	43.49	1.21000	0.80000	0.00889	0.01550
664.7110	42.54	1.23000	0.81000	0.00918	0.02211	745.8280	43.56	1.21000	0.80000	0.00889	0.01623
665.9220	42.54	1.23000	0.81000	0.00919	0.02077	747.0390	43.54	1.21000	0.80000	0.00890	0.01688
667.0700	42.63	1.23000	0.80000	0.00918	0.02045	748.3590	43.54	1.21000	0.81000	0.00886	0.01826
668.2810	42.50	1.23000	0.81000	0.00919	0.02850	749.5700	43.65	1.21000	0.81000	0.00892	0.01729
669.6020	42.63	1.23000	0.81000	0.00920	0.02839	750.7190	43.63	1.21000	0.81000	0.00894	0.01805
670.7500	42.65	1.23000	0.80000	0.00919	0.03109	752.0940	43.63	1.21000	0.80000	0.00895	0.01806
672.0080	42.85	1.23000	0.80000	0.00916	0.02945	753.2970	43.63	1.21000	0.80000	0.00893	0.01752
673.3280	42.65	1.23000	0.81000	0.00917	0.02490	754.4610	43.65	1.21000	0.81000	0.00889	0.01667
674.5390	42.65	1.23000	0.80000	0.00920	0.02348	755.6640	43.69	1.21000	0.81000	0.00891	0.01848
675.6880	42.67	1.23000	0.80000	0.00922	0.02235	756.9840	43.67	1.21000	0.80000	0.00895	0.01677
676.8980	42.81	1.23000	0.81000	0.00922	0.02180	758.1880	43.69	1.21000	0.80000	0.00894	0.01692
678.2190	42.70	1.23000	0.81000	0.00923	0.01945	759.3440	43.76	1.21000	0.81000	0.00893	0.01577
679.4300	42.98	1.23000	0.80000	0.00921	0.01865	760.7190	43.71	1.21000	0.81000	0.00893	0.01534
680.5780	44.16	1.23000	0.80000	0.00920	0.01910	761.9300	43.67	1.21000	0.81000	0.00892	0.01377
681.8980	42.85	1.23000	0.80000	0.00917	0.02917	763.1880	43.85	1.21000	0.80000	0.00888	0.01475
683.1090	42.81	1.22000	0.81000	0.00921	0.02518	764.5080	43.74	1.21000	0.81000	0.00888	0.01507
684.2580	42.76	1.23000	0.80000	0.00920	0.02468	765.7190	43.85	1.21000	0.81000	0.00884	0.01577
685.6330	42.85	1.23000	0.81000	0.00915	0.02216	766.8670	43.87	1.21000	0.81000	0.00885	0.01688
686.7890	42.83	1.22000	0.81000	0.00914	0.02367	768.0780	43.85	1.21000	0.81000	0.00885	0.01602
688.0000	42.83	1.22000	0.81000	0.00907	0.02282	769.3980	43.82	1.21000	0.80000	0.00882	0.01668
689.1480	42.78	1.22000	0.81000	0.00906	0.02320	770.6020	43.78	1.21000	0.81000	0.00883	0.01638
690.5230	42.98	1.22000	0.80000	0.00908	0.02172	771.7580	43.80	1.21000	0.81000	0.00885	0.01675
691.7340	42.87	1.22000	0.81000	0.00908	0.02312	773.0780	43.87	1.21000	0.81000	0.00881	0.01886
692.8830	42.81	1.22000	0.81000	0.00907	0.02272	774.2810	43.83	1.21000	0.80000	0.00882	0.01884
694.2580	42.89	1.22000	0.80000	0.00907	0.02226	775.4380	43.94	1.21000	0.82000	0.00877	0.01757
695.4140	42.85	1.22000	0.80000	0.00910	0.02091	776.8130	43.85	1.21000	0.80000	0.00878	0.01998
696.6170	42.98	1.22000	0.81000	0.00906	0.01984	777.9610	43.85	1.20000	0.81000	0.00878	0.02371
697.9380	42.92	1.22000	0.82000	0.00908	0.01869	779.1720	43.89	1.20000	0.81000	0.00885	0.02133
699.1480	42.98	1.22000	0.80000	0.00905	0.01756	780.3280	44.02	1.20000	0.81000	0.00883	0.02088
700.3520	43.03	1.22000	0.81000	0.00902	0.01699	781.6410	44.02	1.20000	0.81000	0.00883	0.02078
701.6170	43.05	1.22000	0.81000	0.00904	0.01791	782.8520	43.91	1.21000	0.79000	0.00881	0.02067
702.8830	42.92	1.22000	0.81000	0.00902	0.01798	784.0080	44.07	1.21000	0.81000	0.00879	0.01930
704.0940	42.89	1.22000	0.79000	0.00903	0.02018	785.3830	44.13	1.20000	0.80000	0.00880	0.01906
705.2420	43.05	1.22000	0.80000	0.00902	0.02060	786.5940	44.18	1.20000	0.81000	0.00879	0.01591
706.6170	43.01	1.22000	0.81000	0.00903	0.01755	787.7970	44.20	1.21000	0.80000	0.00876	0.02132

788.9530	44.18	1.20000	0.81000	0.00876	0.02225	870.2890	45.40	1.19000	0.80000	0.00857	0.01738
790.2730	44.20	1.21000	0.80000	0.00880	0.02144	871.4530	45.20	1.19000	0.81000	0.00858	0.01707
791.4840	44.09	1.20000	0.81000	0.00879	0.02147	872.8200	45.31	1.19000	0.79000	0.00858	0.01849
792.6330	44.22	1.20000	0.80000	0.00883	0.01912	873.9690	45.24	1.19000	0.80000	0.00860	0.01921
794.0000	44.27	1.20000	0.80000	0.00880	0.01933	875.1800	45.44	1.19000	0.79000	0.00862	0.02227
795.1640	44.27	1.20000	0.81000	0.00880	0.01654	876.5000	45.40	1.19000	0.81000	0.00860	0.01981
796.3590	44.27	1.20000	0.80000	0.00885	0.01910	877.7110	45.42	1.19000	0.80000	0.00860	0.01716
797.6800	44.40	1.20000	0.81000	0.00881	0.01618	878.9220	45.46	1.19000	0.80000	0.00857	0.01505
798.8440	44.31	1.20000	0.81000	0.00883	0.01625	880.0700	45.46	1.19000	0.80000	0.00858	0.01460
800.0390	44.29	1.20000	0.80000	0.00882	0.01764	881.4380	45.26	1.19000	0.80000	0.00859	0.01493
801.2030	44.33	1.20000	0.81000	0.00881	0.02063	882.6020	45.37	1.19000	0.81000	0.00855	0.01822
802.5700	44.31	1.20000	0.81000	0.00881	0.01895	883.8130	46.48	1.18000	0.81000	0.00857	0.01874
803.7190	44.38	1.20000	0.81000	0.00880	0.01685	885.1170	44.71	1.18000	0.81000	0.00858	0.02040
804.9300	44.31	1.20000	0.81000	0.00878	0.01443	886.3280	45.31	1.19000	0.80000	0.00859	0.02005
806.2030	44.53	1.20000	0.81000	0.00877	0.01557	887.4920	45.57	1.19000	0.80000	0.00857	0.01722
807.3980	44.53	1.20000	0.81000	0.00875	0.01418	888.7970	45.51	1.19000	0.81000	0.00860	0.01880
808.5630	44.51	1.20000	0.81000	0.00874	0.01330	890.0080	45.51	1.18000	0.81000	0.00856	0.01606
809.9300	44.53	1.20000	0.80000	0.00873	0.01328	891.1720	45.68	1.18000	0.81000	0.00856	0.01626
811.0780	44.56	1.20000	0.81000	0.00874	0.01211	892.3670	45.53	1.18000	0.79000	0.00856	0.01917
812.2420	44.73	1.20000	0.81000	0.00872	0.01500	893.6880	45.60	1.18000	0.81000	0.00853	0.01773
813.4530	44.58	1.20000	0.81000	0.00873	0.01307	894.9530	45.66	1.19000	0.81000	0.00854	0.01742
814.7580	44.56	1.20000	0.82000	0.00872	0.01307	896.1090	45.62	1.18000	0.80000	0.00853	0.01573
815.9690	44.55	1.20000	0.81000	0.00869	0.01610	897.4840	45.62	1.18000	0.84000	0.00854	0.01416
817.1330	44.58	1.20000	0.81000	0.00863	0.01665	898.6330	45.68	1.18000	0.80000	0.00852	0.01388
818.5000	44.67	1.20000	0.81000	0.00865	0.01574	899.7890	47.04	1.18000	0.80000	0.00858	0.01394
819.7110	44.73	1.20000	0.80000	0.00867	0.01499	901.1640	45.59	1.18000	0.81000	0.00857	0.01244
820.8590	44.71	1.20000	0.81000	0.00871	0.01462	902.3670	45.59	1.18000	0.81000	0.00856	0.01291
822.2340	44.78	1.20000	0.81000	0.00874	0.01406	903.5230	45.66	1.18000	0.80000	0.00851	0.01310
823.3910	44.82	1.19000	0.80000	0.00873	0.01532	904.6800	45.66	1.18000	0.81000	0.00853	0.01512
824.6020	44.82	1.20000	0.79000	0.00871	0.01898	906.0470	45.73	1.18000	0.81000	0.00854	0.01536
825.7500	44.80	1.20000	0.80000	0.00874	0.02109	907.2030	45.57	1.18000	0.80000	0.00851	0.01763
827.1170	44.84	1.20000	0.81000	0.00869	0.01929	908.4140	45.68	1.18000	0.80000	0.00849	0.01903
828.3280	44.80	1.19000	0.80000	0.00869	0.02049	909.7340	45.79	1.18000	0.81000	0.00851	0.01827
829.5390	44.75	1.19000	0.81000	0.00864	0.01842	910.9380	45.75	1.18000	0.80000	0.00848	0.01824
830.8590	44.84	1.19000	0.80000	0.00863	0.01768	912.0940	46.13	1.18000	0.80000	0.00845	0.01600
832.0700	44.55	1.19000	0.80000	0.00863	0.01874	913.2970	45.71	1.18000	0.80000	0.00844	0.01473
833.2190	44.82	1.19000	0.80000	0.00867	0.01817	914.6170	45.73	1.18000	0.81000	0.00845	0.01322
834.3670	44.89	1.20000	0.80000	0.00864	0.01985	915.8280	45.86	1.18000	0.81000	0.00846	0.01747
835.7500	45.04	1.20000	0.80000	0.00871	0.02006	916.9840	45.88	1.18000	0.81000	0.00844	0.01582
836.8980	44.64	1.20000	0.80000	0.00872	0.01893	918.3520	45.86	1.18000	0.81000	0.00841	0.01553
838.1090	44.95	1.19000	0.81000	0.00871	0.01867	919.5080	45.79	1.18000	0.80000	0.00845	0.01530
839.4300	44.95	1.19000	0.80000	0.00871	0.01940	920.7110	45.86	1.18000	0.80000	0.00851	0.01597
840.6880	44.98	1.19000	0.81000	0.00868	0.01727	921.9840	45.86	1.18000	0.80000	0.00848	0.01518
841.8980	44.91	1.19000	0.81000	0.00871	0.01772	923.2420	45.97	1.18000	0.80000	0.00846	0.01577
843.2730	45.00	1.19000	0.81000	0.00867	0.01743	924.3910	45.90	1.18000	0.80000	0.00844	0.01458
844.4220	45.04	1.19000	0.81000	0.00864	0.01573	925.5470	45.97	1.18000	0.81000	0.00843	0.01249
845.6330	45.04	1.19000	0.81000	0.00864	0.01367	926.9220	45.88	1.18000	0.81000	0.00837	0.01507
846.8440	45.00	1.19000	0.81000	0.00863	0.01391	928.1330	45.95	1.18000	0.81000	0.00838	0.01526
848.1640	45.04	1.19000	0.79000	0.00865	0.01561	929.2810	45.93	1.18000	0.83000	0.00839	0.01359
849.3130	45.11	1.19000	0.80000	0.00863	0.01458	930.6020	45.95	1.18000	0.81000	0.00841	0.01484
850.4690	45.02	1.20000	0.81000	0.00863	0.01428	931.8130	46.02	1.17000	0.81000	0.00839	0.01542
851.8440	45.00	1.19000	0.81000	0.00864	0.01443	932.9610	45.99	1.17000	0.81000	0.00836	0.01549
852.9920	45.00	1.19000	0.80000	0.00864	0.01580	934.3440	46.02	1.18000	0.80000	0.00833	0.01421
854.2580	45.17	1.19000	0.81000	0.00862	0.01628	935.4920	46.46	1.17000	0.81000	0.00834	0.01408
855.5700	45.06	1.19000	0.80000	0.00860	0.01462	936.7030	46.10	1.18000	0.80000	0.00834	0.01477
856.7810	45.13	1.19000	0.81000	0.00861	0.01424	937.8520	46.21	1.18000	0.80000	0.00839	0.01641
857.9380	45.20	1.19000	0.81000	0.00859	0.01530	939.1720	46.15	1.18000	0.80000	0.00838	0.01789
859.1410	45.11	1.19000	0.81000	0.00858	0.01604	940.4300	44.78	1.18000	0.80000	0.00840	0.01627
860.5230	45.06	1.19000	0.80000	0.00855	0.01522	941.5940	46.15	1.18000	0.81000	0.00839	0.01575
861.6720	45.24	1.19000	0.81000	0.00855	0.01457	942.9610	46.13	1.18000	0.80000	0.00840	0.01440
862.8830	45.20	1.19000	0.81000	0.00861	0.01630	944.1090	46.28	1.18000	0.81000	0.00833	0.01378
864.2030	45.15	1.18000	0.80000	0.00862	0.02067	945.3200	46.21	1.17000	0.81000	0.00834	0.01366
865.3520	45.22	1.18000	0.81000	0.00860	0.02047	946.4840	46.28	1.17000	0.81000	0.00834	0.01292
866.5630	45.35	1.19000	0.80000	0.00863	0.02238	947.7890	46.28	1.18000	0.80000	0.00835	0.01301
867.7110	45.31	1.18000	0.81000	0.00862	0.02101	949.0630	46.26	1.17000	0.81000	0.00832	0.01251
869.0940	45.28	1.18000	0.80000	0.00860	0.02001	950.2110	46.13	1.17000	0.80000	0.00830	0.01290



951.5780	46.30	1.17000	0.80000	0.00837	0.01542	1032.4919	47.23	1.16000	0.81000	0.00812	0.01417
952.7420	46.30	1.17000	0.80000	0.00834	0.01421	1033.8590	47.21	1.16000	0.82000	0.00813	0.01297
953.9380	46.21	1.17000	0.80000	0.00831	0.01394	1035.0699	47.21	1.16000	0.80000	0.00815	0.01341
955.2580	46.32	1.17000	0.80000	0.00831	0.01559	1036.2190	47.25	1.16000	0.81000	0.00815	0.01381
956.4220	46.37	1.17000	0.81000	0.00833	0.01639	1037.4301	47.28	1.16000	0.80000	0.00814	0.01327
957.6170	46.30	1.17000	0.81000	0.00833	0.01438	1038.7500	47.21	1.15000	0.81000	0.00811	0.01305
958.7810	46.35	1.17000	0.80000	0.00832	0.01357	1040.0081	47.25	1.15000	0.79000	0.00818	0.01355
960.1480	46.30	1.17000	0.81000	0.00834	0.01259	1041.1720	47.25	1.15000	0.81000	0.00818	0.01235
961.2970	46.37	1.17000	0.80000	0.00833	0.01265	1042.5389	47.52	1.15000	0.81000	0.00813	0.01312
962.5080	46.32	1.17000	0.79000	0.00834	0.01280	1043.6880	47.34	1.15000	0.80000	0.00812	0.01266
963.8280	46.28	1.17000	0.80000	0.00835	0.01208	1044.8979	47.30	1.15000	0.80000	0.00816	0.01488
965.0390	46.52	1.17000	0.80000	0.00835	0.01337	1046.2190	47.39	1.15000	0.79000	0.00818	0.01459
966.1880	46.37	1.17000	0.81000	0.00832	0.01352	1047.4301	47.45	1.15000	0.80000	0.00815	0.01593
967.5700	46.39	1.17000	0.81000	0.00833	0.01784	1048.5780	47.41	1.15000	0.80000	0.00811	0.01555
968.7730	46.39	1.17000	0.80000	0.00836	0.01793	1049.7340	47.52	1.15000	0.81000	0.00810	0.01728
969.9840	46.48	1.17000	0.79000	0.00832	0.02034	1051.1090	47.54	1.15000	0.79000	0.00811	0.01644
971.1410	46.41	1.17000	0.81000	0.00833	0.01755	1052.2581	47.52	1.15000	0.79000	0.00810	0.01634
972.4530	46.39	1.17000	0.80000	0.00833	0.01692	1053.4690	47.61	1.15000	0.80000	0.00813	0.01584
973.6640	46.48	1.17000	0.79000	0.00832	0.01730	1054.7889	46.95	1.15000	0.81000	0.00815	0.01560
974.8200	46.50	1.17000	0.80000	0.00829	0.01516	1056.0000	47.67	1.15000	0.80000	0.00813	0.01666
976.1880	46.52	1.17000	0.81000	0.00830	0.01606	1057.1479	47.59	1.15000	0.81000	0.00810	0.01493
977.3440	46.55	1.17000	0.81000	0.00828	0.01381	1058.4139	47.59	1.15000	0.80000	0.00811	0.01495
978.5470	46.57	1.17000	0.81000	0.00826	0.01425	1059.6169	47.67	1.15000	0.81000	0.00813	0.01466
979.8670	46.61	1.17000	0.81000	0.00828	0.01266	1060.7729	47.70	1.15000	0.81000	0.00810	0.01337
981.0780	46.55	1.17000	0.80000	0.00831	0.01601	1061.9840	47.74	1.15000	0.81000	0.00811	0.01247
982.2340	46.68	1.17000	0.79000	0.00831	0.01351	1063.2970	47.65	1.15000	0.81000	0.00809	0.01238
983.4380	46.70	1.17000	0.81000	0.00827	0.01378	1064.5081	47.76	1.15000	0.80000	0.00810	0.01317
984.7030	46.66	1.17000	0.81000	0.00825	0.01206	1065.7190	47.74	1.15000	0.81000	0.00814	0.01424
985.9140	46.61	1.17000	0.81000	0.00825	0.01260	1067.0389	47.70	1.15000	0.80000	0.00810	0.01311
987.1170	46.79	1.17000	0.81000	0.00826	0.01158	1068.2419	47.67	1.15000	0.81000	0.00804	0.01427
988.4380	46.77	1.17000	0.81000	0.00830	0.01047	1069.3979	47.74	1.15000	0.81000	0.00805	0.01343
989.6480	46.32	1.17000	0.81000	0.00829	0.01168	1070.5470	47.67	1.15000	0.80000	0.00809	0.01539
990.8520	46.83	1.17000	0.81000	0.00822	0.01061	1071.8669	47.59	1.15000	0.80000	0.00810	0.01567
992.0630	46.83	1.16000	0.80000	0.00822	0.01084	1073.0780	47.70	1.15000	0.81000	0.00813	0.01537
993.3830	46.81	1.16000	0.80000	0.00824	0.01233	1074.2340	47.63	1.15000	0.82000	0.00814	0.01472
994.5940	46.94	1.16000	0.81000	0.00826	0.01465	1075.6021	47.59	1.15000	0.81000	0.00812	0.01506
995.7420	46.88	1.16000	0.80000	0.00824	0.01348	1076.8130	47.67	1.15000	0.80000	0.00810	0.01402
997.0630	47.06	1.16000	0.80000	0.00828	0.01413	1077.9690	47.67	1.15000	0.80000	0.00809	0.01300
998.2110	46.92	1.16000	0.81000	0.00828	0.01368	1079.3440	47.67	1.15000	0.80000	0.00802	0.01122
999.4220	46.92	1.16000	0.81000	0.00824	0.01455	1080.4919	47.81	1.15000	0.79000	0.00803	0.01125
1000.7420	46.86	1.16000	0.79000	0.00826	0.01401	1081.7030	47.81	1.15000	0.80000	0.00804	0.01185
1001.9530	46.94	1.16000	0.79000	0.00830	0.01453	1082.8590	47.76	1.15000	0.81000	0.00804	0.01174
1003.1020	46.97	1.16000	0.81000	0.00826	0.01274	1084.1720	47.85	1.15000	0.81000	0.00802	0.01300
1004.3130	47.14	1.16000	0.81000	0.00822	0.01392	1085.3280	47.83	1.15000	0.82000	0.00801	0.01170
1005.6330	46.92	1.16000	0.80000	0.00829	0.01587	1086.4840	47.81	1.15000	0.79000	0.00806	0.01367
1006.7810	46.94	1.16000	0.81000	0.00831	0.01692	1087.8521	50.27	1.15000	0.80000	0.00812	0.01271
1007.9920	46.94	1.16000	0.81000	0.00835	0.01765	1089.0630	47.94	1.15000	0.80000	0.00808	0.01265
1009.3130	47.08	1.16000	0.81000	0.00830	0.01573	1090.2190	47.94	1.15000	0.82000	0.00804	0.01166
1010.5230	46.99	1.16000	0.81000	0.00832	0.01553	1091.5310	47.81	1.15000	0.81000	0.00801	0.01339
1011.6720	47.12	1.16000	0.79000	0.00829	0.01738	1092.7419	47.79	1.15000	0.82000	0.00809	0.01255
1013.0390	47.14	1.16000	0.79000	0.00832	0.01552	1093.8979	47.81	1.14000	0.80000	0.00809	0.01215
1014.2030	47.01	1.16000	0.81000	0.00827	0.01592	1095.1021	47.85	1.14000	0.81000	0.00806	0.01238
1015.4140	47.14	1.16000	0.80000	0.00824	0.01530	1096.4220	47.92	1.14000	0.80000	0.00806	0.01410
1016.5630	47.03	1.16000	0.80000	0.00827	0.01587	1097.6331	47.85	1.14000	0.80000	0.00808	0.01372
1017.8830	47.10	1.16000	0.81000	0.00828	0.01439	1098.8440	47.90	1.14000	0.80000	0.00807	0.01602
1019.0310	47.12	1.16000	0.81000	0.00831	0.01459	1100.1639	47.83	1.14000	0.81000	0.00804	0.01504
1020.1880	47.06	1.16000	0.81000	0.00830	0.01538	1101.3590	47.92	1.14000	0.82000	0.00802	0.01365
1021.5630	47.12	1.16000	0.80000	0.00829	0.01352	1102.5699	47.94	1.14000	0.80000	0.00803	0.01565
1022.7110	47.14	1.16000	0.80000	0.00830	0.01558	1103.7810	47.96	1.14000	0.80000	0.00805	0.01446
1023.9220	47.14	1.16000	0.81000	0.00822	0.01485	1105.1021	48.25	1.14000	0.81000	0.00807	0.01338
1025.0699	47.19	1.16000	0.80000	0.00820	0.01451	1106.3130	48.03	1.14000	0.80000	0.00803	0.01342
1026.4530	47.70	1.16000	0.80000	0.00820	0.01344	1107.4611	48.05	1.14000	0.80000	0.00803	0.01284
1027.6021	47.19	1.16000	0.81000	0.00818	0.01165	1108.7810	47.50	1.14000	0.80000	0.00800	0.01544
1028.8130	47.19	1.16000	0.80000	0.00821	0.01744	1109.9301	48.16	1.14000	0.80000	0.00798	0.01312
1030.1331	47.19	1.16000	0.80000	0.00816	0.01568	1111.1410	48.25	1.14000	0.80000	0.00800	0.01486
1031.2810	46.88	1.16000	0.80000	0.00813	0.01614	1112.4611	48.25	1.14000	0.80000	0.00801	0.01424

1113.6720	48.21	1.14000	0.79000	0.00798	0.01437	1194.7889	49.24	1.13000	0.79000	0.00801	0.01346
1114.8831	48.27	1.14000	0.79000	0.00797	0.01383	1196.1720	49.29	1.13000	0.79000	0.00802	0.01435
1116.1410	48.21	1.14000	0.82000	0.00799	0.01273	1197.3199	49.15	1.13000	0.79000	0.00805	0.01607
1117.4611	48.49	1.14000	0.80000	0.00795	0.01099	1198.5310	49.27	1.13000	0.82000	0.00804	0.01704
1118.6090	48.47	1.14000	0.79000	0.00794	0.01052	1199.8979	49.35	1.13000	0.78000	0.00802	0.01613
1119.8199	48.32	1.14000	0.81000	0.00795	0.01006	1201.1090	49.36	1.12000	0.81000	0.00807	0.01747
1121.1880	48.36	1.14000	0.79000	0.00795	0.01080	1202.3199	49.35	1.12000	0.78000	0.00803	0.01773
1122.3521	48.49	1.14000	0.80000	0.00796	0.01037	1203.5780	49.24	1.12000	0.79000	0.00802	0.01762
1123.5470	48.32	1.14000	0.81000	0.00799	0.01063	1204.7889	49.33	1.12000	0.80000	0.00796	0.01582
1124.8669	48.38	1.14000	0.82000	0.00800	0.01173	1205.9380	49.49	1.12000	0.80000	0.00794	0.01550
1126.0780	48.58	1.14000	0.80000	0.00804	0.01181	1207.1479	49.33	1.12000	0.82000	0.00790	0.01508
1127.2340	48.38	1.14000	0.80000	0.00803	0.01079	1208.4690	49.53	1.13000	0.79000	0.00790	0.01613
1128.3910	48.43	1.14000	0.80000	0.00801	0.01025	1209.6169	49.47	1.12000	0.79000	0.00788	0.01617
1129.7581	48.45	1.14000	0.80000	0.00809	0.01215	1210.7810	49.38	1.12000	0.80000	0.00788	0.01534
1130.9690	48.40	1.14000	0.79000	0.00808	0.01102	1212.0940	49.78	1.13000	0.79000	0.00790	0.01541
1132.1801	48.51	1.14000	0.82000	0.00804	0.01093	1213.2970	49.49	1.12000	0.80000	0.00785	0.01458
1133.5000	48.51	1.14000	0.79000	0.00799	0.01055	1214.4611	49.47	1.13000	0.80000	0.00780	0.01277
1134.7030	48.49	1.14000	0.80000	0.00796	0.00985	1215.8280	49.60	1.13000	0.79000	0.00782	0.01338
1135.8590	48.43	1.14000	0.80000	0.00798	0.00958	1216.9840	49.58	1.13000	0.80000	0.00779	0.01264
1137.2340	48.47	1.14000	0.80000	0.00800	0.01013	1218.1880	54.84	1.12000	0.81000	0.00782	0.01107
1138.3831	48.43	1.14000	0.80000	0.00794	0.01062	1219.3440	49.44	1.12000	0.80000	0.00783	0.01197
1139.5940	48.63	1.14000	0.79000	0.00793	0.01100	1220.7190	49.51	1.12000	0.82000	0.00783	0.01154
1140.7500	48.45	1.14000	0.80000	0.00791	0.01141	1221.8669	49.51	1.12000	0.80000	0.00781	0.01040
1142.1169	48.58	1.13000	0.78000	0.00791	0.01077	1223.0229	49.51	1.12000	0.80000	0.00787	0.01203
1143.2729	48.38	1.14000	0.79000	0.00790	0.01002	1224.3979	49.51	1.12000	0.80000	0.00787	0.01194
1144.4301	48.51	1.13000	0.79000	0.00792	0.00918	1225.6090	49.55	1.12000	0.79000	0.00782	0.01111
1145.7970	48.56	1.13000	0.79000	0.00793	0.00852	1226.7581	49.47	1.12000	0.79000	0.00781	0.01262
1146.9530	48.58	1.13000	0.81000	0.00794	0.00881	1227.9690	49.58	1.12000	0.80000	0.00782	0.01294
1148.1639	48.60	1.13000	0.81000	0.00789	0.00890	1229.2889	49.49	1.12000	0.81000	0.00787	0.01547
1149.3130	48.56	1.13000	0.80000	0.00791	0.00896	1230.4380	49.47	1.12000	0.79000	0.00784	0.01673
1150.6880	48.60	1.13000	0.79000	0.00795	0.01102	1231.6479	48.78	1.12000	0.80000	0.00787	0.01669
1151.8440	48.56	1.13000	0.79000	0.00801	0.01565	1232.9690	49.53	1.12000	0.79000	0.00793	0.01703
1153.0470	48.60	1.13000	0.79000	0.00801	0.01536	1234.1169	49.53	1.12000	0.79000	0.00793	0.01869
1154.3669	48.58	1.13000	0.80000	0.00797	0.01421	1235.3280	49.51	1.12000	0.80000	0.00791	0.01699
1155.5229	48.56	1.13000	0.80000	0.00796	0.01419	1236.7030	49.60	1.12000	0.80000	0.00785	0.01743
1156.6720	48.60	1.13000	0.79000	0.00798	0.01537	1237.8521	49.67	1.12000	0.81000	0.00790	0.01657
1157.9919	48.65	1.13000	0.80000	0.00795	0.01468	1239.0630	49.67	1.12000	0.79000	0.00798	0.01673
1159.2030	48.51	1.13000	0.80000	0.00796	0.01437	1240.2190	49.60	1.12000	0.79000	0.00805	0.01878
1160.3521	48.74	1.13000	0.79000	0.00804	0.01517	1241.5310	49.64	1.12000	0.80000	0.00801	0.01839
1161.5630	48.62	1.13000	0.79000	0.00807	0.01663	1242.7419	49.82	1.12000	0.79000	0.00799	0.01728
1162.8831	48.47	1.13000	0.81000	0.00804	0.01481	1243.8979	49.82	1.12000	0.80000	0.00800	0.01956
1164.0940	48.71	1.13000	0.81000	0.00810	0.01424	1245.2111	49.73	1.12000	0.80000	0.00802	0.02164
1165.2970	48.62	1.13000	0.79000	0.00811	0.01560	1246.4220	49.73	1.12000	0.80000	0.00804	0.02048
1166.6169	48.74	1.13000	0.80000	0.00804	0.01629	1247.6331	49.69	1.12000	0.81000	0.00807	0.01946
1167.8199	48.87	1.13000	0.81000	0.00799	0.01741	1248.9530	49.80	1.12000	0.80000	0.00813	0.01879
1169.0310	48.89	1.13000	0.79000	0.00796	0.01870	1250.1639	49.78	1.12000	0.79000	0.00813	0.01936
1170.3521	48.82	1.13000	0.79000	0.00790	0.01840	1251.3130	49.84	1.12000	0.79000	0.00806	0.01723
1171.5630	48.89	1.13000	0.79000	0.00792	0.01829	1252.4611	49.89	1.12000	0.80000	0.00808	0.02009
1172.7111	48.94	1.13000	0.80000	0.00793	0.01821	1253.7810	49.93	1.12000	0.79000	0.00803	0.02020
1173.9220	49.07	1.13000	0.81000	0.00793	0.01738	1254.9380	49.95	1.12000	0.80000	0.00804	0.01845
1175.2419	49.02	1.13000	0.79000	0.00793	0.01767	1256.1410	50.00	1.12000	0.80000	0.00807	0.02185
1176.4530	49.09	1.13000	0.80000	0.00794	0.01566	1257.4611	50.00	1.12000	0.80000	0.00810	0.02467
1177.6021	49.27	1.13000	0.80000	0.00800	0.01760	1258.6720	50.04	1.12000	0.79000	0.00814	0.02726
1178.9690	49.24	1.13000	0.79000	0.00800	0.01765	1259.8199	50.09	1.12000	0.80000	0.00816	0.02373
1180.1331	49.18	1.13000	0.80000	0.00800	0.01724	1261.0310	50.11	1.12000	0.80000	0.00817	0.02719
1181.2810	49.25	1.13000	0.80000	0.00797	0.01801	1262.2970	50.24	1.12000	0.79000	0.00812	0.02419
1182.4919	49.22	1.13000	0.81000	0.00796	0.01657	1263.5000	50.17	1.12000	0.81000	0.00809	0.02169
1183.8590	49.13	1.13000	0.79000	0.00791	0.01575	1264.7111	50.31	1.12000	0.82000	0.00807	0.02229
1185.0229	49.27	1.13000	0.80000	0.00794	0.01337	1266.0310	50.33	1.12000	0.80000	0.00802	0.02047
1186.1720	49.33	1.13000	0.79000	0.00794	0.01310	1267.1880	50.31	1.12000	0.81000	0.00802	0.01985
1187.5389	49.27	1.13000	0.80000	0.00793	0.01214	1268.3440	50.40	1.12000	0.79000	0.00805	0.01858
1188.7500	49.18	1.13000	0.79000	0.00791	0.01321	1269.7111	50.37	1.11000	0.79000	0.00803	0.01992
1189.8979	49.24	1.13000	0.81000	0.00798	0.01466	1270.9220	50.59	1.11000	0.81000	0.00804	0.01875
1191.2810	47.26	1.13000	0.79000	0.00797	0.01261	1272.1331	50.66	1.11000	0.79000	0.00800	0.01886
1192.4919	49.24	1.13000	0.80000	0.00802	0.01322	1273.2810	50.77	1.11000	0.79000	0.00799	0.01937
1193.6410	49.13	1.13000	0.80000	0.00805	0.01356	1274.6479	50.79	1.11000	0.79000	0.00795	0.01958

1275.8130	50.93	1.11000	0.78000	0.00797	0.01870	1356.7729	51.90	1.10000	0.80000	0.00803	0.00779
1277.0229	51.02	1.11000	0.79000	0.00797	0.01801	1357.9220	51.86	1.10000	0.79000	0.00804	0.00758
1278.3280	50.97	1.11000	0.79000	0.00801	0.01603	1359.0780	51.79	1.10000	0.79000	0.00801	0.00742
1279.5389	51.10	1.11000	0.80000	0.00799	0.01629	1360.3910	51.66	1.10000	0.79000	0.00802	0.00764
1280.7030	51.17	1.11000	0.79000	0.00802	0.01767	1361.5470	52.41	1.10000	0.79000	0.00800	0.00748
1282.0081	51.26	1.11000	0.82000	0.00799	0.01654	1362.7581	51.64	1.10000	0.80000	0.00800	0.00943
1283.2190	51.21	1.11000	0.79000	0.00800	0.01723	1363.9139	51.55	1.10000	0.80000	0.00797	0.00931
1284.3831	51.21	1.11000	0.80000	0.00798	0.01772	1365.2810	51.66	1.10000	0.81000	0.00797	0.00859
1285.5940	51.24	1.11000	0.81000	0.00801	0.01740	1366.4380	51.48	1.10000	0.81000	0.00797	0.00909
1286.8979	51.32	1.11000	0.79000	0.00802	0.01566	1367.6410	51.48	1.10000	0.79000	0.00797	0.00912
1288.1720	51.26	1.11000	0.81000	0.00804	0.01319	1368.9611	51.64	1.10000	0.81000	0.00792	0.00871
1289.3199	51.41	1.12000	0.80000	0.00808	0.01391	1370.1720	51.61	1.10000	0.80000	0.00790	0.00904
1290.6880	51.41	1.11000	0.80000	0.00806	0.01316	1371.3199	56.57	1.10000	0.80000	0.00790	0.00874
1291.8521	51.50	1.11000	0.80000	0.00808	0.01148	1372.7030	51.61	1.10000	0.79000	0.00794	0.00820
1293.0470	51.55	1.11000	0.79000	0.00810	0.01145	1373.8521	50.91	1.10000	0.81000	0.00794	0.00876
1294.3199	51.68	1.11000	0.80000	0.00808	0.01303	1375.0630	51.84	1.10000	0.81000	0.00793	0.00826
1295.4690	51.59	1.11000	0.79000	0.00804	0.01331	1376.2111	51.70	1.10000	0.80000	0.00794	0.00791
1296.6331	51.46	1.11000	0.78000	0.00801	0.01390	1377.5940	51.79	1.10000	0.80000	0.00796	0.00825
1297.7810	51.61	1.11000	0.80000	0.00803	0.01305	1378.7419	51.88	1.10000	0.81000	0.00795	0.00789
1299.1479	51.66	1.11000	0.79000	0.00809	0.01292	1379.8910	51.79	1.10000	0.80000	0.00796	0.00795
1300.3130	51.41	1.11000	0.79000	0.00810	0.01293	1381.2729	51.75	1.10000	0.80000	0.00797	0.00766
1301.5081	51.66	1.11000	0.80000	0.00808	0.01199	1382.4220	51.86	1.09000	0.80000	0.00795	0.00783
1302.8280	51.66	1.11000	0.82000	0.00805	0.01308	1383.6331	51.66	1.09000	0.80000	0.00793	0.00759
1304.0389	51.61	1.11000	0.80000	0.00804	0.01534	1384.7810	51.70	1.09000	0.80000	0.00790	0.00742
1305.1880	51.68	1.11000	0.80000	0.00806	0.01354	1386.1479	51.68	1.09000	0.81000	0.00788	0.00729
1306.3521	51.66	1.11000	0.79000	0.00806	0.01247	1387.3130	51.68	1.10000	0.79000	0.00789	0.00752
1307.7190	51.66	1.11000	0.80000	0.00805	0.01267	1388.5229	51.97	1.10000	0.81000	0.00791	0.00769
1308.8669	51.66	1.11000	0.80000	0.00802	0.01418	1389.8280	51.57	1.10000	0.81000	0.00790	0.00747
1310.0780	51.63	1.11000	0.78000	0.00801	0.01397	1391.0389	51.70	1.10000	0.80000	0.00790	0.00734
1311.3979	51.70	1.11000	0.79000	0.00804	0.01248	1392.2030	51.75	1.09000	0.80000	0.00791	0.00724
1312.6639	51.75	1.11000	0.79000	0.00804	0.01238	1393.5699	51.75	1.10000	0.81000	0.00790	0.00716
1313.8199	51.70	1.11000	0.78000	0.00800	0.01240	1394.7190	51.73	1.09000	0.79000	0.00791	0.00711
1315.1880	51.70	1.11000	0.79000	0.00801	0.01186	1395.8831	51.77	1.09000	0.79000	0.00790	0.00708
1316.3440	51.70	1.11000	0.80000	0.00803	0.01246	1397.1410	51.73	1.09000	0.80000	0.00788	0.00705
1317.5000	51.88	1.11000	0.81000	0.00803	0.01181	1398.4611	51.82	1.09000	0.81000	0.00787	0.00703
1318.7111	51.61	1.10000	0.81000	0.00803	0.01174	1399.6720	51.73	1.09000	0.79000	0.00786	0.00701
1319.9690	51.57	1.10000	0.80000	0.00800	0.01061	1400.8199	51.86	1.09000	0.80000	0.00786	0.00700
1321.1801	51.72	1.10000	0.81000	0.00800	0.00964	1402.1880	51.93	1.09000	0.79000	0.00787	0.00699
1322.3280	51.64	1.10000	0.82000	0.00800	0.01122	1403.3521	51.84	1.09000	0.81000	0.00785	0.00698
1323.7030	51.66	1.10000	0.80000	0.00799	0.01074	1404.5000	51.88	1.09000	0.81000	0.00784	0.00724
1324.8590	51.72	1.10000	0.80000	0.00800	0.00972	1405.8669	51.93	1.09000	0.81000	0.00786	0.00716
1326.0699	51.79	1.11000	0.79000	0.00803	0.01039	1407.0310	51.97	1.09000	0.80000	0.00785	0.00711
1327.3831	51.75	1.10000	0.79000	0.00802	0.01077	1408.2340	51.97	1.09000	0.80000	0.00785	0.00708
1328.5389	51.79	1.10000	0.80000	0.00799	0.01026	1409.3910	51.97	1.09000	0.81000	0.00785	0.00705
1329.7500	51.79	1.10000	0.80000	0.00800	0.01024	1410.7111	51.97	1.09000	0.80000	0.00786	0.00703
1330.8979	51.79	1.10000	0.80000	0.00801	0.00967	1411.8590	52.02	1.09000	0.81000	0.00787	0.00702
1332.2729	51.70	1.10000	0.80000	0.00801	0.00886	1413.0699	52.24	1.09000	0.80000	0.00787	0.00701
1333.4840	51.70	1.10000	0.80000	0.00802	0.00835	1414.3910	52.08	1.09000	0.80000	0.00788	0.00700
1334.6331	51.68	1.10000	0.80000	0.00802	0.00798	1415.5389	52.13	1.09000	0.81000	0.00788	0.00700
1335.9530	51.66	1.10000	0.79000	0.00802	0.00796	1416.7970	52.15	1.09000	0.80000	0.00787	0.00699
1337.1639	51.59	1.10000	0.79000	0.00799	0.00770	1417.9611	52.17	1.09000	0.80000	0.00786	0.00699
1338.3130	51.59	1.10000	0.81000	0.00797	0.00882	1419.3280	52.15	1.09000	0.79000	0.00785	0.00700
1339.5229	51.52	1.10000	0.80000	0.00798	0.00899	1420.4840	51.73	1.09000	0.81000	0.00782	0.00700
1340.8440	51.55	1.10000	0.80000	0.00797	0.00837	1421.6880	52.24	1.09000	0.81000	0.00781	0.00699
1341.9919	51.59	1.10000	0.80000	0.00796	0.00799	1423.0081	52.32	1.09000	0.80000	0.00780	0.00699
1343.2030	51.59	1.10000	0.80000	0.00798	0.00773	1424.2190	47.66	1.09000	0.80000	0.00780	0.00698
1344.5229	51.63	1.10000	0.80000	0.00798	0.00972	1425.4301	52.35	1.09000	0.80000	0.00780	0.00698
1345.7340	51.66	1.10000	0.80000	0.00799	0.00894	1426.7419	52.39	1.09000	0.79000	0.00780	0.00698
1346.8831	51.86	1.10000	0.79000	0.00802	0.00903	1427.9530	52.39	1.09000	0.80000	0.00779	0.00698
1348.2030	51.77	1.10000	0.80000	0.00797	0.00841	1429.1090	52.46	1.09000	0.80000	0.00778	0.00698
1349.4139	51.68	1.10000	0.80000	0.00794	0.00802	1430.3669	52.44	1.09000	0.80000	0.00779	0.00729
1350.5630	51.83	1.10000	0.80000	0.00796	0.00834	1431.6880	52.50	1.09000	0.81000	0.00781	0.00718
1351.7729	51.83	1.10000	0.80000	0.00800	0.00797	1432.8979	52.39	1.09000	0.79000	0.00780	0.00713
1353.0940	51.90	1.11000	0.81000	0.00804	0.00920	1434.0470	52.48	1.09000	0.81000	0.00778	0.00708
1354.2970	51.90	1.10000	0.80000	0.00802	0.00858	1435.4220	52.44	1.09000	0.81000	0.00778	0.00705
1355.4530	51.99	1.10000	0.81000	0.00802	0.00814	1436.5780	52.44	1.09000	0.81000	0.00777	0.00703

1437.7810	52.50	1.09000	0.80000	0.00777	0.00701	1518.7970	54.06	1.07000	0.80000	0.00755	0.00696
1439.1021	52.37	1.09000	0.80000	0.00778	0.00700	1520.0081	53.97	1.07000	0.81000	0.00754	0.00696
1440.3130	52.46	1.09000	0.80000	0.00778	0.00699	1521.1639	54.13	1.07000	0.80000	0.00755	0.00696
1441.4611	52.55	1.09000	0.80000	0.00777	0.00698	1522.5310	54.13	1.07000	0.80000	0.00753	0.00696
1442.6720	52.48	1.08000	0.79000	0.00776	0.00698	1523.6880	54.17	1.07000	0.79000	0.00752	0.00696
1443.9919	52.51	1.09000	0.79000	0.00776	0.00698	1524.8979	54.15	1.07000	0.79000	0.00751	0.00696
1445.2030	52.53	1.09000	0.80000	0.00776	0.00697	1526.1639	54.18	1.07000	0.81000	0.00752	0.00696
1446.3521	52.53	1.08000	0.81000	0.00775	0.00697	1527.3669	54.37	1.07000	0.80000	0.00752	0.00696
1447.7340	52.57	1.09000	0.80000	0.00775	0.00697	1528.5229	54.17	1.07000	0.80000	0.00748	0.00696
1448.8831	52.62	1.09000	0.80000	0.00774	0.00697	1529.8910	54.09	1.07000	0.79000	0.00747	0.00696
1450.0940	52.55	1.09000	0.79000	0.00773	0.00696	1531.0470	54.42	1.07000	0.80000	0.00749	0.00696
1451.4139	52.59	1.09000	0.81000	0.00772	0.00696	1532.2581	54.35	1.07000	0.81000	0.00748	0.00696
1452.6090	52.66	1.08000	0.80000	0.00771	0.00697	1533.4139	54.44	1.07000	0.80000	0.00749	0.00696
1453.8199	52.73	1.09000	0.80000	0.00772	0.00696	1534.7340	54.42	1.07000	0.80000	0.00747	0.00696
1454.9840	52.66	1.08000	0.80000	0.00772	0.00696	1535.9919	54.44	1.07000	0.81000	0.00746	0.00697
1456.3521	52.79	1.08000	0.80000	0.00768	0.00696	1537.1410	54.40	1.07000	0.80000	0.00747	0.00697
1457.5000	52.82	1.08000	0.80000	0.00768	0.00696	1538.5229	54.33	1.07000	0.80000	0.00747	0.00697
1458.7111	52.75	1.08000	0.80000	0.00768	0.00696	1539.6720	54.53	1.07000	0.79000	0.00746	0.00697
1460.0310	52.88	1.08000	0.79000	0.00769	0.00696	1540.9301	54.53	1.07000	0.81000	0.00745	0.00697
1461.2419	52.80	1.08000	0.80000	0.00766	0.00697	1542.1410	54.60	1.07000	0.81000	0.00746	0.00697
1462.3910	52.93	1.08000	0.80000	0.00766	0.00697	1543.5229	54.55	1.07000	0.80000	0.00744	0.00697
1463.6021	52.99	1.08000	0.79000	0.00767	0.00697	1544.6720	54.62	1.07000	0.79000	0.00748	0.00697
1464.9220	53.02	1.08000	0.81000	0.00767	0.00697	1545.8831	54.71	1.07000	0.80000	0.00749	0.00697
1466.0699	53.06	1.08000	0.80000	0.00766	0.00696	1547.2030	54.64	1.07000	0.80000	0.00748	0.00696
1467.2810	53.11	1.08000	0.81000	0.00768	0.00697	1548.3979	54.60	1.07000	0.81000	0.00745	0.00697
1468.6021	53.13	1.08000	0.80000	0.00769	0.00697	1549.5630	54.82	1.07000	0.79000	0.00747	0.00697
1469.8590	53.22	1.09000	0.80000	0.00771	0.00697	1550.9301	54.75	1.07000	0.80000	0.00747	0.00697
1470.9611	53.26	1.09000	0.80000	0.00772	0.00697	1552.1410	56.15	1.07000	0.79000	0.00747	0.00697
1472.3280	53.17	1.09000	0.80000	0.00773	0.00696	1553.2889	54.89	1.07000	0.79000	0.00746	0.00696
1473.4919	53.24	1.09000	0.80000	0.00773	0.00697	1554.4530	54.77	1.07000	0.81000	0.00744	0.00696
1474.6880	53.19	1.09000	0.79000	0.00774	0.00696	1555.8199	54.80	1.07000	0.81000	0.00744	0.00696
1475.8521	53.24	1.08000	0.81000	0.00773	0.00696	1557.0310	54.91	1.07000	0.79000	0.00743	0.00696
1477.1720	53.30	1.08000	0.80000	0.00769	0.00696	1558.2419	54.80	1.07000	0.80000	0.00742	0.00696
1478.3669	53.30	1.08000	0.80000	0.00769	0.00696	1559.5470	54.98	1.07000	0.78000	0.00744	0.00696
1479.5780	53.28	1.08000	0.79000	0.00769	0.00696	1560.7581	54.95	1.07000	0.80000	0.00746	0.00696
1480.8521	53.39	1.08000	0.81000	0.00766	0.00696	1561.9690	54.93	1.07000	0.81000	0.00743	0.00696
1482.0470	53.42	1.08000	0.80000	0.00763	0.00696	1563.2340	55.04	1.07000	0.81000	0.00742	0.00696
1483.2111	53.44	1.08000	0.81000	0.00763	0.00696	1564.4380	55.02	1.07000	0.80000	0.00741	0.00696
1484.5310	53.15	1.08000	0.80000	0.00764	0.00696	1565.6021	55.11	1.07000	0.80000	0.00743	0.00697
1485.7340	53.46	1.08000	0.80000	0.00765	0.00696	1566.7500	55.06	1.07000	0.79000	0.00745	0.00696
1486.8910	53.35	1.08000	0.79000	0.00766	0.00696	1568.1169	55.04	1.07000	0.80000	0.00744	0.00696
1488.1021	53.37	1.08000	0.80000	0.00766	0.00696	1569.2810	55.18	1.07000	0.81000	0.00743	0.00696
1489.4139	53.28	1.08000	0.81000	0.00765	0.00696	1570.4840	55.18	1.07000	0.79000	0.00742	0.00696
1490.6169	53.46	1.08000	0.79000	0.00766	0.00696	1571.7970	55.31	1.07000	0.79000	0.00742	0.00696
1491.7810	53.57	1.08000	0.80000	0.00768	0.00696	1572.9611	55.18	1.07000	0.80000	0.00743	0.00696
1493.0940	53.53	1.08000	0.81000	0.00764	0.00697	1574.1639	55.33	1.07000	0.80000	0.00743	0.00696
1494.2500	53.48	1.08000	0.81000	0.00760	0.00697	1575.3199	55.33	1.07000	0.81000	0.00741	0.00696
1495.4611	53.95	1.08000	0.79000	0.00760	0.00697	1576.6410	55.29	1.07000	0.81000	0.00737	0.00696
1496.6090	53.55	1.08000	0.80000	0.00762	0.00697	1577.7889	55.35	1.07000	0.81000	0.00738	0.00696
1497.9840	53.55	1.08000	0.81000	0.00760	0.00696	1579.0000	55.33	1.06000	0.81000	0.00737	0.00696
1499.1880	53.68	1.08000	0.80000	0.00759	0.00696	1580.3199	55.42	1.06000	0.80000	0.00732	0.00696
1500.3440	53.62	1.08000	0.79000	0.00756	0.00696	1581.5229	55.49	1.07000	0.78000	0.00738	0.00696
1501.6639	53.66	1.08000	0.80000	0.00756	0.00696	1582.6801	55.40	1.07000	0.79000	0.00739	0.00780
1502.8669	53.66	1.08000	0.79000	0.00756	0.00696	1584.0000	55.55	1.06000	0.80000	0.00741	0.00754
1504.0780	53.71	1.08000	0.81000	0.00756	0.00696	1585.2030	55.55	1.07000	0.82000	0.00738	0.00739
1505.3979	53.75	1.08000	0.81000	0.00755	0.00696	1586.3590	55.49	1.07000	0.79000	0.00735	0.00728
1506.6090	53.71	1.08000	0.80000	0.00755	0.00696	1587.5699	55.62	1.07000	0.80000	0.00735	0.00720
1507.7581	53.71	1.08000	0.80000	0.00756	0.00696	1588.8831	55.73	1.06000	0.80000	0.00736	0.00713
1508.9690	53.77	1.08000	0.80000	0.00757	0.00697	1590.0389	55.60	1.07000	0.80000	0.00736	0.00709
1510.2889	53.53	1.08000	0.80000	0.00756	0.00697	1591.2500	55.67	1.07000	0.81000	0.00737	0.00706
1511.4919	53.84	1.08000	0.80000	0.00757	0.00697	1592.6169	55.75	1.07000	0.80000	0.00736	0.00704
1512.6479	53.84	1.08000	0.81000	0.00757	0.00697	1593.7729	55.64	1.06000	0.82000	0.00732	0.00702
1513.9690	53.73	1.08000	0.81000	0.00757	0.00697	1594.9301	55.87	1.06000	0.82000	0.00729	0.00701
1515.1720	53.91	1.08000	0.80000	0.00757	0.00697	1596.2419	55.75	1.06000	0.79000	0.00734	0.00700
1516.3280	53.91	1.08000	0.80000	0.00757	0.00697	1597.3979	55.78	1.06000	0.79000	0.00734	0.00699
1517.6479	54.04	1.08000	0.79000	0.00757	0.00696	1598.6090	55.84	1.06000	0.81000	0.00731	0.00699



1599.7581	55.84	1.06000	0.81000	0.00730	0.00699	1681.1639	57.31	1.05000	0.81000	0.00711	0.00782
1601.1331	55.95	1.06000	0.79000	0.00732	0.00699	1682.3130	56.47	1.05000	0.81000	0.00707	0.00758
1602.2889	55.89	1.07000	0.81000	0.00734	0.00699	1683.6331	57.31	1.05000	0.79000	0.00708	0.00740
1603.4380	55.93	1.07000	0.79000	0.00732	0.00699	1684.8440	57.33	1.05000	0.79000	0.00709	0.00728
1604.8130	56.04	1.07000	0.80000	0.00734	0.00698	1685.9919	57.33	1.05000	0.80000	0.00710	0.00720
1605.9690	56.02	1.07000	0.80000	0.00734	0.00698	1687.3669	57.40	1.05000	0.82000	0.00709	0.00713
1607.1720	56.04	1.06000	0.79000	0.00733	0.00698	1688.5229	57.31	1.06000	0.80000	0.00707	0.00709
1608.4919	56.00	1.07000	0.79000	0.00734	0.00698	1689.7340	57.47	1.05000	0.81000	0.00711	0.00706
1609.7030	55.91	1.07000	0.81000	0.00735	0.00698	1690.8831	57.54	1.05000	0.81000	0.00710	0.00704
1610.8521	56.18	1.07000	0.79000	0.00734	0.00698	1692.2500	57.47	1.05000	0.79000	0.00709	0.00703
1612.0630	56.13	1.07000	0.80000	0.00734	0.00698	1693.4139	57.47	1.05000	0.78000	0.00708	0.00701
1613.3831	56.15	1.06000	0.80000	0.00733	0.00698	1694.5630	57.47	1.05000	0.78000	0.00710	0.00700
1614.5940	59.81	1.06000	0.79000	0.00733	0.00698	1695.9301	57.45	1.05000	0.80000	0.00710	0.00699
1615.7419	56.31	1.06000	0.82000	0.00732	0.00698	1697.1410	57.51	1.05000	0.82000	0.00707	0.00699
1617.0630	56.27	1.06000	0.80000	0.00730	0.00698	1698.2419	57.54	1.05000	0.81000	0.00706	0.00698
1618.3199	56.22	1.06000	0.79000	0.00727	0.00698	1699.4530	57.49	1.05000	0.82000	0.00705	0.00698
1619.4840	56.29	1.06000	0.81000	0.00727	0.00698	1700.7729	57.56	1.05000	0.81000	0.00705	0.00698
1620.6880	56.31	1.06000	0.80000	0.00728	0.00698	1701.9220	57.58	1.05000	0.80000	0.00705	0.00699
1622.0000	56.47	1.06000	0.80000	0.00728	0.00698	1703.1331	57.58	1.05000	0.78000	0.00708	0.00698
1623.2111	56.42	1.06000	0.81000	0.00728	0.00697	1704.4530	57.71	1.05000	0.79000	0.00704	0.00698
1624.3669	56.44	1.06000	0.81000	0.00727	0.00698	1705.6639	57.67	1.05000	0.80000	0.00707	0.00698
1625.6801	56.36	1.06000	0.82000	0.00722	0.00698	1706.8130	57.63	1.05000	0.82000	0.00708	0.00698
1626.8440	56.38	1.06000	0.79000	0.00724	0.00698	1708.1801	57.56	1.05000	0.80000	0.00705	0.00698
1627.9919	56.44	1.06000	0.81000	0.00723	0.00698	1709.3910	57.65	1.05000	0.81000	0.00701	0.00698
1629.3590	56.33	1.06000	0.79000	0.00719	0.00699	1710.5389	57.58	1.05000	0.81000	0.00698	0.00698
1630.5229	56.56	1.06000	0.78000	0.00719	0.00699	1711.7030	57.43	1.05000	0.80000	0.00700	0.00698
1631.7340	56.44	1.06000	0.80000	0.00719	0.00699	1713.0699	57.67	1.05000	0.78000	0.00702	0.00697
1632.8831	56.60	1.06000	0.81000	0.00719	0.00699	1714.2190	57.71	1.05000	0.78000	0.00703	0.00697
1634.2500	56.64	1.06000	0.82000	0.00715	0.00700	1715.4301	57.71	1.05000	0.79000	0.00702	0.00803
1635.4139	56.62	1.06000	0.79000	0.00713	0.00699	1716.7500	57.74	1.05000	0.81000	0.00699	0.00750
1636.6090	56.89	1.06000	0.80000	0.00719	0.00699	1717.9611	57.63	1.05000	0.81000	0.00700	0.00750
1637.9301	56.76	1.06000	0.78000	0.00721	0.00803	1719.1090	57.71	1.05000	0.81000	0.00699	0.00735
1639.1410	57.87	1.06000	0.80000	0.00722	0.00831	1720.4301	57.67	1.05000	0.81000	0.00697	0.00724
1640.3521	56.71	1.05000	0.79000	0.00719	0.00793	1721.6410	57.74	1.05000	0.81000	0.00697	0.00717
1641.6720	56.65	1.05000	0.80000	0.00716	0.00764	1722.7889	57.78	1.05000	0.81000	0.00698	0.00712
1642.8199	57.61	1.06000	0.81000	0.00716	0.00746	1724.0000	57.80	1.05000	0.79000	0.00699	0.00708
1643.9690	56.80	1.06000	0.79000	0.00716	0.00734	1725.3199	57.85	1.05000	0.80000	0.00696	0.00705
1645.1801	56.71	1.05000	0.81000	0.00716	0.00725	1726.4690	57.74	1.05000	0.80000	0.00696	0.00704
1646.5000	56.76	1.05000	0.79000	0.00715	0.00717	1727.6801	57.74	1.05000	0.78000	0.00700	0.00702
1647.7581	56.87	1.05000	0.81000	0.00714	0.00712	1729.0000	57.87	1.05000	0.78000	0.00701	0.00756
1648.9220	56.82	1.05000	0.81000	0.00714	0.00708	1730.2111	57.74	1.05000	0.78000	0.00702	0.00739
1650.2889	56.85	1.05000	0.79000	0.00716	0.00706	1731.3590	57.85	1.05000	0.80000	0.00699	0.00728
1651.4380	56.89	1.05000	0.81000	0.00715	0.00704	1732.5699	57.85	1.05000	0.79000	0.00699	0.00719
1652.6479	56.96	1.05000	0.79000	0.00713	0.00703	1733.8910	57.76	1.05000	0.81000	0.00698	0.00713
1653.8130	56.98	1.06000	0.80000	0.00713	0.00702	1735.1021	57.74	1.05000	0.80000	0.00698	0.00709
1655.1801	56.85	1.05000	0.80000	0.00713	0.00701	1736.2500	57.83	1.05000	0.78000	0.00698	0.00706
1656.3910	56.94	1.05000	0.79000	0.00708	0.00701	1737.5699	57.78	1.05000	0.79000	0.00693	0.00703
1657.5389	57.00	1.05000	0.81000	0.00705	0.00700	1738.7190	57.80	1.05000	0.80000	0.00693	0.00702
1658.9139	56.85	1.05000	0.79000	0.00708	0.00700	1739.9840	57.89	1.05000	0.80000	0.00695	0.00701
1660.1169	57.07	1.05000	0.78000	0.00717	0.01003	1741.2970	57.47	1.05000	0.81000	0.00697	0.00700
1661.2810	57.02	1.05000	0.79000	0.00718	0.01013	1742.5081	58.00	1.05000	0.78000	0.00699	0.00699
1662.5940	57.02	1.06000	0.79000	0.00718	0.00915	1743.6639	57.91	1.05000	0.79000	0.00703	0.00766
1663.7970	56.98	1.05000	0.81000	0.00716	0.00921	1744.8199	58.20	1.04000	0.82000	0.00701	0.00746
1664.9611	57.16	1.05000	0.81000	0.00714	0.00858	1746.1880	57.83	1.04000	0.80000	0.00697	0.00731
1666.1639	57.11	1.05000	0.79000	0.00712	0.00815	1747.3440	53.03	1.04000	0.78000	0.00691	0.00722
1667.4840	57.09	1.05000	0.80000	0.00711	0.00779	1748.6090	58.02	1.05000	0.79000	0.00688	0.00715
1668.7500	57.11	1.05000	0.80000	0.00710	0.00757	1749.9301	57.91	1.05000	0.80000	0.00690	0.00710
1669.9530	57.16	1.05000	0.81000	0.00711	0.00741	1751.1331	58.14	1.04000	0.80000	0.00693	0.00707
1671.3280	57.13	1.05000	0.80000	0.00711	0.00728	1752.2889	58.03	1.04000	0.80000	0.00697	0.00844
1672.4840	57.16	1.05000	0.79000	0.00710	0.00720	1753.6090	57.98	1.04000	0.79000	0.00697	0.00893
1673.6880	57.13	1.05000	0.81000	0.00708	0.00714	1754.8130	58.05	1.05000	0.81000	0.00695	0.00837
1675.0081	57.22	1.05000	0.80000	0.00703	0.00709	1756.0229	58.09	1.04000	0.81000	0.00694	0.00798
1676.2190	56.73	1.05000	0.81000	0.00711	0.00877	1757.1801	57.96	1.04000	0.80000	0.00692	0.00771
1677.3669	57.27	1.05000	0.80000	0.00714	0.00824	1758.5470	58.12	1.04000	0.81000	0.00691	0.00749
1678.6331	57.27	1.05000	0.80000	0.00714	0.00865	1759.7030	58.14	1.04000	0.82000	0.00688	0.00735
1679.9530	57.33	1.05000	0.80000	0.00711	0.00812	1760.9139	58.05	1.04000	0.81000	0.00688	0.00725

1762.2340	58.18	1.04000	0.81000	0.00682	0.00717	1843.0780	59.79	1.03000	0.80000	0.00661	0.00724
1763.4380	58.16	1.04000	0.78000	0.00684	0.00711	1844.3979	59.88	1.03000	0.82000	0.00660	0.00717
1764.5940	58.14	1.04000	0.78000	0.00687	0.00708	1845.5470	59.72	1.03000	0.79000	0.00666	0.00812
1765.9139	58.18	1.04000	0.81000	0.00686	0.00705	1846.7030	59.99	1.03000	0.78000	0.00667	0.00950
1767.1169	58.12	1.04000	0.81000	0.00685	0.00703	1847.9139	60.05	1.03000	0.81000	0.00667	0.00879
1768.2729	57.56	1.04000	0.80000	0.00686	0.00702	1849.2340	60.08	1.03000	0.81000	0.00666	0.00823
1769.4840	58.18	1.04000	0.80000	0.00685	0.00701	1850.4380	60.12	1.03000	0.80000	0.00660	0.00788
1770.7970	58.18	1.04000	0.81000	0.00685	0.00700	1851.5940	60.30	1.03000	0.78000	0.00666	0.00763
1771.9530	58.25	1.04000	0.79000	0.00684	0.00699	1852.9690	60.28	1.03000	0.80000	0.00664	0.00743
1773.1639	58.34	1.04000	0.81000	0.00682	0.00699	1854.1169	60.39	1.03000	0.82000	0.00658	0.00730
1774.4840	58.27	1.04000	0.82000	0.00678	0.00698	1855.2729	59.81	1.03000	0.80000	0.00663	0.00721
1775.6880	58.14	1.04000	0.79000	0.00674	0.00698	1856.4840	60.39	1.03000	0.78000	0.00662	0.00715
1776.8440	58.36	1.04000	0.81000	0.00678	0.00698	1857.7970	60.46	1.03000	0.82000	0.00657	0.00709
1778.0470	58.23	1.04000	0.81000	0.00680	0.00698	1858.9530	60.50	1.03000	0.78000	0.00652	0.00706
1779.3669	58.38	1.04000	0.81000	0.00680	0.00698	1860.1090	60.48	1.03000	0.81000	0.00651	0.00704
1780.5699	58.40	1.04000	0.82000	0.00680	0.00698	1861.4840	60.52	1.03000	0.81000	0.00657	0.00701
1781.7340	58.34	1.04000	0.81000	0.00680	0.00698	1862.6331	60.59	1.03000	0.83000	0.00659	0.00864
1783.0470	58.40	1.04000	0.80000	0.00681	0.00698	1863.8440	60.70	1.03000	0.80000	0.00656	0.00816
1784.2500	58.38	1.04000	0.79000	0.00681	0.00698	1865.1021	60.66	1.03000	0.81000	0.00649	0.00780
1785.4611	58.36	1.04000	0.79000	0.00677	0.00698	1866.3669	60.77	1.03000	0.80000	0.00651	0.00756
1786.7810	58.40	1.04000	0.80000	0.00679	0.00698	1867.5229	60.57	1.03000	0.78000	0.00650	0.00740
1787.9919	57.99	1.04000	0.83000	0.00674	0.00698	1868.7340	60.63	1.02000	0.78000	0.00655	0.00916
1789.1410	58.52	1.04000	0.79000	0.00671	0.00697	1870.0470	60.79	1.03000	0.81000	0.00655	0.00846
1790.3521	58.56	1.04000	0.79000	0.00673	0.00698	1871.2581	60.63	1.03000	0.79000	0.00647	0.00805
1791.6720	58.58	1.04000	0.79000	0.00678	0.00698	1872.4139	60.72	1.02000	0.79000	0.00648	0.00775
1792.8199	58.50	1.04000	0.79000	0.00680	0.00753	1873.7340	60.77	1.02000	0.79000	0.00656	0.00972
1794.0310	58.58	1.04000	0.80000	0.00679	0.00737	1874.9919	60.83	1.02000	0.80000	0.00657	0.00891
1795.3521	58.50	1.04000	0.79000	0.00678	0.00725	1876.1410	60.81	1.02000	0.82000	0.00653	0.00837
1796.5630	58.58	1.04000	0.79000	0.00677	0.00718	1877.5229	60.81	1.03000	0.81000	0.00648	0.00795
1797.7111	58.63	1.04000	0.80000	0.00674	0.00712	1878.6720	60.79	1.02000	0.80000	0.00651	0.00768
1799.0780	58.67	1.04000	0.79000	0.00679	0.00708	1879.8831	60.88	1.02000	0.78000	0.00653	0.00843
1800.2419	58.67	1.04000	0.80000	0.00681	0.00705	1881.0310	60.88	1.02000	0.82000	0.00653	0.00802
1801.4530	58.76	1.04000	0.81000	0.00681	0.00703	1882.3521	60.61	1.03000	0.79000	0.00648	0.00770
1802.6021	58.81	1.04000	0.81000	0.00679	0.00702	1883.6090	60.74	1.03000	0.80000	0.00646	0.00749
1803.9690	58.83	1.04000	0.82000	0.00676	0.00701	1884.7729	60.97	1.03000	0.79000	0.00653	0.00734
1805.1331	58.94	1.04000	0.83000	0.00673	0.00700	1886.1410	60.97	1.03000	0.80000	0.00655	0.00822
1806.2810	59.03	1.04000	0.81000	0.00671	0.00700	1887.2889	60.97	1.03000	0.80000	0.00653	0.00786
1807.6479	58.98	1.04000	0.81000	0.00677	0.00699	1888.5000	61.08	1.03000	0.82000	0.00648	0.00761
1808.8130	58.98	1.04000	0.80000	0.00680	0.00699	1889.6639	60.97	1.03000	0.80000	0.00650	0.00744
1810.0081	59.01	1.04000	0.81000	0.00678	0.00698	1890.9690	61.03	1.02000	0.80000	0.00656	0.00851
1811.1720	59.10	1.04000	0.80000	0.00673	0.00698	1892.2419	61.12	1.02000	0.82000	0.00655	0.00806
1812.4919	58.30	1.04000	0.79000	0.00675	0.00698	1893.3910	61.03	1.02000	0.81000	0.00652	0.00775
1813.6410	59.19	1.04000	0.80000	0.00677	0.00698	1894.7581	61.17	1.02000	0.80000	0.00649	0.00751
1814.7889	59.23	1.04000	0.79000	0.00676	0.00698	1895.9220	61.17	1.02000	0.81000	0.00644	0.00736
1816.1720	59.39	1.04000	0.80000	0.00671	0.00697	1897.0699	61.12	1.02000	0.78000	0.00649	0.00726
1817.3199	59.16	1.04000	0.81000	0.00670	0.00697	1898.4380	61.12	1.02000	0.81000	0.00648	0.00718
1818.5310	59.27	1.04000	0.82000	0.00668	0.00697	1899.6479	61.17	1.02000	0.81000	0.00640	0.00712
1819.8521	59.34	1.04000	0.78000	0.00671	0.00697	1900.8590	61.10	1.02000	0.82000	0.00637	0.00708
1821.0470	59.41	1.04000	0.80000	0.00677	0.00849	1902.0081	61.10	1.02000	0.80000	0.00642	0.00705
1822.2111	59.52	1.04000	0.81000	0.00677	0.00805	1903.3910	61.23	1.02000	0.78000	0.00646	0.00785
1823.3590	59.45	1.04000	0.79000	0.00677	0.00774	1904.5389	61.28	1.02000	0.81000	0.00646	0.00760
1824.6801	59.32	1.04000	0.80000	0.00676	0.00751	1905.6880	61.21	1.02000	0.81000	0.00643	0.00743
1825.8280	59.45	1.04000	0.79000	0.00673	0.00736	1907.0699	61.15	1.02000	0.81000	0.00646	0.00729
1827.0389	59.54	1.04000	0.81000	0.00669	0.00726	1908.2810	61.26	1.02000	0.79000	0.00646	0.00721
1828.3590	59.56	1.04000	0.81000	0.00671	0.00716	1909.4301	61.19	1.02000	0.80000	0.00645	0.00714
1829.5699	59.59	1.04000	0.80000	0.00674	0.00710	1910.7500	61.21	1.02000	0.82000	0.00644	0.00709
1830.7190	59.68	1.04000	0.81000	0.00675	0.00706	1911.9611	61.26	1.02000	0.81000	0.00643	0.00706
1832.0389	59.63	1.04000	0.79000	0.00674	0.00703	1913.1090	61.28	1.02000	0.80000	0.00642	0.00704
1833.1880	59.65	1.04000	0.82000	0.00670	0.00701	1914.3199	61.86	1.02000	0.82000	0.00634	0.00704
1834.3979	59.65	1.04000	0.81000	0.00670	0.00700	1915.6410	61.37	1.02000	0.80000	0.00634	0.00701
1835.5470	59.56	1.04000	0.79000	0.00667	0.00698	1916.8440	61.32	1.02000	0.80000	0.00636	0.00700
1836.9301	59.76	1.03000	0.82000	0.00665	0.00699	1918.0000	61.26	1.02000	0.81000	0.00641	0.00842
1838.1410	59.85	1.03000	0.79000	0.00671	0.00804	1919.3669	61.41	1.02000	0.81000	0.00641	0.00794
1839.2889	59.74	1.03000	0.80000	0.00673	0.00772	1920.5229	61.30	1.02000	0.80000	0.00637	0.00766
1840.6639	59.79	1.03000	0.82000	0.00671	0.00749	1921.7340	61.33	1.02000	0.81000	0.00636	0.00748
1841.8669	59.88	1.03000	0.80000	0.00665	0.00735	1923.0470	61.44	1.02000	0.80000	0.00642	0.00733

1924.2581	61.35	1.02000	0.81000	0.00647	0.00852	2005.4380	62.09	1.01000	0.79000	0.00630	0.00706
1925.4139	61.41	1.02000	0.81000	0.00644	0.00809	2006.8130	62.15	1.01000	0.80000	0.00629	0.00703
1926.5699	61.48	1.02000	0.79000	0.00638	0.00777	2007.9690	62.62	1.02000	0.80000	0.00628	0.00701
1927.8831	61.59	1.02000	0.79000	0.00641	0.00753	2009.1169	62.15	1.01000	0.80000	0.00629	0.00700
1929.0389	61.53	1.02000	0.81000	0.00646	0.00927	2010.4380	62.13	1.01000	0.81000	0.00628	0.00699
1930.2500	61.57	1.02000	0.79000	0.00644	0.00861	2011.6479	62.13	1.01000	0.81000	0.00624	0.00698
1931.5630	61.50	1.02000	0.82000	0.00637	0.00810	2012.7970	62.15	1.01000	0.80000	0.00620	0.00698
1932.7729	61.46	1.02000	0.79000	0.00637	0.00778	2014.0081	62.15	1.01000	0.80000	0.00625	0.00697
1933.9840	61.35	1.02000	0.78000	0.00643	0.00952	2015.3280	62.15	1.01000	0.80000	0.00624	0.00697
1935.1880	61.55	1.02000	0.82000	0.00642	0.00877	2016.5310	62.11	1.01000	0.81000	0.00617	0.00697
1936.5081	61.50	1.02000	0.80000	0.00636	0.00822	2017.7419	62.20	1.01000	0.81000	0.00618	0.00697
1937.7190	61.53	1.02000	0.80000	0.00635	0.00787	2019.0630	62.29	1.01000	0.80000	0.00624	0.00830
1938.9220	61.46	1.02000	0.79000	0.00637	0.00761	2020.2111	62.15	1.01000	0.81000	0.00623	0.00791
1940.2419	61.13	1.02000	0.81000	0.00639	0.00742	2021.3669	62.29	1.01000	0.81000	0.00617	0.00764
1941.3979	61.57	1.02000	0.82000	0.00636	0.00730	2022.7419	62.24	1.01000	0.81000	0.00614	0.00744
1942.5470	61.59	1.02000	0.78000	0.00637	0.00721	2023.8910	62.46	1.01000	0.80000	0.00621	0.00927
1943.9220	61.64	1.02000	0.79000	0.00640	0.00895	2025.1021	62.35	1.01000	0.81000	0.00622	0.00860
1945.0780	61.53	1.02000	0.78000	0.00640	0.00838	2026.2581	62.27	1.01000	0.82000	0.00617	0.00815
1946.2810	61.46	1.02000	0.81000	0.00641	0.00798	2027.6331	62.35	1.01000	0.79000	0.00615	0.00778
1947.4380	61.48	1.02000	0.80000	0.00640	0.00770	2028.7810	62.35	1.01000	0.80000	0.00621	0.00960
1948.8130	63.14	1.02000	0.80000	0.00634	0.00748	2029.9919	62.27	1.01000	0.83000	0.00619	0.00885
1950.0229	62.26	1.02000	0.81000	0.00631	0.00733	2031.3130	62.27	1.01000	0.81000	0.00615	0.00826
1951.2810	61.64	1.02000	0.81000	0.00636	0.00722	2032.5229	62.42	1.01000	0.79000	0.00620	0.00790
1952.5470	61.62	1.02000	0.79000	0.00633	0.00714	2033.6720	62.33	1.01000	0.81000	0.00619	0.00765
1953.7500	61.62	1.02000	0.80000	0.00629	0.00709	2035.0389	62.40	1.01000	0.81000	0.00620	0.00744
1954.9611	61.31	1.02000	0.81000	0.00628	0.00705	2036.2500	62.31	1.01000	0.81000	0.00618	0.00730
1956.3440	61.68	1.02000	0.78000	0.00635	0.00829	2037.4139	62.35	1.01000	0.81000	0.00618	0.00721
1957.4919	61.71	1.02000	0.81000	0.00635	0.00791	2038.6090	62.35	1.01000	0.82000	0.00616	0.00715
1958.7030	61.77	1.02000	0.79000	0.00634	0.00764	2039.9301	62.40	1.01000	0.82000	0.00614	0.00709
1959.9139	61.73	1.02000	0.78000	0.00633	0.00745	2041.2030	62.35	1.01000	0.79000	0.00613	0.00705
1961.2190	61.71	1.01000	0.82000	0.00632	0.00730	2042.3521	62.42	1.01000	0.80000	0.00615	0.00703
1962.4301	61.64	1.02000	0.81000	0.00628	0.00720	2043.7190	62.60	1.01000	0.80000	0.00617	0.00701
1963.6410	61.93	1.02000	0.81000	0.00627	0.00714	2044.8831	62.35	1.01000	0.81000	0.00613	0.00700
1964.9611	61.73	1.02000	0.81000	0.00626	0.00708	2046.0780	62.42	1.01000	0.80000	0.00612	0.00698
1966.1720	61.75	1.02000	0.80000	0.00633	0.00916	2047.2419	62.40	1.01000	0.81000	0.00611	0.00698
1967.3199	61.42	1.02000	0.78000	0.00634	0.00851	2048.5630	62.35	1.01000	0.79000	0.00611	0.00697
1968.5310	61.79	1.02000	0.82000	0.00628	0.00807	2049.8201	62.53	1.01000	0.81000	0.00610	0.00697
1969.8521	61.73	1.02000	0.79000	0.00628	0.00773	2050.9690	62.49	1.01000	0.79000	0.00610	0.00696
1971.0630	61.84	1.02000	0.81000	0.00634	0.00894	2052.3440	62.49	1.01000	0.80000	0.00609	0.00696
1972.2581	61.73	1.02000	0.81000	0.00629	0.00834	2053.5000	62.51	1.01000	0.79000	0.00608	0.00696
1973.5780	61.86	1.02000	0.80000	0.00626	0.00791	2054.7109	62.58	1.01000	0.82000	0.00606	0.00696
1974.7889	61.79	1.02000	0.79000	0.00631	0.00765	2056.0229	62.60	1.01000	0.81000	0.00607	0.00696
1976.0000	61.82	1.01000	0.81000	0.00634	0.00908	2057.2339	62.62	1.00000	0.82000	0.00606	0.00696
1977.3199	61.82	1.02000	0.82000	0.00629	0.00841	2058.3911	62.67	1.01000	0.80000	0.00608	0.00695
1978.5310	61.79	1.02000	0.79000	0.00629	0.00801	2059.6021	62.58	1.01000	0.79000	0.00613	0.00879
1979.6801	61.82	1.01000	0.80000	0.00635	0.00970	2060.9141	62.58	1.01000	0.82000	0.00610	0.00821
1980.8910	61.80	1.01000	0.79000	0.00635	0.00891	2062.0701	62.56	1.01000	0.80000	0.00609	0.00785
1982.2111	61.75	1.01000	0.81000	0.00628	0.00832	2063.2810	62.51	1.01000	0.80000	0.00606	0.00761
1983.4139	61.66	1.01000	0.80000	0.00624	0.00794	2064.5940	62.71	1.01000	0.81000	0.00608	0.00740
1984.5699	60.44	1.01000	0.78000	0.00631	0.00962	2065.7971	62.60	1.00000	0.79000	0.00606	0.00728
1985.9380	61.88	1.01000	0.79000	0.00632	0.00878	2066.9609	62.65	1.00000	0.79000	0.00605	0.00719
1987.0940	61.91	1.01000	0.82000	0.00627	0.00827	2068.2729	62.65	1.00000	0.82000	0.00605	0.00712
1988.2500	61.88	1.01000	0.81000	0.00624	0.00791	2069.4839	62.69	1.00000	0.81000	0.00605	0.00707
1989.6169	61.93	1.01000	0.79000	0.00631	0.00967	2070.6411	62.69	1.00000	0.80000	0.00605	0.00704
1990.7729	61.88	1.01000	0.81000	0.00632	0.00889	2071.8440	62.69	1.00000	0.82000	0.00605	0.00701
1991.9840	61.88	1.01000	0.82000	0.00625	0.00835	2073.1641	62.58	1.00000	0.82000	0.00604	0.00700
1993.1410	61.95	1.01000	0.78000	0.00626	0.00797	2074.3201	62.69	1.00000	0.81000	0.00606	0.00699
1994.5081	61.88	1.01000	0.80000	0.00632	0.00890	2075.5229	63.11	1.00000	0.81000	0.00604	0.00698
1995.7190	61.95	1.01000	0.80000	0.00633	0.00833	2076.8440	62.82	1.00000	0.80000	0.00602	0.00697
1996.8669	61.93	1.01000	0.82000	0.00629	0.00795	2078.0471	62.69	1.00000	0.80000	0.00600	0.00697
1998.2419	61.86	1.01000	0.78000	0.00632	0.00765	2079.2029	62.65	1.00000	0.79000	0.00600	0.00696
1999.3979	61.73	1.01000	0.81000	0.00633	0.00746	2080.5779	62.74	1.00000	0.79000	0.00600	0.00696
2000.6090	61.91	1.01000	0.81000	0.00631	0.00733	2081.7339	62.78	1.01000	0.81000	0.00600	0.00696
2001.9220	61.84	1.01000	0.80000	0.00624	0.00722	2082.9380	62.67	1.01000	0.82000	0.00601	0.00696
2003.1331	61.95	1.01000	0.79000	0.00625	0.00715	2084.0940	62.65	1.00000	0.81000	0.00601	0.00696
2004.2889	62.00	1.01000	0.81000	0.00628	0.00710	2085.4141	62.74	1.00000	0.79000	0.00601	0.00695

2086.6169	62.65	1.00000	0.79000	0.00604	0.00695	2167.9609	63.41	0.99000	0.82000	0.00573	0.00694
2087.8831	62.74	1.00000	0.81000	0.00601	0.00695	2169.1169	63.23	0.99000	0.81000	0.00572	0.00694
2089.1479	62.67	1.00000	0.81000	0.00600	0.00695	2170.3201	63.30	0.99000	0.81000	0.00572	0.00694
2090.3521	62.71	1.00000	0.81000	0.00600	0.00695	2171.4839	63.70	0.99000	0.81000	0.00572	0.00696
2091.5630	62.76	1.00000	0.81000	0.00600	0.00695	2172.7971	63.36	0.99000	0.80000	0.00574	0.00694
2092.7190	62.78	1.00000	0.80000	0.00598	0.00695	2173.9529	63.34	0.99000	0.81000	0.00575	0.00694
2094.0940	62.76	1.00000	0.81000	0.00598	0.00695	2175.1641	63.38	0.99000	0.81000	0.00575	0.00693
2095.2419	62.80	1.00000	0.82000	0.00597	0.00695	2176.4839	63.36	0.99000	0.81000	0.00575	0.00694
2096.4529	62.80	1.00000	0.81000	0.00597	0.00695	2177.6799	63.25	0.99000	0.81000	0.00576	0.00694
2097.7729	62.98	1.00000	0.80000	0.00598	0.00695	2178.8440	63.36	0.99000	0.81000	0.00577	0.00694
2098.9839	62.65	1.00000	0.81000	0.00599	0.00695	2180.1641	63.34	0.99000	0.81000	0.00577	0.00695
2100.1880	62.80	1.00000	0.80000	0.00599	0.00695	2181.3589	63.27	0.99000	0.80000	0.00579	0.00695
2101.5000	62.78	1.00000	0.81000	0.00598	0.00696	2182.5701	63.34	0.99000	0.81000	0.00579	0.00695
2102.7109	62.74	1.00000	0.81000	0.00598	0.00695	2183.7339	63.30	0.99000	0.80000	0.00579	0.00695
2103.9221	62.91	1.00000	0.79000	0.00599	0.00695	2185.1021	63.43	0.99000	0.81000	0.00577	0.00695
2105.1331	62.83	1.00000	0.79000	0.00598	0.00695	2186.2500	63.38	0.99000	0.80000	0.00577	0.00695
2106.5000	62.87	1.00000	0.81000	0.00596	0.00696	2187.4609	63.30	0.99000	0.81000	0.00576	0.00696
2107.6479	62.78	1.00000	0.82000	0.00595	0.00696	2188.7810	63.38	0.99000	0.82000	0.00576	0.00695
2108.8589	62.83	1.00000	0.79000	0.00594	0.00697	2189.9919	63.32	0.99000	0.81000	0.00575	0.00695
2110.1799	62.89	1.00000	0.82000	0.00592	0.00697	2191.1411	63.34	0.99000	0.81000	0.00577	0.00694
2111.3279	62.94	1.00000	0.80000	0.00592	0.00697	2192.4609	63.43	0.99000	0.81000	0.00577	0.00694
2112.5391	62.91	1.00000	0.80000	0.00592	0.00697	2193.6721	63.30	0.99000	0.80000	0.00580	0.00694
2113.8589	62.98	1.00000	0.82000	0.00590	0.00696	2194.8201	63.43	1.00000	0.80000	0.00581	0.00694
2115.0081	62.98	1.00000	0.80000	0.00592	0.00697	2196.0310	63.50	0.99000	0.81000	0.00582	0.00694
2116.2190	62.94	1.00000	0.80000	0.00590	0.00696	2197.3521	63.36	1.00000	0.81000	0.00580	0.00696
2117.3831	62.89	1.00000	0.82000	0.00591	0.00696	2198.5000	63.45	0.99000	0.81000	0.00578	0.00695
2118.6880	62.94	1.00000	0.80000	0.00590	0.00696	2199.6641	63.52	1.00000	0.81000	0.00578	0.00694
2119.8979	62.96	1.00000	0.81000	0.00590	0.00696	2201.0310	63.48	0.99000	0.81000	0.00580	0.00694
2121.0630	61.30	1.00000	0.80000	0.00591	0.00696	2202.2419	63.39	0.99000	0.81000	0.00580	0.00694
2122.4299	63.00	1.00000	0.81000	0.00590	0.00695	2203.4380	63.63	0.99000	0.81000	0.00579	0.00695
2123.5779	62.98	1.00000	0.82000	0.00590	0.00695	2204.6021	63.48	0.99000	0.81000	0.00576	0.00694
2124.7419	62.96	1.00000	0.79000	0.00590	0.00695	2205.9221	63.61	0.99000	0.80000	0.00575	0.00696
2125.9529	63.05	1.00000	0.81000	0.00592	0.00695	2207.0701	63.68	0.99000	0.82000	0.00574	0.00696
2127.2581	62.96	1.00000	0.80000	0.00589	0.00695	2208.2810	63.59	0.99000	0.81000	0.00574	0.00695
2128.4690	62.96	1.00000	0.80000	0.00590	0.00695	2209.6021	63.68	0.99000	0.81000	0.00573	0.00694
2129.6331	63.05	1.00000	0.81000	0.00590	0.00695	2210.7500	63.50	0.99000	0.82000	0.00569	0.00694
2131.0000	63.07	1.00000	0.78000	0.00588	0.00695	2211.9609	63.61	0.99000	0.81000	0.00569	0.00693
2132.1479	63.11	1.00000	0.82000	0.00586	0.00695	2213.3279	63.68	0.99000	0.81000	0.00569	0.00693
2133.3589	63.07	1.00000	0.82000	0.00581	0.00695	2214.4839	63.74	0.99000	0.81000	0.00568	0.00693
2134.6799	63.03	1.00000	0.81000	0.00578	0.00695	2215.6411	63.68	0.99000	0.82000	0.00566	0.00693
2135.8911	62.94	1.00000	0.82000	0.00576	0.00694	2216.8521	63.68	0.99000	0.81000	0.00567	0.00695
2137.0391	63.25	1.00000	0.81000	0.00577	0.00694	2218.1641	63.81	0.99000	0.81000	0.00568	0.00695
2138.2971	62.98	1.00000	0.80000	0.00582	0.00694	2219.3669	63.79	0.99000	0.81000	0.00569	0.00696
2139.6169	63.09	1.00000	0.82000	0.00587	0.00695	2220.5779	63.83	0.99000	0.82000	0.00564	0.00696
2140.8279	63.09	1.00000	0.79000	0.00588	0.00695	2221.8440	63.90	0.99000	0.81000	0.00563	0.00696
2142.0391	63.16	1.00000	0.82000	0.00588	0.00696	2223.0471	63.81	0.99000	0.81000	0.00564	0.00696
2143.3589	63.14	1.00000	0.80000	0.00587	0.00695	2224.2109	63.92	0.99000	0.81000	0.00563	0.00697
2144.5630	63.16	1.00000	0.82000	0.00588	0.00694	2225.5310	63.79	0.99000	0.81000	0.00563	0.00697
2145.7190	63.14	1.00000	0.78000	0.00589	0.00694	2226.7339	63.81	0.99000	0.81000	0.00564	0.00697
2147.0391	63.25	1.00000	0.82000	0.00590	0.00695	2227.8911	63.85	0.99000	0.81000	0.00561	0.00697
2148.2419	63.16	1.00000	0.79000	0.00590	0.00695	2229.1021	63.94	0.99000	0.81000	0.00558	0.00697
2149.4529	63.18	1.00000	0.82000	0.00586	0.00694	2230.4141	63.99	0.99000	0.81000	0.00556	0.00696
2150.6089	62.92	1.00000	0.79000	0.00582	0.00694	2231.6169	64.10	0.99000	0.81000	0.00556	0.00697
2151.9221	63.25	1.00000	0.82000	0.00584	0.00694	2232.7810	64.04	0.99000	0.82000	0.00555	0.00697
2153.1331	63.23	0.99000	0.81000	0.00585	0.00694	2234.1479	64.06	0.99000	0.82000	0.00553	0.00696
2154.3979	63.25	0.99000	0.81000	0.00587	0.00694	2235.2971	64.12	0.99000	0.81000	0.00554	0.00696
2155.7109	63.30	0.99000	0.79000	0.00586	0.00694	2236.5081	64.15	0.99000	0.81000	0.00558	0.00696
2156.9221	63.25	0.99000	0.80000	0.00586	0.00694	2237.8279	64.06	0.99000	0.81000	0.00556	0.00696
2158.0779	63.36	0.99000	0.81000	0.00584	0.00694	2239.0391	64.17	0.98000	0.82000	0.00553	0.00696
2159.3911	63.34	0.99000	0.82000	0.00584	0.00694	2240.1880	64.17	0.99000	0.82000	0.00551	0.00696
2160.6021	63.39	0.99000	0.80000	0.00584	0.00694	2241.3979	64.28	0.99000	0.81000	0.00551	0.00696
2161.8130	63.25	1.00000	0.82000	0.00582	0.00694	2242.7190	64.24	0.99000	0.82000	0.00551	0.00696
2162.9609	63.45	0.99000	0.81000	0.00582	0.00694	2243.9299	64.26	0.99000	0.81000	0.00551	0.00696
2164.2810	63.27	0.99000	0.80000	0.00575	0.00693	2245.0779	64.19	0.99000	0.81000	0.00552	0.00696
2165.4919	63.21	0.99000	0.81000	0.00578	0.00694	2246.4529	64.28	0.99000	0.82000	0.00551	0.00696
2166.6411	63.27	0.99000	0.81000	0.00575	0.00694	2247.6089	64.30	0.99000	0.82000	0.00549	0.00696

2248.8130	64.26	0.99000	0.83000	0.00545	0.00696	2331.1479	67.01	0.98000	0.86000	0.00450	0.12264
2249.9690	64.46	0.99000	0.82000	0.00541	0.00696	2332.4141	67.16	0.98000	0.86000	0.00449	0.12430
2251.3440	64.30	0.99000	0.82000	0.00540	0.00696	2333.6169	67.05	0.98000	0.86000	0.00448	0.12523
2252.4919	64.37	0.99000	0.82000	0.00539	0.00696	2334.9919	67.19	0.98000	0.86000	0.00447	0.12540
2253.7029	64.39	0.99000	0.83000	0.00537	0.00696	2336.2500	67.32	0.98000	0.86000	0.00445	0.12762
2255.0229	64.50	0.99000	0.82000	0.00534	0.00696	2337.4609	67.28	0.98000	0.86000	0.00443	0.12913
2256.1721	64.37	0.99000	0.83000	0.00533	0.00696	2338.8440	67.45	0.98000	0.86000	0.00441	0.13174
2257.3831	64.44	0.99000	0.82000	0.00533	0.00696	2340.0391	67.43	0.98000	0.86000	0.00441	0.13271
2258.7029	64.53	0.99000	0.83000	0.00532	0.00696	2341.3130	67.50	0.98000	0.86000	0.00441	0.13306
2259.9141	64.55	0.98000	0.82000	0.00531	0.00696	2342.5229	67.52	0.98000	0.86000	0.00442	0.13278
2261.0630	64.31	0.98000	0.82000	0.00530	0.00696	2343.9380	67.66	0.98000	0.86000	0.00441	0.13288
2262.2729	64.55	0.98000	0.82000	0.00529	0.00696	2345.1479	67.68	0.98000	0.86000	0.00440	0.13206
2263.5940	62.41	0.98000	0.83000	0.00527	0.00696	2346.4221	67.74	0.98000	0.86000	0.00437	0.13281
2264.7419	64.53	0.98000	0.83000	0.00525	0.00695	2347.7891	67.74	0.98000	0.86000	0.00433	0.13489
2265.9529	64.71	0.98000	0.82000	0.00525	0.00695	2349.0471	67.81	0.98000	0.86000	0.00431	0.13628
2267.3201	64.66	0.98000	0.82000	0.00526	0.00695	2350.2109	68.01	0.98000	0.87000	0.00429	0.13762
2268.4839	64.57	0.98000	0.82000	0.00527	0.00695	2351.5779	68.06	0.98000	0.87000	0.00424	0.13941
2269.6331	64.39	0.98000	0.82000	0.00528	0.00695	2352.8440	68.01	0.98000	0.87000	0.00422	0.14069
2271.0000	64.82	0.98000	0.82000	0.00529	0.00695	2354.0471	68.08	0.98000	0.87000	0.00421	0.14112
2272.1641	64.71	0.98000	0.82000	0.00528	0.00695	2355.3130	68.21	0.98000	0.87000	0.00420	0.14097
2273.3669	64.91	0.98000	0.83000	0.00526	0.00695	2356.6331	68.30	0.98000	0.87000	0.00419	0.14063
2274.5229	64.86	0.99000	0.83000	0.00524	0.00724	2357.7891	68.37	0.98000	0.87000	0.00419	0.14051
2275.8440	65.04	0.98000	0.83000	0.00521	0.00838	2358.9380	68.50	0.98000	0.87000	0.00418	0.14097
2276.9919	64.84	0.98000	0.83000	0.00517	0.01219	2360.3130	68.57	0.98000	0.87000	0.00417	0.14167
2278.2029	64.98	0.98000	0.83000	0.00517	0.01280	2361.4690	68.55	0.98000	0.87000	0.00417	0.14233
2279.5229	64.93	0.98000	0.83000	0.00515	0.01160	2362.6169	68.70	0.98000	0.87000	0.00415	0.14215
2280.7339	65.00	0.98000	0.83000	0.00516	0.01032	2363.8279	68.64	0.98000	0.87000	0.00412	0.14329
2281.8831	65.00	0.98000	0.83000	0.00515	0.01111	2365.2029	68.66	0.98000	0.87000	0.00409	0.14460
2283.0940	65.04	0.98000	0.83000	0.00513	0.01711	2366.3521	68.77	0.98000	0.87000	0.00407	0.14480
2284.4141	65.00	0.98000	0.83000	0.00513	0.01611	2367.5630	68.93	0.98000	0.87000	0.00405	0.14595
2285.6089	65.11	0.98000	0.83000	0.00513	0.01354	2368.8279	68.93	0.98000	0.88000	0.00403	0.14698
2286.7729	65.07	0.98000	0.83000	0.00511	0.01482	2369.9839	68.95	0.98000	0.88000	0.00400	0.14848
2288.1411	65.18	0.98000	0.83000	0.00509	0.02060	2371.1880	69.01	0.98000	0.88000	0.00399	0.14864
2289.3521	65.24	0.98000	0.83000	0.00509	0.01818	2372.5081	69.01	0.98000	0.88000	0.00398	0.14968
2290.6089	65.31	0.98000	0.83000	0.00509	0.01766	2373.6641	69.13	0.98000	0.88000	0.00396	0.15034
2291.9299	65.40	0.98000	0.83000	0.00507	0.01662	2374.8669	69.22	0.98000	0.88000	0.00395	0.15102
2293.1411	65.31	0.98000	0.83000	0.00507	0.01831	2376.0229	69.19	0.98000	0.88000	0.00393	0.15163
2294.3979	65.47	0.98000	0.83000	0.00508	0.01542	2377.3911	69.22	0.98000	0.88000	0.00391	0.15172
2295.6089	65.40	0.98000	0.83000	0.00507	0.01952	2378.5471	69.24	0.98000	0.88000	0.00390	0.15187
2296.9299	65.56	0.98000	0.84000	0.00505	0.02037	2379.7029	69.33	0.98000	0.88000	0.00388	0.15218
2298.1880	65.54	0.98000	0.84000	0.00502	0.02904	2381.0701	66.63	0.98000	0.88000	0.00387	0.15229
2299.3979	65.65	0.98000	0.84000	0.00500	0.04095	2382.2339	69.44	0.98000	0.88000	0.00385	0.15209
2300.7190	65.67	0.98000	0.83000	0.00500	0.04027	2383.4380	69.39	0.97000	0.88000	0.00383	0.15256
2301.9839	65.74	0.98000	0.83000	0.00501	0.03456	2384.7500	69.53	0.97000	0.88000	0.00382	0.15261
2303.1880	65.87	0.98000	0.84000	0.00498	0.03339	2385.9609	69.53	0.97000	0.88000	0.00381	0.15237
2304.5630	65.89	0.98000	0.84000	0.00495	0.04947	2387.1169	69.13	0.97000	0.88000	0.00381	0.15248
2305.7729	65.03	0.98000	0.84000	0.00493	0.05468	2388.3201	69.55	0.98000	0.88000	0.00381	0.15272
2306.9839	65.98	0.98000	0.84000	0.00492	0.05410	2389.6411	69.71	0.97000	0.88000	0.00379	0.15365
2308.2419	65.96	0.98000	0.84000	0.00490	0.06308	2390.7971	69.77	0.97000	0.88000	0.00379	0.15355
2309.6169	66.09	0.98000	0.84000	0.00488	0.06961	2392.0000	69.82	0.98000	0.88000	0.00378	0.15318
2310.7729	66.05	0.98000	0.84000	0.00486	0.07723	2393.3201	69.84	0.98000	0.88000	0.00377	0.15403
2312.0310	66.14	0.98000	0.84000	0.00485	0.08302	2394.5310	69.93	0.98000	0.88000	0.00377	0.15436
2313.3521	66.23	0.98000	0.85000	0.00482	0.08831	2395.7419	69.86	0.98000	0.88000	0.00377	0.15437
2314.5630	66.25	0.98000	0.85000	0.00476	0.09706	2397.0000	70.00	0.98000	0.88000	0.00376	0.15517
2315.8201	66.18	0.98000	0.85000	0.00472	0.10325	2398.2109	70.07	0.98000	0.88000	0.00374	0.15567
2317.2029	66.30	0.98000	0.85000	0.00468	0.10908	2399.3589	70.09	0.98000	0.88000	0.00374	0.15519
2318.3979	66.41	0.98000	0.85000	0.00463	0.11264	2400.5701	69.89	0.98000	0.88000	0.00373	0.15565
2319.6721	66.45	0.98000	0.85000	0.00460	0.11487	2401.8911	70.07	0.98000	0.89000	0.00372	0.15648
2320.8831	66.54	0.98000	0.85000	0.00459	0.11639	2403.0391	70.62	0.98000	0.89000	0.00370	0.15679
2322.2500	66.56	0.98000	0.85000	0.00458	0.11807	2404.2500	70.27	0.98000	0.89000	0.00368	0.15716
2323.4609	66.56	0.98000	0.85000	0.00456	0.11933	2405.6331	70.27	0.97000	0.88000	0.00366	0.15749
2324.7190	66.70	0.98000	0.85000	0.00455	0.11952	2406.7810	70.40	0.97000	0.88000	0.00365	0.15744
2326.0940	66.65	0.98000	0.85000	0.00455	0.11541	2407.9299	74.23	0.98000	0.89000	0.00365	0.15737
2327.3589	66.81	0.98000	0.85000	0.00454	0.11893	2409.1411	70.38	0.98000	0.88000	0.00365	0.15744
2328.5701	66.76	0.98000	0.86000	0.00452	0.12180	2410.4609	70.54	0.97000	0.88000	0.00363	0.15778
2329.8279	66.85	0.98000	0.85000	0.00452	0.12286	2411.6721	70.61	0.97000	0.89000	0.00362	0.15771



2412.8831	70.63	0.97000	0.89000	0.00361	0.15797	2493.3440	72.46	0.97000	0.90000	0.00317	0.16876
2414.1880	70.83	0.97000	0.89000	0.00360	0.15840	2494.5471	72.73	0.97000	0.90000	0.00315	0.16892
2415.3521	70.74	0.97000	0.89000	0.00360	0.15850	2495.8669	72.48	0.97000	0.90000	0.00312	0.16905
2416.5630	70.90	0.97000	0.89000	0.00359	0.15822	2497.0229	72.51	0.97000	0.90000	0.00311	0.16907
2417.8669	70.96	0.97000	0.89000	0.00359	0.15834	2498.1799	72.53	0.98000	0.90000	0.00309	0.16893
2419.0310	70.96	0.97000	0.89000	0.00360	0.15833	2499.3831	72.62	0.97000	0.90000	0.00307	0.16964
2420.1799	70.87	0.97000	0.89000	0.00360	0.15874	2500.6479	72.73	0.97000	0.91000	0.00306	0.16986
2421.3911	71.05	0.97000	0.89000	0.00360	0.15863	2501.8589	72.69	0.97000	0.91000	0.00304	0.17036
2422.6479	71.12	0.97000	0.89000	0.00360	0.15862	2503.0081	72.82	0.97000	0.91000	0.00303	0.17128
2423.8589	71.01	0.98000	0.89000	0.00360	0.15880	2504.3831	72.80	0.97000	0.91000	0.00301	0.17127
2425.0081	71.12	0.97000	0.89000	0.00360	0.15815	2505.5391	72.78	0.97000	0.91000	0.00299	0.17234
2426.3279	71.12	0.98000	0.89000	0.00359	0.15899	2506.7419	72.78	0.98000	0.91000	0.00298	0.17216
2427.4919	71.12	0.97000	0.89000	0.00358	0.15882	2508.0630	72.91	0.97000	0.91000	0.00296	0.17238
2428.6411	71.12	0.97000	0.89000	0.00358	0.15875	2509.2190	72.98	0.98000	0.91000	0.00295	0.17309
2429.9609	71.17	0.97000	0.89000	0.00358	0.15915	2510.4221	73.05	0.98000	0.91000	0.00294	0.17345
2431.1089	71.10	0.97000	0.89000	0.00357	0.15904	2511.6331	72.34	0.97000	0.91000	0.00293	0.17425
2432.3201	71.14	0.98000	0.89000	0.00356	0.15919	2512.9529	73.09	0.97000	0.91000	0.00290	0.17456
2433.4221	71.21	0.97000	0.89000	0.00356	0.15930	2514.1641	73.20	0.97000	0.91000	0.00289	0.17474
2434.7891	71.25	0.98000	0.89000	0.00356	0.15899	2515.3130	73.16	0.98000	0.91000	0.00288	0.17521
2435.9380	71.25	0.98000	0.89000	0.00356	0.15963	2516.6331	72.56	0.97000	0.91000	0.00286	0.17452
2437.1479	71.14	0.97000	0.89000	0.00355	0.15962	2517.7810	73.83	0.97000	0.91000	0.00285	0.17462
2438.4690	71.23	0.97000	0.89000	0.00355	0.16039	2518.9919	73.32	0.97000	0.91000	0.00284	0.17534
2439.6799	68.47	0.97000	0.89000	0.00354	0.16049	2520.1479	73.29	0.97000	0.91000	0.00283	0.17541
2440.8279	71.23	0.97000	0.89000	0.00353	0.16028	2521.5229	73.49	0.97000	0.91000	0.00282	0.17559
2442.0391	71.34	0.97000	0.89000	0.00353	0.16081	2522.6721	73.47	0.97000	0.91000	0.00281	0.17609
2443.3589	71.30	0.97000	0.89000	0.00352	0.16079	2523.8831	73.45	0.97000	0.91000	0.00280	0.17617
2444.5081	71.23	0.97000	0.89000	0.00350	0.16094	2525.2029	73.47	0.97000	0.91000	0.00278	0.17680
2445.7190	71.27	0.97000	0.89000	0.00350	0.16075	2526.4141	73.58	0.97000	0.91000	0.00278	0.17736
2447.0391	71.32	0.97000	0.89000	0.00348	0.16067	2527.5630	73.65	0.97000	0.91000	0.00277	0.17709
2448.2500	71.39	0.97000	0.89000	0.00347	0.16056	2528.8831	72.77	0.97000	0.91000	0.00277	0.17685
2449.3979	71.37	0.98000	0.89000	0.00347	0.16111	2530.0940	73.72	0.97000	0.91000	0.00276	0.17697
2450.7729	71.39	0.98000	0.89000	0.00346	0.16161	2531.2971	73.78	0.97000	0.91000	0.00275	0.17766
2451.9299	71.41	0.98000	0.89000	0.00346	0.16208	2532.3911	73.81	0.97000	0.91000	0.00274	0.17785
2453.0779	71.43	0.97000	0.89000	0.00345	0.16286	2533.7109	73.78	0.97000	0.91000	0.00272	0.17831
2454.2891	71.52	0.98000	0.89000	0.00346	0.16288	2534.9221	73.98	0.97000	0.91000	0.00271	0.17852
2455.6089	71.50	0.97000	0.89000	0.00345	0.16336	2536.0701	74.01	0.97000	0.92000	0.00271	0.17896
2456.7581	71.48	0.98000	0.89000	0.00344	0.16299	2537.4529	74.03	0.97000	0.92000	0.00270	0.17888
2457.9141	71.50	0.98000	0.89000	0.00344	0.16289	2538.6021	74.12	0.97000	0.92000	0.00269	0.17881
2459.2891	71.52	0.98000	0.89000	0.00344	0.16322	2539.7500	74.16	0.98000	0.92000	0.00271	0.17887
2460.4380	71.48	0.98000	0.89000	0.00344	0.16328	2541.1331	74.27	0.98000	0.92000	0.00271	0.17918
2461.6479	71.63	0.98000	0.89000	0.00343	0.16359	2542.2810	74.25	0.98000	0.92000	0.00270	0.17951
2462.9690	71.57	0.98000	0.89000	0.00342	0.16369	2543.4919	74.36	0.98000	0.92000	0.00270	0.17993
2464.1799	71.61	0.98000	0.89000	0.00342	0.16381	2544.6411	74.36	0.98000	0.92000	0.00269	0.18020
2465.3279	71.61	0.98000	0.89000	0.00342	0.16386	2545.9609	74.43	0.98000	0.92000	0.00269	0.18095
2466.5391	71.68	0.97000	0.89000	0.00340	0.16355	2547.1721	74.56	0.98000	0.92000	0.00269	0.18069
2467.7971	71.68	0.98000	0.90000	0.00340	0.16408	2548.3831	74.63	0.98000	0.92000	0.00268	0.18079
2469.0081	71.77	0.98000	0.90000	0.00338	0.16419	2549.6411	74.61	0.98000	0.92000	0.00267	0.18156
2470.1641	71.52	0.97000	0.90000	0.00338	0.16440	2550.8521	74.61	0.98000	0.92000	0.00267	0.18124
2471.4839	71.79	0.98000	0.90000	0.00337	0.16483	2552.0000	74.70	0.98000	0.92000	0.00267	0.18147
2472.6880	71.77	0.97000	0.90000	0.00335	0.16501	2553.3201	74.81	0.98000	0.92000	0.00266	0.18152
2473.8979	71.97	0.97000	0.90000	0.00335	0.16490	2554.5310	74.97	0.98000	0.92000	0.00265	0.18132
2475.1641	71.79	0.97000	0.90000	0.00333	0.16463	2555.6799	74.94	0.97000	0.92000	0.00262	0.18160
2476.3669	71.79	0.97000	0.90000	0.00332	0.16495	2556.8911	74.99	0.97000	0.92000	0.00259	0.18129
2477.5229	71.88	0.98000	0.90000	0.00332	0.16546	2558.2109	75.03	0.97000	0.92000	0.00257	0.18105
2478.6799	71.95	0.98000	0.90000	0.00331	0.16561	2559.4221	75.10	0.97000	0.92000	0.00256	0.18143
2479.9919	71.93	0.98000	0.90000	0.00331	0.16636	2560.5701	75.19	0.97000	0.92000	0.00254	0.18093
2481.1479	71.97	0.98000	0.90000	0.00330	0.16688	2561.9380	75.81	0.97000	0.92000	0.00253	0.18074
2482.3589	71.04	0.98000	0.90000	0.00330	0.16683	2563.1021	75.14	0.97000	0.92000	0.00253	0.18048
2483.6721	72.08	0.98000	0.90000	0.00329	0.16699	2564.2500	75.30	0.97000	0.92000	0.00253	0.18012
2484.8279	71.97	0.98000	0.90000	0.00328	0.16708	2565.4609	75.46	0.97000	0.92000	0.00253	0.17988
2485.9839	72.19	0.97000	0.90000	0.00326	0.16772	2566.7810	75.39	0.97000	0.92000	0.00255	0.18037
2487.1880	72.19	0.97000	0.90000	0.00325	0.16747	2567.9299	75.52	0.97000	0.92000	0.00255	0.18033
2488.5630	72.06	0.97000	0.90000	0.00323	0.16729	2569.0779	75.54	0.97000	0.92000	0.00255	0.18040
2489.7190	72.37	0.97000	0.90000	0.00321	0.16772	2570.4609	75.57	0.97000	0.92000	0.00255	0.18105
2490.9221	72.44	0.97000	0.90000	0.00318	0.16807	2571.6089	75.68	0.97000	0.92000	0.00254	0.18107
2492.1880	72.26	0.97000	0.90000	0.00318	0.16867	2572.8201	75.77	0.97000	0.92000	0.00252	0.18068

2574.1411	75.79	0.97000	0.92000	0.00251	0.18023
2575.3521	75.74	0.97000	0.92000	0.00250	0.18014
2576.5000	75.86	0.97000	0.92000	0.00250	0.16521
2577.6479	76.10	0.97000	0.92000	0.00247	0.12215
2579.0310	75.88	0.97000	0.92000	0.00244	0.08717
2580.1799	76.13	0.97000	0.92000	0.00242	0.06537
2581.3911	76.06	0.97000	0.92000	0.00238	0.04998
2582.6479	76.01	0.97000	0.92000	0.00232	0.03758
2583.8589	76.03	0.97000	0.92000	0.00228	0.02967
2585.0081	76.15	0.97000	0.92000	0.00224	0.02376

## 2) GN021

Time	Tts	Psg(Pa)	Pts(Pa)	Ws	Winj
1.5900	29.88	143000.0	140579.0	0.00083	0.00710
What					
0.04125					
2.8520	29.93	143000.0	140579.0	0.00083	0.00710
0.04125					
4.1210	29.93	143000.0	140579.0	0.00083	0.00710
0.04125					
5.3790	29.86	143000.0	140579.0	0.00083	0.00710
0.04125					
6.8590	29.86	143000.0	140579.0	0.00083	0.00710
0.04125					
8.1210	29.88	143000.0	140579.0	0.00083	0.00710
0.04125					
9.3910	29.86	143000.0	140579.0	0.00083	0.01580
0.04125					
10.8200	29.91	143000.0	125246.0	0.00089	0.14470
0.10125					
12.1290	29.84	142000.0	123852.0	0.00094	0.21520
0.16500					
13.3980	29.84	143000.0	121065.0	0.00099	0.26100
0.21375					
14.6090	29.93	143000.0	119671.0	0.00101	0.28860
0.24750					
16.0310	30.06	142000.0	118277.0	0.00102	0.30910
0.22875					
17.3520	30.04	142000.0	116883.0	0.00105	0.31990
0.19500					
18.6210	30.17	142000.0	116883.0	0.00112	0.32800
0.17250					
20.0390	30.35	142000.0	116883.0	0.00142	0.33630
0.15750					
21.3090	30.41	142000.0	118277.0	0.00247	0.34160
0.14250					
22.6290	30.72	142000.0	122458.0	0.00337	0.34650
0.13875					
24.0510	31.16	142000.0	118277.0	0.00414	0.35010
0.13500					
25.3710	31.51	141000.0	119671.0	0.00465	0.35260
0.13500					
26.6910	32.20	141000.0	118277.0	0.00502	0.35390
0.13125					
27.9490	32.86	141000.0	118277.0	0.00531	0.35540
0.12750					
29.3280	33.39	141000.0	111307.0	0.00572	0.35140
0.12750					
30.5900	34.03	141000.0	111307.0	0.00613	0.34330
0.12750					
31.9100	34.35	141000.0	108520.0	0.00662	0.33120
0.12750					
33.3910	34.48	141000.0	104338.0	0.00713	0.31590
0.13125					
34.6480	34.63	140000.0	102944.0	0.00754	0.30350
0.13500					
35.8590	34.81	140000.0	102944.0	0.00786	0.29480
0.13500					
37.2890	35.14	141000.0	101550.0	0.00812	0.28360
0.13500					
38.5510	35.23	141000.0	101550.0	0.00844	0.27620
0.13500					
39.8710	35.16	141000.0	98763.0	0.00863	0.27180
0.13500					
41.1410	35.54	141000.0	101550.0	0.00886	0.26530

0.13500					
42.5590	35.64	140000.0	109914.0	0.00909	0.25980
0.13500					
43.8280	35.73	140000.0	105732.0	0.00918	0.25670
0.13125					
45.0900	35.93	140000.0	100157.0	0.00934	0.25340
0.13125					
46.5700	36.13	141000.0	109914.0	0.00955	0.25160
0.12750					
47.8400	36.20	140000.0	100157.0	0.00974	0.25060
0.13125					
49.1020	36.33	140000.0	109914.0	0.00974	0.25140
0.13125					
50.5310	36.55	141000.0	112701.0	0.00975	0.24950
0.13500					
51.8520	36.73	140000.0	114095.0	0.00974	0.24900
0.13500					
53.1090	36.77	140000.0	119671.0	0.00970	0.24810
0.13875					
54.4300	36.75	140000.0	116883.0	0.00974	0.24680
0.13500					
55.9100	36.97	141000.0	112701.0	0.00991	0.24730
0.13500					
57.2300	37.22	141000.0	119671.0	0.00993	0.24820
0.13875					
58.5510	37.44	141000.0	118277.0	0.00990	0.24880
0.13875					
59.9690	37.70	141000.0	118277.0	0.00987	0.24820
0.14250					
61.2380	37.75	141000.0	116883.0	0.00984	0.24770
0.13500					
62.5000	37.88	141000.0	119671.0	0.00982	0.24920
0.13500					
63.9800	37.90	141000.0	121065.0	0.00976	0.25070
0.13875					
65.2500	37.93	140000.0	121065.0	0.00966	0.25120
0.13500					
66.5120	37.97	140000.0	121065.0	0.00968	0.25300
0.13125					
67.7190	37.99	140000.0	116883.0	0.00972	0.25390
0.13125					
69.1480	38.04	140000.0	122458.0	0.00972	0.25420
0.13125					
70.4690	38.15	140000.0	123852.0	0.00974	0.25430
0.12750					
71.7300	38.39	140000.0	118277.0	0.00981	0.25220
0.12750					
73.1600	38.50	141000.0	128034.0	0.00976	0.25170
0.12750					
74.4220	38.77	140000.0	129428.0	0.00971	0.25350
0.12750					
75.7380	38.85	140000.0	132216.0	0.00964	0.25280
0.13125					
77.1720	39.12	140000.0	126640.0	0.00969	0.25330
0.12750					
78.4300	39.36	140000.0	128034.0	0.00969	0.25790
0.12750					
79.6910	39.63	140000.0	130822.0	0.00963	0.25580
0.13125					
81.0120	39.83	140000.0	135003.0	0.00967	0.25550
0.13125					
82.4880	39.87	140000.0	129428.0	0.00969	0.25560
0.13125					
83.8090	39.94	140000.0	129428.0	0.00971	0.25330
0.12750					
85.1290	40.25	139000.0	135003.0	0.00964	0.25410



0.12750					
86.5590	40.49	139000.0	125246.0	0.00963	0.25380
0.12750					
87.8200	40.49	139000.0	129428.0	0.00964	0.25290
0.12750					
89.1410	40.67	139000.0	130822.0	0.00963	0.25150
0.12750					
90.6210	40.78	140000.0	128034.0	0.00974	0.25230
0.13125					
91.8280	41.09	140000.0	130822.0	0.00978	0.25050
0.13125					
93.1480	41.35	139000.0	129428.0	0.00977	0.25010
0.13500					
94.4690	41.48	140000.0	147548.0	0.00976	0.24970
0.13125					
95.8980	41.62	139000.0	133609.0	0.00973	0.24810
0.13500					
97.1600	41.64	139000.0	135003.0	0.00975	0.24770
0.13125					
98.4220	41.62	139000.0	129428.0	0.00979	0.24850
0.13125					
99.8010	41.84	139000.0	129428.0	0.00985	0.24970
0.13125					
101.1090	41.93	139000.0	136397.0	0.00986	0.24730
0.13125					
102.4300	42.01	139000.0	128034.0	0.00979	0.24720
0.13125					
103.8590	42.12	139000.0	130822.0	0.00995	0.24440
0.13875					
105.1210	42.21	139000.0	130822.0	0.00999	0.24360
0.13875					
106.4410	42.50	139000.0	130822.0	0.01004	0.24360
0.14250					
107.6990	42.68	139000.0	133609.0	0.00996	0.24430
0.13500					
109.1290	42.99	139000.0	132216.0	0.00990	0.24490
0.13500					
110.4490	42.92	139000.0	137791.0	0.00985	0.24490
0.13875					
111.7110	42.92	139000.0	133609.0	0.00984	0.24670
0.14250					
113.1410	42.90	139000.0	130822.0	0.00987	0.24640
0.14250					
114.4100	43.03	139000.0	126640.0	0.00989	0.24640
0.14250					
115.7190	43.08	139000.0	130822.0	0.00999	0.24510
0.14625					
117.0390	43.21	139000.0	130822.0	0.01002	0.24360
0.14250					
118.4220	43.36	139000.0	132216.0	0.00999	0.24450
0.14250					
119.7890	43.50	139000.0	136397.0	0.00985	0.24310
0.14250					
121.1090	43.56	139000.0	132216.0	0.00974	0.24500
0.13875					
122.5310	43.65	139000.0	132216.0	0.00981	0.24450
0.13875					
123.8010	43.67	139000.0	135003.0	0.00983	0.24390
0.13875					
125.1210	43.98	138000.0	129428.0	0.00987	0.24360
0.13875					
126.5390	44.27	138000.0	126640.0	0.00989	0.24530
0.13500					
127.8090	44.40	138000.0	132216.0	0.00991	0.24630
0.13500					
129.0700	44.62	138000.0	132216.0	0.00993	0.24430

0.13875					
130.3280	44.74	138000.0	136397.0	0.00988	0.24330
0.13875					
131.8200	44.96	138000.0	130822.0	0.00988	0.24450
0.13875					
133.0780	45.05	138000.0	128034.0	0.00987	0.24510
0.12750					
134.3980	45.24	138000.0	132216.0	0.00995	0.24240
0.12750					
135.8280	45.29	138000.0	130822.0	0.00996	0.24060
0.12750					
137.0900	45.29	138000.0	130822.0	0.00994	0.23900
0.12750					
138.3520	45.44	138000.0	128034.0	0.00995	0.24090
0.12750					
139.7810	45.69	138000.0	130822.0	0.00995	0.24310
0.12375					
140.9880	45.93	138000.0	129428.0	0.00994	0.24110
0.13125					
142.3090	46.26	138000.0	129428.0	0.00995	0.24150
0.12750					
143.6290	46.24	138000.0	129428.0	0.01001	0.24200
0.12750					
145.0510	46.44	138000.0	129428.0	0.00994	0.24080
0.12375					
146.3200	46.39	138000.0	130822.0	0.00994	0.24070
0.12750					
147.5310	46.55	138000.0	129428.0	0.00997	0.24000
0.12750					
148.9490	46.64	138000.0	129428.0	0.01004	0.24040
0.12750					
150.1600	46.75	138000.0	129428.0	0.01002	0.24210
0.12750					
151.4800	46.75	138000.0	130822.0	0.01004	0.24170
0.13125					
152.9100	46.97	138000.0	128034.0	0.01009	0.24070
0.12750					
154.2300	46.79	138000.0	128034.0	0.01012	0.24040
0.12750					
155.4880	46.79	138000.0	129428.0	0.01010	0.23960
0.12750					
156.7500	46.81	138000.0	129428.0	0.01009	0.24090
0.12375					
158.2380	46.88	138000.0	129428.0	0.01005	0.24090
0.12375					
159.5510	46.97	138000.0	129428.0	0.01006	0.23960
0.12375					
160.8200	46.99	138000.0	128034.0	0.01004	0.23980
0.12375					
162.2500	47.08	138000.0	132216.0	0.01006	0.24170
0.12375					
163.5120	47.28	138000.0	125246.0	0.01005	0.24240
0.12375					
164.8280	47.32	138000.0	126640.0	0.00999	0.24220
0.12375					
166.2620	47.41	138000.0	126640.0	0.01002	0.24180
0.12375					
167.5700	47.39	137000.0	125246.0	0.01003	0.24270
0.12750					
168.8400	47.48	137000.0	125246.0	0.01007	0.24420
0.12750					
170.1600	47.37	137000.0	130822.0	0.00993	0.24360
0.12750					
171.5310	47.52	137000.0	126640.0	0.00984	0.24250
0.12750					
172.8520	47.59	137000.0	125246.0	0.00986	0.24040

0.12750					
174.1090	47.68	137000.0	126640.0	0.00990	0.24190
0.12750					
175.5390	47.70	137000.0	128034.0	0.00999	0.24000
0.13125					
176.8590	47.74	137000.0	126640.0	0.01001	0.23990
0.12750					
178.0590	47.85	137000.0	128034.0	0.01002	0.23910
0.12375					
179.5510	47.96	137000.0	125246.0	0.01007	0.23860
0.13125					
180.8090	48.10	137000.0	125246.0	0.01009	0.23970
0.13125					
182.0700	48.12	137000.0	126640.0	0.01007	0.24110
0.12750					
183.2810	48.19	137000.0	128034.0	0.01004	0.24140
0.13125					
184.7110	48.28	137000.0	128034.0	0.01006	0.24090
0.13500					
185.9690	48.56	137000.0	126640.0	0.01010	0.23990
0.13875					
187.2380	48.72	138000.0	128034.0	0.01015	0.23960
0.14250					
188.7190	48.92	137000.0	126640.0	0.01017	0.24030
0.13875					
189.9800	49.16	137000.0	126640.0	0.01015	0.24080
0.13875					
191.3010	49.21	137000.0	123852.0	0.01018	0.23980
0.14250					
192.6720	49.34	137000.0	123852.0	0.01016	0.24060
0.14250					
193.9880	49.32	137000.0	126640.0	0.01015	0.23990
0.13875					
195.2620	49.29	137000.0	126640.0	0.01013	0.24170
0.13500					
196.5200	49.23	137000.0	126640.0	0.01010	0.24220
0.13125					
197.8910	49.12	137000.0	125246.0	0.01009	0.24270
0.13125					
199.2110	49.14	137000.0	125246.0	0.01010	0.24240
0.13500					
200.5310	49.09	137000.0	123852.0	0.01003	0.24250
0.13875					
201.9610	49.09	137000.0	126640.0	0.01003	0.24250
0.13875					
203.1720	49.01	137000.0	125246.0	0.01000	0.24200
0.13875					
204.4300	49.10	137000.0	126640.0	0.01003	0.24120
0.14250					
205.8010	49.18	137000.0	123852.0	0.01005	0.24070
0.14250					
207.1210	49.29	137000.0	125246.0	0.01008	0.24010
0.14250					
208.4410	49.41	137000.0	123852.0	0.01013	0.23900
0.14625					
209.6990	49.41	137000.0	125246.0	0.01011	0.23840
0.14625					
211.1800	49.47	137000.0	125246.0	0.01012	0.23910
0.14250					
212.4490	49.41	136000.0	125246.0	0.01009	0.23940
0.13875					
213.7110	49.56	136000.0	123852.0	0.01006	0.24080
0.13500					
215.1410	49.56	136000.0	123852.0	0.01002	0.24140
0.13500					
216.4610	49.61	136000.0	123852.0	0.01007	0.24070

0.14250					
217.7190	49.58	136000.0	122458.0	0.01010	0.23950
0.14250					
219.1990	49.63	137000.0	122458.0	0.01015	0.23710
0.14625					
220.4100	49.80	137000.0	123852.0	0.01018	0.23620
0.15000					
221.7300	49.87	136000.0	123852.0	0.01017	0.23620
0.15000					
223.0510	50.00	136000.0	122458.0	0.01015	0.23620
0.15000					
224.4800	50.18	136000.0	122458.0	0.01016	0.23670
0.14625					
225.7380	50.36	136000.0	123852.0	0.01007	0.23750
0.14250					
227.0590	50.49	136000.0	125246.0	0.01008	0.23720
0.14625					
228.4880	50.76	136000.0	123852.0	0.01013	0.23730
0.14625					
229.8010	50.92	136000.0	122458.0	0.01015	0.23760
0.14250					
231.1210	51.05	137000.0	121065.0	0.01017	0.23690
0.14625					
232.4410	51.14	136000.0	123852.0	0.01018	0.23810
0.15000					
233.9220	51.27	137000.0	123852.0	0.01016	0.23780
0.14625					
235.1910	51.47	136000.0	121065.0	0.01016	0.23860
0.14250					
236.5120	51.63	136000.0	121065.0	0.01013	0.24020
0.15000					
237.9880	51.67	136000.0	121065.0	0.01012	0.23960
0.15000					
239.2500	51.83	136000.0	123852.0	0.01006	0.24010
0.15000					
240.4610	51.94	136000.0	121065.0	0.00998	0.24130
0.14250					
241.8910	52.00	136000.0	121065.0	0.00997	0.24170
0.14250					
243.1480	52.27	136000.0	122458.0	0.00994	0.24160
0.13875					
244.4100	52.38	136000.0	122458.0	0.00996	0.24130
0.13875					
245.7300	52.40	136000.0	122458.0	0.01000	0.23950
0.13500					
247.1600	52.51	135000.0	122458.0	0.00998	0.23870
0.13500					
248.4800	52.71	135000.0	122458.0	0.00994	0.23950
0.13125					
249.8010	52.78	135000.0	119671.0	0.00992	0.24030
0.13125					
251.1720	52.67	135000.0	119671.0	0.00996	0.23890
0.13125					
252.4300	52.78	136000.0	118277.0	0.01002	0.23810
0.13125					
253.7500	52.89	135000.0	121065.0	0.01001	0.23870
0.13125					
255.1800	52.85	135000.0	121065.0	0.01000	0.23770
0.13125					
256.5000	52.94	136000.0	119671.0	0.01007	0.23720
0.12750					
257.7620	53.05	136000.0	118277.0	0.01009	0.23720
0.13500					
259.0200	53.09	135000.0	118277.0	0.01005	0.23810
0.13125					
260.5120	53.25	135000.0	121065.0	0.00999	0.23870

0.13125											
261.7700	53.25	136000.0	119671.0	0.01007	0.23830						
0.13500											
263.0310	53.40	135000.0	119671.0	0.01012	0.23630						
0.13500											
264.4100	53.49	135000.0	121065.0	0.01014	0.23540						
0.13125											
265.7300	53.53	136000.0	119671.0	0.01015	0.23570						
0.14250											
267.0390	53.73	135000.0	118277.0	0.01015	0.23600						
0.14250											
268.4690	53.87	135000.0	119671.0	0.01016	0.23610						
0.14250											
269.6800	54.05	135000.0	116883.0	0.01010	0.23830						
0.14250											
271.0000	54.13	135000.0	119671.0	0.01012	0.23690						
0.14625											
272.3200	54.31	135000.0	119671.0	0.01017	0.23490						
0.14250											
273.7380	54.58	135000.0	118277.0	0.01024	0.23300						
0.14250											
275.0590	54.87	135000.0	118277.0	0.01022	0.23350						
0.14625											
276.3280	55.02	135000.0	119671.0	0.01022	0.23320						
0.14250											
277.7500	55.20	135000.0	118277.0	0.01019	0.23420						
0.13875											
279.0200	55.40	135000.0	118277.0	0.01021	0.23390						
0.13500											
280.3400	55.40	135000.0	118277.0	0.01020	0.23440						
0.13875											
281.8200	55.58	135000.0	121065.0	0.01018	0.23480						
0.13125											
283.0780	55.60	135000.0	119671.0	0.01010	0.23760						
0.13500											
284.3520	55.58	135000.0	119671.0	0.01003	0.23900						
0.13125											
285.6600	55.67	135000.0	118277.0	0.01003	0.24110						
0.13125											
287.0900	55.89	135000.0	118277.0	0.01002	0.24260						
0.13125											
288.3520	55.87	135000.0	116883.0	0.01005	0.24180						
0.12750											
289.6210	56.07	135000.0	116883.0	0.01011	0.24040						
0.12750											
290.9880	56.25	135000.0	118277.0	0.01013	0.23850						
0.13125											
292.3090	56.47	135000.0	118277.0	0.01015	0.23710						
0.13875											
293.6290	56.45	135000.0	115489.0	0.01023	0.23590						
0.13875											
295.0590	56.56	135000.0	118277.0	0.01027	0.23430						
0.14250											
296.2620	56.74	135000.0	116883.0	0.01027	0.23420						
0.14625											
297.5780	56.78	135000.0	116883.0	0.01028	0.23360						
0.14250											
298.8980	56.89	134000.0	116883.0	0.01025	0.23360						
0.13875											
300.3280	56.94	134000.0	116883.0	0.01029	0.23140						
0.13875											
301.5900	56.98	135000.0	118277.0	0.01029	0.23150						
0.13500											
302.9100	57.13	135000.0	118277.0	0.01022	0.23310						
0.13500											
304.3910	57.13	135000.0	119671.0	0.01018	0.23380						

0.13500											
305.6020	57.36	135000.0	118277.0	0.01020	0.23430						
0.13500											
306.9220	57.42	135000.0	116883.0	0.01016	0.23510						
0.13500											
308.3980	57.69	134000.0	118277.0	0.01016	0.23490						
0.13500											
309.7190	57.82	134000.0	115489.0	0.01014	0.23540						
0.13875											
311.0390	57.98	134000.0	116883.0	0.01013	0.23460						
0.13500											
312.3590	58.27	134000.0	116883.0	0.01012	0.23520						
0.13125											
313.8400	58.34	134000.0	118277.0	0.01008	0.23690						
0.13500											
315.2110	58.31	134000.0	115489.0	0.01010	0.23630						
0.13500											
316.5310	58.49	134000.0	115489.0	0.01014	0.23540						
0.13125											
317.8980	58.65	134000.0	115489.0	0.01017	0.23490						
0.13125											
319.1720	58.76	134000.0	115489.0	0.01009	0.23680						
0.13125											
320.4880	58.91	134000.0	118277.0	0.01008	0.23750						
0.13125											
321.9690	59.00	134000.0	116883.0	0.01003	0.23850						
0.13500											
323.2300	59.29	134000.0	118277.0	0.01001	0.23850						
0.13500											
324.4410	59.54	134000.0	118277.0	0.01005	0.23770						
0.13125											
325.6990	59.56	134000.0	115489.0	0.01002	0.23780						
0.13125											
327.0780	59.81	135000.0	114095.0	0.01008	0.23740						
0.13125											
328.3400	59.90	134000.0	115489.0	0.01009	0.23650						
0.13125											
329.6600	60.01	135000.0	116883.0	0.01007	0.23690						
0.12750											
331.0310	60.12	135000.0	116883.0	0.01005	0.23830						
0.12750											
332.3520	60.01	134000.0	116883.0	0.01004	0.23870						
0.13125											
333.6090	60.16	134000.0	118277.0	0.01002	0.23840						
0.12750											
335.0390	60.36	134000.0	116883.0	0.01001	0.23820						
0.12750											
336.3010	60.52	134000.0	115489.0	0.00996	0.23900						
0.12375											
337.6210	60.54	134000.0	114095.0	0.00995	0.23930						
0.12375											
338.8910	60.70	134000.0	116883.0	0.00993	0.23890						
0.12375											
340.3090	60.90	134000.0	116883.0	0.00993	0.23910						
0.12375											
341.5200	61.07	134000.0	115489.0	0.00992	0.23870						
0.12000											
342.8400	61.16	133000.0	116883.0	0.00989	0.23890						
0.12375											
344.2110	61.34	134000.0	114095.0	0.00992	0.23700						
0.12750											
345.5310	61.43	133000.0	115489.0	0.00996	0.23600						
0.12000											
346.8010	61.45	133000.0	115489.0	0.00996	0.23480						
0.12375											
348.0590	61.67	133000.0	115489.0	0.01005	0.23230						

0.12375											
349.4300	61.74	133000.0	114095.0	0.01008	0.23020						
0.12000											
350.6990	61.85	133000.0	112701.0	0.01005	0.23070						
0.12000											
351.8980	61.87	133000.0	115489.0	0.01004	0.23000						
0.12000											
353.3280	62.10	133000.0	112701.0	0.01006	0.22990						
0.12375											
354.6480	62.19	133000.0	115489.0	0.01007	0.22910						
0.12750											
355.9100	62.30	133000.0	116883.0	0.01002	0.22940						
0.12375											
357.3400	62.39	133000.0	116883.0	0.00999	0.23060						
0.12000											
358.6600	62.50	133000.0	115489.0	0.00999	0.23090						
0.11625											
359.9800	62.54	133000.0	112701.0	0.00994	0.23170						
0.12000											
361.2380	62.61	133000.0	114095.0	0.00995	0.23180						
0.12000											
362.6720	62.77	133000.0	114095.0	0.00992	0.23160						
0.12000											
363.9300	62.92	133000.0	114095.0	0.00990	0.23220						
0.12000											
365.2500	63.03	133000.0	114095.0	0.00990	0.23230						
0.12000											
366.6800	63.05	133000.0	114095.0	0.00990	0.23270						
0.12375											
368.0000	63.21	133000.0	112701.0	0.00985	0.23410						
0.13500											
369.3090	63.32	133000.0	114095.0	0.00981	0.23560						
0.13875											
370.7380	63.50	133000.0	114095.0	0.00976	0.23690						
0.13875											
372.0120	63.59	133000.0	112701.0	0.00979	0.23580						
0.13875											
373.2700	63.81	133000.0	115489.0	0.00976	0.23610						
0.13875											
374.5900	63.97	133000.0	112701.0	0.00980	0.23540						
0.14625											
376.0200	64.10	133000.0	116883.0	0.00973	0.23650						
0.14625											
377.2810	64.30	133000.0	115489.0	0.00974	0.23710						
0.14250											
378.6020	64.37	133000.0	115489.0	0.00972	0.23810						
0.13875											
379.9690	64.48	133000.0	114095.0	0.00973	0.23780						
0.14250											
381.2890	64.64	133000.0	112701.0	0.00974	0.23730						
0.13875											
382.6090	64.80	133000.0	114095.0	0.00970	0.23850						
0.14250											
384.0900	64.91	133000.0	115489.0	0.00967	0.23930						
0.13875											
385.3520	64.95	133000.0	114095.0	0.00967	0.23960						
0.13875											
386.6210	65.13	133000.0	115489.0	0.00963	0.24080						
0.13875											
387.8790	65.46	133000.0	115489.0	0.00961	0.24000						
0.13500											
389.3590	65.19	133000.0	116883.0	0.00961	0.23990						
0.13500											
390.6290	65.33	133000.0	115489.0	0.00956	0.24120						
0.13125											
391.9410	65.55	132000.0	115489.0	0.00950	0.24250						

0.13125											
393.4300	65.66	132000.0	114095.0	0.00951	0.24110						
0.13875											
394.6910	65.69	132000.0	114095.0	0.00952	0.23980						
0.13875											
395.9490	65.80	132000.0	114095.0	0.00947	0.24030						
0.13875											
397.4410	65.95	132000.0	114095.0	0.00947	0.23970						
0.14250											
398.6990	65.91	132000.0	112701.0	0.00950	0.23920						
0.15000											
399.9610	66.11	132000.0	111307.0	0.00949	0.23880						
0.14625											
401.2300	66.20	132000.0	112701.0	0.00955	0.23630						
0.13875											
402.6480	66.33	132000.0	114095.0	0.00958	0.23660						
0.13875											
403.9690	66.62	132000.0	111307.0	0.00957	0.23640						
0.14250											
405.2380	66.65	132000.0	114095.0	0.00956	0.23630						
0.14250											
406.6090	66.76	132000.0	115489.0	0.00953	0.23640						
0.14625											
407.9300	66.74	131000.0	115489.0	0.00948	0.23640						
0.15000											
409.2500	66.76	131000.0	114095.0	0.00946	0.23590						
0.14625											
410.6720	66.85	131000.0	112701.0	0.00945	0.23570						
0.14250											
411.9410	66.98	131000.0	111307.0	0.00951	0.23480						
0.14250											
413.1480	67.07	131000.0	114095.0	0.00950	0.23450						
0.13875											
414.4610	67.09	131000.0	111307.0	0.00950	0.23410						
0.13500											
415.9490	67.11	131000.0	114095.0	0.00946	0.23450						
0.13500											
417.2110	67.22	131000.0	114095.0	0.00946	0.23500						
0.13875											
418.4690	67.27	131000.0	114095.0	0.00941	0.23580						
0.13875											
419.9610	67.36	132000.0	115489.0	0.00941	0.23630						
0.13500											
421.3280	67.29	131000.0	112701.0	0.00941	0.23520						
0.14250											
422.6480	67.45	131000.0	111307.0	0.00941	0.23510						
0.13500											
424.0780	67.54	131000.0	114095.0	0.00938	0.23620						
0.13125											
425.3400	67.60	132000.0	114095.0	0.00940	0.23520						
0.13125											
426.5510	67.63	132000.0	114095.0	0.00939	0.23570						
0.13125											
427.8090	67.85	132000.0	114095.0	0.00943	0.23490						
0.13125											
429.1800	67.94	132000.0	114095.0	0.00938	0.23640						
0.13500											
430.5000	68.01	132000.0	116883.0	0.00932	0.23810						
0.13875											
431.7700	68.07	132000.0	114095.0	0.00931	0.23930						
0.13875											
433.3010	68.19	132000.0	115489.0	0.00930	0.23930						
0.13500											
434.6210	68.36	132000.0	114095.0	0.00927	0.24120						
0.13875											
435.8790	68.39	132000.0	114095.0	0.00932	0.24040						

0.14250											
437.2620	68.48	132000.0	111307.0	0.00929	0.24040						
0.13875											
438.5780	68.59	132000.0	114095.0	0.00932	0.23990						
0.13875											
439.8910	68.70	132000.0	111307.0	0.00939	0.23920						
0.13875											
441.1600	68.77	132000.0	114095.0	0.00939	0.23950						
0.13875											
442.5900	68.92	132000.0	114095.0	0.00935	0.24110						
0.13500											
443.7890	68.92	132000.0	111307.0	0.00932	0.24090						
0.13500											
445.0590	68.90	132000.0	114095.0	0.00926	0.24220						
0.14250											
446.4300	69.10	132000.0	111307.0	0.00927	0.24140						
0.13875											
447.7500	69.19	132000.0	112701.0	0.00930	0.24000						
0.13500											
449.0700	69.23	131000.0	114095.0	0.00926	0.24040						
0.13500											
450.5510	69.37	131000.0	112701.0	0.00925	0.24080						
0.13125											
451.8710	69.46	131000.0	111307.0	0.00923	0.24010						
0.13500											
453.1290	69.52	131000.0	111307.0	0.00928	0.23910						
0.13500											
454.3910	69.57	131000.0	114095.0	0.00924	0.23890						
0.13125											
455.7700	69.77	131000.0	109914.0	0.00928	0.23770						
0.13875											
457.0900	69.77	131000.0	111307.0	0.00931	0.23590						
0.13875											
458.3980	69.97	131000.0	109914.0	0.00932	0.23590						
0.13500											
459.8280	70.15	131000.0	112701.0	0.00930	0.23650						
0.13125											
461.1480	70.11	131000.0	112701.0	0.00931	0.23670						
0.13125											
462.4690	70.35	131000.0	114095.0	0.00926	0.23800						
0.12750											
463.7300	70.38	131000.0	114095.0	0.00920	0.23950						
0.12750											
465.1020	70.49	131000.0	112701.0	0.00919	0.24070						
0.13125											
466.4220	70.53	131000.0	111307.0	0.00918	0.24090						
0.13125											
467.7380	70.69	131000.0	109914.0	0.00921	0.24050						
0.12375											
469.1720	70.73	131000.0	111307.0	0.00921	0.23940						
0.12750											
470.4880	70.82	131000.0	114095.0	0.00918	0.23960						
0.12375											
471.8090	70.93	131000.0	114095.0	0.00918	0.23960						
0.12375											
473.1800	71.13	131000.0	111307.0	0.00921	0.23890						
0.12375											
474.4410	71.13	131000.0	112701.0	0.00918	0.23990						
0.12375											
475.7620	71.34	131000.0	114095.0	0.00920	0.23930						
0.12750											
477.0780	71.34	131000.0	111307.0	0.00918	0.24020						
0.12375											
478.5120	71.49	131000.0	111307.0	0.00920	0.23890						
0.12000											
479.8200	71.60	131000.0	111307.0	0.00918	0.24040						

0.12750											
481.1410	71.69	131000.0	111307.0	0.00912	0.24170						
0.12750											
482.5700	71.85	131000.0	114095.0	0.00912	0.24110						
0.12750											
483.8280	71.89	131000.0	109914.0	0.00911	0.24120						
0.13125											
485.1020	71.94	130000.0	112701.0	0.00913	0.23940						
0.13125											
486.5310	72.05	130000.0	109914.0	0.00914	0.23850						
0.12750											
487.7890	72.14	131000.0	112701.0	0.00912	0.23870						
0.12750											
489.1600	72.32	131000.0	112701.0	0.00911	0.23890						
0.12750											
490.4800	72.32	131000.0	111307.0	0.00917	0.23800						
0.12750											
491.8520	72.54	131000.0	109914.0	0.00915	0.23880						
0.12750											
493.1210	72.63	131000.0	112701.0	0.00917	0.23860						
0.12000											
494.4410	72.63	131000.0	111307.0	0.00917	0.23850						
0.12375											
495.8590	72.76	130000.0	114095.0	0.00911	0.23860						
0.12750											
497.1800	72.88	130000.0	111307.0	0.00908	0.23840						
0.13125											
498.3910	73.05	130000.0	112701.0	0.00904	0.23830						
0.13125											
499.8200	73.28	130000.0	108520.0	0.00903	0.23800						
0.12750											
501.1410	73.30	129000.0	112701.0	0.00898	0.23790						
0.12750											
502.4490	73.30	129000.0	109914.0	0.00899	0.23720						
0.12750											
503.7190	73.59	129000.0	111307.0	0.00897	0.23670						
0.12750											
505.0900	73.66	129000.0	111307.0	0.00902	0.23500						
0.12750											
506.3520	73.84	129000.0	109914.0	0.00901	0.23540						
0.12750											
507.6720	73.95	130000.0	109914.0	0.00903	0.23510						
0.12750											
509.0510	73.93	130000.0	108520.0	0.00911	0.23380						
0.12375											
510.3590	74.04	130000.0	112701.0	0.00907	0.23480						
0.12375											
511.6290	74.13	130000.0	109914.0	0.00905	0.23680						
0.12750											
513.0510	74.26	130000.0	111307.0	0.00907	0.23650						
0.13500											
514.2620	74.15	130000.0	111307.0	0.00903	0.23660						
0.13875											
515.5310	74.31	130000.0	112701.0	0.00898	0.23750						
0.14250											
516.7300	74.39	130000.0	111307.0	0.00896	0.23800						
0.13875											
518.2190	74.44	129000.0	111307.0	0.00899	0.23660						
0.13875											
519.5390	74.60	129000.0	109914.0	0.00902	0.23520						
0.14250											
520.8010	74.53	129000.0	109914.0	0.00902	0.23470						
0.14250											
522.1720	74.69	129000.0	111307.0	0.00894	0.23720						
0.14250											
523.4880	74.89	130000.0	111307.0	0.00893	0.23790						

0.15000					
524.8090	75.04	129000.0	109914.0	0.00895	0.23680
0.15000					
526.1800	75.09	129000.0	108520.0	0.00893	0.23660
0.15375					
527.5000	75.25	129000.0	112701.0	0.00886	0.23730
0.15000					
528.7620	75.31	129000.0	111307.0	0.00882	0.23750
0.14250					
530.0780	75.43	129000.0	112701.0	0.00880	0.23820
0.13875					
531.5120	75.47	129000.0	112701.0	0.00874	0.23860
0.14250					
532.7700	75.56	129000.0	111307.0	0.00872	0.23940
0.13875					
534.0390	75.56	129000.0	107126.0	0.00874	0.23990
0.13875					
535.5200	75.65	129000.0	107126.0	0.00878	0.23750
0.14250					
536.7810	75.94	129000.0	111307.0	0.00883	0.23580
0.13875					
538.1020	75.83	129000.0	109914.0	0.00889	0.23360
0.14250					
539.5780	75.83	128000.0	111307.0	0.00887	0.23360
0.13875					
540.8520	76.01	128000.0	111307.0	0.00884	0.23430
0.14250					
542.1720	76.03	128000.0	108520.0	0.00885	0.23380
0.14250					
543.4800	76.12	128000.0	109914.0	0.00884	0.23330
0.14250					
544.8590	76.23	128000.0	108520.0	0.00884	0.23350
0.14250					
546.1210	76.27	128000.0	109914.0	0.00882	0.23320
0.14250					
547.4410	76.30	128000.0	105732.0	0.00881	0.23340
0.14625					
548.8710	76.30	128000.0	109914.0	0.00883	0.23230
0.15000					
550.1800	76.54	128000.0	109914.0	0.00881	0.23210
0.14250					
551.3910	76.50	128000.0	108520.0	0.00884	0.23080
0.15000					
552.8200	76.61	128000.0	109914.0	0.00880	0.23110
0.15000					
554.0780	76.70	128000.0	109914.0	0.00874	0.23240
0.15000					
555.3520	76.85	128000.0	109914.0	0.00869	0.23370
0.14625					
556.6720	77.03	127000.0	109914.0	0.00863	0.23490
0.14250					
558.0900	77.03	127000.0	108520.0	0.00865	0.23400
0.14625					
559.3590	77.26	128000.0	108520.0	0.00867	0.23310
0.14625					
560.6800	77.26	128000.0	107126.0	0.00863	0.23410
0.14250					
562.1020	77.35	128000.0	109914.0	0.00861	0.23340
0.15000					
563.3710	77.39	127000.0	109914.0	0.00864	0.23320
0.14250					
564.6800	77.41	127000.0	108520.0	0.00867	0.23250
0.14625					
566.1720	77.46	127000.0	108520.0	0.00869	0.23170
0.14250					
567.4300	77.53	127000.0	109914.0	0.00864	0.23290

0.13875					
568.6910	77.64	127000.0	109914.0	0.00861	0.23360
0.13500					
570.0120	77.68	127000.0	105732.0	0.00865	0.23260
0.13500					
571.4410	77.70	127000.0	108520.0	0.00862	0.23300
0.13125					
572.6990	77.77	127000.0	107126.0	0.00862	0.23280
0.13125					
574.0200	77.93	127000.0	109914.0	0.00859	0.23340
0.13500					
575.5120	77.90	127000.0	107126.0	0.00854	0.23470
0.13500					
576.7700	78.04	127000.0	109914.0	0.00850	0.23430
0.13500					
577.9800	78.04	127000.0	108520.0	0.00849	0.23510
0.13125					
579.2380	78.17	127000.0	108520.0	0.00847	0.23540
0.13500					
580.6090	78.37	127000.0	108520.0	0.00849	0.23480
0.13125					
581.9300	78.37	127000.0	109914.0	0.00847	0.23430
0.13875					
583.2500	78.57	127000.0	109914.0	0.00844	0.23530
0.13500					
584.6800	78.64	127000.0	111307.0	0.00839	0.23630
0.14250					
586.0000	78.73	127000.0	109914.0	0.00840	0.23570
0.14250					
587.3090	78.82	127000.0	111307.0	0.00837	0.23600
0.13875					
588.7380	79.02	127000.0	108520.0	0.00834	0.23710
0.13500					
589.9490	79.09	127000.0	109914.0	0.00836	0.23730
0.13500					
591.2700	79.29	127000.0	109914.0	0.00834	0.23700
0.13875					
592.5900	79.46	126000.0	109914.0	0.00831	0.23720
0.14250					
594.0200	79.51	126000.0	108520.0	0.00830	0.23790
0.14250					
595.3280	79.67	127000.0	109914.0	0.00825	0.23770
0.14625					
596.6480	79.71	126000.0	109914.0	0.00823	0.23810
0.14625					
598.0780	79.78	126000.0	109914.0	0.00824	0.23730
0.14625					
599.3980	79.87	126000.0	109914.0	0.00823	0.23760
0.14250					
600.6600	80.03	126000.0	108520.0	0.00826	0.23640
0.14625					
602.0900	80.14	126000.0	107126.0	0.00824	0.23780
0.14250					
603.3520	80.14	126000.0	109914.0	0.00818	0.23920
0.14250					
604.6210	80.18	126000.0	109914.0	0.00813	0.24030
0.13500					
605.8200	80.20	126000.0	109914.0	0.00804	0.24210
0.13875					
607.2500	80.36	126000.0	109914.0	0.00800	0.24310
0.13875					
608.5200	80.41	126000.0	109914.0	0.00796	0.24470
0.13875					
609.8280	80.43	126000.0	109914.0	0.00796	0.24510
0.13500					
611.2620	80.50	126000.0	111307.0	0.00788	0.24570

0.13875					
612.5780	80.67	126000.0	108520.0	0.00791	0.24530
0.13125					
613.8980	80.68	126000.0	109914.0	0.00785	0.24590
0.13500					
615.3280	80.72	126000.0	109914.0	0.00781	0.24700
0.13125					
616.6410	80.70	126000.0	109914.0	0.00778	0.24730
0.13125					
617.9610	80.63	126000.0	109914.0	0.00776	0.24680
0.12750					
619.2300	80.74	126000.0	111307.0	0.00771	0.24740
0.13125					
620.6020	80.74	126000.0	111307.0	0.00763	0.24950
0.12750					
621.8590	80.83	126000.0	111307.0	0.00762	0.25010
0.12375					
623.1800	80.83	126000.0	111307.0	0.00756	0.25160
0.12375					
624.6600	80.97	126000.0	111307.0	0.00753	0.25270
0.12375					
625.9800	80.99	126000.0	111307.0	0.00751	0.25310
0.13125					
627.3010	81.10	126000.0	111307.0	0.00747	0.25450
0.12750					
628.6720	81.37	126000.0	112701.0	0.00741	0.25550
0.12750					
630.0510	81.35	126000.0	112701.0	0.00734	0.25680
0.12750					
631.3090	81.48	126000.0	112701.0	0.00727	0.25840
0.12750					
632.5700	81.59	125000.0	111307.0	0.00724	0.25920
0.13125					
634.0000	81.62	126000.0	111307.0	0.00724	0.25940
0.13125					
635.3200	81.62	126000.0	111307.0	0.00724	0.25950
0.12375					
636.5310	81.84	126000.0	112701.0	0.00725	0.25880
0.12000					
638.0120	81.86	125000.0	111307.0	0.00722	0.25980
0.12375					
639.2700	82.08	125000.0	112701.0	0.00720	0.25990
0.12375					
640.5390	82.00	125000.0	112701.0	0.00716	0.26060
0.11625					
641.9100	82.06	125000.0	112701.0	0.00708	0.26210
0.12000					
643.2300	82.04	125000.0	112701.0	0.00705	0.26320
0.12375					
644.5510	82.13	125000.0	112701.0	0.00701	0.26460
0.12750					
645.8090	82.22	125000.0	114095.0	0.00694	0.26590
0.12375					
647.2380	82.29	125000.0	112701.0	0.00687	0.26780
0.12750					
648.5000	82.29	125000.0	112701.0	0.00684	0.26820
0.12375					
649.8200	82.31	125000.0	112701.0	0.00685	0.26810
0.12000					
651.2500	82.42	125000.0	114095.0	0.00676	0.27000
0.12000					
652.5120	82.51	125000.0	114095.0	0.00669	0.27160
0.12000					
653.7700	82.56	125000.0	114095.0	0.00662	0.27280
0.11625					
655.1990	82.62	125000.0	114095.0	0.00656	0.27420

0.11250					
656.5200	82.65	125000.0	114095.0	0.00649	0.27490
0.11625					
657.7810	82.69	125000.0	114095.0	0.00645	0.27560
0.10875					
659.0510	82.82	125000.0	115489.0	0.00637	0.27720
0.11250					
660.5310	82.85	125000.0	115489.0	0.00623	0.28020
0.11250					
661.7890	82.89	124000.0	115489.0	0.00618	0.28220
0.11250					
663.0590	82.98	124000.0	116883.0	0.00612	0.28360
0.11625					
664.4300	82.98	124000.0	115489.0	0.00606	0.28540
0.11250					
665.7500	83.03	124000.0	116883.0	0.00598	0.28710
0.11250					
667.0700	83.23	124000.0	116883.0	0.00593	0.28870
0.11250					
668.4880	83.27	124000.0	116883.0	0.00588	0.29010
0.10875					
669.8090	83.34	124000.0	116883.0	0.00582	0.29090
0.10500					
671.1290	83.54	124000.0	115489.0	0.00576	0.29290
0.10125					
672.3910	83.68	124000.0	116883.0	0.00573	0.29330
0.10500					
673.7700	83.72	124000.0	116883.0	0.00571	0.29250
0.10500					
675.0310	84.03	124000.0	116883.0	0.00567	0.29330
0.10500					
676.3520	84.08	124000.0	116883.0	0.00563	0.29360
0.10500					
677.8280	84.12	124000.0	116883.0	0.00558	0.29470
0.10500					
679.0900	84.19	124000.0	116883.0	0.00554	0.29620
0.10500					
680.3590	84.35	124000.0	116883.0	0.00553	0.29620
0.10500					
681.6800	84.48	124000.0	116883.0	0.00552	0.29620
0.10125					
683.1020	84.50	124000.0	116883.0	0.00547	0.29690
0.09750					
684.4220	84.55	123000.0	118277.0	0.00541	0.29790
0.09750					
685.7380	84.57	123000.0	119671.0	0.00532	0.29990
0.09750					
687.1720	84.73	123000.0	118277.0	0.00524	0.30180
0.09750					
688.4880	84.79	123000.0	118277.0	0.00521	0.30330
0.09375					
689.8090	84.95	123000.0	119671.0	0.00516	0.30350
0.09000					
691.2300	85.06	123000.0	119671.0	0.00510	0.30440
0.09000					
692.5510	85.06	123000.0	119671.0	0.00505	0.30560
0.09000					
693.8090	85.26	123000.0	119671.0	0.00502	0.30570
0.09375					
695.0780	85.40	123000.0	119671.0	0.00497	0.30660
0.09375					
696.5120	85.58	123000.0	119671.0	0.00494	0.30800
0.09375					
697.8200	85.64	123000.0	119671.0	0.00490	0.30900
0.09375					
699.1410	85.78	123000.0	119671.0	0.00489	0.30890

0.09375												
700.5700	86.00	123000.0	119671.0	0.00489	0.30840							
0.09000												
701.8910	86.00	123000.0	119671.0	0.00487	0.30890							
0.08625												
703.1480	86.11	123000.0	119671.0	0.00486	0.30890							
0.08625												
704.5780	86.20	123000.0	119671.0	0.00485	0.30890							
0.08625												
705.8980	86.31	123000.0	119671.0	0.00483	0.30920							
0.09000												
707.2190	86.47	123000.0	119671.0	0.00481	0.30880							
0.08625												
708.4800	86.65	123000.0	119671.0	0.00477	0.31010							
0.08625												
709.9610	86.67	123000.0	121065.0	0.00470	0.31120							
0.08625												
711.2810	86.76	123000.0	121065.0	0.00468	0.31150							
0.09000												
712.5390	86.76	123000.0	121065.0	0.00464	0.31210							
0.08250												
713.9220	86.87	122000.0	121065.0	0.00462	0.31240							
0.08250												
715.1800	86.98	122000.0	119671.0	0.00460	0.31320							
0.08250												
716.5000	87.05	122000.0	119671.0	0.00459	0.31240							
0.08625												
717.9800	87.10	122000.0	121065.0	0.00457	0.31280							
0.08625												
719.2500	87.32	122000.0	121065.0	0.00454	0.31290							
0.07875												
720.5120	87.34	122000.0	121065.0	0.00451	0.31320							
0.08250												
721.8280	87.54	122000.0	121065.0	0.00447	0.31350							
0.08250												
723.2500	87.63	122000.0	121065.0	0.00445	0.31490							
0.08250												
724.5700	87.50	122000.0	121065.0	0.00443	0.31580							
0.07875												
725.8910	87.70	122000.0	121065.0	0.00440	0.31560							
0.07875												
727.3200	87.81	122000.0	121065.0	0.00437	0.31520							
0.08250												
728.5780	87.88	122000.0	121065.0	0.00435	0.31630							
0.07875												
729.8520	88.06	122000.0	121065.0	0.00432	0.31630							
0.07875												
731.3280	88.04	122000.0	121065.0	0.00429	0.31700							
0.07875												
732.5900	87.99	122000.0	121065.0	0.00427	0.31750							
0.07875												
733.9100	88.19	122000.0	121065.0	0.00425	0.31730							
0.07875												
735.2300	88.26	122000.0	121065.0	0.00423	0.31810							
0.07500												
736.6600	88.37	122000.0	121065.0	0.00422	0.31750							
0.07125												
737.9220	88.48	122000.0	121065.0	0.00421	0.31700							
0.07125												
739.1800	88.58	122000.0	121065.0	0.00420	0.31740							
0.07500												
740.6720	88.58	122000.0	121065.0	0.00417	0.31760							
0.07500												
741.9300	88.73	122000.0	121065.0	0.00416	0.31800							
0.07500												
743.2500	88.73	122000.0	121065.0	0.00414	0.31790							

0.07500												
744.7300	88.80	122000.0	121065.0	0.00412	0.31890							
0.07125												
745.9880	88.98	122000.0	121065.0	0.00411	0.31930							
0.06750												
747.2620	88.98	122000.0	121065.0	0.00409	0.31870							
0.07125												
748.5780	89.11	122000.0	121065.0	0.00408	0.31900							
0.06750												
750.0000	89.20	121000.0	121065.0	0.00407	0.31810							
0.06375												
751.3200	89.34	121000.0	119671.0	0.00407	0.31820							
0.06375												
752.6410	89.36	121000.0	119671.0	0.00407	0.31850							
0.06375												
754.0700	89.43	121000.0	119671.0	0.00406	0.31840							
0.06750												
755.3910	89.56	121000.0	119671.0	0.00406	0.31840							
0.06750												
756.6990	89.65	121000.0	119671.0	0.00404	0.31880							
0.06750												
758.1290	89.70	121000.0	119671.0	0.00404	0.31860							
0.06750												
759.4490	89.77	121000.0	119671.0	0.00404	0.31870							
0.06375												
760.7700	89.83	121000.0	119671.0	0.00403	0.31890							
0.06750												
762.0310	89.83	121000.0	119671.0	0.00402	0.31830							
0.06375												
763.4100	89.94	121000.0	119671.0	0.00402	0.31820							
0.06375												
764.7190	89.88	121000.0	119671.0	0.00401	0.31810							
0.06375												
766.0390	89.94	121000.0	119671.0	0.00401	0.31810							
0.06375												
767.4690	90.04	121000.0	119671.0	0.00401	0.31790							
0.06000												
768.7890	90.10	121000.0	119671.0	0.00401	0.31740							
0.06000												
770.1090	90.01	121000.0	119671.0	0.00400	0.31770							
0.06000												
771.5310	90.19	121000.0	119671.0	0.00399	0.31740							
0.05625												
772.8520	90.26	121000.0	119671.0	0.00397	0.31730							
0.05625												
774.1720	90.31	121000.0	119671.0	0.00396	0.31750							
0.05625												
775.4300	90.31	121000.0	119671.0	0.00393	0.31820							
0.05625												
776.9220	90.42	121000.0	119671.0	0.00392	0.31750							
0.06000												
778.1800	90.53	121000.0	119671.0	0.00392	0.31700							
0.05625												
779.5000	90.55	121000.0	119671.0	0.00391	0.31740							
0.05625												
780.8710	90.59	121000.0	119671.0	0.00391	0.31650							
0.05625												
782.1290	90.59	121000.0	119671.0	0.00391	0.31630							
0.05625												
783.3980	90.80	121000.0	119671.0	0.00392	0.31570							
0.05625												
784.8280	90.73	121000.0	119671.0	0.00392	0.31550							
0.05625												
786.1410	90.82	120000.0	119671.0	0.00392	0.31580							
0.05625												
787.4100	90.82	120000.0	119671.0	0.00392	0.31610							



0.05625						
788.6720	90.86	120000.0	119671.0	0.00391	0.31560	
0.05625						
790.1480	90.95	120000.0	119671.0	0.00390	0.31520	
0.05625						
791.4220	90.99	120000.0	119671.0	0.00390	0.31560	
0.05250						
792.7380	90.95	120000.0	119671.0	0.00389	0.31590	
0.05250						
794.1600	90.97	120000.0	119671.0	0.00387	0.31580	
0.05250						
795.4800	91.17	120000.0	119671.0	0.00385	0.31510	
0.05625						
796.7500	91.26	120000.0	119671.0	0.00385	0.31520	
0.05625						
798.0120	91.37	120000.0	119671.0	0.00384	0.31520	
0.05250						
799.4880	91.35	120000.0	119671.0	0.00384	0.31540	
0.05250						
800.7500	91.51	120000.0	119671.0	0.00383	0.31370	
0.04875						
802.0700	91.62	120000.0	119671.0	0.00382	0.31480	
0.04875						
803.4490	91.69	120000.0	119671.0	0.00381	0.31540	
0.04875						
804.7620	91.89	120000.0	119671.0	0.00380	0.31550	
0.04875						
806.0780	92.00	120000.0	119671.0	0.00380	0.31550	
0.04875						
807.4610	92.25	120000.0	119671.0	0.00380	0.31490	
0.04500						
808.7700	92.20	120000.0	119671.0	0.00380	0.31540	
0.04500						
810.0900	92.34	120000.0	119671.0	0.00380	0.31380	
0.04500						
811.3010	92.49	120000.0	119671.0	0.00380	0.31310	
0.04500						
812.7810	92.60	120000.0	119671.0	0.00380	0.31330	
0.04500						
814.1020	92.65	120000.0	119671.0	0.00380	0.31300	
0.04875						
815.3590	92.72	120000.0	119671.0	0.00379	0.31340	
0.04875						
816.7890	92.92	120000.0	118277.0	0.00378	0.31300	
0.04500						
818.0590	92.94	119000.0	118277.0	0.00378	0.31200	
0.04500						
819.3710	93.03	120000.0	118277.0	0.00378	0.31160	
0.04500						
820.8010	93.21	119000.0	118277.0	0.00376	0.31220	
0.04500						
822.1210	93.39	119000.0	118277.0	0.00376	0.31220	
0.04125						
823.4410	93.37	119000.0	118277.0	0.00376	0.31100	
0.04125						
824.6990	93.46	119000.0	118277.0	0.00376	0.31120	
0.04125						
826.1290	93.39	119000.0	118277.0	0.00376	0.31230	
0.04125						
827.3910	93.59	119000.0	118277.0	0.00376	0.31230	
0.04500						
828.7110	93.54	119000.0	118277.0	0.00375	0.31300	
0.04500						
830.1410	93.68	119000.0	118277.0	0.00375	0.31210	
0.04125						
831.4610	93.75	119000.0	118277.0	0.00375	0.31150	

0.04125						
832.7810	93.88	119000.0	118277.0	0.00376	0.31070	
0.04125						
834.1990	93.79	119000.0	118277.0	0.00375	0.31150	
0.04125						
835.4690	93.91	119000.0	118277.0	0.00375	0.31150	
0.04125						
836.7300	94.04	119000.0	118277.0	0.00374	0.31060	
0.04125						
838.0510	94.00	119000.0	118277.0	0.00373	0.31070	
0.04125						
839.4800	94.18	119000.0	118277.0	0.00372	0.31030	
0.04125						
840.7380	94.11	119000.0	118277.0	0.00370	0.31090	
0.04125						
842.0590	94.20	119000.0	118277.0	0.00368	0.31030	
0.04125						
843.4880	94.13	119000.0	118277.0	0.00366	0.31070	
0.04125						
844.8010	94.13	119000.0	118277.0	0.00365	0.31030	
0.03750						
846.0700	94.24	119000.0	118277.0	0.00363	0.31060	
0.03750						
847.5510	94.22	119000.0	118277.0	0.00362	0.31100	
0.03750						
848.8710	94.31	119000.0	118277.0	0.00362	0.31030	
0.03750						
850.1290	94.35	119000.0	118277.0	0.00361	0.31070	
0.04125						
851.4490	94.33	119000.0	118277.0	0.00361	0.31030	
0.03750						
852.8790	94.40	119000.0	118277.0	0.00361	0.31080	
0.03750						
854.1410	94.40	119000.0	118277.0	0.00360	0.31090	
0.03750						
855.4100	94.47	119000.0	118277.0	0.00360	0.31100	
0.03750						
856.7810	94.56	118000.0	118277.0	0.00361	0.31010	
0.03750						
858.0390	94.51	118000.0	118277.0	0.00360	0.30990	
0.03750						
859.3590	94.58	118000.0	118277.0	0.00360	0.30980	
0.03750						
860.8400	94.58	118000.0	118277.0	0.00360	0.30940	
0.03750						
862.1090	94.67	118000.0	118277.0	0.00359	0.30870	
0.03750						
863.4220	94.58	118000.0	118277.0	0.00357	0.30890	
0.03750						
864.6910	94.67	118000.0	118277.0	0.00356	0.30840	
0.03750						
866.1210	94.76	118000.0	118277.0	0.00354	0.30870	
0.03750						
867.4880	94.65	118000.0	118277.0	0.00352	0.30790	
0.03750						
868.7500	94.69	118000.0	118277.0	0.00349	0.30810	
0.03750						
870.1800	94.76	118000.0	118277.0	0.00345	0.30870	
0.03750						
871.3910	94.85	118000.0	118277.0	0.00342	0.30950	
0.03750						
872.7620	94.92	118000.0	119671.0	0.00339	0.31080	
0.03750						
874.1910	94.94	118000.0	119671.0	0.00337	0.31200	
0.03750						
875.4490	94.92	118000.0	119671.0	0.00334	0.31200	

0.03750						
876.7190	95.03	118000.0	119671.0	0.00333	0.31230	
0.03750						
878.0310	95.12	118000.0	119671.0	0.00329	0.31230	
0.03750						
879.4610	95.17	118000.0	119671.0	0.00327	0.31260	
0.03750						
880.7300	95.17	118000.0	119671.0	0.00324	0.31380	
0.03750						
881.9880	95.19	118000.0	119671.0	0.00321	0.31420	
0.03750						
883.4690	95.23	118000.0	119671.0	0.00319	0.31370	
0.03750						
884.7890	95.43	118000.0	119671.0	0.00317	0.31300	
0.03750						
886.0510	95.37	118000.0	119671.0	0.00315	0.31320	
0.03750						
887.4300	95.41	118000.0	119671.0	0.00312	0.31270	
0.03750						
888.7500	95.48	118000.0	119671.0	0.00310	0.31340	
0.03750						
890.0590	95.55	118000.0	119671.0	0.00307	0.31380	
0.03750						
891.4410	95.50	118000.0	119671.0	0.00305	0.31340	
0.03750						
892.8090	95.64	118000.0	119671.0	0.00303	0.31420	
0.03750						
894.1290	95.66	118000.0	119671.0	0.00302	0.31420	
0.03750						
895.4490	95.70	118000.0	119671.0	0.00300	0.31450	
0.03750						
896.9300	95.68	118000.0	119671.0	0.00299	0.31470	
0.03750						
898.1910	95.82	117000.0	119671.0	0.00296	0.31460	
0.03750						
899.5120	95.73	117000.0	119671.0	0.00294	0.31500	
0.03750						
900.9410	95.77	117000.0	119671.0	0.00292	0.31460	
0.03750						
902.2620	95.93	117000.0	119671.0	0.00290	0.31410	
0.03750						
903.4690	95.79	117000.0	119671.0	0.00289	0.31390	
0.03750						
904.7300	96.04	117000.0	119671.0	0.00287	0.31370	
0.03750						
906.1020	95.99	117000.0	119671.0	0.00286	0.31400	
0.03750						
907.4220	95.97	117000.0	119671.0	0.00286	0.31430	
0.03750						
908.7380	96.00	117000.0	119671.0	0.00283	0.31400	
0.03750						
910.1090	96.02	117000.0	119671.0	0.00281	0.31400	
0.03750						
911.3710	96.15	117000.0	119671.0	0.00279	0.31480	
0.03750						
912.7500	96.09	117000.0	119671.0	0.00278	0.31450	
0.03750						
914.0120	95.97	117000.0	119671.0	0.00276	0.31390	
0.03750						
915.4410	96.24	117000.0	119671.0	0.00274	0.31380	
0.03750						
916.7620	96.13	117000.0	118277.0	0.00272	0.31350	
0.03750						
918.0780	96.09	117000.0	118277.0	0.00271	0.31330	
0.03750						
919.5000	96.26	117000.0	118277.0	0.00270	0.31330	

0.03750						
920.8200	96.31	117000.0	118277.0	0.00269	0.31290	
0.03750						
922.1410	96.22	117000.0	118277.0	0.00268	0.31300	
0.03750						
923.6210	96.29	117000.0	118277.0	0.00266	0.31310	
0.03750						
924.9410	96.35	117000.0	118277.0	0.00266	0.31290	
0.03750						

### 3) PI041

Time	Tts	Psg(Pa)	Pts(Pa)	Ws	Winj						
1.4920	30.83	395000.0	408000.0	0.00082	0.00694						
2.7500	30.81	395000.0	408000.0	0.00082	0.00694						
4.0120	29.88	395000.0	408000.0	0.00082	0.00686						
5.2810	30.94	395000.0	408000.0	0.00082	0.00694						
6.6520	30.68	395000.0	408000.0	0.00082	0.00694						
7.9100	30.90	395000.0	408000.0	0.00082	0.00694						
9.1800	31.12	395000.0	408000.0	0.00082	0.00694						
10.5000	31.01	395000.0	315000.0	0.00084	0.05149						
11.6990	31.01	390000.0	151000.0	0.00135	0.24878						
12.9730	30.96	389000.0	98000.0	0.00147	0.28331						
14.2930	31.29	390000.0	83000.0	0.00186	0.29070						
15.6600	31.14	389000.0	81000.0	0.00216	0.22539						
16.8130	31.95	389000.0	82000.0	0.00250	0.18784						
18.0200	31.80	389000.0	82000.0	0.00284	0.17999						
19.3400	32.28	388000.0	82000.0	0.00351	0.24783						
20.5510	32.66	388000.0	82000.0	0.00378	0.29481						
21.7620	32.15	387000.0	82000.0	0.00411	0.33220						
23.1330	32.30	387000.0	82000.0	0.00456	0.31012						
24.3910	32.57	388000.0	82000.0	0.00594	0.28859						
25.5430	32.46	387000.0	82000.0	0.00718	0.25482						
26.6990	32.65	386000.0	82000.0	0.00818	0.21187						
28.0200	32.48	386000.0	81000.0	0.00906	0.17231						
29.1720	32.52	385000.0	82000.0	0.00960	0.16668						
30.3830	33.01	385000.0	83000.0	0.01000	0.15039						
31.6990	32.99	385000.0	83000.0	0.01026	0.13567						
32.8520	33.10	384000.0	84000.0	0.01038	0.10789						
34.0630	34.60	386000.0	84000.0	0.01044	0.15183						
35.3830	33.23	385000.0	84000.0	0.01043	0.11644						
36.5820	32.75	384000.0	84000.0	0.01041	0.12982						
37.7420	33.32	384000.0	84000.0	0.01037	0.14459						
38.9490	33.25	384000.0	84000.0	0.01034	0.11529						
40.2620	33.43	382000.0	84000.0	0.01032	0.12715						
41.4730	33.54	383000.0	84000.0	0.01030	0.17097						
42.6330	33.47	383000.0	84000.0	0.01030	0.17192						
44.0000	33.76	382000.0	84000.0	0.01029	0.15334						
45.2110	33.54	383000.0	84000.0	0.01029	0.21171						
46.3590	34.56	382000.0	84000.0	0.01029	0.17737						
47.5700	34.00	382000.0	84000.0	0.01028	0.17760						
48.8910	33.91	382000.0	84000.0	0.01027	0.18026						
50.1020	34.11	381000.0	84000.0	0.01026	0.16272						
51.2500	34.03	381000.0	84000.0	0.01025	0.12846						
52.5700	34.25	380000.0	84000.0	0.01026	0.11974						
53.8320	34.16	382000.0	84000.0	0.01026	0.10617						
54.9800	34.25	381000.0	84000.0	0.01025	0.10480						
56.3010	34.16	380000.0	84000.0	0.01024	0.13253						
57.4610	34.62	380000.0	84000.0	0.01025	0.10837						
58.6090	34.58	380000.0	84000.0	0.01025	0.09919						
59.8200	34.71	379000.0	84000.0	0.01025	0.07938						
61.1410	34.82	379000.0	84000.0	0.01025	0.05851						
62.3520	34.62	379000.0	84000.0	0.01025	0.04529						
63.5000	34.87	379000.0	84000.0	0.01025	0.03847						
64.8200	35.00	379000.0	84000.0	0.01025	0.04319						
65.9730	35.07	378000.0	84000.0	0.01024	0.04598						
67.2300	34.89	378000.0	84000.0	0.01024	0.07890						
68.5510	35.18	378000.0	84000.0	0.01024	0.13509						
69.7620	35.33	377000.0	84000.0	0.01024	0.14756						
70.9100	35.09	377000.0	84000.0	0.01024	0.13434						
72.1800	35.13	377000.0	84000.0	0.01024	0.12504						
73.4410	35.42	377000.0	84000.0	0.01024	0.12020						
74.6520	35.40	376000.0	84000.0	0.01025	0.13083						
75.8010	34.98	376000.0	84000.0	0.01026	0.13792						
77.1720	35.44	375000.0	84000.0	0.01026	0.14434						
78.3320	35.22	376000.0	84000.0	0.01025	0.15597						
79.5430	35.53	376000.0	84000.0	0.01025	0.17569						
80.6910	35.42	375000.0	84000.0	0.01026	0.18748						
81.9490	35.48	375000.0	84000.0	0.01026	0.19270						
83.1600	35.51	374000.0	84000.0	0.01026	0.18355						
84.3200	36.02	375000.0	84000.0	0.01027	0.19782						
85.6330	35.77	374000.0	84000.0	0.01027	0.19159						
86.7930	36.28	374000.0	84000.0	0.01027	0.21334						
88.0000	36.17	374000.0	84000.0	0.01027	0.21525						
89.3130	36.15	374000.0	84000.0	0.01028	0.19719						
90.5200	34.89	374000.0	84000.0	0.01028	0.21246						
91.7300	35.91	374000.0	84000.0	0.01029	0.24915						
92.9410	36.39	373000.0	84000.0	0.01029	0.28049						
94.3130	36.44	373000.0	84000.0	0.01030	0.29058						
95.5200	36.17	373000.0	84000.0	0.01030	0.26237						
96.6720	36.42	373000.0	84000.0	0.01031	0.23556						
97.9920	36.59	372000.0	84000.0	0.01031	0.20585						
99.1990	36.35	372000.0	84000.0	0.01032	0.20734						
100.3010	36.13	371000.0	84000.0	0.01032	0.23284						
101.6720	36.64	371000.0	84000.0	0.01032	0.29258						
102.8830	36.90	371000.0	84000.0	0.01033	0.28678						
104.0900	36.81	371000.0	85000.0	0.01033	0.26805						
105.3010	36.81	371000.0	84000.0	0.01034	0.24311						
106.6090	37.03	370000.0	84000.0	0.01036	0.22539						
107.8200	36.70	370000.0	84000.0	0.01036	0.21872						
109.0310	38.94	370000.0	84000.0	0.01038	0.20894						
110.2930	36.94	370000.0	84000.0	0.01038	0.23198						
111.5000	34.61	370000.0	84000.0	0.01038	0.21606						
112.6020	37.06	370000.0	84000.0	0.01039	0.24122						
113.9730	37.32	370000.0	84000.0	0.01039	0.25959						
115.1800	37.14	369000.0	84000.0	0.01040	0.25901						
116.3910	37.28	369000.0	84000.0	0.01041	0.26815						
117.5510	37.12	368000.0	84000.0	0.01042	0.25741						
118.8590	37.54	368000.0	84000.0	0.01043	0.26049						
120.0200	37.21	368000.0	84000.0	0.01044	0.26757						
121.2300	37.90	368000.0	84000.0	0.01044	0.30353						
122.5430	37.63	368000.0	84000.0	0.01045	0.33691						
123.7500	37.41	367000.0	84000.0	0.01045	0.37312						
124.9100	37.70	367000.0	84000.0	0.01045	0.35563						
126.1090	37.54	367000.0	84000.0	0.01046	0.33823						
127.4300	37.70	367000.0	84000.0	0.01047	0.34698						
128.6410	37.59	367000.0	84000.0	0.01048	0.36658						
129.7930	37.50	366000.0	84000.0	0.01049	0.38809						
131.1090	37.76	366000.0	84000.0	0.01050	0.41679						
132.2700	37.72	366000.0	84000.0	0.01051	0.41842						
133.5310	37.94	366000.0	84000.0	0.01051	0.40481						
134.8520	38.14	366000.0	84000.0	0.01053	0.40801						
136.0630	38.14	365000.0	84000.0	0.01054	0.37713						
137.2620	38.12	365000.0	84000.0	0.01055	0.34329						
138.5310	72.47	365000.0	84000.0	0.01055	0.31988						
139.9020	38.60	365000.0	84000.0	0.01056	0.30511						
141.1090	38.05	364000.0	85000.0	0.01057	0.28850						
142.3710	38.36	364000.0	84000.0	0.01058	0.31274						
143.8010	38.58	364000.0	84000.0	0.01059	0.32069						
145.0120	38.43	363000.0	84000.0	0.01059	0.31959						
146.2700	38.47	363000.0	84000.0	0.01060	0.31414						
147.6410	38.76	363000.0	84000.0	0.01061	0.30159						
148.8520	38.80	363000.0	84000.0	0.01062	0.29540						
150.0120	38.71	363000.0	85000.0	0.01063	0.29943						
151.2110	39.02	363000.0	85000.0	0.01064	0.						

160.0000	39.20	361000.0	84000.0	0.01069	0.27050	242.0120	42.76	347000.0	84000.0	0.01111	0.37449
161.3830	39.31	361000.0	84000.0	0.01070	0.30385	243.1600	43.14	346000.0	84000.0	0.01111	0.37753
162.5820	39.31	360000.0	84000.0	0.01071	0.30525	244.5310	42.94	346000.0	83000.0	0.01111	0.37780
163.8520	40.99	360000.0	84000.0	0.01072	0.31233	245.7420	42.92	346000.0	84000.0	0.01110	0.37510
165.2230	39.36	360000.0	84000.0	0.01072	0.28914	246.8910	43.01	345000.0	84000.0	0.01111	0.36420
166.4800	39.42	360000.0	85000.0	0.01073	0.29950	248.2110	42.99	345000.0	84000.0	0.01111	0.35777
167.6910	39.60	360000.0	84000.0	0.01074	0.29238	249.4220	43.05	346000.0	84000.0	0.01111	0.35748
169.0700	39.69	360000.0	84000.0	0.01075	0.28863	250.5700	43.16	345000.0	84000.0	0.01112	0.36136
170.2700	39.80	359000.0	84000.0	0.01076	0.32104	251.7810	42.87	344000.0	84000.0	0.01112	0.35311
171.4300	39.78	359000.0	84000.0	0.01077	0.34570	253.1020	43.14	344000.0	84000.0	0.01112	0.36862
172.6910	39.73	358000.0	84000.0	0.01078	0.34302	254.3130	43.32	344000.0	84000.0	0.01114	0.36146
173.9490	39.71	358000.0	84000.0	0.01078	0.32683	255.4610	43.29	344000.0	84000.0	0.01114	0.36643
175.1600	40.06	358000.0	84000.0	0.01079	0.33666	256.8400	43.76	344000.0	84000.0	0.01114	0.37325
176.3710	40.00	358000.0	84000.0	0.01081	0.33860	257.9920	43.54	343000.0	83000.0	0.01114	0.38480
177.7420	39.96	358000.0	84000.0	0.01081	0.33556	259.1410	43.23	343000.0	84000.0	0.01115	0.36305
178.9020	40.18	357000.0	85000.0	0.01082	0.34029	260.5200	43.60	343000.0	84000.0	0.01115	0.33230
180.1090	40.26	357000.0	84000.0	0.01083	0.35871	261.7230	43.45	343000.0	84000.0	0.01115	0.31582
181.4220	40.17	357000.0	84000.0	0.01083	0.37441	262.9920	44.80	343000.0	83000.0	0.01116	0.31153
182.6330	40.44	357000.0	84000.0	0.01085	0.37209	264.1990	43.63	342000.0	83000.0	0.01116	0.31656
183.7930	40.11	357000.0	84000.0	0.01086	0.36717	265.6210	43.56	342000.0	84000.0	0.01117	0.27509
184.9920	40.29	357000.0	84000.0	0.01087	0.34493	266.7810	44.18	342000.0	84000.0	0.01118	0.27725
186.3130	40.71	356000.0	84000.0	0.01088	0.34357	267.9920	43.74	343000.0	83000.0	0.01119	0.26161
187.5200	40.55	356000.0	84000.0	0.01089	0.33939	269.3010	43.87	342000.0	84000.0	0.01117	0.25878
188.6720	40.49	356000.0	84000.0	0.01089	0.32729	270.4610	44.07	342000.0	83000.0	0.01118	0.25630
190.0510	40.53	356000.0	84000.0	0.01091	0.28303	271.6720	43.87	342000.0	84000.0	0.01119	0.27308
191.2620	41.06	356000.0	84000.0	0.01091	0.29639	273.0430	44.07	341000.0	84000.0	0.01119	0.27495
192.4610	40.77	355000.0	84000.0	0.01092	0.32344	274.2500	44.42	341000.0	84000.0	0.01119	0.29231
193.7810	40.73	355000.0	83000.0	0.01093	0.34514	275.4610	44.00	341000.0	83000.0	0.01119	0.30412
194.9410	40.97	355000.0	84000.0	0.01094	0.34678	276.6600	42.98	342000.0	83000.0	0.01119	0.29195
196.1410	40.99	354000.0	84000.0	0.01094	0.34731	278.0430	44.27	341000.0	83000.0	0.01118	0.27446
197.3010	40.68	355000.0	84000.0	0.01095	0.33959	279.1910	44.49	341000.0	84000.0	0.01119	0.24941
198.6720	41.30	354000.0	84000.0	0.01095	0.31201	280.4020	44.49	340000.0	84000.0	0.01119	0.23924
199.8830	41.06	354000.0	84000.0	0.01096	0.32165	281.7230	44.56	340000.0	84000.0	0.01120	0.24807
201.0900	41.08	354000.0	84000.0	0.01097	0.33413	282.9800	44.38	340000.0	84000.0	0.01120	0.26444
202.4100	41.10	353000.0	84000.0	0.01098	0.33882	284.1910	44.71	340000.0	83000.0	0.01120	0.27082
203.6090	41.15	354000.0	84000.0	0.01099	0.35238	285.4490	44.51	339000.0	83000.0	0.01121	0.26935
204.7700	41.06	353000.0	84000.0	0.01099	0.36307	286.8320	44.89	339000.0	84000.0	0.01121	0.26472
205.9800	40.97	353000.0	84000.0	0.01100	0.33598	288.0900	44.64	339000.0	84000.0	0.01121	0.26331
207.3520	41.26	353000.0	84000.0	0.01101	0.31770	289.2420	44.69	338000.0	83000.0	0.01121	0.25583
208.5630	41.57	352000.0	84000.0	0.01101	0.30897	290.5630	44.64	338000.0	83000.0	0.01122	0.24932
209.7700	41.39	352000.0	84000.0	0.01101	0.30622	291.7110	44.73	338000.0	83000.0	0.01122	0.23307
211.1910	41.37	352000.0	85000.0	0.01101	0.31901	292.8710	57.17	338000.0	84000.0	0.01122	0.23537
212.3520	41.30	352000.0	84000.0	0.01101	0.33865	294.1910	44.98	337000.0	84000.0	0.01123	0.23970
213.5510	41.48	351000.0	84000.0	0.01102	0.35466	295.3400	44.69	338000.0	84000.0	0.01123	0.24803
214.8710	41.39	351000.0	84000.0	0.01103	0.35166	296.5510	45.00	338000.0	85000.0	0.01123	0.21948
216.0820	41.86	351000.0	85000.0	0.01103	0.34492	297.6990	44.80	338000.0	84000.0	0.01124	0.21463
217.2930	41.88	351000.0	84000.0	0.01103	0.32341	299.0200	45.26	337000.0	84000.0	0.01122	0.21549
218.4410	41.81	351000.0	84000.0	0.01104	0.32659	299.0200	45.26	337000.0	84000.0	0.01122	0.21549
219.8200	41.90	350000.0	84000.0	0.01104	0.32577	300.2300	45.06	337000.0	85000.0	0.01122	0.23256
221.0200	41.66	350000.0	84000.0	0.01104	0.34045	301.4410	45.13	337000.0	83000.0	0.01123	0.22757
222.2300	42.14	349000.0	84000.0	0.01104	0.34025	302.7500	45.42	337000.0	84000.0	0.01124	0.21775
223.6600	41.88	350000.0	84000.0	0.01105	0.31998	303.9610	45.11	336000.0	85000.0	0.01124	0.20479
224.8710	41.92	349000.0	84000.0	0.01106	0.31639	305.1720	44.51	336000.0	84000.0	0.01125	0.21604
226.1330	42.17	349000.0	84000.0	0.01106	0.31830	306.4920	45.31	337000.0	83000.0	0.01126	0.22499
227.5120	42.25	350000.0	83000.0	0.01106	0.32060	307.6410	45.40	335000.0	84000.0	0.01126	0.23037
228.6600	42.19	349000.0	84000.0	0.01106	0.33389	308.8520	45.66	336000.0	83000.0	0.01126	0.24705
229.8130	42.50	349000.0	84000.0	0.01106	0.33812	310.0000	45.81	335000.0	84000.0	0.01125	0.23215
231.0200	42.45	348000.0	84000.0	0.01106	0.33751	311.3830	47.61	335000.0	83000.0	0.01127	0.21446
232.3400	42.37	348000.0	84000.0	0.01107	0.34120	312.5310	45.57	335000.0	84000.0	0.01127	0.19723
233.5510	42.61	347000.0	84000.0	0.01107	0.33796	313.7420	45.82	335000.0	84000.0	0.01127	0.19569
234.6990	42.74	347000.0	84000.0	0.01107	0.34132	315.0630	45.88	335000.0	84000.0	0.01126	0.19640
236.0200	42.43	347000.0	83000.0	0.01107	0.34781	316.2700	45.79	334000.0	84000.0	0.01127	0.20088
237.1720	42.48	347000.0	83000.0	0.01109	0.35062	317.4220	45.97	335000.0	84000.0	0.01127	0.21321
238.3830	42.76	347000.0	83000.0	0.01109	0.35843	318.6330	46.10	334000.0	84000.0	0.01127	0.20951
239.5310	42.85	347000.0	83000.0	0.01110	0.36678	319.9490	49.78	334000.0	84000.0	0.01128	0.22270
240.8520	42.79	347000.0	83000.0	0.01110	0.37897	321.1020	45.81	333000.0	84000.0	0.01128	0.22218
						322.3130	46.17	333000.0	84000.0	0.01128	0.23235



323.6330	46.15	333000.0	84000.0	0.01129	0.25123	404.4220	49.22	321000.0	85000.0	0.01141	0.20262
324.8320	46.06	333000.0	84000.0	0.01129	0.23498	405.7930	49.18	321000.0	83000.0	0.01141	0.21221
325.9920	33.49	333000.0	83000.0	0.01129	0.22703	406.9490	49.38	321000.0	84000.0	0.01141	0.22364
327.3590	46.06	333000.0	84000.0	0.01130	0.23545	408.1600	49.27	320000.0	84000.0	0.01141	0.20621
328.5120	36.93	333000.0	84000.0	0.01130	0.23475	409.3130	49.53	320000.0	84000.0	0.01141	0.21612
329.6720	46.46	332000.0	84000.0	0.01130	0.23355	410.6330	49.26	320000.0	84000.0	0.01142	0.23455
330.8830	46.37	332000.0	84000.0	0.01131	0.23836	411.8400	49.40	320000.0	84000.0	0.01142	0.22280
332.1910	46.43	332000.0	84000.0	0.01130	0.23653	413.0430	49.71	320000.0	84000.0	0.01142	0.21995
333.4020	46.74	332000.0	84000.0	0.01131	0.23005	414.3130	49.69	320000.0	84000.0	0.01143	0.20524
334.5630	46.48	332000.0	84000.0	0.01130	0.23096	415.5200	49.64	320000.0	84000.0	0.01143	0.19124
335.9300	46.44	332000.0	84000.0	0.01130	0.22091	416.7230	49.49	319000.0	85000.0	0.01144	0.17852
337.0820	46.46	331000.0	84000.0	0.01131	0.21442	418.0430	50.18	319000.0	84000.0	0.01144	0.16359
338.2930	46.70	331000.0	84000.0	0.01132	0.21505	419.2500	51.47	319000.0	84000.0	0.01143	0.17239
339.6090	50.58	331000.0	84000.0	0.01132	0.22019	420.4020	46.84	319000.0	84000.0	0.01144	0.19677
340.8200	47.01	331000.0	84000.0	0.01131	0.23207	421.6090	50.07	319000.0	84000.0	0.01144	0.20727
341.9730	47.72	331000.0	84000.0	0.01133	0.25164	422.9300	50.06	318000.0	84000.0	0.01143	0.18240
343.2300	46.81	330000.0	84000.0	0.01133	0.27620	424.1410	50.00	319000.0	84000.0	0.01144	0.20380
344.5510	46.10	330000.0	84000.0	0.01133	0.25200	425.2930	49.75	318000.0	84000.0	0.01144	0.19387
345.7110	46.95	329000.0	84000.0	0.01132	0.22919	426.6720	50.20	318000.0	84000.0	0.01145	0.18305
346.8590	47.12	329000.0	84000.0	0.01132	0.22256	427.8200	50.20	318000.0	84000.0	0.01145	0.18388
348.2300	46.75	329000.0	84000.0	0.01133	0.21861	429.0310	50.00	317000.0	84000.0	0.01144	0.18967
349.3910	47.10	329000.0	84000.0	0.01133	0.22964	430.3520	50.09	318000.0	84000.0	0.01144	0.19913
350.5430	47.19	329000.0	84000.0	0.01133	0.24052	431.5510	50.15	317000.0	84000.0	0.01144	0.21441
351.9100	46.32	329000.0	84000.0	0.01133	0.24324	432.7110	50.06	317000.0	84000.0	0.01145	0.21084
353.0700	47.17	329000.0	84000.0	0.01133	0.24284	433.8590	50.33	316000.0	84000.0	0.01145	0.18763
354.2700	47.45	329000.0	84000.0	0.01134	0.23841	435.2300	50.40	316000.0	84000.0	0.01146	0.17911
355.4300	47.28	328000.0	83000.0	0.01133	0.21077	436.3910	50.64	316000.0	84000.0	0.01146	0.16909
356.8010	47.56	328000.0	84000.0	0.01134	0.17319	437.6020	50.73	315000.0	84000.0	0.01146	0.14936
357.9490	47.54	328000.0	84000.0	0.01134	0.15930	438.9100	50.68	316000.0	84000.0	0.01147	0.13041
359.1600	47.67	327000.0	84000.0	0.01135	0.13844	440.1210	50.51	316000.0	84000.0	0.01147	0.12768
360.4800	47.81	328000.0	83000.0	0.01135	0.12444	441.2810	46.49	315000.0	84000.0	0.01147	0.12157
361.6330	47.65	328000.0	84000.0	0.01135	0.12765	442.4800	50.80	316000.0	84000.0	0.01148	0.12605
362.8400	47.47	328000.0	84000.0	0.01135	0.12043	443.8010	50.82	315000.0	84000.0	0.01147	0.13716
364.0510	47.54	327000.0	84000.0	0.01136	0.11581	445.0120	50.88	315000.0	84000.0	0.01147	0.13229
365.3130	48.01	326000.0	84000.0	0.01136	0.11845	446.1600	50.93	314000.0	84000.0	0.01148	0.13489
366.5200	47.54	327000.0	84000.0	0.01137	0.13412	447.4800	51.06	315000.0	84000.0	0.01147	0.17144
367.6800	47.76	326000.0	84000.0	0.01136	0.13227	448.6410	50.84	316000.0	84000.0	0.01148	0.18619
369.0510	47.98	327000.0	84000.0	0.01137	0.16169	449.8400	51.20	314000.0	84000.0	0.01149	0.16771
370.1990	47.94	326000.0	84000.0	0.01137	0.17610	451.1600	51.15	314000.0	84000.0	0.01149	0.16153
371.3590	47.83	326000.0	83000.0	0.01137	0.17964	452.3710	51.37	314000.0	84000.0	0.01148	0.14485
372.7300	48.12	326000.0	84000.0	0.01137	0.18212	453.5200	51.11	313000.0	84000.0	0.01148	0.13027
373.8830	48.12	326000.0	84000.0	0.01137	0.20557	454.7300	51.17	314000.0	84000.0	0.01148	0.11447
375.0430	47.83	325000.0	84000.0	0.01136	0.21868	456.0510	51.28	313000.0	84000.0	0.01147	0.12286
376.2420	48.38	325000.0	84000.0	0.01137	0.23150	457.1990	51.48	312000.0	84000.0	0.01148	0.10569
377.6210	48.29	325000.0	84000.0	0.01137	0.23428	458.4100	51.22	313000.0	84000.0	0.01147	0.09286
378.7700	48.34	324000.0	84000.0	0.01138	0.24162	459.7300	51.37	312000.0	84000.0	0.01148	0.10422
379.9220	71.73	325000.0	84000.0	0.01138	0.24324	460.9410	51.30	312000.0	84000.0	0.01148	0.12436
381.3010	48.54	324000.0	84000.0	0.01138	0.23744	462.0900	51.28	311000.0	84000.0	0.01149	0.16838
382.4490	48.25	324000.0	84000.0	0.01138	0.22290	463.4730	51.55	311000.0	84000.0	0.01149	0.15753
383.6600	48.45	324000.0	84000.0	0.01138	0.22081	464.6210	51.55	311000.0	84000.0	0.01149	0.15370
384.9800	48.82	324000.0	84000.0	0.01138	0.21264	465.8320	51.43	311000.0	84000.0	0.01149	0.15271
386.1910	48.31	323000.0	84000.0	0.01138	0.22311	466.9800	51.68	311000.0	84000.0	0.01149	0.16195
387.3400	48.56	323000.0	84000.0	0.01139	0.20559	468.3010	51.68	311000.0	84000.0	0.01149	0.15090
388.4920	48.34	324000.0	84000.0	0.01140	0.19328	469.5120	51.92	311000.0	84000.0	0.01149	0.16818
389.8130	48.69	323000.0	84000.0	0.01140	0.17430	470.6600	51.68	311000.0	84000.0	0.01149	0.16019
390.9610	48.89	323000.0	84000.0	0.01140	0.16985	471.9800	51.77	311000.0	85000.0	0.01149	0.15344
392.1720	48.78	323000.0	84000.0	0.01140	0.17663	473.1330	51.72	311000.0	84000.0	0.01149	0.16431
393.4920	46.52	323000.0	84000.0	0.01141	0.18386	474.3400	51.70	310000.0	84000.0	0.01150	0.15745
394.6990	49.02	323000.0	84000.0	0.01141	0.20672	475.4920	51.97	310000.0	84000.0	0.01150	0.14003
395.8520	53.58	323000.0	84000.0	0.01141	0.23038	476.8710	51.99	310000.0	84000.0	0.01150	0.12763
397.0630	48.78	323000.0	84000.0	0.01141	0.21252	478.0200	51.75	310000.0	84000.0	0.01151	0.14948
398.3830	48.80	321000.0	84000.0	0.01141	0.20616	479.2300	51.46	310000.0	84000.0	0.01150	0.15006
399.5310	49.00	321000.0	84000.0	0.01141	0.20305	480.5510	50.93	309000.0	84000.0	0.01150	0.15207
400.7420	48.98	322000.0	84000.0	0.01140	0.20482	481.7620	57.87	309000.0	84000.0	0.01150	0.14684
402.0630	49.00	321000.0	84000.0	0.01141	0.21082	482.9100	52.15	309000.0	84000.0	0.01151	0.14347
403.2700	49.73	321000.0	84000.0	0.01140	0.20205	484.2810	51.44	310000.0	84000.0	0.01151	0.11693

485.4410	53.45	309000.0	84000.0	0.01151	0.11510	566.3400	53.85	298000.0	84000.0	0.01164	0.09647
486.6410	53.99	308000.0	84000.0	0.01151	0.12409	567.7110	51.02	297000.0	84000.0	0.01164	0.09467
487.8010	50.31	308000.0	84000.0	0.01151	0.11787	568.8710	53.74	298000.0	84000.0	0.01164	0.10450
489.1210	51.61	308000.0	84000.0	0.01151	0.10056	570.1330	55.90	297000.0	84000.0	0.01163	0.09594
490.3200	50.46	308000.0	84000.0	0.01152	0.09265	571.4490	54.25	297000.0	84000.0	0.01163	0.08690
491.4800	51.02	308000.0	84000.0	0.01152	0.09504	572.6600	54.18	297000.0	84000.0	0.01162	0.08387
492.8520	53.78	307000.0	84000.0	0.01152	0.09877	573.8130	56.54	297000.0	84000.0	0.01163	0.08695
494.0000	51.99	308000.0	84000.0	0.01151	0.10058	575.1330	56.08	296000.0	84000.0	0.01164	0.08130
495.2110	53.58	308000.0	84000.0	0.01152	0.09136	576.2810	55.39	296000.0	84000.0	0.01164	0.08639
496.5310	54.10	307000.0	84000.0	0.01152	0.08493	577.4920	55.03	296000.0	84000.0	0.01164	0.09040
497.7420	54.12	307000.0	84000.0	0.01153	0.08651	578.6410	54.83	296000.0	84000.0	0.01164	0.08690
498.8910	51.70	307000.0	84000.0	0.01154	0.09619	580.0200	54.81	296000.0	84000.0	0.01164	0.09346
500.1020	51.77	307000.0	84000.0	0.01154	0.09349	581.1720	56.41	296000.0	84000.0	0.01166	0.09454
501.4220	51.24	306000.0	84000.0	0.01153	0.09425	582.3830	54.54	294000.0	84000.0	0.01164	0.08440
502.5700	53.10	307000.0	84000.0	0.01154	0.10884	583.6990	54.63	295000.0	84000.0	0.01164	0.07577
503.7810	53.90	305000.0	84000.0	0.01154	0.09938	584.9100	56.21	295000.0	84000.0	0.01164	0.07442
505.1020	53.81	306000.0	84000.0	0.01154	0.08709	586.0630	54.65	295000.0	84000.0	0.01165	0.07704
506.3130	54.43	306000.0	84000.0	0.01153	0.08513	587.3830	55.18	295000.0	84000.0	0.01164	0.08446
507.4610	53.43	305000.0	84000.0	0.01153	0.08330	588.5310	54.87	294000.0	84000.0	0.01164	0.08469
508.8320	52.57	305000.0	84000.0	0.01153	0.08357	589.6800	56.48	295000.0	84000.0	0.01164	0.09311
509.9920	51.11	305000.0	84000.0	0.01154	0.08742	590.8910	55.83	295000.0	84000.0	0.01164	0.11513
511.1990	52.61	305000.0	84000.0	0.01155	0.07737	592.1600	56.17	294000.0	84000.0	0.01164	0.11474
512.3520	53.72	305000.0	84000.0	0.01155	0.06650	593.3590	55.12	294000.0	84000.0	0.01164	0.10461
513.7230	54.43	305000.0	84000.0	0.01155	0.07104	594.5200	58.37	294000.0	84000.0	0.01164	0.09924
514.9300	54.30	305000.0	84000.0	0.01156	0.08046	595.8910	56.90	293000.0	84000.0	0.01165	0.10186
516.1910	54.48	304000.0	84000.0	0.01155	0.08819	597.0430	57.39	294000.0	84000.0	0.01165	0.09303
517.5120	52.21	304000.0	84000.0	0.01155	0.09178	598.2500	56.30	293000.0	84000.0	0.01165	0.08868
518.6720	59.02	304000.0	84000.0	0.01155	0.08821	599.4100	56.46	293000.0	84000.0	0.01165	0.09258
519.8710	54.00	304000.0	84000.0	0.01156	0.09524	600.7230	56.90	293000.0	84000.0	0.01165	0.08488
521.0310	52.32	304000.0	84000.0	0.01155	0.11130	601.9300	55.43	293000.0	84000.0	0.01166	0.07601
522.3520	53.05	303000.0	84000.0	0.01155	0.12892	603.1410	55.12	293000.0	84000.0	0.01166	0.06901
523.5000	54.83	302000.0	84000.0	0.01155	0.10844	604.4610	55.83	293000.0	84000.0	0.01165	0.06829
524.7110	52.04	303000.0	84000.0	0.01155	0.11591	605.6720	56.26	292000.0	84000.0	0.01166	0.07548
526.0310	52.90	303000.0	84000.0	0.01156	0.12078	606.8200	56.95	292000.0	84000.0	0.01166	0.07567
527.2300	52.61	303000.0	84000.0	0.01156	0.11425	608.1450	56.28	292000.0	84000.0	0.01166	0.06984
528.3910	55.14	303000.0	84000.0	0.01157	0.10655	609.3480	54.37	292000.0	84000.0	0.01166	0.06861
529.7620	52.17	303000.0	84000.0	0.01157	0.09604	610.5590	57.23	292000.0	84000.0	0.01166	0.06878
530.9730	52.85	302000.0	84000.0	0.01157	0.10162	611.7150	58.08	292000.0	84000.0	0.01166	0.07264
532.1210	53.05	302000.0	84000.0	0.01157	0.11600	613.0270	56.72	291000.0	84000.0	0.01167	0.06529
533.3320	54.54	303000.0	84000.0	0.01157	0.12863	614.2380	55.72	291000.0	84000.0	0.01167	0.06381
534.6520	54.83	302000.0	84000.0	0.01157	0.13938	615.3950	57.01	291000.0	84000.0	0.01167	0.07291
535.8590	58.62	302000.0	84000.0	0.01157	0.14789	616.7620	55.25	290000.0	84000.0	0.01167	0.06964
536.9610	55.05	302000.0	84000.0	0.01157	0.12973	617.9180	56.70	291000.0	84000.0	0.01167	0.06917
538.3320	53.80	301000.0	84000.0	0.01157	0.12054	619.0740	56.72	291000.0	84000.0	0.01168	0.08313
539.4800	53.03	301000.0	84000.0	0.01158	0.11376	620.4410	56.97	290000.0	84000.0	0.01168	0.08255
540.6910	54.78	301000.0	84000.0	0.01158	0.11471	621.5980	55.76	290000.0	84000.0	0.01167	0.08203
542.0120	54.43	301000.0	84000.0	0.01158	0.13191	622.8010	56.37	290000.0	84000.0	0.01168	0.08581
543.1600	55.21	301000.0	84000.0	0.01159	0.12284	623.9650	57.06	290000.0	84000.0	0.01169	0.08589
544.3200	53.89	301000.0	84000.0	0.01160	0.11552	625.3320	56.48	290000.0	84000.0	0.01169	0.08620
545.5200	53.56	301000.0	84000.0	0.01159	0.11775	626.4800	57.74	289000.0	84000.0	0.01168	0.08260
546.8400	53.72	300000.0	84000.0	0.01160	0.11759	627.6450	56.88	290000.0	84000.0	0.01167	0.08728
548.0510	56.21	300000.0	84000.0	0.01160	0.12031	629.0120	57.35	289000.0	84000.0	0.01168	0.08151
549.1990	55.54	300000.0	84000.0	0.01159	0.13341	630.1600	57.86	289000.0	84000.0	0.01169	0.07485
550.5820	55.30	300000.0	84000.0	0.01160	0.12501	631.3710	56.37	289000.0	84000.0	0.01168	0.06637
551.7300	55.70	299000.0	84000.0	0.01160	0.12739	632.5270	58.97	289000.0	84000.0	0.01168	0.07637
552.9410	55.54	300000.0	84000.0	0.01160	0.13978	633.9020	58.55	289000.0	84000.0	0.01169	0.08045
554.0900	56.90	299000.0	84000.0	0.01161	0.12497	635.0510	57.21	289000.0	84000.0	0.01168	0.07501
555.4100	53.92	299000.0	84000.0	0.01162	0.11280	636.2620	56.46	288000.0	85000.0	0.01169	0.08081
556.6210	55.50	299000.0	84000.0	0.01162	0.09743	637.5820	57.19	288000.0	85000.0	0.01169	0.07565
557.7700	55.68	299000.0	84000.0	0.01161	0.09412	639.8950	58.06	288000.0	85000.0	0.01170	0.08018
559.0900	55.32	298000.0	84000.0	0.01161	0.08045	641.2620	56.50	287000.0	85000.0	0.01170	0.08372
560.3010	55.50	298000.0	84000.0	0.01161	0.08955	642.4100	57.95	287000.0	85000.0	0.01170	0.07673
561.5120	55.16	298000.0	84000.0	0.01161	0.08515	643.5740	57.39	287000.0	85000.0	0.01169	0.08428
562.8320	54.76	298000.0	84000.0	0.01161	0.07912	644.7700	57.32	287000.0	85000.0	0.01170	0.08416
564.0310	55.16	298000.0	84000.0	0.01162	0.08854	646.1520	56.92	287000.0	85000.0	0.01171	0.08263
565.1910	54.27	297000.0	84000.0	0.01163	0.10698	647.3010	56.34	287000.0	85000.0	0.01171	0.07866

648.4490	57.99	287000.0	85000.0	0.01171	0.08808	729.5200	59.68	277000.0	84000.0	0.01177	0.08353
649.8320	58.77	287000.0	85000.0	0.01171	0.08171	730.7300	61.62	276000.0	84000.0	0.01177	0.07455
650.9340	56.61	287000.0	85000.0	0.01171	0.08055	732.0510	59.75	276000.0	84000.0	0.01178	0.06455
652.1290	57.66	287000.0	85000.0	0.01170	0.07574	733.1990	59.12	276000.0	85000.0	0.01177	0.06351
653.4020	58.68	286000.0	84000.0	0.01171	0.08300	734.3630	59.70	276000.0	84000.0	0.01178	0.06650
654.6130	53.14	287000.0	84000.0	0.01171	0.08844	735.5740	60.79	276000.0	84000.0	0.01178	0.06766
655.7620	57.32	286000.0	83000.0	0.01172	0.08776	736.8790	61.22	276000.0	84000.0	0.01177	0.05800
656.9100	57.50	286000.0	83000.0	0.01172	0.08799	738.0900	61.15	276000.0	84000.0	0.01177	0.04497
658.2930	57.28	286000.0	82000.0	0.01171	0.07591	739.2540	59.30	275000.0	84000.0	0.01178	0.04237
659.4410	58.86	286000.0	83000.0	0.01171	0.07409	740.5590	59.66	276000.0	84000.0	0.01178	0.04027
660.6520	59.21	285000.0	82000.0	0.01171	0.06832	741.7700	60.06	275000.0	84000.0	0.01177	0.03768
661.9730	58.77	285000.0	84000.0	0.01172	0.06695	742.9340	61.49	274000.0	84000.0	0.01178	0.04065
663.2300	58.37	285000.0	84000.0	0.01172	0.07339	744.3010	62.15	274000.0	84000.0	0.01178	0.03981
664.3790	57.83	286000.0	84000.0	0.01172	0.07917	745.4490	58.86	275000.0	84000.0	0.01177	0.04903
665.7620	56.94	284000.0	84000.0	0.01173	0.07773	746.6130	60.28	275000.0	84000.0	0.01177	0.05059
666.9100	57.72	285000.0	85000.0	0.01172	0.07891	747.7620	61.29	275000.0	84000.0	0.01178	0.05975
668.0590	59.75	284000.0	84000.0	0.01173	0.07775	749.0820	59.97	274000.0	85000.0	0.01177	0.05101
669.2700	91.10	284000.0	84000.0	0.01172	0.07733	750.2930	61.09	274000.0	84000.0	0.01178	0.03983
670.5900	59.37	284000.0	84000.0	0.01173	0.08282	751.4410	62.00	275000.0	84000.0	0.01177	0.03229
671.8010	59.23	284000.0	84000.0	0.01174	0.09103	752.8090	59.68	273000.0	84000.0	0.01178	0.03423
672.9490	59.64	283000.0	84000.0	0.01173	0.09046	753.9730	60.13	274000.0	84000.0	0.01179	0.03545
674.3240	59.59	283000.0	84000.0	0.01173	0.09486	755.1840	65.46	274000.0	84000.0	0.01179	0.03636
675.5270	57.63	283000.0	84000.0	0.01173	0.08857	756.3320	60.53	273000.0	84000.0	0.01179	0.03377
676.7380	61.42	283000.0	84000.0	0.01173	0.09074	757.6520	62.35	272000.0	84000.0	0.01178	0.03307
677.9020	58.37	282000.0	84000.0	0.01173	0.08668	758.8010	59.10	273000.0	83000.0	0.01179	0.03233
679.2150	59.46	283000.0	85000.0	0.01173	0.08475	759.9490	60.60	273000.0	84000.0	0.01179	0.03006
680.4800	58.12	283000.0	84000.0	0.01172	0.08420	761.2700	61.24	273000.0	84000.0	0.01179	0.02580
681.6290	57.86	282000.0	84000.0	0.01172	0.08650	762.4340	60.19	273000.0	85000.0	0.01178	0.02610
683.0040	58.68	283000.0	84000.0	0.01172	0.08832	763.6290	60.17	272000.0	86000.0	0.01178	0.02811
684.1600	60.13	282000.0	84000.0	0.01172	0.08237	764.9490	59.88	272000.0	85000.0	0.01178	0.02568
685.3630	62.30	282000.0	84000.0	0.01172	0.08143	766.1600	60.60	272000.0	84000.0	0.01178	0.02302
686.6840	60.35	282000.0	84000.0	0.01173	0.08121	767.3710	70.64	271000.0	85000.0	0.01178	0.02261
687.8950	58.92	282000.0	84000.0	0.01173	0.08227	768.5200	61.09	272000.0	84000.0	0.01178	0.01951
689.0980	57.97	282000.0	84000.0	0.01173	0.08842	769.9020	61.49	272000.0	84000.0	0.01178	0.01772
690.3090	58.99	281000.0	84000.0	0.01173	0.09441	771.0510	62.02	272000.0	84000.0	0.01179	0.01516
691.6290	59.72	281000.0	84000.0	0.01173	0.08835	772.2620	61.00	271000.0	85000.0	0.01179	0.01606
692.8320	58.59	282000.0	85000.0	0.01173	0.09130	773.5820	61.42	272000.0	84000.0	0.01180	0.01463
693.9880	58.08	281000.0	84000.0	0.01174	0.08906	774.7770	62.87	271000.0	84000.0	0.01180	0.01500
695.3630	58.10	281000.0	84000.0	0.01174	0.08388	775.8790	65.23	271000.0	85000.0	0.01180	0.01498
696.5120	57.94	279000.0	84000.0	0.01174	0.08494	777.1990	60.40	270000.0	84000.0	0.01180	0.01322
697.7230	58.41	280000.0	84000.0	0.01174	0.08212	778.4650	61.44	272000.0	84000.0	0.01181	0.01334
699.0430	58.75	280000.0	84000.0	0.01175	0.08489	779.6210	62.80	270000.0	84000.0	0.01181	0.01226
700.1910	58.37	280000.0	84000.0	0.01175	0.09418	780.8320	63.31	271000.0	84000.0	0.01181	0.01082
701.4650	60.24	280000.0	83000.0	0.01174	0.10552	782.1450	63.33	270000.0	84000.0	0.01181	0.01032
702.6130	58.21	280000.0	84000.0	0.01174	0.10244	783.4100	61.15	270000.0	84000.0	0.01180	0.01273
703.9800	60.28	280000.0	84000.0	0.01175	0.10379	784.6210	62.31	270000.0	84000.0	0.01180	0.01100
705.1450	58.35	280000.0	84000.0	0.01174	0.11504	785.9340	63.22	271000.0	84000.0	0.01181	0.01164
706.3480	59.17	279000.0	83000.0	0.01174	0.11276	787.0900	61.80	270000.0	84000.0	0.01181	0.01105
707.6600	57.95	280000.0	84000.0	0.01175	0.11246	788.3480	63.76	270000.0	84000.0	0.01181	0.00992
708.8710	59.19	279000.0	84000.0	0.01175	0.11702	789.6680	63.27	270000.0	85000.0	0.01180	0.01029
710.0270	60.04	279000.0	84000.0	0.01176	0.10733	790.8240	62.40	270000.0	84000.0	0.01180	0.01209
711.2930	61.09	278000.0	84000.0	0.01175	0.10820	792.0270	61.75	270000.0	84000.0	0.01181	0.01129
712.5040	60.15	278000.0	84000.0	0.01175	0.09110	793.1840	61.13	269000.0	84000.0	0.01181	0.01012
713.6520	60.66	279000.0	84000.0	0.01174	0.08273	794.5040	63.04	269000.0	84000.0	0.01181	0.00993
714.8630	58.81	278000.0	84000.0	0.01174	0.08706	795.6600	62.80	269000.0	84000.0	0.01181	0.01216
716.1840	59.55	278000.0	84000.0	0.01175	0.09553	796.8630	61.93	269000.0	84000.0	0.01182	0.01072
717.3950	60.80	278000.0	84000.0	0.01175	0.09519	798.1840	61.75	268000.0	85000.0	0.01183	0.01020
718.5430	61.24	278000.0	84000.0	0.01176	0.09515	799.3950	61.51	269000.0	84000.0	0.01182	0.00935
719.8630	59.73	278000.0	84000.0	0.01176	0.11354	800.5430	63.76	268000.0	84000.0	0.01183	0.00994
721.0120	59.06	278000.0	84000.0	0.01176	0.11284	801.6990	62.15	268000.0	84000.0	0.01183	0.00915
722.1600	59.97	278000.0	84000.0	0.01177	0.12035	803.1290	63.64	268000.0	84000.0	0.01183	0.00849
723.3710	61.13	278000.0	85000.0	0.01177	0.12669	804.2770	63.91	268000.0	84000.0	0.01182	0.00801
724.6910	58.86	278000.0	84000.0	0.01176	0.12247	805.4880	62.04	268000.0	84000.0	0.01181	0.00782
725.8400	58.99	278000.0	84000.0	0.01177	0.12252	806.7540	62.40	267000.0	84000.0	0.01182	0.00827
727.0040	61.62	277000.0	84000.0	0.01178	0.11498	807.9650	63.82	267000.0	84000.0	0.01182	0.00850
728.3710	59.39	277000.0	84000.0	0.01178	0.09925	809.1680	62.91	268000.0	85000.0	0.01182	0.00811

810.5430	60.66	267000.0	84000.0	0.01183	0.00771	891.2300	64.89	259000.0	85000.0	0.01190	0.01019
811.7540	62.82	267000.0	84000.0	0.01183	0.00828	892.4340	63.76	259000.0	85000.0	0.01190	0.00924
812.9020	61.71	267000.0	85000.0	0.01183	0.00793	893.7540	65.22	259000.0	85000.0	0.01190	0.01082
814.1130	62.67	267000.0	84000.0	0.01183	0.00881	894.9650	63.78	259000.0	85000.0	0.01190	0.01554
815.4340	64.07	267000.0	84000.0	0.01183	0.00870	896.1130	63.78	258000.0	85000.0	0.01189	0.01467
816.5820	62.04	266000.0	84000.0	0.01183	0.00960	897.4880	64.91	258000.0	85000.0	0.01189	0.01459
817.7930	62.07	267000.0	85000.0	0.01182	0.00953	898.6450	66.25	258000.0	85000.0	0.01189	0.01246
819.1600	63.55	266000.0	84000.0	0.01183	0.01187	899.9020	65.53	258000.0	85000.0	0.01191	0.01216
820.3240	62.98	266000.0	84000.0	0.01184	0.01052	901.1680	66.56	258000.0	85000.0	0.01191	0.01219
821.4730	62.22	266000.0	85000.0	0.01184	0.00958	902.3240	62.00	258000.0	85000.0	0.01190	0.01079
822.8400	64.69	266000.0	84000.0	0.01185	0.00878	903.5820	65.22	257000.0	85000.0	0.01191	0.00972
824.0040	64.13	266000.0	84000.0	0.01185	0.00831	904.7930	65.69	258000.0	85000.0	0.01191	0.00893
825.1520	64.38	266000.0	85000.0	0.01185	0.00789	906.1680	66.52	257000.0	85000.0	0.01191	0.01256
826.3010	62.85	266000.0	84000.0	0.01185	0.00772	907.3240	64.67	257000.0	85000.0	0.01191	0.03729
827.6210	63.20	266000.0	84000.0	0.01185	0.00752	908.5270	65.80	257000.0	85000.0	0.01190	0.05144
828.8320	62.27	267000.0	84000.0	0.01184	0.00736	909.8480	64.04	257000.0	85000.0	0.01191	0.05374
829.9800	63.18	265000.0	84000.0	0.01184	0.00906	911.0510	65.38	257000.0	85000.0	0.01190	0.05216
831.3630	62.31	265000.0	85000.0	0.01183	0.00908	912.2150	65.49	256000.0	85000.0	0.01191	0.06212
832.5120	62.64	264000.0	84000.0	0.01183	0.00902	913.3630	65.40	257000.0	85000.0	0.01190	0.05751
833.6600	63.31	266000.0	84000.0	0.01183	0.00856	914.7300	66.76	256000.0	85000.0	0.01190	0.04589
834.8240	62.98	266000.0	84000.0	0.01184	0.00814	915.9410	66.83	256000.0	85000.0	0.01190	0.04089
836.1910	62.22	265000.0	84000.0	0.01184	0.00780	917.0980	64.18	256000.0	85000.0	0.01190	0.03682
837.3400	62.47	265000.0	85000.0	0.01183	0.00759	918.4100	64.29	256000.0	85000.0	0.01191	0.04045
838.5510	62.29	264000.0	85000.0	0.01184	0.00808	919.6210	65.60	254000.0	84000.0	0.01191	0.04500
839.8240	63.04	264000.0	85000.0	0.01185	0.00777	920.7770	64.47	256000.0	85000.0	0.01190	0.03812
841.0200	64.02	264000.0	84000.0	0.01185	0.01008	922.1520	65.11	255000.0	85000.0	0.01192	0.03575
842.2300	62.35	264000.0	85000.0	0.01185	0.01041	923.3010	65.20	255000.0	85000.0	0.01192	0.03898
843.5510	63.82	263000.0	84000.0	0.01185	0.01002	924.5120	66.47	255000.0	85000.0	0.01192	0.03737
844.6990	65.11	264000.0	84000.0	0.01185	0.01123	925.6600	65.27	255000.0	85000.0	0.01193	0.03377
845.8630	64.16	264000.0	85000.0	0.01185	0.01149	927.0430	67.45	255000.0	85000.0	0.01192	0.03374
847.0740	62.60	262000.0	85000.0	0.01185	0.01082	928.1910	65.07	255000.0	85000.0	0.01191	0.03269
848.3790	65.34	263000.0	85000.0	0.01186	0.01212	929.4020	65.31	255000.0	85000.0	0.01191	0.03335
849.6520	64.53	263000.0	85000.0	0.01186	0.01271	930.7230	66.32	254000.0	85000.0	0.01191	0.02910
850.8010	64.80	263000.0	85000.0	0.01185	0.01114	931.9800	64.71	254000.0	85000.0	0.01191	0.02689
852.1680	62.78	262000.0	85000.0	0.01186	0.00986	933.1290	66.92	254000.0	85000.0	0.01191	0.02718
853.3320	62.98	262000.0	85000.0	0.01187	0.00969	934.4490	65.05	254000.0	85000.0	0.01191	0.02437
854.4800	64.58	263000.0	85000.0	0.01186	0.00959	935.6600	66.45	254000.0	85000.0	0.01191	0.02379
855.8010	65.38	262000.0	85000.0	0.01187	0.00877	936.8090	67.67	255000.0	85000.0	0.01192	0.02100
857.0590	63.93	262000.0	84000.0	0.01187	0.00822	938.0200	66.47	254000.0	85000.0	0.01192	0.02478
858.2230	62.95	262000.0	84000.0	0.01188	0.00787	939.3400	67.85	254000.0	85000.0	0.01192	0.02537
859.3090	65.29	261000.0	85000.0	0.01187	0.00771	940.5980	67.07	254000.0	85000.0	0.01191	0.02234
860.6910	64.69	261000.0	85000.0	0.01187	0.00811	941.8090	63.18	253000.0	85000.0	0.01192	0.02131
861.8400	64.11	262000.0	84000.0	0.01187	0.00846	943.1290	67.61	253000.0	85000.0	0.01192	0.02584
863.0510	62.84	261000.0	85000.0	0.01187	0.00869	944.3400	65.49	253000.0	84000.0	0.01192	0.02459
864.3710	63.11	263000.0	84000.0	0.01188	0.00870	945.5510	65.58	254000.0	84000.0	0.01193	0.03010
865.5820	65.76	261000.0	85000.0	0.01188	0.00953	946.8090	65.63	253000.0	85000.0	0.01192	0.02776
866.7300	63.71	261000.0	84000.0	0.01187	0.00948	948.0200	67.94	253000.0	85000.0	0.01192	0.02505
868.0510	65.27	261000.0	85000.0	0.01187	0.00872	949.2300	65.54	253000.0	85000.0	0.01192	0.02787
869.1990	65.22	261000.0	84000.0	0.01186	0.00825	950.3790	67.85	253000.0	85000.0	0.01192	0.02431
870.4650	64.47	261000.0	85000.0	0.01187	0.00923	951.7540	67.50	252000.0	84000.0	0.01192	0.02547
871.6210	62.93	260000.0	85000.0	0.01187	0.00927	952.9100	66.61	252000.0	84000.0	0.01192	0.02579
872.9880	65.83	260000.0	85000.0	0.01187	0.00857	954.1210	67.36	252000.0	84000.0	0.01193	0.02876
874.1450	65.27	260000.0	85000.0	0.01188	0.00813	955.4340	65.45	252000.0	85000.0	0.01193	0.03214
875.3010	65.76	260000.0	84000.0	0.01189	0.00782	956.6450	67.32	252000.0	85000.0	0.01193	0.02677
876.6210	65.34	259000.0	84000.0	0.01189	0.00897	957.8480	65.71	252000.0	85000.0	0.01193	0.02467
877.7700	65.60	261000.0	85000.0	0.01188	0.00840	959.1130	65.87	252000.0	85000.0	0.01194	0.02563
878.9800	65.09	260000.0	85000.0	0.01189	0.01054	960.4340	67.63	252000.0	85000.0	0.01193	0.03709
880.1290	64.27	260000.0	85000.0	0.01189	0.00950	961.6450	66.07	251000.0	84000.0	0.01194	0.04074
881.4490	84.21	260000.0	85000.0	0.01189	0.00935	962.7930	65.94	251000.0	85000.0	0.01194	0.03962
882.5980	64.02	260000.0	85000.0	0.01190	0.00871	964.1130	66.81	251000.0	85000.0	0.01194	0.03877
883.8090	64.58	260000.0	85000.0	0.01189	0.00814	965.2700	66.34	251000.0	85000.0	0.01194	0.05027
885.1290	65.05	259000.0	85000.0	0.01189	0.00786	966.4180	66.18	250000.0	85000.0	0.01195	0.05243
886.3400	60.63	260000.0	85000.0	0.01189	0.00760	967.7930	66.09	251000.0	85000.0	0.01195	0.05487
887.5510	67.88	259000.0	84000.0	0.01189	0.01141	968.9490	66.61	252000.0	85000.0	0.01195	0.04717
888.8630	64.91	259000.0	85000.0	0.01190	0.01221	970.1520	68.23	251000.0	85000.0	0.01193	0.04662
890.0740	65.38	259000.0	85000.0	0.01190	0.01142	971.3090	67.34	250000.0	85000.0	0.01194	0.04749



972.6840	69.95	250000.0	84000.0	0.01194	0.05323	1054.7380	68.76	242000.0	85000.0	0.01198	0.23028
973.7770	68.54	250000.0	85000.0	0.01194	0.05822	1055.8950	68.76	242000.0	85000.0	0.01198	0.22594
974.9880	67.14	250000.0	85000.0	0.01194	0.06076	1057.1600	69.54	242000.0	85000.0	0.01198	0.23597
976.2540	68.85	250000.0	85000.0	0.01193	0.06266	1058.4180	68.41	242000.0	84000.0	0.01197	0.24490
977.4650	66.09	250000.0	85000.0	0.01193	0.05994	1059.6290	69.34	241000.0	84000.0	0.01198	0.25383
978.6680	67.36	250000.0	85000.0	0.01193	0.05612	1060.7770	70.08	241000.0	84000.0	0.01199	0.25809
979.9880	68.81	249000.0	85000.0	0.01194	0.05340	1061.9880	70.32	241000.0	84000.0	0.01198	0.26196
981.1910	66.79	249000.0	84000.0	0.01194	0.05374	1063.3630	70.30	241000.0	84000.0	0.01198	0.26449
982.3480	69.30	249000.0	85000.0	0.01194	0.05223	1064.5740	71.52	241000.0	85000.0	0.01199	0.26311
983.5590	67.14	249000.0	84000.0	0.01194	0.04802	1065.7770	69.99	241000.0	85000.0	0.01199	0.25288
984.8240	69.42	248000.0	85000.0	0.01193	0.05206	1067.0980	70.97	241000.0	84000.0	0.01198	0.26818
986.0820	66.34	249000.0	85000.0	0.01194	0.06171	1068.3090	70.94	241000.0	85000.0	0.01199	0.26400
987.2380	68.59	249000.0	85000.0	0.01195	0.08243	1069.4650	69.01	241000.0	86000.0	0.01199	0.25677
988.6130	69.01	248000.0	84000.0	0.01195	0.10710	1070.6680	70.39	240000.0	84000.0	0.01198	0.23533
989.7620	67.83	248000.0	84000.0	0.01195	0.11392	1071.9880	68.85	240000.0	85000.0	0.01198	0.22009
990.9730	66.50	248000.0	84000.0	0.01195	0.12062	1073.1910	70.65	240000.0	85000.0	0.01198	0.22009
992.1210	69.23	248000.0	84000.0	0.01195	0.12811	1074.3480	72.94	240000.0	84000.0	0.01197	0.20746
993.5040	69.34	247000.0	85000.0	0.01195	0.13527	1075.6680	71.61	240000.0	85000.0	0.01197	0.20888
994.6520	69.34	249000.0	85000.0	0.01195	0.14437	1076.8710	70.99	240000.0	84000.0	0.01198	0.19608
995.8630	67.87	249000.0	84000.0	0.01195	0.15335	1078.0270	66.92	240000.0	84000.0	0.01198	0.20432
997.1840	69.32	248000.0	84000.0	0.01194	0.15748	1079.4020	71.55	240000.0	86000.0	0.01198	0.18936
999.5430	67.76	248000.0	85000.0	0.01194	0.15892	1080.5510	65.62	241000.0	84000.0	0.01198	0.16276
1000.8010	68.76	248000.0	84000.0	0.01195	0.15052	1081.7150	69.65	240000.0	84000.0	0.01199	0.14639
1002.0120	69.19	247000.0	84000.0	0.01194	0.15747	1082.9180	70.25	240000.0	85000.0	0.01198	0.13467
1003.1600	68.23	247000.0	84000.0	0.01195	0.15137	1084.2930	71.46	240000.0	85000.0	0.01199	0.13465
1004.3710	65.46	247000.0	84000.0	0.01195	0.15225	1085.4410	69.61	239000.0	84000.0	0.01198	0.13199
1005.6910	68.45	248000.0	85000.0	0.01195	0.14758	1086.6520	70.99	239000.0	84000.0	0.01199	0.12700
1006.9020	69.14	247000.0	84000.0	0.01195	0.13971	1087.9100	71.37	240000.0	84000.0	0.01200	0.11621
1008.1130	69.68	247000.0	84000.0	0.01195	0.13121	1089.0740	71.70	239000.0	85000.0	0.01199	0.12436
1009.4800	67.12	247000.0	84000.0	0.01196	0.13183	1090.2770	72.00	239000.0	85000.0	0.01199	0.11278
1010.6290	69.68	247000.0	85000.0	0.01196	0.14020	1091.5900	71.57	239000.0	84000.0	0.01199	0.11931
1011.8400	67.96	247000.0	85000.0	0.01197	0.13966	1092.7540	69.37	240000.0	84000.0	0.01199	0.11381
1013.1600	68.46	247000.0	84000.0	0.01196	0.13380	1093.9020	70.63	239000.0	85000.0	0.01199	0.10967
1014.3710	69.34	247000.0	84000.0	0.01196	0.12602	1095.1130	71.03	238000.0	86000.0	0.01199	0.09909
1015.5200	69.76	246000.0	84000.0	0.01196	0.12041	1096.4800	69.79	238000.0	84000.0	0.01199	0.08399
1016.6840	67.99	246000.0	84000.0	0.01197	0.13230	1097.6910	72.17	238000.0	84000.0	0.01198	0.09672
1018.0510	69.16	246000.0	84000.0	0.01195	0.13620	1098.8400	72.08	238000.0	85000.0	0.01200	0.13902
1019.1990	67.39	246000.0	84000.0	0.01195	0.12882	1100.1600	69.79	238000.0	85000.0	0.01200	0.18057
1020.3630	67.68	246000.0	85000.0	0.01196	0.13278	1101.3240	71.88	238000.0	85000.0	0.01199	0.17293
1021.7300	67.56	246000.0	85000.0	0.01196	0.13255	1102.5200	71.79	238000.0	84000.0	0.01199	0.14442
1022.9410	68.16	246000.0	85000.0	0.01196	0.14184	1103.8400	70.25	237000.0	84000.0	0.01199	0.13020
1024.0900	68.85	245000.0	84000.0	0.01196	0.14663	1105.0510	70.23	237000.0	85000.0	0.01199	0.11260
1025.4100	69.97	245000.0	85000.0	0.01196	0.15887	1106.1990	70.41	237000.0	84000.0	0.01199	0.09283
1026.6210	69.23	245000.0	85000.0	0.01196	0.16782	1107.4100	72.73	237000.0	84000.0	0.01199	0.09020
1027.7700	68.74	245000.0	84000.0	0.01196	0.18629	1108.6840	70.43	236000.0	84000.0	0.01199	0.07428
1028.9180	68.85	244000.0	84000.0	0.01197	0.20512	1109.8790	71.86	237000.0	84000.0	0.01199	0.05929
1030.2380	66.56	245000.0	85000.0	0.01198	0.21392	1111.0430	113.30	237000.0	84000.0	0.01199	0.06178
1031.4490	69.92	245000.0	84000.0	0.01197	0.21964	1112.4100	70.25	237000.0	84000.0	0.01199	0.05112
1032.5980	68.08	245000.0	84000.0	0.01197	0.20958	1113.5590	71.19	237000.0	84000.0	0.01198	0.05640
1033.9180	68.56	244000.0	85000.0	0.01197	0.21000	1114.7700	73.24	236000.0	84000.0	0.01199	0.06028
1035.0820	68.56	244000.0	85000.0	0.01196	0.20862	1115.9340	70.34	236000.0	84000.0	0.01199	0.05382
1036.2770	67.85	244000.0	85000.0	0.01196	0.21460	1117.3010	72.84	236000.0	86000.0	0.01198	0.03981
1037.4410	67.72	244000.0	84000.0	0.01196	0.20569	1118.4490	73.29	235000.0	84000.0	0.01198	0.03102
1038.7620	68.70	243000.0	85000.0	0.01196	0.20573	1119.6130	72.42	236000.0	84000.0	0.01199	0.02474
1039.9100	69.25	244000.0	84000.0	0.01197	0.20327	1120.9800	73.53	236000.0	83000.0	0.01200	0.02222
1041.0590	70.92	243000.0	85000.0	0.01196	0.19824	1122.1290	70.85	236000.0	83000.0	0.01200	0.01928
1042.4410	69.65	243000.0	84000.0	0.01197	0.20371	1123.3400	71.57	236000.0	83000.0	0.01200	0.01665
1043.6450	70.99	243000.0	85000.0	0.01197	0.20722	1124.6600	71.43	236000.0	81000.0	0.01199	0.01387
1044.8010	68.54	243000.0	84000.0	0.01197	0.20318	1125.8710	72.44	236000.0	82000.0	0.01200	0.01210
1046.1210	70.86	243000.0	84000.0	0.01197	0.19116	1127.0200	73.25	236000.0	83000.0	0.01201	0.01083
1047.3240	68.83	243000.0	84000.0	0.01197	0.19088	1128.1680	73.67	235000.0	82000.0	0.01200	0.00993
1048.5270	70.61	242000.0	84000.0	0.01198	0.19500	1129.4880	72.80	235000.0	82000.0	0.01200	0.00917
1049.6910	68.56	242000.0	84000.0	0.01198	0.20336	1130.6520	72.04	235000.0	82000.0	0.01199	0.00868
1051.0040	70.14	244000.0	84000.0	0.01198	0.21782	1131.9100	71.35	235000.0	82000.0	0.01199	0.00819
1052.2150	69.08	242000.0	84000.0	0.01198	0.22330	1133.2300	74.40	236000.0	83000.0	0.01199	0.01084
1053.3710	71.08	241000.0	84000.0	0.01198	0.22141	1134.4410	71.66	235000.0	84000.0	0.01199	0.01116

1135.5900	71.91	235000.0	83000.0	0.01199	0.01191	1216.7150	74.86	228000.0	83000.0	0.01201	0.00703
1136.9650	74.27	234000.0	85000.0	0.01200	0.01043	1217.9180	76.96	227000.0	82000.0	0.01201	0.00703
1138.1210	72.29	234000.0	84000.0	0.01199	0.00956	1219.1910	77.23	227000.0	83000.0	0.01202	0.00703
1139.3240	72.69	234000.0	85000.0	0.01200	0.00892	1220.4490	76.74	227000.0	83000.0	0.01202	0.00703
1140.5270	73.13	234000.0	85000.0	0.01200	0.00844	1221.6600	74.88	227000.0	83000.0	0.01201	0.00704
1141.8480	74.72	234000.0	85000.0	0.01201	0.00807	1222.8090	75.33	228000.0	82000.0	0.01200	0.00694
1143.0040	71.97	234000.0	84000.0	0.01201	0.00784	1224.1290	76.27	227000.0	82000.0	0.01200	0.00699
1144.2700	74.27	235000.0	84000.0	0.01201	0.00766	1225.3400	77.99	225000.0	82000.0	0.01200	0.00698
1145.5900	74.25	234000.0	85000.0	0.01201	0.00751	1226.4880	75.19	226000.0	82000.0	0.01200	0.00699
1146.7930	72.42	233000.0	85000.0	0.01200	0.00733	1227.6990	77.68	227000.0	83000.0	0.01202	0.00702
1147.9490	72.77	233000.0	84000.0	0.01200	0.00736	1229.0200	77.67	226000.0	82000.0	0.01201	0.00701
1149.1600	74.20	233000.0	84000.0	0.01200	0.00729	1230.2300	76.06	226000.0	82000.0	0.01201	0.00703
1150.4730	75.03	233000.0	85000.0	0.01200	0.00725	1231.3790	76.09	226000.0	83000.0	0.01201	0.00698
1151.6840	74.94	233000.0	86000.0	0.01201	0.00719	1232.6990	75.37	226000.0	83000.0	0.01201	0.00701
1152.8950	75.30	233000.0	85000.0	0.01201	0.00718	1233.9100	77.34	227000.0	82000.0	0.01201	0.00702
1154.2150	74.29	233000.0	85000.0	0.01201	0.00710	1235.0590	76.00	225000.0	83000.0	0.01202	0.00697
1155.4180	73.22	233000.0	85000.0	0.01201	0.00716	1236.3790	78.41	226000.0	82000.0	0.01202	0.00703
1156.5740	72.95	233000.0	85000.0	0.01201	0.00715	1237.5270	78.37	226000.0	82000.0	0.01201	0.00701
1157.8950	74.38	232000.0	85000.0	0.01200	0.00714	1238.7380	76.31	225000.0	82000.0	0.01201	0.00701
1159.0430	74.09	232000.0	84000.0	0.01200	0.00713	1239.9490	78.01	225000.0	83000.0	0.01201	0.00692
1160.3090	73.18	232000.0	84000.0	0.01200	0.00713	1241.2700	75.62	225000.0	82000.0	0.01202	0.00701
1161.5120	72.78	232000.0	85000.0	0.01200	0.00712	1242.4730	77.92	225000.0	83000.0	0.01202	0.00701
1162.8950	72.51	233000.0	84000.0	0.01201	0.00711	1243.6290	75.89	224000.0	83000.0	0.01201	0.00702
1164.0430	73.40	232000.0	85000.0	0.01201	0.00711	1244.9490	76.78	225000.0	84000.0	0.01201	0.00702
1165.2540	73.91	232000.0	84000.0	0.01200	0.00705	1246.0980	76.90	225000.0	83000.0	0.01201	0.00701
1166.5120	73.16	232000.0	85000.0	0.01200	0.00708	1247.3090	75.44	223000.0	83000.0	0.01200	0.00692
1167.7230	75.17	232000.0	85000.0	0.01200	0.00710	1248.6290	77.85	224000.0	83000.0	0.01201	0.00701
1168.9340	74.52	232000.0	85000.0	0.01200	0.00708	1249.7770	75.56	224000.0	83000.0	0.01200	0.00701
1170.2540	75.55	232000.0	85000.0	0.01200	0.00709	1251.0430	77.90	224000.0	83000.0	0.01201	0.00693
1171.4020	73.31	231000.0	84000.0	0.01200	0.00708	1252.1990	78.44	224000.0	83000.0	0.01202	0.00701
1172.6130	73.49	231000.0	84000.0	0.01200	0.00708	1253.5740	76.98	224000.0	82000.0	0.01202	0.00701
1173.8710	75.23	231000.0	85000.0	0.01200	0.00709	1254.7230	78.57	224000.0	82000.0	0.01203	0.00701
1175.1450	77.79	231000.0	85000.0	0.01200	0.00708	1255.9340	75.96	223000.0	83000.0	0.01203	0.00701
1176.3400	73.40	231000.0	84000.0	0.01200	0.00707	1257.2540	78.35	224000.0	81000.0	0.01202	0.00702
1177.5040	75.12	231000.0	84000.0	0.01200	0.00696	1258.4650	78.50	224000.0	83000.0	0.01202	0.00698
1178.8710	73.72	231000.0	84000.0	0.01199	0.00708	1259.6680	76.94	224000.0	83000.0	0.01202	0.00701
1180.0200	75.17	231000.0	85000.0	0.01200	0.00702	1260.9800	78.68	224000.0	84000.0	0.01201	0.00700
1181.1840	74.79	230000.0	84000.0	0.01200	0.00706	1262.1910	76.76	223000.0	83000.0	0.01201	0.00700
1182.5040	73.40	230000.0	84000.0	0.01201	0.00703	1263.4020	78.80	223000.0	83000.0	0.01201	0.00700
1183.7620	74.50	229000.0	84000.0	0.01201	0.00706	1264.5510	78.55	223000.0	84000.0	0.01201	0.00700
1184.9100	76.31	230000.0	85000.0	0.01201	0.00707	1265.8710	82.32	223000.0	83000.0	0.01201	0.00690
1186.0740	76.35	230000.0	85000.0	0.01201	0.00702	1267.0820	77.12	223000.0	82000.0	0.01201	0.00702
1187.4410	74.97	230000.0	84000.0	0.01201	0.00707	1268.2300	80.03	223000.0	83000.0	0.01202	0.00694
1188.5900	76.31	230000.0	85000.0	0.01201	0.00698	1269.5510	78.73	223000.0	83000.0	0.01202	0.00702
1189.8010	75.01	230000.0	84000.0	0.01200	0.00978	1270.7150	76.47	223000.0	83000.0	0.01202	0.00698
1191.0590	76.02	230000.0	84000.0	0.01200	0.01053	1271.9100	76.61	223000.0	83000.0	0.01202	0.00700
1192.2700	75.01	230000.0	83000.0	0.01201	0.00957	1273.0740	77.81	223000.0	83000.0	0.01201	0.00701
1193.4340	74.27	229000.0	84000.0	0.01200	0.00878	1274.3950	79.22	223000.0	83000.0	0.01202	0.00697
1194.5820	76.02	229000.0	82000.0	0.01201	0.00839	1275.5430	76.72	222000.0	83000.0	0.01203	0.00700
1195.9020	75.42	229000.0	82000.0	0.01201	0.00798	1276.7540	78.50	223000.0	83000.0	0.01202	0.00695
1197.0510	76.64	229000.0	82000.0	0.01201	0.00761	1278.0740	79.38	222000.0	83000.0	0.01202	0.00702
1198.2620	69.88	229000.0	82000.0	0.01200	0.00754	1279.2700	78.95	221000.0	83000.0	0.01201	0.00700
1199.5820	75.46	229000.0	82000.0	0.01200	0.00739	1280.4340	79.17	222000.0	83000.0	0.01201	0.00701
1200.7300	73.99	229000.0	82000.0	0.01200	0.00730	1281.7540	73.70	222000.0	83000.0	0.01201	0.00695
1201.8790	76.38	229000.0	82000.0	0.01200	0.00712	1282.9490	77.73	222000.0	83000.0	0.01201	0.00700
1203.2620	75.17	229000.0	83000.0	0.01201	0.00716	1284.1600	79.33	222000.0	84000.0	0.01201	0.00698
1204.4100	76.49	228000.0	82000.0	0.01200	0.00704	1285.3710	77.41	222000.0	83000.0	0.01201	0.00731
1205.6210	77.29	228000.0	82000.0	0.01201	0.00711	1286.6910	79.11	222000.0	85000.0	0.01201	0.00817
1206.7700	76.56	228000.0	82000.0	0.01201	0.00709	1287.8400	79.47	222000.0	83000.0	0.01201	0.01003
1208.1520	74.68	228000.0	82000.0	0.01200	0.00707	1289.1130	79.62	222000.0	85000.0	0.01201	0.01153
1209.3010	76.15	228000.0	82000.0	0.01200	0.00706	1290.4180	78.93	222000.0	83000.0	0.01200	0.01160
1210.5120	77.61	228000.0	82000.0	0.01200	0.00705	1291.5820	77.63	222000.0	83000.0	0.01201	0.01033
1211.8320	75.69	229000.0	82000.0	0.01200	0.00705	1292.7930	77.48	221000.0	84000.0	0.01201	0.00965
1213.0270	74.57	228000.0	82000.0	0.01199	0.00698	1294.0980	78.17	221000.0	84000.0	0.01201	0.01045
1214.1910	77.52	228000.0	83000.0	0.01200	0.00704	1295.2620	77.44	221000.0	84000.0	0.01201	0.01967
1215.5120	74.50	228000.0	82000.0	0.01200	0.00706	1296.4730	79.54	221000.0	84000.0	0.01200	0.02358

1297.6210	79.45	221000.0	84000.0	0.01200	0.02456	1378.8480	83.50	214000.0	97000.0	0.01183	0.24657
1298.9880	83.53	221000.0	84000.0	0.01200	0.03159	1380.0120	83.88	214000.0	99000.0	0.01182	0.24891
1300.1520	79.92	220000.0	84000.0	0.01201	0.04824	1381.3320	82.16	214000.0	100000.0	0.01180	0.25414
1301.3010	80.47	221000.0	84000.0	0.01200	0.04922	1382.5270	82.02	214000.0	100000.0	0.01178	0.25880
1302.6680	78.22	220000.0	84000.0	0.01200	0.04172	1383.8010	83.19	214000.0	101000.0	0.01176	0.26330
1303.8320	78.73	220000.0	84000.0	0.01201	0.03926	1385.0590	82.12	213000.0	100000.0	0.01174	0.26636
1305.0270	79.78	220000.0	85000.0	0.01202	0.04792	1386.3790	80.91	213000.0	100000.0	0.01174	0.26795
1306.1910	80.68	220000.0	84000.0	0.01201	0.05912	1387.6450	84.28	213000.0	101000.0	0.01174	0.26942
1307.5590	80.32	220000.0	85000.0	0.01202	0.07524	1388.9100	84.20	213000.0	102000.0	0.01172	0.27200
1308.7150	79.83	220000.0	84000.0	0.01201	0.08035	1390.2770	82.70	213000.0	103000.0	0.01171	0.27593
1309.9180	78.29	220000.0	84000.0	0.01200	0.06398	1391.5430	83.95	213000.0	101000.0	0.01169	0.27778
1311.2380	80.81	220000.0	85000.0	0.01200	0.07474	1392.7540	84.51	213000.0	102000.0	0.01169	0.27790
1312.4490	80.52	219000.0	85000.0	0.01201	0.07537	1394.1210	83.75	212000.0	103000.0	0.01167	0.28163
1313.5980	80.03	219000.0	85000.0	0.01201	0.07892	1395.3320	84.35	213000.0	103000.0	0.01167	0.28404
1314.9180	78.09	219000.0	86000.0	0.01201	0.09296	1396.5430	83.12	213000.0	103000.0	0.01165	0.28514
1316.1290	79.80	220000.0	86000.0	0.01201	0.08845	1397.7540	82.61	213000.0	103000.0	0.01164	0.28708
1317.3400	80.57	219000.0	85000.0	0.01201	0.08890	1399.1210	83.86	213000.0	104000.0	0.01163	0.28948
1318.5510	79.58	220000.0	85000.0	0.01201	0.09002	1400.3320	85.45	213000.0	104000.0	0.01161	0.29127
1319.9180	81.28	219000.0	85000.0	0.01200	0.10184	1401.6520	83.39	213000.0	105000.0	0.01160	0.29448
1321.0740	80.88	218000.0	85000.0	0.01200	0.10708	1402.9730	85.40	212000.0	105000.0	0.01158	0.29774
1322.2770	80.43	219000.0	85000.0	0.01199	0.10545	1404.2300	73.78	212000.0	105000.0	0.01157	0.30047
1323.5980	80.39	219000.0	85000.0	0.01199	0.09628	1405.4410	84.34	211000.0	106000.0	0.01154	0.30287
1324.8090	83.11	220000.0	86000.0	0.01199	0.09253	1406.8710	83.84	212000.0	106000.0	0.01151	0.30538
1325.9650	78.69	219000.0	85000.0	0.01200	0.09786	1408.1290	85.09	212000.0	106000.0	0.01150	0.30691
1327.2770	80.10	220000.0	86000.0	0.01199	0.09781	1409.3400	85.41	212000.0	107000.0	0.01149	0.30919
1328.4340	80.88	220000.0	87000.0	0.01200	0.10575	1410.5980	83.57	211000.0	107000.0	0.01146	0.31153
1329.5900	81.53	218000.0	86000.0	0.01200	0.11849	1411.9180	83.46	211000.0	107000.0	0.01145	0.31398
1330.7930	81.33	219000.0	87000.0	0.01200	0.12333	1413.0740	83.66	212000.0	108000.0	0.01142	0.31487
1332.1680	81.19	218000.0	86000.0	0.01199	0.13032	1414.2770	86.02	211000.0	108000.0	0.01141	0.31662
1333.3240	81.46	217000.0	86000.0	0.01199	0.12960	1415.5980	84.22	211000.0	108000.0	0.01140	0.31900
1334.5270	79.65	218000.0	88000.0	0.01200	0.13290	1416.8090	84.56	211000.0	109000.0	0.01138	0.32059
1335.8480	81.19	219000.0	86000.0	0.01200	0.13441	1417.9650	87.27	211000.0	109000.0	0.01137	0.32275
1337.1130	80.75	217000.0	88000.0	0.01199	0.13592	1419.2770	84.43	212000.0	109000.0	0.01136	0.32436
1338.3240	80.72	218000.0	86000.0	0.01198	0.14072	1420.4880	87.11	211000.0	109000.0	0.01134	0.32619
1339.6450	78.83	217000.0	88000.0	0.01198	0.14293	1421.6990	87.16	211000.0	109000.0	0.01133	0.32649
1340.8480	80.03	217000.0	87000.0	0.01198	0.14851	1422.9020	85.88	211000.0	109000.0	0.01132	0.32704
1342.0040	79.27	217000.0	87000.0	0.01197	0.15099	1424.2770	86.89	211000.0	109000.0	0.01131	0.32754
1343.2150	79.54	217000.0	89000.0	0.01198	0.15618	1425.4340	87.43	211000.0	109000.0	0.01130	0.32899
1344.5270	79.69	216000.0	89000.0	0.01197	0.16381	1426.6450	84.74	211000.0	109000.0	0.01129	0.32996
1345.7300	80.37	216000.0	90000.0	0.01198	0.16520	1427.9650	86.69	211000.0	110000.0	0.01127	0.33002
1346.8950	81.73	216000.0	90000.0	0.01197	0.16735	1429.1130	85.91	210000.0	110000.0	0.01126	0.33141
1348.2150	79.67	216000.0	89000.0	0.01198	0.17123	1430.3240	85.55	210000.0	110000.0	0.01126	0.33302
1349.4100	82.51	216000.0	88000.0	0.01198	0.17006	1431.4730	86.55	210000.0	110000.0	0.01125	0.33342
1350.5740	79.97	216000.0	90000.0	0.01197	0.16997	1432.8480	85.21	210000.0	111000.0	0.01124	0.33437
1351.7770	81.51	216000.0	92000.0	0.01197	0.17647	1434.0040	87.99	211000.0	111000.0	0.01123	0.33499
1353.0900	79.61	216000.0	91000.0	0.01196	0.18239	1435.2620	86.35	210000.0	111000.0	0.01121	0.33557
1354.2540	82.18	216000.0	91000.0	0.01196	0.18700	1436.5820	87.05	211000.0	111000.0	0.01120	0.33618
1355.4650	79.74	216000.0	91000.0	0.01195	0.18767	1437.7930	87.83	210000.0	111000.0	0.01119	0.33693
1356.7700	82.51	215000.0	92000.0	0.01195	0.19077	1438.9410	86.06	210000.0	111000.0	0.01118	0.33820
1358.0430	79.84	216000.0	92000.0	0.01195	0.19313	1440.2620	83.47	210000.0	112000.0	0.01118	0.33968
1359.1910	79.79	216000.0	93000.0	0.01194	0.19893	1441.4730	88.29	210000.0	112000.0	0.01117	0.34082
1360.5120	80.15	215000.0	92000.0	0.01193	0.20285	1442.6210	87.12	210000.0	112000.0	0.01116	0.34246
1361.7230	80.26	215000.0	92000.0	0.01193	0.20281	1443.8320	87.83	210000.0	112000.0	0.01115	0.34440
1362.8710	82.85	215000.0	92000.0	0.01193	0.20320	1445.1520	88.13	209000.0	112000.0	0.01114	0.34524
1364.0820	82.81	215000.0	92000.0	0.01193	0.20560	1446.3630	88.93	209000.0	112000.0	0.01112	0.34483
1365.4020	80.01	215000.0	93000.0	0.01193	0.20622	1447.5740	87.14	208000.0	112000.0	0.01110	0.34577
1366.5510	84.78	215000.0	95000.0	0.01192	0.21048	1448.8790	88.76	209000.0	113000.0	0.01108	0.34551
1367.6990	80.91	215000.0	94000.0	0.01191	0.21472	1450.0430	88.26	209000.0	113000.0	0.01108	0.34672
1369.0820	83.03	215000.0	94000.0	0.01191	0.21834	1451.3010	89.39	208000.0	113000.0	0.01107	0.34726
1370.2300	85.31	215000.0	94000.0	0.01191	0.21860	1452.5590	88.58	209000.0	114000.0	0.01104	0.34808
1371.4410	81.06	215000.0	94000.0	0.01192	0.21723	1453.7700	87.60	208000.0	114000.0	0.01103	0.34938
1372.7620	83.01	215000.0	95000.0	0.01190	0.22111	1454.9340	86.92	209000.0	114000.0	0.01101	0.35091
1373.9100	83.57	215000.0	98000.0	0.01189	0.22705	1456.0820	87.23	209000.0	114000.0	0.01099	0.35200
1375.1210	81.51	215000.0	97000.0	0.01186	0.23596	1457.4490	87.61	208000.0	114000.0	0.01098	0.35286
1376.3320	79.73	215000.0	98000.0	0.01185	0.23962	1458.6130	87.30	208000.0	114000.0	0.01096	0.35466
1377.6520	80.97	214000.0	96000.0	0.01184	0.24320	1459.8090	89.90	209000.0	115000.0	0.01095	0.35635

1461.1290	82.94	208000.0	115000.0	0.01093	0.35843	1544.5590	94.20	203000.0	130000.0	0.00955	0.43031
1462.2930	89.90	208000.0	115000.0	0.01092	0.35916	1545.7230	96.22	202000.0	130000.0	0.00953	0.43080
1463.4880	89.61	208000.0	115000.0	0.01091	0.35953	1546.9340	93.99	202000.0	130000.0	0.00953	0.43103
1464.6520	90.06	208000.0	115000.0	0.01089	0.36023	1548.2380	96.26	202000.0	131000.0	0.00951	0.43131
1465.9730	87.75	208000.0	116000.0	0.01087	0.36071	1549.4490	94.58	202000.0	131000.0	0.00950	0.43228
1467.1680	89.27	207000.0	115000.0	0.01085	0.36103	1550.6600	96.29	202000.0	131000.0	0.00948	0.43235
1468.3790	88.29	207000.0	116000.0	0.01084	0.36217	1552.0270	94.37	202000.0	131000.0	0.00947	0.43311
1469.6990	89.75	207000.0	116000.0	0.01082	0.36354	1553.1910	94.96	202000.0	131000.0	0.00945	0.43443
1470.9100	87.99	207000.0	117000.0	0.01080	0.36564	1554.4020	94.62	202000.0	131000.0	0.00943	0.43546
1472.0590	88.31	208000.0	117000.0	0.01078	0.36644	1555.5510	97.14	202000.0	131000.0	0.00941	0.43605
1473.3790	89.52	207000.0	117000.0	0.01075	0.36742	1556.8710	97.05	201000.0	132000.0	0.00938	0.43614
1474.5900	88.50	207000.0	117000.0	0.01073	0.36937	1558.0820	95.14	201000.0	132000.0	0.00935	0.43609
1475.8010	88.76	207000.0	118000.0	0.01071	0.37073	1559.2770	95.52	202000.0	132000.0	0.00933	0.43621
1477.0120	88.47	207000.0	119000.0	0.01069	0.37266	1560.6600	97.61	201000.0	133000.0	0.00930	0.43673
1478.3240	90.53	207000.0	119000.0	0.01066	0.37422	1561.8090	95.34	201000.0	133000.0	0.00927	0.43677
1479.4800	89.68	207000.0	119000.0	0.01065	0.37542	1563.0200	98.06	201000.0	133000.0	0.00925	0.43753
1480.6910	91.84	206000.0	119000.0	0.01063	0.37725	1564.3400	98.00	201000.0	133000.0	0.00922	0.43848
1482.0040	91.61	206000.0	120000.0	0.01059	0.37817	1565.4880	96.44	201000.0	134000.0	0.00920	0.43973
1483.1600	91.63	206000.0	120000.0	0.01056	0.37946	1566.6990	96.04	201000.0	134000.0	0.00917	0.44156
1485.6840	90.53	206000.0	121000.0	0.01052	0.38426	1567.8480	96.71	201000.0	134000.0	0.00916	0.44270
1486.8950	91.45	207000.0	121000.0	0.01050	0.38502	1569.2300	98.04	201000.0	134000.0	0.00913	0.44353
1488.0510	90.11	206000.0	121000.0	0.01048	0.38733	1570.3790	96.67	201000.0	135000.0	0.00911	0.44540
1489.1990	92.51	206000.0	121000.0	0.01046	0.38807	1571.6450	97.88	200000.0	135000.0	0.00908	0.44671
1490.5740	89.50	206000.0	122000.0	0.01044	0.38962	1572.9100	96.89	201000.0	135000.0	0.00867	0.44784
1491.7770	92.02	206000.0	122000.0	0.01042	0.39132	1574.1130	96.98	202000.0	127000.0	0.00572	0.44307
1492.9880	93.21	207000.0	123000.0	0.01039	0.39303	1575.3240	99.45	203000.0	125000.0	0.00419	0.43239
1494.3090	91.27	206000.0	122000.0	0.01036	0.39418	1576.6990	98.62	203000.0	123000.0	0.00321	0.42186
1495.5200	93.27	206000.0	123000.0	0.01034	0.39555	1577.9020	98.71	203000.0	122000.0	0.00265	0.41246
1496.6680	93.61	206000.0	123000.0	0.01032	0.39724	1579.1130	98.26	202000.0	121000.0	0.00225	0.40455
1499.1450	91.68	206000.0	124000.0	0.01027	0.39935	1580.3790	98.71	203000.0	120000.0	0.00195	0.39670
1500.2930	93.68	206000.0	124000.0	0.01025	0.40130	1581.7540	97.47	203000.0	118000.0	0.00171	0.38987
1501.5040	91.91	205000.0	124000.0	0.01022	0.40276						
1502.8240	92.58	206000.0	125000.0	0.01020	0.40284						
1503.9730	93.52	206000.0	125000.0	0.01017	0.40368						
1505.1290	91.32	205000.0	125000.0	0.01014	0.40536						
1506.5040	95.05	207000.0	126000.0	0.01011	0.40679						
1507.6520	94.80	205000.0	126000.0	0.01008	0.40933						
1508.8630	94.33	205000.0	126000.0	0.01004	0.41101						
1510.0200	93.29	204000.0	127000.0	0.01001	0.41254						
1511.3950	94.26	204000.0	127000.0	0.00997	0.41472						
1512.5430	95.23	205000.0	127000.0	0.00995	0.41518						
1513.6990	95.05	205000.0	128000.0	0.00992	0.41722						
1515.0740	94.80	204000.0	128000.0	0.00989	0.41792						
1516.2770	93.45	205000.0	128000.0	0.00987	0.41954						
1517.4880	95.07	204000.0	128000.0	0.00984	0.42107						
1518.8010	93.07	204000.0	129000.0	0.00982	0.42267						
1520.0120	95.38	204000.0	129000.0	0.00979	0.42381						
1521.1680	93.23	205000.0	129000.0	0.00977	0.42439						
1522.3710	92.78	203000.0	129000.0	0.00975	0.42600						
1523.6910	92.98	204000.0	129000.0	0.00973	0.42597						
1524.9650	94.80	204000.0	129000.0	0.00972	0.42546						
1526.1600	94.65	203000.0	129000.0	0.00970	0.42610						
1527.5430	95.36	203000.0	130000.0	0.00968	0.42634						
1528.6910	95.86	203000.0	130000.0	0.00966	0.42748						
1529.9020	96.15	203000.0	130000.0	0.00964	0.42751						
1531.2230	94.98	203000.0	130000.0	0.00963	0.42817						
1532.4340	96.17	204000.0	130000.0	0.00963	0.42821						
1533.5200	94.51	203000.0	130000.0	0.00963	0.42831						
1534.6840	95.47	204000.0	129000.0	0.00963	0.42815						
1536.0510	95.38	203000.0	130000.0	0.00962	0.42822						
1537.1990	95.92	203000.0	129000.0	0.00961	0.42833						
1538.4100	96.15	204000.0	130000.0	0.00961	0.42882						
1539.6840	93.68	203000.0	130000.0	0.00960	0.42854						
1540.8320	92.55	203000.0	130000.0	0.00959	0.42957						
1542.0430	94.36	203000.0	130000.0	0.00957	0.42992						
1543.3630	96.38	203000.0	130000.0	0.00956	0.43009						



#### 4) PN041

Time	Tts	Psg(Pa)	Pts(Pa)	Ws	Winj
1.5390	31.36	398000.0	409000.0	0.00082	0.00690
Wnat					
0.03500					
2.8590	32.59	398000.0	409000.0	0.00082	0.00690
0.03460					
4.2300	31.36	398000.0	409000.0	0.00082	0.00690
0.03470					
5.4880	31.42	398000.0	409000.0	0.00082	0.00690
0.03470					
6.9800	31.31	398000.0	409000.0	0.00082	0.00690
0.03470					
8.3010	31.33	398000.0	409000.0	0.00082	0.00690
0.03480					
9.6090	31.38	398000.0	409000.0	0.00082	0.00690
0.03490					
11.1020	31.40	398000.0	409000.0	0.00082	0.00690
0.03500					
12.4690	31.33	398000.0	409000.0	0.00082	0.00690
0.03490					
13.7300	31.42	398000.0	409000.0	0.00082	0.00690
0.03500					
15.2700	31.38	398000.0	403000.0	0.00083	0.00770
0.03780					
16.5900	31.49	395000.0	332000.0	0.00095	0.27790
0.20700					
17.9100	31.42	393000.0	302000.0	0.00105	0.46170
0.28320					
19.1680	31.31	393000.0	299000.0	0.00116	0.57720
0.24470					
20.5390	31.71	393000.0	290000.0	0.00131	0.66670
0.22270					
21.8090	32.15	393000.0	295000.0	0.00146	0.71900
0.21600					
23.1290	32.92	392000.0	253000.0	0.00179	0.74670
0.21250					
24.6090	33.87	391000.0	203000.0	0.00269	0.72930
0.20230					
25.8710	34.65	391000.0	184000.0	0.00333	0.69530
0.19940					
27.1290	35.16	391000.0	172000.0	0.00383	0.66040
0.19090					
28.6210	35.66	391000.0	165000.0	0.00531	0.62460
0.18610					
29.9410	36.04	390000.0	163000.0	0.00698	0.59760
0.19060					
31.2500	36.35	390000.0	161000.0	0.00843	0.57580
0.19430					
32.6800	36.55	390000.0	159000.0	0.00977	0.55830
0.19370					
34.0000	39.45	389000.0	158000.0	0.01068	0.54640
0.19080					
35.3200	36.66	389000.0	157000.0	0.01136	0.53610
0.19550					
36.5780	36.72	389000.0	158000.0	0.01185	0.52940
0.19980					
38.0080	36.79	388000.0	158000.0	0.01226	0.52350
0.20870					
39.3280	36.94	388000.0	157000.0	0.01250	0.52140
0.20700					
40.6990	37.39	388000.0	158000.0	0.01267	0.51880
0.21520					
42.1290	37.72	387000.0	156000.0	0.01282	0.51660

0.21360					
43.3910	37.92	387000.0	157000.0	0.01291	0.51350
0.21990					
44.6600	38.34	387000.0	156000.0	0.01299	0.51180
0.21940					
46.1410	38.76	386000.0	156000.0	0.01304	0.50960
0.21690					
47.4610	39.00	386000.0	156000.0	0.01307	0.50970
0.22410					
48.6680	39.18	386000.0	156000.0	0.01311	0.50910
0.22480					
49.9800	39.47	385000.0	157000.0	0.01313	0.50920
0.22440					
51.4100	39.69	385000.0	155000.0	0.01314	0.50750
0.23910					
52.7300	39.82	385000.0	155000.0	0.01315	0.50690
0.23560					
53.9880	40.11	385000.0	155000.0	0.01316	0.50670
0.24390					
55.4800	40.33	384000.0	155000.0	0.01318	0.50680
0.24470					
56.7890	40.48	384000.0	154000.0	0.01318	0.50590
0.25160					
58.1090	40.73	384000.0	154000.0	0.01319	0.50500
0.25870					
59.6020	40.97	383000.0	155000.0	0.01320	0.50560
0.25760					
60.9100	41.24	383000.0	155000.0	0.01320	0.50500
0.26080					
62.2300	41.41	382000.0	153000.0	0.01320	0.50370
0.26260					
63.6600	41.66	382000.0	153000.0	0.01322	0.50330
0.27460					
64.9180	41.79	382000.0	153000.0	0.01324	0.50160
0.27970					
66.2380	42.14	382000.0	153000.0	0.01323	0.49950
0.27990					
67.5590	42.43	382000.0	153000.0	0.01325	0.49900
0.27530					
68.9880	42.76	382000.0	152000.0	0.01326	0.49940
0.27190					
70.3090	43.12	381000.0	153000.0	0.01328	0.49870
0.27110					
71.5700	43.29	381000.0	152000.0	0.01329	0.49850
0.27270					
73.0510	43.63	380000.0	151000.0	0.01330	0.49880
0.27780					
74.3200	43.69	380000.0	152000.0	0.01331	0.49760
0.28050					
75.6290	43.89	380000.0	152000.0	0.01332	0.49580
0.28070					
77.1210	44.31	380000.0	153000.0	0.01333	0.49710
0.28380					
78.3790	44.42	380000.0	152000.0	0.01335	0.49740
0.27810					
79.6990	44.64	380000.0	151000.0	0.01336	0.49770
0.28830					
80.9610	44.91	379000.0	152000.0	0.01337	0.49810
0.29440					
82.4410	45.28	379000.0	152000.0	0.01337	0.49850
0.28400					
83.7580	45.37	379000.0	152000.0	0.01338	0.49900
0.29190					
85.0780	45.66	378000.0	153000.0	0.01340	0.49850
0.28900					
86.5590	46.01	378000.0	152000.0	0.01341	0.49790

0.28270												
87.8280	46.32	377000.0	152000.0	0.01342	0.49790							
0.28680												
89.1480	51.04	377000.0	152000.0	0.01343	0.49780							
0.30010												
90.6290	46.92	377000.0	153000.0	0.01345	0.49800							
0.30840												
91.9490	47.08	377000.0	151000.0	0.01346	0.49660							
0.31360												
93.2700	47.30	376000.0	152000.0	0.01348	0.49600							
0.31130												
94.6910	47.70	376000.0	152000.0	0.01349	0.49600							
0.30950												
96.0080	47.96	376000.0	151000.0	0.01350	0.49500							
0.31510												
97.3280	48.25	375000.0	153000.0	0.01350	0.49370							
0.31400												
98.6480	48.54	375000.0	151000.0	0.01352	0.49440							
0.32190												
100.1290	48.74	375000.0	151000.0	0.01353	0.49320							
0.32200												
101.3910	48.78	375000.0	152000.0	0.01354	0.49320							
0.32020												
102.7110	49.05	375000.0	152000.0	0.01355	0.49390							
0.32440												
104.1990	49.40	374000.0	151000.0	0.01355	0.49390							
0.31890												
105.5080	49.62	374000.0	154000.0	0.01356	0.49520							
0.32270												
106.8280	54.03	374000.0	150000.0	0.01357	0.49450							
0.32400												
108.2580	50.15	373000.0	151000.0	0.01358	0.49350							
0.33150												
109.5780	50.48	373000.0	150000.0	0.01359	0.49320							
0.32880												
110.8980	50.79	373000.0	151000.0	0.01359	0.49180							
0.32860												
112.1600	50.99	372000.0	151000.0	0.01360	0.49150							
0.33310												
113.6410	51.12	372000.0	150000.0	0.01360	0.49160							
0.33060												
114.9610	51.43	372000.0	149000.0	0.01361	0.49170							
0.32970												
116.2810	51.70	372000.0	151000.0	0.01363	0.49130							
0.33080												
117.7580	51.81	372000.0	152000.0	0.01364	0.49050							
0.33300												
119.0780	52.08	371000.0	152000.0	0.01364	0.49080							
0.33310												
120.3980	52.28	371000.0	151000.0	0.01364	0.49170							
0.33200												
121.8790	52.61	370000.0	151000.0	0.01364	0.49220							
0.33290												
123.1410	52.74	370000.0	152000.0	0.01365	0.49140							
0.33090												
124.4610	53.01	370000.0	150000.0	0.01366	0.49120							
0.32060												
125.8910	53.06	369000.0	151000.0	0.01368	0.49060							
0.32600												
127.2110	53.30	369000.0	149000.0	0.01368	0.48890							
0.32710												
128.5310	53.45	369000.0	152000.0	0.01369	0.48920							
0.32110												
129.8520	53.66	368000.0	152000.0	0.01370	0.48910							
0.32760												
131.3280	53.92	368000.0	153000.0	0.01369	0.48920							

0.33150												
132.5900	54.30	368000.0	149000.0	0.01371	0.49020							
0.34180												
133.9100	54.50	368000.0	152000.0	0.01370	0.49100							
0.33350												
135.3910	54.72	367000.0	153000.0	0.01371	0.49110							
0.32230												
136.6600	55.14	367000.0	153000.0	0.01372	0.49210							
0.32190												
137.9180	55.41	367000.0	150000.0	0.01371	0.49130							
0.31760												
139.3980	56.10	367000.0	150000.0	0.01373	0.49070							
0.31370												
140.7810	55.94	366000.0	152000.0	0.01374	0.49040							
0.29820												
142.0900	56.25	366000.0	151000.0	0.01375	0.49040							
0.28410												
143.4100	56.59	366000.0	151000.0	0.01375	0.49010							
0.28330												
144.8980	56.94	366000.0	150000.0	0.01375	0.48970							
0.29170												
146.2110	57.37	366000.0	152000.0	0.01376	0.48920							
0.29930												
147.5310	57.54	365000.0	152000.0	0.01376	0.48870							
0.29170												
148.9610	57.72	365000.0	152000.0	0.01377	0.49020							
0.29690												
150.2810	57.88	365000.0	151000.0	0.01377	0.49090							
0.29480												
151.6020	57.97	365000.0	154000.0	0.01377	0.49130							
0.30320												
153.0200	58.06	364000.0	151000.0	0.01379	0.49160							
0.29760												
154.3400	58.26	364000.0	149000.0	0.01379	0.49160							
0.29510												
155.6600	57.70	364000.0	151000.0	0.01380	0.49080							
0.30410												
157.0900	58.84	364000.0	153000.0	0.01381	0.49000							
0.30520												
158.4100	58.95	364000.0	150000.0	0.01382	0.48870							
0.30780												
159.6680	59.26	363000.0	148000.0	0.01384	0.48920							
0.31170												
161.0390	59.44	363000.0	150000.0	0.01384	0.48820							
0.29830												
162.5310	59.64	362000.0	150000.0	0.01386	0.48730							
0.30580												
163.8400	59.97	362000.0	149000.0	0.01387	0.48460							
0.30680												
165.1600	60.06	362000.0	151000.0	0.01389	0.48430							
0.30730												
166.6480	60.51	361000.0	148000.0	0.01389	0.48320							
0.30570												
167.9610	60.57	361000.0	149000.0	0.01389	0.48280							
0.30200												
169.2300	60.68	360000.0	150000.0	0.01390	0.48180							
0.30540												
170.7110	60.91	360000.0	150000.0	0.01391	0.48130							
0.30950												
172.0310	61.06	360000.0	150000.0	0.01393	0.48080							
0.30900												
173.2890	62.82	360000.0	150000.0	0.01395	0.48020							
0.31270												
174.6090	61.42	359000.0	148000.0	0.01395	0.47920							
0.31480												
176.0390	61.66	359000.0	148000.0	0.01396	0.47910							

0. 31870					
177. 4100	61. 97	359000. 0	148000. 0	0. 01396	0. 48030
0. 32160					
178. 7300	62. 22	359000. 0	150000. 0	0. 01397	0. 47870
0. 31580					
180. 1600	62. 35	359000. 0	147000. 0	0. 01398	0. 47770
0. 31870					
181. 4800	62. 53	358000. 0	150000. 0	0. 01399	0. 47740
0. 30830					
182. 7890	62. 64	358000. 0	150000. 0	0. 01399	0. 47650
0. 31080					
184. 2190	63. 00	358000. 0	148000. 0	0. 01399	0. 47650
0. 31440					
185. 4300	63. 27	357000. 0	148000. 0	0. 01399	0. 47680
0. 30740					
186. 7500	63. 47	358000. 0	151000. 0	0. 01400	0. 47690
0. 32020					
188. 2300	63. 82	357000. 0	148000. 0	0. 01400	0. 47720
0. 32240					
189. 5510	63. 84	357000. 0	151000. 0	0. 01401	0. 47750
0. 31980					
190. 8710	64. 18	356000. 0	154000. 0	0. 01402	0. 47780
0. 32790					
192. 1910	64. 38	356000. 0	151000. 0	0. 01402	0. 47860
0. 32440					
193. 6680	64. 53	356000. 0	149000. 0	0. 01402	0. 47840
0. 31780					
195. 0390	64. 91	356000. 0	148000. 0	0. 01404	0. 47780
0. 31650					
196. 3090	65. 18	355000. 0	150000. 0	0. 01405	0. 47770
0. 31210					
197. 7890	65. 45	355000. 0	148000. 0	0. 01404	0. 47820
0. 31330					
199. 0510	65. 34	355000. 0	147000. 0	0. 01404	0. 47780
0. 31600					
200. 3710	65. 83	355000. 0	148000. 0	0. 01404	0. 47690
0. 31480					
201. 8520	66. 05	354000. 0	147000. 0	0. 01404	0. 47810
0. 32430					
203. 1210	66. 25	354000. 0	149000. 0	0. 01405	0. 47760
0. 33020					
204. 4300	66. 76	354000. 0	149000. 0	0. 01405	0. 47780
0. 32470					
205. 8590	66. 50	354000. 0	146000. 0	0. 01406	0. 47690
0. 31950					
207. 1800	66. 83	353000. 0	150000. 0	0. 01406	0. 47660
0. 31790					
208. 5000	67. 03	353000. 0	151000. 0	0. 01406	0. 47660
0. 31030					
209. 8200	67. 16	353000. 0	149000. 0	0. 01407	0. 47660
0. 31230					
211. 3010	67. 39	352000. 0	149000. 0	0. 01406	0. 47690
0. 31210					
212. 5590	67. 56	352000. 0	149000. 0	0. 01407	0. 47600
0. 31050					
213. 8790	67. 83	352000. 0	148000. 0	0. 01407	0. 47630
0. 31370					
215. 3590	67. 99	351000. 0	148000. 0	0. 01406	0. 47590
0. 32110					
216. 6290	68. 14	351000. 0	146000. 0	0. 01407	0. 47630
0. 32460					
217. 8910	68. 39	351000. 0	149000. 0	0. 01407	0. 47630
0. 31710					
219. 3710	68. 63	351000. 0	149000. 0	0. 01409	0. 47800
0. 31920					
220. 6910	68. 76	350000. 0	148000. 0	0. 01410	0. 47870

0. 32410					
222. 0080	69. 01	350000. 0	148000. 0	0. 01410	0. 47820
0. 32270					
223. 3280	69. 41	350000. 0	149000. 0	0. 01411	0. 47700
0. 32070					
224. 8090	69. 52	350000. 0	150000. 0	0. 01412	0. 47720
0. 32130					
226. 1290	69. 63	349000. 0	151000. 0	0. 01411	0. 47630
0. 32490					
227. 4490	69. 94	349000. 0	149000. 0	0. 01411	0. 47650
0. 32220					
228. 9300	70. 19	349000. 0	149000. 0	0. 01410	0. 47580
0. 32650					
230. 1910	70. 50	348000. 0	151000. 0	0. 01410	0. 47460
0. 32890					
231. 5080	70. 79	348000. 0	147000. 0	0. 01413	0. 47550
0. 32470					
233. 0000	70. 94	348000. 0	151000. 0	0. 01413	0. 47500
0. 32300					
234. 2580	71. 12	348000. 0	149000. 0	0. 01412	0. 47560
0. 32000					
235. 5780	71. 30	348000. 0	152000. 0	0. 01411	0. 47540
0. 32430					
237. 0590	71. 50	347000. 0	150000. 0	0. 01413	0. 47460
0. 32790					
238. 3790	71. 68	347000. 0	149000. 0	0. 01415	0. 47420
0. 33370					
239. 7500	71. 90	347000. 0	149000. 0	0. 01415	0. 47350
0. 32830					
241. 0080	72. 02	347000. 0	150000. 0	0. 01416	0. 47330
0. 33330					
242. 4410	72. 13	346000. 0	151000. 0	0. 01416	0. 47280
0. 33100					
243. 7580	72. 37	346000. 0	149000. 0	0. 01414	0. 47190
0. 33050					
245. 0780	71. 77	345000. 0	148000. 0	0. 01414	0. 47250
0. 33370					
246. 5080	72. 68	345000. 0	149000. 0	0. 01414	0. 47180
0. 34080					
247. 8280	72. 93	345000. 0	148000. 0	0. 01414	0. 47190
0. 33680					
249. 1410	73. 15	345000. 0	147000. 0	0. 01415	0. 47180
0. 33890					
250. 5700	73. 29	344000. 0	147000. 0	0. 01415	0. 47150
0. 32930					
251. 8910	73. 40	344000. 0	147000. 0	0. 01417	0. 47150
0. 32830					
253. 2110	73. 49	344000. 0	147000. 0	0. 01417	0. 47180
0. 32500					
254. 5310	73. 60	344000. 0	149000. 0	0. 01418	0. 47180
0. 33320					
256. 0080	74. 02	343000. 0	147000. 0	0. 01417	0. 47110
0. 32940					
257. 3280	73. 93	343000. 0	149000. 0	0. 01418	0. 47070
0. 31960					
258. 6480	74. 00	343000. 0	147000. 0	0. 01417	0. 47130
0. 32100					
260. 0700	74. 11	343000. 0	147000. 0	0. 01417	0. 46990
0. 32480					
261. 3910	74. 31	342000. 0	145000. 0	0. 01416	0. 46970
0. 32900					
262. 7110	74. 54	342000. 0	144000. 0	0. 01417	0. 46830
0. 33060					
264. 1410	72. 15	342000. 0	147000. 0	0. 01417	0. 46670
0. 32500					
265. 4610	74. 67	342000. 0	146000. 0	0. 01417	0. 46700

0.33520											
266.7190	74.76	342000.0	148000.0	0.01417	0.46680						
0.33370											
268.1480	74.92	341000.0	152000.0	0.01417	0.46710						
0.33180											
269.4100	75.07	341000.0	148000.0	0.01418	0.46870						
0.33930											
270.7300	75.43	340000.0	150000.0	0.01418	0.46910						
0.33280											
272.0510	75.52	340000.0	147000.0	0.01418	0.46840						
0.32850											
273.4800	75.70	340000.0	148000.0	0.01418	0.46800						
0.31880											
274.7380	75.81	340000.0	146000.0	0.01418	0.46760						
0.32020											
276.0000	75.95	339000.0	147000.0	0.01417	0.46700						
0.31970											
277.4880	76.17	339000.0	149000.0	0.01416	0.46680						
0.31910											
278.8590	76.15	339000.0	142000.0	0.01417	0.46690						
0.32820											
280.1210	76.42	339000.0	148000.0	0.01418	0.46770						
0.32680											
281.6020	76.53	339000.0	147000.0	0.01417	0.46800						
0.32890											
282.8710	76.62	338000.0	148000.0	0.01418	0.46720						
0.32720											
284.1910	76.84	338000.0	146000.0	0.01419	0.46590						
0.32920											
285.5000	76.86	338000.0	146000.0	0.01420	0.46460						
0.32640											
286.9880	77.18	337000.0	147000.0	0.01420	0.46460						
0.32930											
288.2500	77.40	337000.0	150000.0	0.01419	0.46380						
0.33180											
289.5700	77.60	337000.0	145000.0	0.01418	0.46410						
0.32900											
291.0510	77.67	336000.0	144000.0	0.01419	0.46380						
0.32350											
292.3710	77.78	336000.0	143000.0	0.01419	0.46270						
0.32110											
293.6910	77.85	336000.0	141000.0	0.01419	0.46180						
0.33060											
295.1680	77.85	336000.0	142000.0	0.01420	0.46140						
0.32110											
296.4300	77.98	335000.0	153000.0	0.01420	0.46160						
0.31810											
297.7500	78.16	335000.0	150000.0	0.01420	0.46110						
0.33000											
299.1800	78.30	334000.0	150000.0	0.01421	0.45970						
0.32480											
300.5000	78.41	334000.0	146000.0	0.01421	0.45880						
0.32240											
301.8200	78.63	334000.0	148000.0	0.01419	0.45820						
0.32780											
303.1410	78.77	334000.0	145000.0	0.01420	0.45740						
0.33330											
304.6210	78.97	333000.0	147000.0	0.01421	0.45640						
0.33050											
305.8790	79.08	333000.0	143000.0	0.01421	0.45550						
0.33040											
307.1990	79.24	333000.0	142000.0	0.01421	0.45560						
0.32290											
308.6290	79.49	332000.0	144000.0	0.01420	0.45550						
0.31990											
309.9490	79.60	332000.0	146000.0	0.01420	0.45650						

0.33380											
311.2110	79.84	332000.0	145000.0	0.01421	0.45700						
0.33340											
312.6910	79.84	332000.0	151000.0	0.01421	0.45870						
0.33500											
314.0700	80.09	332000.0	143000.0	0.01422	0.45740						
0.33180											
315.3280	80.16	332000.0	145000.0	0.01422	0.45720						
0.32640											
316.6990	80.34	331000.0	147000.0	0.01422	0.45780						
0.32030											
318.1290	80.41	331000.0	145000.0	0.01420	0.45710						
0.32580											
319.4490	80.50	331000.0	144000.0	0.01421	0.45670						
0.32560											
320.7110	80.65	330000.0	144000.0	0.01421	0.45700						
0.32290											
322.1910	80.79	330000.0	146000.0	0.01420	0.45760						
0.32530											
323.5080	81.05	330000.0	150000.0	0.01420	0.45780						
0.32620											
324.8280	81.14	329000.0	146000.0	0.01420	0.45840						
0.32540											
326.3090	81.46	329000.0	145000.0	0.01421	0.45780						
0.33460											
327.5780	81.01	329000.0	146000.0	0.01420	0.45740						
0.33120											
328.8980	81.75	329000.0	149000.0	0.01420	0.45790						
0.33310											
330.3200	81.82	329000.0	150000.0	0.01420	0.45680						
0.32170											
331.6410	81.95	328000.0	141000.0	0.01420	0.45710						
0.32760											
332.9610	82.11	328000.0	143000.0	0.01421	0.45740						
0.33490											
334.2810	82.22	328000.0	148000.0	0.01421	0.45630						
0.33830											
335.7580	82.69	327000.0	146000.0	0.01421	0.45610						
0.32460											
337.0200	85.09	327000.0	142000.0	0.01421	0.45620						
0.32700											
338.3400	82.64	327000.0	147000.0	0.01422	0.45460						
0.32510											
339.8280	82.94	327000.0	143000.0	0.01421	0.45430						
0.32100											
341.0900	82.94	326000.0	143000.0	0.01420	0.45320						
0.31810											
342.3520	83.14	326000.0	139000.0	0.01420	0.45370						
0.32420											
343.8400	83.25	326000.0	146000.0	0.01420	0.45240						
0.32710											
345.2110	83.47	326000.0	152000.0	0.01420	0.45180						
0.32760											
346.4690	83.63	325000.0	143000.0	0.01421	0.45310						
0.32100											
347.8400	84.01	325000.0	144000.0	0.01421	0.45380						
0.32730											
349.3280	83.99	325000.0	145000.0	0.01421	0.45430						
0.32620											
350.5900	84.15	324000.0	144000.0	0.01421	0.45430						
0.32910											
351.8520	84.35	324000.0	148000.0	0.01419	0.45780						
0.32320											
353.3400	84.46	324000.0	141000.0	0.01419	0.45850						
0.32840											
354.6600	84.64	323000.0	140000.0	0.01419	0.45940						



0.33230						
355.9690	84.84	323000.0	152000.0	0.01419	0.45700	
0.33040						
357.3980	84.82	323000.0	147000.0	0.01418	0.45640	
0.32710						
358.7190	85.02	323000.0	143000.0	0.01419	0.45710	
0.32400						
360.0390	85.04	323000.0	145000.0	0.01418	0.45450	
0.32340						
361.4690	85.40	322000.0	140000.0	0.01419	0.45270	
0.31230						
362.7810	85.36	322000.0	148000.0	0.01418	0.45460	
0.31380						
364.0510	85.67	322000.0	150000.0	0.01418	0.45390	
0.31280						
365.3710	85.80	321000.0	141000.0	0.01420	0.45300	
0.32190						
366.7890	85.96	321000.0	144000.0	0.01419	0.45390	
0.31500						
368.1090	86.05	321000.0	149000.0	0.01419	0.45370	
0.31550						
369.4300	86.34	321000.0	141000.0	0.01420	0.45540	
0.31730						
370.9100	86.70	320000.0	145000.0	0.01419	0.45670	
0.31360						
372.2300	87.01	320000.0	138000.0	0.01420	0.45490	
0.32330						
373.5510	87.26	320000.0	142000.0	0.01420	0.45350	
0.32500						
374.9800	87.51	320000.0	140000.0	0.01419	0.45370	
0.32380						
376.3010	87.66	319000.0	140000.0	0.01419	0.45210	
0.32790						
377.6090	87.84	319000.0	139000.0	0.01418	0.45260	
0.32550						
379.0390	88.13	319000.0	137000.0	0.01419	0.45180	
0.32570						
380.3590	88.33	318000.0	139000.0	0.01419	0.45150	
0.31960						
381.6800	88.65	318000.0	143000.0	0.01419	0.45280	
0.31780						
382.9410	88.81	318000.0	143000.0	0.01418	0.45080	
0.32050						
384.4300	88.94	318000.0	136000.0	0.01419	0.44820	
0.31320						
385.7380	89.05	318000.0	137000.0	0.01420	0.44710	
0.31920						
387.0590	89.05	317000.0	151000.0	0.01419	0.44900	
0.32030						
388.5390	89.34	317000.0	143000.0	0.01419	0.44980	
0.32620						
389.8090	89.43	317000.0	138000.0	0.01420	0.44710	
0.32520						
391.1290	90.06	316000.0	146000.0	0.01419	0.44500	
0.31910						
392.6090	89.54	316000.0	142000.0	0.01418	0.44660	
0.32090						
393.9300	89.61	316000.0	140000.0	0.01418	0.44510	
0.31950						
395.2500	89.63	316000.0	140000.0	0.01418	0.44490	
0.32010						
396.5080	89.68	315000.0	145000.0	0.01419	0.44510	
0.32180						
397.9880	89.77	315000.0	146000.0	0.01418	0.44730	
0.33180						
399.3090	89.88	315000.0	139000.0	0.01417	0.44840	

0.33460						
400.6290	89.90	315000.0	146000.0	0.01418	0.44700	
0.34100						
402.1090	86.22	314000.0	142000.0	0.01418	0.44620	
0.34340						
403.4300	90.19	314000.0	141000.0	0.01417	0.44680	
0.33220						
404.7500	90.28	314000.0	140000.0	0.01418	0.44540	
0.33630						
406.1800	90.57	314000.0	142000.0	0.01419	0.44270	
0.33310						
407.4880	90.75	314000.0	147000.0	0.01418	0.44640	
0.33260						
408.8090	90.87	313000.0	140000.0	0.01418	0.44620	
0.33560						
410.2380	91.20	313000.0	142000.0	0.01418	0.44760	
0.33430						
411.5590	91.36	313000.0	143000.0	0.01417	0.44870	
0.34590						
412.8200	91.60	313000.0	146000.0	0.01416	0.44940	
0.33860						
414.1910	91.92	312000.0	138000.0	0.01415	0.44920	
0.33530						
415.6210	92.01	312000.0	143000.0	0.01417	0.44700	
0.32690						
417.0000	92.26	312000.0	145000.0	0.01416	0.44850	
0.33410						
418.3090	92.30	311000.0	146000.0	0.01416	0.45060	
0.32960						
419.7380	92.48	311000.0	140000.0	0.01415	0.45060	
0.33250						
421.0590	92.66	311000.0	137000.0	0.01415	0.45080	
0.33460						
422.3200	93.00	311000.0	145000.0	0.01414	0.45050	
0.33810						
423.8090	93.13	311000.0	144000.0	0.01414	0.45040	
0.33720						
425.0700	93.24	310000.0	143000.0	0.01414	0.45090	
0.33480						
426.3910	93.40	310000.0	142000.0	0.01414	0.45040	
0.32820						
427.6480	93.47	310000.0	143000.0	0.01415	0.44890	
0.32840						
429.1290	93.56	310000.0	139000.0	0.01415	0.44930	
0.33120						
430.4490	93.67	309000.0	138000.0	0.01416	0.44850	
0.32380						
431.7190	93.71	309000.0	143000.0	0.01414	0.44720	
0.32760						
433.0900	93.83	309000.0	141000.0	0.01413	0.44740	
0.33130						
434.4100	93.92	308000.0	139000.0	0.01413	0.44910	
0.32390						
435.7300	93.98	308000.0	141000.0	0.01412	0.45090	
0.31840						
437.1480	94.10	308000.0	143000.0	0.01412	0.45020	
0.31590						
438.4690	94.28	308000.0	142000.0	0.01414	0.45110	
0.31640						
439.7890	94.30	308000.0	137000.0	0.01413	0.45030	
0.32400						
441.2190	94.41	307000.0	143000.0	0.01413	0.44970	
0.32510						
442.4800	94.26	307000.0	145000.0	0.01411	0.45170	
0.32770						
443.7380	94.48	307000.0	140000.0	0.01410	0.45420	

0.32550											
445.0590	94.46	307000.0	145000.0	0.01411	0.45420						
0.32890											
446.5510	94.59	306000.0	144000.0	0.01412	0.45330						
0.32930											
447.8090	94.66	306000.0	138000.0	0.01412	0.45300						
0.33180											
449.1290	94.61	305000.0	138000.0	0.01412	0.45370						
0.33440											
450.5590	94.57	304000.0	149000.0	0.01411	0.45370						
0.33580											
451.8710	94.84	303000.0	138000.0	0.01410	0.45480						
0.34010											
453.1910	94.90	302000.0	147000.0	0.01409	0.45480						
0.33470											
454.6210	94.95	302000.0	136000.0	0.01409	0.45330						
0.34540											
455.9410	95.02	301000.0	139000.0	0.01407	0.45440						
0.35250											
457.2580	95.10	300000.0	141000.0	0.01405	0.45370						
0.35670											
458.5200	95.22	300000.0	140000.0	0.01407	0.45180						
0.36740											
460.0000	95.33	300000.0	148000.0	0.01407	0.45030						
0.38080											
461.3200	95.47	300000.0	141000.0	0.01407	0.45080						
0.38170											
462.6410	95.44	299000.0	134000.0	0.01408	0.44730						
0.38190											
464.1210	95.51	299000.0	136000.0	0.01409	0.44380						
0.38580											
465.3910	95.69	298000.0	143000.0	0.01410	0.44440						
0.39310											
466.6480	95.80	298000.0	144000.0	0.01409	0.44350						
0.40310											
468.1290	95.94	298000.0	133000.0	0.01408	0.44520						
0.41310											
469.3910	96.12	297000.0	133000.0	0.01408	0.44420						
0.41700											
470.7110	96.21	297000.0	136000.0	0.01408	0.44570						
0.42030											
472.1990	96.37	297000.0	136000.0	0.01408	0.44380						
0.42920											
473.5080	96.55	296000.0	133000.0	0.01408	0.44240						
0.44300											
474.8280	96.66	296000.0	138000.0	0.01410	0.44060						
0.44080											
476.1480	96.73	296000.0	135000.0	0.01410	0.43980						
0.44600											
477.6290	96.89	295000.0	137000.0	0.01409	0.44030						
0.46030											
478.8980	96.97	295000.0	139000.0	0.01410	0.43760						
0.45730											
480.1600	97.09	295000.0	137000.0	0.01410	0.43620						
0.44760											
481.6410	97.06	294000.0	138000.0	0.01410	0.43830						
0.44090											
482.9610	97.09	294000.0	142000.0	0.01409	0.44100						
0.45150											
484.2810	97.02	293000.0	143000.0	0.01405	0.44750						
0.43810											
485.7580	97.02	293000.0	147000.0	0.01398	0.45630						
0.46180											
487.0310	96.97	293000.0	151000.0	0.01391	0.46390						
0.45780											
488.3400	97.02	292000.0	149000.0	0.01386	0.47040						

0.46460											
489.6600	97.20	292000.0	152000.0	0.01380	0.47630						
0.45160											
491.1480	97.16	292000.0	155000.0	0.01372	0.48250						
0.44630											
492.4610	97.22	291000.0	157000.0	0.01363	0.48870						
0.44730											
493.7300	97.36	291000.0	158000.0	0.01354	0.49550						
0.44440											
495.2110	97.47	291000.0	160000.0	0.01345	0.50240						
0.43520											
496.5310	97.52	291000.0	167000.0	0.01331	0.51110						
0.43940											
497.8520	97.63	290000.0	166000.0	0.01318	0.51860						
0.43590											
499.3280	97.81	290000.0	168000.0	0.01304	0.52570						
0.44110											
500.5900	97.90	290000.0	168000.0	0.01295	0.53120						
0.43240											
501.9100	97.85	289000.0	172000.0	0.01282	0.53690						
0.43440											
503.3400	98.08	289000.0	176000.0	0.01266	0.54520						
0.42430											
504.6600	98.17	289000.0	175000.0	0.01252	0.55080						
0.42500											
505.9800	98.26	288000.0	178000.0	0.01238	0.55710						
0.41680											
507.2380	98.26	288000.0	181000.0	0.01219	0.56400						
0.41190											
508.6680	98.56	287000.0	182000.0	0.01199	0.57290						
0.40120											
509.9800	98.76	288000.0	184000.0	0.01185	0.57930						
0.40340											
511.2500	98.91	287000.0	185000.0	0.01170	0.58480						
0.40510											
512.6800	99.05	286000.0	187000.0	0.01154	0.59040						
0.40790											
513.9880	99.37	287000.0	188000.0	0.01142	0.59470						
0.40740											
515.3090	99.50	286000.0	188000.0	0.01133	0.59830						
0.40290											
516.7380	99.61	286000.0	191000.0	0.01117	0.60350						
0.40120											
518.0000	99.73	285000.0	195000.0	0.01098	0.60920						
0.39480											
519.3200	100.09	285000.0	194000.0	0.01083	0.61370						
0.38330											
520.6990	100.38	285000.0	198000.0	0.01068	0.61910						
0.37990											
522.1800	100.58	284000.0	199000.0	0.01047	0.62540						
0.37760											
523.4410	100.74	284000.0	198000.0	0.01034	0.63020						
0.37810											
524.6990	100.97	283000.0	202000.0	0.01021	0.63520						
0.36820											
526.1910	101.28	284000.0	203000.0	0.01005	0.63900						
0.36180											
527.4490	101.39	283000.0	205000.0	0.00985	0.64550						
0.35580											
528.7700	101.55	282000.0	206000.0	0.00967	0.65010						
0.35180											
530.2500	101.94	282000.0	208000.0	0.00949	0.65470						
0.35050											
531.5700	102.12	282000.0	211000.0	0.00933	0.66090						
0.34010											
532.8910	102.32	282000.0	213000.0	0.00916	0.66550						

0.33270						
534.3200	102.70	281000.0	214000.0	0.00894	0.67110	
0.32920						
535.6290	103.02	281000.0	216000.0	0.00877	0.67430	
0.32830						
536.9490	103.27	281000.0	217000.0	0.00860	0.67910	
0.32600						
538.2700	103.56	280000.0	219000.0	0.00841	0.68500	
0.31980						
539.7500	103.74	280000.0	221000.0	0.00820	0.68990	
0.31160						
541.0700	104.01	279000.0	223000.0	0.00801	0.69610	
0.30270						
542.3910	104.26	279000.0	225000.0	0.00784	0.69930	
0.30410						
543.8200	104.60	279000.0	229000.0	0.00764	0.70450	
0.28770						
545.1410	104.78	279000.0	231000.0	0.00744	0.71020	
0.27940						
546.4610	105.03	278000.0	232000.0	0.00722	0.71790	
0.27460						
547.8790	105.28	278000.0	234000.0	0.00704	0.72250	
0.26960						
549.1990	105.44	277000.0	236000.0	0.00686	0.72770	
0.26410						
550.5200	105.64	277000.0	237000.0	0.00670	0.73120	
0.25970						
551.9490	105.93	278000.0	238000.0	0.00655	0.73530	
0.25700						
553.2700	106.07	277000.0	240000.0	0.00640	0.73890	
0.24710						
554.5780	106.36	277000.0	243000.0	0.00624	0.74230	
0.23710						
555.8980	106.66	276000.0	245000.0	0.00605	0.74780	
0.22300						
557.3910	106.95	277000.0	246000.0	0.00586	0.75330	
0.21690						
558.6480	107.18	276000.0	248000.0	0.00571	0.75870	
0.21440						
559.9690	107.42	276000.0	249000.0	0.00557	0.76190	
0.20400						
561.3980	107.63	276000.0	249000.0	0.00543	0.76580	
0.20530						
562.6600	107.92	275000.0	251000.0	0.00531	0.76920	
0.20270						
563.9800	108.08	275000.0	252000.0	0.00519	0.77260	
0.20160						
565.4610	108.40	275000.0	253000.0	0.00506	0.77580	
0.19230						
566.7190	108.71	275000.0	254000.0	0.00494	0.77850	
0.18160						
568.0390	108.81	274000.0	255000.0	0.00485	0.78020	
0.18140						
569.3590	109.03	274000.0	255000.0	0.00474	0.78210	
0.17300						
570.7890	109.21	274000.0	257000.0	0.00462	0.78710	
0.16000						
572.1090	109.39	274000.0	259000.0	0.00452	0.78940	
0.15280						
573.4180	109.71	273000.0	258000.0	0.00441	0.79270	
0.15170						

**BIBLIOGRAPHIC DATA SHEET**

(See instructions on the reverse)

1. REPORT NUMBER  
(Assigned by NRC. Add Vol., Supp., Rev.,  
and Addendum Numbers, if any.)

NUREG/IA-0134  
CAMP005

2. TITLE AND SUBTITLE

Assessment of RELAP5/MOD3.1 for Gravity-Driven Injection Experiment in the Core Makeup Tank of the CARR Passive Reactor (CP-1300)

3. DATE REPORT PUBLISHED

MONTH	YEAR
October	1996

4. FIN OR GRANT NUMBER

W6238

5. AUTHOR(S)

Sang Il Lee, Hee Cheon No/KAIST  
Young Seok Bang, Hho Jung Kim/KINS

6. TYPE OF REPORT

Technical

7. PERIOD COVERED (Inclusive Dates)

8. PERFORMING ORGANIZATION - NAME AND ADDRESS (If NRC, provide Division, Office or Region, U.S. Nuclear Regulatory Commission, and mailing address; if contractor, provide name and mailing address.)

Korea Advanced Institute of Science and Technology  
Nuclear Engineering Department  
373-1, Gusung-Dong  
Yusung, Taejon 305-701 Korea

Korea Institute of Nuclear Safety  
Advanced Reactor Dept.  
P.O. Box 114  
Yusung, Taejon 305-600 Korea

9. SPONSORING ORGANIZATION - NAME AND ADDRESS (If NRC, type "Same as above"; if contractor, provide NRC Division, Office or Region, U.S. Nuclear Regulatory Commission, and mailing address.)

Office of Nuclear Regulatory Research  
U.S. Nuclear Regulatory Commission  
Washington, DC 20555-0001

10. SUPPLEMENTARY NOTES

S. Smith, NRC Project Manager

11. ABSTRACT (200 words or less)

The objective of the present work is to improve the analysis capability of RELAP5/MOD3.1 on the direct contact condensation in the core makeup tank (CMT) of passive high-pressure injection system (PHIS) in the CARR Passive Reactor (CP-1300). The gravity-driven injection experiment is conducted by using a small scale test facility to identify the parameters having significant effects on the gravity-driven injection and the major condensation modes. The condensation modes are divided into three modes: sonic jet, subsonic jet, and steam cavity. RELAP5/MOD3.1 is chosen to evaluate the code predictability on the direct contact condensation in the CMT. It is found that the predictions of MOD3.1 are in better agreement with the experimental data than those of MOD3.0. From the nodalization study of the test section, the 1-node model shows better agreement with the experimental data than the multi-node models. RELAP5/MOD3.1 identifies the flow regime of the test section as vertical stratification. However, the flow regime observed in the experiment is the subsonic jet with the bubble having the vertical cone shape. To accurately predict the direct contact condensation in the CMT with RELAP5/MOD3.1, it is essential that a new set of the interfacial heat transfer coefficients and a new flow regime map for direct contact in the CMT be developed.

12. KEY WORDS/DESCRIPTORS (List words or phrases that will assist researchers in locating the report.)

CAMP  
RELAP5/MOD3

13. AVAILABILITY STATEMENT

unlimited

14. SECURITY CLASSIFICATION

(This Page)

unclassified

(This Report)

unclassified

15. NUMBER OF PAGES

16. PRICE