

Conf-941109--2

DOE/METC/C-95/7171

The U.S. Molten Carbonate Fuel-Cell Development and Commercialization Effort

Authors:

Mark C. Williams (DOE/METC)  
Edward L. Parsons, Jr. (DOE/METC)

Conference Title:

Fuel Cell Seminar

Conference Location:

San Diego, California

Conference Dates:

November 28 - December 1, 1994

Conference Sponsor:

Electric Power Research Institute  
Gas Research Institute  
U.S. Department of Energy

**MASTER**

DISTRIBUTION OF THIS DOCUMENT IS UNLIMITED

*Dec*

## DISCLAIMER

This report was prepared as an account of work sponsored by an agency of the United States Government. Neither the United States Government nor any agency thereof, nor any of their employees, makes any warranty, express or implied, or assumes any legal liability or responsibility for the accuracy, completeness, or usefulness of any information, apparatus, product, or process disclosed, or represents that its use would not infringe privately owned rights. Reference herein to any specific commercial product, process, or service by trade name, trademark, manufacturer, or otherwise does not necessarily constitute or imply its endorsement, recommendation, or favoring by the United States Government or any agency thereof. The views and opinions of authors expressed herein do not necessarily state or reflect those of the United States Government or any agency thereof.

This report has been reproduced directly from the best available copy.

Available to DOE and DOE contractors from the Office of Scientific and Technical Information, 175 Oak Ridge Turnpike, Oak Ridge, TN 37831; prices available at (615) 576-8401.

Available to the public from the National Technical Information Service, U.S. Department of Commerce, 5285 Port Royal Road, Springfield, VA 22161; phone orders accepted at (703) 487-4650.

## **DISCLAIMER**

**Portions of this document may be illegible in electronic image products. Images are produced from the best available original document.**

THE U.S. MOLTEN CARBONATE FUEL-CELL DEVELOPMENT  
AND COMMERCIALIZATION EFFORT

M.C. Williams

Project Manager, Power Generation Technology Branch

E.L. Parsons, Jr.

Chief, Power Generation Technology Branch

M.J. Mayfield

Product Manager, Fuel Cells

U.S. Department of Energy  
Morgantown Energy Technology Center  
P.O. Box 880, Morgantown, WV 26505

Abstract

We discuss the status of molten carbonate fuel-cell (MCFC) development in the U.S., including the role of the U.S. Department of Energy (DOE) in commercializing MCFC power-plant products for use by gas utility and electric power industries. We describe major fundamental stack research issues, as well as MCFC power-plant network and system issues, that need to be resolved before MCFC technology can be commercialized. A significant initiative in MCFC research is the spatial configuration of MCFC stacks into networks in a fuel-cell power plant.

Introduction

The DOE focus on energy, the environment, and the economy emphasizes the development of high-efficiency, environmentally acceptable, advanced, energy-conversion technologies for generating electricity. Congress has appropriated funding for the development and commercialization of these advanced energy-conversion technologies. The MCFC has been identified as a commercially promising energy-conversion product: overall system efficiencies of 50 to 60 percent are forecast for natural-gas and coal-gasification MCFC power plants. The MCFC, unlike turbines and diesels, offers high efficiency at small size and at part-load. Furthermore, an MCFC power plant can operate on coal or natural, refinery, or process gas.

MCFC stack designs incorporate either internal or external fuel and oxidant manifolding and either internal or external reforming. All MCFC designs include flat cell components in the cell package (i.e., anode, matrix to hold carbonate, cathode, current collector, and separator plate).

Figure 1 illustrates the structure of an MCFC stack. Conductive, bipolar separator plates connect the individual cells in a stack both structurally and electrically. The bipolar separator plate is made of stainless steel, and each plate physically separates the fuel-gas stream of one cell from the oxidant-gas stream of the adjacent cell. One side of each separator plate channels a fuel stream so that it flows over a porous anode, while the flip side channels an oxidant stream over a porous cathode. Each bipolar separator plate also collects current, thus electrically connecting adjacent cells of a stack in series. Electrons are conducted from the anode through the bipolar separator plate and into the cathode of the adjacent cell. There they react with the oxidant-gas stream and form carbonate ions. The carbonate ions diffuse through the electrolyte and into the anode, where they react with the fuel-gas stream, releasing electrons into the anode. Electrons are conducted in this manner through all the cells, thus establishing direct current (DC) through the stack. An external circuit connects a load between the two end plates of the stack, completing the circuit.

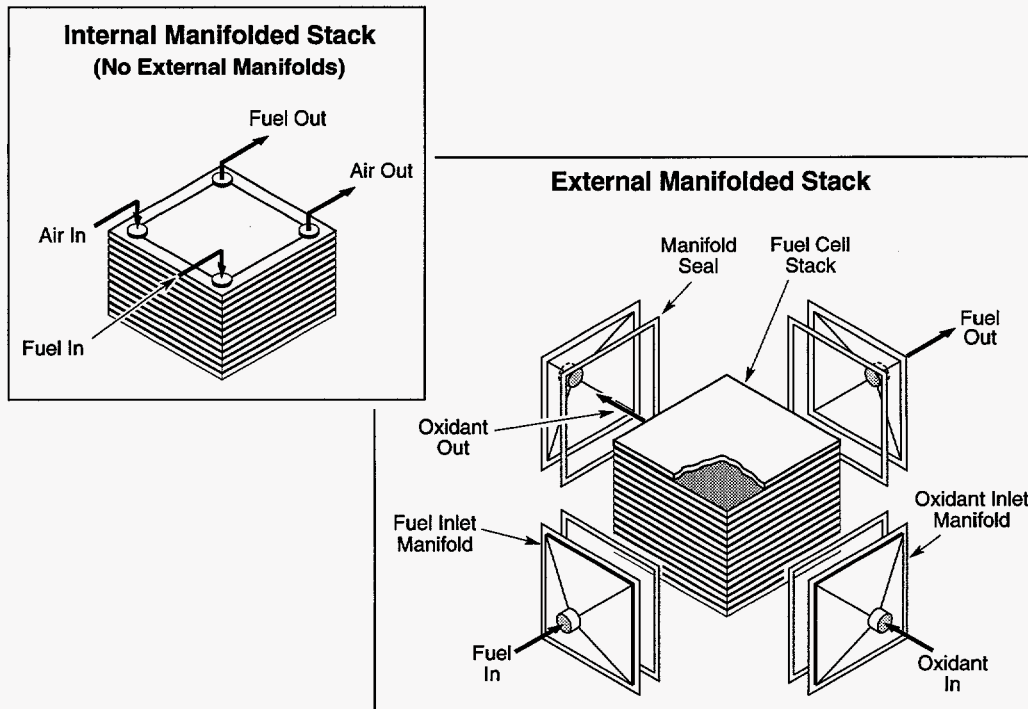

M93001769

Figure 1. MCFC Stack Structural Designs

At least two MCFC developers, Energy Research Corporation (ERC) and M-C Power (MCP), have conceptual designs of efficient integrated MCFC power plants. Operating conditions for these MCFCs are projected to be in the range of 150 to 250 amperes per square foot ( $\text{ft}^2$ )(160-270 milliamperes per square meter [ $\text{M}^2$ ]), at 0.60 to 0.80 volts, with 50- to 85-percent fuel utilization.<sup>1</sup>

#### Status of MCFC Program and Product Development Testing

The goal of the DOE MCFC program is to develop and commercialize low-cost, packaged, simple, and modular fuel-cell systems. DOE is accelerating the drive for private-sector commercialization of multi-fuel, MCFC power plants. The DOE's Morgantown Energy Technology Center (METC) is concluding support of MCFC power-plant system development with ERC and MCP under the 1990 Program Research and Development Announcement (PRDA).

The two MCFC developers have collected impressive stack-test performance data under the 1990

PRDA. ERC is developing an externally manifolder, externally reforming MCFC, and has constructed a 2 to 5 megawatt (MW) per year MCFC manufacturing plant. ERC has constructed a 100-kilowatt (kW) test facility in Danbury, Connecticut, and has scaled up to a 6- $\text{ft}^2$  (0.56  $\text{M}^2$ ) area stack. They have tested a 4- $\text{ft}^2$  (0.37  $\text{M}^2$ ), 75-kW, 234-cell stack for 500 hours at their facility in Danbury and also at the Pacific Gas and Electric, San Ramon, California, facility. ERC has also tested two 6- $\text{ft}^2$  (0.56  $\text{M}^2$ ), 123-kW, 244-cell stacks in Danbury.

MCP is developing an internally manifolder, externally reforming MCFC, and has constructed a 3-MW per year MCFC manufacturing plant. MCP has constructed a 250-kW acceptance test facility in Burr Ridge, Illinois, and has scaled up to an 11.4- $\text{ft}^2$  (1.06  $\text{M}^2$ ) full area stack. They have tested several sub-scale-area stacks, including a 1- $\text{ft}^2$  (0.09  $\text{M}^2$ ), 7-kW, 70-cell stack. MCP has also tested three, 20-kW full-area stacks for over 1,000 hours.

The 1990 PRDA DOE contracts with these MCFC contractors will culminate with tests of 100- to 250-kW, full-area, full-height MCFC power-plant

systems on simulated coal gas, refinery gas, and natural gas in 1994. Further testing of the 100-kW class MCFC at ERC in Danbury, Connecticut, is planned in 1994. Testing of a 250-kW, full-area stack is planned by MCP at the UNOCAL Science and Technology Center in Brea, California, in late 1994.

DOE funded Product Development Tests (PDTs) concurrently with system development at ERC and MCP under the 1990 PRDA to establish a proven track record for emerging MCFC technology in the utility and industrial arenas. A successful demonstration track record will enhance support for MCFC technology from utilities and other end-users in the distributed, repowering, American Public Power Association, industrial, and commercial markets.

The initial MCFC PDTs will be in California in 1995. ERC will conduct a 2-MW PDT in Santa Clara, California, funded by the Santa Clara Demonstration Group, the Electric Power Research Institute, and DOE. MCP will conduct a 250-kW PDT in San Diego, California, funded by DOE, the Gas Research Institute, and San Diego Gas and Electric. ERC is also participating in a 2-MW Clean Coal Technology V Demonstration project with DOE and Duke Power at a site to be determined.

#### Stack Technology, System and Network Issues

DOE assessed the status of MCFC technology and commercialization potential based on recent accomplishments under the 1990 PRDA contracts. DOE found that critical technology, design, and manufacturing issues remain that can hinder commercialization. Technology issues include (1) electrode and separator plate corrosion, (2) power density, (3) thermal cycling, (4) scale-up, and (5) gas leakage and cross-over. These affect endurance and longevity, power density, and cost. The major long-term issue in MCFC operation is cathode corrosion.<sup>2,4</sup> Major network and system issues are cost, heat loss management, footprint, packaging and integration, parasitic power losses, pressurization, and reforming.

Pressurization affects stack and balance-of-plant (BOP) development.<sup>2</sup> A potential advantage of pressurized operation is higher power density (or smaller stack size for a given application). System integration and packaging of MCFC power plants will increase efficiency, power density, reliability, and ease of maintenance and will reduce heat loss, footprint, and capital and field installation costs.

With the initial demonstration of full-area, full-height 250-kW to 2-MW MCFC power plants, the spatial configuration of MCFC stacks into networks in the fuel-cell power plant takes on new importance. Conventional fuel-cell systems have multiple stacks arranged in parallel with the flow of reactant streams. As illustrated in Figure 2, the initial oxidant and fuel feeds are divided into equal streams, which flow in parallel through the fuel-cell stacks. Reactant streams can also be ducted so they flow through a recycle network in series. Figure 2 also shows how reactant streams in a fuel-cell network flow in series from stack to stack.

METC researchers recently completed computer simulations to evaluate the performance of various internal reforming networks and to compare conventional and networked MCFC power systems.<sup>5</sup> The simulated performance of MCFC networks was superior to the performance of cells and stacks that were not networked.

#### Planned MCFC Product Design and Improvement Program

DOE recently issued a Product Design and Improvement (PDI) PRDA to resolve technology, system, and network issues. The objective of this work is to aim current MCFC stack development toward the development of a packaged, commercializable MCFC product. Contracts under this PRDA will bring a multi-fueled, integrated, simple, low-cost, modular, market-responsive MCFC power plant to the marketplace. The development program will be based on a commercialization plan to manufacture and package, demonstrate, and aggressively market MCFC power plants. The PDI PRDA will culminate in the manufacture and construction of high-performance, low-cost, 500- to 2,000-kW MCFC power-plant module(s).

Conditional selection has been made in the MCFC PDI PRDA, and again, ERC and MCP have been selected. A conditional statement was added to the selection statement that indicates eventual awards are contingent upon a favorable Energy Policy Act Determination by the DOE Secretary O'Leary.

ERC and its two subsidiaries, Fuel Cell Engineering Corporation and Fuel Cell Manufacturing Corporation, plan a 5-year, private-sector, cost-shared program for product improvement and verification, with an emphasis on multi-fueled, integrated, simple,

low-cost, modular, and market-responsive MCFC power-plant development in the 2-MW-size range.

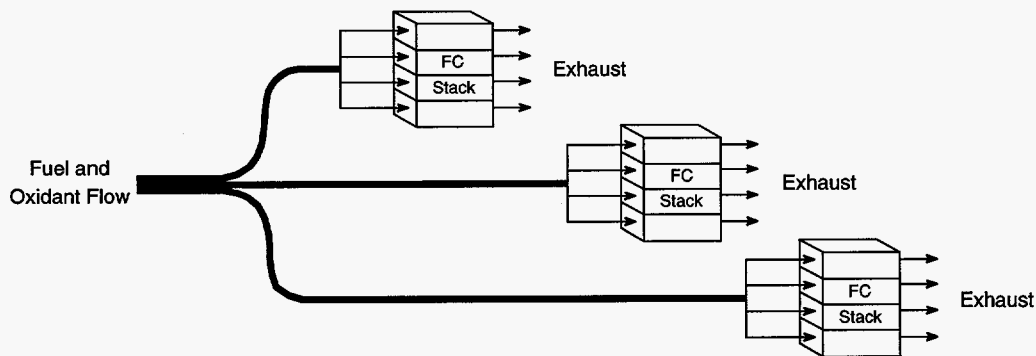

(a) Parallel Flow of Reactant Streams Through Stacks

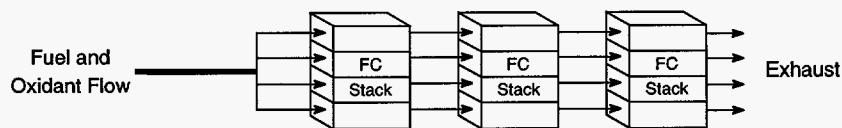

(b) Series Flow of Reactant Streams Through Stacks

M93001844

Figure 2. MCFC Networks

The work will encompass (1) further product definition that reinforces the desired attributes and also follows strong interest of many utility companies in 2-MW-size systems, (2) power-plant design that includes stack and BOP modules, (3) manufacturing process improvements and commercial facility design, (4) cell area scale-up to 8,000 cm<sup>2</sup> and testing of full-size stacks that have approximately 300 cells and a capacity rating of 250 kW, (5) development of critical BOP equipment, and (6) verification of power-plant modules.

ERC will be developing an internal reforming MCFC system that eliminates the external reformer equipment and associated heat exchangers used in other fuel-cell systems. This system is therefore simple and has inherently high efficiency. An efficiency goal of 55 percent (based on a lower heating value of fuel) for a natural-gas plant appears achievable. Based on input from both municipal- and investor-owned utilities, the initial target for market penetration will be 2-MW natural-gas power plants for baseload and dispersed generation applications.

MCP will join with Bechtel Corporation of San Francisco, California; Stewart & Stevenson Services of Houston, Texas; and the Institute of Gas Technology of Chicago, Illinois, as a new company called IMHEX®. Team members plan a 4-year, private-sector, cost-shared program for product improvement. The primary objective of the MCP effort is to establish, by 1998, the commercial readiness of MW-class IMHEX® MCFC power plants for distributed generation and cogeneration applications.

The program focus is cost reduction and verification of product durability, reliability, and performance. Achieving cost reduction goals will require advanced stack technologies that simplify design and fabrication, and BOP designs that are driven by equipment improvements and integration opportunities. Achievement of these goals will be verified through the design, construction, and operation by 1997 of a high-performance, low-emissions, natural-gas-fueled, nominal 1-MW IMHEX® fuel-cell power plant. Southern California Edison Company of Rosemead, California, will host the 1-MW IMHEX®

MCFC power plant demonstration. This power plant is the initial market-entry product prototype, and utilizes pressurized operation and a reformer/catalytic combustor that is thermally integrated but independent of the stack assembly.

Many challenges for MCFC developers remain. DOE recognizes that funding support is needed in six areas: (1) product definition and planning; (2) system design and analysis; (3) manufacturing process development; (4) assembly and packaging; (5) test facility development; and (6) technology development, improvement, and verification. However, DOE is also concerned with the growing funding requirements for fuel-cell development and commercialization. Various options are being considered to limit Government costs, including reducing the number of designs and concepts being developed, limiting the size and number of demonstrations, increasing the cost share, and combining or limiting development work on the BOP sections.

Strategic issues, program objectives, and planned activities in the MCFC product arena have been identified.<sup>6,7</sup> One specific DOE MCFC development objective is to complete a 10-MW MCFC PDT by 1998.

#### Conclusion

DOE has identified the MCFC as a promising energy-conversion product for development and commercialization. MCFC technology developers are making significant progress: technological achievements, manufacturing facility development, and extensive testing are occurring. However, several critical issues need to be resolved through research and demonstration under the Product Design and Improvement Program. In addition, MCFC developers need to continue to be responsive to end-users in distributed, repowering, American Public Power Association, industrial, and commercial markets.

#### References

1. Williams, M.C., and T.J. George, 1990, "The Developmental Status of Coal-Fueled Molten Carbonate Fuel Cell Power Plants," Proceedings of the 25th IECEC, 3, pp. 185-92.
2. Williams, M.C., and T.J. George, 1991, "Cathode Corrosion in MCFCs," Proceedings of the 26th IECEC, 3, pp. 40-51.
3. Energy Research Corporation, 1987, Molten Carbonate Fuel Cell Development, Final Report to U.S. DOE under Contract No. DE-AC21-76ET11304.
4. Selman, R., Y. Yazici, and Y. Izaki, 1993, "NiO Cathode Dissolution in the MCFC: A Review," Preprints of Papers 206th ACS National Meeting, Chicago, IL, 38, pp. 1429-1434.
5. Wimer, J., and M. Williams, 1993, MCFC Networks: Principles, Analysis and Performance, DOE/METC-93/4112 (NTIS DE93000281).
6. Williams, M.C., and M.J. Mayfield, 1992, "Strategic Planning for MCFC Development and Commercialization," Fuel Cell Seminar Program and Abstracts, pp. 442-445.
7. Morgantown Energy Technology Center, 1993, Fuel Cell Product Plan, unpublished.