

**Title: THE MECHANICAL DESIGN AND FABRICATION OF A RIDGE-LOADED  
WAVEGUIDE FOR AN RFQ**

**Author(s): Robert Valdiviez  
Phillip L. Roybal  
William L. Clark  
Felix A. Martinez  
Donald E. Casillas  
Steven G. Gonzales  
Joseph E. P. Tafoya**

LANSCE-1  
LANSCE-1  
LANSCE-1  
LANSCE-1  
ESA-WMM  
ESA-WMM  
ESA-WMM

**Submitted To: LINAC '98  
XIX INTERNATIONAL LINAC CONFERENCE  
CHICAGO, IL      AUGUST 23-28, 1998**

RECEIVED  
APR 13 1999  
OSTI

**MASTER**

DISTRIBUTION OF THIS DOCUMENT IS UNLIMITED

## **DISCLAIMER**

**This report was prepared as an account of work sponsored by an agency of the United States Government. Neither the United States Government nor any agency thereof, nor any of their employees, makes any warranty, express or implied, or assumes any legal liability or responsibility for the accuracy, completeness, or usefulness of any information, apparatus, product, or process disclosed, or represents that its use would not infringe privately owned rights. Reference herein to any specific commercial product, process, or service by trade name, trademark, manufacturer, or otherwise does not necessarily constitute or imply its endorsement, recommendation, or favoring by the United States Government or any agency thereof. The views and opinions of authors expressed herein do not necessarily state or reflect those of the United States Government or any agency thereof.**

## **DISCLAIMER**

**Portions of this document may be illegible in electronic image products. Images are produced from the best available original document.**

# THE MECHANICAL DESIGN AND FABRICATION OF A RIDGE-LOADED WAVEGUIDE FOR AN RFQ

R. Valdiviez, P. Roybal, B. Clark, F. Martinez, D. Casillas, G. Gonzales, J. Tafoya  
Los Alamos National Laboratory, Los Alamos, NM, 87545

## Abstract

A Radio Frequency Quadrupole (RFQ) accelerator with an RF power input of 2 MW and an H<sup>+</sup> beam output current of 100 mAmps at 6.7 MeV, continuous duty factor utilizes twelve nearly identical ridge-loaded waveguides. The ridge-loaded, vacuum waveguides couple the RF power to the RFQ accelerating cavity. The mechanical design and fabrication of the ridge-loaded waveguides are the topics of this paper.

## 1 RFQ AND RF POWER SUPPLY DESCRIPTION

The RFQ linac [1] is made of eight different sections that are joined together with a flange type of design. Each section is approximately one meter in length and weighs approximately 680 pounds.

RF power is supplied at three different sections of the RFQ. RF feed sections have four rectangular shaped ports each that are sized to accept the nose piece of the ridge-loaded waveguide. The nose piece of the waveguide actually becomes part of the cavity wall, with the face being part of the cavity surface.

The RF power is supplied to the RFQ by three separate klystrons rated for 1 MW operation each at 350 MHz. The output of each klystron is divided four ways to create twelve waveguide runs of nominally 167 kW each. An RF window [2] is used to separate the air and vacuum waveguide runs on each waveguide arm.

## 2 BASIC RF CHARACTERISTICS DESIGN OF THE RIDGE-LOADED WAVEGUIDE

The tapered ridge-loaded waveguide operates in the dominant TE<sub>10</sub> mode, the same mode as in the half height WR2300 waveguide used for the airside RF waveguide. The ridge in the waveguide begins at a location in the waveguide approximately twenty-four inches from the RFQ inner wall and increases in height, while both the height and width of the waveguide are reduced. The RF fields have intensified sufficiently at the end of the ridged waveguide to couple the RF power into the RFQ cavity with an iris slit small enough to not

perturb the tuning of the RFQ. The cutoff frequency of any cross section through the tapered ridge-loaded waveguide is equal to the cutoff frequency of the WR2300 waveguide.

## 3 THERMAL/STRESS ANALYSIS OF THE RIDGE LOADED WAVEGUIDE

### 3.1 First Ridged Waveguide Section

The waveguide arm connecting the RFQ to the RF window is actually made up of three vacuum waveguide sections. The first two sections are the ridge-loaded sections. The third section is a straight section of waveguide that includes a vacuum pumping port for pumping the waveguide arm [3].

A section view of the ridged waveguide is shown in Figure 1. The first waveguide section connects to the RFQ and forms part of the cavity wall as described previously. The weight of the waveguide is 97 pounds. This configuration places a considerable heat load on the waveguide. Integral coolant channels within the waveguide body are used to provide the necessary temperature control of the waveguide. Water from the Resonance Control Cooling System (RCCS) [4] is used in the waveguide coolant channels. Since the waveguide becomes part of the resonating cavity wall it must be thermally controlled as the rest of the cavity walls.

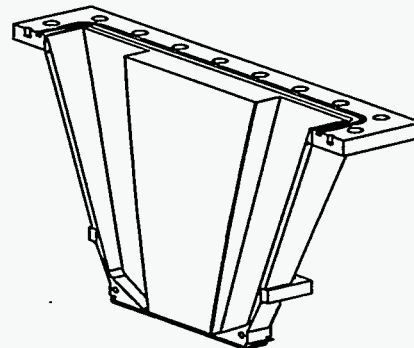

Figure 1. First Ridged Waveguide Longitudinal Section View

Two parallel coolant channels run down through the ridge, make several turns in a region immediately

behind the iris piece, and flow up and out of the waveguide. The bulk coolant velocity is 15 feet/second in the iris region, and 12.8 feet/second in the supply and return channels in the ridge bodies. This cooling configuration allows for the power loss heat load, that ranges from  $5.2 \times 10^{-3}$  Btu/s-in<sup>2</sup> to  $1.8 \times 10^{-3}$  Btu/s-in<sup>2</sup> to be accommodated. The high thermal conductivity of the copper material allows for using only two discrete coolant channels to cover a rather wide surface area without creating substantial temperature gradients.

The thermal/stress Finite Element Analysis (FEA) model of the waveguide was created and analyzed using the program COSMOS/M, version 1.75A [5]. The waveguide geometry was obtained from the solid modeling software Unigraphics, version 11.1.3 [6] by using an IGES translation file.

The thermal profile of the waveguide was first predicted. The peak temperature predicted was 106 °F for normal conditions, with an inlet coolant temperature of 66 °F. This peak temperature occurs in the iris region where the peak heat load is located. This thermal profile is then used as one of the boundary conditions in a displacement and stress model. The largest displacement is predicted to be 0.0022 inch at the top of the waveguide. The peak von Mises stress is predicted to be 6540 lb<sub>f</sub>/in<sup>2</sup> and occurs in the iris region. The iris region is locked between the lower mounting flange of the waveguide and the RF seal that the nose piece of the waveguide presses against. The RF seal acts as a very stiff spring that has some pliability, yet still offers significant resistance to the thermal growth of the nose portion of the waveguide.

Due to the value of the predicted peak von Mises stress in the waveguide the high strength copper material Glidcop AL-15 [7] was chosen as the material of construction for the waveguide.

### 3.2 Second Ridged Waveguide Section

Figure 2 is a section view of the second ridged waveguide. The second ridged waveguide section connects to the first section, is the section where the ridge begins, and weighs 186 pounds. One end of the waveguide matches the half-height WR2300 waveguide dimensions. The bottom end dimensions of this waveguide match to within a few thousandths of an inch to the first waveguide.

The waveguide has four separate coolant flow channels. The channels are located in the corner regions of the ridge. The bulk coolant velocity in each channel is 6 feet/second. The coolant water from the first section is split and sent into the second section. The power loss

heat load on the second section ranges from  $1.3 \times 10^{-3}$  Btu/s-in<sup>2</sup> to  $3.2 \times 10^{-4}$  Btu/s-in<sup>2</sup>.

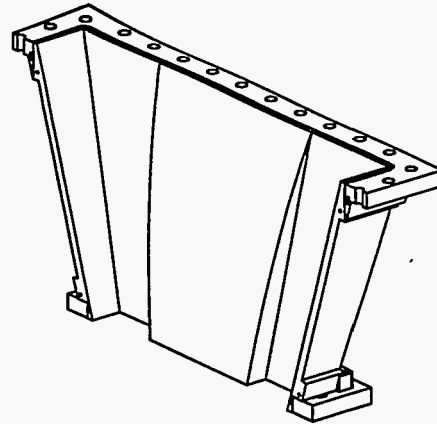

Figure 2. Second Ridged Waveguide Longitudinal Section View

The thermal/stress Finite Element Analysis (FEA) model of the second waveguide was created and analyzed using the program COSMOS/M, version 1.75A. The waveguide geometry was obtained from the solid modeling software Unigraphics, version 11.1.3 by using an IGES translation file.

The FEA model was first used to predict the thermal profile of the second waveguide. The peak temperature was predicted to be 81 °F located in the lower part of the waveguide sidewall, for an inlet coolant temperature of 72 °F. This location is one of the furthest from a coolant channel. The predicted thermal profile was used as a boundary condition for the displacement and stress model. The largest displacement was predicted to be 0.0013 inch at the top of the waveguide. The peak von Mises stress is predicted to be 3680 lb<sub>f</sub>/in<sup>2</sup> located in a lower corner region of the waveguide.

The predicted von Mises stresses are not too high for the second section. For this reason OFE C10100 copper was chosen as the material of construction.

## 4 MECHANICAL DESIGN OF THE RIDGE-LOADED WAVEGUIDE

The mechanical design used the results of the thermal and stress analyses to determine a final design that would meet both strength and space envelope constraints. Initial concepts of each of the waveguide designs had been created using the solid modeling software Unigraphics, version 11.1.3.

The thermal and stress analyses of both waveguide sections predicted some areas where the initial design required some modification. The size of the coolant channel in the iris waveguide, in the region immediately behind the iris piece was changed in order to obtain the thermal/hydraulic conditions needed to achieve the desired thermal profile in this part of the waveguide body. The body of the second waveguide section was predicted as needing reinforced sections in the flange areas in order to reduce the combined stress levels.

## 5 FABRICATION METHODS EMPLOYED

The ridged waveguide sections are machined copper assemblies with the individual parts joined together by using the brazing process. The internal ridge and pocket configuration of both sections along with the tapering in two planes over the length of the section required skillful machining. The geometry of, and the mechanical loads placed on the braze joints required equally skillful preparation and brazing.

### 5.1 Machining

Each waveguide section is machined in two halves that are eventually joined together. By using this approach the internal ridge and pockets can be machined in an open face configuration. The dimensional tolerance of the internal features was +/- 0.005 inch or less. Several three axis machines and a five axis machine were used to produce the waveguide bodies.

Due to the fact that the internal surfaces and features see high RF power the surface finishes and feature sizes, such as corner radii took on more importance than they normally would in a non-RF power component. Sample pieces were machined out of aluminum for both waveguide sections to check for surface finish and feature sizes obtainable, and to check the machine programming. After undergoing a few iterations with samples the actual copper machining was begun.

### 5.2 Brazing

Gold-copper alloys were used to braze the various pieces of the waveguides together. Brazing the OFE C10100 presented no major problems due to the long experience of brazing this copper material. Brazing OFE C10100 to Glidcop AL-15 presented some problems with joint sealing and joint strength. Brazing Glidcop AL-15 to Glidcop AL-15 presented increased sealing and strength problems.

In order to overcome the problem of Glidcop joint seal and strength integrity several vacuum and tensile

specimens were fabricated and put through variations of the basic brazing procedure being used. In summary the first sample investigations provided some improvement steps, but nothing that achieved consistent seal and strength integrity. Throughout this testing process other users of Glidcop were consulted about the problem. The Stanford Linear Accelerator Complex (SLAC) advised that their best success in brazing Glidcop came from first plating the surfaces to be brazed with a 0.0008 inch thick copper strike in a cyanide-copper plating process. This method of preparing the braze surface was employed on several sample pieces with very good, consistent results in sealing and strength. The preparation method was added to the fabrication sequence of the waveguide sections, and has worked well on the parts brazed to date.

## 6 RESULTING WAVEGUIDE HARDWARE

At the time of preparing this paper the ridged waveguide sections were still being fabricated, so no high RF power operation has been conducted yet with this ridged waveguide design. Since the desired RF design has been able to be manufactured with no major changes the waveguides are expected to perform as required.

## 7 REFERENCES

- [1] D. Schrage et al, "CW RFQ Fabrication and Engineering," these proceedings.
- [2] K. Cummings et al, "Results and Lessons Learned From Conditioning 1 MW CW 350 MHz Coaxial Vacuum Windows," these proceedings.
- [3] S. Shen et al, "APT/LEDA RFQ RF Window Vacuum Pumping System-Conceptual Design Report," LLNL Report APT/RFW-091797-001.
- [4] R. Floersch, "Resonance Control Cooling System for the APT/LEDA RFQ," these proceedings.
- [5] Structural Research and Analysis Corp., "COSMOS/M User Manual," version 1.75A, March, 1996.
- [6] EDS Corporation, "Unigraphics User Manual," version 11.1.3, 1996.
- [7] OMG Americas Corp., "Glidcop Dispersion Strengthened Copper, Glidcop AL-15 (C15715)," Technical Data Sheet, August, 1989.