

MONITORING ROOF BEAM LATERAL DISPLACEMENT AT THE WASTE ISOLATION PILOT PLANT

by

L. J. Terrill and R. E. Lewis

Westinghouse Electric Corporation
Waste Isolation Division
Carlsbad, New Mexico

ABSTRACT

ABSTRACT: Lateral displacement in the immediate roof beam at the Waste Isolation Pilot Plant (WIPP) is a significant factor in assessment of excavation performance for the design of ground control systems. Information on roof beam lateral displacement, expansion, fracture formation, as well as excavation convergence, is gathered using a variety of manually and remotely read instruments. Visual observations are also used when possible. This paper describes the methods used to measure lateral displacement, or offset, at the WIPP. Offset magnitudes are determined by the degree of occlusion in drillholes that intersect the offset plane. The Borehole Lateral Displacement Sensor (BLDS) was developed for installation at WIPP to monitor offset at a high degree of accuracy at a short reading frequency. Offset measurements have historically been obtained by visual estimation of borehole occlusion. Use of the BLDS will enable relationships between time dependent roof beam lateral displacement and expansion to be established in much shorter periods than is possible using visual observations. The instrument will also allow remote monitoring of roof beam displacement in areas where visual estimations are not possible. Continued monitoring of roof beam displacement, convergence, and expansion, is integral to timely and pertinent assessments of WIPP excavation performance.

INTRODUCTION

The Waste Isolation Pilot Plant (WIPP) was authorized by Congress in 1979 (Public Law 96-164) to provide "...a research and development facility to demonstrate the safe disposal of radioactive wastes resulting from the defense activities and programs of the United States exempted from regulation by the Nuclear Regulatory Commission (USDOE, 1992). To fulfill this mission, the U.S. Department of Energy (DOE) is constructing WIPP as a full-scale facility to demonstrate both technical and operational principles of the permanent isolation of transuranic waste. The facility is being developed in bedded salt in the United States about 50 km (30 miles) east of Carlsbad, New Mexico. The facility is also designed for in-situ studies and experiments in salt.

DISTRIBUTION OF THIS DOCUMENT IS UNLIMITED

UM

MASTER

DISCLAIMER

**Portions of this document may be illegible
in electronic image products. Images are
produced from the best available original
document.**

WIPP BACKGROUND

The National Academy of Sciences selected salt as an appropriate host medium for permanent disposal of transuranic (TRU) waste because of its low permeability, fracture healing, and plastic creep properties, which are ideal for prevention of contaminant migration. The WIPP will receive, handle, and permanently dispose of TRU waste in an underground facility being developed within the Permian Salado Formation (Figure 1).

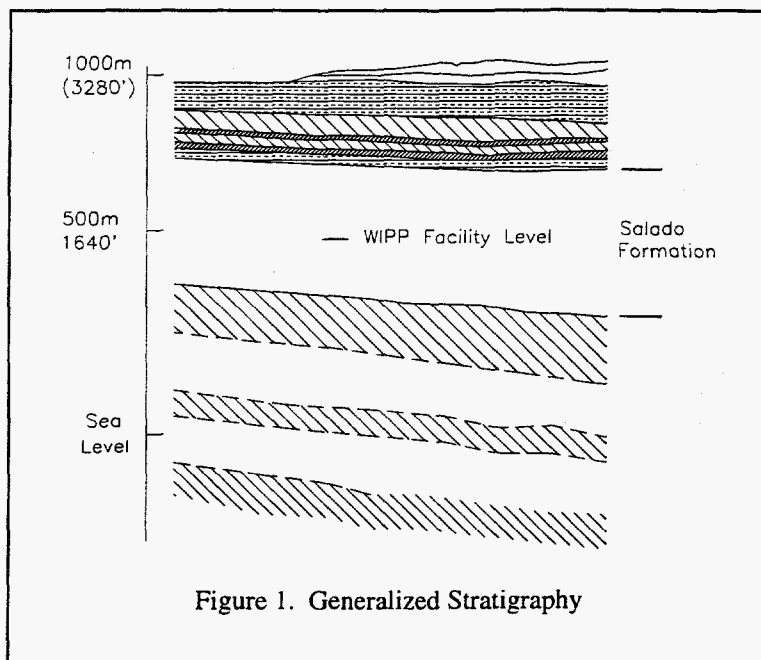

Figure 1. Generalized Stratigraphy

The Salado Formation is approximately 2000 feet thick and is composed predominantly of halite with minor amounts of clay, anhydrite, and polyhalite. Several persistent layers of anhydrite and polyhalite occur within the formation. The WIPP facility lies approximately 655 meters (2,150 feet) beneath the surface, near the center of the Salado. The facility excavations lie in two horizons: the disposal horizon and the experimental horizon. The scope of this paper is limited to studies performed at the disposal horizon; discussion of stratigraphy and rock deformation will be limited to this horizon.

The disposal horizon is a thick (12 m) evaporite sequence consisting of halite, argillaceous halite, and polyhalitic halite (Figure 2). Thin beds of anhydrite are laterally consistent within this sequence. Anhydrite "a" and Clay H lie about four meters (13 feet) above the excavations. Anhydrite "b" and clay G lie about two meters (7 feet) above the excavations. These anhydrite beds and their associated clay seams are the most structurally important units and clay G defines the upper bound of the immediate roof beam in these excavations.

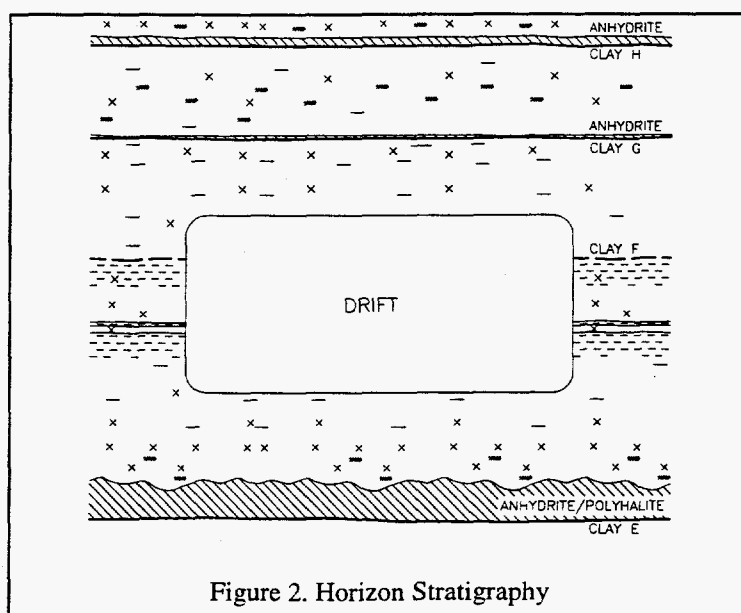

Figure 2. Horizon Stratigraphy

The underground workings can be divided into three areas: the Site and Preliminary Design Validation (SPDV) area in the northwestern portion of the facility; Panel 1 in the southeastern portion; and the central access drifts (Figure 3). The access drifts are typically about 3 meters (12 feet) wide while rooms in the SPDV and Panel 1 areas are ten meters (33 feet) wide.

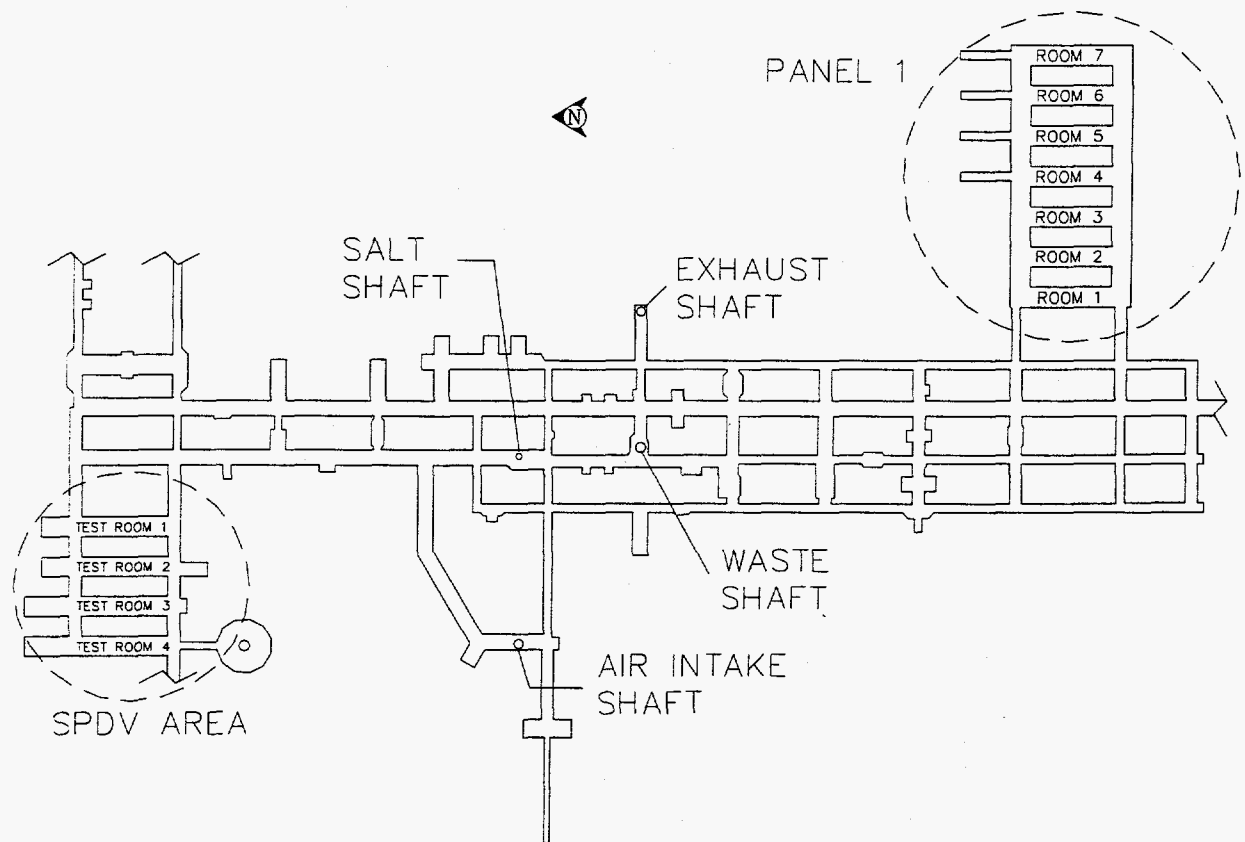

Figure 3. Disposal Horizon Drift Layout

ROCK DEFORMATION MONITORING

Deformation and fracturing of the salt occurs throughout the mine as a result of continuous creep deformation. The geomechanical response of the underground openings is monitored using geomechanical instruments, visual inspections of excavation surfaces, and logging of cores and open boreholes.

Geomechanical Instrumentation

A variety of geomechanical instruments are installed throughout the mine to monitor rock deformation. Manually read convergence monitoring stations comprise the majority of instruments and provide data on surface displacement and closure for the entire underground workings. Closure in inaccessible areas is monitored using remotely read convergence meters.

Borehole extensometers are used to monitor expansion of the salt in the roof beams and possible separation occurring at the clay seams, with particular attention given to separation at clay G. Other instruments, including rock bolt load cells, pressure cells, and strain gauges provide information on loading of support materials.

The combined acquired geomechanical instrumentation data typically provide information on movement of the salt normal to the excavation surfaces and are used to provide continuing confirmation of excavation performance as determined by design criteria. The data are also used in the design and evaluation of ground support systems.

Observation Borehole Inspections

Observation boreholes are drilled into the roofs of the excavations and inspected to determine conditions within the immediate roof beam. Boreholes are inspected using an aluminum probe rod with a flattened nail attached normal to one end. Fractures and clay seams are located by moving the nail along the sides of the borehole until it catches in one of these features. Depths to the features are recorded along with any separations encountered. Lateral displacement, or offset, at any feature is determined by visually estimating the degree of borehole occlusion. Figure 4 depicts the view into a 7.6 cm (3 inch) borehole with a 2.5 cm (1 inch) occlusion at clay G.

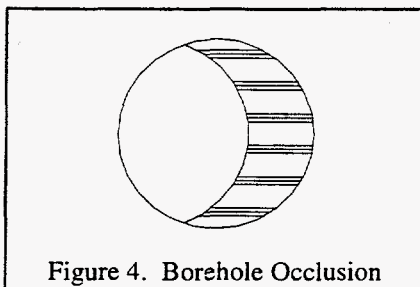

DISCUSSION OF EXCAVATION EFFECTS

The results from geomechanical monitoring, borehole inspections, and observations of excavation surface fractures were used to develop a conceptual model for the pattern of excavation effects at the WIPP (Figure 5). This pattern is typical for most WIPP excavations and manifests as a function of excavation geometry, age, and roof beam thickness.

Vertical loading of the pillars causes the ribs to move horizontally into the excavations. Because clay G offers very little resistance to this horizontal movement, differential lateral movement of the roof beam occurs along the clay toward the centerline of the excavations. Diagonal fractures observed in the roofs near the ribs typically slant upward at about 20 to 25 degrees from horizontal towards the centerline. Cross-sectional graphical representation of borehole inspection data often reveals a wedge outlined by fractures found in the boreholes. Fracturing and observed movement on one side may become more pronounced, indicating a cantilevered condition. Convergence data and roof expansion data often corroborate this condition, with higher convergence and expansion occurring on the side of pronounced fracturing.

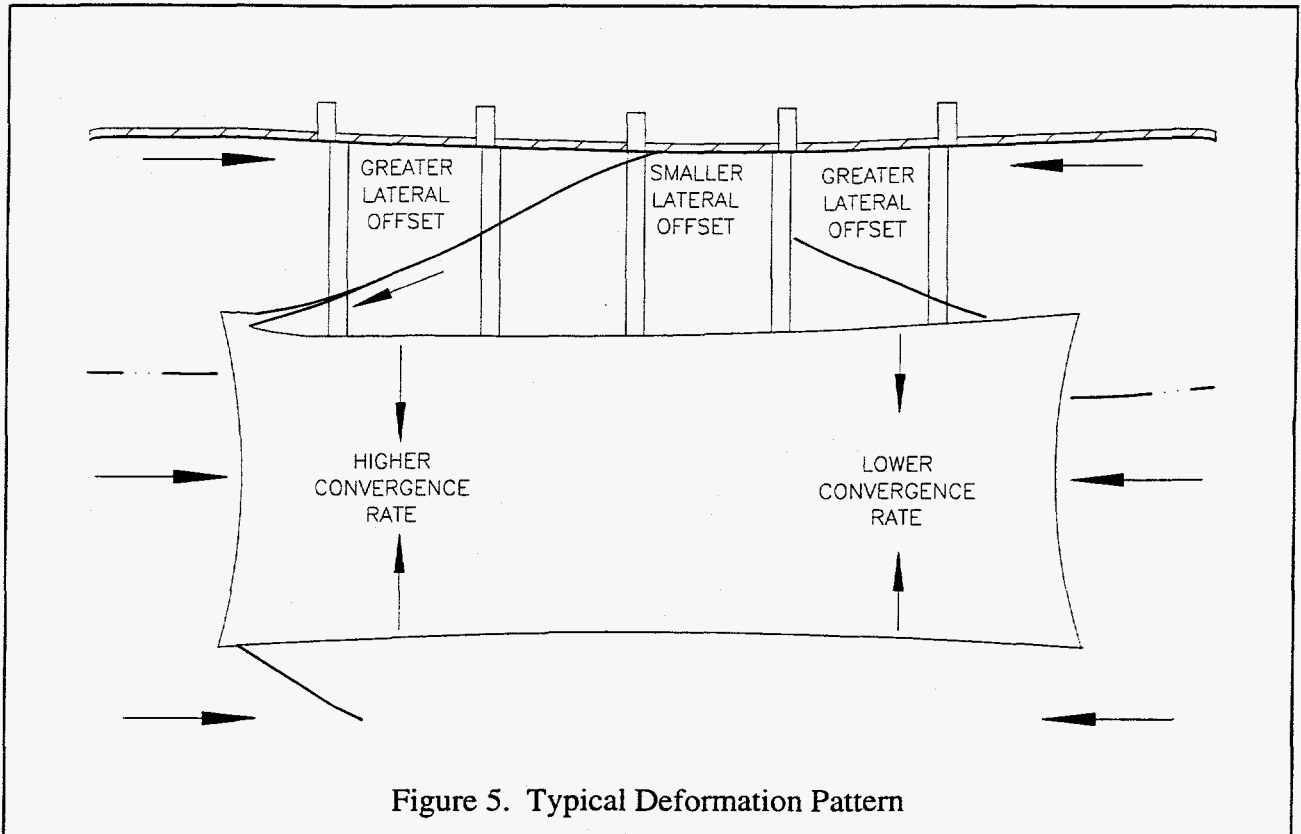

Observations of lateral movement in boreholes that intersect the clay seam have revealed lateral offset rates of up to 32 mm (1 1/4 inch) per year with the greatest offset magnitudes occurring near the ribs regardless of excavation width.

Two SPDV room roof falls were predicted and monitored using the results of excavation monitoring. Indications of roof instability were observed in the borehole observation and instrument data well before the falls of ground. Fractures in the roofs were noticed shortly after excavation and were monitored as they increased in length. The borehole fracture observations demonstrated the development of wedge shaped sections in the roofs bounded by diagonal fractures. Convergence data showed that convergence on one side of each room closing twice as fast as the opposing side. This was also true of the rate of separation at clay G measured by extensometers in one room. The actual falls of ground displayed the shape predicted by the observations.

CONSIDERATION OF LATERAL DISPLACEMENT IN DESIGN OF SUPPLEMENTARY ROOF SUPPORT SYSTEM

Ground control is used at WIPP, not to halt the process of closure, which is desirable for containment of the nuclear wastes, but to provide for continued safe use of the excavations during waste emplacement. Standard mechanically anchored rock bolts have been installed in

the majority of drifts and are anchored above clay G. The typical roof beam deformation pattern affects these bolts in similar ways throughout the underground workings. Broken bolts are usually found to exhibit bending at the breaks associated with lateral displacement at the clay seam. This consistency in support performance was applied in the design of a supplementary roof support system for Panel 1, Room 1 (Figure 3).

Movement of the roof beam occurs along clay G in Panel 1, Room 1, as expected. Therefore, oversized boreholes (from the collar to just past the clay seam) were drilled to create extra annular space between the salt and the bolts to allow more differential movement of the strata to occur before contacting and bending the bolts.

QUANTIFYING LATERAL DISPLACEMENT RATES

Most of the WIPP roof beam data is obtained from geomechanical instrumentation which allow a high reading frequency at a high accuracy, even in areas that must be remotely monitored. The data are used to assess and predict excavation performance and are very useful for correlation with modeling, which can show changes in rock at discrete times since excavation.

Lateral displacement along the clay layers is also a consideration in analyses of excavation performance. Rates of displacement, when available, are evaluated for localized sections of drifts, especially when determining periods for optimal bolt installation. Because magnitudes of lateral displacement can only be visually estimated to within about 4 mm (1/8 inch), several months must often pass before a change in magnitude can be seen. This results in irregular frequencies between recordings of observable changes in displacement, making accurate rate calculations difficult.

Other factors contribute to difficulty in determining calculations of displacement rates. Because the displacements are visually observed, the estimated magnitudes are subjective. It is desirable that one person perform the observations to ensure continuity of the data. This approach has proven very satisfactory, however it is not always practicable. Of course, no data is available for areas to which access has been prohibited. These factors, and the need for a higher reading frequency prompted the development of the Borehole Lateral Displacement Sensor.

BOREHOLE LATERAL DISPLACEMENT TRANSDUCER

The Borehole Lateral Displacement Sensor (BLDS) was developed to:

1. Ease the manual requirement in examining borehole offset.
2. Allow remote monitoring of displacement along clay G in areas of restricted or prohibited access..
3. Provide a high measuring accuracy, thereby allowing a higher reading frequency.

Moreover, the BLDS can accurately describe the displacement vector, quantifying both magnitude and direction. Visual determinations of the direction of displacement are limited to West, South, Southwest, etc. and, like the magnitudes, often require several months passage of time before they are observable to the naked eye. The BLDS can detect this vector very soon after installation.

DESCRIPTION

The Borehole Lateral Displacement Sensor (Figure 6) is comprised of dual components, the optical target and the digital imaging section. Central to the digital imaging section is a two-dimensional Charged Coupled Device (CCD) similar to those found in video camcorders. A two-dimensional CCD can be viewed as an array of closely spaced, light sensitive, pixel-like points. Additional components include a light source, optics and a microprocessor to control operations. The device is powered by a 12 volt battery with a quiescent current draw of less than one milliamp. Control of the device is through serial (RS-232) communication with a laptop PC. For installations in areas where access is prohibited, the communication signal is converted to RS-485 for transmission over much longer distances than can be achieved through RS-232.

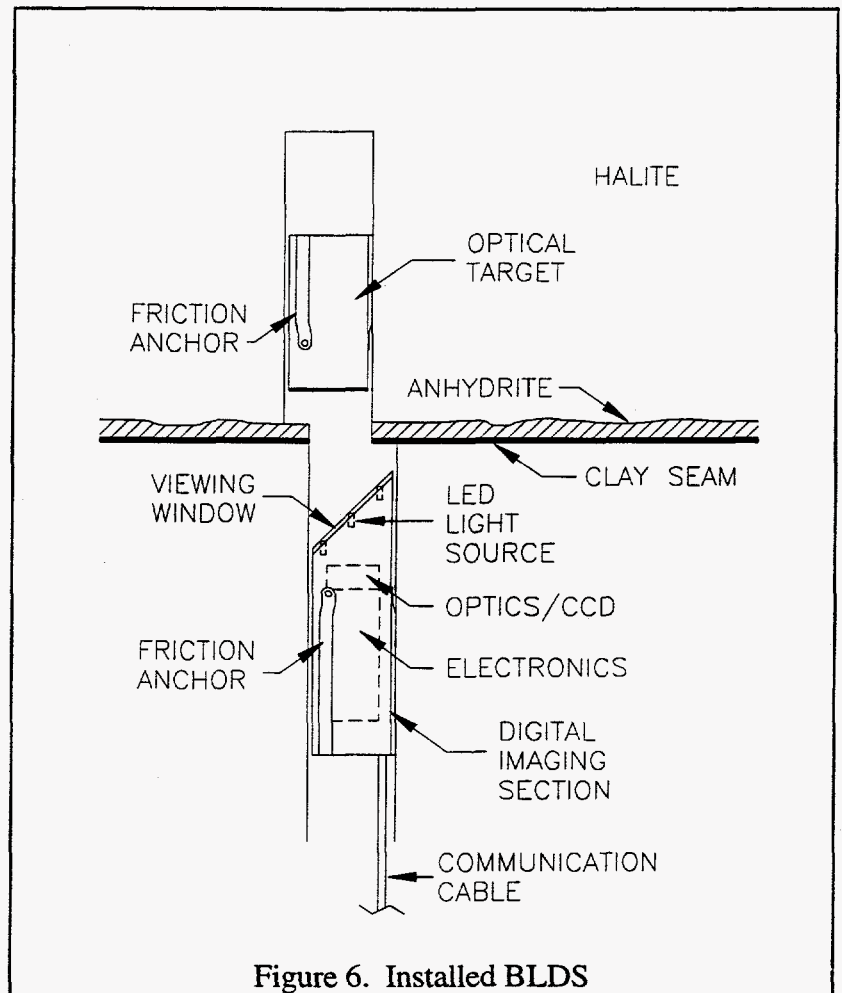

INSTALLATION

The present version of the BLDS is designed for installation in a 7.6 cm (3 inch) borehole, and is used to detect offset at clay G. Because displacement along the clay seam is ongoing in most excavations, the BLDS must be installed almost immediately after borehole drilling. The BLDS components are anchored on opposite sides of the clay seam plane (Figure 6). The components are installed simultaneously with the optical target placed beyond the plane (above the clay seam). The digital imaging section lies below the clay seam. A clear viewing window set at 45 degrees from horizontal prevents falling debris from obstructing the view of the imaging section.

OPERATION

The BLDS is connected to a portable PC and an image of the optical target is taken. The digital imaging section obtains an image of the optical target (Figure 7). Light is provided by an array of LED's located at the top of the device. The light colored circle on the optical target is an aluminum ring which has been machined with square edges to provide image sharpness. The remaining surface is covered with a black felt-like material to reduce light scattering and mirroring. The image data file is then downloaded from the device to the PC.

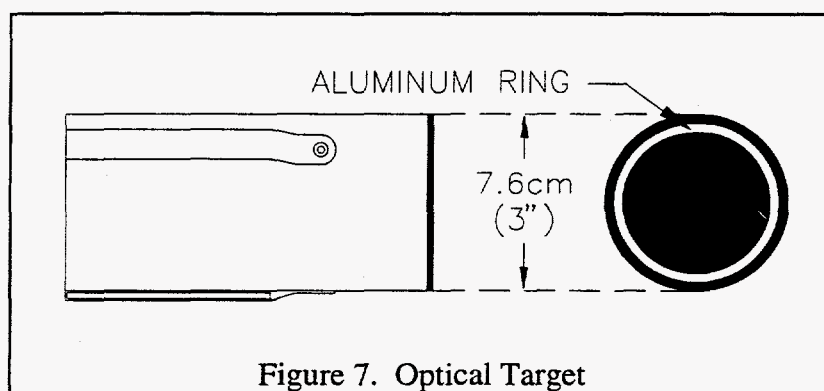

Figure 7. Optical Target

The analysis software redraws the circle (aluminum ring) as an ellipse; this is due to the aspect ratio of the CCD. The analysis software repeatedly calculates the x and y coordinates of the center of the ellipse from the random selection of 3-point sets, from which average coordinate values are obtained. Typically 2000 samples are averaged. Bench testing revealed accuracies better than) 0.076 mm (0.003 in).

Figures 8a-d show a progression of target images over time for an installation. Lateral displacement along the offset plane is increasingly obstructing one side of the ellipse. The resultant vector describes the relative displacement. In Figure 8, this relative displacement is occurring normal to the rib, although the device can measure displacement omni-directionally.

BLDS MONITORING RESULTS

The first BLDS used at WIPP was installed near the west rib of a 7.6 m (25 ft) wide drift (Figure 11) in January, 1995. The device was placed about 0.3 m (1 ft) east of an existing observation borehole (EEP37E). EEP37E was drilled in March, 1993 and displayed over 2.5 cm (1 in) displacement at clay G at the time of BLDS installation. Another observation borehole, OH207, was drilled about 1 m (3 ft) north of the BLDS, at the same time the BLDS borehole was drilled. This arrangement was chosen to observe displacements at locations inline with the BLDS, but at different distances from the rib. Table 1 shows the displacements along clay G that were visually observed in the observation boreholes and measured by BLDS1 over similar periods of time.

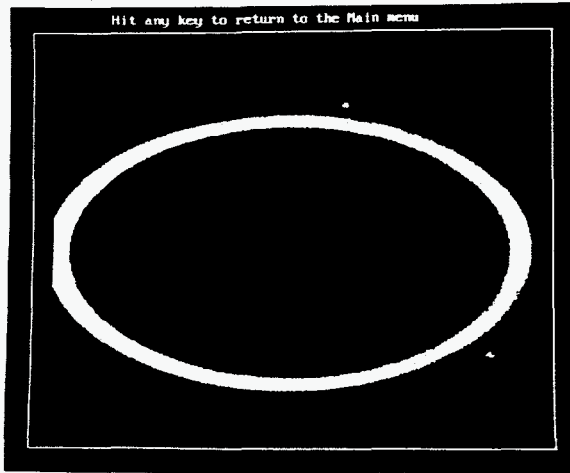

Figure 8a. BLDS1 Image Obtained January 16, 1995 (Initial)

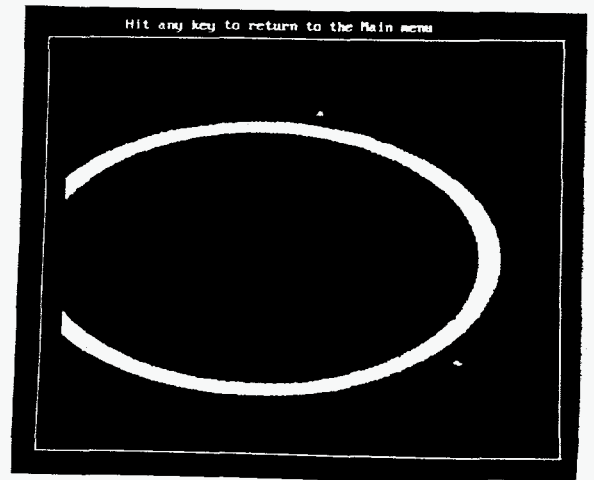

Figure 8b. BLDS1 Image Obtained May 24, 1995

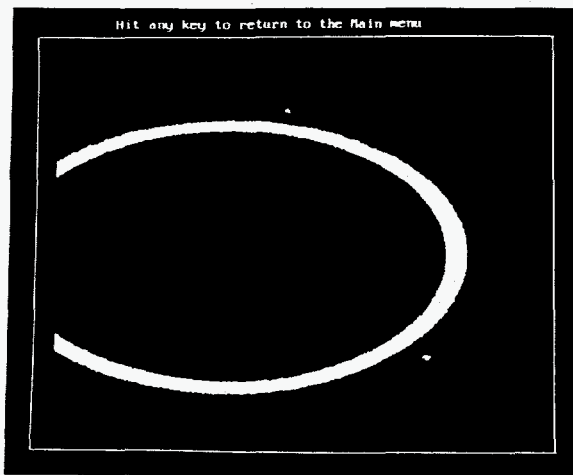

Figure 8c. BLDS1 Image Obtained August 22, 1995

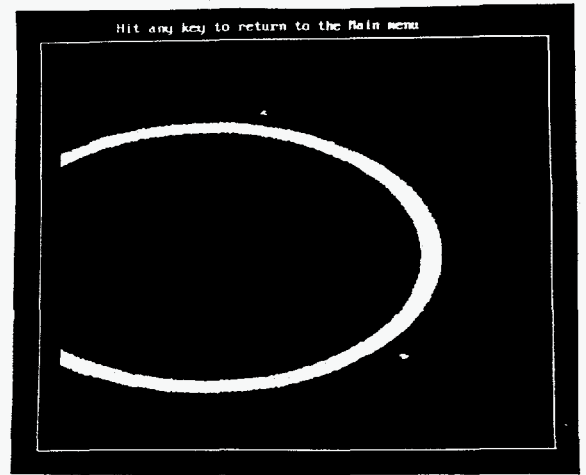

Figure 8d. BLDS1 Image Obtained November 17, 1995

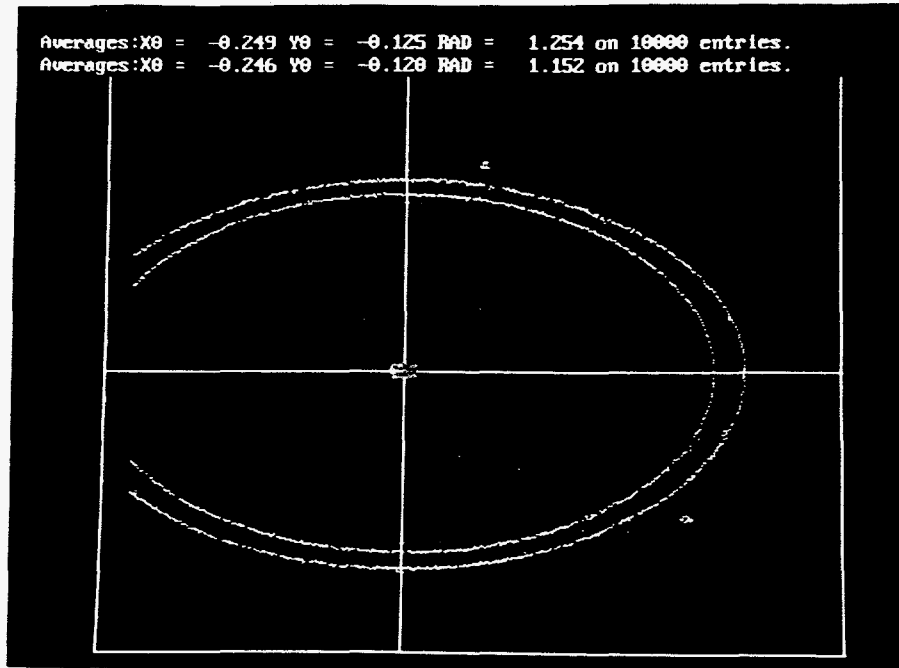

Figure 9. Ellipse in Analysis Software

BDLS2, BLDS3, and BLDS 4 were installed in November, 1995, in a 7.6 m (25 ft) wide drift (Figure 11). The installations were placed near existing observation boreholes, and arranged in a layout that would provide comparison of measurements taken at different distances from the east rib. Table 2 shows the displacements along clay G that were visually observed in the observation boreholes and measured by the BLDS's over similar periods of time.

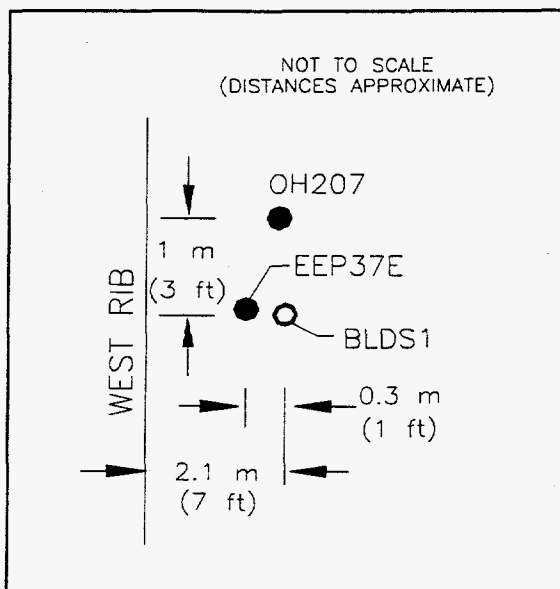

Figure 10. E300 Shop

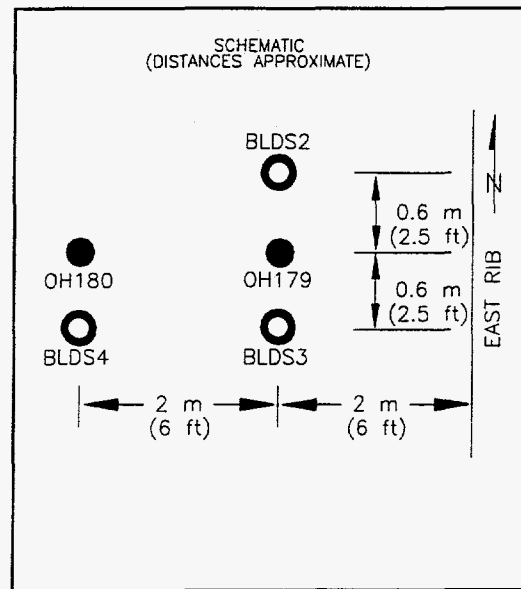

Figure 11. E140, N620

Table 1 - Lateral Displacement Measurements at E300, N45

Borehole ID	Elapsed Time Between Readings (days)	Relative Displacement along clay G	Direction of Roof Beam Movement	Reading Interval
EEP37E	208	6 mm (0.25 in)	E	Dec. 21, 1994 to July 17, 1995
BLDS1	183	8.3 mm (0.33 in)	E	Jan. 16, 1995 to July 18, 1995
OH207	193	10 mm (0.38 in)	E	Jan. 5, 1995 to July 17, 1995

Table 2 - Lateral Displacement Measurements at E140, N620

Borehole ID	Elapsed Time Between Readings (days)	Relative Displacement along clay G	Direction of Roof Beam Movement	Reading Interval
OH179	89	3.3 mm (0.13 in)	W	Dec. 28, 1995 to Mar. 26, 1996
BLDS2	84	6.1 mm (0.24 in)	W7°S	Jan. 2, 1996 to Mar. 26, 1996
BLDS3	84	7.1 mm (0.28 in)	W8°S	Jan. 2, 1996 to Mar. 26, 1996
BLDS4	Removed due to deteriorating borehole conditions below clay G.			

BLDS5, BLDS6, and BLDS7 were also installed in November, 1995, at a location approximately 24.4 m (80 feet) south of the previous three (Figure 12). The drift width is 7.6 m (25 ft). The devices are also arranged in a layout that allows comparison of measurements taken at different distances from the east rib. No existing observation boreholes had been drilled nearby, therefore one (OH215) was drilled at the same time as the BLDS boreholes. Table 3 shows the displacements along clay G that were visually observed in the OH215 and measured by the BLDS's over similar periods of time. The relative displacement recorded by BLDS6 (located at drift center) is somewhat lower than that measured by the devices located nearer the rib. This is expected to continue to hold true based on the typical roof deformation pattern discussed earlier.

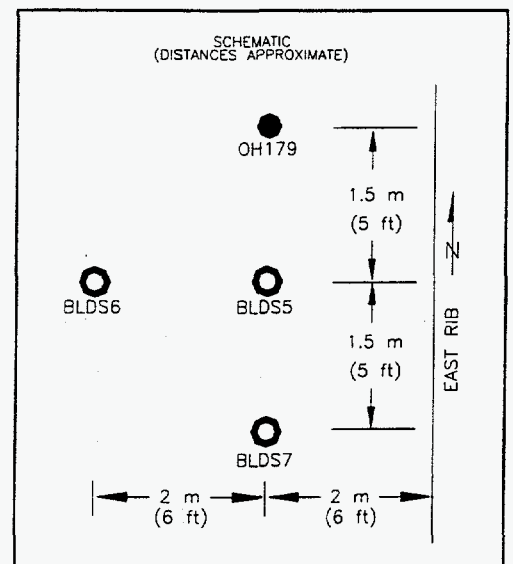

Figure 12. E140, N540

Table 3 - Lateral Displacement Measurements at E140, N520

Borehole ID	Elapsed Time Between Readings (days)	Relative Displacement along clay G	Direction of Roof Beam Movement	Reading Interval
OH215	127	10 mm (0.38 in)	W	Nov. 20, 1995 to Mar. 26, 1996
BLDS5	126	7.8 mm (0.31 in)	W20°S	Nov. 21, 1995 to Mar. 26, 1996
BLDS7	126	7.6 mm (0.30 in)	W27°S	Nov. 21, 1995 to Mar. 26, 1996
BLDS6	126	6.1 mm (0.24 in)	W28°S	Nov. 21, 1995 to Mar. 26, 1996

SUMMARY AND PLANS FOR FUTURE USE

The Borehole Lateral Displacement Sensor has demonstrated the capability of electronically quantifying both magnitude and direction of lateral displacement occurring along clay seams in WIPP excavations. In cases of remote monitoring of roof conditions, the BLDS can compliment geomechanical data by providing the direction and magnitude of lateral rock displacement. BLDS devices were installed in SPDV Room 4 (Figure 3) in December, 1995, to remotely monitor roof beam displacement after access to the SPDV area is prohibited. Displacement along clay G in this room has been monitored continuously in observation boreholes since 1986. To date, the BLDS devices are obtaining magnitudes and directions of displacement as expected based on the trends seen in the previous observations.

Plans are in progress to install BLDS devices in a drift in which the immediate roof beam is to be removed. The devices will be installed across a clay seam to monitor minute changes in displacement expected to occur as a result of the roof beam removal. Other plans are being made to utilize BLDS and extensometer data to evaluate the relationship (if any) between roof beam expansion and lateral displacement, as well as relationships between of lateral displacement and stress distribution.

REFERENCES

Francke, C.T., and Terrill, L.J., "The Excavation Effects Program at the Waste Isolation Pilot Plant", Innovative Mine Design for the 21st Century, proceedings of the International Congress on Mine Design, Balkema.

Terrill, L.J., et al, "Analysis of Rockbolt Performance at the Waste Isolation Pilot Plant", proceedings of Fourteenth International Conference on Ground Control in Mining, West Virginia University.

Processing and final preparation of this report was performed by the Waste Isolation Pilot Plant Management and Operating Contractor for the U.S. Department of Energy under Contract No. DE-AC04-86AL31950.