

CONF-9605201--4

**ERNEST ORLANDO LAWRENCE  
BERKELEY NATIONAL LABORATORY**

**High-Resolution VUV Spectroscopy:  
New Results from the Advanced  
Light Source**

F. Schlachter and J. Bozek  
**Accelerator and Fusion  
Research Division**

**RECEIVED  
SEP 20 1996  
OSTI**

June 1996  
Presented at the  
*Workshop on Atomic Physics with  
Hard X Rays from High Brilliance  
Synchrotron Light Sources,*  
Argonne, IL,  
May 20-21, 1996,  
and to be published in  
the Proceedings

DISTRIBUTION OF THIS DOCUMENT IS UNLIMITED

**MASTER**

#### DISCLAIMER

This document was prepared as an account of work sponsored by the United States Government. While this document is believed to contain correct information, neither the United States Government nor any agency thereof, nor The Regents of the University of California, nor any of their employees, makes any warranty, express or implied, or assumes any legal responsibility for the accuracy, completeness, or usefulness of any information, apparatus, product, or process disclosed, or represents that its use would not infringe privately owned rights. Reference herein to any specific commercial product, process, or service by its trade name, trademark, manufacturer, or otherwise, does not necessarily constitute or imply its endorsement, recommendation, or favoring by the United States Government or any agency thereof, or The Regents of the University of California. The views and opinions of authors expressed herein do not necessarily state or reflect those of the United States Government or any agency thereof, or The Regents of the University of California.

Ernest Orlando Lawrence Berkeley National Laboratory  
is an equal opportunity employer.

# High-Resolution VUV Spectroscopy: New Results from the Advanced Light Source\*

Fred Schlachter and John Bozek

Advanced Light Source  
Lawrence Berkeley National Laboratory  
Berkeley, CA 94720

June 1996

This paper was presented at the Workshop on Atomic Physics With Hard X Rays  
from High Brilliance Synchrotron Light Sources,  
Argonne National Laboratory,  
May 20–21, 1996

\*This work was supported by the Director, Office of Energy Research, Office of Basic Energy Sciences, Materials Sciences Division, of the U. S. Department of Energy, under Contract No. DE-AC03-76SF00098



Recycled Paper

**DISCLAIMER**

**Portions of this document may be illegible in electronic image products. Images are produced from the best available original document.**

## High-Resolution VUV Spectroscopy: New Results from the Advanced Light Source\*

Fred Schlachter and John Bozek

Advanced Light Source  
Lawrence Berkeley National Laboratory  
Berkeley CA 94720

Third-generation synchrotron light sources are providing photon beams of unprecedented brightness for researchers in atomic and molecular physics. Beamline 9.0.1, an undulator beamline at the Advanced Light Source (ALS), produces a beam in the vacuum-ultraviolet (VUV) region of the spectrum with exceptional flux and spectral resolution. Exciting new results from experiments in atomic and molecular VUV spectroscopy of doubly excited autoionizing states of helium, hollow lithium, and photoelectron spectroscopy of small molecules using Beamline 9.0.1 at the ALS are reported.

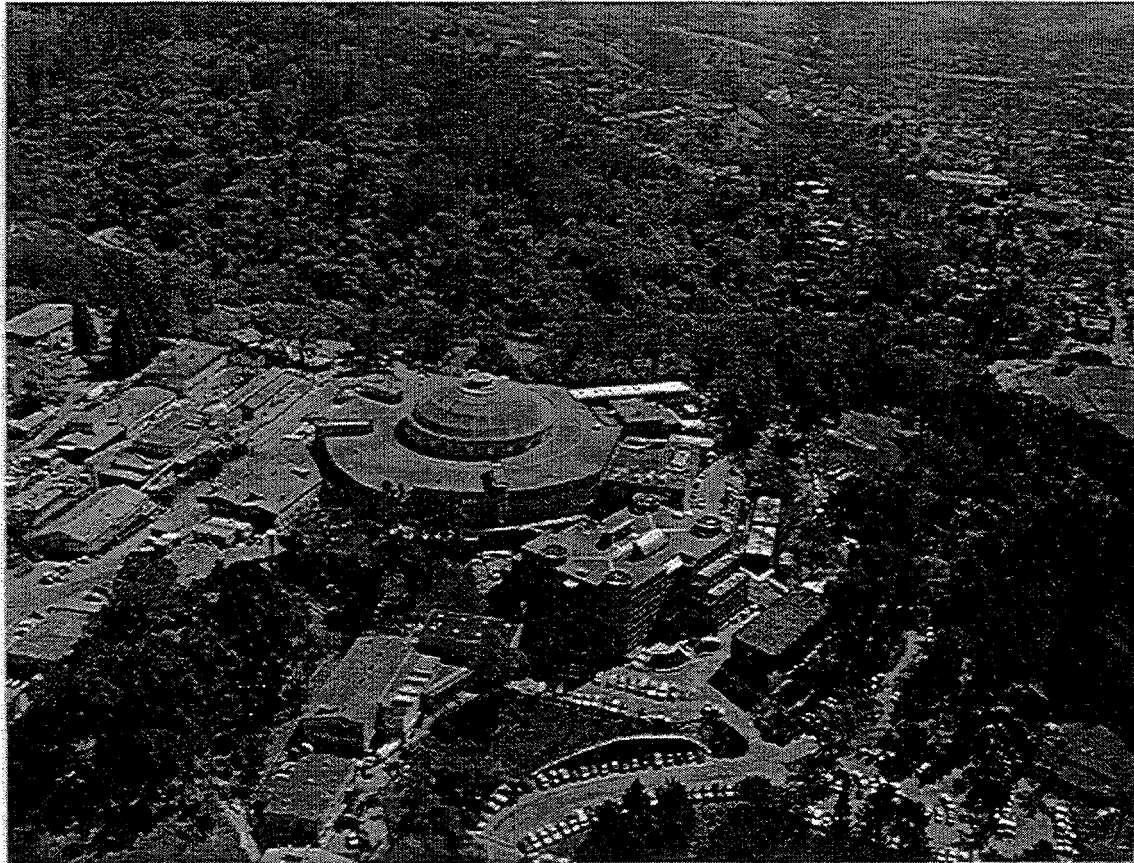

Figure 1. The Advanced Light Source at Lawrence Berkeley National Laboratory produces America's brightest light in the ultraviolet through soft x-ray range. Researchers from around the world use this facility to conduct experiments in everything from materials science and protein crystallography to atomic and molecular physics.

\*This work was supported by the Director, Office of Energy Research, Office of Basic Energy Sciences, Materials Sciences Division, of the U. S. Department of Energy, under Contract No. DE-AC03-76SF00098

## Overview

The ALS is one of the first third-generation light sources producing high-brightness x rays for user research. Several undulator beamlines using spherical-grating monochromators produce photon beams of exceptional flux and spectral resolution. Beamline 9.0.1 utilizes a 10-cm-period undulator (8-cm-period prior to 1996) to produce a high-brightness beam of radiation which is monochromatized with a spherical-grating monochromator using one of three water-cooled gratings. This beamline was designed to produce intense photon beams with a resolving power ( $E/\Delta E$ ) of 10,000 [1]. Characterization of this beamline found the flux to be approximately  $10^{12}$  photons per second with the design resolving power over the energy range 20–300 eV [2].

Excellent design and fabrication of the beamline and optics, and careful attention to operating conditions have allowed a resolving power of 64,000 (1 meV at 64 eV) to be obtained—significantly exceeding the design requirements [3, 4]. This resolution, a factor of four better than previously achieved in this energy range, coupled with the very high flux of the beamline, have allowed unique results to be obtained. These results are described in the following pages.

The ultimate resolving power of the beamline using the 925 lines/mm grating is about 160,000 as determined by the number of grooves on the grating. Factors which degrade the theoretical resolution of the experimentally obtained values include the finite entrance and exit slits (typically in the range 2–20  $\mu\text{m}$ ), the coma aberration, figure errors of the optical surfaces, and the stability of the mechanical and optical systems of the beamline. The coma error is very small at 64 eV, because the Rowland-circle condition is nearly fulfilled for this energy. The excellent resolving power achieved shows that the optical quality of the grating is excellent, with a figure error better than 0.5  $\mu\text{rad}$  rms [5].

The following pages provide information about high brightness, third-generation light sources, and Beamline 9.0.1 at the ALS. Examples of recent results obtained in atomic and molecular physics using undulator Beamline 9.0.1 are also presented.

## References

- [1] P. Heimann, Advanced Light Source Note LSBL-110 (1991); P.A. Heimann, T. Warwick, M.R. Howells, W. McKinney, R. Di Gennaro, B. Gee, D. Yee, and B. Kincaid, Nucl. Instr. Meth. A319, 106 (1992).
- [2] Phil Heimann, Dmitri Mossessian, and John Bozek, Advanced Light Source Note LSBL-239 (1995).
- [3] J.D. Bozek, P.A. Heimann, A.S. Schlachter, G. Kaindl, and K. Schulz, in Atomic and Molecular Photoionization, Proceedings of the Oji International Seminar on Atomic and Molecular Physics, pp. 243–242 (1996).
- [4] K. Schulz, G. Kaindl, M. Domke, J.D. Bozek, P.A. Heimann, and A.S. Schlachter, submitted for publication (1996).
- [5] G. Kaindl, K. Schultz, P.A. Heimann, J.D. Bozek, and A.S. Schlachter, Synchr. Rad. News 8 (5), 29 (1995).

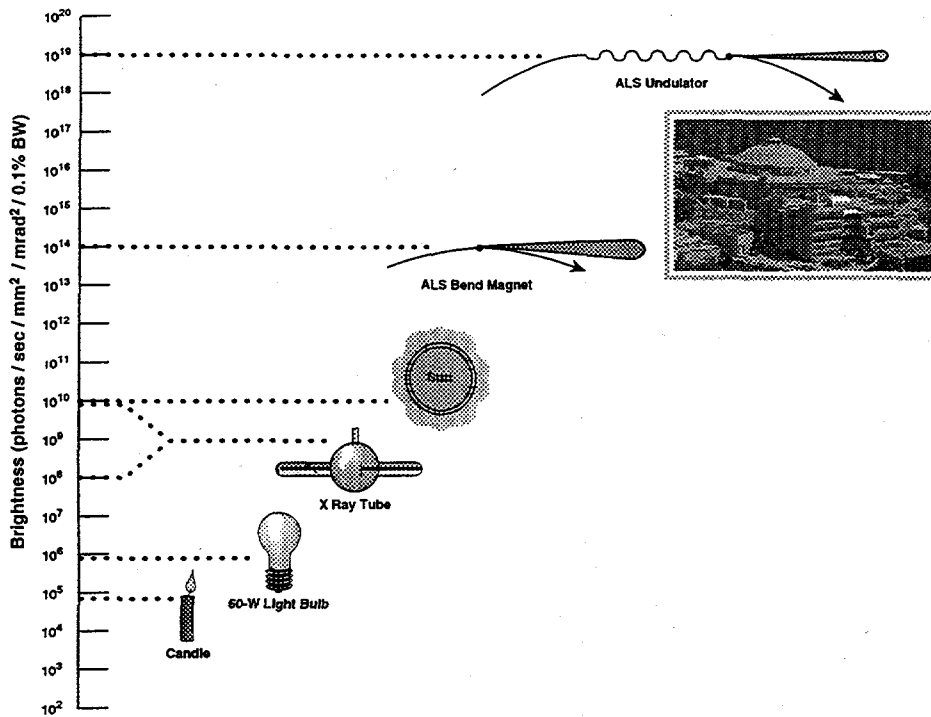

Figure 2. The x rays produced from ALS undulators are many orders of magnitude brighter than the sun or an x-ray tube, and several orders of magnitude brighter than those emitted from bend magnets of second-generation light sources.

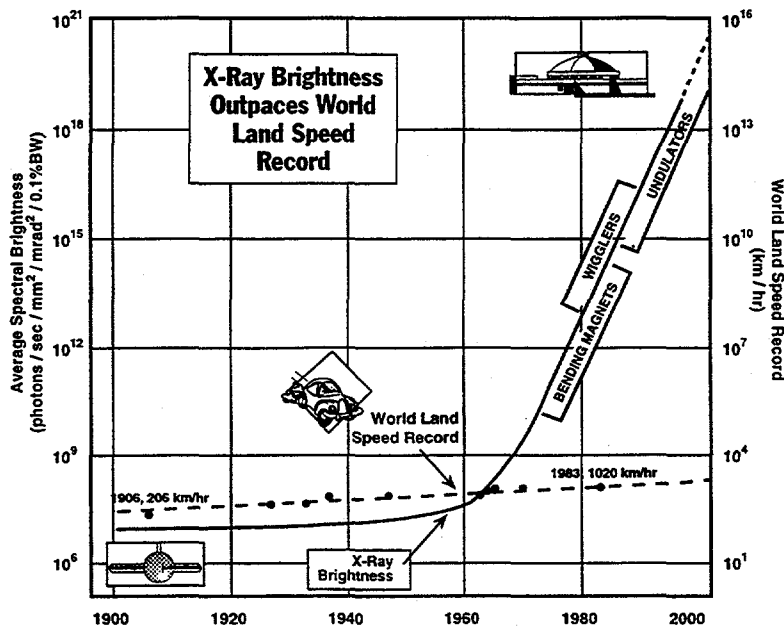

Figure 3. X-ray brightness has increased dramatically since the early 1960's; if the land speed record had kept pace with this increase, cars would now travel nearly one million times the speed of light ( $10^{15}$  km/hr).



	Ring	Energy
<b>OPERATIONAL</b>		
FRANCE, Grenoble	ESRF	6.0
ITALY, Trieste	ELETTRA	1.5-2.0
KOREA, Pohang	PLS	2.0
SWEDEN, Lunc	MAX II	1.5
TAIWAN, Hsinchu	SRRC	1.3
USA, Berkeley	ALS	1.5
USA, Argonne	APS	7.0
<b>SOON TO BE OPERATIONAL</b>		
GERMANY, Berlin	BESSY II	1.5-2.0
JAPAN, Nishi Harima	SPring-8	8.0
<b>PLANNED</b>		
BRAZIL, Campinas	LNLS-2	2.0
CANADA, Saskatoon		2.5
CHINA, Shanghai	SSRF	2.0-2.5
ENGLAND, Daresbury	SINBAD	0.6
	Diamond	3.0
FRANCE, (TBA)	SOLEIL	2.2
INDIA, Indore	INDUS-II	2.0
JAPAN, Ichihara	Nanohana	2.5
Kashiwa	ISSP	2.0
SPAIN, Barcelona	Catalonia SR	2.5
SWITZERLAND, (TBA)	SLS	1.5-2.1
UKRAINE, Kiev	ISI-800	0.8

Figure 4. High-energy (6-8 GeV) and low-energy (less than 2.5 GeV) third-generation light sources are in the planning, construction or operational stages in many parts of the world.

### Bend-Magnet Radiation

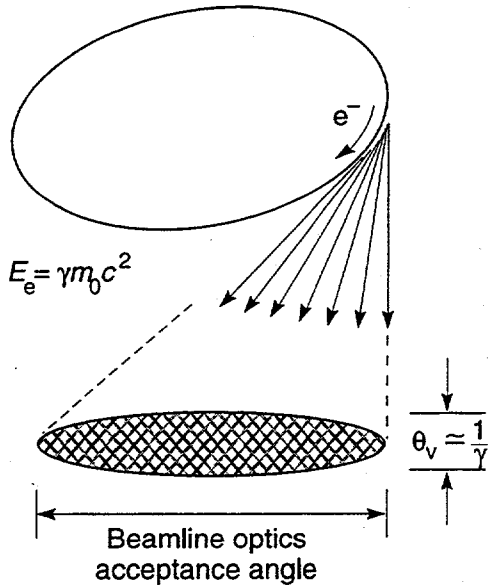

### Undulator Radiation

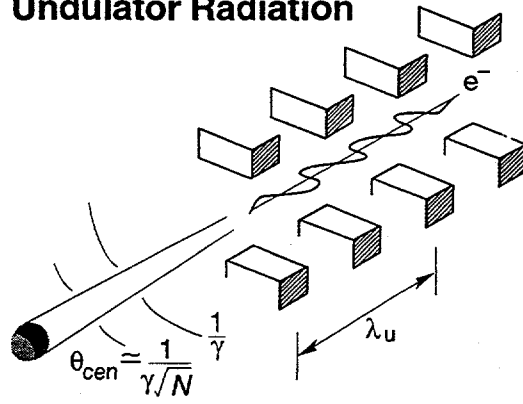

$$\lambda_x = \frac{\lambda_u}{2\gamma^2} \left( 1 + \frac{K^2}{2} + \gamma^2 \theta^2 \right)$$

In the central radiation cone:

$$\frac{\Delta\omega}{\omega} \approx \frac{1}{N}$$

$$\theta_{cen} \approx \frac{1}{\gamma N}$$

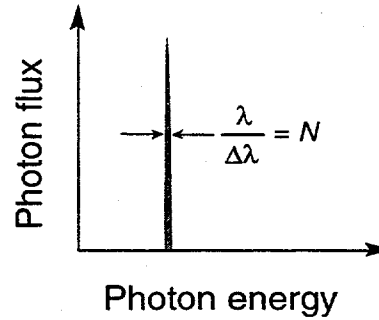
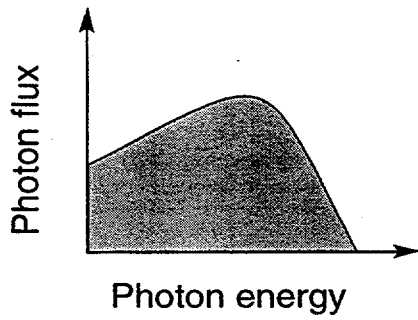
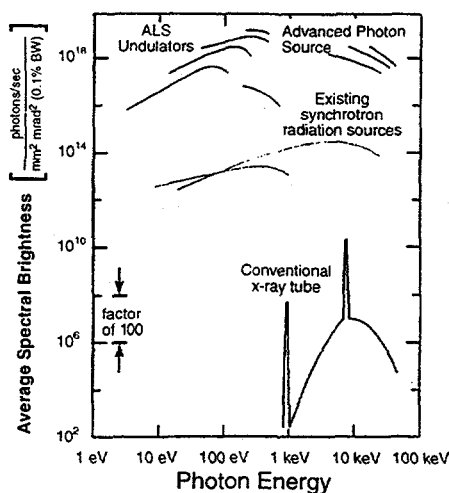

Figure 5. Synchrotron light sources produce photon beams from bend magnets, undulators and wigglers. Radiation emitted from an undulator is spatially contained in a narrow cone, producing an extremely bright and essentially monochromatic (with harmonics) photon beam.



- Very high brightness in the ultraviolet and soft x-ray region
  - High spectral resolution (~10,000)
  - High spatial resolution (50  $\mu\text{m}$  – 500  $\text{\AA}$ )
- High flux
- Variable polarization
  - Linear
  - Circular
- Partial coherence
- Tunable over a wide energy range (< 10 eV to > 10 keV)
- Short pulse (~35 ps @ 500 MHz)

Figure 6. The characteristics of the radiation produced at the ALS make it an exceptional tool for new research in the fields of atomic and molecular physics. Radiation emitted from high- and low-energy third-generation light sources cover a wide range of photon energies and offer many research possibilities.

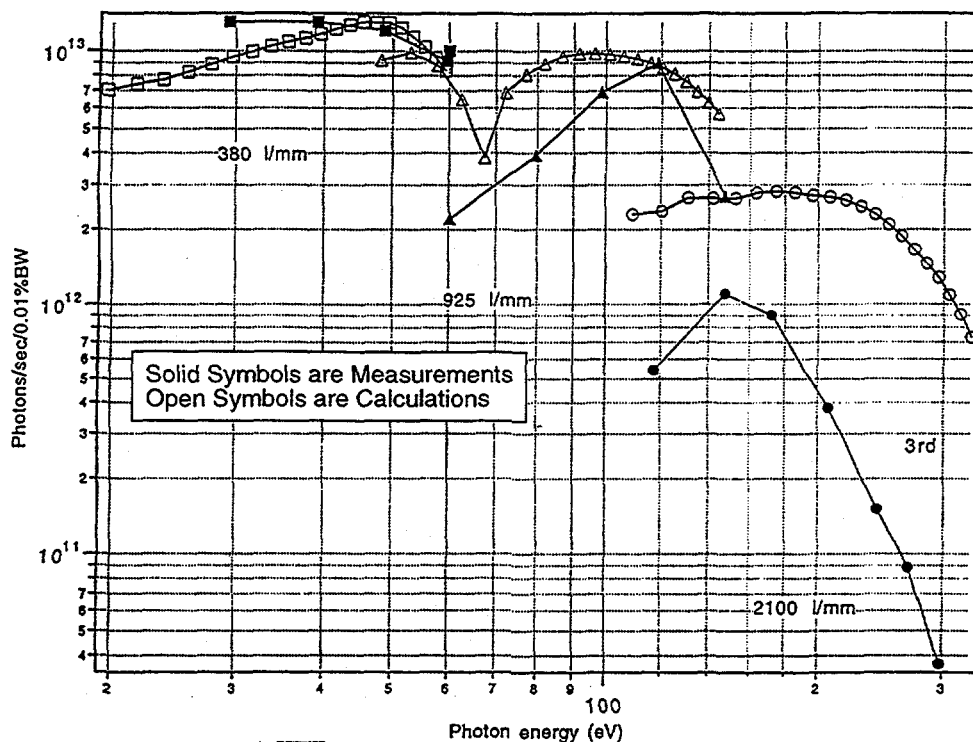

Figure 7. High photon flux is obtained on Beamline 9.0.1 using three gratings. With the exception of the 2100 line/mm grating, this system performs to design expectations. (Heimann, Mossessian, and Bozek, LSBL-239, 1995).

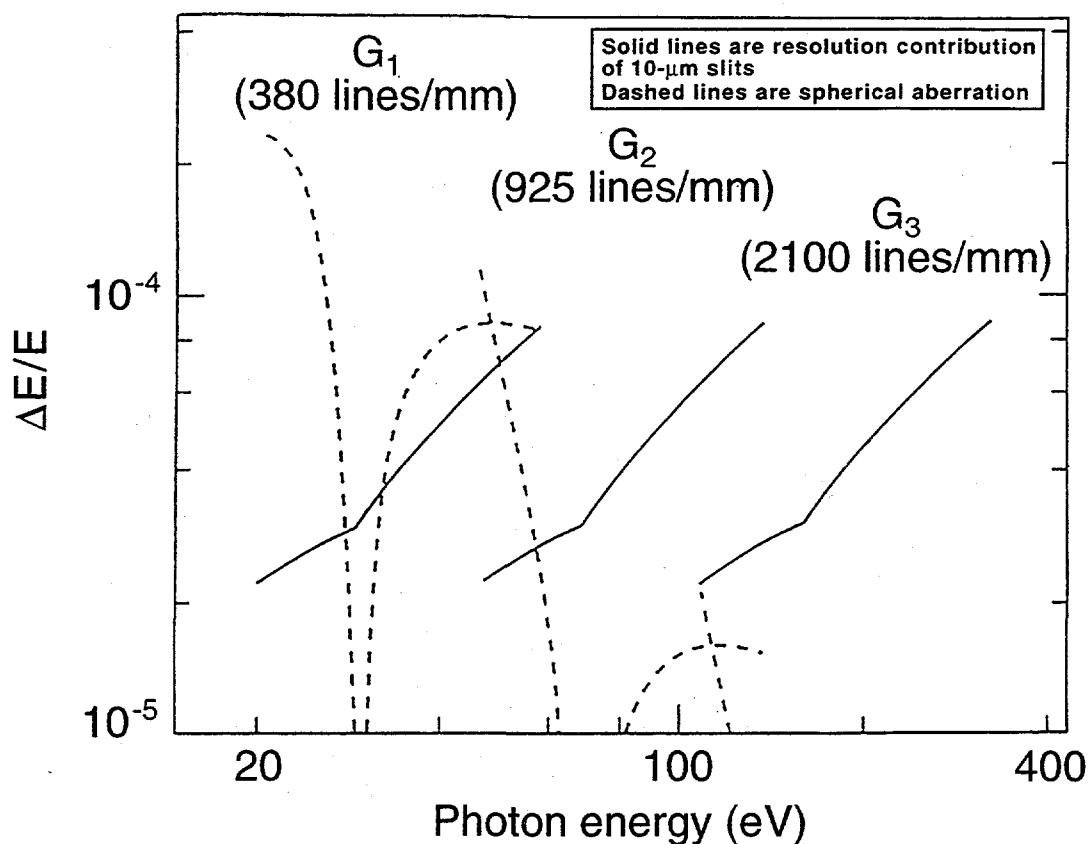

Figure 8. A resolving power of 10,000 or more is calculated in the 20–300 eV energy range on Beamline 9.0.1 (Heimann, Mossessian, and Bozek, LSBL-239, 1995). Sources of limitation to resolving power include spherical aberration, the contribution of the finite slit widths, optical finish of the grating, mechanical vibration, and the total number of illuminated grooves on the grating.

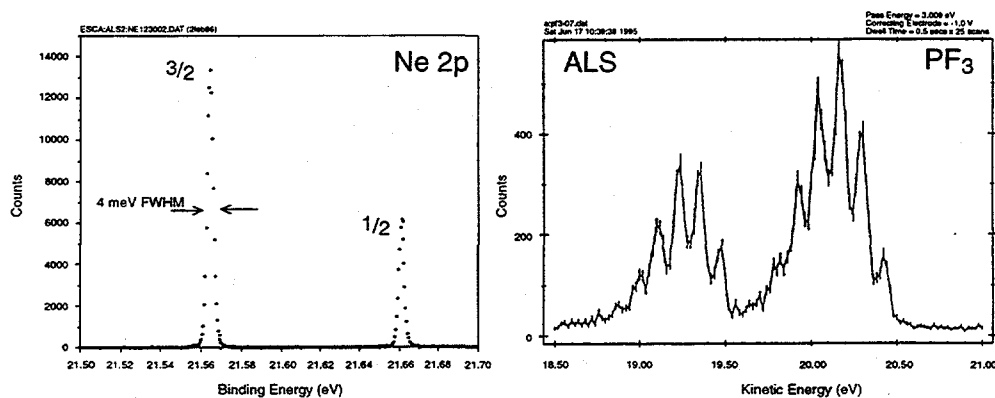

Figure 9. Beamline 9.0.1 at the ALS provides an opportunity for a new look at atoms and molecules using the exceptional photon energy resolution. [Ultra-high resolution spectroscopy of Ne 2p using Baltzer's electron spectrometer; Baltzer and Bozek, (1996); vibrational and ligand-field splitting of core-level photoelectron lines, Bozek, Schlachter, Lubell, Morgan, and Cisneros, (1995).]

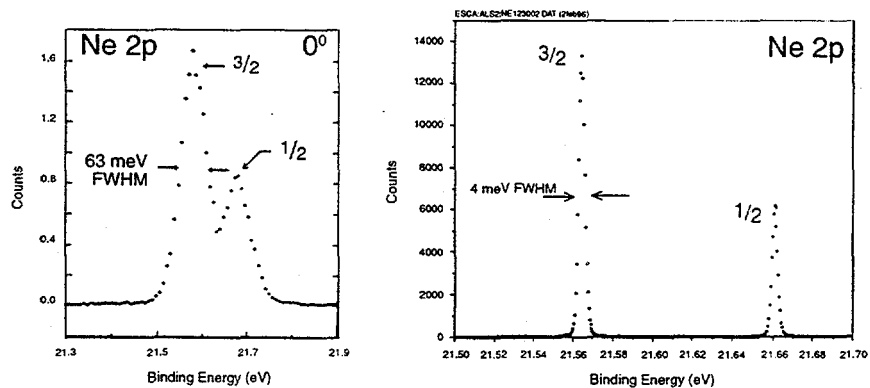

Figure 10. Photoemission from neon 2p level, demonstrating excellent photon and electron energy resolution possible at the ALS. (1992 spectrum from J. Krause et al., 1996 ALS spectrum obtained using ALS Beamline 9.0.1 and P. Baltzer's electron spectrometer; measurement by P. Baltzer and J.D. Bozek.)

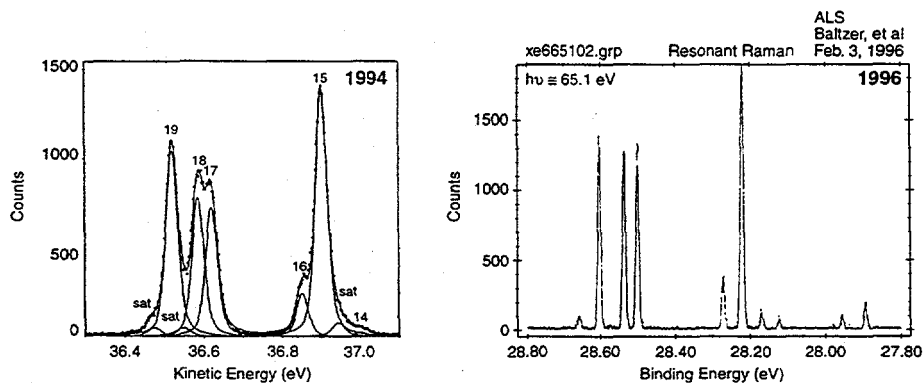

Figure 11. Photoemission from xenon showing the  $4d^{-1}6p \rightarrow 5p^{-2}6p$  Auger resonant Raman transition. (1994 spectrum from Akesela et al., 1996 ALS spectrum obtained using ALS Beamline 9.0.1 and Peter Baltzer's electron spectrometer; measurement by P. Baltzer and J.D. Bozek.)

Canadian Grashopper at  
Canadian Synchrotron Radiation Facility  
Synchrotron Radiation Center (Aladdin)  
Madison, WI

$h\nu = 160 \text{ eV}$

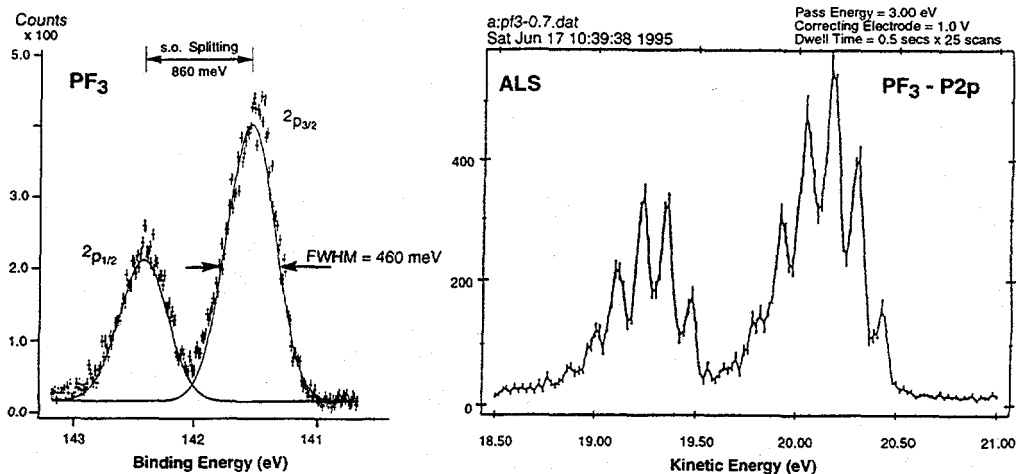

Figure 12. Photoemission from  $\text{PF}_3$  showing fine structure splitting and (ALS spectrum only vibrational) ligand-field splitting. (Canadian Grashopper spectrum courtesy of Ron Cavell; ALS spectrum obtained by Bozek, et al., 1995.)

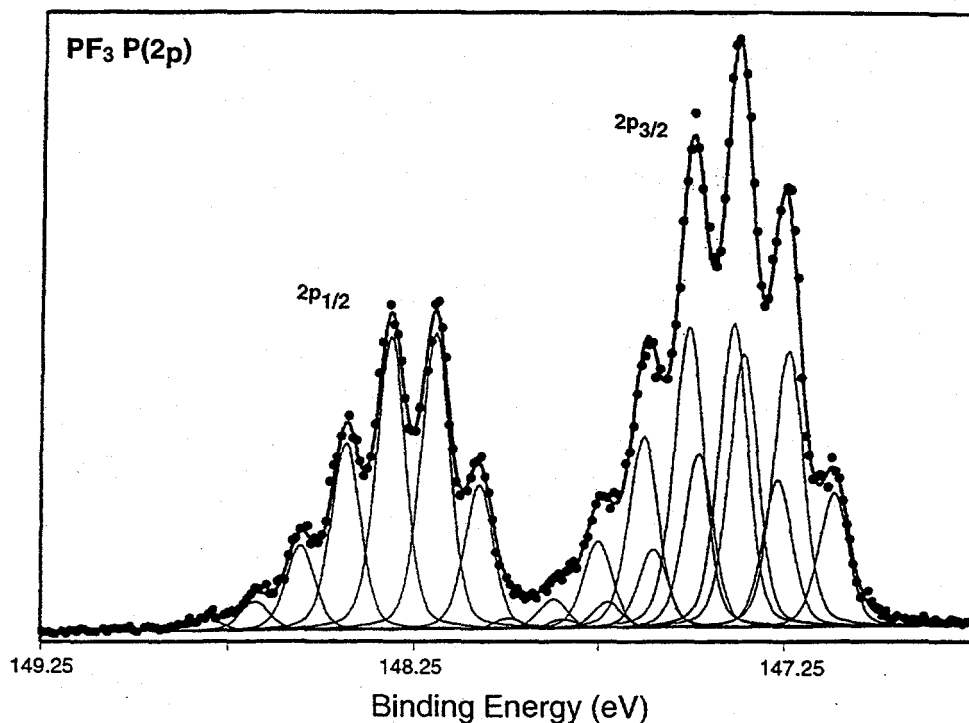

Figure 13. Photoemission from  $\text{PF}_3$  showing vibrational and ligand-field splitting. (Bozek et al., 1995.)

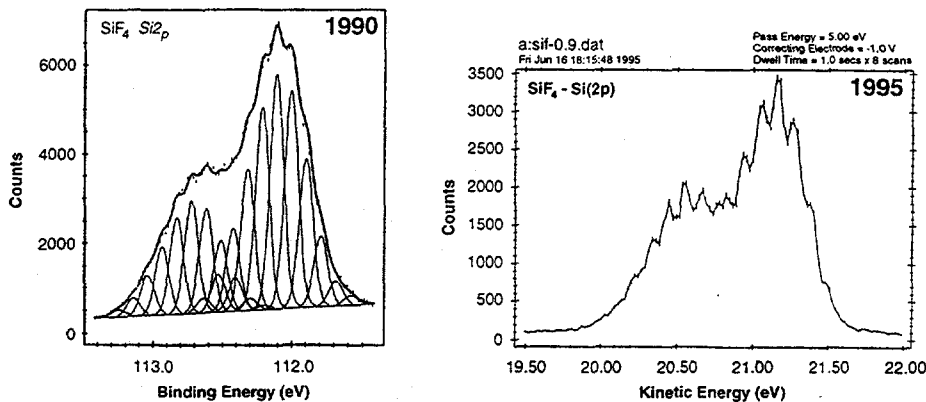

Figure 14. Photoemission from  $\text{SiF}_4$  showing fine structure splitting and vibrational splitting. (1990 spectrum from Bozek et al.; 1995 ALS spectrum from Bozek et al.)

## Doubly Excited Autoionizing States of Helium: "Hollow Helium" ALS

A prototypical two-electron system for the study of electron-electron correlation.

- Pioneering work of Madden and Codling (1963) and Cooper et al. (1963).
- Only minor progress for 30 years awaiting development of high-resolution monochromators in the soft-x-ray spectral range.
- **SX-700 at BESSY (PGM): Domke et al. (1991–6).**
  - Resolving power of 16,000 ( $E/\Delta E$ ) with low flux.
- Striking improvement in resolving power: **BL 9.0.1 at ALS (1996–6).**
  - Resolving power as high as 64,000 with low flux, 10,000 with very high flux.
- Spectral features as narrow as a few  $\mu\text{eV}$  allow optimization of beamline.
- **New Rydberg series and resonances observed.**
  - All three series converging to  $I_2$ .
  - Four out of five converging to  $I_3$ .
- Excellent agreement with theory.

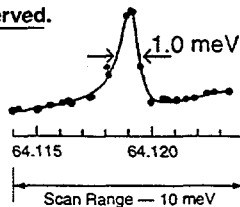

Figure 15. Doubly excited autoionizing states of helium are a prototypical two-electron system. The high degree of electron correlation leads to a very complicated spectrum. The ultra-high resolving power of Beamline 9.0.1 allows very small spectral features to be observed.

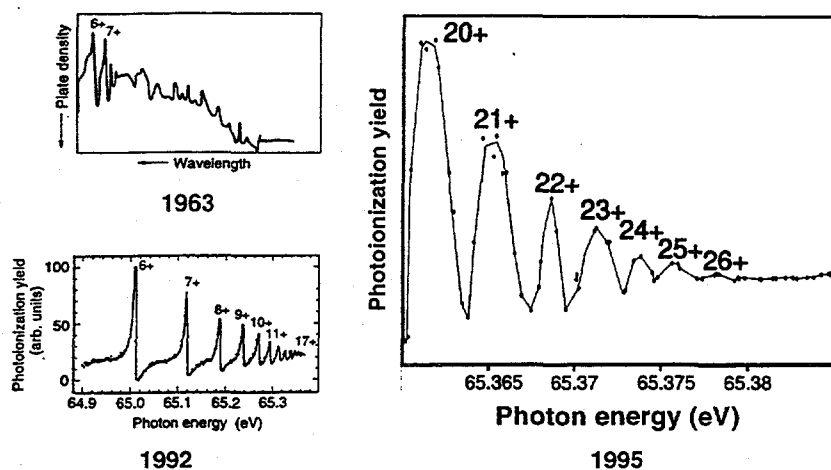

Figure 16. Photoionization yield measurements of doubly excited autoionizing states of helium showing improved performance going from first- to third-generation light sources. Increasing spectral resolution allows ever-smaller spectral features to be observed. (1963 spectrum from Madden and Codling; 1992 spectrum from Reich et al.; 1995 spectrum from Schulz, Kaindl, Domke, Bozek, Heimann, and Schlachter.)

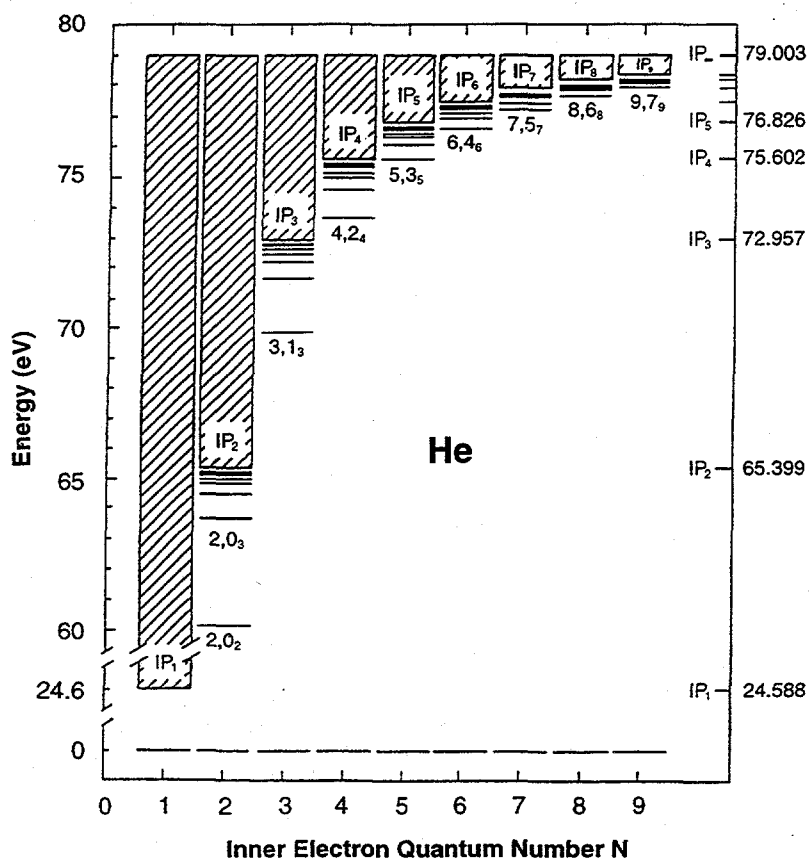

Figure 17. Energy levels of helium showing doubly excited states. Increased electron correlation in these doubly excited states and the overlap of bound states with continuum states results in a complicated spectrum.



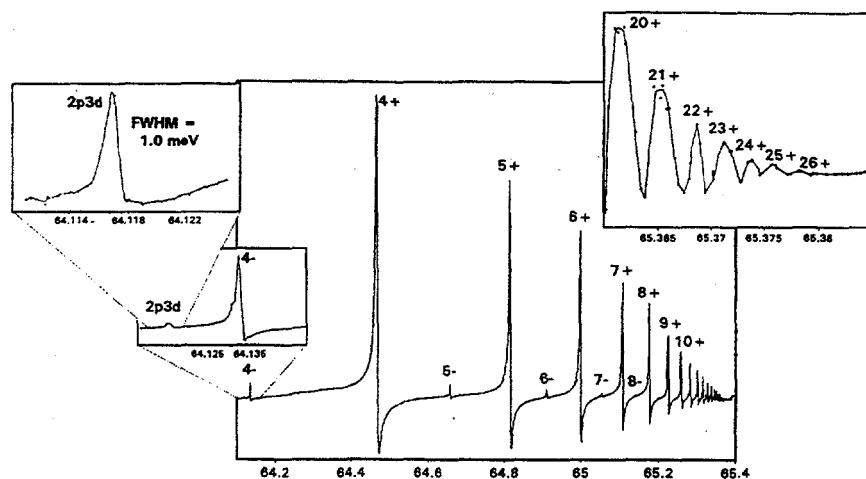

Figure 18. Photoionization yield measurements of doubly excited autoionizing states of helium. A resolution of 1 meV at 64 eV is obtained for the very narrow (few  $\mu\text{eV}$ )  $2p3d$  ( $2,-1,$ ) state. (Schulz et al., 1996.)

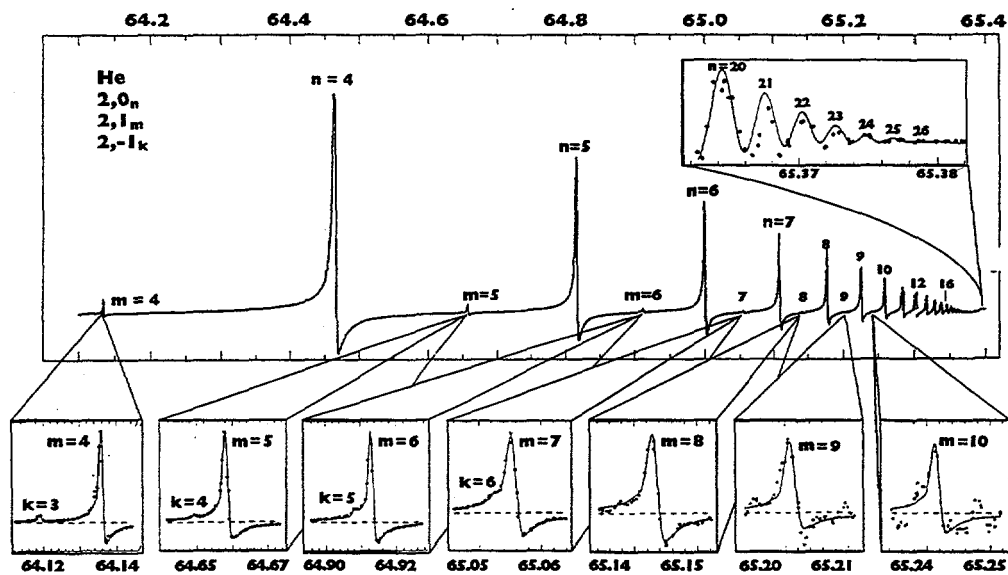

Figure 19. Photoionization yield in helium:  $n=2$  series. (Schulz et al., 1996.)

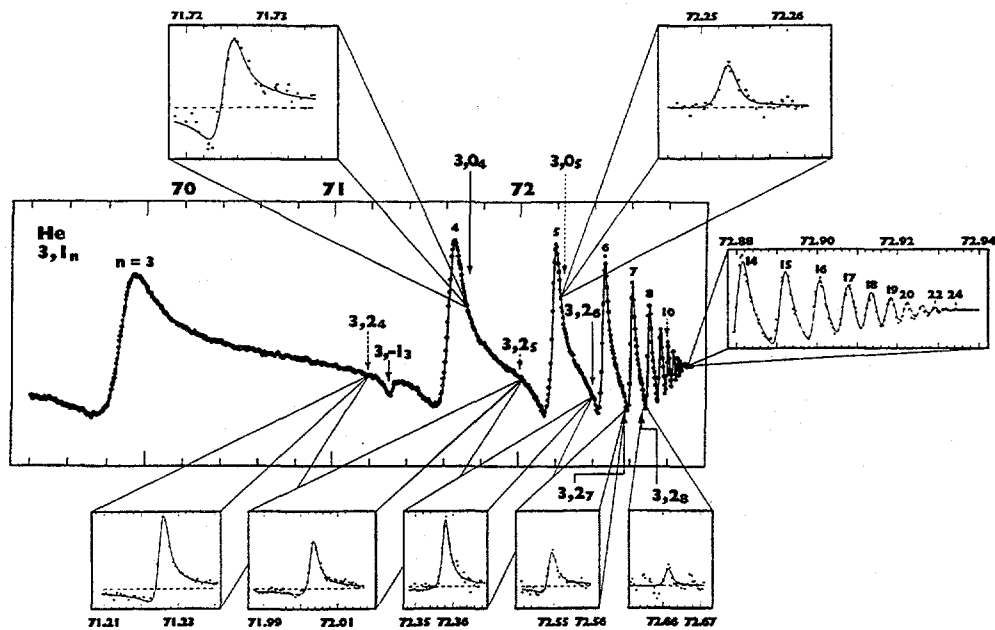

Figure 20. Photoionization in helium:  $n=3$  series. Many resonances are observed for the first time. (Schulz et al., 1996.)

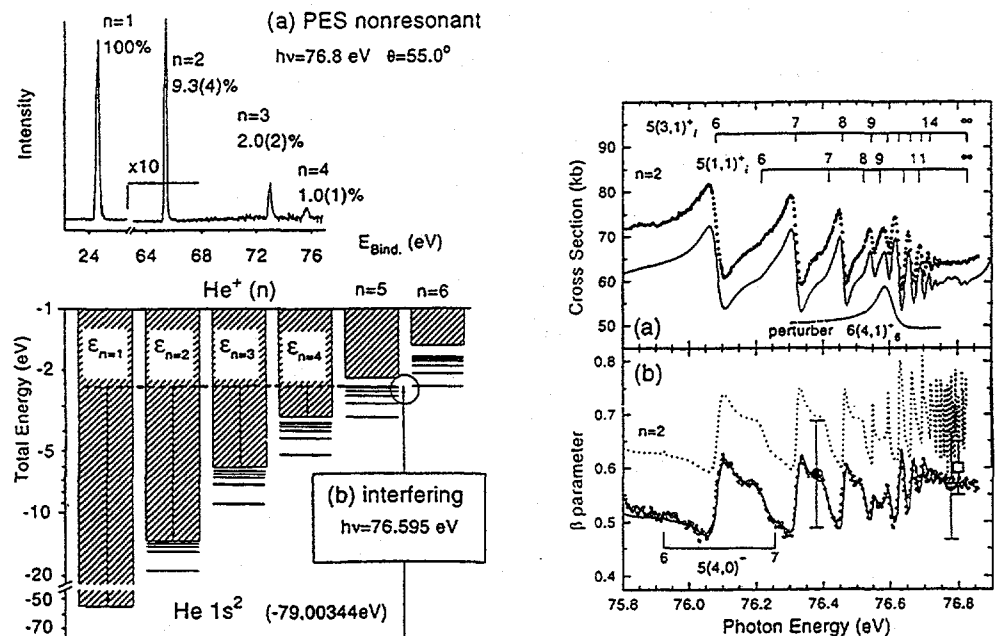

Figure 21. Photoelectron emission in helium, showing partial cross sections and asymmetry parameter in the region of interfering resonances. [Spectra obtained on ALS Beamline 9.0.1 by Menzel et al., PRL 75, 1479 (1995)].

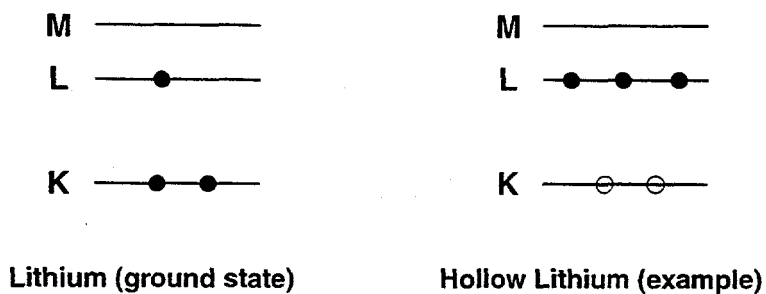

Figure 22. Hollow lithium (triply excited lithium with an empty K shell) is the prototypical three-electron system for the study of electron correlation.

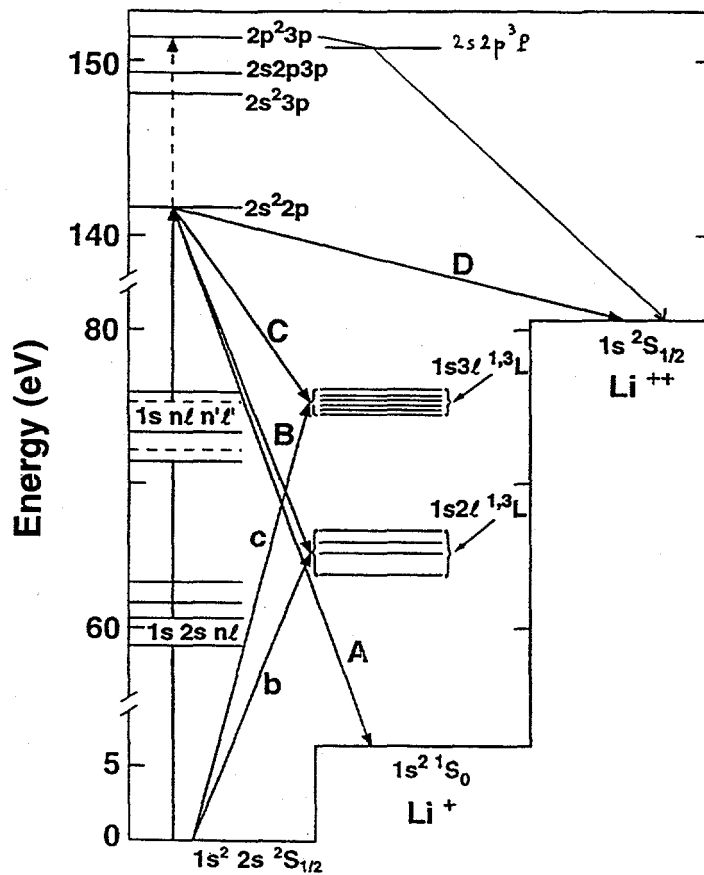

Figure 23. Energy levels of lithium showing multiply excited states.

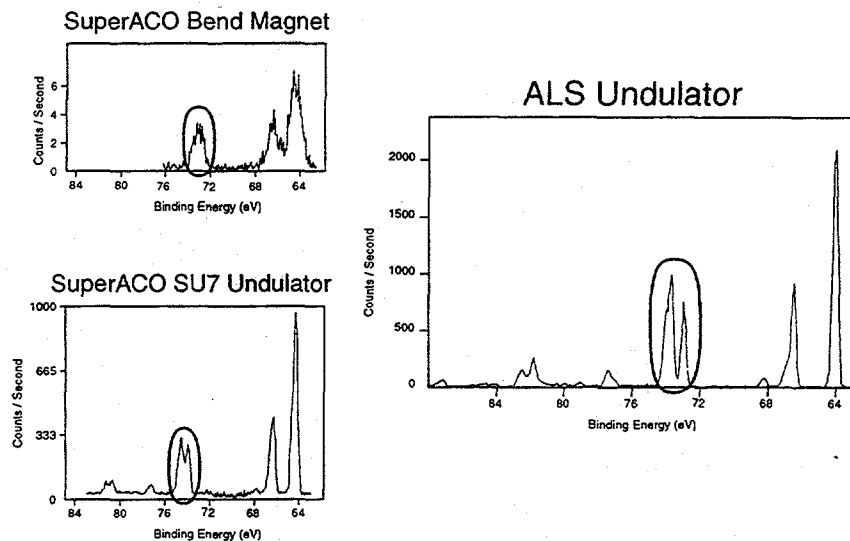

Figure 24. Photoelectron spectra for emission from a hollow lithium state. Data from SuperACO bend magnet and undulator, and from ALS undulator showing the improved resolution on ALS Beamline 9.0.1. Photon and electron energy widths are reduced for the ALS measurement due to the high flux and spectral resolution on Beamline 9.0.1. [SuperACO bend magnet spectrum from F.J. Wuilleumier, private communication; SuperACO SU7 undulator spectrum from Journal et al., Phys. Rev. Lett. **76**, 30 (1996); ALS undulator spectrum from Diehl, et al., Phys. Rev. Lett. **76**, 3915 (1996)].

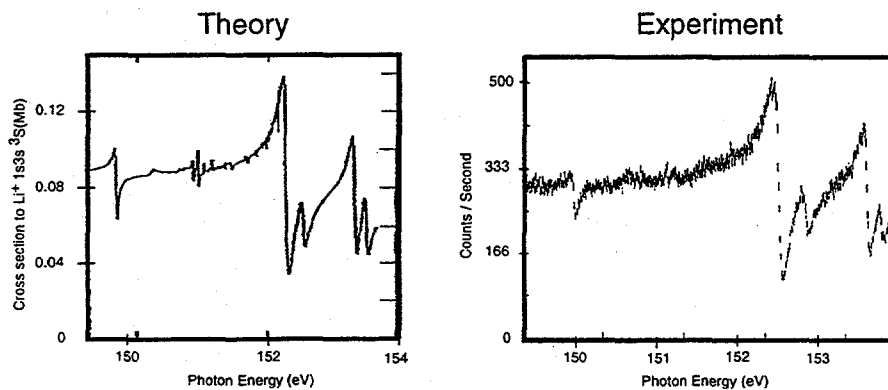

Figure 25. Hollow lithium: photoelectron emission to  $\text{Li}^* 1s2s \ ^3S$  state, showing excellent agreement of theory and experiment. (Diehl et al., 1996)

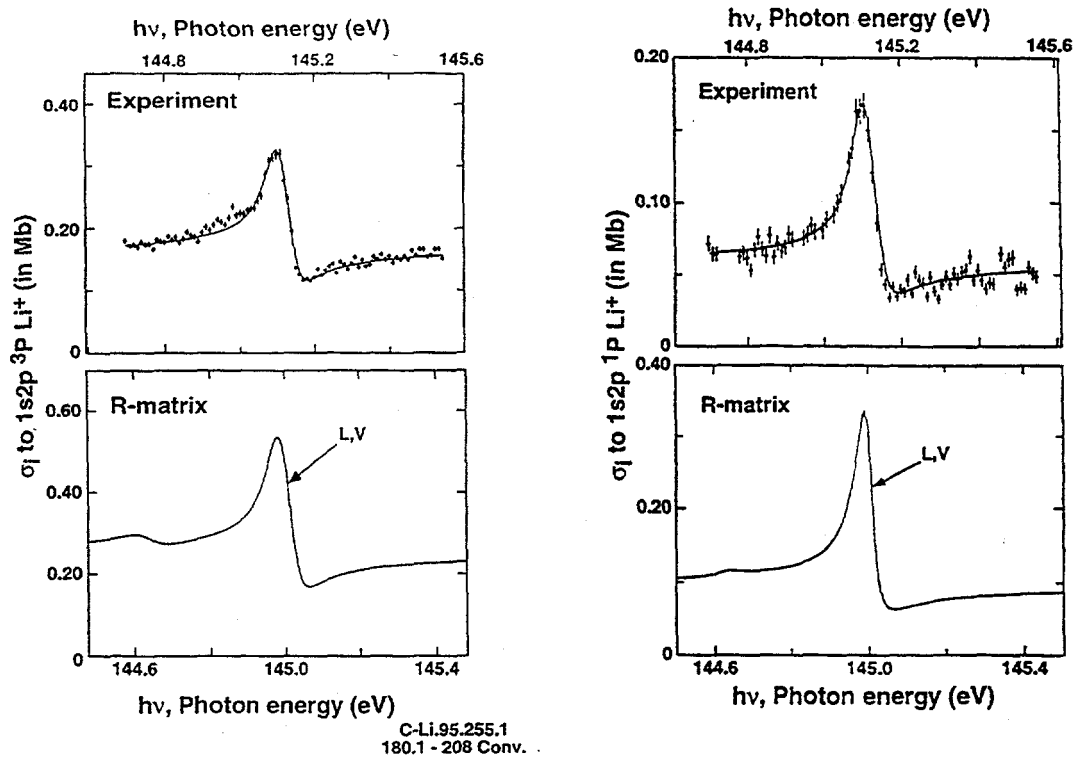

Figure 26. Hollow lithium: even-parity states from laser-excited lithium atoms. Photoemission and R-matrix calculations for photoionization of the Li  $1s^2 2p \ ^2P_{3/2}$  state into the  $1s2p \ ^3P$  and  $1s2p \ ^1P$  states of the  $Li^+$  ion. (D. Cubaynes, S. Diehl, L. Journel, B. Rouvellou, J.-M. Bizau, S. Al Moussalami, F. J. Wuilleumier, N. Berrah, L. Voky, P. Faucher, A. Hibbert, C. Blancard, E. Kennedy, T. J. Morgan, J. Bozek, and A. S. Schlachter, submitted to Phys. Rev. Lett.)