

## COMPUTED MICROTOMOGRAPHY OF RESERVOIR CORE SAMPLES

### DISCLAIMER

This report was prepared as an account of work sponsored by an agency of the United States Government. Neither the United States Government nor any agency thereof, nor any of their employees, makes any warranty, express or implied, or assumes any legal liability or responsibility for the accuracy, completeness, or usefulness of any information, apparatus, product, or process disclosed, or represents that its use would not infringe privately owned rights. Reference herein to any specific commercial product, process, or service by trade name, trademark, manufacturer, or otherwise does not necessarily constitute or imply its endorsement, recommendation, or favoring by the United States Government or any agency thereof. The views and opinions of authors expressed herein do not necessarily state or reflect those of the United States Government or any agency thereof.

M. E. Coles

Mobile Exploration and Producing Technical Center  
P. O. Box 819047, Dallas, Texas 75381-9047

P. Spanne

Brookhaven National Laboratory, Upton, New York 11973-5000

E. L. Muegge

Mobile Exploration and Producing Technical Center  
P. O. Box 819047, Dallas, Texas 75381-9047

K. W. Jones

Brookhaven National Laboratory, Upton, New York 11973-5000

Presented at

1994 International Symposium of the Society of Core Analysts

Stavanger, Norway

September 12-14, 1994

# MASTER

DISTRIBUTION OF THIS DOCUMENT IS UNLIMITED *NW*

By acceptance of this article, the publisher and/or recipient acknowledges the US Government's right to retain a nonexclusive, royalty-free license in and to any copyright covering this paper.

## **DISCLAIMER**

**Portions of this document may be illegible in electronic image products. Images are produced from the best available original document.**

# COMPUTED MICROTOMOGRAPHY OF RESERVOIR CORE SAMPLES

by

M. E. Coles<sup>1</sup>, P. Spanne<sup>2</sup>, E. L. Muegge<sup>1</sup> and K. W. Jones<sup>2</sup>

## Abstract

X-ray computed tomography (CT) is often utilized to evaluate and characterize structural characteristics within reservoir core material systems. Generally, medical CT scanners have been employed because of their availability and ease of use. Of interest lately has been the acquisition of three-dimensional, high resolution descriptions of rock and pore structures for characterization of the porous media and for modeling of single and multiphase transport processes. The spatial resolution of current medical CT scanners is too coarse for pore level imaging of most core samples. Recently developed high resolution computed microtomography (CMT) using synchrotron X-ray sources is analogous to conventional medical CT scanning and provides the ability to obtain three-dimensional images of specimens with a spatial resolution on the order of micrometers. Application of this technique to the study of core samples provides two- and three-dimensional high resolution description of pore structure and mineral distributions. Pore space and interconnectivity is accurately characterized and visualized. Computed microtomography data can serve as input into pore-level simulation techniques. A generalized explanation of the technique is provided, with comparison to conventional CT scanning techniques and results. Computed microtomographic results of several sandstone samples are presented and discussed. Bulk porosity values and mineralogical identification were obtained from the microtomograms and compared with gas porosity and scanning electron microscope results on tandem samples.

## Introduction

Computed X-ray tomography is often utilized to evaluate and characterize structural characteristics within reservoir core material systems. Generally, medical computed tomography (CT) scanners have been employed because of their availability and relative ease of use. Applications include core screening and characterization of inhomogenities and damage in reservoir core samples,<sup>1-4</sup> as well as characterization of fluid distributions within core material systems.<sup>5-10</sup> Additionally, efforts to quantify and improve the accuracy of CT scanning techniques have been successful.<sup>2,3,11,12</sup>

Of interest lately has been the acquisition of three-dimensional, high resolution description of rock structure and pore level characterization for the modeling of multiphase transport processes. Medical CT scanners are generally limited to no better than .25 by .25 by 1.5 mm<sup>3</sup> in volume resolution and therefore cannot provide information sufficient to define the three-dimensional pore structure of reservoir rock. Although two-dimensional pore structure is easily imaged with scanning electron microscopes (SEM), there is some question as to the destructive nature of the sampling method and extension of the two-dimensional data to three dimensions. Nuclear magnetic resonance (NMR) imaging provides three-dimensional information with a resolution exceeding that of medical CT scanners. Resolution in state-of-

1. Mobil Exploration and Producing Technical Center, P. O. Box 819047, Dallas, Texas, 75381-9047
2. Brookhaven National Laboratory, Upton, New York, 11973. Work supported in part by the U.S. Dept. of Energy under Contract DE-AC02-76CH00016.

the-art NMR microimaging is on the order of fifteen micrometers. NMR imaging however, provides information only about the fluids contained within the rock: information about the rock itself is inferred, not directly measured.

Recently developed computed microtomography (CMT) offers unique imaging capabilities, compared with conventional optical and electron microscopes or NMR imaging. CMT is analogous to medical X-ray absorption CT scanning and produces images with a much higher spatial resolution. Synchrotron X rays, generated in a storage ring for relativistic electrons, are often employed for microtomography. With synchrotron X-ray CMT, three-dimensional maps of linear X-ray attenuation coefficients inside small samples can be obtained with about 1% accuracy and resolution approaching 1  $\mu\text{m}$ . Synchrotron X rays have been used to generate microtomograms of biological samples, thermal spray coatings, coal and heterogeneous catalysts.<sup>13-18</sup>

Recently, there has been interest in using synchrotron X-ray CMT for characterization of porous media for geological applications.<sup>19</sup> Advantages include very high spatial resolution (reported 5 micrometers), narrow energy band (less artifacts) and tunability (increased sensitivity and mineralogical information). Microtomographic images of real rock can serve as boundary conditions for rigorous fluid flow modeling on massively parallel computers.<sup>20-22</sup> With microtomographic data, opportunities therefore exist to significantly impact the description and understanding of fluid transport properties within core material systems.

In order to test the feasibility and develop the method for obtaining and using microtomographic data in fluid flow modeling, microtomographic data sets were obtained for several different reservoir core and mineral samples using synchrotron X rays produced at the National Synchrotron Light Source (NSLS) at Brookhaven National Laboratories (BNL). This paper presents the technique underlying the tomographic imaging process and CMT results for several sandstone core samples. Comparison of results with those obtained with medical CT scanning, gas porosity and SEM measurements are provided.

## **Computed Microtomography Theory and Measurement Process**

CMT is analogous to medical CT scanning, but can be performed with a spatial resolution down to the micrometer range. As with medical X-ray CT scanning, CMT data collection for a tomographic slice through a sample is performed by measuring the relative number of transmitted X rays for a large number of X-ray paths with different radial and azimuthal coordinates. The sampling can be performed either by using a single pencil beam and detector (called first generation scanning), or by using a wide X-ray beam and an array of detectors with high spatial resolution capability. With first generation scanning (which we have utilized in this work) it is possible to obtain spatial resolutions, on the order of one micrometer. Use of detector arrays, on the other hand, allows considerably faster CMT, but at some loss of spatial resolution.

After CT data collection, the line integrals of the linear attenuation coefficients are obtained by taking the logarithm of the reciprocal of the relative number of transmitted photons. This is input to a reconstruction algorithm<sup>23</sup> which produces a reconstructed image consisting of a matrix of linear attenuation coefficients in a thin slice through the sample. A linear attenuation coefficient reflects the probability per unit length for an X ray to interact as it passes through a material, and is a function of the atomic number and the bulk density of that material and the X-ray energy.

Recently, X rays produced at synchrotron X-ray sources have been used for CMT, resulting in high spatial resolution tomograms for biological, catalyst, spread coatings and geological samples.<sup>13-19</sup> In synchrotron radiation sources, radiation (X-ray and UV) is produced when relativistic electrons are accelerated radially by a magnetic field. The resulting intense, almost parallel beam of X-rays is ideal for high resolution CMT. Spatial resolution on the order of a micron has been achieved.<sup>13-15</sup> The ability to tune the energy and bandpass of synchrotron X rays using crystal based X-ray monochromators serves to minimize beamhardening effects and allows spatially resolved elemental mapping.<sup>15</sup>

## Experimental

Several core samples were selected for CMT after scanning with a medical CT scanner (Elscent 2002). Helium porosimetry and steady state gas flow permeability measurements were obtained on the samples (see Table 1). The samples were then epoxy impregnated and two and three mm 'microcores' were drilled from the epoxy impregnated specimens. Microtomographic images of the 'microcores' were obtained using synchrotron X rays produced at the National Synchrotron Light Source (NSLS) at Brookhaven National Laboratory (BNL). At the NSLS, intense well collimated beams of X-ray and ultraviolet radiation are produced in separate accelerator rings. Thirty X-ray and sixteen UV ports or beamlines (designated X1-30 and U1-16) are available and are utilized to obtain a wide range of experimental data.

The 'microcore' samples were scanned at the X26C beamline of the NSLS. This beam line can provide both focused and unfocused synchrotron radiation from a bending magnet, the unfocused usable in the energy range of 5 to 30 keV. The CMT apparatus,<sup>13,15</sup> operated within the shielded hutch at the X26C experimental station, is shown schematically in Figure 1. The actual experimental setup is shown in Figure 2. An assembly of stepping motor driven translators and rotators were used to move the object through the radiation beam during sampling of the X-ray attenuation. A vertical translator was used to select the slice to be imaged. The core sample to be scanned was mounted on a horizontal rotator on a goniometric cradle. The cradle was used to align the rotation plane parallel to the radiation beam. A horizontal translator was used to scan the object through the beam while the attenuation was sampled. The stepping motors were controlled by a computer with programs automatically placing the moving stages at the correct start position relative to the radiation beam after specifying the scan width and sampling distance.<sup>13</sup> The size of the radiation beam was defined by two pairs of perpendicularly-oriented 1 mm thick tantalum slits. Imaging time ranged from 8 to 90 minutes per slice, depending on the size of the imaged object, the required spatial resolution and the attenuation contrast in the object.

After reconstruction using a filtered back projection algorithm,<sup>23</sup> microtomographic images were transferred to a Sun 6/70 workstation for visualization and processing. Microtomography scans were also performed on small pieces of minerals in order to determine characteristic attenuation values. SEM results were obtained on tandem samples for two of the sandstones.

## Results

### Qualitative Image Analysis

CT scans and microtomographic images of three sandstones are shown in Figure 3. Color has been added to enhance visibility of features slightly. Histograms, showing the frequency of attenuation values contained within the respective images are also presented. The CT spatial resolution was .25 by .25 by 3 mm<sup>3</sup> and the spatial resolution for the CMT was 5 by 5 by 5 μm<sup>3</sup>. The microtomograms clearly show pores, structural features and mineralogical distributions not visible with the resolution of the CT scanner. The higher resolution of the CMT images are reflected in their histograms which show clearer separation of features than the CT histograms.

CT scans of a core sample at the lower spatial resolution may or may not reflect the pore level heterogeneity of the core. This is illustrated by comparing the CT scan (core level) and CMT (pore level) results of the three core samples shown in Figure 3. Uniformity at both the core and pore scale are indicated by both the CT scan and CMT images of sandstone #1. Sandstone #2 illustrates a case where the core level (CT scan) image shows heterogeneity and the pore level (CMT) image is relatively uniform. Sandstone #3 shows heterogeneity at both the core and pore level.

### Identification of minerals

The presence of minerals is evident in the computed microtomograms of Figure 3. The minerals can be identified by comparing their attenuation coefficients represented in the image to those obtained from microtomograms of known mineral samples. For example, the values represented in the dark orange, lighter orange and white areas of the CMT image of sandstone #2 were found to be 810, 1320, and 2690 m<sup>-1</sup> respectively. By comparison with experimental values for known minerals quartz and feldspar are easily identified as the darker and lighter orange regions. The small, bright areas are probably siderite or pyrite. This is confirmed by SEM data on a tandem sample. It is not clear at this time if kaolinite can be identified in the microtomograms.

### Calculation of Porosity

In conventional CT measurements, bulk porosity values of a sample can be obtained by comparing the attenuation values obtained with and without saturation with a suitable attenuating fluid. Knowledge of the attenuation characteristics of that fluid is required. The

high resolution offered by CMT allows porosity calculations directly from the histogram of a single microtomographic image. For example, in the CMT histograms shown in Figure 3, the taller peaks appearing at higher attenuation values are due to attenuation of the rock material. The smaller, lower attenuation value peaks are attributed to the epoxy filled pore space. Porosity is easily calculated as the area under the epoxy peak (pore space) divided by the total area represented by the core sample. Porosity calculated from a cumulative histogram of 13 consecutive slices of sandstone #1 gave a value of 24.5%. Porosity calculated from a histogram of four consecutive slices of sandstone #2 was 22.1%. Helium porosimetry measurements of these sandstones samples prior to epoxy impregnation and microcore drilling showed 27.3 and 21.6% porosity respectively. SEM results for tandem samples showed porosity to be 25.1 and 22.3% .

The porosity calculated from the cumulative histogram of eight slices of sandstone #3 gave a value of 12.7%, which does not agree with helium porosimetry measurements of 21.3%. This discrepancy is most likely a result of the presence of pore space which is below the 5 by 5 by 5  $\mu\text{m}^3$  resolution of the microtomogram. This is indicated by the extreme trailing edge of attenuation values which are slightly lower than the core material peak (see Histogram) and is represented by the presence of light blue on the CMT image of sandstone # 3 in Figure 3. An SEM of this sandstone sample will be preformed to verify this hypothesis. Results are summarized in Table 1.

### Three-Dimensional Characterization

Three-dimensional characterization of core samples can be obtained by stacking together multiple CMT slices. A volume data set, created from 95 consecutive CMT slices of a 2 mm diameter sandstone sample is shown in Figure 4. The data provides three-dimensional characterization of the reservoir core material and can be used as input to transport property simulation. Pore space interconnectivity can be conveniently represented and characterized with such volumetric tomographic data. For visualization of the pore space, using computer image processing, the rock matrix material can be set transparent and the pore space represented as interconnecting pathways. This is illustrated in Figure 5. Here, different colors correspond to connected pathways of the pore network. In this picture, green represents pores which are relatively unconnected and red indicates pore space which is connected across the length of the core sample. Transport property estimation for multiphase flow in porous media (for example, relative permeability) has been demonstrated in synthetic media and extension to real rock systems using CMT data is currently underway.<sup>20-22</sup> Wettability distribution maps can be created with the same resolution as the tomogram and the effect of different wettability distributions on relative permeability can be probed.<sup>21</sup>

## Conclusions And Summary

Computed microtomography provides excellent high resolution two- and three-dimensional pore level images of core samples. The data provides unique information compared to that obtained with conventional CAT scanning, SEM or NMR techniques. Bulk porosity values obtained from the microtomograms presented here generally correlate well with gas porosity and SEM measurements. Discrepancies may occur if the microtomogram is not obtained with sufficient spatial resolution. Mineralogical identification and distributions can be obtained

from the microtomograms by comparison with mineral attenuation values or tandem SEM measurements.

Computed microtomography provides full characterization of the core geometry, porosity and mineralogical distributions. Pore interconnectivity can be visualized and characterized. This characterization provides valuable data for the understanding and modeling of fluid transport and mechanical processes occurring in real porous media systems. For example, the impact of different wettability distributions on relative permeability within reservoir material can be probed. Given microtomographic characterization of any core material, at sufficient spatial and contrast resolution, and occupying fluid properties, any transport property can be modeled and simulated.

### Acknowledgment

We would like to thank Mobil Exploration and Producing Technical Center for permission to publish this material. We acknowledge the assistance of A. W. Chester and M. D. Farnos of Mobil Research and Development during the first CMT run. Mark Rivers, Consortium for Advanced Radiation Sources, University of Chicago, assisted in reformatting of data and R. P. Kehl of Kehlco assisted in image presentation. Thanks go to J. R. Dixon of MEPTEC for SEM results and discussions and to R. D. Hazlett of MEPTEC for discussions and information concerning the importance and utility of this data.

### References

1. Vinegar, H.J., "X-Ray CT and NMR Imaging of Rocks", J. Pet. Tech., March 1986, pp 257-59.
2. Wellington, S.L. and Vinegar, H.J., "X-Ray Computerized Tomography," J. Pet. Tech., August 1987, pp 885- 98.
3. Hunt, P.K., Engler, P., and Bajsarowicz, C., "Computed Tomography as a Core Analysis Tool: Applications and Artifact Reduction Techniques," Soc. Pet. Eng. 16952, 1987.
4. Gilliland, R.E. and Coles, M.E., "Use of CT Scanning in the Investigation of Damage to Unconsolidated Core," Soc. Pet. Eng. 19408.
5. Yang, Y., Ayril, S., and Gryte, C.C., "Computer-Assisted Tomography for the Observation of Oil Displacement in Porous Media," Soc. Pet. Eng. J., February 1984, pp 53-55.
6. Vinegar, H.J., and Wellington, S.L., "Tomographic Imaging of Three Phase Flow Experiments," Rev Sci Inst. 58(1), January 1987, pp 96-107.
7. Withjack, E.M., "Computed Tomography for Rock-Property Determination and Fluid-Flow Visualization," Soc. Pet. Eng. 16951, 1987.
8. Hove, A.O., Nilsen, V., and Leknes, J., "Visualization of Xanthan Flood Behavior in Core Samples by Means of X-Ray Tomography," SPE/DOE 17342, 1988.
9. Sprunt, E.S., Desai, K.P., Coles, M.E., Davis, R.M., and Muegge, E.L., "Cat Scan Monitored Electrical Resistivity Measurements Show Problems Achieving Homogeneous Saturation", Soc Pet. Eng. 21433, Middle East Oil Show, Bahrain, 1991.
10. Marek, B.F., Hartman, K.J., and McDonald, A.E., "Three Phase Relative Permeability of Limestones Having Bimodal Pore Size Distributions", Soc. Pet. Eng. 21374, Middle East Oil Show, Bahrain, 1991.



11. Coles, M.E., Muegge, E.L., and Sprunt, E.S., "Applications of CAT Scanning for Oil and Gas Production Research," IEEE Trans. Nuc. Sci., Vol 38, No. 2, April 1991, pp. 510-515.
12. Coles, M.E., Muegge, E.L., and Marek, B.F., "Use of Attenuation Standards for CAT Scanning Applications Within Oil and Gas Production Research", Soc. Core Analysts Paper 9223.
13. Spanne, P. and Rivers, M., "Computerized Microtomography using Synchrotron Radiation from the NSLS", Nucl. Instr. Meth. Phys. Res., 1987, pp 1063-67.
14. Nichols, M.C., Kinney, J. H., Johnson, Q.C., Saroyan, R.A., Bonse, U., Nusshardt, R., and Pahl, R., "Synchrotron Microtomography of Supported Catalysts", Rev. Sci. Inst., 60(7), July, 1989.
15. Jones, K.W., Spanne, P., Webb, S.W., Conner, W.C., Beyerlein, R.A., Reagan, W. J., and Dautzenberg, F.M., "Catalyst Analysis using Synchrotron X-ray Microscopy," Nuc. Inst. Meth. Phys. Res., 1991, pp 427-432.
16. Conner, W.C., Webb, S.W., Spanne, P., and Jones, K.W., "Use of X-ray Microscopy and Synchrotron Microtomography to Characterize Polyethylene Polymerization Particles," Macromolecules, 1990, 20, pp 4742-47.
17. Flannery, B.P., Deckman, H.W., Roberge, W.G., and D'Amico, K.L., "Three Dimensional X-ray Microtomography", Science, Vol 237, 18 September 1987.
18. Spanne, P., Jones, K. W., Herman, H. and Riggs, W. L., "Measurements of Imperfections in Thermal Spray Coating Using Synchrotron Computed Microtomography," J. Thermal Spray Tech. 1993,2,N2,121-25.
19. Dunsmuir, J. H., Ferguson, S.R., D'Amico, K.L., and Stokes, J.P., "X-Ray Microtomography: A new Tool for the Characterization of Porous Media", Soc. Pet. Eng. 22860.
20. Buckles, J.J., and Eggert, K.G., "Pore Scale Simulation of Improved Oil Recovery Processes", presented at the Computational Technology Initiative for the Oil and Gas Industry, Sante Fe, New Mexico, June 20-23, 1993.
21. Hazlett, R.D., Vaidya, R.N., Coles, M.E., Buckles, J.J., Grunau, D.W., Chen, S.Y., and Eggert, K.G., "Simulation of Wettability Effects on Displacement Processes by Cellular Automata Methods", to be presented at the International Symposium on the Effects of Wettability on Oil Recovery, Sept. 1994.
22. Buckles, J.J., Hazlett, R.D., "Application of Lattice Boltzmann Simulation to Oil Reservoir Engineering", presented at the First International Connection Machine Users Meeting, Sante Fe, February 16-18, 1994.
23. Herman, G.T., Image Reconstruction From Projections, Academic Press, 1980.

**TABLE 1**  
**SUMMARY OF SANDSTONE VALUES**

Sample	Porosity (%)	Permeability (md)	Porosity Calc. from CMT(%)	Porosity Calc. from SEM
Sandstone #1	27.3	2520	24.5	25.1
Sandstone #2	21.6	2720	22.1	22.3
Sandstone #3	21.3	469	12.7	

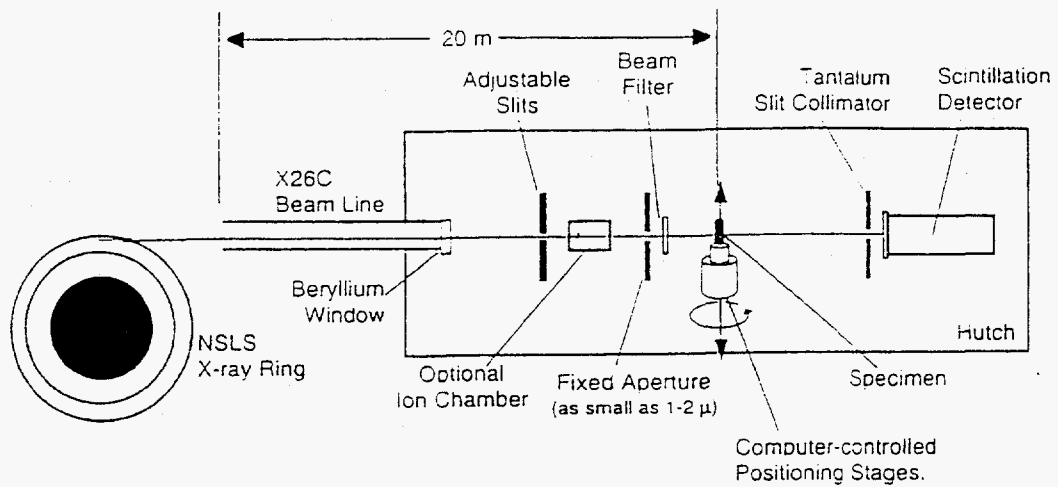

Figure 1: Schematic illustrating microtomographic apparatus for scanning of core sample. First generation scanning is accomplished by rotating and translating the sample through the x-ray beam.

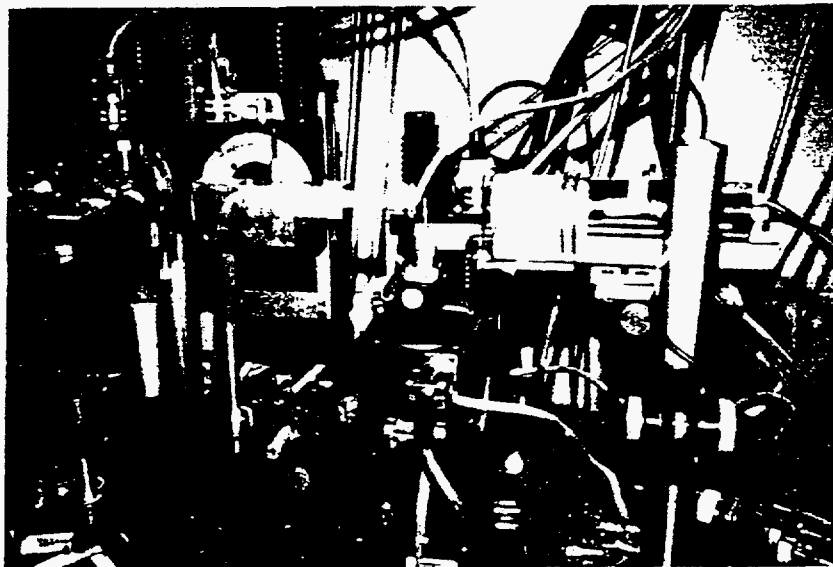
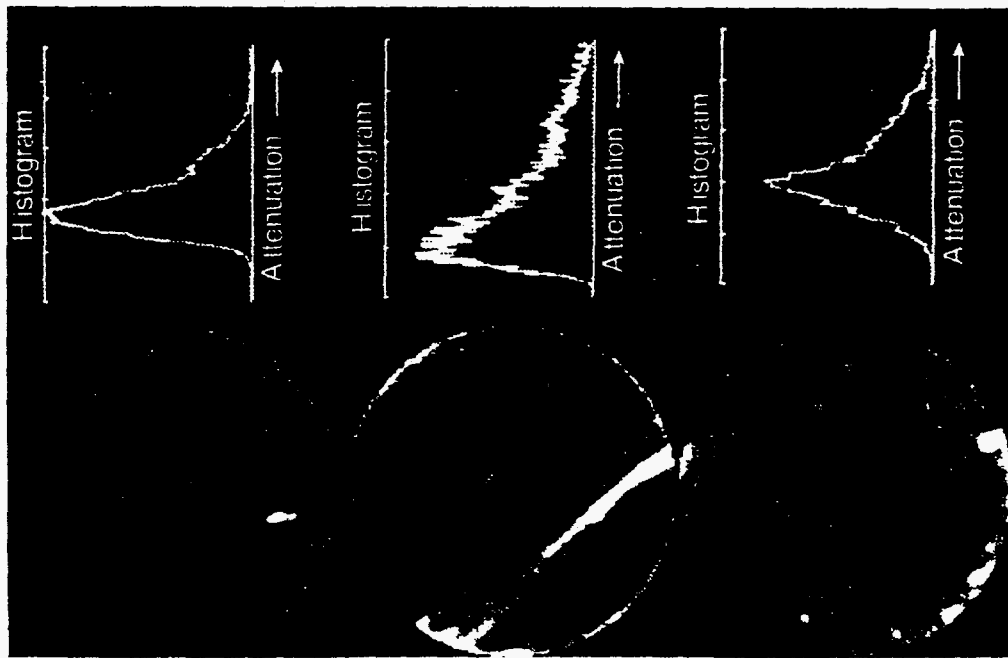

Figure 2: Microtomographic apparatus for scanning of core samples. 2 mm core sample can be seen mounted on translational assembly in the center of the picture. X-rays enter from the left. X-ray detector can be seen on the right.

### CT Scanning (CT)



Sandstone #1

Sandstone #2

Sandstone #3

### Computed Microtomography (CMT)

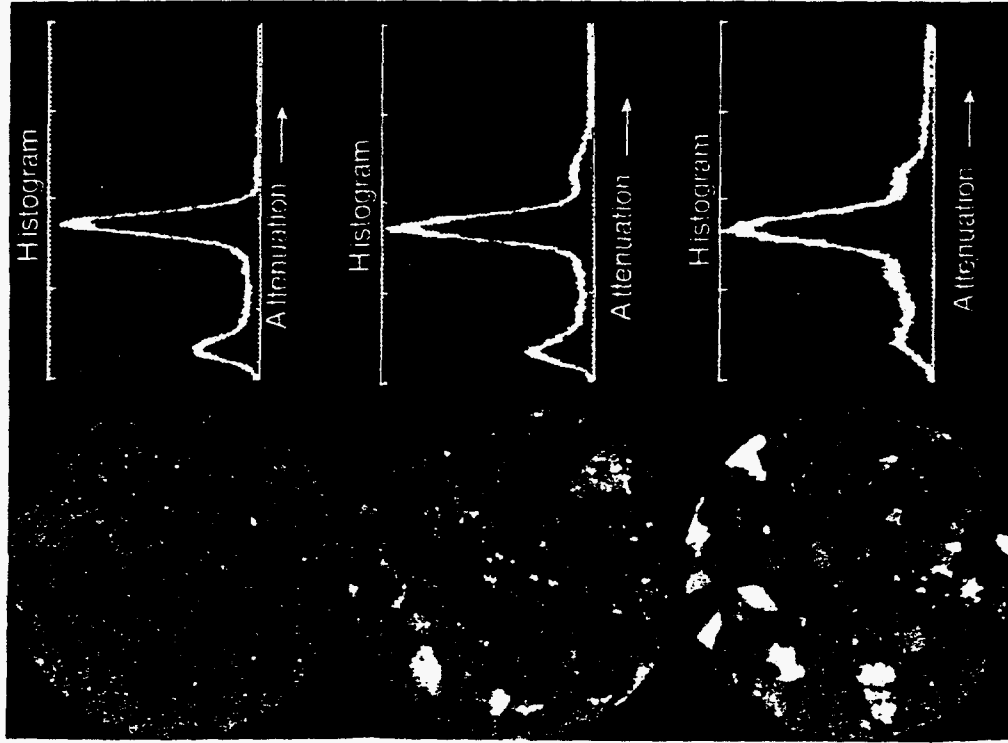

Figure 3: CT scans and microtomograms of sandstone samples. CT samples were 2.54 cm and CMT samples were 2 mm in diameter. Note greatly increased resolution and measurement sensitivity in CMT.



Figure 4: Volume data set for 2 mm sandstone sample created from 95 consecutive slices with a resolution 10 by 10 by 10 microns. Pore space is represented as black, the quartz rock material is burnt orange and siderite is white. Transparency is used to allow visualization through the volume image.

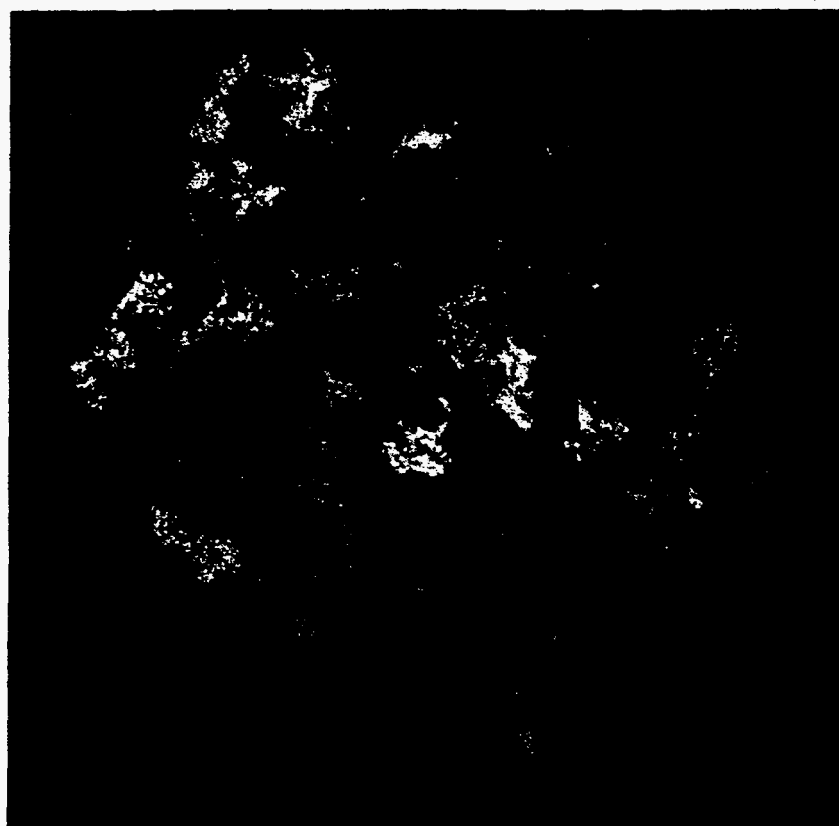

Figure 5: Interconnectivity of pore space. Rock matrix has been made transparent. Colors indicate size (number of voxels) of independent clusters or porosity elements.