

AUGUST 1995

# QUALITY ELECTRIC MOTOR REPAIR:

## A GUIDEBOOK FOR ELECTRIC UTILITIES

RECEIVED  
APR 30 1996  
OSTI

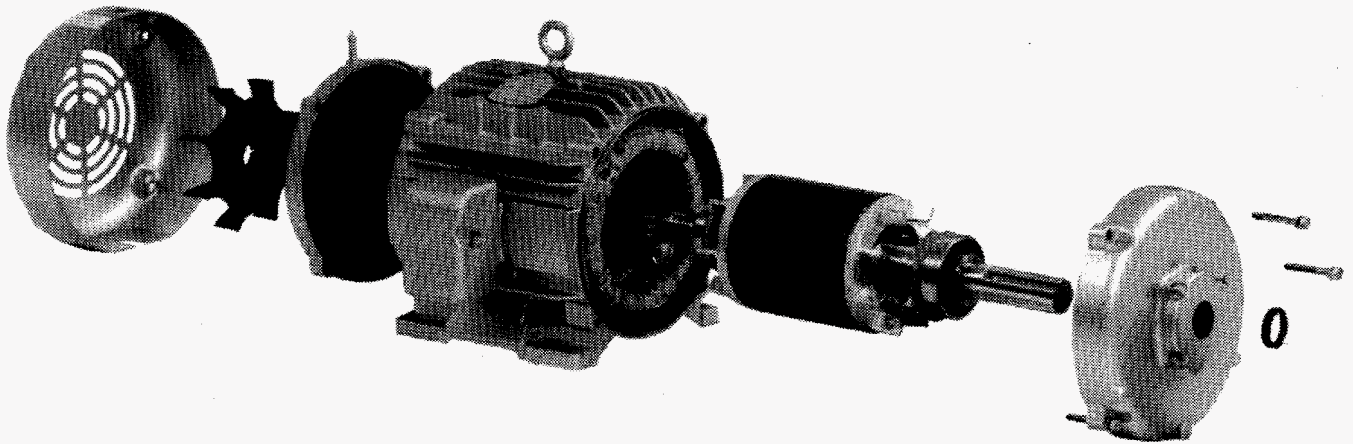

DISTRIBUTION OF THIS DOCUMENT IS UNLIMITED

# MASTER



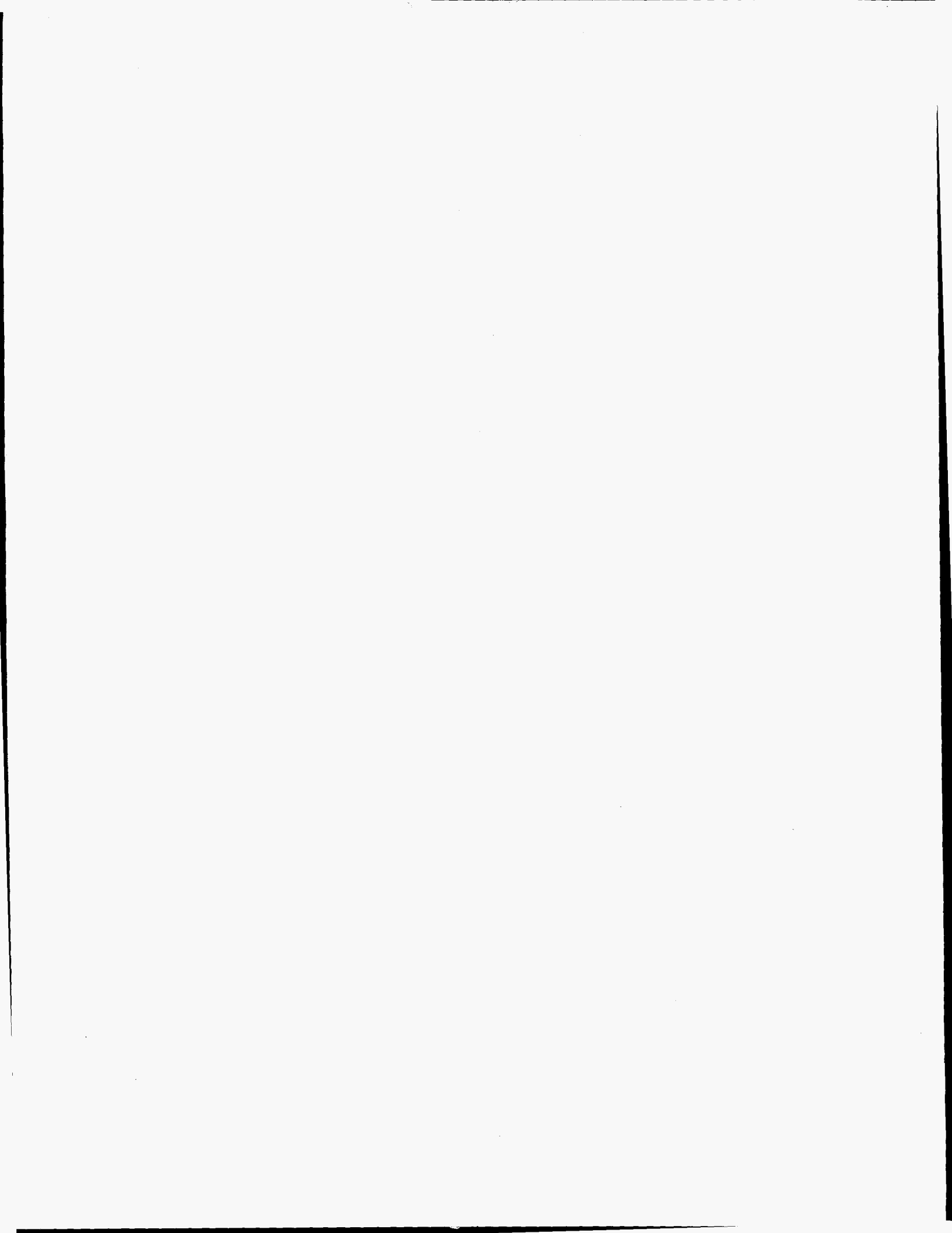

# BPA Report Summary

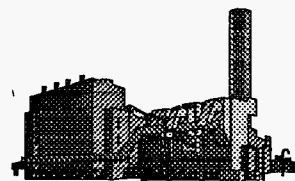

## Industrial Technology

---

**TITLE** QUALITY ELECTRIC MOTOR REPAIR:  
A GUIDEBOOK FOR ELECTRIC UTILITIES

---

**SUMMARY** The guidebook provides utilities with a resource for better understanding and developing their roles in relation to electric motor repair shops and the industrial and commercial utility customers that use them. The guidebook includes information and tools that utilities can use to raise the quality of electric motor repair practices in their service territories.

---

**BPA PERSPECTIVE** This R&D project is one of a number of activities which support BPA's Market Transformation efforts. Market Transformation is a strategic effort initiated by BPA to induce lasting structural or behavioral changes in the market that result in the adoption and penetration of energy efficient technologies and practices

---

**BACKGROUND** More motor horsepower is repaired than sold each year. Improperly repairing and rewinding motors can decrease the efficiency of individual motors by up to 5 percent. Estimates of the average reduction in efficiency after repair associated with current practice range from 0.5 to 2.5 percentage points. However, efficiency decreases are not unavoidable or unexplainable consequences of repair or rewinding. Case studies of rewound motors have shown decreased efficiency to be linked to specific shortcuts, errors, or parts substitutions.

A 1 percent decrease may appear inconsequential, but when the number of repairs and motor operating hours are taken into account, the potential energy and dollar savings are significant. If all repaired motors currently in operation had been repaired with no decrease in efficiency, savings would be about 2,000 aMW, roughly equivalent to the output of two large thermal power plants. Maintaining energy efficiency during repair usually improves motor performance and reliability after repair, significantly contributing to

the productivity and competitiveness of motor repair customers. By working with the motor repair industry utilities can provide information and services critical to helping industrial and commercial customers manage their energy use and improve productivity. Providing these types of services and education will be come more essential as the utility industry faces increasing competition for customers.

---

**OBJECTIVE**

To provide a guidebook to help educate Electric utilities on motor repair practices and opportunities for improvement. This objective is part of a broader goal to achieve a more energy efficient population of motors through appropriate selection of high efficiency new motors and improvements in repairs.

---

**PROJECT  
MANAGER**

Craig Wohlgemuth, P.E.  
Technical Assessment/R&D-MPMT  
Bonneville Power Administration  
P.O. Box 3621  
Portland, OR 97208  
(503) 230-3044

---

**ORDERING  
INFORMATION**

Report Number: DOE/BP-2747

**For copies of Publications on this list please contact:**  
**Public Information Office**  
**Bonneville Power Administration**  
**P.O. Box 3621**  
**Portland, OR 97208**  
**(503) 230-3478 (Portland)**  
**or**  
**1-800-622-4520 (Document Request Line)**

# **Quality Electric Motor Repair: A Guidebook for Electric Utilities**

Prepared by: Vince Schueler and  
Johnny Douglass

Washington State Energy Office  
925 Plum Street S.E.  
P.O. Box 43165  
Olympia, WA 98504-3165



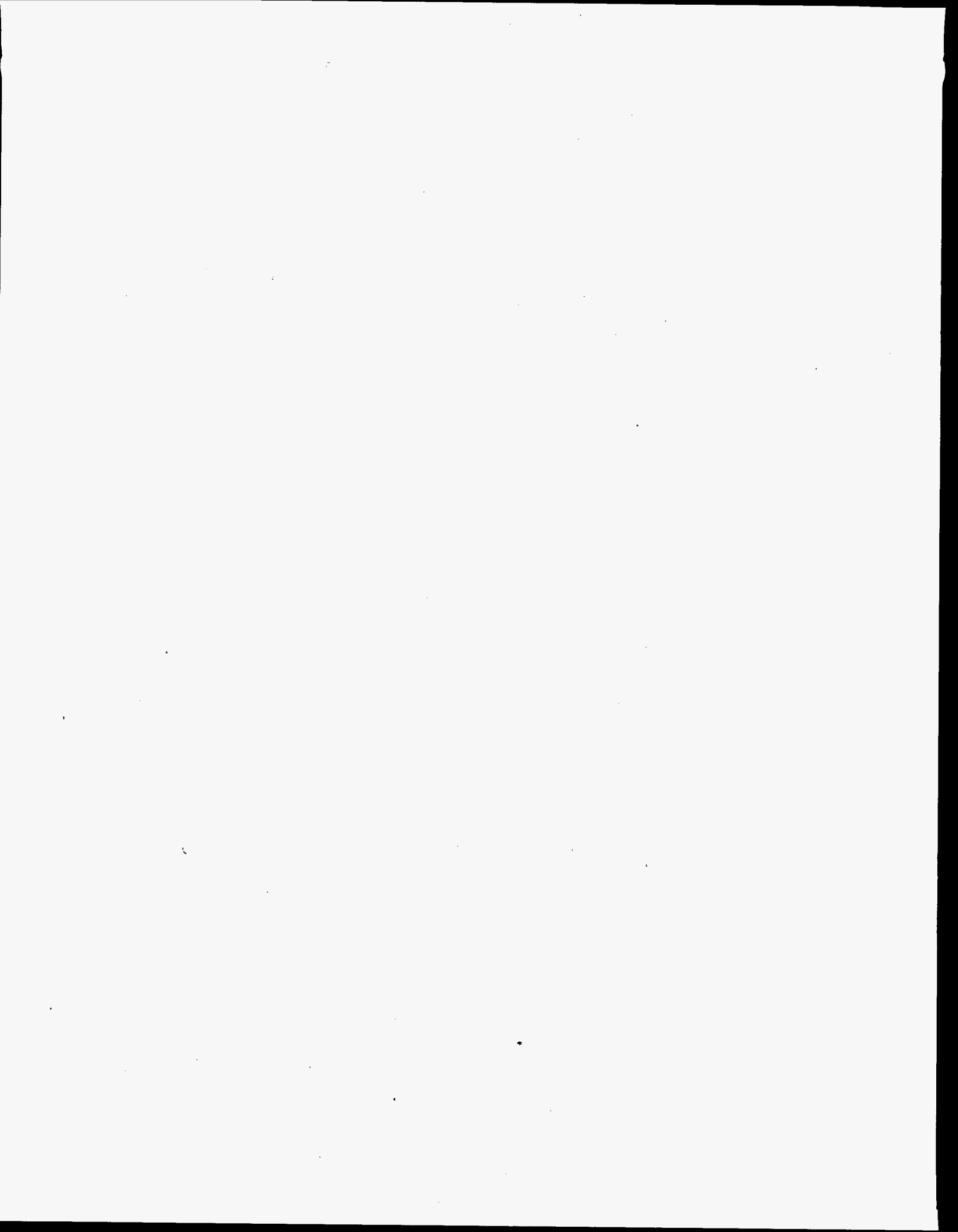

---

## Disclaimer

This report was prepared by the Washington State Energy Office as an account of work sponsored by the Electric Power Research Institute and the Bonneville Power Administration. Neither the United States, the Bonneville Power Administration, the Electric Power Research Institute, the State of Washington, the Washington State Energy Office, nor any of the contractors, subcontractors or their employees, makes any warranty, expressed or implied, or assumes any legal responsibility for the accuracy, completeness, or usefulness of any information, apparatus, product, or process disclosed within the report.

---

## Acknowledgments

The authors wish to thank the Electric Power Research Institute (EPRI) and the Bonneville Power Administration (BPA) for funding this project. Particular thanks are due to Ben Banerjee at EPRI and Craig Wohlgemuth at BPA for their support and direction. Invaluable advice and review comments were provided by Wallace Brithinee of Brithinee Electric, Steve Darby of Darby Electric, Richard Nailen of Wisconsin Electric Power Company and Ray Saddler of Canyon Motor Rewind.

This project was a team effort at the Washington State Energy Office (WSEO). We would not have been able to deliver this project without help of word processing support from Kim Acuff, clerical and data entry from Marilyn Van Arkel, and support from WSEO's information systems team. Graphics and layout were designed by Angela Boutwell and Kristi Kaech in WSEO's graphic team. The editing of Mary Nell Harris at Wasser Communications added considerably to the clarity of the final product.

---

## Preface

Much of this guidebook is based on the research conducted on behalf of EPRI and BPA in 1993 and 1994. This research was summarized in *Electric Motor Repair Industry Assessment: Current Practice and Opportunities for Improving Customer Productivity and Energy Efficiency—Phase 1 Report*. This report contains a much more detailed accounting of current motor repair and testing practices and issues which influence quality repair. You may contact the Motor Challenge Information Clearinghouse to obtain current information on availability of this publication.

For information on any of these reference materials, contact the Motor Challenge Information Clearinghouse, P.O. Box 43171, Olympia, WA 98504-3171; Hotline (800) 862-2086; U.S. Department of Energy. Access and availability may vary depending upon user affiliations and current distribution policies of the author/organization.

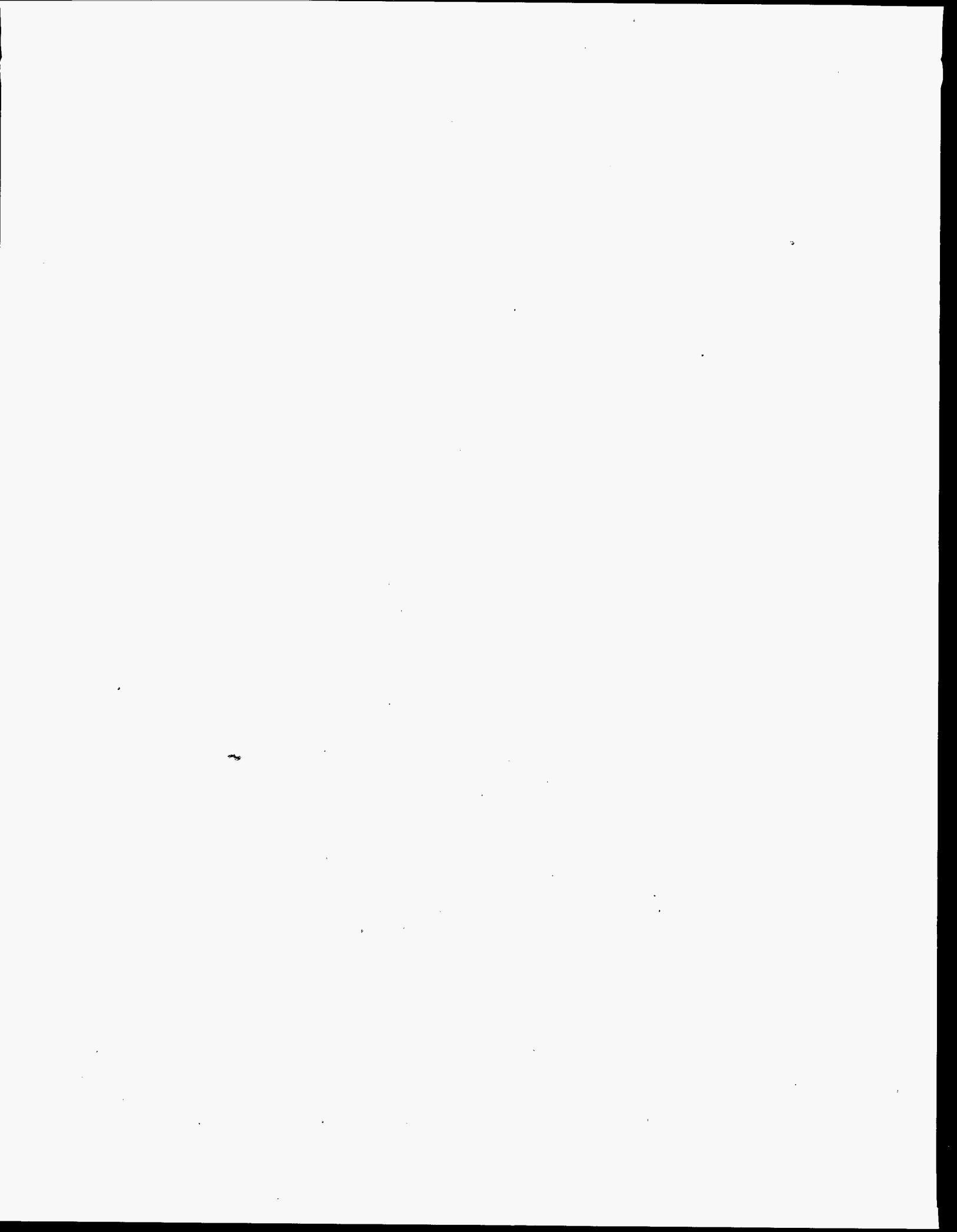



---

## Acronyms

ABMA	American Bearing Manufacturers Association
aMW	average megawatts
CEE	Consortium for Energy Efficiency
DSM	demand-side management
EASA	Electrical Apparatus Service Association
EPRI	Electric Power Research Institute
IEEE	Institute of Electrical and Electronics Engineers
IEL	Industrial Electrotechnology Laboratory
NEMA	National Electrical Manufacturers Association
NPV	net present value
ODP	open drip proof
TEXP	totally enclosed explosion-proof
TEFC	totally enclosed fan-cooled
UL	Underwriter's Laboratory
USDOE	U.S. Department of Energy
VPI	vacuum-pressure impregnation
WSEO	Washington State Energy Office

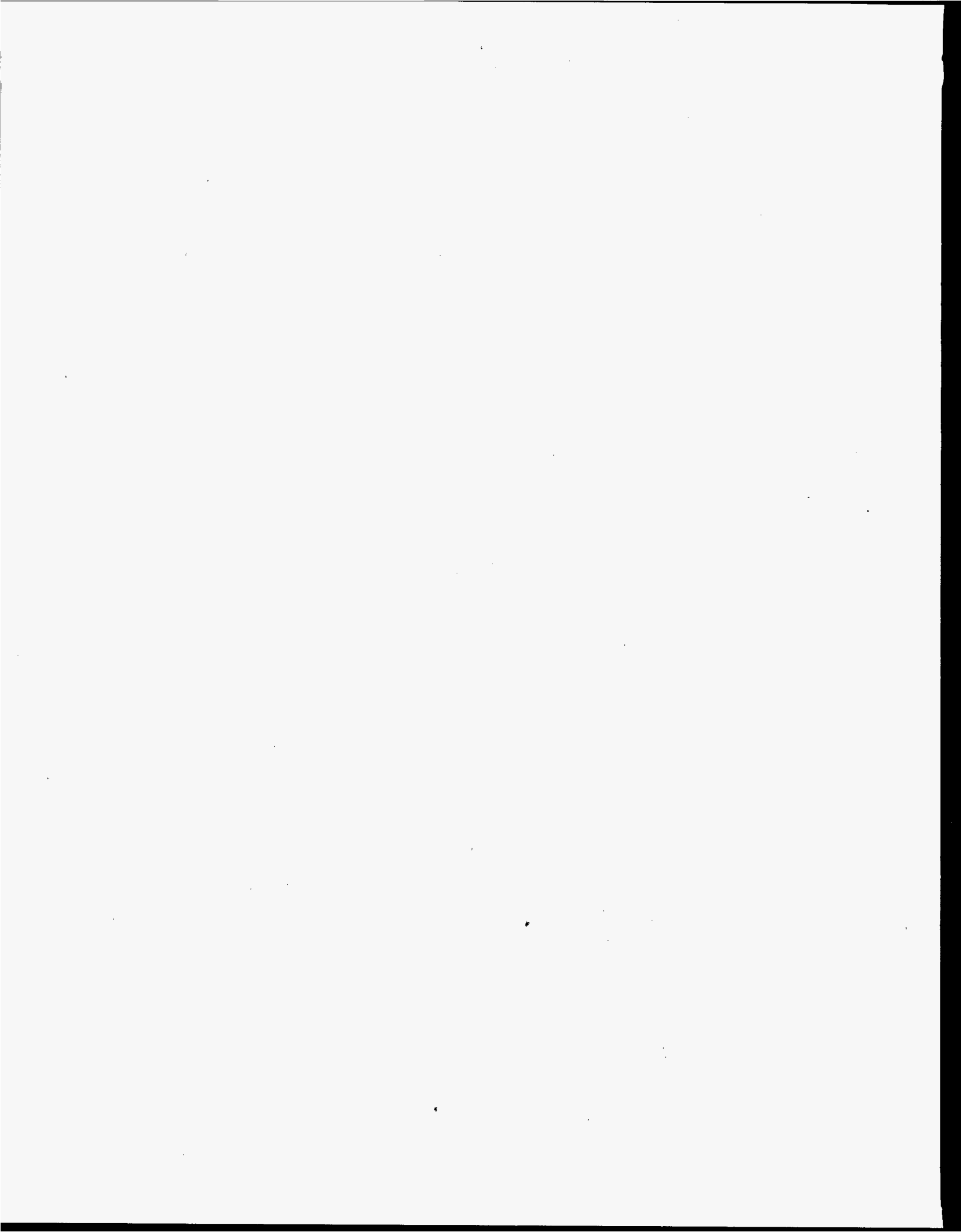

---

# Contents

Preface .....	v
Acronyms .....	vii
<b>1 Introduction .....</b>	<b>1</b>
Motors and the Use of Electricity in the United States.....	1
Changes Affecting the Motor Market .....	2
Why are Repairs and Rewinds Important? .....	3
Quality Motor Repair and Energy-Efficient Performance .....	4
Organization of this Guidebook .....	6
Fact Sheets Designed for Your Use with Your Industrial and Commercial Customers.....	7
<b>2 The Motor Repair Industry .....</b>	<b>9</b>
Services Provided by Repair Shops .....	9
What the Customer Wants—Motor Repair Industry Perspective .....	10
Motor Repair Industry Trends.....	13
Motor Repair Industry Associations .....	14
Standards and Specifications.....	15
Supporting Component and Testing Standards .....	17
<b>3 Understanding When to Repair and When to Replace.....</b>	<b>19</b>
How Will the Decision Affect Downtime?.....	19
Is the Motor Repairable? .....	20
What are the First Cost Differences Between Repair and Purchase?.....	20
How will the Decision Affect Operating Costs? .....	22
What are the Differences in Reliability for a New Versus a Repaired Motor?.....	25
What are the Simple Payback Criteria or Rate of Return? .....	26
Special Issues for Repairing Energy-Efficient Motors .....	27
Putting It All Together .....	28
Rules of Thumb .....	29

<b>4 Barriers to Quality Motor Repair and Rewind.....</b>	<b>31</b>
Educational Barriers .....	31
Financial Barriers.....	32
Infrastructure Barriers.....	33
Technical Barriers.....	33
<b>5 Strategies for Encouraging Quality Motor Repair .....</b>	<b>35</b>
The Overall Strategy: Market Transformation.....	35
Working with the Motor Repair Industry.....	35
Working with Motor Repair Customers.....	37
Working with Manufacturers .....	37
Matching Investments to Utility Benefits .....	38
<b>References.....</b>	<b>41</b>
<b>Appendix A.....</b>	<b>A-1</b>
<b>Motor Basics</b>	
<b>Appendix B.....</b>	<b>B-1</b>
<b>The Motor Repair Process</b>	
<b>Appendix C.....</b>	<b>C-1</b>
<b>How to Determine When to Repair and When to Replace a Failed Electric Motor</b>	
<b>Appendix D.....</b>	<b>D-1</b>
<b>Evaluating Motor Repair Shops</b>	
<b>Appendix E.....</b>	<b>E-1</b>
<b>Selected Bibliography on Electric Motor Repair</b>	

## Section 1

### Introduction

This guidebook provides utilities with a resource for better understanding and developing their roles in relation to electric motor repair shops and the industrial and commercial utility customers that use them. The guidebook includes information and tools that utilities can use to raise the quality of electric motor repair practices in their service territories.

### Motors and the Use of Electricity in the United States

In 1991, more than 1.1 billion electric motors were in operation (EPRI, 1992). The American Council for an Energy Efficient Economy estimates that motors accounted for 57 percent of the 2,700 billion kWh consumed in electric end-uses in 1988. The share of electricity used by motors is especially high in the industrial sector (Figure 1).

Figure 1  
1988 United States Electricity Use By Sector

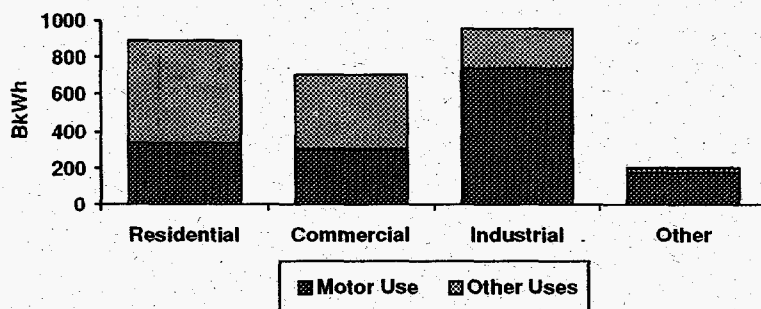

Source: Nadel et al. 1991

Of the motors used in the United States (U.S.), the greatest number, 90 percent, are fractional horsepower motors (motors of less than 1 hp), which are used in kitchen appliances, computers, and office equipment. Eight percent of motors used in the U.S. are 1 to 5 hp motors, and 2 percent are 5 hp or more. Although motors over 5 hp make up the smallest percentage of motors, they account for more than 75 percent of the energy consumed by all motors; not only do these motors require more power *per* motor, they also operate more hours per year (Figure 2).

Figure 2  
Percentage Distribution of 1987 Motor Population  
by Electricity Use and Total Number

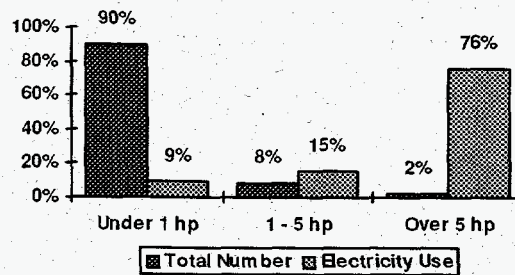

Source: EPRI, 1992

## Changes Affecting the Motor Market

Over 2 million motors over 5 hp are sold in the United States each year. After accounting for motor replacements and retirements, the motor population will increase approximately 2.5 percent annually. The number of energy-efficient motors being sold is also increasing. Energy efficiency is defined by the National Electrical Manufacturers Association (NEMA) standards provided in the association's *Standards for Motors and Generators*, also known as NEMA MG1 (NEMA, 1994). In the most recent revisions to MG1 in October 1994, NEMA defines minimum efficiencies for energy-efficient motors in Table 12-10. These efficiency levels are equivalent to those formerly described in Table 12-6C. In prior versions of MG1, this table was merely a *suggested* standard for *future* design and NEMA set lower, minimum levels for energy-efficient motors (originally Table 12-6B, then renumbered to 12-9 in 1993). NEMA eliminated Table 12-9 in the most recent revisions to MG1, and Table 12-10 became the current standard. Unless otherwise noted, in this report an energy-efficient motor is defined as a motor meeting the current NEMA 12-10 standard.

Of motors currently in production and listed in the January 1994 version of MotorMaster<sup>®1</sup> computer software that lists nearly all motors available in the U.S.), 44 percent meet NEMA's 1994 efficiency standard. An additional 12 percent of the motors meet the former 12-9 standard. In 1990, EPRI estimated that, of all 5 hp motors sold, about 20 percent met NEMA's 12-9 standard. By the year 2000, EPRI estimates that motors meeting NEMA's Table 12-9 standard could account for about 65 percent of new motor sales (EPRI, 1992). National statistics on the market penetration of motors meeting NEMA's current, more stringent efficiency standard are not available. However, estimates indicate that about one-third to one-half of the motors sold that meet the 12-9 standard also meet NEMA's newer standard. Market penetration of energy-efficient motors also varies significantly by region. Fryer and Stone (1993) estimated that energy-efficient motors had a 25 to 30 percent share of new motor sales in four New England states that have aggressive utility rebate programs.

Because of the low turnover in the motor population, energy-efficient motors account for only a small fraction of all operating motors. In a 1993 survey of motor repair

<sup>1</sup> MotorMaster is a registered trademark of the Washington State Energy Office.

shops, the median shop reported that less than 5 percent of the motors they repaired exceeded NEMA 12-9 (Schueler, Leistner, and Douglass, 1994). Only one shop in 15 reported that energy-efficient motors accounted for at least 25 percent of their work. Surveys of installed motors in industrial settings and industry experts place penetration rates of energy efficient motors in 1989 at under 5 percent of the installed motor base (Nadel et. al. 1991).

Utility rebate programs have increased the share of energy-efficient motors in the market. In 1993, more than 160 utilities in over 30 states offered new motor rebates or other incentive programs. In 1994, several utilities have moved to eliminate or reduce motor rebates in response to the higher federal efficiency standards and increased utility competition. Where motor rebates are available these programs encourage motor replacement over repair. Utility rebates move the point where it is more cost-effective to replace a motor than repair it to higher horsepower. The effects of rebates on the repair/replace decision on motor sales are strongest on motors under seventy-five horsepower. Smaller shops feel particularly hard-hit since they are more likely to repair small motors and less likely to sell new motors or have large motor stocks available. Smaller shops are also not able to compete as successfully for sales of new premium-efficiency motors. Manufacturers offer list-price discounts to distributors based on annual sales. Larger volume shops can sell motors at lower prices. If current trends continue, utility motor rebates will become less common, and will play a less significant role in motor buying decisions.

Although most utilities in the United States, with the exception of Virginia Power/North Carolina Power (VP), currently do not run programs to improve and encourage motor repair, interest in such programs is growing. For example, Canadian utilities have initiated an aggressive program to encourage rewind shops to adhere to rigorous quality standards. As a consequence of the Canadian efforts and recently completed assessments by the Electric Power Research Institute (EPRI) and the Bonneville Power Administration (BPA), repair shops have become more interested in strategies for maintaining energy efficiency during repair. The motor repair industry views this interest in energy-efficient repair as a way to maintain market share.

## **Why Are Repairs and Rewinds Important?**

More motor horsepower is repaired than sold each year. In 1993, 2.25 million new motors over 5 hp (totaling between 75 and 100 million hp) were sold in the United States (EPRI, 1993). In the same year, between 1.8 and 2.9 million motors over 5 hp (totaling over 200 million hp), were repaired (Schueler et al. 1994). Although the same number of motors was repaired as was bought new, small horsepower motors were much more likely to be replaced and larger horsepower motors were more likely to be repaired. According to a 1992 study, 33 percent of all failed motors in the New England Region were rewound and repaired, and an additional 9 percent were replaced with used motors. In contrast, 90 percent of motors over 50 hp are repaired (Fryer and Stone, 1993).

Improperly repairing and rewinding motors can decrease the efficiency of individual motors by up to 5 percent. Estimates of the average reduction in efficiency after repair associated with current practice range from 0.5 to 2.5 percentage points, and converge on 1 percent. However, efficiency decreases are not unavoidable or unexplainable consequences of repair or rewinding. Case studies of rewound motors have shown decreased efficiency to be linked to specific shortcuts, errors, or parts substitutions.

In absolute terms, a 1 percent decrease may appear inconsequential, but when the number of repairs and motor operating hours are taken into account, the potential energy and dollar savings are significant. If all the motors under 500 horsepower repaired in

1993 had been repaired with no efficiency losses, motor electric energy use would have *decreased* by between 200 and 300 average megawatts (aMW)<sup>2</sup> a year. If all repaired motors currently in operation had been repaired with no decrease in efficiency, savings would be about 2,000 aMW, roughly equivalent to the output of two large thermal power plants.

Maintaining energy efficiency during repair usually improves motor performance and reliability after repair, significantly contributing to the productivity and competitiveness of motor repair customers. And because motors whose efficiency has decreased by more than 5 percent during repair are more likely to fail early, maintaining energy efficiency may also save the cost of early replacement. By working with the motor repair industry, utilities can provide information and services critical to helping industrial and commercial customers manage their energy use and improve productivity. Providing these types of services and education will become more essential as the utility industry faces increasing competition for customers.

### **Quality Motor Repair and Energy-Efficient Performance**

At its most basic level, the goal of "energy-efficient" repair of motors is to return the motor to original manufacturer specifications in a manner that does not decrease efficiency. Although maintaining energy efficiency during motor repair is a process consisting of many small steps, there are two major elements of the process:

- avoiding the shortcuts, errors, parts substitutions, and other practices that decrease efficiency, and
- diagnosing potential sources of decreased efficiency by appropriate testing before and after repair.

It is not surprising that the Canadian utilities, which lead efforts to reduce efficiency decreases during repair, have found a strong link between shop quality assurance efforts and the likelihood that motors will be repaired without decreasing efficiency. To emphasize this critical link, Canadian utilities refer to their programs as quality motor repair and their goal as quality motor repair. By encouraging and supporting quality assurance and quality repair, efficiency losses can be reduced and the reliability of re-wound and repaired motors improved in a manner that delivers energy savings and supports a strong motor repair industry. For many motor repair customers and utilities, the improved reliability and related productivity gains associated with quality repair are more compelling than the energy benefits.

---

<sup>2</sup> An "average megawatt" (aMW) is equal to one megawatt of capacity produced continuously over the period of one year. (1 megawatt x 8,760 hours in one 365-day year) = 8,760 megawatt hours or 8,760,000 kilowatt hours.)



## Listing Key Terms and Definitions

### **Baking**

Pertains to the process and equipment for heat curing insulating varnish. It should not be confused with "burn out" which is the term for destroying insulation on old windings to facilitate their removal.

### **Burn out**

"Burn out" refers to the process of controlled heating of old windings to burn off insulation to facilitate their removal. Burn out ovens should not be confused with baking ovens used at lower temperatures for varnish curing.

### **Core loss testing**

Method of testing the iron stator core for degradation that can lead to decreased motor efficiency. This is done by applying a magnetizing current to the core, observing power consumption, and checking for hot spots. When this testing is done with standard electrical testing equipment, it is usually called a loop or ring test. Special core loss testers are becoming popular for simplifying testing.

### **EASA**

Electrical Apparatus Service Association - This is a voluntary trade association of businesses which repair motors and other electrical apparatus.

### **Efficiency**

Motor efficiency is the output over input, i.e. the mechanical shaft power divided by the electrical input power with both expressed in the same units. Efficiency is difficult to measure and varies with the conditions of operation and from motor to motor within the same model. Standard procedures exist for measuring motor efficiency. NEMA regulates how efficiency is to be measured and reported on motor nameplates. NEMA specifies that IEEE standard 112B be used for the measurement of efficiency. When motors are repaired, excessive temperatures, or failure to replicate original design conditions can decrease efficiency.

### **Explosion proof**

Motors designed to safeguard against igniting a specified gas or vapor in their ambient environment, even if an explosion of that gas or vapor occurs inside the motor. Shops that repair explosion proof motors must be certified by Underwriters Laboratories (UL).

### **Form wound**

There are two coil winding methods, form and random. Form wound coils are usually used on motors over 500 HP and over 600 volts. Wire of rectangular cross section is wound into orderly layers, shaped on a special jig, then wrapped with special insulation before being inserted as a rigid assembly into rotor or stator slots.

### **IEEE**

Institute of Electrical and Electronics Engineers - One function of this professional association is creation and promulgation of standards for the repair and testing of electrical apparatus.

### **Induction motor**

The most common type of motor is the 3 phase AC induction motor. This is a relatively inexpensive design which requires no brushes or other electrical connection to the rotor. Standard size and performance parameters are defined by NEMA. NEMA provides a definition of energy efficiency for 3 phase AC induction motors, of Design A and B torque performance, between 1 and 200 HP.

### **Insulation class**

All materials used as electrical insulation in a motor are classed by the maximum temperature they can endure. Classes are A, B, F, and H, each successively designating a higher temperature. The overall motor classification is equal to that of the lowest classed component.

### **ISO**

International Standards Organization - Federation of national standards bodies with a mission to facilitate trade and foster international cooperation by promoting worldwide standardization. ISO vibration standards and quality control standards are important standards pertaining to motor repair.

### **NEMA**

National Electrical Manufacturers Association - This association defines standards for the manufacture, testing and rating of electrical apparatus. Any motor called "energy efficient" must equal or exceed certain values set by NEMA.

**Random wound**

There are two coil winding methods, random and form wound. Random wound coils (sometimes called mush wound) are usually used on motors under 500 HP and under 600 volts. Multiple turns of round wire are wound into loops and inserted into slots in a rotor or stator.

**VPI**

Vacuum Pressure Impregnation. This is a method to ensure thorough penetration of insulating varnish into windings. The motor is placed in an air-tight varnish tank. First a vacuum is applied to draw out air that could form bubbles. Then pressure is applied to force varnish into all spaces within windings.

**Repair**

All service to motors whether or not rewinding is performed.

**Inverter**

Motors are often powered by variable frequency drives to vary their speed. These drives work by converting 60Hz power to DC then back to AC at other than 60Hz. The circuitry that recreates the AC is called an inverter. This circuitry applies an imperfect AC sine wave to the motor and this can cause stresses. Some new motors are especially designed for inverters. Special materials or methods are sometimes required when rewinding a motor that will be powered through an inverter.

**Rewind**

Replacement of windings on either rotor or stator. Rewinding is usually part of an extensive motor repair that also includes mechanical work.

**Rotor**

The rotating part of a motor including everything mounted on the shaft.

**Stator**

The stationary magnetic part of a motor in which the rotor turns.

**Surge tester**

A multi-purpose test device used in motor shops for testing insulation integrity, winding resistance, and phase symmetry. The surge tester consists of a voltage impulse source and a scope to observe motor response.

## Organization of this Guidebook

Section 2 outlines the motor repair market in the United States. The section describes the structure of the industry the factors that influence decisions to repair/rewind, and the criteria used to select a specific motor shop to do the work. This section also summarizes recent research and technology trends and market changes influencing quality repair. A discussion of influential industry associations and motor repair standards is included as well.

Section 3 addresses the question, "When should a motor be repaired?" This is a critical question that electric utilities need to understand when advising their customers.

Section 4 identifies the barriers to quality motor repair.

Section 5 covers the strategies and interventions utilities have at their disposal to encourage quality motor repair.

## **Fact Sheets Designed for Your Use with Your Industrial and Commercial Customers**

Appendices A through D are reproducible fact sheets. Each covers a technical topic on motors and motor repair. You are encouraged to reproduce these fact sheets. They may be used as is or modified to include more specific local utility information. Include them in motor rebate application packages and distribute them during facility audits. Use them as handouts at conferences or training events. The appendices contain the following information:

- *Appendix A, Motors and Motor Efficiency*, is a primer on basic motor facts.
- *Appendix B, The Motor Repair Process*, is a step-by-step description of what happens during motor repair.
- *Appendix C, When to Repair—When to Replace*, identifies the factors a motor user should consider when deciding when to repair or replace a failed motor. Offers rules of thumb for when it is cost-effective to repair a motor.
- *Appendix D, Choosing A Quality Repair Shop*, outlines what the repair customer should consider in choosing a quality motor repair shop. It includes specific questions all motor repair customers should ask motor repair shops.

Appendix E is an annotated bibliography of important references on motors and motor repair. It's an important source of information for those interested in a more detailed discussion of the issues summarized in the guidebook.

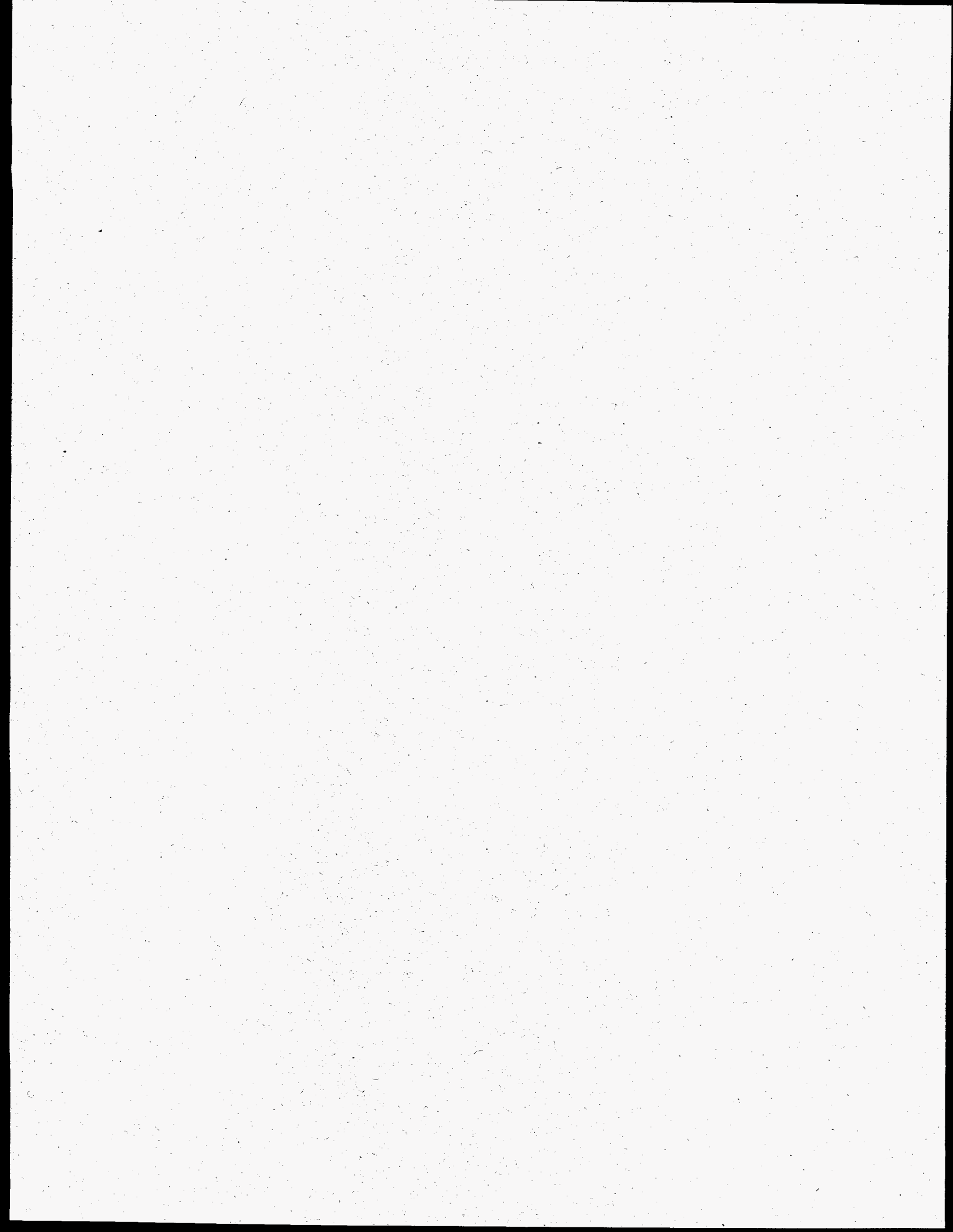

## Section 2

# The Motor Repair Industry

There are approximately 4,100 motor repair shops in the United States. Motor repair shops are very stable and are often family businesses. Most have been in business 25 years and larger shops have longer business histories. Although most of these shops are independently owned businesses which are not affiliated with manufacturers, some manufacturers including General Electric, Westinghouse, and Reliance still own repair shops. These manufacturer-owned repair shops repair motors for all manufacturers.

The motor repair industry is dominated numerically by small shops; however, larger shops have the biggest dollar share of the market as they are likely to repair more and larger motors. Seventy-five percent of the shops had 9 or fewer employees, and these smaller shops repaired 45 percent of the total motors and 25 percent of the total horsepower (Figure 3).

In 1993, motor repair shops repaired between 1.8 and 2.9 million motors totaling over 200 million horsepower. These shops had \$2 billion in gross annual motor repair revenues, over 70 percent of the shops' revenues from all sources (\$2.75 billion). As a point of reference, NEMA's members—which are companies that manufacture products for the generation, transmission, distribution, and use of electricity—have annual shipments for all products of approximately \$100 billion.

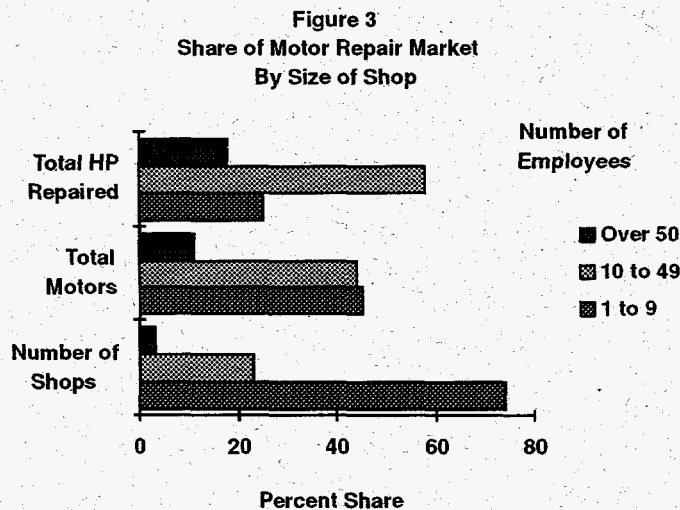

## Services Provided by Repair Shops

Almost all repair shops provide some services other than motor repairs and rewinds. Ninety-five percent of shops interviewed in 1993 sold new motors. Eighty percent sold or serviced other electrical equipment.

Although repair shops provide other services, motor repair accounts for 70 percent of gross revenues. Non-repair services contribute a larger share to the revenues of larger shops. In shops employing more than 50 people, motor repair generates 50 percent of gross revenue, compared with 70 to 75 percent for smaller shops. One reason for this difference is that small shops are less likely to sell or service electrical equipment other

than motors. Half the smaller shops sell and service equipment other than motors, compared with nearly all of the larger shops. Fifty-four percent of the shops contract out some work. Machine work, formed coils, balancing, and small armature work was contracted out most frequently.

Most shops repair motors for a broad spectrum of industrial and commercial clients. At the same time, many shops develop application or industry-specific expertise in which much of their business is concentrated. Smaller shops are more likely to work in the commercial, agricultural, and general-manufacturing sectors. Large shops dominate transportation, manufacturing, and heavy industry sectors. This is not surprising since motors in these sectors are larger and more complex and require equipment and expertise small shops do not have.

Two-thirds of the shops provide planned maintenance and inspection services to some clients. According to one motor repair customer, many of the motors sent out for planned maintenance do not get repaired. Most are sent for cleaning, inspection, and balancing (Nailen, 1993). Planned maintenance accounted for 5 percent of the total motor service business for the median size repair shop. Large shops are more likely to service motors on planned rotation. Almost one-quarter of the motors serviced in shops with more than 15 employees are on planned maintenance. Planned maintenance accounts for only 10 percent of the motor repair market.

### **What the Customer Wants — Motor Repair Industry Perspective**

In a 1994 survey (Schueler et al.), 65 motor repair shops were asked to rate the importance of factors their customers use to select a repair shop. The shops used a four-point scale where one indicated that the factor is not important and four indicated that it is very important. Ratings are summarized in Table 1.

Three selection criteria were rated as very important by almost all the shops; these criteria are factors that *all* shops feel their clients value and understand: fast turn-around time, quality control and reliability, and technically skilled and expert staff.

Three selection criteria were rated very important by about half of the respondents; these criteria were factors the shops feel are important and understood by some of their customers: the range of repair services offered, the quality of material used, and the length of the working relationship. Large shops were significantly more likely to rate the quality of materials and range of service as very important to their customers.

Low cost was rated very important to customers by only one-third of the shops. This low rating may reflect the fact that the shops' associate low cost with poor quality; it may also reflect the shops' perception of the criteria customers *should* use to select repair shops. It was evident in comments throughout the survey that most shop owners have a strong craftsman ethic and pride in getting good work out despite the rapid turn-around times required by their customers. Shops understand that when a critical component fails, it must be returned to service as quickly as possible, regardless of the cost, to avoid even more costly downtime for their customers. Finally, the low rating for costs does not mean that shops are not aware of the pressure to reduce costs relative to replacement or that cost issues are not important to clients. Instead, it means that once the decision to repair is made, shops believe that clients are willing to pay to have repair done right and on time.

Information and reporting on motor repairs and training support services were rated the least important services to customers, although larger shops were more likely to rate these factors as more important.

Those interviewed indicated that customers did not choose shops based on their ability to maintain energy efficiency during repair or the shops' experience repairing energy-efficient motors. The maintenance of energy efficiency was not introduced as a rated factor in the questionnaire and none of the respondents mentioned it unaided.

Shops reported that customers seldom provide any repair specifications, much less specifications for maintaining energy efficiency and that their clients often do not have the information or background to identify and specify quality motor repair work. Only 15 percent of motor repair shops surveyed indicated they very often or somewhat often get repair specifications beyond the requirement to return the motor to its original condition. Of those shops that did report receiving customer specifications, the most common specifications were for insulation levels, varnish, winding patterns, or for meeting special operating conditions. Detailed specifications for motor repair of any type are the exception, rather than the rule. No shops reported customer specifications for maintaining energy efficiency.

**Table 1**  
**Motor Repair Shop Ratings of Reasons**  
**Their Customers Choose Repair Shops**  
**1 = Not Important      4 = Very Important**

<i>Factor</i>	<i>Number of Responses</i>	<i>Average Rating</i>	<i>Percent Rated Very Important</i>
Fast Turn-around time	65	3.78	82%
Quality control/reliability	65	3.78	82%
Technical skills/staff expertise	65	3.71	72%
Range of repair service offered	65	3.52	57%
High quality materials/components	65	3.35	55%
Length of working relationship	65	3.32	52%
Low cost	65	3.11	32%
Information and reporting on repairs	64	2.56	20%
Training and support services	62	2.40	14%

## **Recent Developments**

### **New Research Initiatives**

*Core-loss Testing.* Much interest has been directed toward core-loss testing. Core defects cause local or generalized overheating in the core, which may increase energy losses and shorten winding life. Core-loss testing is still primarily used to excite the core electromagnetically so that local damage like lamination shorting could be detected as hot spots. This is certainly useful, but core-loss testing also holds the promise of assessing the overall health of the stator iron both before and after winding removal. This assessment would allow repairers to determine first if the motor was worth repairing, then to document whether the combination of winding removal and repair improved or degraded the core condition. Both of these determinations are valuable information to the repairer and customer.

The Canadian Electrical Association and LTEE Laboratories of Quebec have been researching performance of core-loss testing using commercial core-loss testers and standard electrical shop equipment; this work is still in progress. The Brook Compton

Company in Great Britain is doing related research. Little has been published at this date, but some general facts are emerging:

- Core-loss test methods do not excite the core identically to the actual stator winding with a rotor in place. Therefore, core losses in watts per pound, while related to core condition, are not identical to losses that occur when the stator is operating in a motor. The future may bring other tester configurations that attempt to simulate the radial magnetic flux through rotor teeth which occurs during motor operation.
- The interlaminar core leakage is very sensitive to many conditions that can change quickly or inadvertently. These conditions include tightness of core compression, impacts, exposure to corrosive or oxidizing conditions, and small surface scratches or smears from machining or sanding.
- The observed core losses may vary depending upon the design and accuracy of the devices used for measurement.
- Measuring a motor's actual core loss is only part of the challenge; assessing the significance of that loss level is another. Very little manufacturer data currently exist to identify expected or acceptable losses of a healthy stator. The acceptable level depends not only upon weight, but on other details of the iron and core construction, which are generally known only to the manufacturer.

Ongoing research may lead to standardization of core-loss test methods, and documentation and publication of individual motor core-loss service limits.

*Innovative Wire Enamel.* In many applications, very large savings can be reaped by varying motor speed with a variable frequency drive. Modern drives place a great deal of voltage stress on winding insulation because of the way they simulate the AC voltage wave. Instead of a rising and falling sine wave, they work somewhat like a digital audio recording. Voltage is switched or pulsed fully on or off approximately 20,000 times per second. Because of the finite speed of electric current, a sharp pulse reaches the first turn of a coil before it reaches the rest. This causes a high turn-to-turn potential that can cause the thin enamel wire insulation to fail.

Products are being developed to address this sort of turn-to-turn failure. At present, they generally involve better enamel insulation or heavier coatings. The film build-up in wire film insulation comes in different thicknesses—single-build, heavy build (for double-build) and triple-build are some examples. NEMA standards prescribe film thickness for a given conductor diameter. As new products become available, choice of film thickness may reduce turn-turn failure.

Coatings with other materials might yield better mechanical strength or corona resistance. The extra thickness of film coatings in current use, which may offer a partial solution to turn-to-turn failure, displaces space for copper in the stator slots. Motor and wire manufacturers and motor repairers are working to find optimal solutions to this problem.

### **Technology Trends**

*Machine Winding.* Many new motors are factory-wound by machines that insert coils in the slots. These machines generally use a concentric arrangement of coil groups which some shops find more difficult to prepare or insert. Also, the machines often achieve a tighter slot fill than manual methods can.



Machine insertion is not practical for motor shops because the machines have to be designed and configured to a specific single product line. Machine insertion is part of the reparability issue. Repairers and sophisticated motor users are asking manufacturers to build a motor that can be repaired to factory performance.

*Shop Equipment.* The equipment used for repairing motors has changed little over many years. It remains a process of manual labor where craftsmanship and an abundance of practical experience are essential for product quality. And much of a repair shop's work does not seem readily adaptable to more modern methods; the microcomputer has not even made it into many shops.

As a counterpoint, some in the repair industry feel repair methods are indeed amenable to modernization. They maintain that more inventive energy should be applied to the challenge. Significant advances have certainly been made in testing methods and equipment. Commercial core-loss testers are one example. Surge comparison testers have become a valuable tool for performing a variety of diagnostic and verification tests. Many shops have upgraded their power supply capability by constructing variable voltage transformers from surplus wound rotor induction motors. Sophisticated computerized vibration monitoring equipment is being used in some shops for rotor balancing equipment and for bearing diagnosis and even electrical diagnosis.

Much of the equipment developed in recent years has improved the *potential* for a good diagnosis and quality repair, but innovations for saving labor are sorely needed. One technology that has the potential for labor saving is information technology. A frequently updated on-line or diskette based data file on motor rewinding information is needed. Much time is wasted by repairers figuring out a motor's existing configuration, e.g., bearing types; winding patterns, turns, gauge; acceptable core losses, no load current, winding resistance; etc. A universal data base of these parameters should be prepared for at least all motors in current and future production.

## **Motor Repair Industry Trends**

The motor repair industry is in a state of transition. In a 1993 member survey sponsored by the Electrical Apparatus Service Association (EASA), the primary industry association of the motor repair industry, almost 75 percent of those surveyed reported their profitability had decreased over the past 2 years. Shops attributed decreased profitability to increasing labor costs, a decreasing market for repair work, high-tech specifications, increasing costs for meeting government regulations, and customers with more sophisticated demands for services (Brutlag and Associates, 1993).

One reason the market for motor repair is declining is that the break-even point for replacing rather than repairing motors is shifting to larger motors. According to Mehta (1994), the shift in the repair/replace decision point appears to be driven by increasing repair labor costs. In high-priced labor markets such as Hawaii, the break-even point may be as high as 40 to 50 hp.

The motor repair shops surveyed in 1994 mirrored these concerns. (See Schueler et al., 1994). When asked to describe the major challenges facing them, shops most frequently mentioned the general shift from motor repair to replacement, the eroding U.S. industrial base, increasing costs of complying with government regulation, and increasing labor and equipment costs (Table 2).

**Table 2**  
**Major Challenges Faced by the Motor Repair Industry**

<i>Survey Respondents (multiple responses accepted)</i>	<i>(N=62)</i>
Technology change/Shift to motor replacement	24%
Low cost new motors	21%
Weak economy/Declining industrial base	18%
Environmental/Government regulations	18%
Increased costs for labor, equipment and materials	16%
New energy efficiency standards	10%
Competitive market	8%
Other	19%

Repair shops are under tremendous pressure to reduce costs, improve quality assurance and technical services, and reduce lead times. At the same time, the mix of motors that shops are asked to repair is changing with increased market penetration of energy-efficient motors.

### **Motor Repair Industry Associations**

Several organizations exert strong influence on motor repair practice and standards. Industry associations and standard-setting organizations are allies for utilities interested in improving the quality of motor repair. This section outlines key players and resources. Much of the material here is extracted from the *Electric Motor Systems Source Book* (EPRI/BPA/DOE, 1993).

#### **Electrical Apparatus Service Association**

The primary industry association in the motor repair industry is the Electrical Apparatus Service Association (EASA). Slightly under half (47 percent) of motor repair shops are members. Eighty percent of medium-sized shops (with 10 to 50 employees), which are the backbone of the motors repair industry, are members. EASA is not as well-represented among smaller shops (those with 10 or fewer employees) and very large shops (over 50 employees). Shops with membership in EASA repair 65 percent of total motors and 75 percent of total horsepower. The reason: much of the nation's motor repair work is done by the medium-sized shops that make up the majority of EASA's membership.

EASA provides its members with publications, computer programs, and training seminars designed to improve the quality of their motor repair practice. The association's publications include fact sheets and technical notes on best repair practices and extensive databases of rewind specifications. Its computer programs cover such topics as motor redesign, winding, and turn calculations. EASA also sponsors research, such as the *Core Iron Study*, and publishes an annual membership directory listing members by state and city. The directory includes good basic information on the capabilities, services, and equipment of listed shops. It is a valuable resource for locating rewind shops in utility service territories.

EASA has been active in working with shops to improve motor repair practice. Among its recent efforts is the EASA - Q: *Quality Management System for Motor Repair*, a detailed written quality management system for quality motor repair. (EASA-Q is discussed in more detail later in this section.)

EASA's national office is headquartered in St. Louis. The association has over 30 local U.S. chapters listed in its membership directory. Contact EASA by writing to: EASA; 1331 Baur Blvd., St. Louis, MO 63132, (916) 993-2220.

Key EASA contacts are: Wally Brithinee for engineering matters, (909) 825-7971, and Dave Gebhart for organizational matters, (314) 993-2220.

### **National Electrical Manufacturers Association**

NEMA is a non-profit association of manufacturers of electrical apparatus and supplies. It has more than 600 member companies that manufacture products for the generation, transmission and distribution, control, and end-use of electricity. One of its primary missions is to develop standards for products using electricity. NEMA develops and publishes many of the standards pertaining to motors and drives, and it collates statistics on motor sales and other issues. NEMA standards are intended to assist users in the proper selection and application of motors and generators. They provide guidance on performance and construction, safety, and testing procedures, and they are used to determine which motor efficiency levels are deemed energy efficient. Contact NEMA by writing to: NEMA, 2101 L Street NW, Suite 300, Washington, DC 20037.

### **Institute of Electrical and Electronics Engineers**

The Institute of Electrical and Electronics Engineers (IEEE) is a non-profit professional society for electrical engineers. IEEE is a leader in developing and disseminating industry standards on electric motors and related materials. IEEE standards cover both general practices, such as energy conservation practices in general facilities, and detailed test procedures. The IEEE materials most applicable to motor repair practice are motor testing standards, such as *IEEE Standard 112 Test Procedure for Polyphase Induction Motors and Generators (1991)*. IEEE Standards can be ordered from: IEEE Customer Service, 445 Hoes Lane, P.O. Box 1331, Piscataway, NJ 08855-1331 (800) 678-IEEE).

### **Standards and Specifications**

Two types of standards are of interest for the motor repair industry: standards for motor repair, and repair-related procedures and standards for motor efficiency testing. Motor efficiency testing standards, such as the IEEE Standard Test Procedures, provide very detailed information on testing procedures, testing equipment, and calculations. While they inform shop-floor practice, they are designed more for use in laboratory settings. They do not describe when tests should be performed in a repair setting and what critical readings are.

Motor repair standards cover a wide range. There is a strong framework of general quality assurance standards in the repair industry, as well as strong standards covering specific aspects of motor repair. The major weakness of these standards is that they are either very general or very detailed and complex. In either case, they may not transfer well to the shop floor or to the motor repair customer. There are no model industry standards or specifications which focus exclusively on the energy-related aspects of motor repair, with the possible exception of IEEE Standard 1068-1990, *IEEE Recommended Practice for Repair and Rewinding of Motors for the Petroleum and Chemical Industry*. Most motor repair experts believe that existing standards provide a sufficient framework, and developing new standards is not warranted. The critical need is to develop tools and methods to communicate essential elements of standards clearly and

effectively and incorporate energy efficiency considerations in these standards. The 1994 EPRI and BPA *Model Repair Specifications* are designed to meet this need. The remainder of this section describes this standard and other relevant standards and specifications.

### **EPRI and BPA Electric Motor Model Repair Specifications**

The Washington State Energy Office is currently compiling *Model Repair Specifications for Electric Motors*. The specification draws from the best of repair specifications currently available. These repair specifications outline recommended minimum requirements for the repair and overhaul of polyphase, alternating current (AC) squirrel cage induction motors. The specifications recommend procedures for inspection, winding removal, repair, testing, quality control, and documentation. These model specifications can help motor repair customers to communicate expected levels of performance to repair shops. The specification also includes sample forms for submitting repairs and reporting key test results. These specifications are currently in review and should be available in early 1995.

For information on obtaining copies of the specifications contact the Energy Ideas Clearinghouse at the Washington State Energy Office.

### **EASA-Q: Quality Management System for Motor Repair**

In 1993, EASA completed broad quality assurance specifications for motor repair shop operations, known as the EASA-Q Quality Management System. EASA-Q incorporates all the elements of the International Standard Organizations (ISO) 9002-1994 Quality Management Standard. EASA-Q covers all phases of motor repair shop operation including management responsibilities, record keeping, process control, equipment inventory and calibration, training, safety and performance measurement. Certification of compliance to entry level of the EASA-Q system is determined by inspection by an independent third party using a detailed check list. Level I and II certification is based on customer survey results and warranty costs as a percentage of total sales.

EASA-Q certification is strong evidence, though not a guarantee, that a shop is likely to provide quality motor repair services. At this time the EASA-Q Quality Management System does not comprehensively address issues related to maintaining energy efficiency during repair. However, the EASA-Q system may be updated to address these issues in the future.

Some non-EASA shops report that they have developed their own independent quality assurance standards. These are typically developed on a case-by-case basis. These should be requested and compared to the EASA standards to ensure they are comprehensive.

### **International Standards Organization - ISO 9002-1994 Quality Management Standard**

The ISO 9002 Quality Management Standard is widely accepted in the industry as the framework for Quality Assurance Standards. The ISO standard lists the essential elements quality assurance standards should include. If a repair shop indicates that it does have a quality assurance standard and procedures, other than EASA-Q, staff should be asked if the standard conforms to ISO 9002. The ISO standard can be exceeded and

additional elements included. For example, the EASA-Q standard includes additional practical guidelines and information specifically targeted to motor repair issues.

ISO does have a certification process. Fees for certification can total several thousand dollars. As a final note, ISO certification does require that all essential elements of a quality assurance program are in place, but does not guarantee a quality motor repair.

## **Supporting Component and Testing Standards**

Quality assurance standards incorporate references to specific testing and component standards developed by industry and professional associations including Underwriters Lab (UL), IEEE, NEMA, and the American Bearing Manufacturers Association (ABMA). These standards govern specific elements of the repair process and repair requirements for specific applications. Essential supporting standards include:

### **ABMA**

Standard 7 : *Shaft and Housing Fits for Metric Radial Ball and Roller Bearings*

### **IEEE**

Standard 43 *Recommended Practice for Testing Insulation Resistance of Rotating Machinery*

Standard 112 *Standard Test Procedure for Polyphase Induction Motors and Generators*

Standard 522 *Guide to Testing Turn-to-Turn Insulation on Form-Wound Stator Coils for Alternating Current Rotating Electric Machines*

Standard 1068 *Recommended Practice for Repair and Rewinding of Motors for the Petroleum and Chemical Industry*

### **NEMA**

Standard MG-1 *Motors and Generators*

### **UL**

Standard 674 *Electric Motors and Generators for Use in Hazardous Locations*

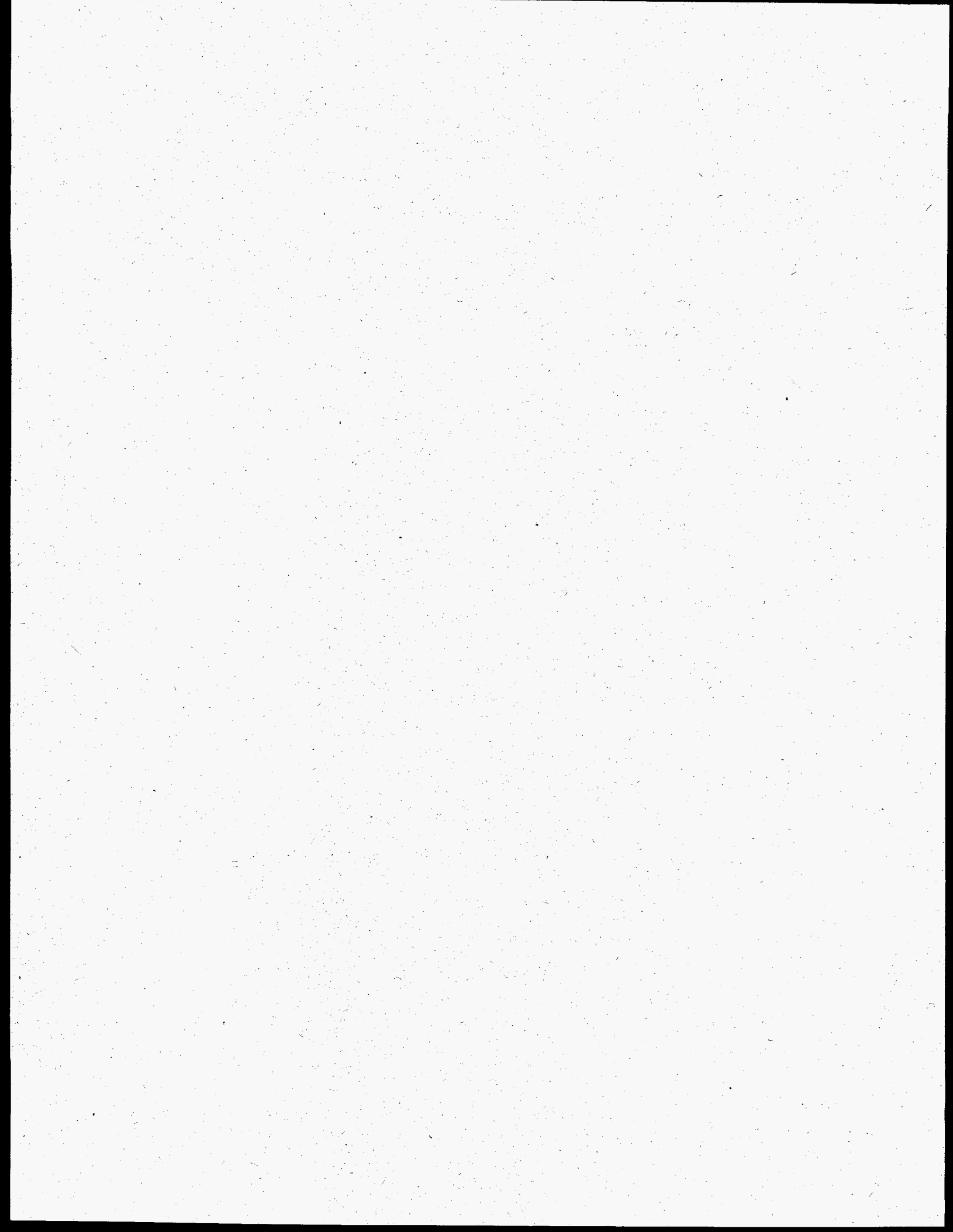

## Section 3

---

# Understanding When to Repair and When to Replace

When a motor fails, the first decision the motor user faces is whether to repair or replace the motor. By helping industrial and commercial customers understand the complex issues associated with this decision, utilities can provide a useful service to customers while achieving energy-efficiency and load management goals. Key considerations in deciding whether to repair or replace a motor include:

- How will the decision affect downtime?
- Is the motor repairable?
- What are the first cost differences between repair and purchase (the first cost for repair is the repair price only; the first cost of motor purchase is purchase price only)?
- How will the decision affect operating costs?
- What are the differences in reliability for a new versus a repaired motor?
- What are the simple payback criteria or rate of return?

In this section we outline these considerations and the ways in which they interact. As a motor-specific analysis can be time consuming, we identify rules of thumb to determine whether a more detailed analysis is needed. Finally, we discuss special issues related to the repair or replacement decision for energy-efficient motors.

## How Will the Decision Affect Downtime?

From the motor user's perspective, one of the most important considerations in deciding whether to repair or replace is which option causes the longest production downtime. This consideration is especially important if a motor drives a critical production process or piece of equipment and no back-up motors are available. In industrial facilities the costs of lost production often exceed the differences in costs between repair and replace options. Out-of-service costs are also significant, though they are sometimes more difficult to measure in commercial sector applications.

Either option, repairing or replacing the motor, can be faster. A typical turnaround time for repairing a 50 hp motor, assuming parts are readily available and no machining is needed, is approximately three working days. A rush order, which commands a 20 percent premium, can decrease turnaround to two calendar days. Turnaround time may increase by a day or two for motors over 200 horsepower because of longer burn-out times, longer times needed for winding and other repair processes, and the need for subcontracting tasks like formed coil work.

If the user decides to replace the motor, the primary issue is whether the replacement is in stock and available off the shelf. Most general purpose open drip-proof (ODP) and totally enclosed fan-cooled (TEFC) motors under 100 hp are usually available off the shelf. Non-specialty motors between 100 and 500 hp are often in stock at the

manufacturer and can be rush ordered and delivered by rail in two to four working days. Specialty motors (low-speed, vertical, high-slip, wound rotor, and multi-speed motors) and motors over 500 hp are less likely to be available either at the motor distributorship or at the manufacturer. They may take up to several weeks to replace depending on the specification. These motors also fall outside the categories affected by efficiency legislation and most utility rebate programs, so replacements that are significantly more efficient may be hard to find or prove. Therefore, specialty motors are more likely to be repaired than replaced.

A final factor that affects the downtime calculation is whether backup motors are available. The availability of backup motors is facility-specific. Motor users are likely to keep spares on hand for critical and commonly used motors. To keep inventory costs down, they are unlikely to keep spares on hand for all motors, particularly larger ones.

Time pressure is less of a factor for motors that are inspected and serviced under planned maintenance programs. Many of these motors are not repaired. They are cleaned, inspected, and balanced. Two-thirds of the repair shops offer planned maintenance services, but planned maintenance currently accounts for only about 10 percent of the motor repair market. Nevertheless, the market share for planned maintenance is increasing.

### **Is the Motor Repairable?**

Almost any motor that has failed can be repaired. The real question is, "At what cost?" The majority of motor failures consist of seized bearings, winding burnout, and broken fans. These problems usually require routine repairs. They are not typically fatal; that is, they do not require that the motor be replaced. Life-ending failures are much less frequent. These failures include such problems as holes melted in the stator core, cracked rotor bars, and bent shafts, although in many cases even these problems can be repaired. The costs for machining or restacking cores may be prohibitive, however.

Except in extreme cases, it is difficult for untrained persons to determine by casual inspection whether the problems of a failed motor are routine or serious. In many cases, determining whether a motor is repairable cannot be made without dismantling the motor. As a courtesy to customers, repair shops have historically provided this service at little or no cost. The cost of providing this service, particularly if a motor is not repaired or is repaired elsewhere, is a growing burden for shops. As a result, many shops now charge for disassembly and testing; cost ranges from \$75 to \$400 depending on frame size. If the other economics of a repair decision are marginal, the complexity of the required repair may be a deciding factor.

### **What are the First Cost Differences Between Repair and Purchase?**

The difference between the cost of buying a new motor and cost of repairing and re-winding an existing motor is the second biggest factor influencing the repair/replace decision. This difference is not uniform across motor size and type, however. Considering only first cost, it is more economical to repair than to replace larger horsepower motors and specialty motors.



## The Impact of Horsepower on First Costs

For non-specialty motors under 10 hp, it is more expensive to rewind than to purchase new. However, the cost to rewind a 100 hp motor is about one-third the cost of a new motor. To illustrate this, we have compared the ratio of rewind costs to new purchase price for 1800 RPM TEFC T frame motors using data from *Vaughen's 1994 Pricing Guide* (Figure 4). In this example, new motor costs include a dealer discount. Two rewind options are examined: a minimal rewind, and a rewind that includes some minor additional repair work (furnishing and installing two standard bearings and nine new leads). The second option is more common (Lammers, 1994). The point below which it is more costly to replace rather than rewind a non-specialized motor is between 5 and 10 hp (Vaughen's, 1994). If any additional repairs are needed, this point is between 10 and 20 hp.

Motors are often not repaired unless repair and rewind costs are less than 50 to 75 percent of the cost of a new motor. The energy savings realized from buying a premium-efficiency motor over standard efficiency combined with utility rebates shifts the replacement break-even point to larger horsepower motors. However, price premiums for new specialty motors move the break-even point to smaller hp motors. It is more economical to rewind larger horsepower motors because new motor costs increase much more quickly with horsepower than rewind cost. A new 500 hp, 1,800 rpm, TEFC motor costs 30 times what a similar 25 hp motor costs. However, rewinding a 500 hp motor is only 10 times the cost of rewinding a similar 25 hp motor.

Industry observers report that the break-even point for purchasing new motors is shifting to larger motors (Mehta, 1994). There is some consensus that this trend will continue because of increasing labor cost for motor repair. New motor costs are also expected to decrease because of offshore production in Mexico and elsewhere and decreases in tariffs. In some high labor cost markets, it is now common to automatically replace instead of rewind motors up to 50 hp.

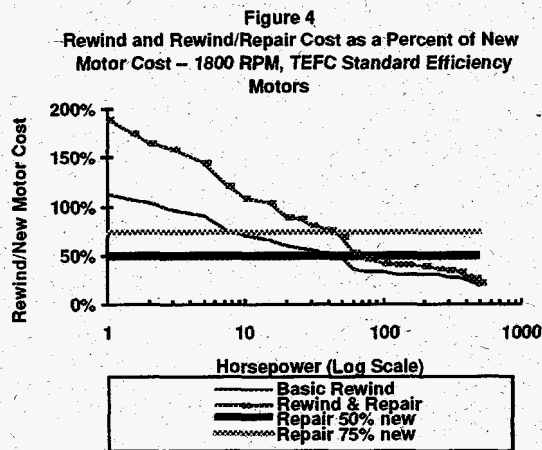

## The Impact of Motor Type and Speed on First Costs

The costs of rewinding or purchasing also vary significantly by both motor type and speed. As with horsepower, the price premium for new specialty motors is significantly higher than the price premium for rewinding a specialty motor. For example, on average, it will cost 5 to 15 percent more (depending on horsepower) to rewind a 3,600 rpm motor than to rewind an 1,800 rpm motor. A new 3,600 rpm motor will cost between 5 and 25 percent more than a new 1,800 rpm motor. The differences for

specialty motors are more striking. It costs 10 to 30 percent more to rewind a specialty motor. However, a new specialty motor is two to four times the cost of a new TEFC motor. These price premium multipliers are for general comparison only since actual prices will vary depending on local wage rates, dealer and repair discounts, and the specific repairs required.

First costs dominate the repair/replace decision for larger and specialty motors. The cost differences in absolute terms for individual motors over 50 hp are significant—at least \$2,000 and up to \$20,000 for specialty motors. We have summarized absolute cost differences by motor type and horsepower category (Figure 5). Utility rebates for motors over 100 hp, which range from \$6 to \$8 per horsepower, are unlikely to have significant impacts on the decision to repair or replace. Few utilities in the United States offer rebates for motors over 200 hp. Once the decision to replace is made, rebates can significantly influence the economics of the choice between replacing the motor with a premium-efficiency or a standard-efficiency model.

Figure 5  
Average Difference Between New Motor and Standard Rewind Cost For 1800 RPM  
Motors by Motor Type and Horsepower

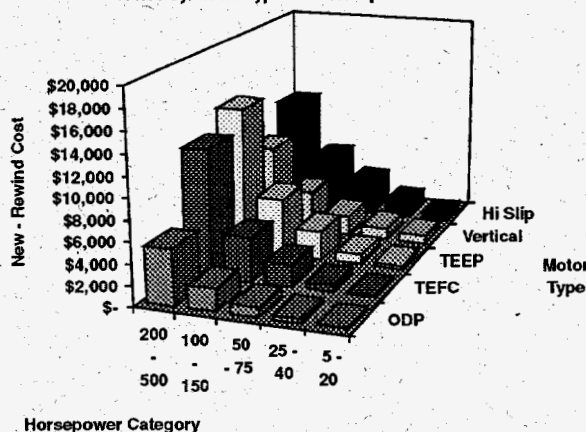

Final costs to include are additional installation costs that a motor change may entail. If the speed, horsepower, or frame (a newer T-Frame replaces an older U-frame, for example) changes as part of a motor replacement, changes in wiring, new mounts, belts, pulleys, or other installation modifications may also be required. These costs also should be factored into the decision to replace a motor.

## How will the Decision Affect Operating Costs?

Operating costs can be affected by any changes in energy use caused by repairing a motor or switching to a new motor. The sources of the difference in operating costs can be changes in efficiency level caused by repair or by changing to a new motor with a different efficiency level than the old motor (from standard to premium-efficiency, for example).

*Changes in Energy Use.* Differences in energy cost between repairing and replacing a motor can be estimated with the formula:

### Equation 1:

$$\text{Energy Cost Savings} = \text{Hours of operation} * \text{hp} * \text{Load} * .746 * (100/(\text{ERr} - \text{IL}) - 100/\text{ERn}) * \text{EC}$$

## Equation 2:

$$\text{Demand Cost Savings} = hp * \text{Load} * .746 * (100/(ERr - IL) - 100/ERn) * \text{MDC} * \text{NM}$$

Where:

Load	=	Average motor load
ERr	=	Original Pre-Failure Efficiency Rating for the rewound motor
IL	=	Reduction in efficiency (percent) that results from rewinding
ERn	=	Efficiency Rating of the New Motor
EC	=	Local energy charge (cents/kWh)
MDC	=	Monthly Demand Charge
NM	=	Number of months demand charge applied

$$\text{Incremental Energy Benefit} = \text{Energy Costs Savings} + \text{Demand Costs Savings}$$

Motor horsepower and efficiency data are normally found on the motor's nameplate. Discussions with motor laboratories concerning research in progress suggest that monitored values for motor efficiency deviate somewhat from nameplate ratings. However, nameplate ratings are a good guideline. Reliable data for the hours of operation and motor load inputs (which drive the energy use calculations) are often not readily available. While hours of operation can be measured fairly easily, there are currently no low-cost field approaches for measuring motor load.

Motor efficiency is generally not an important consideration for most specialty motors. It is difficult to easily estimate efficiency levels for these motors. Consequently, they are not covered in NEMA standards or regulated under the Energy Policy Act, and most manufacturers do not offer energy-efficient models for them.

Motor efficiency varies by load. Motors typically run at peak efficiency near 75 percent of full load. Efficiency declines slightly as a motor is moved towards full load (100 percent), but it drops off very sharply below 25 to 50 percent of rated load. (For a more detailed discussion of trade-offs between load, efficiency, hours of operation, and motor speed see McCoy et al., 1992.)

Assuming the application and motor type are not changed, the energy cost differences between the repair and replace options are based on changes in motor efficiency. These changes can originate in three areas:

- *Motor efficiency decreases after rewind.* Although case studies have shown that motors can be repaired and rewound with no decrease in efficiency if a shop follows quality repair practices (Ontario Hydro, 1992), most studies report current repair practices increase motor losses by about 8 percent after rewind. This decrease is equivalent to a decrease in efficiency rating of 1 percentage point for motors under 100 hp and about one half of 1 percent for larger motors (Schueler et al., 1994; Zeller, 1994).
- *Efficiency improvements in the overall motor stock over time.* It is conventional wisdom that the average motor manufactured in the 1960s and 1970s was less efficient than the average motor manufactured today, and that simply replacing an older motor with any new motor would, on the average, increase energy efficiency. However, this may not always be true. Historical data on the energy efficiency of available motor stock are not available for all motors. The limited data that are available suggest that efficiency levels of *standard* motors have remained unchanged over the last 20 years.

■ Data are available on the average efficiency of 1,800 rpm ODP motors for 1975 (USDOE, 1978). When compared to 1994 data, nameplate efficiency did increase for those motors under 10 hp and those between 50 hp and 100 hp (Figure 6). The average efficiency of brands between 10 and 50 hp decreased, however. Note that the 1994 data does not reflect the impact of the new national motor efficiency standards, the regulation aspects of which will not be completely in effect until 1997. Motor purchasers may not see any efficiency gains from immediately buying a new motor.

Figure 6  
Average Motor Stock Efficiency By Year  
1800 RPM ODP Motors

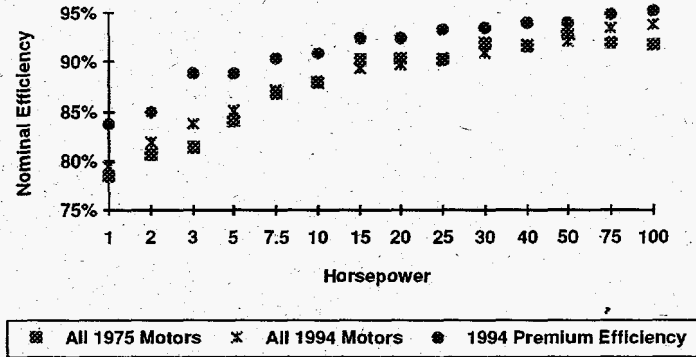

*Energy-Efficient Motors.* What has changed since the 1970s is the market penetration of energy-efficient motors, particularly for larger motors. Since 1987, sales of energy-efficient motors (those that exceed NEMA Table 12-9) has grown by 8 percent for motors of 1 to 5 hp, 11 percent for motors of 5 to 20 hp, 18 percent for motors of 21 to 50 hp, and 16 percent for motors of 50 to 200 hp. (NEMA 1994)

*The Decision to Rewind or Upgrade to an Energy-Efficient Motor.* The decision many utility customers face is whether to rewind a failed motor or to take advantage of a utility rebate program and replace it with an premium-efficiency motor. If the motor in question is at the end of its life and the application is amenable, rebates make upgrading to premium-efficiency motors an attractive option for motors of any horsepower. If the motor *can* be rewound, motor rebates are more likely to encourage customers to replace motors between 25 and 60 hp. In effect, rebates increase the break-even point for replacement versus repair by 10 to 20 hp (Figure 7).

Figure 7  
Repair vs Replace with Premium-Efficiency Motor: First Cost vs  
Two Years of Energy Savings -- Motors Under 75 hp  
1800 rpm TEFC Motor

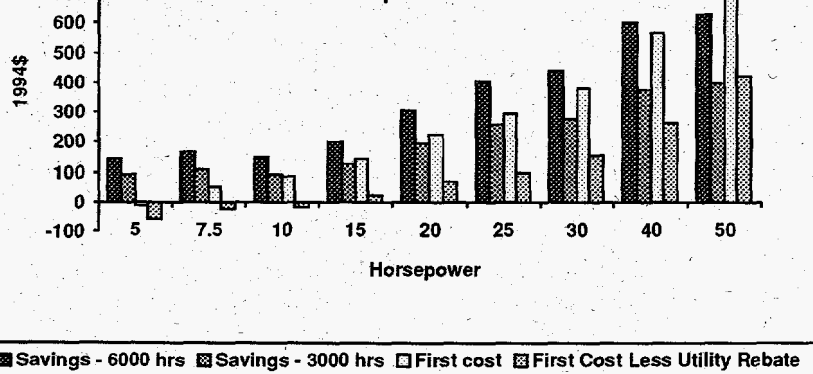

The potential impact of rebates on replacement of motors over 150 hp is limited, however. As is shown in Figure 8, energy benefits rise more slowly than the difference in first costs between a new motor and rewind. In the figure we compare two years of energy benefits that result from replacing a 1,800 rpm TEFC motor with a premium-efficiency model with the added cost of buying the new motor. The energy cost savings depend on the motor load, the hours of operation, and the energy and demand charges the user faces. We calculated the impact of rebates given both 3,000 and 6,000 hours of operation, a load factor of 0.75, and average national industrial rates (\$.05/kWh and \$9.00/kW). The use of two years of savings is a proxy for a two year payback.

**Figure 8**  
**Repair vs Replace with Premium Efficiency Motor: First Cost vs**  
**Two Years of Energy Savings – Motors 75 hp and over**  
**1800 RPM TEFC Motor**

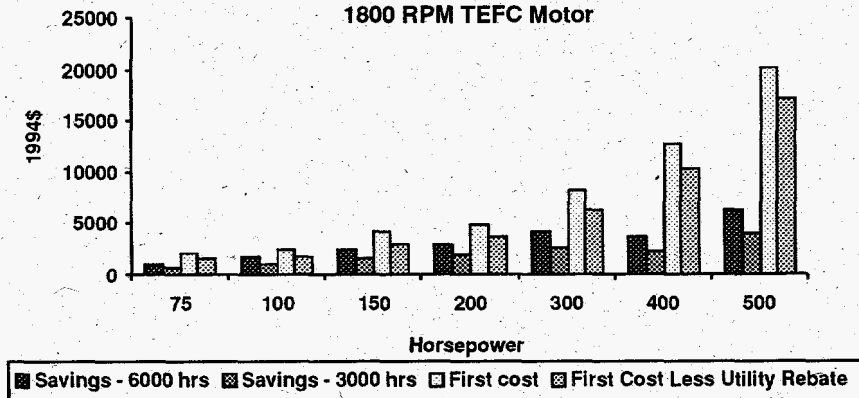

When energy savings and additional purchase costs alone are considered, motor users can realize a payback period of two years or less when they replace motors of up to 25 hp. When a typical utility rebate is included, the break even point increases to 50 hp. For motors over 75 hp, the motor user would save more by repairing or rewinding. With higher energy costs, more complex repairs, and longer hours of operation, the break-even point could increase to as high as 100 hp. Lower utility rates, reduced hours of operations, the absence of utility rebates, and special motor characteristics could drive the decision to replace down to those motors of 5 to 10 hp.

## What are the Differences in Reliability for a New Versus a Repaired Motor?

Which approach most reduces the likelihood of future motor failure? Claims conflict. There is little empirical data to make a case one way or the other. Repair shops claim they routinely upgrade insulation from Class A or B to Class F during rewind. This reduces the likelihood of premature thermal aging. However, if other elements of the repair are poor quality, the user will not see these benefits.

Motor salespersons argue that the overall quality of new motors is more consistent. But, there is a significant difference between the top and the bottom of the line. Standard efficient bottom-of-the-line motors generate more heat than energy-efficient motors and can fail earlier. Also, the cooling fans on energy-efficient motors have lower heating loads than standard-efficiency motors but are not down-sized proportionately. Energy-efficient motor fans often have more margin in them relative to the lower losses. Fans on energy-efficient motors can be designed smaller than fans on standard motors because they have less heat to dissipate. All of the potential for downsizing is not always used, which can result in some slight oversizing compared to design requirements. This extra margin can improve heat dissipation. Finally, manufacturers

often bundle energy-efficiency features in new energy-efficient motors with higher quality parts and features. These can also extend motor operating life.

Replacing a motor does not always improve reliability. Maintenance and engineering staff are often reluctant to replace an old motor that is working smoothly with a new motor that may break down. This resistance is well founded. Failure rates for any product, including motors, follow a bathtub curve (Figure 9) (Nailen, 1994). Breakdowns and other maintenance patterns are typically high immediately after installation. Problems decline after the motor is broken in and eventually increase again with burn-out and old age. If a motor is removed from service prematurely while it is in the middle of the bathtub cycle, maintenance problems and associated downtime and repair cost could actually increase. The worst possible situation is to cycle through motors so quickly that maintenance staff are constantly breaking motors in.

Figure 9  
The Repair Cycle

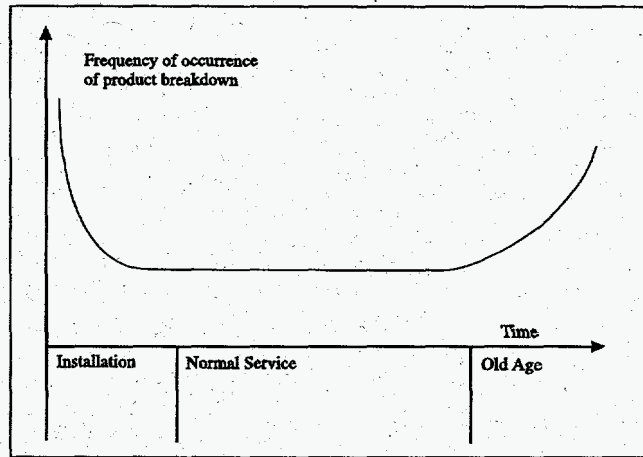

Either a quality rewind or an energy-efficient new motor may extend motor operating life. The jury is out as to which is better. Although no empirical studies have been completed to verify this, it is likely that either a quality rewind or a properly specified energy-efficient new motor has a longer operating life than a poor quality rewind or a standard efficient motor.

## What are the Simple Payback Criteria or Rate of Return?

Incremental cost information and energy savings estimates must be analyzed taking into account the specific motor user's financial criteria or hurdle rates. Ideally, annual cost and benefit streams are discounted using net present value methods. Simple payback analysis offers a useful shortcut. In simplified form, the payback formula for analyzing a rewind/energy-efficient motor replacement is:

$$\text{Equation 3: } PB = \frac{NC + IC - RWC - UR}{ECS + DCS}$$

where

- PB = Simple payback
  - NC = New motor cost
  - IC = Incremental installation costs (if any)
  - RWC = Rewind/Repair Cost
  - UR = Utility Rebate (if available)
  - ECS = Energy Charge Reduction (Equation 1)
  - DCS = Demand Charge Reduction (Equation 2)
- Downtime and reliability may be considered qualitatively.

### Example

A 50 hp 1,800 rpm TEFC motor has failed at ACE manufacturing. A spare motor is available so downtime is not a consideration. The motor runs 12 to 15 hours a day (5,000 hrs/yr) and does not appear to be significantly under or over loaded. Since the local utility offers a rebate for premium-efficiency motors, ACE gets a bid on a premium efficient model with a 3/4 load efficiency of 95 percent. The purchase price including a 25 percent dealer discount is \$2,550. The utility rebate is \$8/hp or \$400. Local utility rates are \$.05/kWh for energy and \$9.00/kW for demand.

The original efficiency of the failed motor, still legible on the nameplate, is 91 percent. After inspecting the failed motor the repair shop finds bearings need to be replaced. The bid on the repair comes in at \$1,100. ACE is not familiar with the quality control of the shop. They assume an 8% increase in losses, which is a 0.72% efficiency decrease.

$$\begin{aligned}\text{Energy Savings} &= 5000 \text{ hrs} \times 50 \text{ hp} \times .75 \text{ (load)} \times .746 \times \\ &\quad (100/(91 - .72) - 100/95) \times \$0.05/\text{kWh} \\ &= \$384.89\end{aligned}$$

$$\begin{aligned}\text{Demand Savings} &= 50 \text{ hp} \times .75 \text{ (load)} \times .746 \times \\ &\quad (100/(91 - .72) - 100/95) \times \$9.00/\text{kWh} \times 12 \text{ (months)} \\ &= \$166.27\end{aligned}$$

$$\begin{aligned}\text{Payback} &= \frac{\$2,550 - \$1,100 - \$400}{\$384.89 + 166.27} \\ &= 1.9 \text{ Years}\end{aligned}$$

The energy savings from replacing the failed motor with a premium efficiency motor will pay back the costs of the new motor in 1.9 years. The net present value, assuming a 20 percent discount rate and five years of energy savings is \$928.

The "new versus rewind" compare option in MotorMaster<sup>®</sup> conveniently calculates simple payback. The program also provides energy cost savings formulas, new and rewind motor efficiency levels, and default values for rewind costs. It accepts more precise information from either actual bids or pricing estimates from pricing guides like Vaughen's. MotorMaster<sup>®</sup> currently does not allow ancillary and downtime costs to be factored into the comparison.

## Special Issues for Repairing Energy-Efficient Motors

The increasing market penetration of energy-efficient motors has raised some special issues. Further gains in efficiency above currently available, premium-efficiency motors are at or near the point of diminishing returns if there is no fundamental change in the technology. As the penetration of energy-efficient motors increases and currently used, standard-efficiency motors fail, energy-efficient motors will show up on the shop floor. In 1994, only 5 to 10 percent of repaired motors were energy efficient. One consequence of the increase in the number of energy-efficient motors may be that the energy savings incentive for replacing rather than rewinding motors will decrease, and rewinding may regain market share. Potential increases in rewind motors raises two questions:

- *Can Energy Efficiency in Rewound Energy-Efficient Motors Be Maintained?* It can. In 1991, Ontario Hydro conducted a case study in which nine energy-efficient

motors were rewound by commercial rewind shops (Ontario Hydro 1992). BC Hydro conducted a second case study in 1992 where 10 energy efficient motors were rewound (Zeller 1992). Both studies found that when proper procedures were used, efficiency was maintained. Rewinds of energy-efficient motors can be slightly more challenging. They may require closer air gap tolerance and tighter slot fill. Some repair shops believe repairing energy-efficient motors is *much* more complex. However, many of the "special" problems reported for repairing energy-efficient motors, such as controlling for core loss and closer tolerances, are in fact shared with all new motors.

- *Does it Cost More to Rewind Energy-Efficient Motors?* Repairing a premium-efficiency motor may be 10 percent more costly than repairing a standard-efficiency motor because of the difficulty of tracking down non-standard parts, additional testing, and working with closer tolerance and tighter slot fill during rewinding. However, some of these costs, such as additional testing should be incurred in the quality repair of any motor, standard or premium efficiency.

## Putting It All Together

Local utility rates and the number of hours a motor operates are critical to determining whether to repair or replace it. To illustrate this, Figure 10 summarizes the costs and benefits of a rewind versus an energy-efficient replacement for a standard 1,800 rpm TEFC motor over eight combinations of rates and motor operating hours. The lines represent the number of years it takes to pay back incremental costs with annual energy cost saving given the selected operating hours and utility rates. To use this figure, find the rate and motor operation scenario closest to yours. Select the motor users payback criteria and move down to horsepower. Motors at or below that horsepower could be replaced rather than rewound and meet the payback criteria.

The 3,000 hour/high rates case is almost identical to the 8,000 hour/average rate case so it was not graphed.

Payback estimates may be inflated by the simplifying assumptions used. We made the following assumptions:

- Bearing replacement and other repairs were not included in rewind costs, so they are generally underestimated.
- Utility rebates were excluded since they are less commonly available.
- Assumed efficiency for the failure motor was the average 1994 efficiency of motors not exceeding NEMA standard 12-9.
- The efficiency of the replacement motor is the average for motors exceeding NEMA 12-9.
- If specialty motors were analyzed, simple payback curves would be significantly higher and steeper.
- Motor load was held constant at 75 percent.

Given these assumptions, we can draw some important conclusions:

- Motor replacement doesn't pay its cost back in two years when a motor is operated under 3,000 hours a year (one shift).



- In areas with low rates, such as the Northwest, rewinding may be the more attractive option for motors over 15 hp. In high rate areas, the balance point may be as high as 150 hp.
- With the possible exception of high utility rate areas, replacing a rewindable motor is not economically attractive over 100 hp.

**Figure 10**  
**Payback Analysis: Energy Efficient Motor Replacement (NEMA 12 -9) Vs A**  
**Basic Motor Rewind: 1800 RPM Standard Efficiency TEFC Motor**  
**For Selected Operating Hours and Utility Rates**

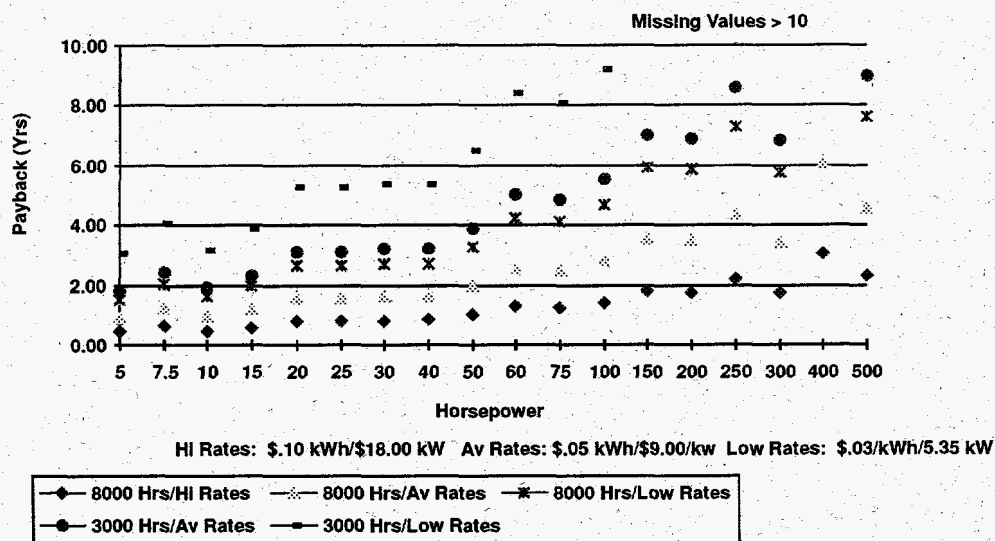

## Rules of Thumb

In some cases, a detailed analysis including motor repair bids and new motor price quotes may be needed to determine which course of action is in the best economic interest of the customer. However, in many motor applications, the benefits of pursuing either the repair or the replace option are so pronounced that a detailed analysis is not needed. Here are some rules of thumb to guide the decision.

- Evaluate whether either option—replacing or repairing—will add to downtime for critical equipment.
- Most specialty motors should be rewound. They are considerably more costly to purchase new and are less likely to be in stock.
- It is almost always more economical to replace non-specialty motors under 10 hp. Repair costs are equal to or higher than new motor costs, and these motors are very likely to be in stock.
- It is almost always more economical to rewind motors over 100 hp. New motor costs rise steeply after 100 hp, and energy-efficient replacements may not be in stock. For heavily used motors in areas with high utility rates, it may be necessary to analyze the benefits of replacing non-specialty motors of up to 150 hp.

The following flow chart is provided as a guide for the decision process. Appendix C takes the stages in this decision process and elaborates on each.

### **Steps for Deciding to Repair or Replace a Failed Motor**

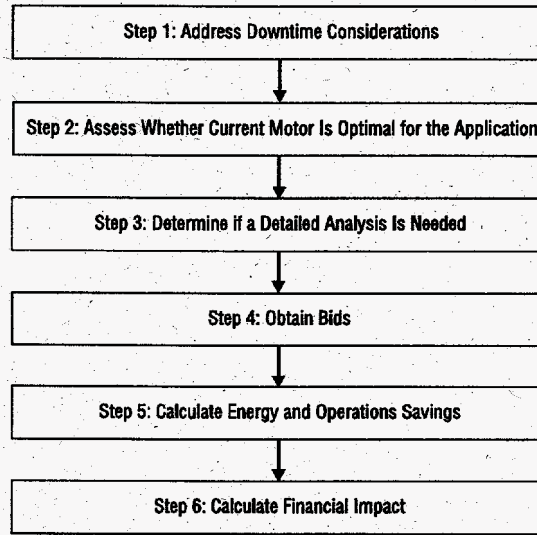

## Section 4

---

# Barriers to Quality Motor Repair and Rewind

Quality motor repair is a cumulative process that requires getting many small details right. These details include, but are not limited to:

- Using the correct replacement bearings.
- Proper greasing.
- Avoiding mechanical modifications to bearings, bearing fits and seals during disassembly or reassembly.
- Avoiding overheating the core during winding removal.
- Protecting core laminations during repair to prevent shorts that result from sand blasting, mishandling, or assembly pressure.
- Maintaining the circular mils and number of turns in the windings.
- Maintaining properly designed winding patterns.
- Replacing loose or cracked conductor bars with similar parts.
- Detecting and repairing damage to end shields and bent motor shafts.
- Maintaining the air-gap symmetry between stator and rotor.

Many of the things that can go wrong during repair to decrease reliability and motor energy efficiency are subtle, and they require testing to diagnose properly. A detailed discussion of motor testing during repair can be found in the companion report to this guidebook *Electric Motor Repair Industry Assessment: Current Practice and Opportunities for Improving Customer Productivity and Energy Efficiency* (Schueler, Leistner and Douglass, 1994).

What are the barriers to getting these details right? Why are quality repair practices not as broadly implemented as they could be? Critical educational, financial, infrastructure, and technical barriers need to be eliminated. The most critical are highlighted below.

## Educational Barriers

*Motor repair customers do not recognize quality motor repair and seldom ask for it. Customers seldom provide shops with repair specifications, much less specifications for quality repair or for maintaining energy efficiency. Customers need tools to identify:*

- The elements of a quality repair.
- The challenges faced by repair shops and what shops need from the customer to provide the best repair.
- The value of paying for higher levels of service and efficiency.

- How to get higher levels of service from shops, particularly how to get motors re-wound, without reducing the motors' efficiency.

*Many repair shops do not know how to maintain energy efficiency during repair.*

Many shops do not appreciate or understand the value of maintaining energy efficiency. Some important misunderstandings include:

- Energy-efficient repair practice is only important in repairing premium-efficiency motors.
- Premium-efficiency motors are significantly more costly and more technically difficult to repair than standard-efficiency motors.
- Core losses from burn-out practices are the only important source of decreased efficiency, and controlling burn-out is the only important loss prevention strategy.

A significant number of repair shops, especially smaller ones, are not aware of repair practices that may reduce repair quality. Problem practices include changing winding configurations without adequate redesign, removing windings with high burn-out temperatures, and inadequate testing practices.

## **Financial Barriers**

*Quality repair can take more time.* Motor repair shops are often under tremendous pressure to get motors repaired and back on line, particularly if the repaired motor is critical to the customer's operations. Conducting thorough motor diagnostics before and after repair, finding matching parts and wire, and re-engineering winding configurations precisely may take time that the shop may not have been given by the customer. Motor repair shops must balance the customer's need to have motors repaired as quickly as possible with the time requirements needed to do the job right.

*Quality repair costs more.* Quality motor repair practices can be expected to increase repair costs by up to 10 percent. Sources of increased costs include additional equipment and labor for testing and for controlling burn-out, and increased inventory costs for maintaining adequate stocks of parts and wire. Quality assurance programs may also have significant start-up costs for certification and registration. For example, ISO 9000 registration and follow-up certification may cost several thousand dollars per site. There are also significant investments required for measurement, benchmarking, and internal information sharing that are an essential part of total quality management approaches.

*Working with small shops in an industry in transition.* Anyone making an effort to work with the motor repair industry must acknowledge that the industry is under pressure from declining profit margins, increasing labor costs, and the declining manufacturing base in the economy. Shops will resist efforts that rely on more government regulation and mandates. Additional mandates could weaken the industry.

Numerically, the industry is dominated by small shops that have low repair volumes, work on smaller horse power motors, and have small staffs. These shops are the least likely to have the right equipment or training for quality repair and are the least able to afford it. Requirements for more equipment and testing, and for maintaining larger stocks of spare parts could have the indirect impact of driving smaller shops out of the repair business. Large investments to improve equipment and operating practices in small shops may not be justified because of small business volumes.

## **Infrastructure Barriers**

*Manufacturers' motor specifications are often unavailable or inaccessible.* Shops reported that winding data were not readily available for 30 to 40 percent of the motors they repaired. Specifications for bearings, fans, and lubricants are not accessible in a timely fashion from all manufacturers. These specifications are critical for returning the motor to its original condition. In some cases, this information can be reverse-engineered, but this practice is time-consuming and can be inexact.

Data availability varies considerably by manufacturer. Manufacturers do not have a strong incentive to provide these data and make motors more repairable. Some consider the data to be proprietary and are reluctant to release it. Others consider the data to be a salable commodity and charge for it. Although motor end-users expect larger motors to be repairable, new motor customers do not stress ease of reparability when purchasing motors. Further complicating this situation is the absence of a system to provide repair specifications to shops in a timely manner.

*Parts and wire sizes are not available locally.* Small and mid-size shops reported difficulties keeping complete stocks of wire sizes and bearing types on hand. Costs for keeping large inventories of seldom-used wire sizes and bearings can be prohibitive. Shops will use substitutes if the correct sizes or types are not available.

*Tools and equipment for winding and winding redesign are not available.* Even with good winding data and the right wire in stock, shops change winding patterns without proper redesign. Not all shops are aware of the potential reliability and efficiency impacts of changing winding configurations. Small and medium-sized shops often do not have the equipment to test the impacts of alternate winding paths, nor the tools to properly redesign winding if the pattern is changed. In a recent survey, 15 percent of shops, mostly small volume operations, noted they changed winding configurations because of equipment limitations.

## **Technical Barriers**

*Winding removal strategies that do not damage motor cores are needed.* Most windings are removed by burning them out in ovens. Motors that have been rewound previously pose even more challenges because of the numerous dips, bakes, and epoxies used. Almost 40 percent of the shops surveyed burned out cores at temperatures of 750 F or more, which can cause core damage. Forty percent of the shops did not have water suppression systems, most temperature controls were not frequently calibrated, and few shops placed temperature sensors in the motor cores. However, this problem may be less severe for new motors with cores made with C-5 steel which is less subject to overheating problems.

*Lack Of Standardized Designs.* Shops reported that one of the biggest barriers to returning motors to their original condition was finding parts and wire for motors using non-standard components. The diverse number of wire sizes, bearing types, and other motor components that a motor repair shop must work with is very challenging. There has been some movement towards more standardized motor designs in the European motor market in response to this problem.

*Comprehensive data on the magnitude and sources of increased losses after motor repair and the costs and effectiveness of remedies is needed.* Little comprehensive research has been done to associate the magnitude of efficiency decreases with specific motor repair practices and to understand how these practices interact. Existing studies

have very small sample sizes and are restricted to small horsepower motors. Key questions that need further investigation include:

- Are the efficiency decreases for large motors of the same magnitude as those for smaller motors? Are the problem practices as common in the repair of larger motors?
- What are the efficiency and performance implications of specific problem repair practices?
- How effective are alternative strategies for reducing core loss during burn-out (oven calibration, water suppression systems, and alternative burn-out regimes) and for diagnosing core losses?
- How much do specific repair practices that maintain efficiency contribute to motor reliability and performance? For example, does using smaller wire size significantly impact repair life?
- What are the incremental costs for specific repair practices that maintain efficiency?

## Section 5

# Strategies for Encouraging Quality Motor Repair

Working with repair shops and motor customers to support quality motor repair presents a competitive opportunity for utilities. Utilities can provide key commercial and industrial customers with valuable information and services to help manage energy use and improve productivity. By encouraging and supporting quality assurance and quality repair, efficiency losses related to motor repair can be reduced, and the reliability of repaired and rewound motors can be improved to deliver energy savings and support a strong motor repair industry. This section identifies strategies for encouraging quality repair and developing the utility partnerships that will be crucial for carrying them out.

## The Overall Strategy: Market Transformation

Past attempts to encourage energy-efficient technology and practice through utility demand-side management (DSM) programs have focused on retail approaches—payments of incentives and rebates to individual customers. The growing pressure on utilities to keep near-term rates low in the face of increasing deregulation and competition means that utilities are less willing or able to invest in these efforts. Utilities must plan investments strategically. In response to the pressure to keep rates low and based on lessons learned from a decade of DSM program evaluation, the DSM paradigm is shifting towards market transformation models. Market transformation is not merely a new name for old programs. Market transformation efforts accelerate the adoption of new technologies and practice by providing education and labeling, supporting codes and standards, and targeting incentives at the wholesale and industry association levels. See Feldman (1994) and Nadel and Geller (1994) for a more detailed discussion of market transformation approaches.

Transforming the motor repair market to accelerate the adoption of quality motor repair practices will require a national effort involving industry, government, and utilities. Utilities can leverage their resources by coordinating strategies through intergovernmental and interutility associations such as the Consortium for Energy Efficiency (CEE). In this section we describe what utilities can do to support market transformation nationally and in their local service territories. Roles for industry and government are discussed in depth in the companion report to this guidebook *Electric Motor Repair Industry Assessment: Current Practice and Opportunities for Improving Customer Productivity and Energy Efficiency* (Schueler, Leistner and Douglass., 1994).

## Working with the Motor Repair Industry

Most shops in the motor repair industry have a strong desire to provide timely and quality motor repair services, and they are willing to work with customers and utilities to that end. This is an important point of leverage. Utilities can help the motor repair industry achieve that goal by encouraging them in five major areas:

*Support Quality Assurance Programs.* Utilities can help link energy efficiency and quality repair to quality assurance efforts by:

### Benefits to Utilities that Support Quality Motor Service Programs

- Provide valuable service to key industrial and commercial customers.
- Meet regulatory mandated demand-side management (DSM) targets while serving key clients.
- Improve transmission and distribution efficiency—poor repair practices can increase the peak power demand of a repaired motor.

- Collaborating with local shops to establish a voluntary, industry-led repair shop certification program through which shops could earn certification by going through training, having key testing equipment on site, and implementing existing quality assurance standards (ISO 9000 or EASA-Q or equivalent).
- Supporting and promoting an easy-to-recognize certification label.
- Supporting quality assurance efforts by recognizing shops with outstanding quality assurance programs.
- Providing grants or financing to key shops to reduce initial cost for ISO and EASA-Q certification and recertification.
- Establishing a mentoring and training relationship with key shops if your utility has its own well-established and effective quality assurance program.

*Help Improve Education and Training for Motor Repair Shop on Quality Repair Practice.* Shop-floor knowledge of quality motor repair practice must be strengthened. To improve education and training, utilities can take the following steps:

- Encourage development and distribution of shop-floor oriented quality motor repair guidebooks, training materials, and specifications.
- Support joint training programs with motor repair industry trade associations to stress the importance of maintaining efficiency during repair for all motors. Key training needs are described in the *Motor Repair Industry Assessment*.

*Reduce the Initial Cost for Capital Intensive Testing and Repair Equipment.* Many shops do not have the capital reserves to upgrade burn-out ovens with water suppression systems, to purchase more advanced testing equipment, or to make other capital investments that are helpful in maintaining efficiency. A core-loss tester alone can cost between \$15,000 and \$30,000. Manitoba Hydro ran a very effective program in which they offered to co-fund 50 percent of the cost of a core-loss tester up to a maximum of \$10,000 (Canadian \$) in exchange for commitment from the shops to participate in development of a Quality Motor Service Program.

As an alternative, utilities might consider forming a consortium with EASA and deal directly with core-loss testing equipment manufacturers to improve the quality and bring down the price. The infrastructure for pursuing this type of market transformation venture is already in place through the Motors Subcommittee of the Consortium for Energy Efficiency.

*Support Quality Motor Repair Research.* More research is needed to identify the magnitude and sources of decreased efficiency after motor repair and to assess the costs and effectiveness of alternative strategies for improving quality repair. Join one of the utility consortia that are investigating these issues. There are two:

- EPRI and BPA have collaborated to fund this guidebook and the U.S. Motor Repair Industry Assessment. Future activities include developing and testing model quality repair specifications, researching the effectiveness of quality repair practices, and developing a software package to more easily disseminate motor specification information to shops (RewindMaster). You may contact the Motor Challenge Information Clearinghouse to obtain current information on availability of this publication.
- Nine Canadian utilities have also formed a consortium to pursue joint education and research efforts. Canadian utilities involved in the Coordinated Utilities Approach include: Hydro Quebec, Ontario Hydro, British Columbia Hydro, Manitoba Hydro, Alberta Power, Trans Alta, Nova Scotia Power, and New Brunswick power. The



utilities' current projects include a detailed analysis of core losses, a technical manual to complement existing quality standards, and a motor acceptance test that customers may use on new and repaired motors. You may contact the Motor Challenge Information Clearinghouse to obtain current information on availability of this publication.

*Join with Industry Associations.* As stated earlier, about two-thirds of the motor repair business in the United States is done in EASA affiliated shops, and slightly under half the motor repair shops in the United States are members. EASA has been very active and interested in improving the quality of motor repair. This association offers extensive training resources and certifies shops to the *EASA-Q: Quality Management System for Motor Repair*. To access these extensive training materials, utilities can become allied members. (See Section 2 for contact information.) EASA has over 30 local chapters, which provide utilities with an excellent avenue for reaching motor repair shops and co-sponsoring training. Virginia Power and North Carolina Power have collaborated successfully with EASA.

There are independent repair shops that have a strong interest in quality repair but that are not EASA members. Some effort may be needed to identify larger shops which are not EASA members, for example by comparing the membership lists available from EASA with the motor repair listings in the yellow pages.

## Working with Motor Repair Customers

Utilities' greatest value to motor repair customers is in educating motor users about the benefits of quality motor repair and helping them learn to identify quality repair shops. Helping motor users understand the positive relationship between quality repair and motor reliability will encourage them to learn more. Utilities can also encourage users' awareness of repair issues in the following ways:

- Provide fact sheets to customers on how to identify quality repair shops and the elements of good repair. Collaborative point-of-sale displays stressing the value of paying extra for quality repair would be useful. This is a less intensive approach than VP's program. The appendices of this document are designed to be used as fact sheets to assist in your education efforts.
- Provide access to independent motor testing and assessments to help users understand the repair versus replace option.
- Support national or local efforts to develop an easily recognizable quality certification label for repair shops.

## Working with Manufacturers

Motor manufacturers also have a role in improving the quality of motor repair. Utilities can work directly with both motor repair associations and manufacturers to:

- Encourage them to provide better and more timely information to repair shops on original motor design and test specifications.
- Improve the information provided in nameplate data.
- Encourage them to stock replacements for custom bearings and to make them available quickly and without excessive mark-up.

## Virginia Power/North Carolina Power's Motor Rewind Customer Education Program

Virginia Power (VP) and North Carolina Power jointly considered an early effort to develop and certify motor repair facilities on their own. Instead they chose to work with EASA. The reason for this decision was that EASA already has motor repair standards and is aggressively pursuing ISO 9000/EASA-Q certification for its members. VP also felt EASA has superior knowledge and experience with the repair of electric motors. The utility determined that a certification program run by EASA would be more cost-effective, credible, and less controversial.

VP's first step was to become an Associate Member of EASA. Presently, there are two other electric utilities with this status. EASA membership provided access to literature, standards, and conferences. VP promotes EASA standards at every opportunity, such as energy audits and customer meetings. In 1994, VP conducted motor seminars for over 300 commercial and industrial customers and distributed EASA standards and information to them.

VP's strategy is to educate the customer to base their decision whether to repair or replace existing motors on economics and individual motor circumstance. An important part of the recommended motor replacement/repair policy includes selecting a quality motor repair facility that meets EASA standards. VP does not recommend that motor users choose or avoid specific repair shops; however, several customers have changed shops based on EASA literature and standards.

VP also offers commercial and industrial customers access to free motor testing (a value of up to \$1,000 per motor) through the Industrial Electrotechnology Laboratory (IEL) in Raleigh, North Carolina. IEL members include most of the major utilities in Virginia, South Carolina, and North Carolina. According to the program coordinator, the ability of rewind customers to have complete and independent laboratory data on the condition and efficiency of their motors places additional pressure on rewind shops to do a quality job.

- Encourage more standardization in motor parts and design.

## Matching Investments to Utility Benefits

*Energy Savings From Individual Motors Are Small.* Significant gains in energy efficiency are possible if quality motor repair practices are more widely adopted. However, these gains are made in very small increments, one motor at a time. For a 25 hp motor that operates one shift a day (3,000 hours/year), eliminating a 1 percent decrease in efficiency from rewinding saves only \$50. Assuming a 10 percent premium for quality repair, this yields a simple payback of three years. Although this is a reasonable investment, it is unlikely that the magnitude of the energy savings alone will generate much demand from motor users for quality repair.

Energy savings alone are also not adequate to support large price premiums for quality repair of small motors. To illustrate this point, we have plotted estimated savings from a 1 percent decrease in efficiency for a motor operating 50 percent of the time against estimates of national billing rates. Average national billing rates for electrical repair labor are approximately \$40 hour (Vaughen's, 1994). Machine time (for core-loss testing, etc.) is typically billed at \$45/hr. *The Industry Assessment* suggests that incremental costs for maintaining efficiency are on the order of an hour or two per motor (Schueler, Leistner, and Douglass, 1994). Increased labor costs for quality repair are dominated by fixed costs and increase very slowly with horsepower. Three levels of increased cost are plotted in Figure 11. At the lowest cost level and with average utility rates, the break-even point for quality repair based on energy savings is 25 hp. If quality repair takes three additional man-hours and the utility rates are low, the break-even point can be as high as 125 hp.

Figure 11  
Annual Energy Savings of 1 Percent Avoided Efficiency Decrease  
By Horsepower  
Versus Increased Repair Cost  
(4380 Operating Hours/Yr)

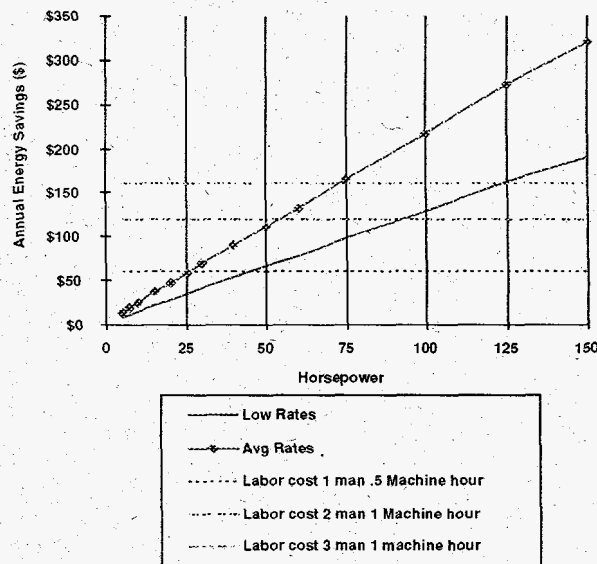

Even though energy savings alone are unlikely to increase motor users' demand for quality repair, energy savings are not the only benefit of good repair. Quality motor repair improves motor reliability, reduces the risk of premature failure, and reduces forced downtime—costs that are significant to motor users. Working with customers to help them use electricity-consuming equipment more effectively and productively can generate good will with key industrial and commercial customers. This good will and a

greater appreciation of the utility's added value is a key asset as large customers consider alternative sources of electric supply.

Retail approaches to improving quality of repair, such as rebates, are cost-prohibitive because they yield only small annual savings increments for individual motors under 100 hp. They will not be large enough to attract the attention of industry or to support administrative requirements. Therefore, we have recommended pursuing market transformation strategies that target the industry as a whole.

*Working with Large and Small Shops.* Small shops that have low repair volumes, work on smaller horsepower motors, and have small staffs dominate the repair industry. These shops are the least likely to have the best equipment or training because they are least able to afford it.

The small potential for energy savings may not justify significant direct utility involvement with small shops. It is not cost effective to subsidize the purchase of a \$15,000 to \$30,000 core-loss tester, other test equipment, or sophisticated burn-out equipment in the typical small shop. The *Motor Repair Industry Assessment* notes that small shops repair around 500 motors per year, most under 40 hp. Given average energy rates of \$.05/kWh and \$9.00/kW, the energy savings that such an investment would yield would be just \$50,000 per year. Besides the small return on investments for small shops, requirements that they have more testing equipment or larger parts and wire inventories could contribute to driving them out of business.

This does not mean small shops should be excluded from quality repair efforts. Instead, low-cost strategies for improving motor repair practice, such as tip sheets, are needed to complement larger efforts. Where possible, provide lower cost options to more expensive practices.

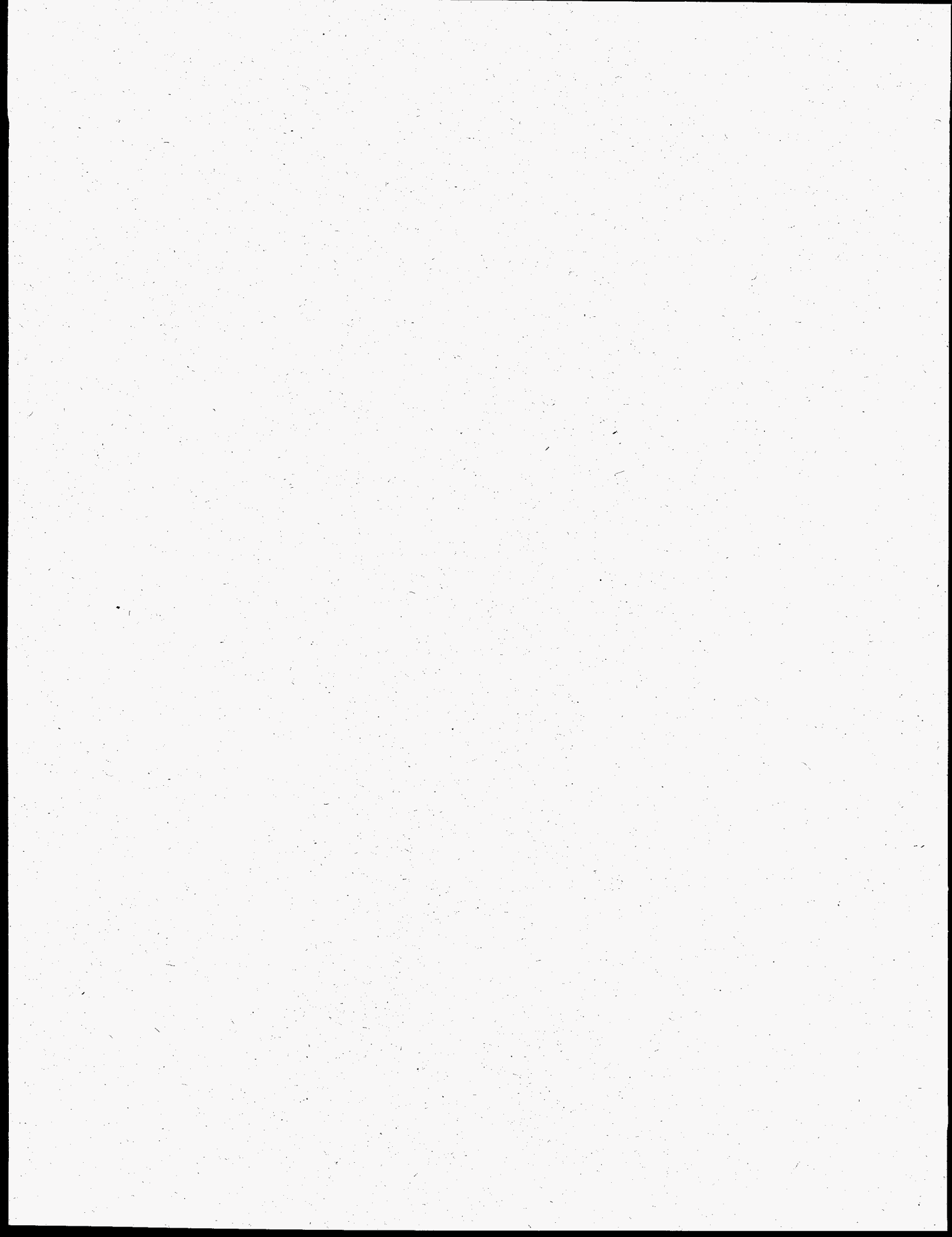

## References

- Brutlag and Associates. *1993 Member Needs Assessment: Final Report*. Electrical Apparatus Service Association, Inc., St. Louis, Missouri.
- EASA 1992. *EASA Standards for the Repair of Electrical Apparatus*. Electrical Apparatus Service Association, Inc., St. Louis, Missouri, February.
- EASA 1993. *EASA-Q: Quality Management System for Motor Repair*. Electrical Apparatus Service Association, Inc., St. Louis, Missouri.
- EPRI 1992. *Electric Motors: Markets, Trends, and Applications*. Electric Power Research Institute, Palo Alto, California, June. EPRI TR-100423.
- EPRI/BPA/DOE 1993. *Electric Motor Systems Sourcebook*. Electric Power Research Institute, RP 3087-21.
- Fryer, Lynn R., and Corey Stone. "Establishing Baseline Practices in the Industrial and Commercial Motor Market: Findings from the New England Motor Baseline Study." Proceedings: 6th National Demand-Side Management Conference, Electric Power Research Institute, Palo Alto, California, March 1993. TR- 102021. pp. 139-147.
- ISO 1987. *ISO 9000: Quality Management and Quality Assurance Standards: Guidelines for Selection and Use*. 1st ed. International Organization for Standardization, Geneva, Switzerland.
- McCoy, Gilbert A., Todd Litman, and Johnny G. Douglass. *1992 Energy-Efficient Electric Motor Selection Handbook*. Washington State Energy Office, Olympia, Washington. February 1992.
- Mehta, Vino. "Future for the Motor Rewind Industry: A Survival Strategy—Part One." *EASA Currents* 28, No. 2, February 1994. pp. 4-6.
- Nailen, Richard. "How Long Should a Motor Last?" *Electrical Apparatus*, Vol. 7, No. 5, May 1994. pp 29-35.
- Nailen, Richard L. "Fairyland Revisited: More Myths About Energy Efficient Motors." *Electrical Apparatus*. Vol. 46, No. 5, May 1993. pp. 26-31.
- Nailen, Richard L. *Managing Motors: The Complete Book of Electric Motor Application and Maintenance*. Barks Publications, Inc., Chicago, Illinois. 1991.
- Ontario Hydro. *The Effect of Repeated Rewinding on the Performance of Electric Motors*. Ontario Hydro, Energy Management and Corporate Relations Branch, Technical Services and Development, Toronto, Ontario, June 15, 1992. TSDD-92-035.
- Schueler, Vince, Paul Leistner and Johnny Douglass. *Electric Motor Repair Industry Assessment: Current Practice and Opportunities for Improving Productivity and Energy Efficiency—Phase I Report*. Washington State Energy Office, Olympia, Washington, September 1994.

- EASA 1992. "Tech Note No. 16: Guidelines for Maintaining Motor Efficiency During Rebuilding." Electrical Apparatus Service Association, Inc., St. Louis, Missouri, May.
- U.S. Department of Energy. "Classification and Evaluation of Electric Motors and Pumps." Assistant Secretary for Conservation and Solar Energy, Office of Industrial Programs, February 1980. DOE/CS-0147.
- U.S. Department of Energy. "Energy Efficiency and Electric Motors." U.S. Department of Energy, April 1978. HCP/M50217-01.
- Vaughen's 1994. *Vaughen's Complete Pricing Guide for Motor Repair and New Motors*. Price Publishing Company, Pittsburgh, Pennsylvania.
- Zeller, Markus. *Rewound High-Efficiency Motor Performance*. BC Hydro in association with Powertec Labs, Vancouver, British Columbia, August, 1992.
- Zeller, Markus. Phone Conversation. Demand-Side Consultants, Vancouver, British Columbia, April, 1994.

# **Appendix A:**

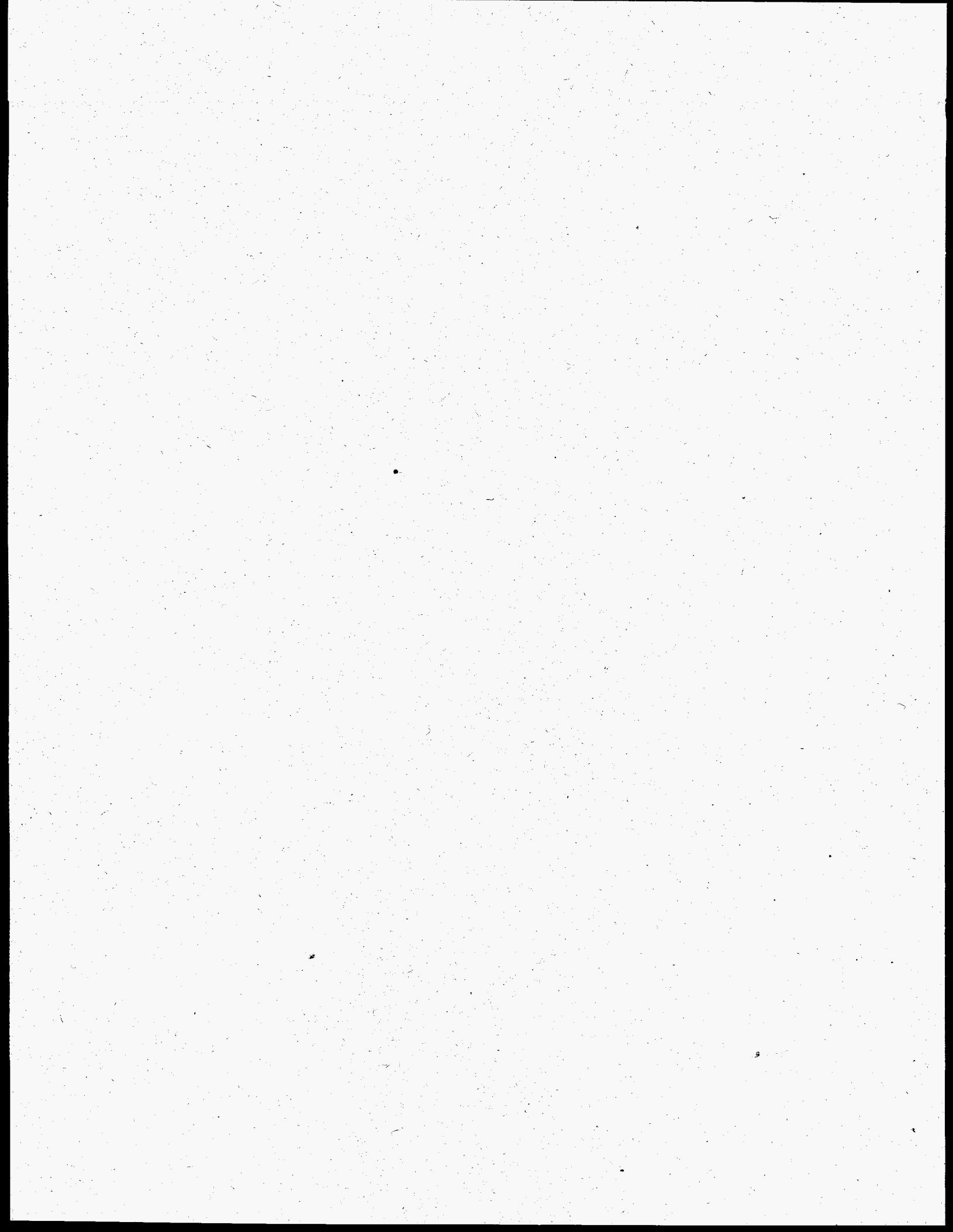



# Motor Basics

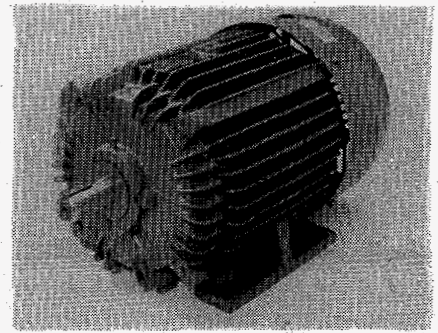

**T**here are many types of motors, but certain things are common among all. Nearly all motors have two major parts: a rotor and a stator. Each of these parts has an iron structure that creates, sustains, or responds to a magnetic field. The rotor is the rotating magnetic structure including the shaft on which it is mounted. The stator is the stationary magnetic structure that surrounds the rotor. Either or both rotor and shaft are wound with wire to provide a varying or moving electromagnetic force.

*Most motors that are large enough to be repaired when they fail fall into one of three major categories: three-phase induction motors, three-phase synchronous motors, or DC motors.*

## Characteristics of Motors

Induction motors are the most commonly used motors, often called the workhorse of industry. They are not always the most frequent visitor to repair shops because they are reliable and they are relatively inexpensive to replace when they do fail. Rotors of induction motors have neither permanent magnets nor connections to an electric power source. The varying stator field induces electrical current in a rotor structure known as the squirrel cage (called this because of its resemblance to the rotating exercise wheels often provided for pet rodents). This induced current creates complementary magnetic forces in the rotor. Induction motors are asynchronous, running at a speed slightly slower than the rotating speed of the magnetic field provided by the stator.

Synchronous motors are most common in applications where the ratio of horsepower to RPM exceeds one (i.e., applications requiring over 5,200 lb-ft. torque.) Synchronous motors typically have fixed polarity electromagnets on the rotor. They require special starting provisions. Some have an induction squirrel cage in addition to rotor windings so they can accelerate to near synchronous speed. Others rely upon a variable frequency drive. Synchronous motors turn at an exact speed, determined by line frequency, and they are usually more efficient than induction motors of comparable size and speed.

DC motors are powered by direct current. Individual motors can be precisely controlled over a wide speed range by properly varying either or both stator and rotor voltage. DC motors require a commutator and brushes or some means to switch power to the rotor because the rotor magnetic field has to remain stationary in space, thus, it rotates relative to the rotor. The commutators and brushes of DC motors are costly items requiring care and periodic repair. In many contemporary applications, variable speed AC motor/drive combinations are supplanting DC motors. These motor/drive combinations replace not only the DC motor, but the DC power source.

## Standard Motors Versus Energy-Efficient Motors

People speak of motors as either energy-efficient or not, but motor efficiency is not a bimodal feature. Within any given size and type of motor, efficiency of individual models varies over a continuous range from worst to best. The term "energy efficient" has only been formally defined for one sub-population of motors, albeit a large one. These are National Electrical Manufacturers Association (NEMA) Design A and B induction motors from 1 to 500 horsepower. In its October 1994 Revision #1 to *Standards for Motors and Generators*, NEMA defined an energy-efficient motor as one that equals or exceeds efficiencies provided in a table currently labeled 12-10. This table was previously designated as a "suggested standard for future design." It now is the official standard, replacing table 12-9 (formerly 12-6B).

Table 12-10 is broken down by horsepower, synchronous speed, and enclosure type (open or closed). Figure A-1 shows how motor models in one large category (1,800 rpm, 50 HP, TEFC) range in efficiency compared to the NEMA definition of energy efficient, 93 percent. Nearly half of

Figure A-1

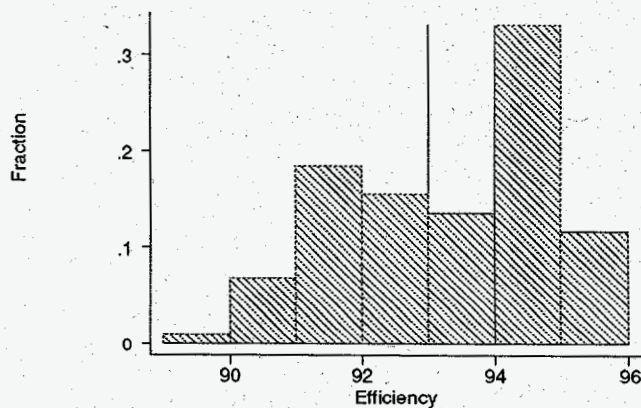

All 50 HP, 1800 rpm, TEFC Motors

the motor models currently produced *are* energy efficient by the NEMA definition.

The term "premium efficiency" is often used for motors exceeding table 12-10 efficiencies, but it is not officially defined by NEMA. Indeed motors with efficiency below table 12-10 sometimes use the term "premium efficiency" or other superlatives in their model name or product literature. "Energy efficient" is the only official terminology, but even this should be considered with caution. Because NEMA raised its standards, many motors that were properly classified as "energy efficient" before October 1994 no longer are. Individual models range continuously and widely. Purchasers should consult a comprehensive listing of motors and efficiency such as MotorMaster<sup>®</sup>, a computer program produced by the Washington State Energy Office (WSEO), to evaluate alternatives.

Are there side benefits or liabilities associated with energy-efficient motors? This question is often asked by skeptical plant managers. Generally, higher energy efficiency is associated with higher quality overall, but quality varies with other factors besides efficiency. Motor ruggedness and reliability vary with many things such as manufacturer, frame size, and any special service the motor was designed for.

Misinformation abounds regarding power factor, starting current, full load rpm, and reparability of energy-efficient motors. All of these factors vary randomly with respect to efficiency.

Power factor varies over a considerable range among competing models but it is not strongly correlated to the efficiency of those models.

Full load rpm is somewhat correlated to efficiency, with energy-efficient models averaging a fraction of a percent higher speed. Some users of pumps and fans, who know that those loads demand significantly more power when driven slightly faster, have overreacted to this correlation. Actually, there is considerable overlap of the rpm range of standard motors with that of competing energy-efficient models. For motor replacement, a more efficient motor with the same or even lower RPM can sometimes be found.

Contrary to myth, higher efficiency motors usually have no more locked rotor or starting current than their standard counterparts. Most are built to NEMA Design B standards, which place the same upper limit on all motors regardless of efficiency. There can be a greater difference in inrush current, which is often erroneously confused with starting current. Inrush current is the larger momentary current surge immediately following contact closure. It lasts for less than a hundredth of a second, in contrast to several seconds for locked rotor current. Higher efficiency motors tend to have higher inrush current due to their lower winding resistance. Because it is so brief, inrush current usually has less effect on a user's distribution system than the lesser magnitude locked rotor current. If high speed electronic protection devices are used, the high speed trip

current may have to be raised to accommodate more efficient motors.

Energy-efficient motors can be somewhat more difficult to repair, but this, too, varies by motor. Energy-efficient motors are constructed in much the same way as standard motors, although they contain a little more iron and copper, which can slightly increase the cost of materials when they are repaired. Sometimes new motors are wound with a tighter slot fill, which is harder to replicate, but this is not always limited to energy-efficient motors. Energy-efficient motors also may require a less common wire size or stranding or more than one size. About half of the shops surveyed said energy-efficient motors were harder to repair, but most gave examples of extra care that should be standard for repairing *any* motor regardless of original efficiency.

## Why Motors Fail

Any motor will fail eventually. Most motor failures occur earlier than necessary because of inadequate or improper lubrication, electrical system problems, or improper prior repair. Any conditions leading to overheating or moisture intrusion can cause early failure.

### Lubrication is very important.

Bearings can fail not just as a result of insufficient lubrication but as a result of improper lubrication. For example, regreasing with a grease different from the original grease can cause the mixture to break down and run out of the bearing. To prevent this problem, repairers should refer to grease compatibility charts or completely remove old grease. Contaminated grease can sign a bearing's death warrant. Even extremely small foreign particles can start a tiny pit in a bearing race, which slowly

grows each time a roller passes over. Several practices can contaminate grease: for example, particles can fall into open grease containers or particles from a dirty operating environment may get onto the grease fitting or grease gun nozzle and get injected into the bearing. Overgreasing can also cause a motor to fail; if a motor is overgreased, excess grease may be forced out of the bearing into the motor, a bearing seal may fail, or opportunities for contamination may simply be increased by overgreasing.

**Electrical system problems also shorten motor life.** Various overvoltage phenomena can cause motor insulation failure. For example, high voltage spikes from lighting or switching transients can break down insulation, or high-frequency voltage spikes can originate with a variable frequency drive (VFD), particularly if the cable length from drive to motor is long. Some motors have rotors that are much more vulnerable to overheating when powered by pulse-width modulated drive outputs. Voltage harmonics can reduce efficiency and cause overheating. Phase voltage unbalance can increase heating significantly and reduce motor efficiency. A 2 percent phase unbalance requires a 5 percent derating of the motor to prevent overheating.

**Improper repair can lead to early motor failure in many ways.** The most severe are winding errors or shortcuts. These can be errors in the winding pattern, substitution of smaller gauge wire, or changes in the number of turns. These practices tend to increase motor electrical losses, which in turn cause the motor to run hotter and stress the electrical insulation and bearing lubricant.

In the repaired motor, a well-documented cause of increased motor

losses and overheating is core iron damage. Core iron can be damaged if the temperature rises over 650° F when old windings are removed in a burn out-oven. It can also be caused by mechanical damage to the core that is not adequately repaired or *during* repair of the core.

Excessive vibration can shorten bearing life when an out-of-balance rotor or bent shaft are not corrected before reassembly.

Excessive vibration can also occur if poor machine work allows a rotor to be off-center in the stator bore.

Poor impregnation of varnish can cause either poor heat transfer or motion of windings under magnetic forces. Poor heat transfer can cause insulation to fail from overheating and motion of windings under magnet forces can cause insulation to fail from friction. Poorly restrained end turns are particularly vulnerable to acoustic vibration when powered by a VFD.

Moisture is often the cause of motor failure. Moisture can cause the electrical insulation to fail or it can corrode bearings. Obviously a motor exposed to falling or spraying water in excess of its enclosure rating is in peril. A less obvious problem is exposure to mere high humidity. Motors that are off long enough to completely cool down in high to moderately high relative humidity are at risk, even if they are totally enclosed motors. It is sometimes necessary to use space heat or dehumidification or provide internal heating to reduce the relative humidity of air in contact with motor insulation, especially for motors in storage. Unless their shafts are periodically rotated, stored motors can also suffer incipient bearing failure when lubricant drains or sags away from bearing surfaces and humidity causes rust pits.

Many of these adverse conditions cause overheating. There are other direct causes of overheating. The most obvious cause of overheating is overloading the motor, but dirt in the cooling passages is also a major cause of overheating. Operating a motor at high altitude or in hot environments contributes to overheating. Heat shortens insulation life; for every sustained 10° C increase, insulation life is halved. Heat destroys lubricant. It is important to note that anything that causes overheating also causes reduced efficiency and higher operating cost.

## **Additional Reading**

*Quality Electric Motor Repair: A Guidebook for Electric Utilities.*

*Buying an Energy-efficient Electric Motor.* Electric Ideas Clearinghouse—Technology Update, Bonneville Power Administration

*Energy Efficient Electric Motor Selection Handbook.* U.S. Department of Energy

*Horsepower: Implementing a Basic Policy for Industrial Motor Repair/Replacement.* Industrial Electrotechnology Laboratory & The North Carolina Alternative Energy Corporation

*Understanding A-C Motor Efficiency.* The Electrical Apparatus Service Association, Inc.

For information on any of these reference materials, contact the Motor Challenge Information Clearinghouse, P.O. Box 43171, Olympia, WA 98504-3171; Hotline (800) 862-2086; U.S. Department of Energy. Access and availability may vary depending upon user affiliations and current distribution policies of the author/organization.

# Appendix B

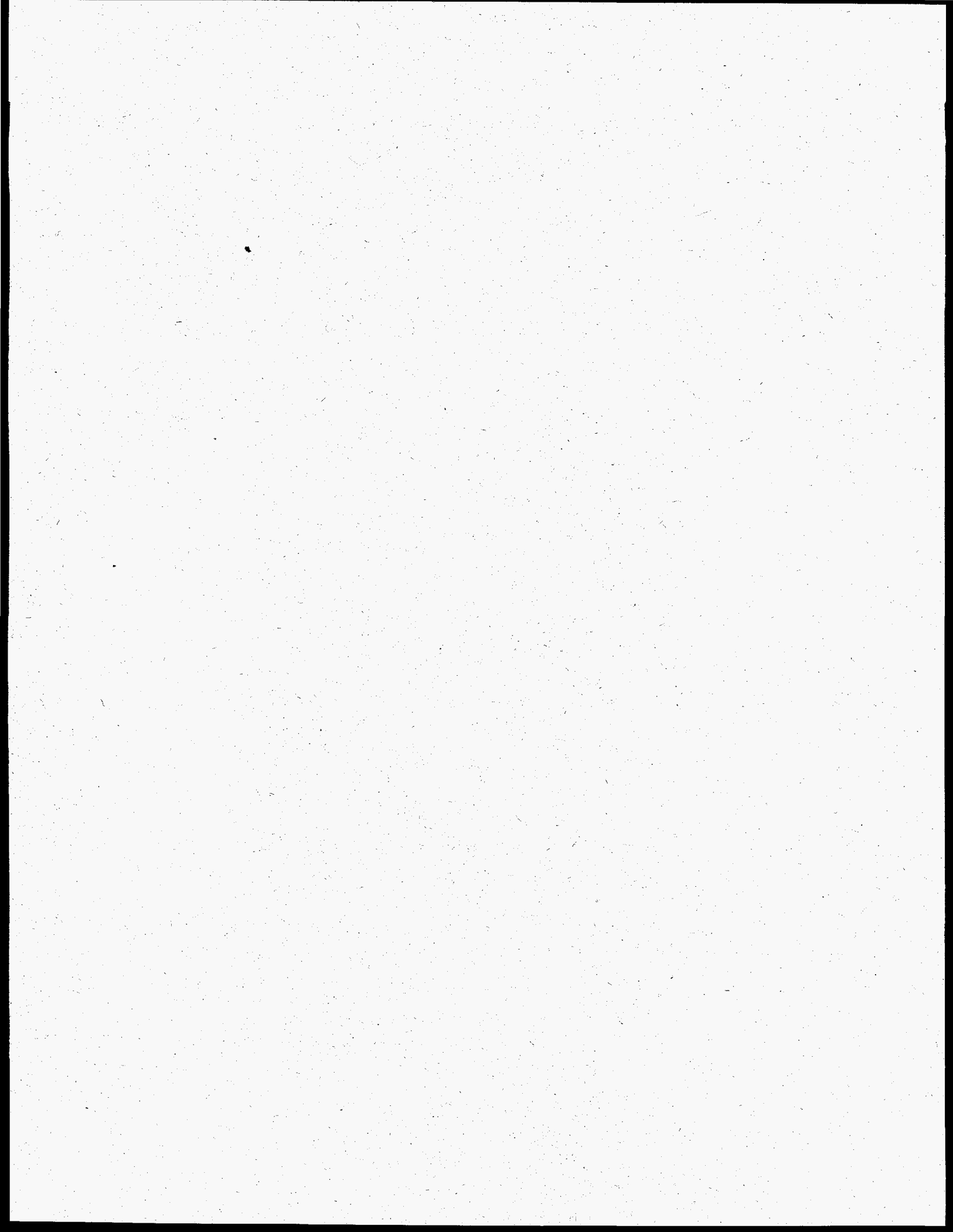

# The Motor Repair Process

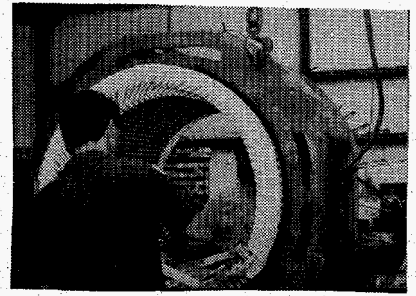

**P**urchasing motor repair is like making any other purchase. To be assured of quality at a reasonable price, repair consumers must be smart shoppers. Everyone understands price, but to be sufficiently informed, motor users must know something about the repair process. This fact sheet alone will not make you an expert, but it will provide a basic framework to build on.

*Motor repair varies with the extent of damage. This example is for an induction motor that has had a winding burn-out and also requires bearing replacement. This is not a detailed description of how to perform repair, but an overview of the process. It represents the typical major repair process, but some actual repair jobs will require special work because of special motor features or severe or unusual damage. These variations are not covered in this example.*

## Incoming Inspection

The motor is received and logged in. A motor repair form is filled out to identify the motor condition upon receipt and expected necessary repairs. A repairer's record or job card is prepared to accompany the motor through the repair process for documenting conditions found and both routine and special actions taken.

The motor is inspected initially to diagnose the problem, determine the probable cause of the problem, and determine what work is required. If the winding is not obviously defective, it will be tested for insulation integrity. The shaft is rotated manually to check for obvious bearing problems. If the motor is still operable, it will be run at full voltage with no load on the shaft to check for balanced current and vibration. Winding resistance is measured. Results are noted on the job file.

## Dismantling

When the motor is dismantled, mating surfaces are match marked, and small parts are stored for later reassembly. Conditions are noted and documented; for example, bearings are checked for electrical insulation method, configuration of vertical thrust bearings is recorded and axial and radial clearances are recorded.

After dismantling, core-loss testing is performed, using either a special commercial tester or a loop test, which is a setup with a watt-meter and AC current source. The core loss test excites the core from an AC current source with one or more turns of wire through the core. The repairer checks for hot spots, which usually indicate lamination shorting, and records wattage, i.e., core loss.

## Winding Removal

Windings are tightly bonded into the motor stator with various hardening resins or varnishes. These bonding materials are necessary for electrical insulation and good heat conduction and to prevent wires from moving and rubbing away enamel. To remove old windings, the varnish bond has to be defeated by burning, the use of chemical solvents, mechanical force, or a combination of these methods. Burn-out is the most common method used and will be described here.

To prepare the motor for burn-out, the end turns are cut off one end of the motor with a special saw. At this point, existing winding conditions are usually carefully observed and documented. Because it is often difficult to find this information in written records anywhere, the wiring pattern, number of turns, stranding combinations, and diameter of wire are recorded.

The motor is placed in a burn-out oven (not to be confused with the lower temperature varnish "baking" oven) and heated ideally to no more than 650° F. Burn-out ovens have temperature controls and most have a water injection system to prevent excessive temperature rises, which occur when insulation begins to burn. After several hours, when insulation has been burned sufficiently, the stator is removed and allowed to cool. With the varnish destroyed, old wire can be pulled out mechanically and recycled.

## Core Preparation

After burn-out, the core is cleaned and any damage is repaired. This process may include careful grinding or machining, spraying or locally inserting interlaminar insulation material, or even restacking core iron. The cleaned and repaired core is given another core-loss test to see if the core has maintained or improved its condition following the stress of burn-out and any subsequent repair actions.

## Rewinding

If the as-received winding configuration is suspect because of a prior repair, the nature of the failure, or pre-failure performance, it may be necessary to obtain winding data from records held by the manufacturer, EASA, or

the repair shop. If sufficient records are not available, the shop must redesign the winding configuration using engineering staff and/or support from EASA software and engineering staff. However, EASA software and staff time are not always sufficient to guarantee optimal design for all motors.

New windings are prepared on a special machine using magnet wire insulated with enamel. Motors require either random-wound (sometimes called mush-wound) or form-wound coils. For random winding, round wire is wound into loose, usually diamond shaped loops. Form-wound coils are wound in a similar way, but rectangular-cross-section wire is used. The wire is wound into orderly layers, shaped, then wrapped in insulating tape to form a rigid coil with very little wasted space. Formed coils are usually used on motors rated for over 600 volts.

The coils are manually inserted into the motor stators. Various special insulating materials are used to line slots, isolate coil groups, and secure end turns. Any temperature sensors are replaced at this time. Coil group connections are

brazed and lead wires are attached, and the motor is tested electronically to verify proper winding and connection.

To further stabilize and insulate the windings, the entire rewind stator is dipped in a varnish tank, removed, then baked to harden the varnish. A variation on this process involves a vacuum-pressure impregnation (VPI) varnish tank. With VPI, a vacuum is applied to expand and extract air bubbles, then pressure is applied to force varnish into all voids. Another variation is a trickle impregnation method wherein the stator is powered by a low-voltage DC current (to heat windings) and rotated while a heat-curing varnish is poured through.

## Rotor Repair and Testing

Induction motor rotors appear to be simple assemblies with no wires or moving parts. Nonetheless, a variety of problems can befall them, including lamination shorting, cracked squirrel cage bars, loose-swaged squirrel cage connections, bent shafts, and





out-of-balance conditions. These problems can be found by visual inspection, core-loss testing (using the shaft as the current conductor), or electromagnetic excitation with a device known as a growler. Certain electrical tests can also be done before disassembly with working motors.

Rotors are repaired using a variety of methods, as appropriate. Often there are no serious problems, but all rotors should be balanced. Balancing involves spinning the rotor on a special fixture with vibration sensors at the bearing points. A readout from the vibration sensors directs the repair person in placing balance weights.

## Bearings

Two kinds of bearings are in common usage, anti-friction bearings on smaller motors, and sleeve bearings on larger motors. Anti-friction bearings are ball or roller bearings. Sleeve bearings have no rolling parts; the shaft simply turns in a close-fitting babbitt alloy sleeve.

Anti-friction bearings are often routinely replaced whether they show evidence of deterioration or not. Severe problems with the shaft sometimes require shaft straightening, spray metalizing and re-machining. Problems with the end bells may require reboring and sleeving for the outer race. Worn or damaged sleeve bearings may require recasting the babbitt and machining to fit.

## Reassembly and Final Testing

Certain tests are performed during or after reassembly. If the stator has been rewound, the insulation is tested for resistance and a winding

resistance and/or surge comparison test is done to check for re-winding errors. The reassembled motor is connected and run at no load to verify balanced current at the rated level, vibration within standard limits, and temperature rise within normal limits. If the original failure involved bearing failure due to shaft currents, the repairer checks for a low shaft-to-frame voltage where one or both bearings are uninsulated. The motor is then painted and prepared for shipping.

Finally, records are completed, ensuring that the findings related to the failure are recorded along with all test results. The records are retained by the shop, usually for 10 or more years.

## Additional Reading

*Quality Electric Motor Repair: A Guidebook for Electric Utilities.*

EASA Standards for the Repair of Electrical Apparatus. The Electrical Apparatus Service Association, Inc.

*Tech Note No. 16: Guidelines for Maintaining Motor Efficiency During Rebuilding.* The Electrical Apparatus Service Association, Inc.

*Tech Note No. 17: Stator Core Testing.* The Electrical Apparatus Service Association, Inc.

*Horsepower: Implementing a Basic Policy for Industrial Motor Repair/Replacement.* Industrial Electrotechnology Laboratory & The North Carolina Alternative Energy Corporation

For information on these reference materials, contact the Motor Challenge Information Clearinghouse, P.O. Box 43171, Olympia, WA 98504-3171; Hotline (800) 862-2086; U.S. Department of Energy. Access and availability may vary depending upon user affiliations and current distribution policies of the author/organization.

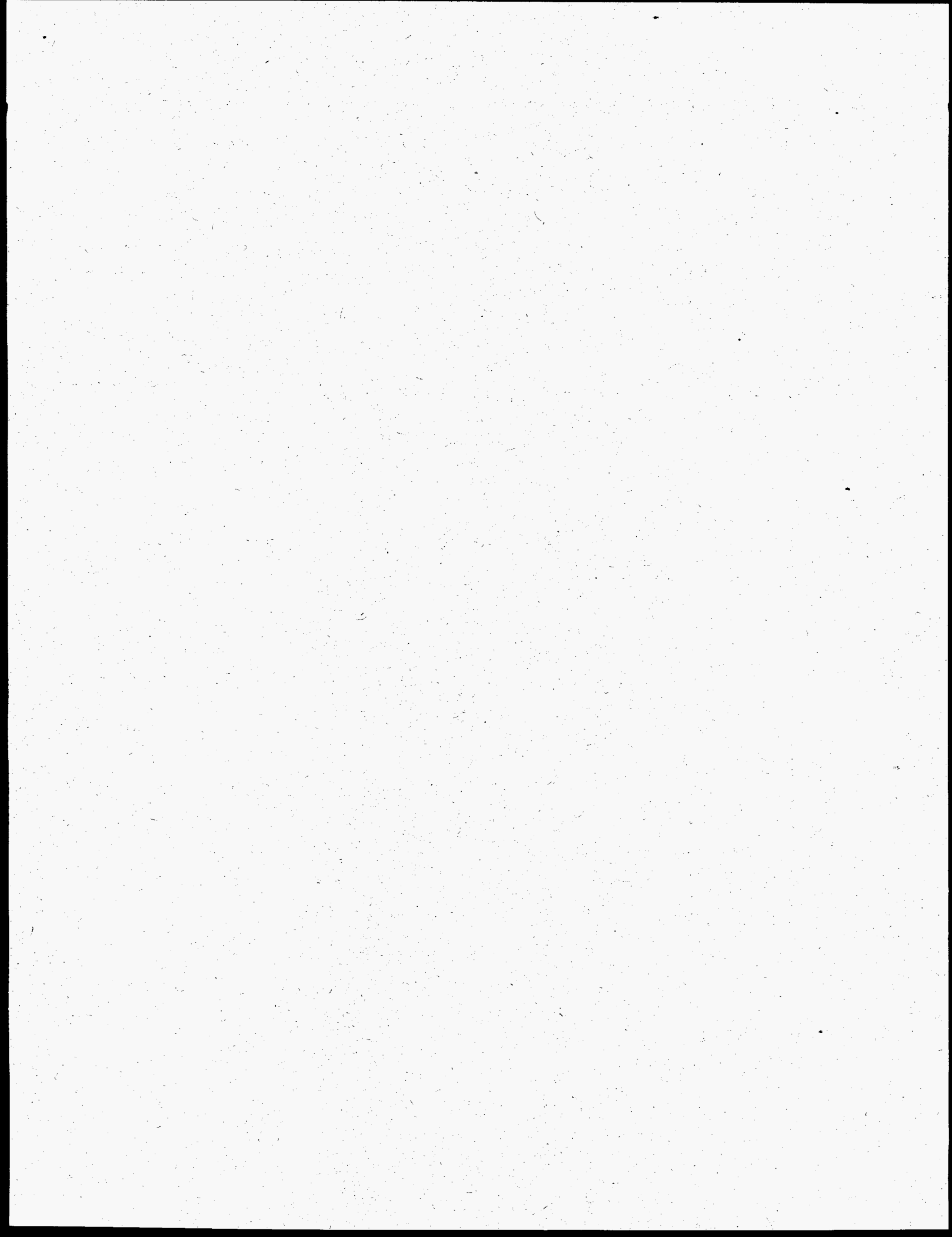

# Appendix C

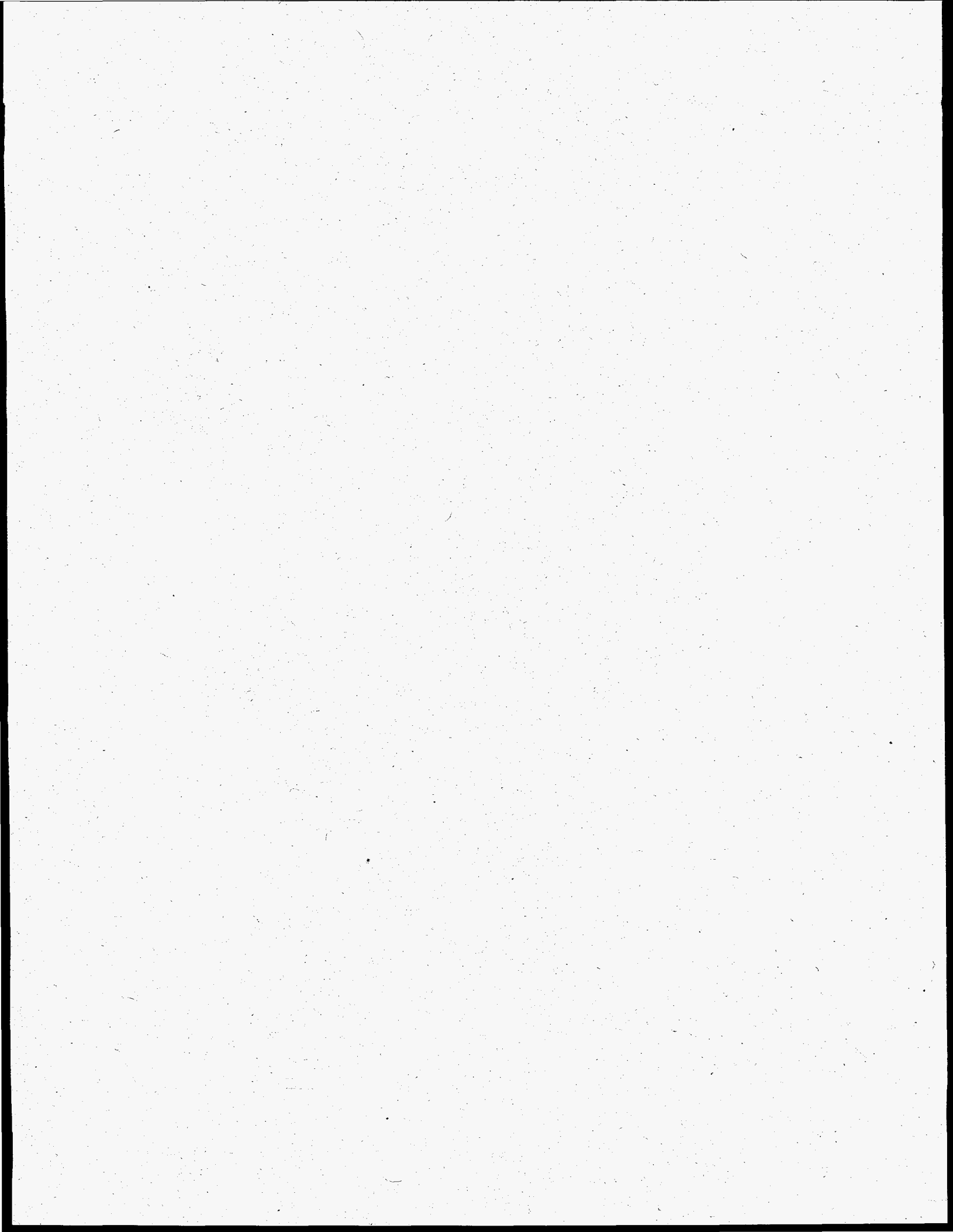

# How to Determine When to Repair and When to Replace a Failed Electric Motor

**T**he choice of rewinding a failed motor or replacing it with a more energy-efficient model can have a big impact on your bottom line. This fact sheet describes five important factors that should be considered and outlines a six step process for making the most economically advantageous decision for your situation.

## Background

Motor end-uses dominate electricity use in the commercial and industrial sector. In 1993, between 1.8 and 2.9 million motors over 5 hp (totaling over 200 million hp) were repaired in the United States. In the same year, over 2 million new motors were sold. The choice between replacing or repairing a failed motor comes up frequently. The choice is not trivial. Motor failure is often caused by insufficient maintenance, problems within the power system or controller, harsh environmental conditions, or problems with the driven load. Motor life can also be shortened by improper repair.

Premature failure due to poor quality repair affects your bottom line; so does the downtime accumulated while waiting for an unstocked motor to arrive. The annual energy cost of running a motor is usually several times greater than its initial purchase price. A typical continuously running 50 hp motor will use between \$10,000 and \$15,000 worth of electricity annually depending on utility rates in your area. This is four to six times its initial purchase price. Making the right choice matters.

Use these five questions to help you determine the most economically advantageous choice for your firm.

- How will the decision affect downtime?
- Is the motor repairable?
- What are the first cost differences between repair and purchase? (The first cost for repair is the repair price only; the first cost of motor purchase is purchase price only.)
- How will the decision affect operating costs?
- What are the differences in reliability for a new versus a repaired motor?

Analyzing costs and benefits in these areas will give you the information you need to determine which choice best meets your financial criteria.

## First Things First: Impact on Downtime

In most facilities the cost of lost production or customer inconvenience from downtime far outweighs any cost differences between repairing or replacing a failed motor. If a motor is critical to your operations and there are no spares available, the best option is usually the one that puts a well-functioning motor on line fastest.

Either option, repairing or replacing a motor, can be faster. A typical turn-around time for repairing a 50 hp motor, assuming parts are readily available and no machining is needed, is about three working days. A rush order can decrease turn-around time to two calendar days. Turnaround times are a day or two longer for motors over 150 hp because of longer process time requirements.

If you decide to replace a motor, the major concern is stock availability. Most general purpose open drip-proof (ODP) and totally enclosed fan-cooled (TEFC) motors under 100 hp will be available on the shelf. Non-specialty motors between 100 and 500 hp are often in stock at the manufacturers and can be rush ordered with two to four-day delivery. Specialty motors and motors over 500 hp may take up to several weeks to replace depending on the specification.

## Reparability

Repair cost will vary widely depending on the type of failure. Most motor failures result in seized bearings, winding burn out, and sometimes broken fans. Repairs for these problems are routine. If the failure results in holes melted in the stator core, cracked rotor bars, and bent shafts, repairs can get complex and require

restacking the core or extensive machine work. Repair costs rise accordingly. It is difficult for untrained persons to determine by casual inspection whether the repair problem is routine or more complex. If the economics of the repair decision are uncertain, the motor should be inspected and a repair bid prepared first.

## Purchase Versus Repair Cost

Motor horsepower and type strongly influence purchase and repair costs. The purchase price of new motors increases much more quickly with horsepower than the cost of a straightforward rewind/repair. A standard-efficiency 1,800 rpm, TEFC or ODP motor under 10 horsepower is more expensive to rewind than to replace. At 40 to 60 hp rewind costs for these motors are typically half the purchase price of a new energy efficient motor. When repair costs go below 50 percent of new motor costs, the repair option is usually taken. This point is called the repair point. Over the last 10 years the repair point has steadily moved from smaller to larger horsepower motors as labor costs increases raise rewind costs and new motor costs decline. This trend is expected to continue.

Purchase prices of explosion proof, vertical, high-slip, low-speed, multi-speed, and wound rotor motors are much higher than ODP and TEFC motors at a given horsepower. Specialty motor repair costs, however, are only moderately higher than general purpose motor repair costs. Therefore, the repair point for some specialty motors is at lower horsepower. In some cases, the repair point may be below 10 hp.

## Operating Costs

Energy costs are usually the biggest operating cost change. The change can be significant if the failed motor is replaced with an energy-efficient motor. When calculating energy costs, both possible decreases in the efficiency of the rewind motor and increases in the efficiency of the new motor should be considered.

Most motors can be rewound and repaired with little or no increase in losses if proper care is taken. However, quality control, labor, and materials vary significantly among shops. Case studies of repair involving over 50 motors in different parts of North America found decreases in full load efficiency of between 0.5 and 2.5 percent. Estimates of efficiency decreases after repair in a typical shop converged on about 1 percent. Unless you are certain that your repair shop follows stringent quality control procedures, assume some efficiency decrease after rewind.

Efficiency ratings for the replacement motor are available from the motor nameplate. Since the average efficiency level of standard-efficiency motors (below NEMA 12-9) has not changed in 30 years, simply replacing a motor with another standard-efficiency motor will save significant amounts of energy. If an energy-efficient motor is specified, savings can be large. A single point of efficiency gain for a continuously operating 50 hp motor with a 75 percent load factor saves between \$150 and \$200 annually depending on local rates.

## Reliability Concerns

It is unclear whether new energy-efficient motors or quality motor repairs are more reliable. Motor

salespersons argue that the overall quality of new motors is more consistent. There is a significant difference between the top and the bottom of the line. Standard efficient bottom-of-the-line motors generate more heat than energy-efficient motors and can fail earlier. Also, the cooling fans on energy-efficient motors that have to handle lower heating loads are not down-sized proportionately to the decreased heat load and are often slightly oversized. This improves heat dissipation. Finally, manufacturers often bundle energy-efficiency features in new premium-efficient motors with higher quality parts and features. These can also extend motor operating life.

New motors, like many products have a break-in period when maintenance problems and failures can be significant. If the failed motor does not have a history of failures, a new motor may actually increase maintenance time. The worst possible situation is to cycle through motors so quickly that maintenance staff are constantly breaking new motors in.

Repair shops claim they routinely upgrade insulation from Class A or B to Class F or H during rewind. This significantly reduces the likelihood of early failure due to exposure to high temperature. At face value, this practice seems positive, but it could help mask an efficiency degradation by keeping a repaired motor running longer in spite of higher losses.

No studies compare reliability of repaired and replaced motors. We expect the reliability of a quality repair and an new energy-efficient motor is on par. Both are more reliable than a poor quality repair or a standard-efficiency motor.

## Putting It All Together

We recommend a six-step process for deciding to repair or replace a failed motor.

### Step 1: Address Downtime Considerations

If the failed motor drives critical equipment and no back-up motor is available the most important question is, "Which approach results in the least amount of downtime?"

Availability and turn-around will vary seasonally and locally so call both your motor repair shop and motor supplier to get firm delivery dates. When asking for repair turn-around times be sure to ask how long will it take to get the rewind done right. Pushing the repair shop too hard may result in a hasty repair, and quality may suffer. A poor quality rewind or repair leads to higher operating costs and premature failure.

### Step 2: Assess Whether Current Motor is Optimal for the Application

If the motor failure is not on a critical path, this is the time to assess whether the failed motor was the most optimal for the application. Can a more energy-efficient model be used? Is an energy-efficient model available in the size, speed, and features needed? Can the motor be resized? Issues around resizing motors are complex. A good source to consult is the *High Efficiency Motor Selection Handbook* and fact sheet from the Motor Challenge Program. (See Additional Reading.) If a more optimal motor is feasible and available, it

should be used as the new purchase comparison.

### Step 3: Determine if a Detailed Analysis is Needed

Analyzing the motor repair/replace option comprehensively and obtaining bids for repairing or replacing a motor is a resource-intensive process. For some combinations of motor types, sizes, and operating conditions, the cost advantages of either the repair or the replace option are so clearly superior that a detailed analysis may not be needed. Here are some rules of thumb to guide the decision. Considering only first costs and energy costs, it is almost always more economically attractive to:

- Consider rewinding/repairing a specialty motor. They are considerably more costly to purchase new and are less likely to be in stock.
- Replace non-specialty motor under 15 hp. Repair/rewind costs are equal to or higher than a new motor and these motors are more likely to be in stock.
- Rewind motors over 100 hp. New motor costs rise steeply above 100 hp and energy efficient replacements are less likely to be stocked, although in areas with high utility rates, it may be worth analyzing the replacement option for heavily used motors up to 150 hp.

### Step 4: Obtain Bids

If either option is not clearly ruled out at this stage, obtain bids from both the new motor supplier and the repair shop.

If you are unfamiliar with the work of a repair shop, provide them with a copy of a quality re-

pair specification, such as the *Electric Motor Repair Specification* developed by EPRI, Bonneville Power, and the U.S. Department of Energy. Alternatively, ask whether the shop uses EASA-Q or other quality assurance standards.

Adjust new motor purchase cost to include dealer discounts and utility motor rebates if they are available. Do not overlook additional installation costs. Changes in the speed, horsepower, and frame may require changes in wiring, new mount, belt, sheaves, pulleys, and other installation modifications.

### Step 5: Calculate Energy Savings

The formulas for calculating differences in energy cost are:

#### Equation 1

$$\text{Energy Cost Savings} = \text{Hours of operation} * \text{hp} * \text{Load} * .746 * (100/(ERr - IL) - 100/ERn) * EC$$

#### Equation 2

$$\text{Demand Cost Savings} = \text{hp} * \text{Load} * .746 * (100/(ERr - IL) - 100/ERn) * \text{MDC} * \text{NM}$$

Where:

Load = Average motor load

ERr = Original Pre-Failure Efficiency Rating for the rewound motor

IL = Reduction in efficiency (percent) that results from rewinding

ERn = Efficiency Rating of the New Motor

EC = Local energy charge (Cents/kWh)

MDC = Monthly Demand Charge

NM = Number of months demand charge applied

If you do not have the efficiency rating of the failed motor (ERr), a reasonable substitute is the average standard-efficiency motor (not meeting NEMA Standard 12-9) in 1994. The average efficiency of available standard-efficiency motor brands has not changed significantly over 30 years. This value can be found in MotorMaster® software. A useful rule of thumb for estimating typical efficiency losses from rewinding is an 8 percent increase in losses (1-Efficiency Rating) over pre-failure conditions. Zero can be used if the repair shop has demonstrably effective quality assurance programs.

Reliable data for the hours of operation and motor load inputs (which drive the calculations) are often not readily available. While hours of operation can be measured fairly easily, there are currently no low cost field approaches for measuring load. Motors typically run at peak efficiency near

75 percent of full load. In the absence of better information this is a conservative assumption to use.

### Step 6: Calculate Financial Impacts

Net present value or simple payback methods can easily be adapted to this problem. The basic form for calculating the simple payback for a high efficient replacement over repairing the motor is:

#### Equation 3

$$\text{SPB} = \frac{\text{NC} + \text{IC} - \text{RWC} - \text{UR}}{\text{ECS} + \text{DCS}}$$

where:

SPB = Simple Payback

NC = New motor cost - dealer discounts

IC = Incremental installation costs (if any)

RWC = Rewind/Repair Cost

UR = Utility Rebate (if available)

ECS = Energy Charge Reduction (see Equation 1 above)

DCS = Demand Charge Reduction (see Equation 2 above)

NPV approaches provide a more flexible means to deal with the time value of money. We recommend that the benefit stream from energy costs be limited to 5 years, a conservative estimate of the time until next failure. If the motor is operating in a dirty or corrosive environment the benefit stream should be reduced further.



## Example

A 50 hp 1,800 rpm TEFC motor has failed at ACE manufacturing. A spare motor is available so down-time is not a consideration. The motor runs 12 to 15 hours a day (5,000 hrs/yr) and does not appear to be significantly under or over loaded. Since the local utility offers a rebate for premium-efficiency motors, ACE gets a bid on a premium efficient model with a 3/4 load efficiency of 95 percent. The purchase price including a 25 percent dealer discount is \$2,550. The utility rebate is \$8/hp or \$400. Local utility rates are \$.05/kWh for energy and \$9.00/kW for demand.

The original efficiency of the failed motor, still legible on the nameplate, is 91 percent. After inspecting the failed motor the repair shop finds bearings need to be replaced. The bid on the repair comes in at \$1,100. ACE is not familiar with the quality control of the shop. They assume an 8% increase in losses, which is a 0.72% efficiency decrease.

$$\begin{aligned}\text{Energy Savings} &= 5000 \text{ hrs} \times 50 \text{ hp} \times .75 \text{ (load)} \times .746 \times (100/(91 - .72) - 100/95) \times \$.05/\text{kWh} \\ &= \$384.89\end{aligned}$$

$$\begin{aligned}\text{Demand Savings} &= 50 \text{ hp} \times .75 \text{ (load)} \times .746 \times (100/(91 - .72) - 100/95) \times \$9.00/\text{kWh} \times 12 \text{ (months)} \\ &= \$166.27\end{aligned}$$

$$\begin{aligned}\text{Payback} &= \frac{\$2,550 - \$1,100 - \$400}{\$384.89 + \$166.27} \\ &= 1.9 \text{ Years}\end{aligned}$$

The energy savings from replacing the failed motor with a premium efficiency motor will pay back the costs of the new motor in 1.9 years. The net present value, assuming a 20 percent discount rate and five years of energy savings is \$928.

## Additional Reading

*Quality Electric Motor Repair: A Guidebook for Electric Utilities*

*Buying An Energy-efficient Electric Motor*. Electric Ideas Clearinghouse  
Technology Update, Bonneville Power Administration

*Energy Efficient Electric Motor Selection Handbook*. U.S. Department of Energy

For information any of these reference materials, contact the Motor Challenge Information Clearinghouse, P.O. Box 43171, Olympia, WA 98504-3171; Hotline (800) 862-2086; U.S. Department of Energy. Access and availability may vary depending upon user affiliations and current distribution policies of the author/organization.

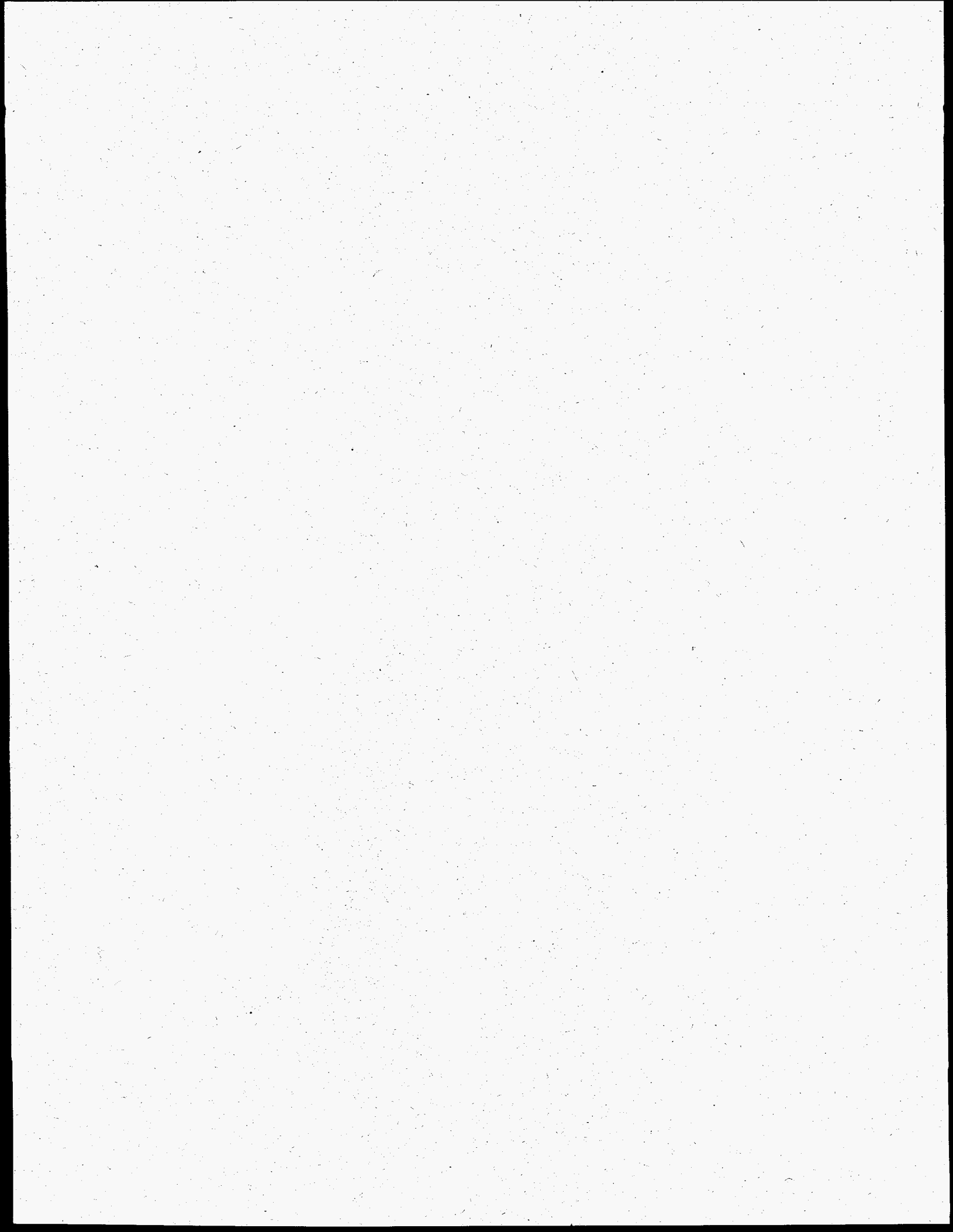

# **Appendix D**

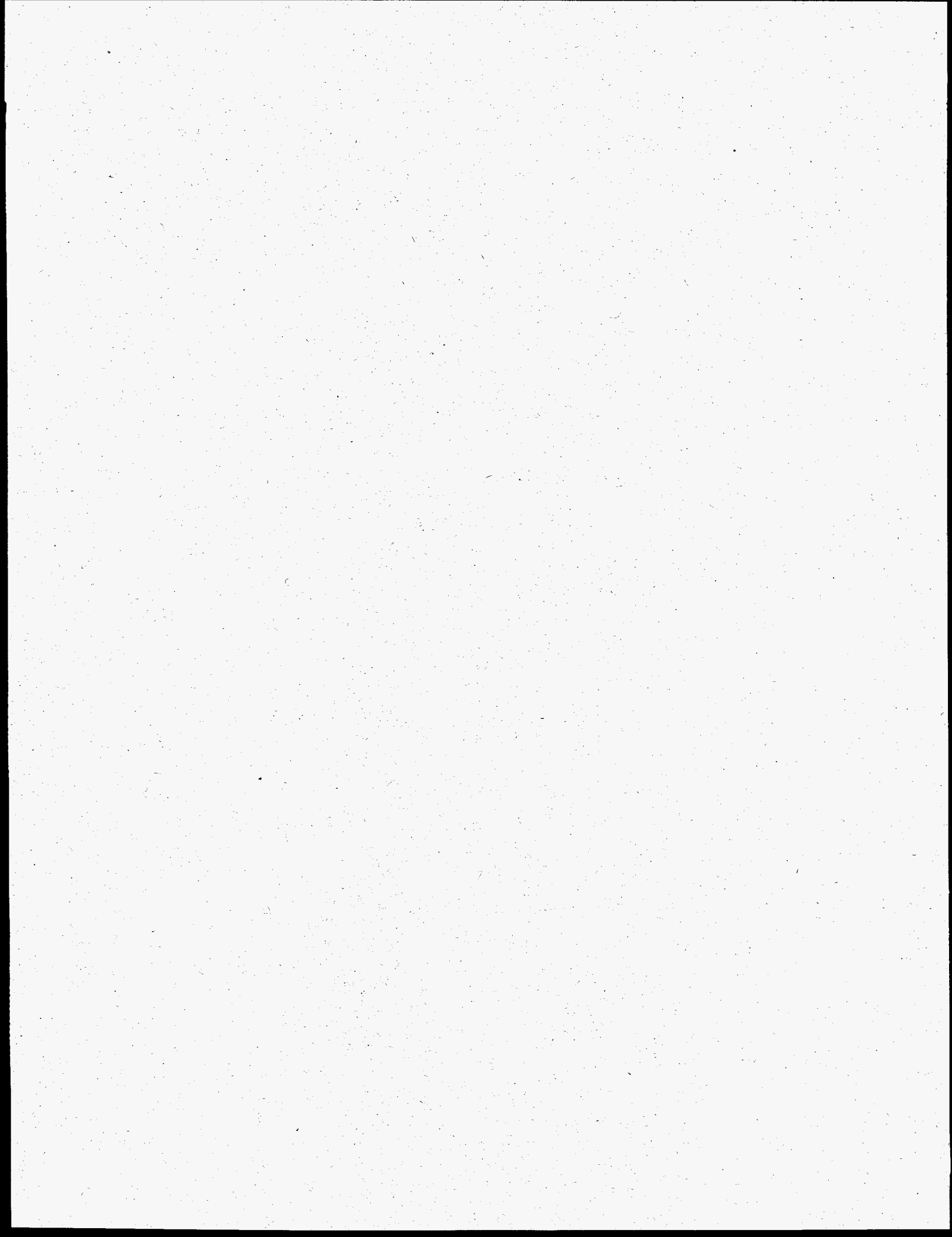

# Evaluating Motor Repair Shops

**M**ost users want to purchase a quality repair job, but what is quality? Quality means more than having the outside and inside of the motor be neat and clean. Errors and careless workmanship reduce efficiency and shorten the life of a repaired motor.

To be assured of a quality product, customers of motor repair shops need to clearly understand the service they're purchasing. It is certainly important to have a specification outlining the expected scope and quality of work. However, nothing can ensure quality work if the shop is not capable of it, so the most important thing a smart shopper does is carefully select a competent and reputable shop.

An important starting point in choosing a shop is to assess whether it does significant repair work with the type and size of motors you are likely to have repaired. If the motors you have repaired are mostly small induction motors, you might want to avoid a shop whose bread and butter is locomotive motor/generator sets. If you have many motors over 600 volts, you might want to avoid a shop that handles motors that are mostly 460 volts and under. Working with a shop outside its primary market niche may lower quality or increase price. Customers with a wide range of motor types may benefit from qualifying two or more repair shops.

## Obtaining Information

The following elements can help customers determine a shop's ability to deliver quality work:

### ■ Tools and facilities inventory

Facilities must be in place for handling the largest motors you expect to submit. Winding heads sufficient for duplicating original winding patterns must be present. Thorough diagnostics and verification of correct repair is difficult without certain equipment like a surge tester and a well regulated power supply.

### ■ Repair materials inventory

A variety of materials are used for electrical insulation in motor repair. These materials include slot liners, wire sleeves, special paper separators for coil groups, and material for tying and restraining end turns. Most shops stock only class F or class H insulating materials, which often exceed original insulation heat ratings. These materials are often cited as higher quality, but they are also cheap insurance for poor repair because they better tolerate overheating, which can result from degraded efficiency. Shops that do not have a good inventory of wire sizes in stock should be able to explain how they get restocked quickly or provide stranding combinations for maintaining original wire cross-section.

### ■ Staff stability, training, experience, and morale

A knowledgeable staff is important. Many shops hire personnel with motor repair training from the military and provide further on-the-job training. Others actually prefer new hires with no prior experience so they can train them "right" from the start. Some repair shops are family businesses with multiple generations and good mentoring of younger staff. A low turnover rate can indicate employee satisfaction and management's willingness to invest in staff.

### ■ Record keeping system

Good record-keeping is very important. Motor management is akin to health care. A record of past problems and remedies can be invaluable for diagnosing or preventing new problems and resolving any warranty issues. An elaborate computer system may be impressive, but many shops make thorough records on job cards that can be kept for many years.

## ■ Cleanliness

Cleanliness is often associated with good quality management. Cleanliness is more than an aesthetic matter. Most material and supplies used in a motor shop need to be protected from contamination; tools and test equipment need to be organized so they can be found when needed; gauges and testing equipment need to be put away or protected from damage when not in use to maintain calibration. Locations where bearings and lubricants are stored or installed must be very clean because even very small particle contamination can be a time bomb that can cause premature bearing failure.

## ■ Standard operating procedures

Evidence of a system for maintaining quality is important. Ideally this system will include a formal quality management system involving third party inspection and certification. These are still rare, but they may become more commonplace with the Electrical Apparatus Service Association's (EASA's) promotion of the EASA-Q quality management system and increasing awareness of ISO 9000 quality management standards. Shop managers should be able to point to documents that provide standards, operating procedures and important records, such as bearing-fit standards, testing procedures, forms for record-keeping, and calibration records.

Determining whether a shop provides quality workmanship can be time-consuming. However, a careful evaluation will include both an interview and an inspection. To ensure comprehensive investigation, a suggested checklist is provided

at the end of this fact sheet. This list can be completed during the interview and annotated as necessary during the walk-through inspection. Smaller customers of repair services may not find it necessary to complete the checklist formally; however, the list can help repair customers understand the equipment and practices that are important in quality motor repair.

Some items on the checklist are less likely to be present in small or specialty shops. For example, your shop may not have a 10-ton crane. Obviously, this is no problem if you only intend to have the shop repair motors under 50 hp. Other items may not be present, but the shop provides them by subcontracting the service. If your shop subcontracts services that you will use, discuss the reasons for subcontracting those services and inspect the subcontractor's facility.

## Conducting the Evaluation

Make an appointment for evaluating the shop in advance, reserving at least half a day. Advise the shop manager that this is part of a structured evaluation and that he or she may be asked to produce evidence for such things as employee training or equipment calibration practices. The evaluator should attempt to make the shop manager feel comfortable. Allow the manager to explain answers, and do not hesitate to diverge from the written checklist to pursue a better understanding of shop practices, staff knowledge, or commitment to quality. Avoid reactions that make it appear that you are making an evaluation on the spot.

It is important for the evaluator to be well-informed. A familiarity with motor construction and meth-

ods and issues in motor repair are important. The interviewer should have thoroughly reviewed the *Quality Electric Motor Repair: A Guidebook for Electric Utilities*.

Depending upon the size of your potential business and your preferred interview style, you can consider variations in approach to the interview. Some customers may wish to provide the checklist to shop managers in advance of the interview. Alternately, it can be withheld if you feel that it would discourage candid responses. If it is withheld, the shop manager should be advised of the scope and general content of the list so that he or she does not feel "blind-sided" and become uncooperative.

For your convenience, a commentary regarding desirable responses is placed in the right margin of the checklist. If you are concerned that the shop manager will see this and stretch for a "correct" response, the responses can be masked when the form is photocopied.

The first two parts of the checklist assess shop capability. They assess capacity capability and specific capability. Capacity pertains mainly to the size of motors that can be accommodated. Specific capability pertains mainly to the ability of the shop to do certain repairs that may not routinely be part of all motor rebuilds. Limitations of these capabilities do not necessarily indicate efficiency or quality problems for repair jobs that do not require those capabilities.

The third section of the checklist pertains to procedures and practices that are likely to affect quality of repair for any motor. These categories are not a perfect segregation of capability versus quality. The absence of large sizes of certain tools may be a capability factor, whereas total absence of the tool would be a quality factor.

# Motor Repair Shop Checklist

## Capacity Capability (for multiple devices, list maximum capability of each)

Crane Size \_\_\_\_\_ tons \_\_\_\_\_ hook height

Hydraulic Bearing Puller capacity \_\_\_\_\_ tons

Truck Capacities \_\_\_\_\_ 1/2ton \_\_\_\_\_ 3/4ton \_\_\_\_\_ 2ton \_\_\_\_\_ 6ton

Door Height \_\_\_\_\_

Burn-Out Oven Internal Size \_\_\_\_\_ H \_\_\_\_\_ W \_\_\_\_\_ D

Dip Tank, depth \_\_\_\_\_ diameter \_\_\_\_\_

VPI System;

depth \_\_\_\_\_ diameter \_\_\_\_\_, pressure capability \_\_\_\_\_ psig, vacuum capability \_\_\_\_\_ in Hg.

In-Shop Dynamic Balancing Capability. Check all rotor weights that can be balanced:

- \_\_\_\_ 25 lb
- \_\_\_\_ 100 lb
- \_\_\_\_ 1,000 lb
- \_\_\_\_ 5,000 lb
- \_\_\_\_ 10,000 lb
- \_\_\_\_ 20,000 lb

What three-phase, line-to-line voltages can shop provide for motor testing?

- \_\_\_\_ 208
- \_\_\_\_ 230
- \_\_\_\_ 460
- \_\_\_\_ 575
- \_\_\_\_ 2,300
- \_\_\_\_ 4,160
- \_\_\_\_ 5,000
- \_\_\_\_ DC; voltage range \_\_\_\_\_

Is power supply voltage continuously variable? \_\_\_\_\_

Can power supply reliably control phase balance to within 1%?

## Specific Repair Capability

Check services offered:

- \_\_\_\_ Random-wound polyphase AC motor repair
- \_\_\_\_ Form-wound polyphase AC motor repair
- \_\_\_\_ DC motor repair
- \_\_\_\_ Servo Motor repair

## Procedures, Practices, and Inventories

What primary methods of winding removal are used?

Controlled burn-out; typical temperature \_\_\_\_ F. (If sometimes higher, explain circumstances.)

Chemical stripping

Mechanical pulling at temperature under 400° F

Other

How many different round wire sizes are present in inventory? \_\_\_\_

What does shop do if exact wire size is not in inventory?

On random-wound motors, is winding pattern ever revised for reasons other than customer ordered re-design? \_\_\_\_\_

If yes what changes?

lap to concentric

concentric to lap

other (explain)

Why are changes made?

How many employees have the following years of experience?

Over 8

4 to 8

Under 4

What sort of supplemental training or professional development activity is offered to shop floor employees? (Obtain evidence if possible.)

In-house training or structured mentoring (Describe)

Off-site short courses, workshops or seminars one or more days in length

Subsidized evening or part time classes at college or trade school

Attendance at trade conferences or conventions

Other

How often do shop-floor employees get training or professional development benefits?

Average days off-site per year per employee

Annual expenditure per employee

In what trade or professional associations does shop have membership? \_\_\_\_\_

What temperature classes of insulation are stocked and used? \_\_\_\_

What (if any) kind of core-loss testing does shop use?

loop or ring test; max kva \_\_\_\_

Commercial tester Phenix brand; max kva \_\_\_\_

Commercial tester Lexeco brand; max kva \_\_\_\_

Other (describe)

Burn-out most common. Best if under 650° F.

Mechanical pulling at reduced temperature can be good. It is rare in U.S. 15 minimal; 25 good

Evidence of quick access to supplier desirable.

Not desirable to revise pattern for convenience. A conversion from concentric to lap is often done, but should be avoided.

Desirable to have 20% or more with over 4 years experience.

Participation in EASA training is commendable. Generally, any sort of training is desirable.

One or more days off-site desirable. \$300 or more per employee desirable.

EASA membership is a definite plus, though very large shops may have in house capability to provide same.

F or H desirable.

Any commercial tester is evidence that shop is conscientious about core losses. Loop testing per EASA guidelines may be comparable to commercial testers if performed correctly.



How are results used? List all that apply.

- Check for hot spots to be repaired
- Note watts per pound and compare to a standard
- Document impact of burn-out/rewind to customer

Is no-load testing done on all motors?

Equipment Calibration

Item	Normal interval	Date last calibrated or certified
------	-----------------	-----------------------------------

Ammeters

Annual

Wattmeters

Annual

Core Loss Tester

Annual

Burn-out oven temp.

Annual

Ring Gage

This should be a certified standard for calibrating bore gages.

through size 312

through size 318

Bore Gage

Calibrated to a ring gage before and after each use.

through size 312

through size 318

Micrometer

Three months on micrometers and vernier calipers. May be done in-house to a certified standard. Standard blocks must be kept clean and dry and show no sign of damage or corrosion

1"

2"

3"

4"

5"

6"

7"

etc.

Vernier Calipers

range

\_\_\_\_\_

\_\_\_\_\_

\_\_\_\_\_

\_\_\_\_\_

etc.

Vibration Analysis Equipment

Annual

Brand \_\_\_\_\_

Model \_\_\_\_\_

Surge Comparison Tester

Annual

Brand \_\_\_\_\_

Model \_\_\_\_\_

Hi Potential Tester (HiPot)

Three months to a certified standard resistance.

Brand \_\_\_\_\_

Model \_\_\_\_\_

AC rating \_\_\_\_\_

DC rating \_\_\_\_\_

Megohmmeter

Three months to a certified standard resistance.

Brand \_\_\_\_\_

Model \_\_\_\_\_

Certainly check for hot spots. Noting watts per pound and comparison to standard or before and after testing is commendable.

This should be done. If not, determine why not.

## Equipment Calibration

Item	Normal interval	Date last calibrated or certified
------	-----------------	-----------------------------------

Milli or Micro Ohmmeter

Brand \_\_\_\_\_

Model \_\_\_\_\_

Lowest Resolution \_\_\_\_\_

What percent of motor rewind jobs get core loss testing both before and after rewinding. \_\_\_\_\_%

Varnish and resins

spec. \_\_\_\_\_

spec. \_\_\_\_\_

spec. \_\_\_\_\_

spec. \_\_\_\_\_

spec. \_\_\_\_\_

Library: Check all the following documents which are present

Document

Latest Revision Date

NEMA MG1 Motors and Generators

NEMA RP 1 Renewal Parts of Motors & Generators

ABMA Std 7 Shaft & Housing Fits for Metric Radial Ball & Roller Bearings

ABMA Std 20 Metric Ball & Roller Bearings Conforming to Basic Boundary Plans

ISO 1940/1 Mechanical Vibration - Balance Quality Requirements of Rigid Rotors Part 1

ISO 2372 Mechanical Vibration of Machines with Operating Speeds From 10 to 200rev/sec

ISO 9000, -1, -2, -3, -4 Quality Management And Quality Assurance

IEEE Std 43 Insulation Resistance Testing

IEEE Std 112 Polyphase Induction Motor Testing

IEEE Std 113 Test Procedure for DC Machines

IEEE Std 432 Insulation Maintenance

IEEE Std 1068 Petroleum & Chemical Industry Motor Repair (1)

UL 674 Rebuilding Explosion Proof Motors (1)

EASA Technical Manual (2)

EASA Winding DATA (2)

EASA Warranty (2)

EASA Standards (2)

(1) Not applicable for shops which do not serve this market

(2) Non EASA members should produce equivalent documents or file material.

How long does shop keep records on each repaired motor? \_\_\_\_\_

(Obtain sample copy of filled in job card or computer printout.)

Annual

Ideally 100%. Explain lower percentages.

Sample should have been taken and analyzed to be satisfactory every two months. Manufacturer's material specs. should be on file.

## **Additional Reading**

*Quality Electric Motor Repair: A Guidebook for Electric Utilities.*

EASA Standards for the Repair of Electrical Apparatus. The Electrical Apparatus Service Association, Inc.

*Tech Note No. 16: Guidelines for Maintaining Motor Efficiency During Rebuilding.* The Electrical Apparatus Service Association, Inc.

*Tech Note No. 17: Stator Core Testing.* The Electrical Apparatus Service Association, Inc.

For information on any of these reference materials, contact the Motor Challenge Information Clearinghouse, P.O. Box 43171, Olympia, WA 98504-3171; Hotline (800) 862-2086; U.S. Department of Energy. Access and availability may vary depending upon user affiliations and current distribution policies of the author/organization.

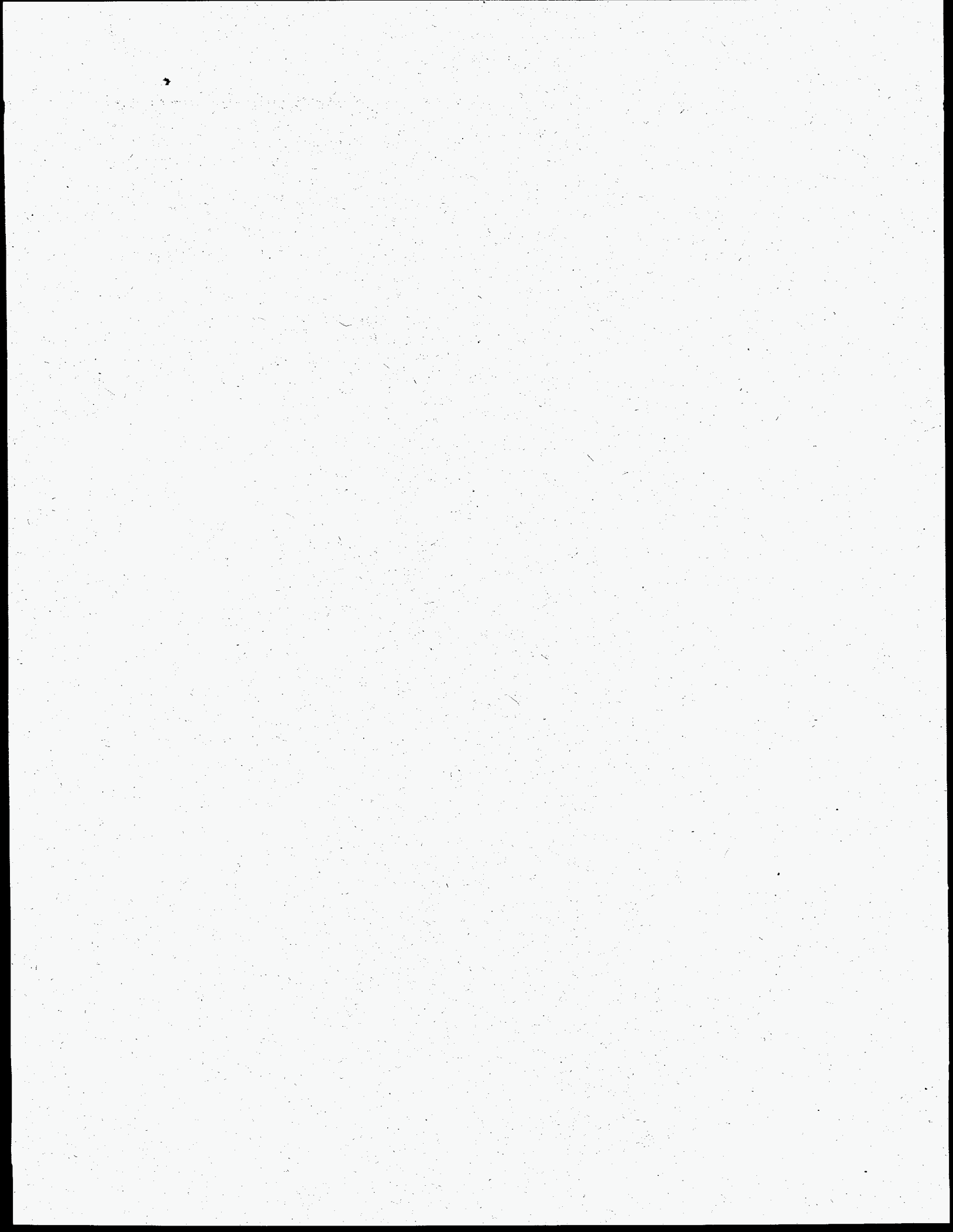

# **Appendix E**

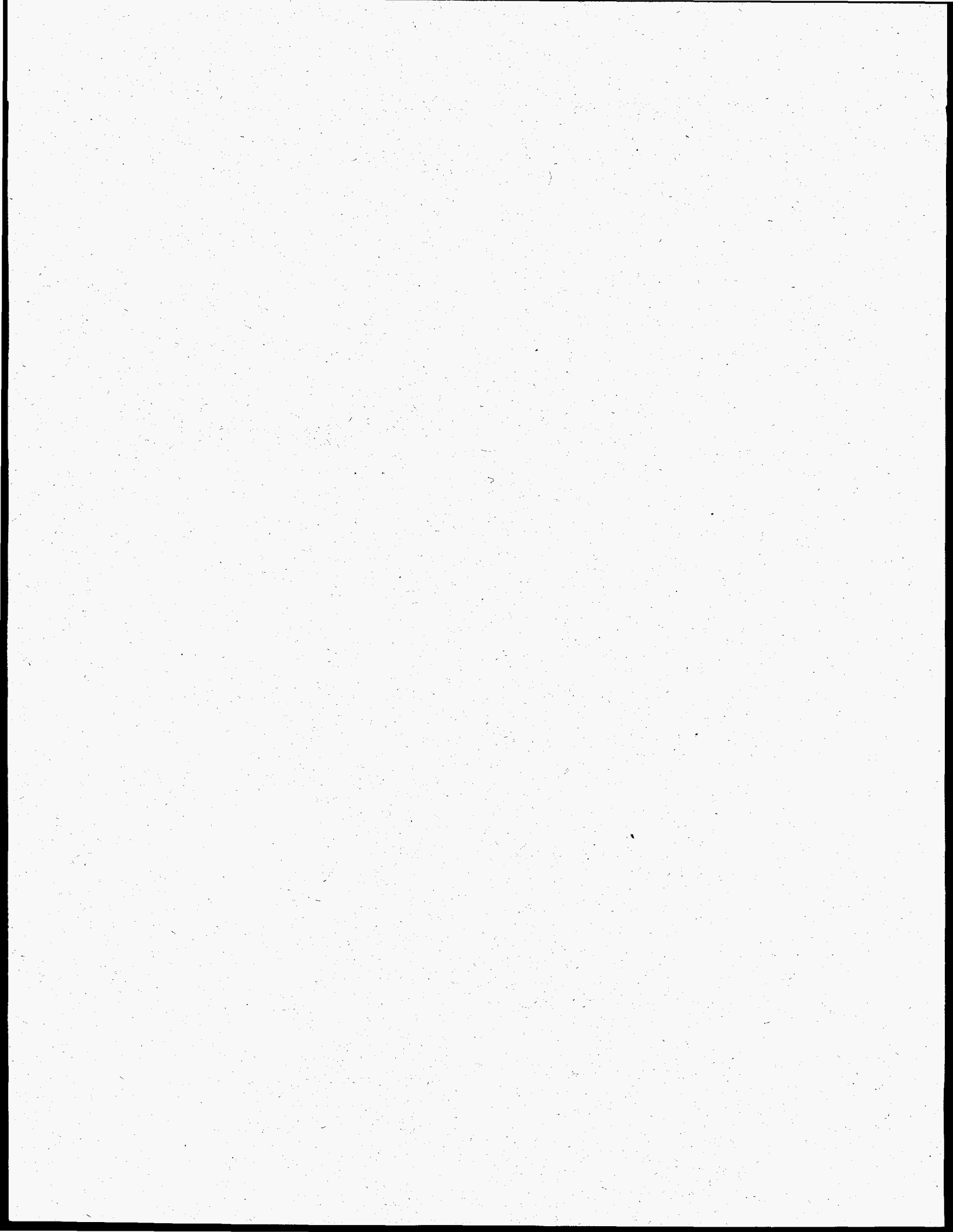

# Selected Bibliography on Electric Motor Repair

- Bernow, Steve, Frank Ackerman et al. "Direct Environmental Impacts of Demand-Side Management." *ACEEE 1992 Summer Study on Energy Efficiency in Buildings*, ACEEE, 1992. p. 9.23-9.24.  
Broadly discusses environmental impacts of DSM. Includes a good section on the comparative environmental impacts of motor rewinding vs. new motor manufacture.
- Bishop, Thomas H. "Motor Repair Industry Response to the Energy Policy Act of 1992: A Status Report." *Proceedings of the 21st Electrical Electronics Insulation Conference*, 1993. p. 105-108.  
Summary of actions taken primarily by EASA responding to legislation and issues pertaining to rewind motor efficiency.
- Brethauer, Dale M., Doughty, Richard L., and Robert J. Puckett. "The Impact of Efficiency on the Economics of New Motor Purchase, Motor Repair, and Motor Replacement." *IEEE Proceedings of the Petroleum and Chemical Industry Conference*, 1993. p. 37-50.  
Provides economic analysis tools for choices involving new motor purchase, motor replacement, or repair.
- Brithinee, Wallace P. "Electric Motor Repair Industry Update." *IEEE Electrical Insulation Magazine*, July/August 1993. p. 23-24.  
Summary of current issues and research pertaining to motor repair.
- "Can Rewinding Hurt Motor Efficiency." *Production Engineering*, June 1985. p. 100-102.  
Summarizes EASA Core Loss Study results.
- "A Cheap Rewind of a Motor is No Bargain." *Production Engineering*, February 1985. p. 10.  
Report on study by GE of increased core losses from poor quality rewinds.
- Cohen, Michael. "Predictive Maintenance of Operational Motors Using Digital Data Collection and Trend Analysis." *Tappi Journal*, January 1991. p. 151-155.  
Recommendations and examples of predictive motor maintenance based on recording data and analyzing trends.
- Craig, Bill. "Positive Fault Identification Using Surge Testing." *EC&M*, September 1984. p. 40.  
Describes "Surge Test" technique. This technique is used to detect errors in the rewind motor as well as diagnosing faults in failed motors.
- Dalrymple, Murray. "PM Programs Reduce Motor Failures." *EC&M*, October 1984. p. 34 & 175.  
Describes testing and inspection of motor relay, circuit protectors & fuses.
- Darby, E. Steve. "Electric Motor Rewinding Should Maintain or Enhance Efficiency." *IEEE Transactions on Industry Applications*, January 1986. p. 126-132.  
Good overview of techniques used in a good motor repair shop to optimize reliability and efficiency.

- Darby, E. Steve. "Rewinding Motors For Efficiency." *EC&M*, November 1987. p. 30.  
Describes recommended rewind techniques for optimum efficiency (and reliability) based on rewinding experience.
- Dreisilker, Henry. "Modern Rewinding Methods Assure Better Rebuilt Motors." *EC&M*, August 1987. p. 30.  
Describes efficiency benefits of mechanical winding removal at below 300F, rather than burn-out; also trickle varnishing.
- "Electric Motor Breakdown Warning." *Engineering Digest*, October 1988. p. 49.  
Describes device that detects changes in motor magnetic signature to indicate problems.
- Gupta, B.K. and D.K. Sharma. "Degradation of Turn Insulation in Motor Coils Under Repetitive Surges." *IEEE Transactions on Industry Applications*, June 1990. p. 320-326.  
Tests the hypothesis that electrical surges (such as produced by utility switch gear) ages winding insulation. Tests indicate minimal effect. Very technical.
- "How to Get the Most From Your Electric Motors." *EASA*, 1992.  
Guidelines on application, maintenance, cleaning, and testing of motors. Includes information on repair vs. replacement.
- Idhammar, Christer. "Basic Motor Cleaning, Inspection Can Help Reveal Possible Problems." *Pulp & Paper*, February 1994. p. 68.
- IEEE Standards Board. *IEEE Recommended Practice for the Repair and Rewinding of Motors for the Petroleum and Chemical Industry*. May 1990. IEEE STD 1068-1990. p. 23.  
Specific step by step technical instructions for repairing motors, as recommended for the petroleum and chemical industries.
- Jenkins, Sr., J.E. "How to Perform Electrical Maintenance on Induction Motors." *EASA Currents*, July 1990. p. 3.  
Guidelines on in situ maintenance and testing of induction motors.
- Keithly, Walter and Samuel Axe. "Unique Solution to Improving Motor Winding Life in Medium Voltage Motors." *IEEE Transactions on Industry Applications*, May/June-1984. Vol. IA-20, No. 3. p. 514-518.  
Describes heating technique to prevent moisture build-up in intermittently operating, medium voltage (over 1,000 volts) motors.
- Kryter, R.C. and H.D. Haynes. "How to Monitor Motor Driven Machinery by Analyzing Motor Current." *Power Engineering*, October 1989. p. 35.  
Describes technique that allows data for predictive maintenance to be obtained from the power supply of operating motors.
- Lawrie, R.J. "How Modern Service Firms Keep Your Motors Running Better and Longer." *EC&M*, July 1992. p. 39-48.  
Description of standard and innovative motor repair and testing procedures, featuring several progressive shops throughout the U.S.
- Lawrie, R. J. "Modern Motor Test Techniques." *EC&M*, July 1992. p. 33-38.  
Description of important motor testing techniques for trouble shooting and verification of proper repair.
- LeFevre, Rick. "Predictive Maintenance Surge Testing." *Plant Engineering*, June 1987. p. 103-107.  
In depth description of "Surge Testing," with specific testing program recommendations.



- Lotfi, Ashraf W., and Fred C. Lee. "A High Frequency Model for Litz Wire for Switch-Mode Magnetics." *Conference Record of the IEEE Industry Applications Society Annual Meeting 1993*, Vol. 2. p. 1169-1175.  
Discussion of insulated stranding magnet wire for applications involving high frequencies such as PWM drives. It has been suggested that this wire could reduce copper losses in rewound motors fed by inverters.
- Maassen, Erik. "Maintenance Tips for Electric Motor Bearings." *Maintenance Technology*, November 1992. p. 26-59.  
Discussion of motor bearing maintenance for optimizing reliability.
- McCoy, Gilbert, Johnny Douglass and Todd Litman. *Energy Efficient Electric Motor Selection Handbook, 3d Ed.* USDOE/BPA, January 1993. p. 51.  
Summary of considerations for selecting energy efficient motors for specific applications.
- Montgomery, David. "Testing Rewinds to Avoid Motor Efficiency Degradation." *Energy Engineering*, V. 86 N. 3 1989. p. 24-40.  
Overview of impacts of rewinds on motor efficiency.
- Montgomery, David. "The Motor Rewind Issue - A New Look." *IEEE Transactions on Industry Applications*, September 1984. p. 1330-1335.  
Good overview of impacts of rewinds on motor efficiency. Also disputes that motors lose efficiency merely because of aging.
- "Motor Winding Analyzer Detects Problems Early." *Power Engineering*, December 1991. p. 45.  
Describes use of a motor winding analyzer to predict and prevent insulation problems before they occur.
- Nailen, Richard L. *Electrical Apparatus*, November 1994.  
This journal of electromechanical and electronic applications and maintenance offers extensive reporting on electric motor repair in every issue.
- Nailen, Richard L. "Explosion-proof Motors Need Careful Repairs." *EC&M*, April 1986. p. 30 & 36.  
Discusses specific repair requirements for explosion proof motors.
- Nailen, Richard L. "Managing Motors." *Barks Publications, Inc.*, January 1991.  
This book provides very thorough coverage of electric motor design, efficiency, application, maintenance, and repair.
- Nailen, Richard L. "Motor Insulation Resistance Varies with Temperature." *Power*, October 1984. p. 142.  
Describes dramatic temperature adjustment needed for motor insulation resistance test.
- Nailen, Richard. "A User's View of Motor Repair Standards and Specifications." *IEEE Transactions on Industry Applications*, November 1988. p. 1131-1137.  
Author describes his program to establish motor repair standards.
- Nicholas, Jack. "Evaluating Motor Circuits." *Maintenance Technology*, November 1992. p. 30-34.  
Advice for evaluating motor circuits to maximize reliability.
- "Preventative Maintenance of Motors and Controls." *EC&M*, February 1986. p. 24 - 28.  
Outlines recommended motor and motor control maintenance program.
- "Proper Burnout Methods Maintain Efficiency of Rebuilt Motors." *EC&M*, March 1985. p. 71.  
Report on study by EASA on impact of stator winding burn out temperature on motor efficiency.

- Protopapas, C.A., S.D. Kaminaris, and A.V. Machias. "An Expert System for Fault Repairing and Maintenance of Electric Machines." *IEEE Transactions on Energy Conversion*, March 1990. p. 79-83.  
Description of software that can guide troubleshooting and repair of motors and generators.
- Ramsey, Milton H., and J. Kirk Armintor. "Recommended Practice for Repair of Electrical Motors." *IEEE Transactions on Industry Applications*, January-February 1993. p. 52-59.
- Reason, John. "Cut the Cost of Cleaning Electric Machines." *Electrical World*, April 1989. p. 74.  
Describes predictive testing for large (power plant) motors.
- Reason, John. "How and When to Grease Motors." *Power*, May 1984. p. 154.  
Recommendations for motor regreasing.
- Rewound Motor Efficiency; Technology Profile.** Ontario Hydro, November 1991. p. 3.  
Fact sheet discussing efficiency of rewound motors, and arguing for replacement of failed motors whenever possible.
- Schump, David E. "Motor Insulation Predictive Maintenance Testing." *Plant Engineering*, January 1991. p. 47-49.  
Description of insulation tests: insulation resistance test; dielectric absorption test; DC high-potential test, power factor test; and surge comparison test.
- Steel Products Manual.** American Iron and Steel Institute, January 1983.  
Electrical Steels: Description of core plate lamination insulation used in motors and transformers.
- Stone, G.C., Sedding, H.G., and B.A. Lloyd. "The Ability of Diagnostic Tests to Estimate the Remaining Life of Stator Insulation." *IEEE Transactions on Energy Conversion*, December 1988. Vol. 3 No. 4. p. 833-841  
Results of various testing methods to predict motor/generator failure. Pertains to very large machines.
- Strugar, Don and Ray Weiss. "Why Electric Motors Fail." *Plant Engineering*, July 1994. p. 65-66.  
Good description of the ambient conditions, and power system problems that often shorten the life of motors.
- Ula, Sadrul, Birbaum, Larry and Don Jordan. *Energy Efficient Drivepower; An Overview, & 3 Literature Reference Lists.* USDOE, WAPA & BPA. p. 41.  
Summary of motor system efficiency, with a short section on rewinds, and three large bibliographies.
- "Understanding Insulation Resistance Testing." *EC&M*, July 1984. p. 46-50.  
Describes three tests used to identify problems in motor insulation resistance.
- "Vibration Monitoring Prolongs Electric Motor Life." *Maintenance Technology*, November 1992. p. 51-54.  
Description of successful use of vibration monitoring on electric motors to anticipate problems for correction before failure.
- Weiss, Raymond H. "Selecting and Specifying a Large A-C Motor Rewind System." *Conference Record of Annual Pulp and Paper Industry Technical Conference*, 1993. p. 161-164.  
An excellent description of various insulating specifications for large motors exposed to environmental stresses.
- Zeller, Edward. "Motor Efficiency is Not Hurt By Careful Rewinds." *Power*, October 1984. p. 142 - 143.  
Summary of EPRI study of motor rewind efficiency and burnout temperature.

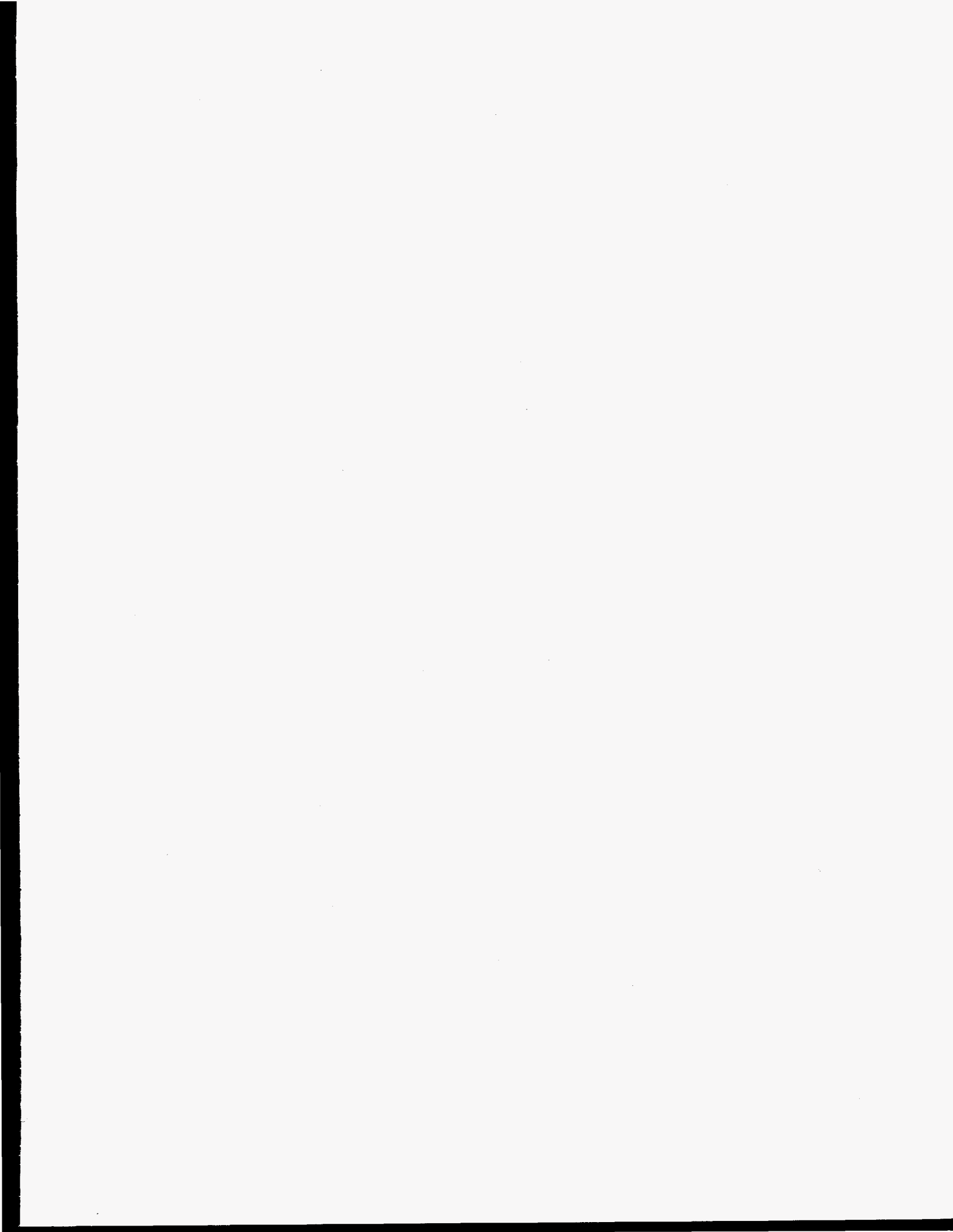

**BONNEVILLE**  
POWER ADMINISTRATION



PO Box 3621  
Portland, OR 97208-3621  
(503)230-5000

DOE/BP-2747 NOVEMBER 1995 1M

