

Department
of Energy



Arms Control and Nonproliferation Technologies

Office of Nonproliferation
and National Security

Third Quarter 1995

Developing Effluent Analysis Technologies to Support Nonproliferation Initiatives

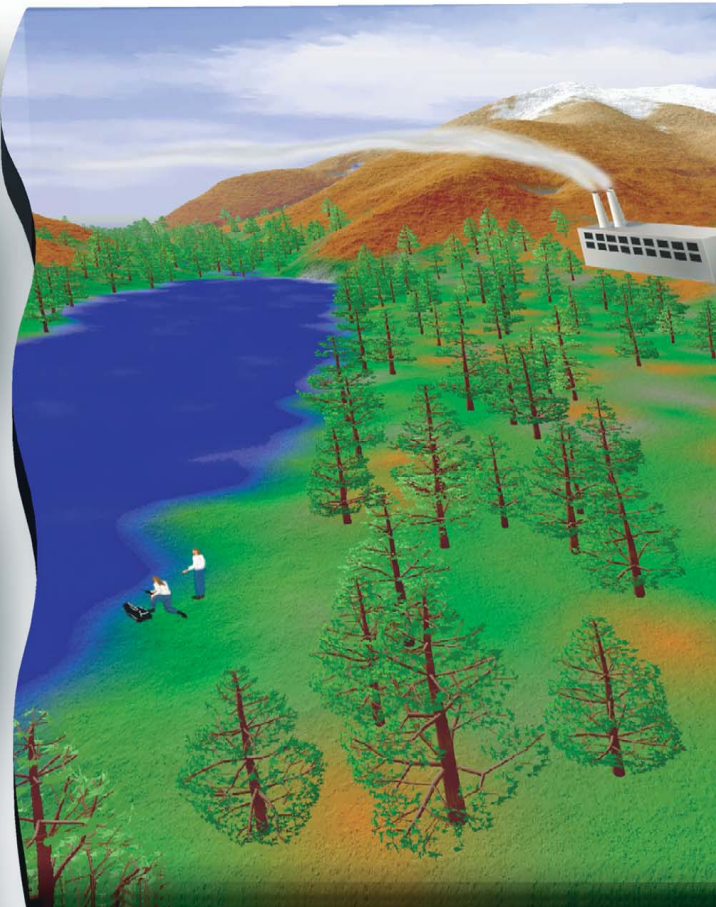
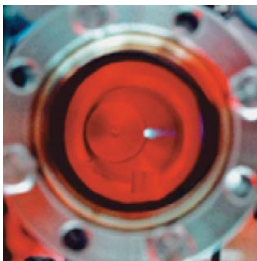
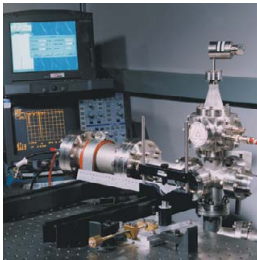



About the cover

This issue of ACNT focuses on several technology-development projects under the Effluent Research Program, sponsored by the Office of Nonproliferation and National Security, DOE. Research efforts are aimed toward more sensitive and portable instruments for the field and faster, more accurate analysis methods and equipment for the laboratory.



The purpose of Arms Control and Nonproliferation Technologies is to enhance communication between the technologists in the DOE community who develop means to verify compliance with agreements and the policy makers who negotiate agreements.



Published by

U.S. Department of Energy, Office of
Nonproliferation and National Security
Joan Rohlfling, Director

DOE/ACNT Project Manager

Michael F. O'Connell

Issue Editor

Steven A. Schubert

Scientific Editor

George Staehle

General Editor

Gorgiana M. Alonzo

Art/Design

Kirk Hadley, Lead Designer
Nancy Compton
Danial Fletcher
Dwight Jennings
Leonard Walton

Production Office

Arms Control and Nonproliferation Technologies
Lawrence Livermore National Laboratory
7000 East Ave. (L-389)
Livermore, CA 94550

Correspondence

George Staehle or
Gorgiana M. Alonzo

Phone

(510) 424-6100

Fax

(510) 423-9091

E-mail

acnt@llnl.gov

Disclaimer:

Reproduction of this document requires the written consent of the originator, his/her successor, or higher authority. This report was prepared as an account of work sponsored by the United States Government. Neither the United States Government nor the United States Department of Energy nor any of their employees makes any warranty, express or implied, or assumes any legal liability or responsibility for the accuracy, completeness, or usefulness of any information, apparatus, product, or process disclosed, or represents that its use would not infringe privately owned rights. Reference herein to any specific commercial product, process, or service by trade name, trademark, manufacturer, or otherwise, does not necessarily constitute or imply its endorsement, recommendation, or favoring by the United States Government. The views and opinions of authors expressed herein do not necessarily state or reflect those of the United States Government and shall not be used for advertising or product endorsement purposes.

Contents

Page

Introduction—Developing effluent analysis technologies to support nonproliferation initiatives	2-7
Section 1—Portable instruments for on-site inspections	8-19
Section 2—Standoff detectors	20-25
Section 3—Fieldable, real-time instruments	26-31
Section 4—Field collection techniques	32-39
Section 5—Ultrasensitive laboratory techniques ...	40-57
Distribution	58-60

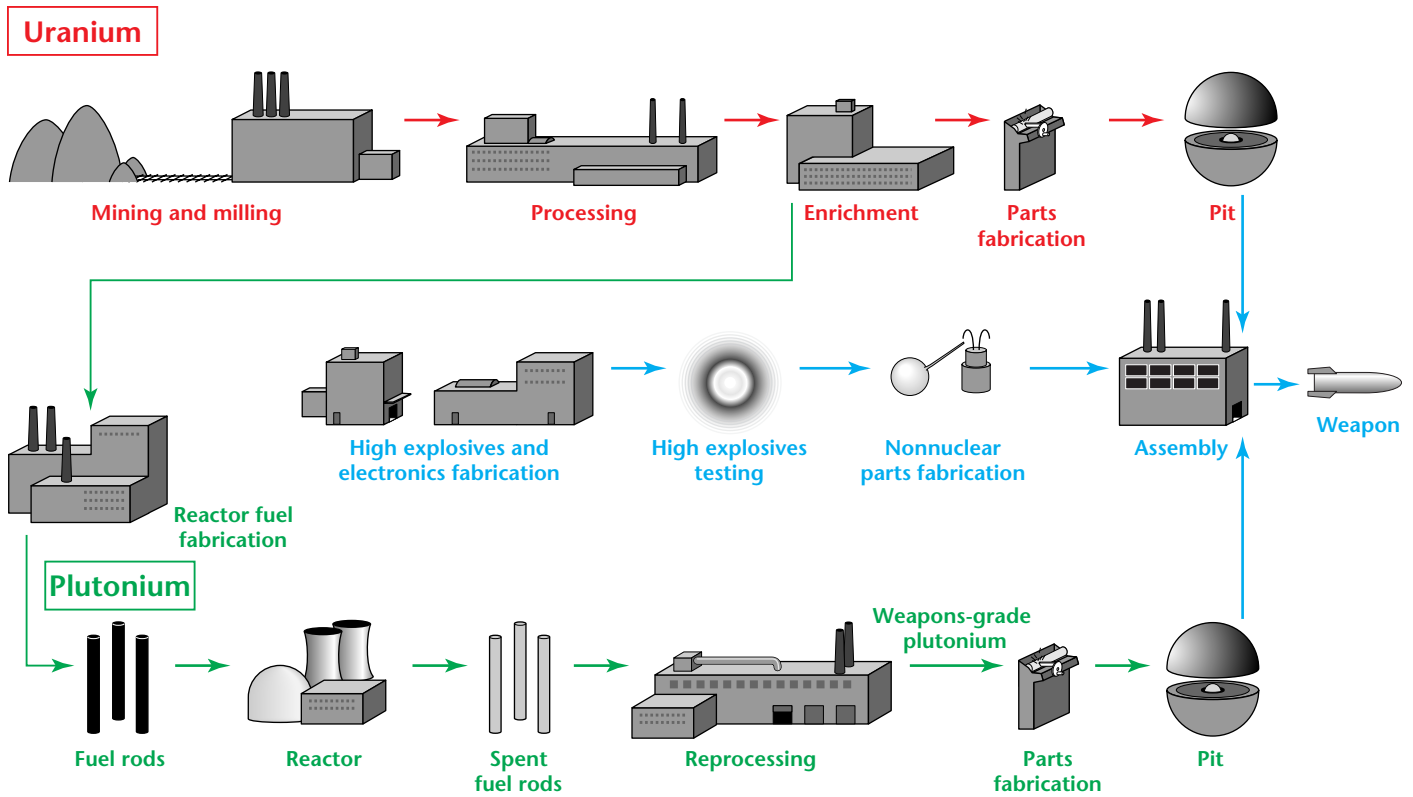

Developing effluent analysis technologies to support nonproliferation initiatives

This issue of *Arms Control and Nonproliferation Technologies* provides an overview of the Effluent Research Program of the Department of Energy’s (DOE) Office of Research and Development, highlighting a number of representative projects within this program.

The Office of Research and Development uses the nuclear R&D expertise residing within the DOE’s national laboratory system to address current and potential national security issues. Today these issues include formulating *measurable* test ban treaties, stemming nuclear proliferation, combatting nuclear smuggling, and generally ensuring nuclear materials control throughout the weapons’ life cycle, as depicted above.

The Effluent Research Program focuses on these critical national security

issues and develops appropriate technical solutions to the problems they present. Research projects center on specific goals pertaining to detecting chemical and physical signatures.

Customers and Applications

The primary national security customers for the technology products of the Effluent Research Program include those domestic and international agencies responsible for negotiating and verifying arms control treaties: the On-Site Verification Agency, the International Atomic Energy Agency, the Arms Control and Disarmament Agency, and the Department of State. In addition, agencies that monitor compliance with arms control treaties—such as the Arms Control Intelligence Staff, the Central Intelligence Agency, and the Defense

Above picture: Nuclear weapon production pathways.

Intelligence Agency—also benefit from the Effluent Research Program.

Technology products developed to support these customers have applications in a number of secondary areas. Detection, identification, and characterization of nuclear elements are of interest to agencies involved in environmental monitoring and restoration and waste management (for example, the Environmental Protection Agency, U.S. industry, the DOE and its facilities, and Department of Defense (DoD) facilities). Effluent research also supports the DoD's Counterproliferation Initiative by enhancing the DoD's ability to detect, identify, and characterize nuclear hazards.

Law enforcement agencies represent another customer base because the Effluent Research Program's technology products have applications in nuclear and drug interdiction and in forensic investigations of incidents and accidents. Emergency response organizations, such as the DOE's Nuclear Emergency Search Team, the Federal Emergency Management Agency, military Special Operations Forces, and fire and rescue agencies, can also use technology products developed by the program.

Technology Trends

The Effluent Research Program reflects the impact of several trends in technology development. These trends include—
Increased reliance on mass spectrometry. Traditional radiation detection instruments rely on counting technologies. Over the past two decades, mass spectrometers have gradually supplanted counting as the method of choice in the detection of radioactive isotopes. The variety of mass spectrometers available today provides the means to meet most requirements for sensitivity and selectivity, from small, hand-held devices to large, laboratory-based instruments. A notable exception is Comprehensive Test Ban Treaty (CTBT) verification where counting is still preferred for detecting short-lived radionuclides.

Increasing sensitivity and selectivity.

Increased sensitivity permits detection of smaller concentrations of materials and also detection at greater ranges than has been possible. Increased selectivity provides improved capabilities to detect trace amounts in the presence of similar or interfering chemicals.

Miniaturization. The miniaturization trend evident in electronics is also evident in effluent research. Smaller sample volumes, reduced instrument size and weight, and lower power consumption have resulted in improved portability (and sometimes lower cost). Miniaturization is a key ingredient in the migration of what were once laboratory-based technologies into technologies that can be taken into the field and, in some cases, hand-carried.

Real-time response. Policy makers' demands for rapid response have drawn more attention to real-time or near-real-time (24 hours or less) collection and analysis. Research has focused on achieving a reasonable balance between field and laboratory analyses and the attendant tradeoffs with regard to sensitivity and selectivity (generally lower in the field) and turnaround time (longer for laboratory-based analyses).

Improved field collection. The push for real-time results has spurred the development of better field-collection systems and techniques. This research has produced more efficient and "user-friendly" collection systems.

Technology combinations. There is a growing trend toward combining technologies to achieve broader or enhanced detection capabilities through synergism.

Automation. Automation represents another trend that has decreased response time. In addition, it provides increased productivity, lower cost, and unattended remote operation.

Standoff detection. Improvements in remote spectroscopic techniques have contributed to standoff detection at increasing ranges.

Program Goals

The Effluent Research Program has established five goals designed to leverage technology trends and meet customer needs:

1. Develop easy-to-use, portable instruments for on-site inspections;
2. Develop standoff detectors with increased range;
3. Develop fieldable, real-time instruments for ground- and air-based applications;
4. Develop improved field-collection techniques;
5. Develop ultrasensitive laboratory techniques and instruments, incorporating automation, increased sensitivity and selectivity, and greater reliability.

Summary

The table (pages 5–7) provides a convenient means of cross-referencing the many Effluent Research projects to the stated goals. It also serves as a road map to the articles in this issue. It was not our intent to cover every project in a single issue of *Arms Control and Nonproliferation Technologies*, but rather to represent a broad cross-section. Space considerations limited the number of articles presented and their depth, however, additional information can be obtained by contacting the Office of Research and Development at DOE. ☼

CONTACT: **Steve Schubert**
DOE/Office of Research and Development
PHONE: 202-586-9721
FAX: 202-586-0485
EMAIL: sa_schubert@pnl.gov

Title (Project number)	Contact name and laboratory	Brief description	Chemical species	Sample media	Sensitivity	Pages
Section 1—Portable instruments for on-site inspections						
Hand-Held Optical Spectrometer (ST489DC)	Nick Nogar LANL	Survey chemical composition and identify key signature species	Metallic elements	Solids	pph	8–9
Portable Proliferation Sensing System (AL012)	Steve Dieckman ANL	Develop a portable chemical and isotopic analyzer for air monitoring	Various species	Air, solids	ppb	10–11
Laser-Induced Fluorescence for Uranium Isotopic Assays in the Field (ST489HA)	Norm Anheier PNNL	Assay uranium isotopic composition in real time from field samples	Uranium isotopics	Solids	ppm	12–13
Miniature Mass Spectrometer (ST541)	Dan Dietrich LLNL	Develop a portable chemical and isotopic analyzer for air monitoring	Volatile species	Air	ppb	14–15
Photoacoustic Spectrometer to Identify Small Samples (ST597)	Peter Vanier BNL	Characterize microgram samples of solids or liquids and identify key signature species	Various species	Solids, liquids	pph	16–17
Very Small Gas Chromatography-Mass Spectrometry Instrument (ST240)	Brian Andresen LLNL	Develop a highly sensitive gas-chromatograph-mass spectrometer weighing no more than 132 kg	Volatile organics	Air	ppm	18–19
Glow Discharge Instrument for Uranium Isotopics (ST489GA)	Bob Shaw ORNL	Assay uranium isotopic composition in real time from field samples	Uranium isotopics	Solids	ppm	
Portable Standoff Atomic Analysis (ST489DD)	Jim Blacic LANL	Identify chemical composition of solids at standoff distances (~10–100 m)	Various species	Solids	pph	
Section 2—Standoff detectors						
Detecting Airborne Chemicals by an AOTF Spectrometer (SR003)	Eliel Villa SRTC	Detect airborne key signature species by passive, long-wave infrared spectrometry using an acoustic-optic, tunable filter	Organic/inorganic volatiles	Air	ppb	20–21
Millimeter-Wave Detection of Airborne Chemicals (ST214)	Sami Gopalsami ANL	Detect airborne key signature species using millimeter-wave spectrometry	Organic/inorganic volatiles	Air	ppb	22–23
Remote Infrared Chemical Sensing (ST740)	Chuck Stevens LLNL	Detect airborne key signature species using mid-range infrared spectrometry	Organic/inorganic volatiles	Air	ppb	24–25

Continued on next page ...

Legend

Affiliations

ANL = Argonne National Laboratory
 BNL = Brookhaven National Laboratory
 INEL = Idaho National Engineering Laboratory
 LANL = Los Alamos National Laboratory
 LBNL = Lawrence Berkeley National Laboratory
 LLNL = Lawrence Livermore National Laboratory
 ORNL = Oak Ridge National Laboratory
 PNNL = Pacific Northwest National Laboratory
 SNL = Sandia National Laboratories
 SRTC = Savannah River Technology Center

Sensitivity

pph = parts per hundred
 ppm = parts per million
 ppb = parts per billion
 ppt = parts per trillion
 ppq = parts per quadrillion
 ppqq = parts per quintillion

Title (Project number)	Contact name and laboratory	Brief description	Chemical species	Sample media	Sensitivity	Pages
Section 3—Fieldable, real-time instruments						
Real-Time Analyzer for Airborne Chemicals (ST447)	Bob Wright PNNL	Develop air analyzer for volatile organic species	Volatile organics	Air	ppt	26-27
Real-Time Monitoring of Volatile Compounds: Ion Store/Time-of-Flight Mass Spectrometer (ST610)	Dave Chambers LLNL	Develop advanced real-time air analyzer	Volatile organics	Air	ppt	28-29
Xenon Radionuclide In-Situ Analysis (ST583)	Ted Bowyer PNNL	Detect airborne Xe radioisotopes	Noble-gas radionuclides	Air	*	30-31
Perimeter Monitor for Volatile Organic Compounds (LA005)	Phil Hemberger LANL	Selectively detect ultratrace levels of organics in air in real time	Volatile organics	Air	ppt	
Real-Time Airborne Radionuclide Analyzer and Collector [RTARAC] (ST445)	John Smart PNNL	Develop air analyzer for radionuclides to be deployed in aircraft pod	Radionuclides	Airborne particles	*	
Real-Time Detection of ¹²⁹ I (ST579)	Dave Koppenaal PNNL	Develop real-time, ground-based monitor for ¹²⁹ I	¹²⁹ I	Air	ppt	
Section 4—Field collection techniques						
CAPS—Chemical Analysis of Proliferation Signatures (LL011)	Brian Andresen LLNL	Develop improved methods of field collection and laboratory analysis	Various species	Various media	*	32-33
Particle Collection with an Electrostatic Precipitator (ST620)	Cliff Carlson SRTC	Develop a simple, improved method of collecting airborne particles for lab analysis		Airborne particles		34-35
Real-Time Detection of Short-Lived Fission Products (ST271)	Harry Miley PNNL	Automatically detect short-lived radionuclides by gamma counting	Radionuclides	Particles in air	*	36-37
Ultratrace-Level, Organic Chemical Analysis (ST217)	Bob Wright PNNL	Couple large-volume air sampling with highly selective, trace organic analysis	Volatile, semi-volatile organics	Air	ppt	38-39
Direct Analysis of Environment Samples by Selective Sorbents and Laser Desorption (LA012)	Phil Hemberger LANL	Improve field collection and sample introduction methods	Inorganics, non-volatile organics	Air, water	ppt	

Continued on next page ...

Title (Project number)	Contact name and laboratory	Brief description	Chemical species	Sample media	Sensitivity	Pages
Section 5—Fieldable, real-time instruments						
Automated Nuclear Track Characterization (PL006)	Brion Burghard PNNL	Reduce the time required to analyze environmental samples	Fissionable materials	Solids		40–41
Ion Trap Inductively Coupled Plasma Mass Spectrometer [IT-ICP/MS] (ST392)	Dave Koppenaal PNNL	Rapidly analyze ultratrace levels of actinide elements and compounds	Actinide isotopes	Solids	ppt	42–43
Nondestructive Determination of Particulate Composition (ST801B)	Arlyn Antolak SNL	Reduce the time required to analyze environmental samples	Elements	Solids	ppb	44–45
Particle Separations by Capillary Electrophoresis (ST381)	Nate Ballou PNNL	Reduce the time required to analyze environmental samples	Actinides, heavy metals	Particles		46–47
Photon-Burst Mass Spectrometry (ST104)	Nick Nogar LANL	Develop detection method for isotopic analysis of noble gases	Noble-gas isotopes	Air		48–49
Radiofrequency Glow Discharge/Fourier Transform/Ion Cyclotron Resonance Mass Spectrometer (ST825)	Bob Weller SRTC	Develop a mass spectrometer to analyze insulating materials (glasses and ceramics)	Elements, isotopes	Particles, insulating solids	ppm	50–51
Thermal Emission Ion Source for Accelerator Mass Spectrometry [TEAMS] (ST224)	Paul Reeder PNNL	Reduce sample size to milligrams for accelerator mass spectrometry	¹²⁹ I	Solids	ppq	52–53
Trace Detection on Surfaces by Secondary Ion Mass Spectrometry (ILO32)	Tony Appelhans INEL	Analyze sample surfaces for ultratrace levels of chemicals with minimal sample preparation	Inorganics, non-volatile organics	Solid surfaces	*	54–55
Ultratrace Techniques: Radioisotope Analysis with Accelerator Mass Spectrometry (ST801A)	Ivan Proctor LLNL	Detect ultratrace levels of halogens	Halogens	Solids	ppq	56–57
Advanced ITMS R&D (OR116)	Scott McLuckey ORNL	Simplify operation of and improve analysis capabilities of ion trap mass spectrometers				
Analysis of Ultrasmall Air Samples for Stable Noble Gases (ST618)	Jane Poths LANL	Analyze stable noble-gas isotopes with a one-part-in-0.1-million precision	Stable noble-gas isotopes	Air	ppt	
Chemical Analysis by Bubble Chamber Spectroscopy (ST614)	Bob Sander LANL	Investigate ultrasensitive detection method for compounds in solution	Organics, inorganics	Water or solution	ppt	
Fluorescence Detection of Single Atoms or Molecules in Water (OR115)	Bill Whitten ORNL	Detect ultrasensitive levels of selected signature species in water	Fluorescent materials	Water	ppqq	
Laser and Radioactivity Capillary Electrophoresis [LARCE] (LL004)	Rick Russo LBNL	Improve methods for preconcentrating selected ions in aqueous solutions and develop on-line radiochemical analyses	Anions, cations	Aqueous solutions	ppt	
Microchip Liquid Phase Analysis (ST790)	Mike Ramsey ORNL	Develop microminiaturized instrumentation to reduce size and cost of analysis	Organics, inorganics	Water or solution	ppt	
Real-Time Analysis of Airborne Particles (OR148)	Bill Whitten ORNL	Develop real-time particle analyzer	Sorbed organics, bulk inorganics	Particles	ppt	

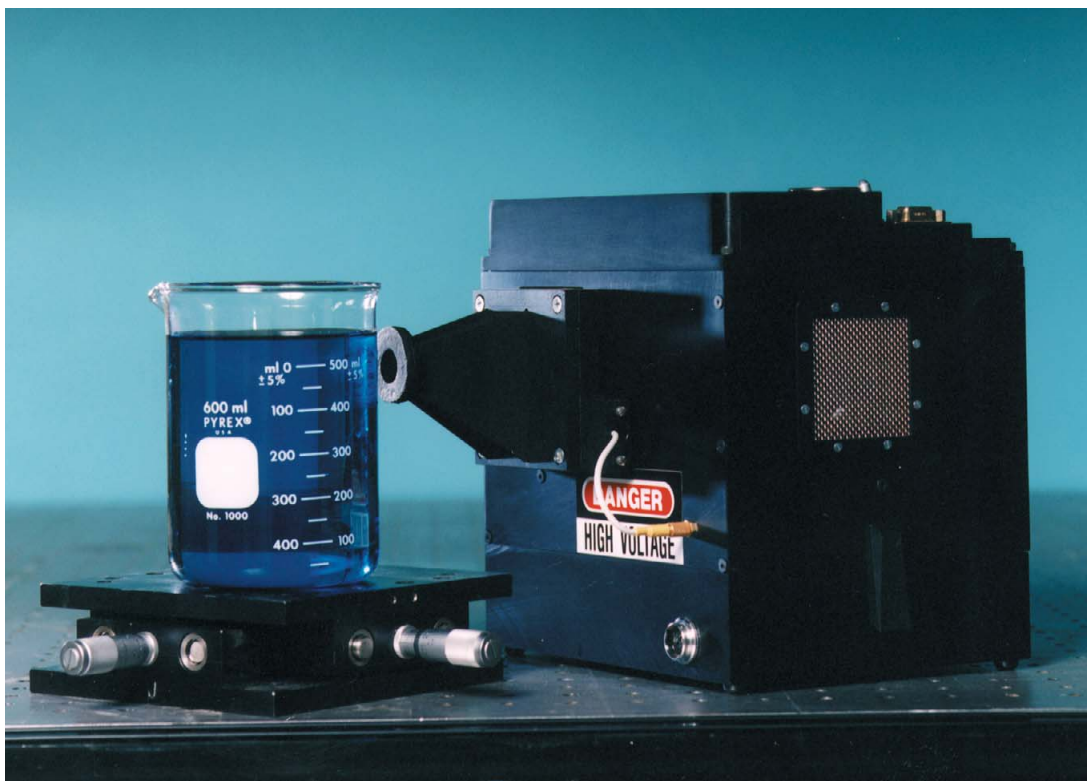

Hand-Held Optical Spectrometer (ST489DC)

The majority of chemical analyses require that samples be brought to a central laboratory with specialized chemical instrumentation. This can result in several sub-optimal outcomes, depending on the circumstances. Delays between sampling and the generation of results typically limit the number of samples analyzed. Delays may affect the outcome of operations related to the analyses; in field surveys, the ordering and location of subsequent samples may depend on the outcome of previous analyses. In process monitoring, delays in obtaining analytical results can severely undermine the performance and profitability of a particular process. In clinical applications, the health or even the life of a person may depend on rapid chemical analysis. Lastly, the act of sampling and sending samples to a central laboratory can contaminate or degrade the samples, thus altering the very system being measured. Field instruments clearly serve a

variety of needs in chemical analyses.

Our hand-held optical spectrometer is self-contained and battery-operated. This unit has an on-board optical excitation source, a miniaturized monochromator, a CCD detector, a Peltier cooler, an LCD display module, and microprocessor control. All power and data-acquisition electronics are also on-board. The optical spectrometer is intended for on-site inspections requiring qualitative or semi-quantitative analyses.

The optical spectrometer can measure fluorescence and absorption semi-quantitatively. The optical spectrometer was characterized with a number of fluorescent and absorbing samples. The measured resolving power of this instrument is $1/\Delta \approx 1200$, where Δ is measured at the $1/e$ intensity points on the line. The resolution is superior to most portable, commercial UV/Visible spectroscopy units, including several recently available monolithic units.

Above photo: The Hand-Held Optical Spectrometer can quantify absorbing materials.

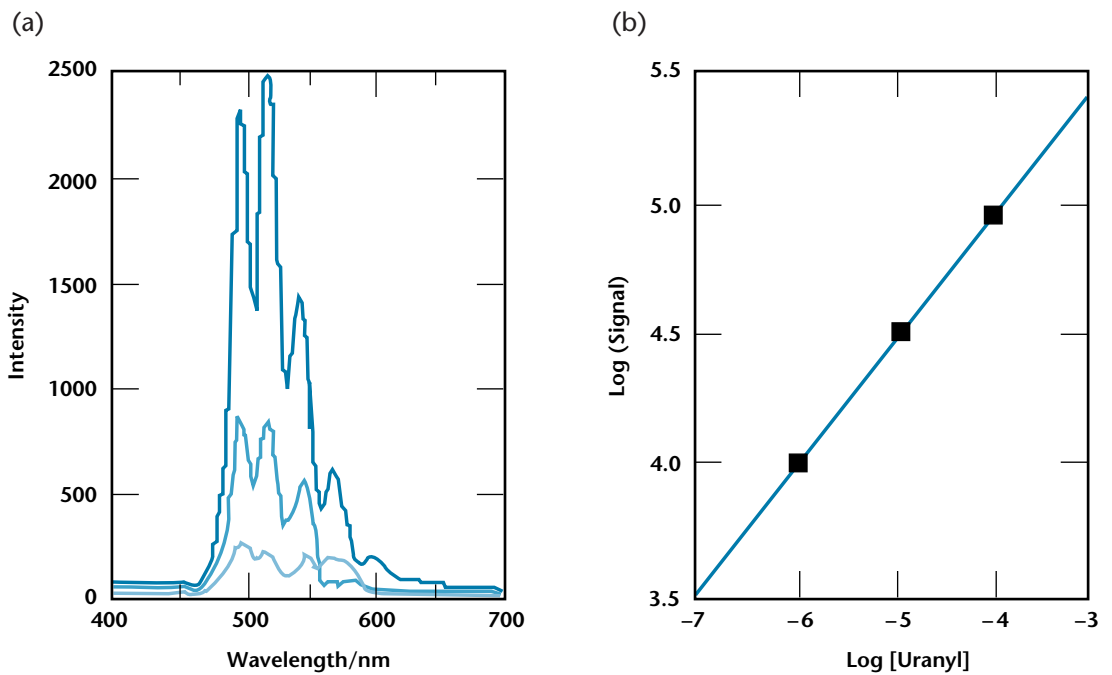

Figure 1. (a) shows excitation spectra for 10^{-4} , 10^{-5} , and 10^{-6} M solutions of uranyl nitrate, while (b) shows a calibration curve based on this data.

In addition, the dynamic range of measurement possible is excellent: greater than three orders of magnitude.

Uranium is a common nuclear material for which routine monitoring may be necessary. Figure 1 shows this instrument applied to a quantitative analysis problem. Figure 1(a) shows fluorescence spectra obtained from 10^{-4} , 10^{-5} , and 10^{-6} M solutions of uranyl nitrate. The spectrum contains peaks characteristic of uranyl fluorescence in solution. However, there is evidence—particularly for the lower concentration samples—that visible light from the mercury excitation source (546 and 577 nm) is passing through the excitation/detection filter train to the detector. Therefore, in assessing the quanti-

tative capabilities, only the signal from 450 to 525 nm is integrated as a measure of uranium fluorescence. Figure 1(b) shows a calibration curve generated from the spectra shown in Fig. 1(a). These data yield a straight line over the measured concentration range. ❁

CONTACT: **Nick Nogar**
 Los Alamos National Laboratory
 PHONE: 505-665-7279
 FAX: 505-665-4631
 EMAIL: nogar@lanl.gov

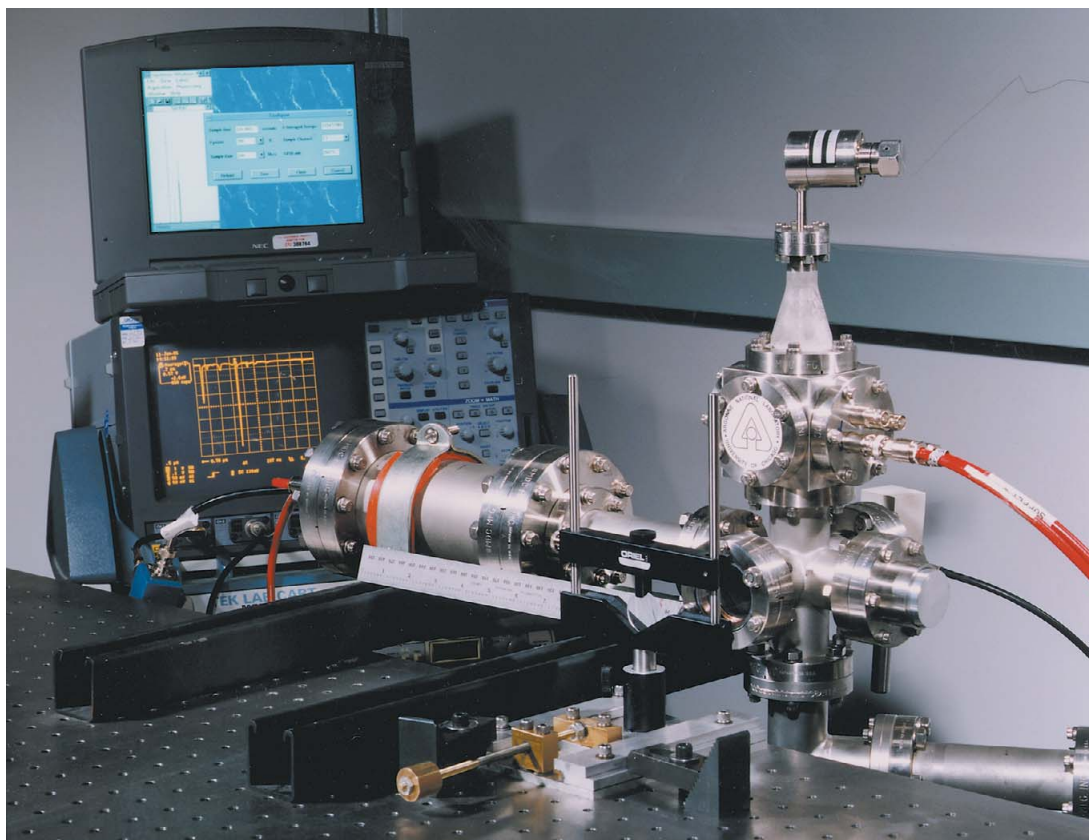

Portable Proliferation Sensing System (AL012)

Argonne National Laboratory is developing a portable sensing system to support nuclear nonproliferation and related activities in the field. This sensing system is based on pulsed-laser, photo-ionization, and time-of-flight mass spectrometry. The system quickly analyzes gas-phase molecules or any molecule induced into the gas phase. This system is portable, highly sensitive, and has a high performance-to-cost ratio. The system can be automated for on-site inspections and can be modified for other applications, such as perimeter monitoring aboard a plane or drone.

The complete spectrometer including the computer system is about the size of a notebook ($10 \times 23 \times 28$ cm) and weighs between 7-8 kg (Fig. 1). The spectrometer consists of a miniature laser, cryocooler, cold finger, vacuum pump, leak valve, ion detector, and an electrostatic ion lens.

Auxiliary components (not presented in Fig. 1 but included in the size and weight specifications) include the instrument control and data-acquisition electronics, a global positioning sensor (GPS), and the battery pack.

The technique of photo-ionization followed by time-of-flight mass spectrometry provides simplicity in instrument function and control. Gas-phase molecules are leaked into the spectrometer (maintained at high vacuum). The molecules collide with the cold finger (at liquid-nitrogen temperature) and freeze onto the surface. A short, ultraviolet laser pulse (3 ns) is then applied to the frozen molecules, causing ionized molecules to form near the surface. These ionized molecules (ions) are then accelerated by applying high voltages to the electrostatic ion lens. The ions are propelled away from the surface of the cold finger, fly down the flight tube,

Above photo: Laboratory prototype of the portable proliferation sensing system with the identical geometry and ion physics as in the field unit.

and ultimately collide with the ion detector. Because all the ions are accelerated with the same potential, low-mass ions travel quickly, while higher-mass ions travel more slowly. Data are then acquired as a function of time, providing a spectrum of the sample's molecular masses (commonly called a mass spectrum). Molecules of interest segregated by mass can be identified and quantified.

A notebook computer, requiring minimal operator training, controls the spectrometer system. User-friendly, mouse-driven software controls the instrument and automates data acquisition and processing. We are using a Windows-based, graphical programming language so that simplicity in design and programming is maintained along with the analytical and instrument control capabilities. Using this popular hardware platform means that upgrades will be effortless. Additionally, the software development package can be easily customized for specific users or applications. Pattern recognition for automated analysis of data through ion-fragment matching with a known database will soon be installed. Other software features will include accurate sample location using the GPS.

Results to date with the laboratory prototype demonstrate that high molecular resolution and sensitivity can be achieved with a miniaturized flight-tube geometry. Additionally, the system has demonstrated fast response as the entire mass range is acquired in approximately 10 μ s. For the portable system in which data averaging will be employed, accurate spectra of the sample may be available in less than 60 s.

In addition to its use in nonproliferation operations, the system is sufficiently robust to support the in-field sensing requirements of other government and civilian agencies. For example, the system can be modified to detect bombs in airports. Other applications of this technology include in-field drug sensing and identification and environmental contaminant detection and monitoring. The sensor system's portability and automation facilitate several deployment scenarios.

Inside view:

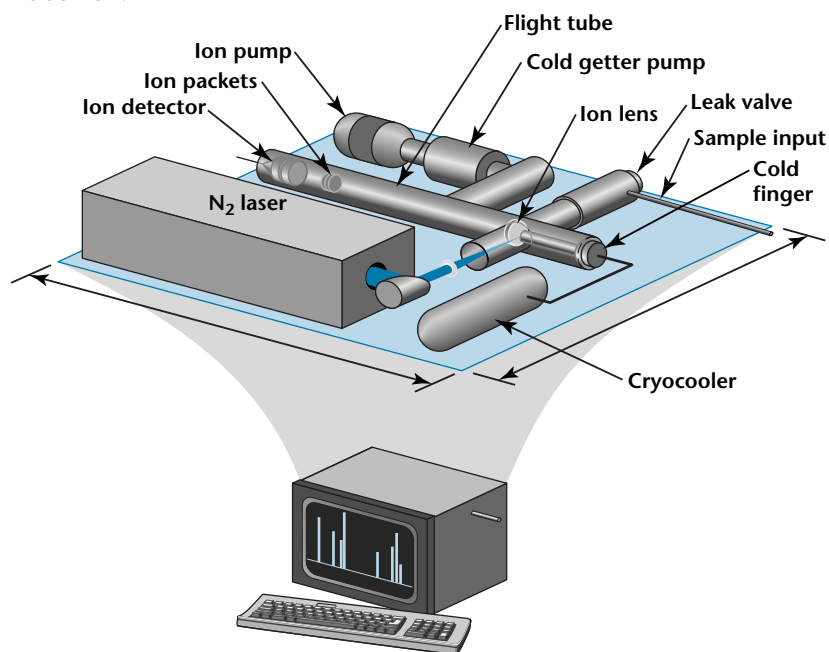
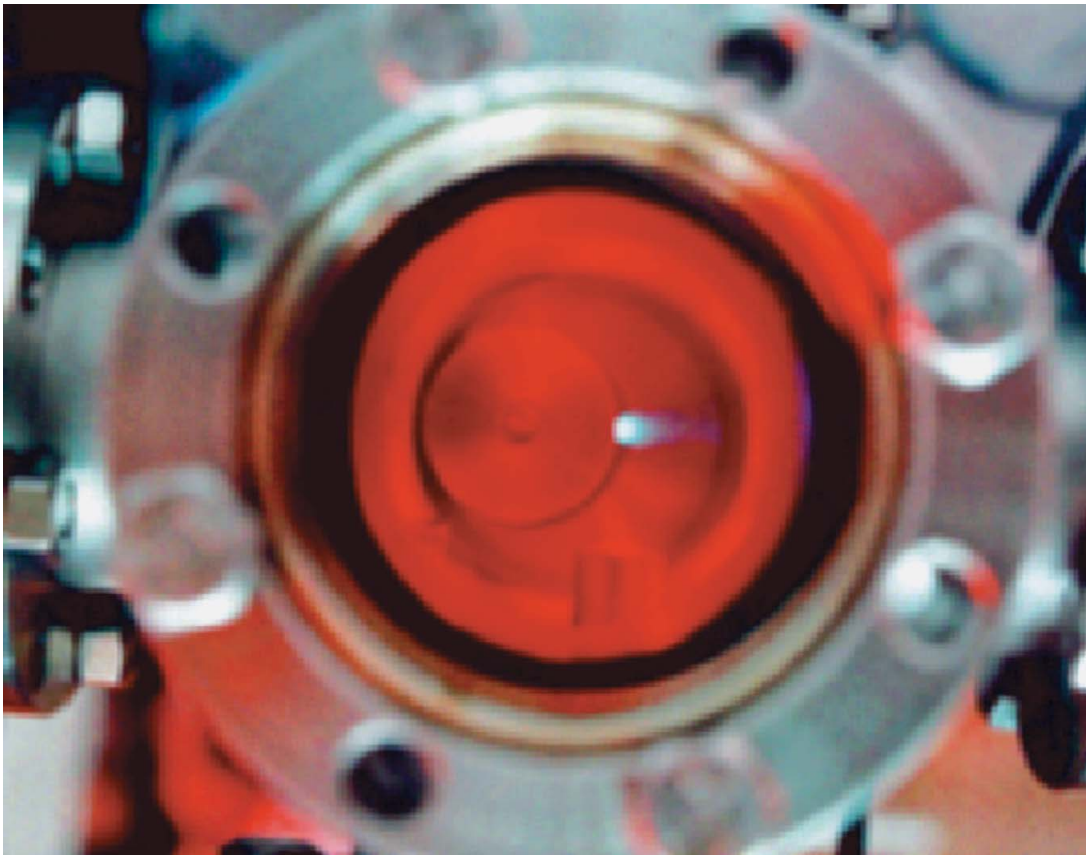

Figure 1. The portable proliferation sensing system has a time-of-flight mass spectrometer and weighs between 7–8 kg.

Additional advantages of this system include automated pattern recognition that gives the operator immediate feedback. Pattern analysis can signal the operator of impending danger, suggest additional in-field analyses, and recommend sampling of selected specimens for further laboratory analysis. Enhanced configurations of the system may include a laser desorption sampling system that can ablate molecules and atoms off solid surfaces with a high-intensity, infrared laser pulse. Ablated molecules would then be analyzed by leaking into the spectrometer chamber. ❁

CONTACT: **Steve Dieckman**
Argonne National Laboratory
PHONE: 708-252-5628
FAX: 708-252-3250
EMAIL: sl_dieckman@qmgate.anl.gov



Laser-Induced Fluorescence for Uranium Isotopic Assays in the Field (ST489HA)

Measuring uranium isotope ratios in samples can identify the presence of enriched uranium. These ratios are usually measured in analytical laboratories, requiring weeks or months before inspectors have the results. We are building a light-weight, portable instrument that determines the isotopic composition of uranium in samples as they are collected. The Laser Ablation, Laser-Induced Fluorescence (LALIF) system atomizes microscopic parts of samples by laser ablation and measures isotope ratios by laser-induced fluorescence. The LALIF system provides rapid feedback to inspectors looking for nuclear materials.

Housed in a ruggedized travel case (Fig. 1), the current LALIF system requires only power from a portable generator or a wall plug. The system works with any of the wall-plug standards throughout the world, and inspectors can operate it with

little training. Once the LALIF system is on site, it is ready to assay samples, such as dust or scrapings from a surface suspected of containing enriched uranium.

The LALIF system includes miniature lasers that prepare and measure the sample, a measurement chamber to hold and manipulate the sample, and sensitive optical detectors to measure the signal fluorescence. A computer system embedded in the instrument controls the system, logs data, and displays assay results.

Inspectors attach a sample with double-sided tape onto a mounting drum that is drawn into the measurement chamber. Inside the chamber, the sample is moved under the focused ablation laser beam. Light from a pulsed ultraviolet nitrogen laser ablates part of the sample and creates a plume of atomic vapor (Fig. 2). The plume for a sample containing uranium has atoms of all isotopes present in

Above photo: Uranium sample being ablated within the sample chamber of the Laser Ablation, Laser-Induced Fluorescence (LALIF) system.

LALIF components

- | | |
|----------------------------------|----------------------------|
| 1. Ablation laser | 11. Uranium vapor source |
| 2. Focusing optics | 12. Diode laser |
| 3. Mirror | 13. Beam splitter |
| 4. Lock-in amplifier | 14. Lens |
| 5. Diode current control box | 15. Fiber-optic positioner |
| 6. Sample ablation chamber | 16. Circuit boards |
| 7. Stepper motor and translator | 17. Fluorescence detector |
| 8. Stepper motor controller | 18. Getter |
| 9. Bifurcated fiber-optic bundle | 19. Circulating pump |
| 10. Translator controller | |

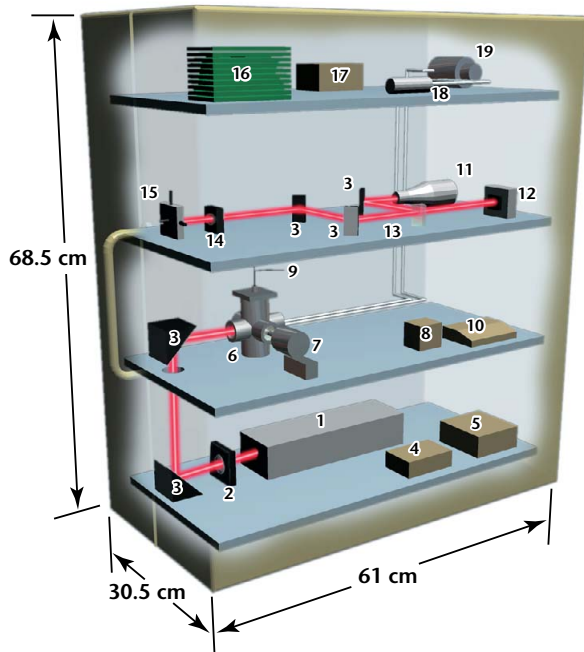

Figure 1. The LALIF system, shown in a suitcase, weighs less than 25 kg.

the sample at that location.

Light from a semiconductor diode laser with a wavelength near 682 nm excites any uranium atoms within this vapor plume. The diode laser light can be wavelength-tuned to selectively excite any desired isotope of uranium. The uranium atoms excited at the specified wavelength emit light at a longer wavelength, 713 nm, in a process called laser-induced fluorescence.

The fluorescence intensity is proportional to the concentration of the uranium isotope being excited. Ratios of the abundance of chosen uranium isotopes, usually ^{235}U and ^{238}U , are measured to determine if the sample has been artificially enriched. If any one of these ratios is greater than 0.73% (the value for natural uranium), enriched uranium is present.

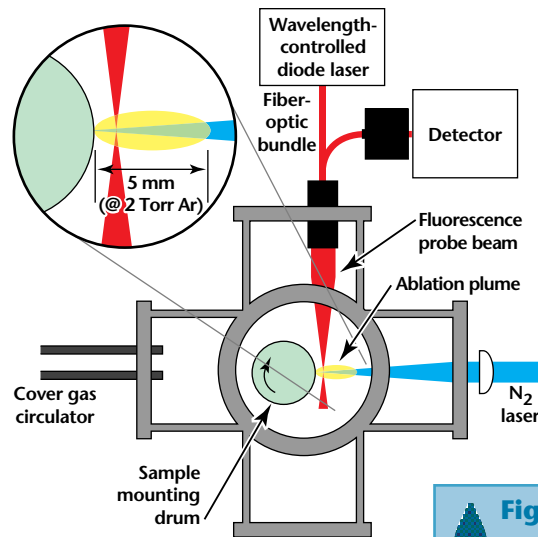
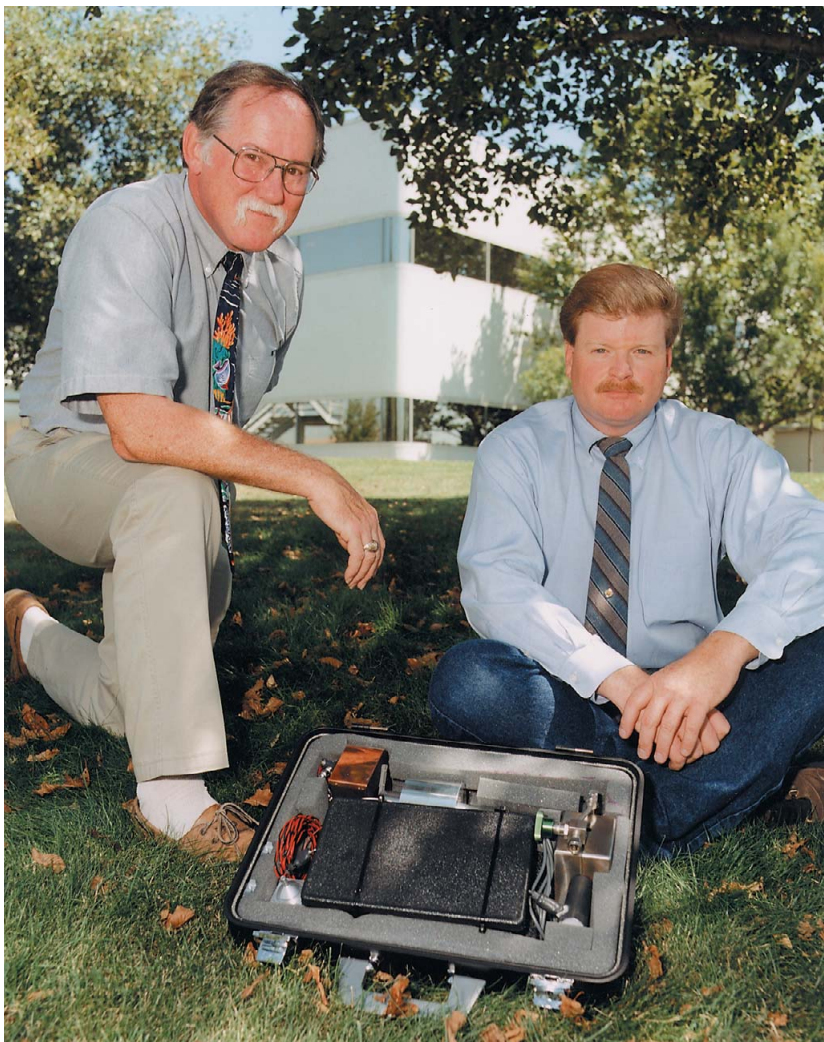

Figure 2. Cross-section of LALIF ablation chamber shows the area corresponding to number 6 in Fig. 1.

Within 10 minutes, 600 measurements can be made of a sample in the measurement chamber. A sample from a proliferation site likely includes a small fraction of particles containing enriched uranium mixed with particles containing natural and depleted uranium. The average uranium isotope ratio might not be significantly above that for natural uranium even though the sample might contain particles of highly enriched uranium. By making hundreds of measurements in different parts of each sample, the LALIF system can detect the most minute evidence of nuclear proliferation.

Rapid field measurements of uranium isotope ratios make it possible to identify two classes of nuclear weapons-grade material—enriched uranium and ^{233}U . Enriched uranium, produced by enriching the concentration of ^{235}U from the naturally occurring level of 0.73%, is considered weapons-grade at about 90%. ^{233}U is produced by neutron irradiation of thorium. The LALIF system can detect both types of enrichment activities by sampling for either of these isotopes. ❁

CONTACT: **Norm Anheier**
 Pacific Northwest National Laboratory
 PHONE: 509-375-2639
 FAX: 509-375-6736
 EMAIL: nc_anheier@pnl.gov



Miniature Mass Spectrometer (ST541)

a small briefcase. Its accuracy is 1 in 1,000 ($1:10^3$) and will ultimately be $1:10^4$ —a long way from the sensitivity of the large research units but sufficient for its planned uses.

Although this miniature mass spectrometer is still being developed, it could have greater sensitivity and efficiency than conventional laboratory-based, single-pass mass spectrometers. A single-pass unit has an ion source where the sampling material is ionized, an analyzer where the ions are separated in space according to their mass and velocity, and a detector that measures the electrical charge on the ions. Some loss of ions as they move from region to region within the unit is inevitable.

The miniature mass spectrometer, based on the Penning ion trap, eliminates transmission losses. Ions are created inside the trap, and analysis and detection are done there as well. Ions can be sampled many times. Our design adds one component from the basic research ion trap—an open-ended cylinder that fits inside superconducting magnets. In a cylindrical ion trap, the homogeneous magnetic field keeps the ions in a very narrow orbit in

Highly sensitive ion traps have been used to study individual particles for several years, with some ion traps having a mass accuracy of one part in one quintillion, or $1:10^{18}$. If the theory behind ion traps could be applied to smaller, commercial mass spectrometers, then these portable mass spectrometers would be more sensitive and therefore more useful for monitoring air quality or detecting compounds related to nuclear or chemical weapons.

Our miniature mass spectrometer is based in part on the principles behind a research ion trap developed at Harvard, but instead of filling an entire room with ancillary equipment as does the research mass spectrometer, the Livermore National Laboratory invention weighs just 15 kg, operates off a battery, and fits into

Above photo: Miniature mass spectrometer shown in its suitcase.

the middle of the cylinder. The huge magnets can keep individual ions in orbit inside the trap for weeks, which is what allows these ion traps to be so extraordinarily accurate.

While the miniature mass spectrometer is about the same size as the trap in the research units, the magnetic field is provided by a small permanent magnet, greatly reducing the overall size and power requirements of the unit (Fig.1). The designs of the trap, the electron source, the vacuum system, and the inlet valve are also new. We are aiming for a residence time of 100 ms, which will provide sufficient resolution to detect trace compounds in air.

Several innovations in this ion trap keep power consumption very low, to about half a watt. (This does not include the 20 W needed by the laptop computer that accompanies the device.) The permanent magnet is the most obvious power saver. The unique design of the inlet valve is also important. In most ion traps, gas is continually bled in, which then requires large pumps to maintain the vacuum in the trap. This new inlet valve lets in gas in small pulses, reducing vacuum pumping requirements. The vacuum pump itself is also a new power-saving design.

Laboratory mass spectrometers are complex instruments requiring highly trained operators. The miniature mass spectrometer is inexpensive and portable and will have numerous applications outside the laboratory. For example, these units can act as air-quality monitors in closed or confined spaces, such as factories where chemical-weapon manufacturing is suspected. They could be incorporated into feedback control loops and alarm systems in homes, offices, or factories to warn of hazardous conditions. Home units could monitor freon and radon as well as carbon monoxide, carbon dioxide, methane, propane, and other hydrocarbons. With the addition of other front-end sensors, airborne disease agents could be detected. Law enforcement agencies could replace breathalyzers and drug- and explosives-sniffing dogs.



Figure 1. This view of the miniature mass spectrometer outside its suitcase shows the small magnet in the middle of the cylinder.

Testing drivers for alcohol or sniffing out drugs could be performed remotely, increasing safety for police officers and others. Industries with critical process control applications could monitor for a variety of chemical species, such as chlorofluorocarbons, hydrazine, helium, nitrous oxide, nitrous dioxide, and sulfuric acid. ❁

CONTACT: **Dan Dietrich**
Lawrence Livermore National Laboratory
PHONE: 510-422-7868
FAX: 510-423-6998
EMAIL: dietrich1@llnl.gov

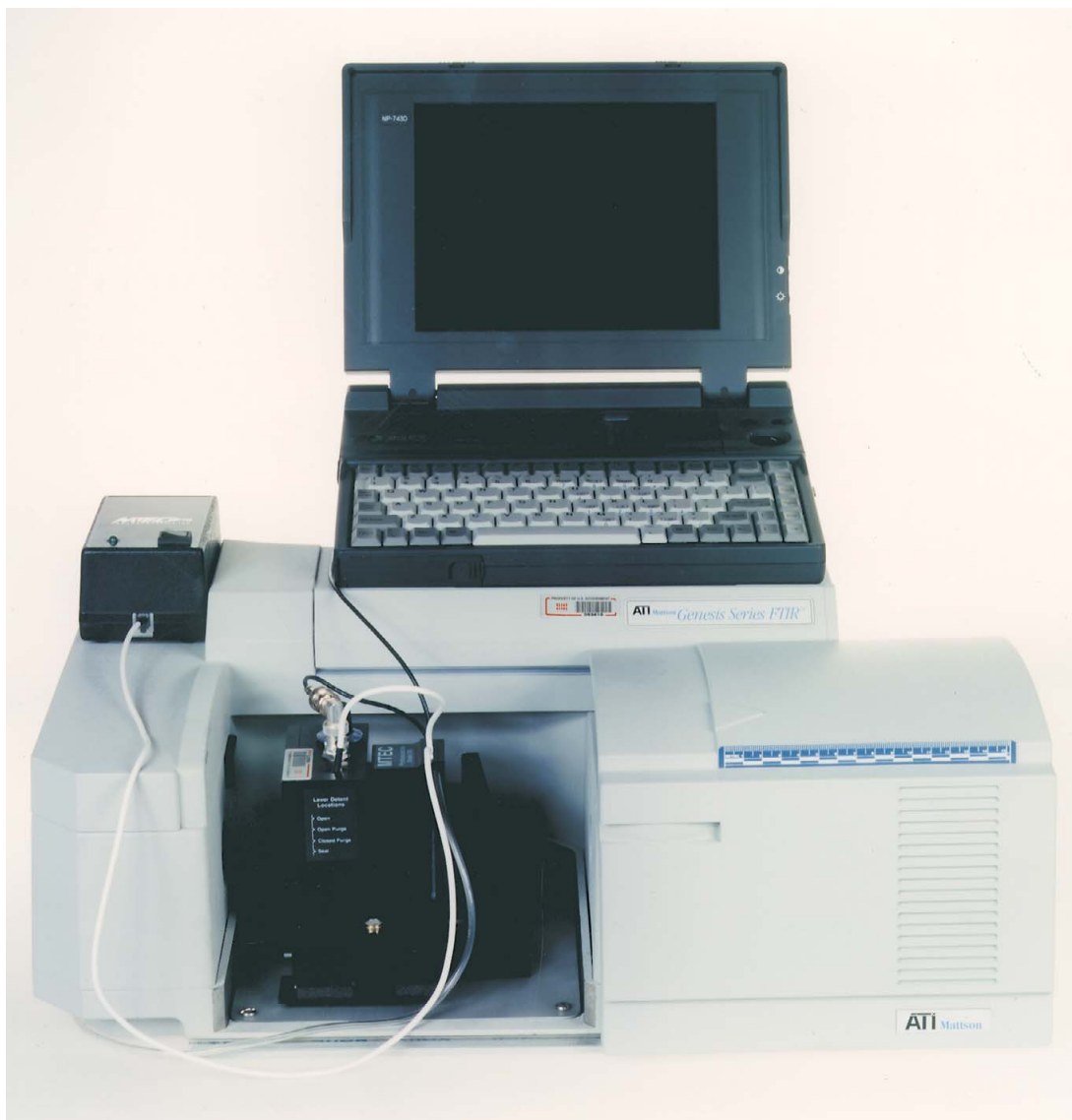

Photoacoustic Spectrometer to Identify Small Samples (ST597)

We have assembled a portable spectrometer that can identify key chemical signatures in small samples of solids or liquids taken from the chemical processing activities of a suspect production facility. The equipment is packed into three containers, each weighing less than 32 kg. Two people can unpack and operate the equipment in under 20 minutes.

The photoacoustic spectrometer measures the spectral “fingerprint” of virtually any solid and of many liquids. Potential

samples include powders, plastics, textiles, biological samples, and drugs. Samples are brought to the work station and put into cups that hold 10–30 mg of a solid or liquid. Testing an individual particle (micrograms of material) requires a few minutes to mount the particle onto a tungsten needle. Once the sample is loaded into the detector, a portable computer controls the scan. After scanning is complete, a simple search command displays the most probable identity of the sample.

Above photo: Portable photoacoustic spectrometer.

For reasonably pure samples, the whole process from loading to identifying the sample takes no more than 10 minutes. Identifying trace contaminants requires a longer scan and additional information being incorporated into the search. A limit of detection in the parts-per-hundred (pph) range requires scanning for 15 minutes to 1 hour. We are developing new detectors to significantly improve the limits of detection as well as the data-collection speed.

Photoacoustic detection is a very general method of obtaining spectral fingerprints because it is independent of all the optical properties of the sample except for its absorption. Surface roughness, average particle size, and opacity affect overall signal strength, but positions of the peaks are unaffected. The only requirement for generating a signal is that the sample converts some of the incident light into heat. The light that illuminates the sample must have a modulated intensity so that heat is released in periodic waves, creating a pattern of pressure waves that can be detected by a microphone as sound. Our photoacoustic spectrometer currently uses an infrared source to heat the sample, but we are working to extend the results to the visible and near-ultraviolet regions of the electromagnetic spectrum. The infrared spectrum of a sample is particularly useful because this is the region where molecular vibrations are active. The pattern of vibrational frequencies depends on molecular shape and symmetry as well as on the strength of each chemical bond and the masses of the constituent atoms; therefore, each chemical species has a unique infrared spectrum.

In addition to quickly and easily acquiring reference spectra of a wide range of inorganic solids and several organic liquids,

we have also succeeded in obtaining spectra of complex contaminated solids with sufficient accuracy to determine the presence of individual contaminants. An example of determining trace quantities of contaminants is found in our work with soils. In one series of experiments, we exposed soils to gaseous nitrogen dioxide (NO_2)—an important pollutant in acid rain that is produced during the processing of many metals, including uranium. Infrared spectra were taken of both unexposed and exposed soils. Spectral subtraction showed nitrogen atoms double-bonded to oxygen atoms on the surface of the samples exposed to nitrogen dioxide. This result was confirmed six months later when spectra were taken of the same exposed and unexposed samples and, after spectral subtraction, the peak due to the N-O double bond was still observed. Since NO_2 gas would have diffused away from the exposed sample during this time, we conclude that the effects of exposure to NO_2 are long-lasting. In other words, the nitrogen dioxide reacted with the sample to create stable nitrate or nitrite groups that gave rise to the observed spectral peak.

In another experiment, we took the soil spectra before and after contamination with less than 1% uranium oxide (U_3O_8). After subtracting the former spectrum from the latter, the difference was compared to the spectrum of pure U_3O_8 and found to be nearly identical. We are currently developing a dual-beam detector designed to give the difference signal of two samples directly—bypassing the need for taking two spectra consecutively and then subtracting the results mathematically. Differential measurements will increase the dynamic range of the instrument. *

CONTACT: **Peter Vanier**
Brookhaven National Laboratory
PHONE: 516-282-3535
FAX: 516-344-1427
EMAIL: vanier@bnl.gov



Very Small Gas Chromatography-Mass Spectrometry Instrument (ST240)

Capillary gas chromatography (GC) combined with computer-aided mass spectrometry (MS) creates an analytical tool that rapidly and completely characterizes individual compounds in environmental samples. Recently, GC-MS instrument manufacturers have integrated GC with MS into field units with analytical capabilities previously available only in the laboratory. Despite the 100-pound-plus weights of these instruments, their demonstrated field utility has triggered interest in even smaller, lighter instruments.

We have developed a portable GC-MS instrument with analytical capabilities similar to bench-top, GC-MS systems. Our current version was originally designed for on-site inspection teams supporting the Chemical Weapons Convention. The portability and capabilities of this integrated instrument make it useful for environmental monitoring and on-site analyses.

Our very small GC-MS instrument fits in two suitcases, about 24 × 46 × 69 cm. One suitcase contains the entire GC-MS instrument. The other suitcase contains all power and computers. The entire GC-MS system comprises a hydrogen-supplied, gas-chromatographic injector assembly; a conduction-heated and forced-air-cooled, small-bore capillary gas chromatographic oven; a commercial, dual-filament, electron-impact quadrupole mass spectrometer with an electron multiplier detector; a self-contained, ultralight weight ion/sorption vacuum pump; and a dual-computer system with software that controls all hardware and simultaneously acquires, analyzes, and archives data.

Our GC-MS instrument is designed with a small, heated GC injector that performs in a manner similar to commercial GC injectors. Microliter samples are injected and vaporized, using a custom-machined, temperature-controlled injec-

Above photo: Very small gas chromatography–mass spectrometry (GC-MS) instrument is split into two suitcases, computer and power on the left, GC-MS on the right.

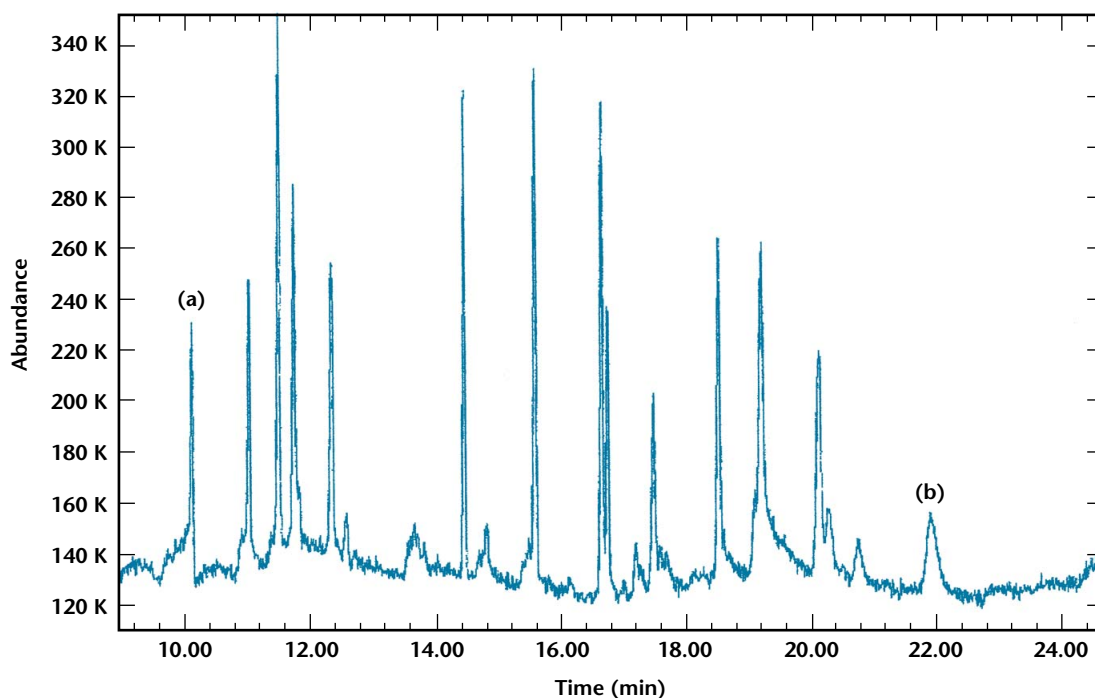

Figure 1. The total ionization plot of the very small gas chromatograph-mass spectrometry (GC-MS) instrument includes retention times for (a) diisopropylmethylphosphonic acid (10.0 minutes) through to (b) cocaine (22.0 minutes).

tor port. The injector is equipped with split/splitless hardware for samples that require high-resolution GC separations.

The gas chromatograph is constructed in a 2.54-cm-high \times 15.24-cm-diameter oven, enclosing a 15-m capillary column heated by a flat “pancake” heater. The column is programmed to any desired temperature at standard heating rates from ambient to 300°C.

A Hewlett Packard 5972A quadrupole mass spectrometer is self-contained and light-weight. We modified some hardware to hold the mass spectrometer in a stainless-steel vacuum housing.

The most important component of the very small GC-MS instrument is the vacuum system. To reduce weight, we did not use heavy mechanical, diffusion, or turbomolecular pumps to maintain the high vacuum. Instead, the pumping system uses strips of reactive gas “getter material” (Fe/Zr) configured into 18 (2.5 cm \times 9.6 cm) metal strips uni-

formly positioned around a central heater. This new design pumps 250 L/s to remove the hydrogen GC carrier gas. The completed vacuum system also includes a 6-L/s ion pump to remove trace amounts of non-reactive gases.

Two computer systems operate in parallel in the second suitcase. A removable 486 laptop computer acquires, displays, analyzes, and stores mass spectral data (Fig. 1). A second embedded microcomputer controls the instrument heaters, gas switching, calibration, and vacuum pumping system. This system approach consumes minimal power when the instrument is in stand-by. ❁

CONTACT: **Brian Andresen**
Lawrence Livermore National Laboratory
PHONE: 510-422-0903
FAX: 510-423-9014
EMAIL: andresen@oberon.llnl.gov

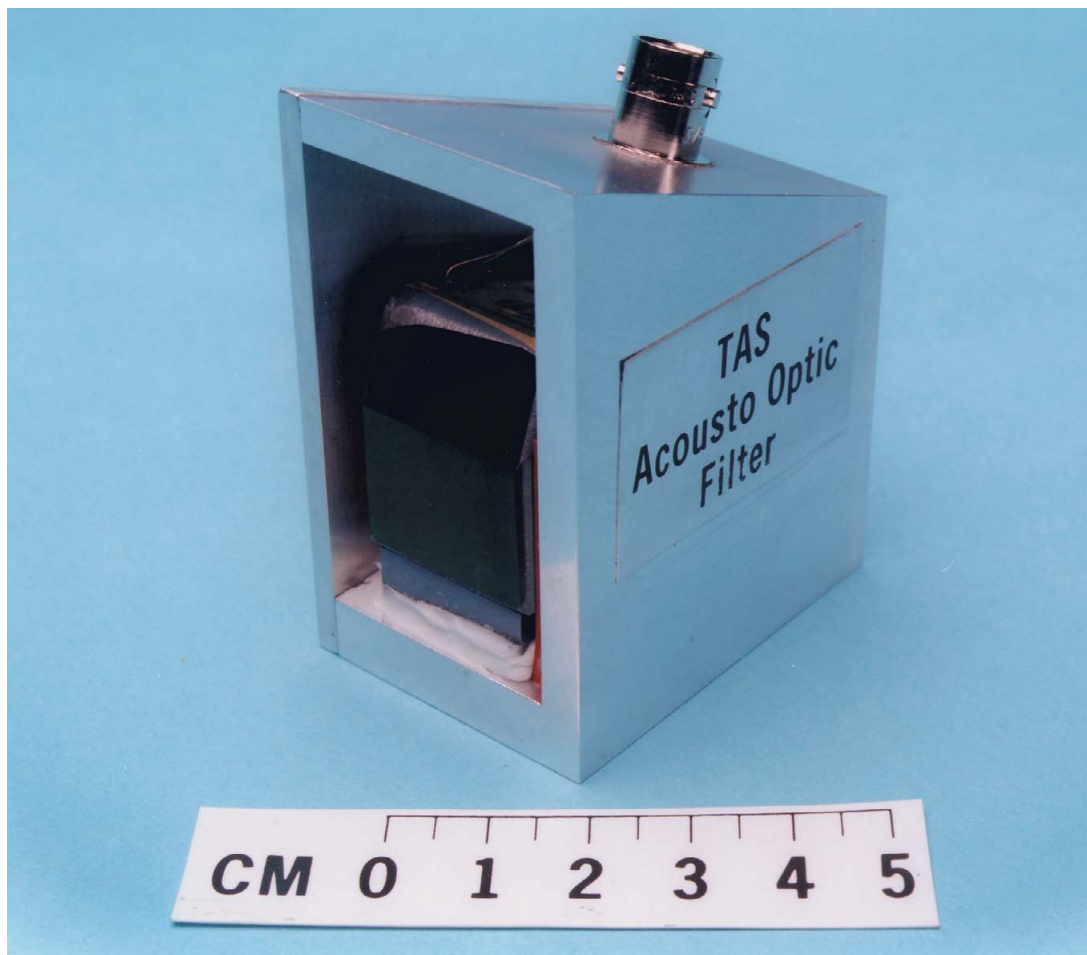

Detecting Airborne Chemicals by an AOTF Spectrometer (SR003)

Above photo: The acoustic-optic, tunable-filter (AOTF) spectrometer uses a nonlinear optical material, thallium arsenic selenide (TAS).

The Savannah River Technology Center (SRTC) is developing an acoustic-optic, tunable-filter (AOTF) spectrometer to identify and quantify airborne chemicals. The system will operate passively using the sky or the ground as a thermal radiation source. An infrared spectral library containing the most important effluents characteristic of separation processes in nuclear facilities will be created and added to the spectrometer.

Minimum detection levels for most airborne chemicals of interest are expected to be in the parts-per-million-meter to the parts-per-billion-meter concentration range. The spectrometer design will allow for ground- and air-based applications.

The AOTF spectrometer will allow an operator to image a plume and identify its chemical constituents according to the infrared spectral signatures. The instrument will identify chemicals in the 8–12 μm

spectral region of the electromagnetic spectrum (atmospheric window) with little or no spectral interference from atmospheric gases. Because most of the polyatomic molecules of interest to proliferation have absorption bands of spectral bandwidths greater than 2 cm^{-1} , the AOTF spectrometer is designed to optimize its light conversion efficiency at this resolution.

To maximize light collection in the spectrometer and use its large field of view ($20^\circ \times 15^\circ$), the optical aperture of the AOTF crystal will be matched to a commercially available Inframetrics 760 camera. The images from the Inframetrics 760 camera will be recorded by a real-time data-acquisition system. The industrial computer source system (D*STAR) will allow 20 minutes of recording time. The AOTF spectrometer will be controlled by software written in C++ language. Commercially available software will be used for image and data analyses, such as recording, averaging, subtracting, chemical identification, and quantification. Figure 1 shows a schematic of the AOTF spectrometer.

Infrared absorption spectroscopy is used extensively to identify fairly large molecules. The power of infrared spectroscopy lies in the unique sets of molecular vibrations associated with each molecule, their respective band energies, and intensities located in mid-infrared region ($2.5\text{ to }50\ \mu\text{m}$).

Facilities involved in the separation of plutonium will release a variety of chemicals to the atmosphere. Over 30 possible chemical effluents related to the processing of nuclear materials and their respective infrared spectra have been added to the computer library. We performed modeling calculations to determine minimum concentration detection levels in the passive mode. Chemical detection probabilities have also been calculated. ❁

CONTACT: **Eliel Villa**
Savannah River Technical Center
PHONE: 803-725-1185
FAX: 803-725-4478

▼ **Figure 1.** The acoustic-optic, tunable-filter (AOTF) spectrometer has a 4-cm interaction length and a $1\text{ cm} \times 1.5\text{ cm}$ aperture.

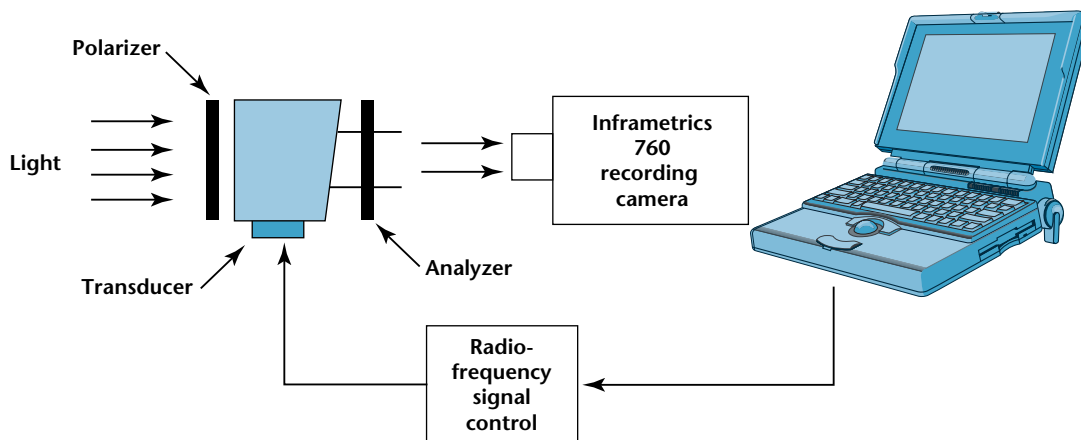



Millimeter-Wave Detection of Airborne Chemicals (ST214)

The objective of the millimeter-wave (mm-wave) detector project is to develop a real-time sensor for remote or standoff monitoring of airborne effluents associated with the production and testing of weapons of mass destruction. Two prototype sensors, one based on an active mode for short-range (1–3 km) detection and the other based on a passive mode for long-range detection, will be built and tested for their effectiveness against various target chemicals under a variety of conditions.

The detection of chemical species is based on measuring the molecular rotational energy transitions at mm-wave frequencies. The mm-wave technique offers

better transmission properties than optics do in harsh industrial environments, such as smoke, dust, aerosols, and steam, as well as in adverse atmospheric conditions. Although mm-wave spectroscopy is an established laboratory technique for molecular spectral studies under low pressures, it has not been explored for open-air monitoring, primarily because of a lack of high-frequency, wide-bandwidth sources and detectors. The latter situation has been altered by recent access to mm-wave, backward-wave oscillator technology from Russia, as well as by advances in mm-wave radioastronomy.

Operating in the 225- to 315-GHz atmospheric transmission window, a radar-

Above photo: Millimeter-wave radar system shown assembled on a cart.

based active sensor and a radiometer-based passive sensor are being developed to remotely detect chemicals in the open air. The active system has a monostatic radar configuration with the transmitter and receiver on one side of the plume to be measured and a corner cube or a terrestrial target on the other side. A wide-band, swept-frequency, mm-wave signal is transmitted through the plume, and the return signal from the reflecting target is detected by an ambient-temperature, solid-state detector or liquid-helium-cooled bolometer. Absorption spectra of the plume gases are measured by comparing the return signals with and without the plume in the beam path.

In the passive system, the temperature contrast between the molecular cloud and the background is measured as a function of frequency. Molecular emission lines are measured when viewed against a cold background (such as sky or terrestrial targets such as concrete or water), and absorption lines are measured when viewed against celestial bodies, such as the sun.

We have determined the detection sensitivity of chemicals indicative of nuclear proliferation; laboratory measurements indicate that key signature molecules can be measured with a sensitivity of tens of parts per million over a 1-m path length. Using a signal-processing technique based on deconvolution, we have shown a high specificity of detection for resolving individual chemicals from a mixture. The active-mode system has been tested for proof-of-principle by releasing and detecting simulated chemicals in the open air (Fig. 1). Open-path tests continue to assess atmospheric effects (such as scintillation and turbulence) on spectral measurements. A prototype active-mode sensor, near completion, uses the unique (broad-band) Russian backward-wave oscillators at the transmitter end. Field tests are planned with this system. The passive-mode system has also been tested by a four-channel radiometer in the 77- to 83-GHz range. The prototype passive-mode sensor has been completed, and we are now building a 16-channel

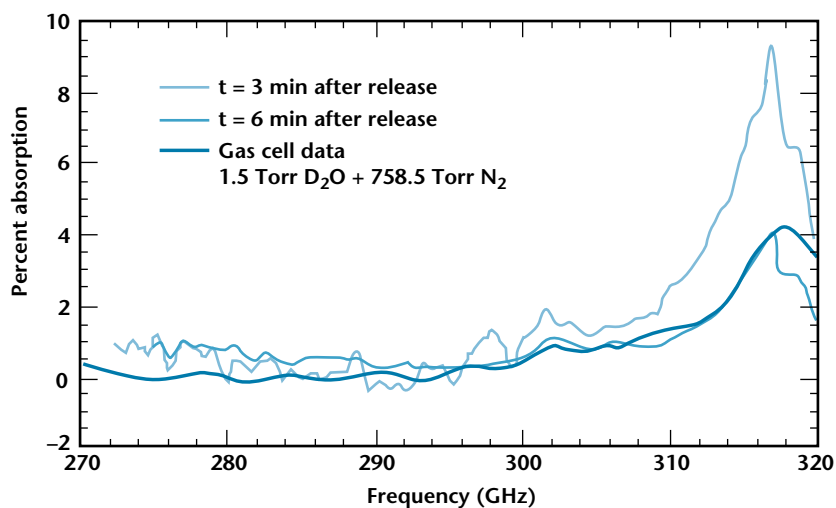
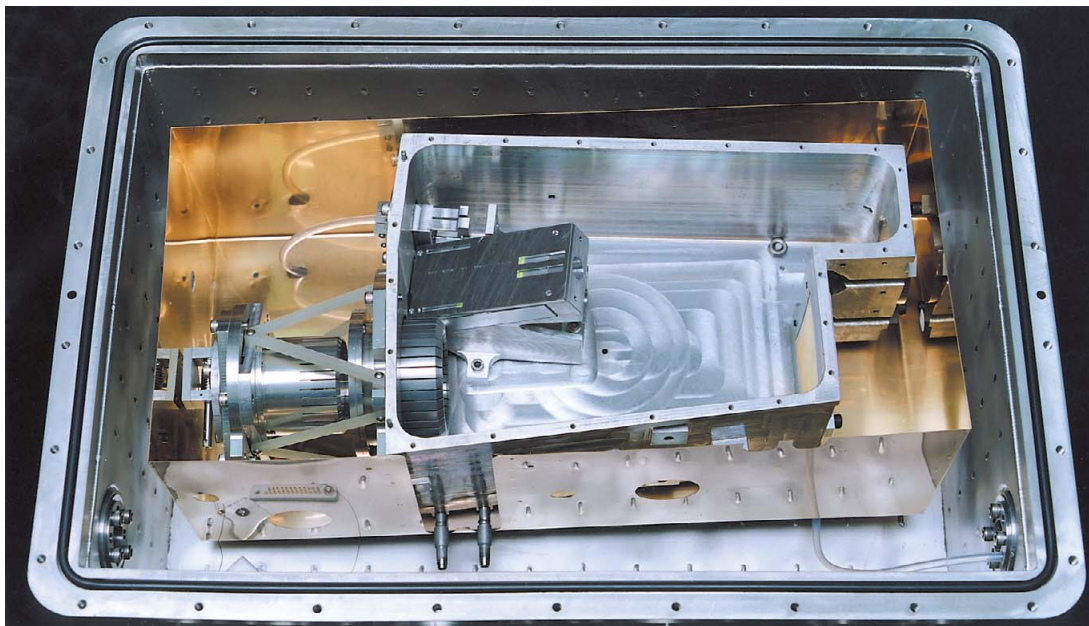

Figure 1. An open-path measurement of heavy water tested release and detection by the millimeter-wave radar system.

radiometer in the 311- to 319-GHz frequency range.

The mm-wave sensor can be either fielded on the fence line of a declared facility for standoff monitoring, or mounted on an airborne platform to survey suspect proliferation sites. The system will measure mm-wave absorption/emission spectra of selected molecules in effluent plumes. Because mm-waves can penetrate through cloudy and dusty environments, the system can operate under adverse weather, day or night. With the addition of a scanning feature, the system can also spatially map chemicals in a plume. In light of the Clean Air Act amendments, the mm-wave sensor could be used for continuous emission monitoring of industrial effluents. ❁

CONTACT: **Sami Gopalsami**
Argonne National Laboratory
PHONE: 708-252-5925
FAX: 708-252-3250
EMAIL: n_gopalsami@qmgate.anl.gov



Remote Infrared Chemical Sensing (ST740)

The ability to remotely and unobtrusively interrogate the activities taking place within manufacturing facilities offers an effective way to monitor treaty compliance and detect weapons of mass destruction. Remote-sensing approaches to this problem rely principally on the interpretation of photographic evidence and other inferential and indirect processes. A more direct approach lies in measuring chemical constituents from the exhaust plumes of manufacturing facilities.

All manufacturing facilities emit chemicals from exhaust stacks and vents, and these emissions carry detailed information about the processes within. Manufacturing processes follow fixed patterns of individual steps, each pattern with a characteristic suite of chemicals. These patterns provide a unique signature of each process step. Chemicals absorb and emit infrared radiation in characteristic frequency patterns. Remote instruments, equipped with

infrared sensors that measure these patterns with sufficient resolution and sensitivity, can detect and identify these chemicals. These data combined with a knowledge of the chemical engineering behind manufacturing processes can reveal the nature of the activities taking place inside the facility.

The ROMAC project (Remote Optical Measurement of Airborne Chemicals) introduced the concept of cross-dispersion spectrometry to the infrared region for remote sensing. A two-dimensional (2-D) spectral format is created that then uses a two-dimensional detector array. This approach allows us to display entire regions of the infrared in a single snapshot without moving components. The array pixels can be divided between spatial and spectral features. In our design covering the spectral region between 2 and 4 microns (the mid-infrared region), we resolve ~13,000 spectral features over 10 spatial locations.

Above photo: A view of the second-generation spectrometer being developed under the Remote Optical Measurement of Airborne Chemicals (ROMAC) project.

This method of spectral display has many advantages over more conventional approaches. The most apparent advantage is its simple operation. It is also more sensitive than other approaches. Full spectral coverage in the infrared means that the characteristic spectral fingerprints of all chemicals fall within its measurement domain. The enhanced sensitivity of this instrument means that chemicals present in much lower concentrations can be detected.

During the past year, we demonstrated our first-generation instrument, flying over the San Francisco-Bay Area aboard a commercial blimp. Figure 1 illustrates the spectral data gathered during these flights. The picture shows spectral data obtained from an area near a power plant where reflected-sunlight infrared radiation from the ground was used to interrogate the chemical composition of the atmosphere in this location. A spectrum developed from the 2-D display reveals the presence of characteristic absorption features for carbon monoxide, carbon dioxide, methane, and water vapor. These spectra illustrate the fingerprint-like patterns of particular molecules. The measurement precision is approximately 1% with an accuracy estimated at 6%. Our goal is to achieve precision levels better than 0.1% over a 100-s observation time. To achieve that kind of performance using diffusely reflected sunlight from an arbitrary ground location, we must cool the spectrometer to a point where the infrared emission from the warm walls of the spectrometer no longer contribute to background noise.

We are testing a second-generation, cross-dispersive spectrometer. This new, smaller instrument is cooled to 150 K for highly sensitive, low-noise performance. The key enabling technology for this instrument is the development of a new type of infrared grating called an immersion

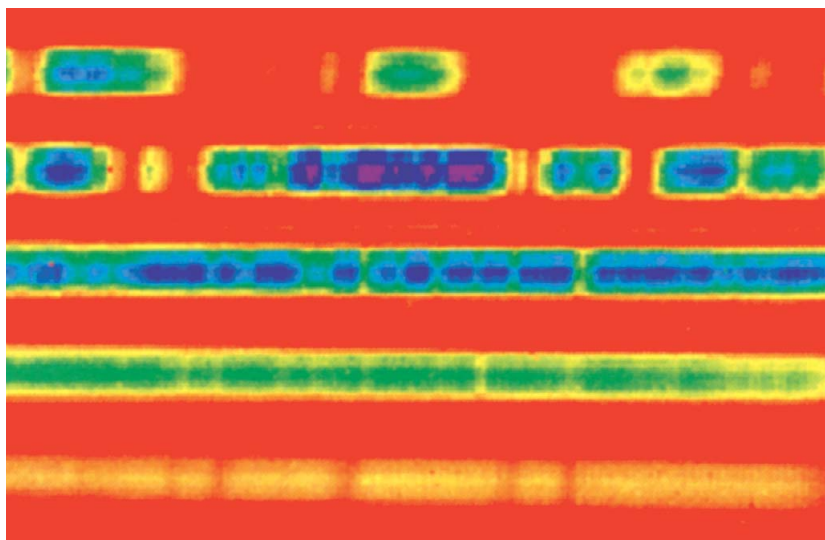
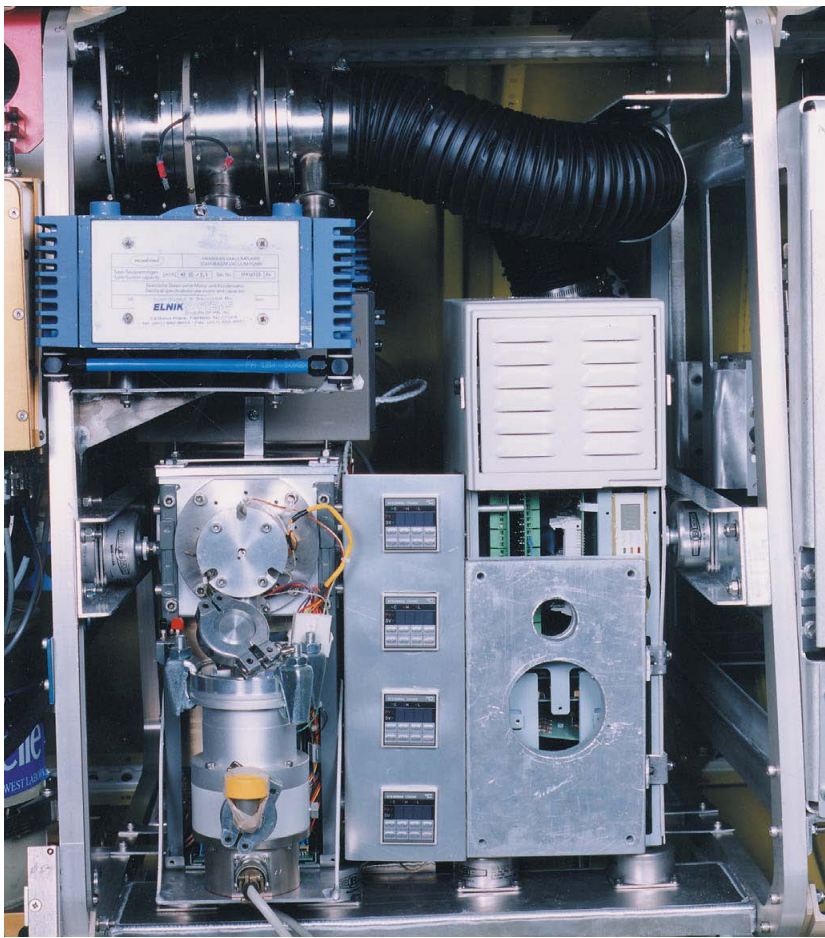

Figure 1. The first-generation instrument gathered spectral data during flights over the San Francisco-Bay Area; shown here are characteristic absorption patterns for various chemicals near a power plant.

grating. This grating is etched from a single crystal of silicon using a chemical etching procedure we developed to achieve very nearly atomic-level precision. The very high optical index of silicon increases the dispersion and resolving power of the grating, thereby reducing the spectrometer size without sacrificing performance. *

CONTACT: **Chuck Stevens**
Lawrence Livermore National Laboratory
PHONE: 510-422-6208
FAX: 510-424-6089
EMAIL: stevens2@llnl.gov



Real-Time Analyzer for Airborne Chemicals (ST447)

We are developing a highly sensitive instrument that detects airborne chemicals, in real time, and in the parts-per-trillion or lower range. The instrument, being developed for the Department of Energy's Airborne Multi-sensor Pod System (AMPS) Program, can analyze most organic compounds present in the air as vapors or adsorbed onto particles, as well as volatile, inorganic species. In brief, the instrument incorporates a dual-stage, large-volume air concentrator sampling system coupled with state-of-the-art ion trap mass spectrometry. A prototype has been fabricated and has had limited flight testing.

Designed to fit in the third AMPS pod, the ion trap mass spectrometer/air concentrator (ITMS/AC) had both size and weight limitations (Fig. 1). The prototype fits into an area approximately 53 cm in width, 81 cm in depth, and 81 cm in height. It weighs approximately 99 kg,

including all mounting hardware. A laptop computer controls it, with Ethernet™ providing remote access through the aircraft. The system consists of three modules—a large-volume air sampler, a mass spectrometer, and an electronics tower. Samples are collected, concentrated, and subsequently introduced to the mass spectrometer using the dual-stage, large-volume air concentrator. Batch operations require a few minutes. The instrument can also operate in real time, during which instantaneous measurements are made by sampling air directly (without pre-concentration) into the mass spectrometer.

The dual-stage, large-volume air concentrator consists of a primary adsorber/desorber unit (collector) followed by a secondary adsorber/desorber unit. Air from the exterior of the aircraft is sampled through the primary collector (a porous adsorbent bed) for 1–10 minutes at approximately 0.5–2.0 m³/minute. As the air flows through and exits the primary collector, chemicals are retained by the adsorbent. After air sampling, the primary collector is closed and the adsorbent bed is heated, causing the collected compounds to be thermally desorbed and released from the adsorbent. The compounds are back-

Above photo: The prototype of the ion trap mass spectrometer/air concentrator (ITMS/AC) shown inside the aircraft pod.

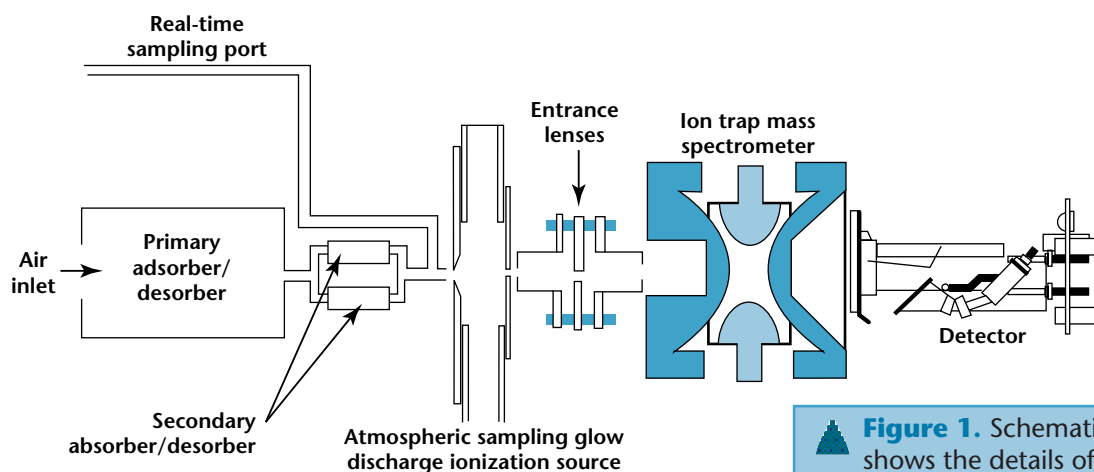

Figure 1. Schematic of the ITMS/AC shows the details of the mass spectrometer module and the large-volume air sampler.

flushed to the secondary collector where they are retained by a smaller adsorbent bed and are further concentrated. Subsequent heating of the secondary adsorber/desorber unit causes the collected compounds to be thermally desorbed and released at a narrow plug where they are directed to the mass spectrometer. The primary collector is cooled and re-equilibrated for the next large-volume air sampling during the secondary desorption step and mass spectrometry analysis.

The analysis portion of the instrument consists of an ITMS equipped with both external and internal ionization sources and an oil-free vacuum system. Mass spectrometric analysis is highly desirable because it provides selective and compound-specific information to determine target analytes.

The ITMS has several features that make it highly attractive for airborne atmospheric monitoring, including small size, relatively rugged components, excellent sensitivity, and broad applicability. The ITMS system, based on a commercial Teledyne 3DQ, was adapted for multiple ionization methods and the detection of both positive and negative ions. The external source is an atmospheric sampling glow discharge source that offers relatively “soft” ionization (e.g., allows high molecular ion production of labile molecules) at high efficiency. The internal sources are the common electron impact and chemical ionization methods. Moreover, this ITMS allows for selective trapping of ions at

specified m/z values (for either of the sources) through the use of the Filtered Noise Field™ (FNF) method. Because of this, background or unwanted ions can be excluded from the trap in real time, enhancing sensitivity. Trapped ions can be further ionized (MS/MS techniques) for more in-depth characterization. A three-stage vacuum system constructed of rugged turbomolecular, molecular drag, and diaphragm pumps provides oil-free operation.

The sensitivity of the system is anticipated to be high. For real-time measurements, we predict detection in the 1 to 10 parts-per-billion range. Accordingly, we expect detection in the 10 to 100 parts-per-trillion range for specific compound sampling using FNF. When the large-volume air sample unit is used, we will expect detection in the 1 to 10 parts-per-trillion range, with a conceivable increase in detection to the 10^{-2} to 10^{-3} parts-per-trillion range when FNF is applied. The ultimate limits of detection, however, depend on many parameters, including the air volume sampled, ion trapping time, the complexity of the air sample, and the specific compounds. ❁

CONTACT: **Bob Wright**
 Pacific Northwest National Laboratory
 PHONE: 509-376-1661
 FAX: 509-376-5021
 EMAIL: bw_wright@ccmail.pnl.gov

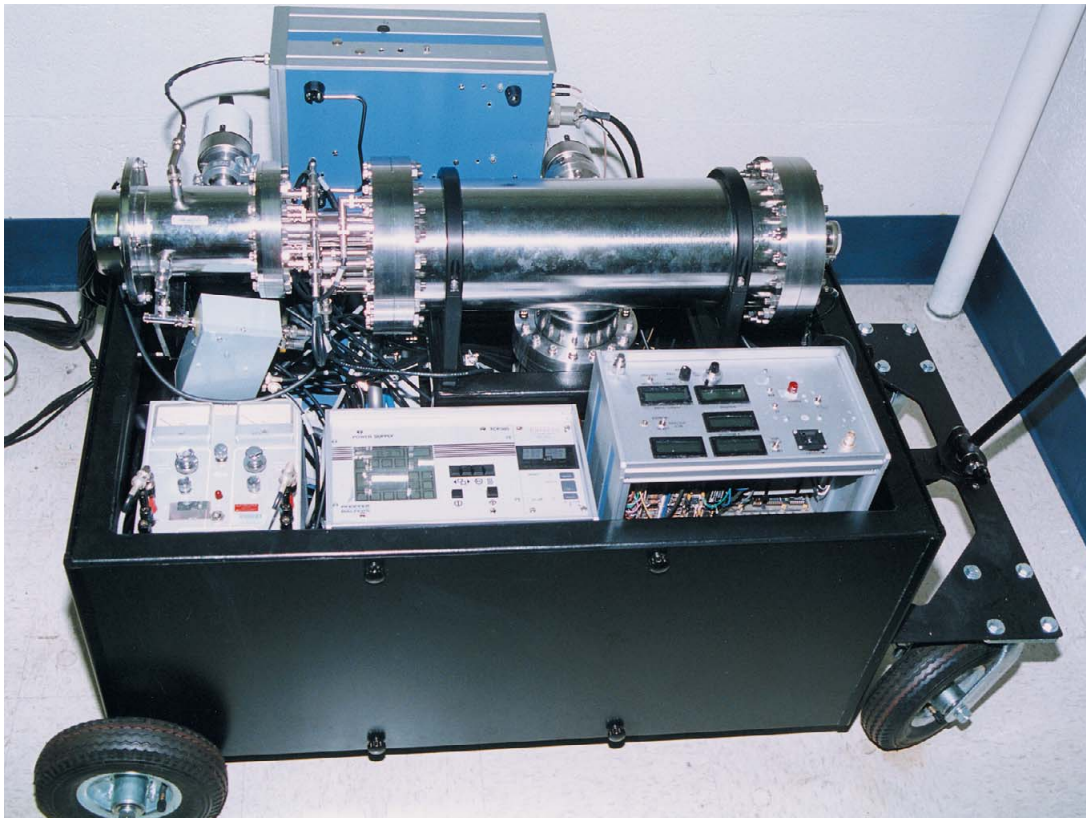

Real-Time Monitoring of Volatile Compounds: Ion Store/Time-of-Flight Mass Spectrometer (ST610)

We have developed a highly sensitive (sub-parts-per-billion) mass analyzer for real-time analyses (10–100 ms/scan) of volatile compounds in air. This instrument offers selective and specific chemical information on a wide range of compounds. Air is drawn directly into the mass spectrometer and analyzed. This system is ideal for automated monitoring in the field because samples require no preparation.

The instrument is divided into two regions, one housing the ionization source and ion store and the other a time-of-flight

mass spectrometer (TOF-MS). Target chemicals are directly sampled into the ion store where they are ionized, primarily by charge exchange with the N_2^+ and O_2^+ formed by electron impact. During this process, the ion store is set to continually eject these ions, thus accumulating only larger analyte species. Generally, analyte accumulation lasts approximately 100 ms, at which point the ions are extracted into the TOF-MS and analyzed in less than 100 μ s. This approach is unique because it yields the fastest analysis time and highest duty cycle (nearly 100%) of all mass spectrometry

Above photo: The prototype of the ion store/time-of-flight mass spectrometer.

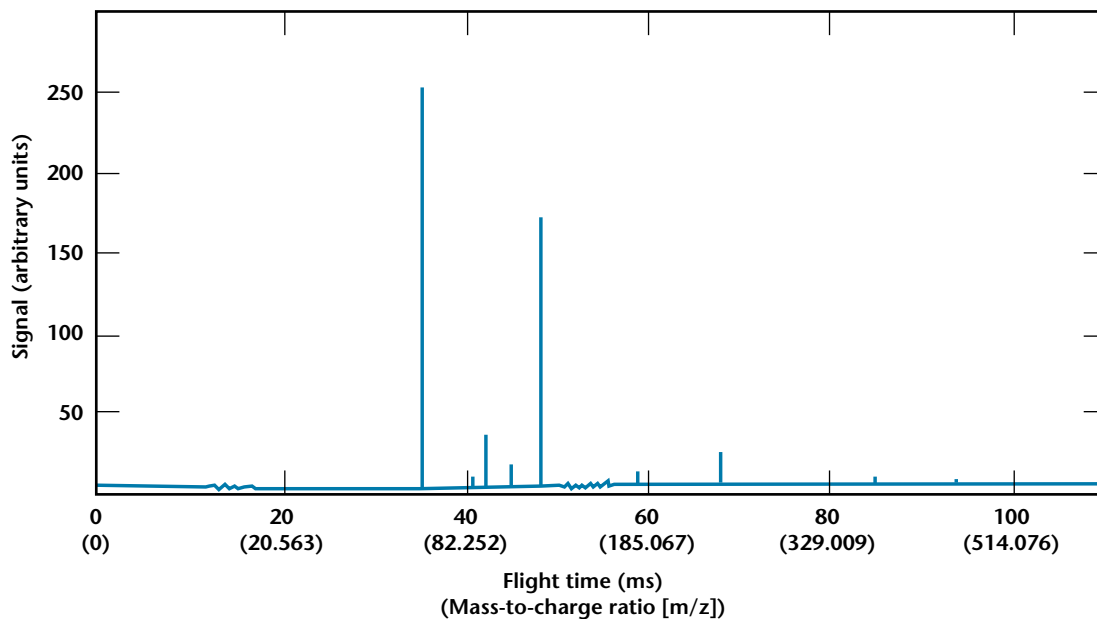

 **Figure 1.** A full-mass scan of perfluorotributylamine demonstrates the real-time air-monitoring capability of the prototype.

techniques. In addition, this instrument is capable of achieving relatively high resolution of 1200 $m/\Delta m$ at full-width half maximum, even for lower mass ions. The real-time air monitoring capability is seen in Fig. 1.

Development is ongoing to produce a high-performance field instrument with a short flight tube, compact electronics, and a fast data system that can process and store data at these analysis speeds. Possible applications include identifying hazardous chemical spills, monitoring volatile compounds from industrial stacks, surveying environmental areas, detecting concealed contraband, and detecting chemical and biological weapons manufacturing. 🌟

CONTACT: **Dave Chambers**
 Lawrence Livermore National Laboratory
 PHONE: 510-423-1189
 FAX: 510-423-9014
 EMAIL: chambers2@llnl.gov



Xenon Radionuclide In-Situ Analysis (ST583)

Noble-gas radionuclides are by far the most likely fission products to enter the atmosphere from sub-surface nuclear weapons testing. The noble-gas radionuclides ^{133}Xe (5.243 day) and ^{135}Xe (9.10 hour) are the most abundant at post-detonation times of hours to a few days. While ^{135}Xe decays to insignificant values after one week, ^{133}Xe is the most abundant noble-gas fission product through about 80 days post-detonation.

The sensitivity with which ^{133}Xe vented from a nuclear detonation can be measured in the atmosphere is limited by its background concentration, which is maintained

by leakage from nuclear power reactors and, to a lesser extent, by losses from medical diagnostic procedures. The background concentration of ^{133}Xe is highest in the “reactor belt” (30° to 60°N latitude) where its concentration appears to be >50-fold higher than that of ^{135}Xe . However, the concentration of ^{133}Xe is about 400-fold lower than ^{135}Xe where venting occurs minutes after a sub-surface nuclear detonation. Thus, the simultaneous observation of both ^{133}Xe and ^{135}Xe provides a method of distinguishing vented xenon radionuclides from other sources (Fig. 1).

Above photo: The laboratory prototype xenon radionuclide in-situ analyzer.

We are developing an in-situ instrument to automatically and continuously analyze airborne ^{133}Xe and ^{135}Xe in near real time. The instrument continuously extracts xenon from the atmosphere at a rate that permits measuring the two xenon radionuclides at concentrations as low as $20 \mu\text{Bq}/\text{m}^3$ of air. This is a 50-fold higher sensitivity than laboratory-based analysis technology. The instrument operates with a minimum amount of power ($\sim 2.5 \text{ kW}$), is remotely programmable, and requires no consumables.

Xenon from the atmosphere is separated by passing filtered dry air through a cold charcoal sorption bed. The xenon is selectively and thermally desorbed, purified by re-adsorption, and measured by beta-gamma coincidence counting in a gas cell scintillation counter. Xenon is continuously separated from the atmosphere at a flow rate of 40 m^3 per eight-hour collection period. During the next 32 hours, four gas samples are measured simultaneously. As soon as statistically valid data are accumulated, abnormally high concentrations of xenon radionuclides are reported. Gamma-ray spectra and radionuclide concentrations are automatically transmitted to the appropriate organizations.

The initial prototype is approximately $1 \times 1 \times 2 \text{ m}$. All major components of the system have been tested in the laboratory,

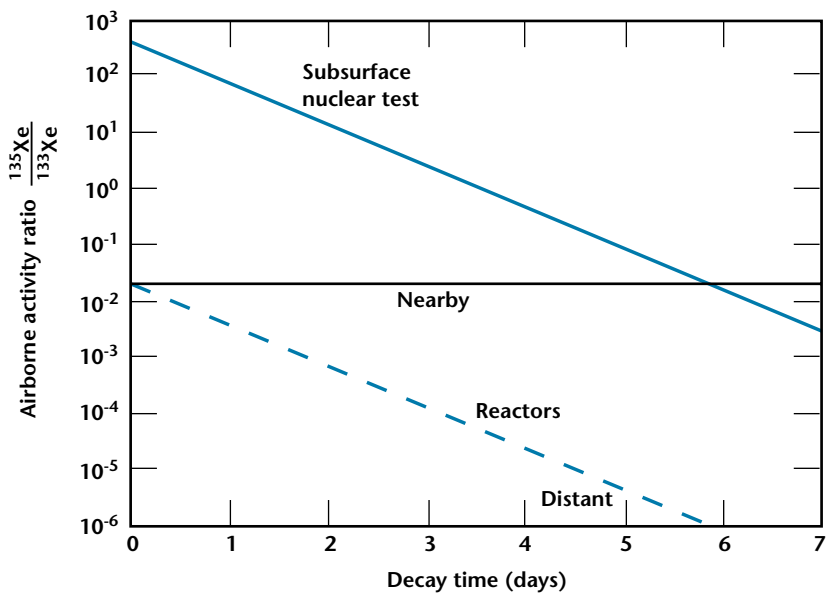

Figure 1. Xenon isotope ratios from weapons tests are compared to nuclear reactors.

and a fully automated prototype is operating. A ruggedized field instrument is being assembled and subsequent field tests will begin in January 1996. During this period, provisions for automatic data transfer will be implemented. During subsequent years, background counts will be measured at various locations to establish the range of ^{133}Xe and ^{135}Xe concentrations that may be encountered at proposed sites for an International Monitoring System. ❁

CONTACT: **Ted Bowyer**
 Pacific Northwest National Laboratory
 PHONE: 509-373-9799
 FAX: 509-376-2329
 EMAIL: tw_bowyer@pnl.gov



CAPS—Chemical Analysis of Proliferation Signatures (LL011)

Our multidisciplinary project, CAPS, stands for Chemical Analysis of Proliferation Signatures. CAPS ties together hardware development, current analytical techniques, and the development of new methods to identify chemical, elemental, and isotopic signature species. Our work supports the monitoring of nuclear proliferation and weapons of mass destruction.

The CAPS approach brings together several different techniques and applies them to sample analysis, collecting as much information as possible about the samples. Advanced analytical techniques delineate unique signature compounds at trace levels in complex matrixes. We have correlated and identified major and minor compounds with specific nuclear materials, events, and activities.

The CAPS approach maximizes the data gathered to support signature characteriza-

tion, relying on multiple analysis methods optimized for each type of sample analyzed. These methods can be grouped according to target species:

1. Inorganic explosive and propellant residues. Sub-parts-per-million detection is needed of explosion and propellant residues, including cations (e.g., magnesium, ammonium, barium, strontium, and lithium) and anions (e.g., perchlorates, nitrates, and nitrites). Simple and efficient methods using capillary electrophoresis have been developed, requiring no more than 5 minutes to completely analyze trace levels of a sample with a minimal amount of residual waste.

2. Radiolysis product identification. Nuclear-fuel reprocessing uses certain organic compounds and other inorganics radiolytically decomposed to evolve unique organic compounds. The simultaneous detection of key signature species and their

Above photo: Actinide complexation procedure being tested on a prototype field instrument.

radiolytic decomposition products could indicate nuclear reprocessing. New data have been generated with model systems exposed to high levels of radiation. From this ongoing work, unique signature compounds associated with different reprocessing activities are being identified. In addition, we are also investigating the sensitivity of target compound formation with radiation dose.

3. Actinide complexing and analysis.

Field samples (e.g., environmental and industrial materials) must be efficiently processed and analyzed for uranium and other isotopic species. In particular, it would be valuable to easily and conveniently generate volatile actinide compounds that could be isotopically characterized. We are developing a variety of ligands that specifically bind with uranium. These volatile derivatives may then be amenable to analysis with conventional instruments, such as gas chromatography-mass spectrometry (GC-MS), allowing rapid isotopic characterization of trace special nuclear materials (SNM) in the field.

4. Samples of opportunity. Samples of opportunity must be analyzed to test the instruments, analysis methods, and protocols developed and refined under the CAPS project.

5. Particle visualization and analysis by laser ablation/ion trap mass spectrometry. We are developing matrix-assisted, laser desorption/ionization (MALDI) techniques and hardware for ion trap mass spectrometry (ITMS) to characterize small particles in real time that may be associated with SNM. Particles are located in a complex background, selectively ionized, and analyzed by mass spectrometry. The whole process is recorded inside the source of an ion trap mass spectrometer for later correlation of the data with the size, shape, and color of the selected particles.

6. Age of highly enriched uranium (HEU). Nuclear decay and isotopic measurements to date the age of HEU require very sensitive assay techniques on specific isotopic species. Techniques are being refined to improve nuclear data acquisition and interpretation to date the age of HEU.

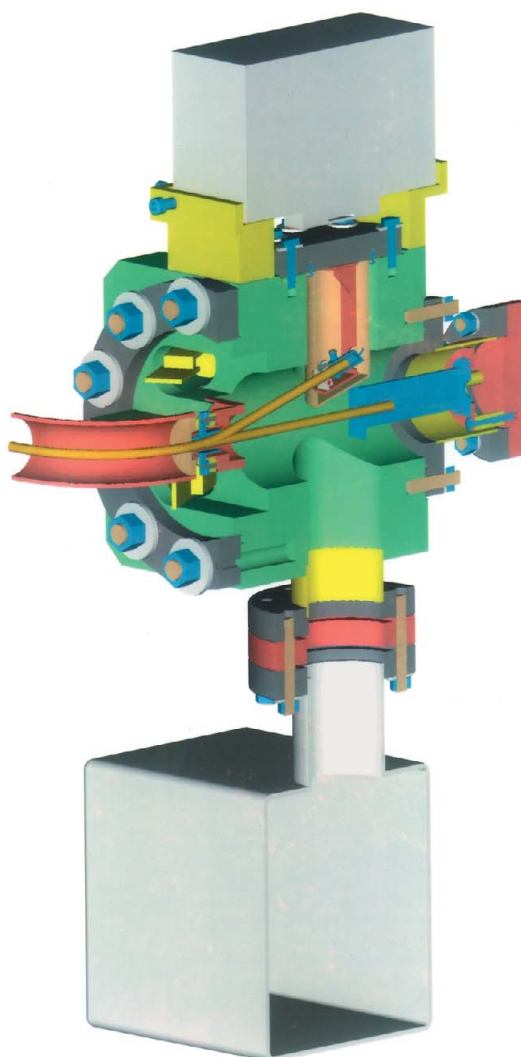

◀ **Figure 1.** The schematic shows an improved detector assembly, part of a hardware upgrade for an ion microprobe.

7. Uranium ore processing. Signatures associated with the processing of uranium ore are being defined and quantified. The identification of unique isotopic species associated with uranium ore processing can be important for determining source-terms and age-dating.

8. Ion microprobe analyses. Much of the ultratrace isotopic species identification necessary for the CAPS signature work can be supported by innovative techniques developed with ion microprobe analysis (Fig. 1). Our analytical upgrades and software are being tested in concert with other CAPS signature work. ❁

CONTACT: **Brian Andresen**
Lawrence Livermore National Laboratory
PHONE: 510-422-0903
FAX: 510-423-9014
EMAIL: andresen@oberon.llnl.gov



Particle Collection with an Electrostatic Precipitator (ST620)

Nuclear processes modify and produce unique elements and isotopes; particulate matter containing many of these elements and isotopes is released into the atmosphere. Modern analysis techniques of this particulate matter can provide significant information about the processes that formed the material and can help identify nuclear proliferation activities.

The objective of this project is to develop a versatile collection system that can be used in a variety of scenarios to collect particles released from nuclear facilities. Such a particle collector should be a low-power, efficient collector in a small, portable package. The sampler should also facilitate simplified analyses.

Above photo: Prototype of the portable electrostatic precipitator.

We have built and tested a small, portable, prototype electrostatic precipitator collector during the past two years. The unit is highly efficient, collecting in excess of 80% of the particles that pass through. Unlike particle collectors based on various filter media, the electrostatic precipitator has very little pressure drop, allowing a low-power blower to pump the air. It is also nearly impervious to plugging because of particle buildup on the collection plates. The sampler can collect in excess of a half-million particles per minute.

The first prototype we assembled had a collector originally used to study atmospheric pollution. The first prototype

demonstrated the feasibility of battery-powered, microprocessor control. The second prototype uses the modifications made to the original design with an improved ionization sector. The main, new feature in the second prototype is quiet operation, answering an objection raised by International Atomic Energy Agency (IAEA) personnel to the first prototype unit that had a mini-vacuum motor to move the air. The second unit is smaller and does not require a high air volume. The benefits for IAEA include direct counting for radionuclides and easy processing for gross analysis. ☼

CONTACT: **Cliff Carlson**
Savannah River Technology Center
PHONE: 803-725-1431
FAX: 803-725-4478

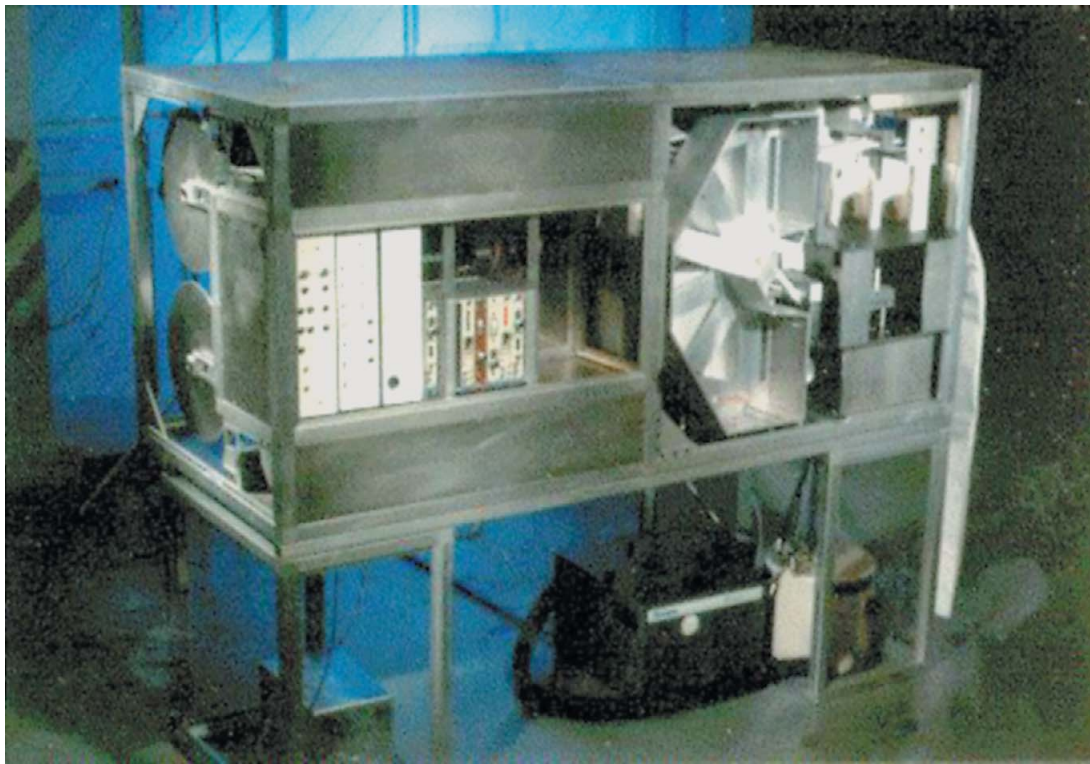

Real-Time Detection of Short-Lived Fission Products (ST271)

The Particulate Radionuclide In-Situ Analyzer measures short-lived fission products at ultrasensitive levels in near real time, permitting the detection of nuclear detonations at great distances from the detonation sites. Air passes through a large-area, low-pressure drop filter at a high flow rate. After a time period selected by the user, the filter is extruded from the air sampling head. It is then sealed, bar-coded, folded, and positioned in front of a germanium (Ge) detector. The Ge detector, in conjunction with its associated electronics and computer resources, analyzes the gamma rays in the filter. The gamma-ray spectrum and the radionuclide composition report are automatically transmitted to the appropriate organizations. Because the bar-code information is included in all spectra files

and reports, filters determined to be of special interest can be identified and manually retrieved for subsequent confirmatory analysis.

To achieve the desired ultrahigh sensitivity to fission products, the sampler portion of the system continuously separates particulate radionuclides from the atmosphere at a flow rate of 25,000 m³/day. With this flow rate, the analyzer is sensitive to as little as 2 μBq/m³ of radionuclides of particular interest (⁹⁹Mo, ¹⁴⁰Ba, and ¹³¹I) depending on the filter media chosen. The collected gamma-ray spectra and radionuclide concentration are transmitted by an automatic, network file transfer to designated organizations. The analyzer supports two-way data connections using networks, phone modems, and satellite modems. If desired, even greater sensitivity to certain radionuclides

Above photo: Prototype of Particulate Radionuclide In-Situ Analyzer.

can be achieved by specifying that the analyzer run in the mode which allows each filter to decay before being counted by the Ge detector. This allows radon-related background to be greatly decreased. In any case, a final report is generated within 72 hours of the beginning of the sample draw.

To facilitate remote unattended operation, our analyzer is fully automatic and prepared for most power situations, including temporary power outages. All stages of filter manipulation and filter analysis operate without intervention and are remotely programmable. Unattended operation eliminates human error and labor costs. Also, because the filter is analyzed immediately in the field, the need for sample transport and routine laboratory analysis is minimized. Between 250 and 500 samples can be taken without restocking, depending on the mode of operation. To address the constraints of remote locations, the analyzer requires only 2.5 kW of power and measures a compact 0.9 m × 0.9 m. This is equivalent to the power consumption of



▶ **Figure 1.** The Particulate Radionuclide In-Situ Analyzer is seen deployed inside a small trailer.

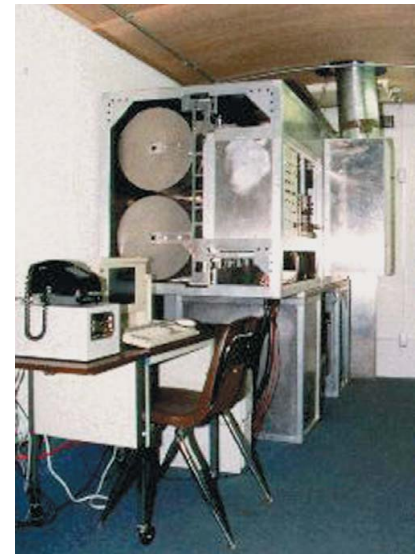

two common hair dryers and the size of a chest-type freezer.

A six-month battery of field tests is preparing the system for actual field use. Continued laboratory optimization studies and field prototype designs will continue through October 1996 (Fig. 1). ❁

CONTACT: **Harry Miley**
Pacific Northwest National Laboratory
PHONE: 509-376-3546
FAX: 509-373-0672
EMAIL: hs_miley@pnl.gov



Ultratrace-Level, Organic Chemical Analysis (ST217)

Our objective is ultrasensitive (sub-parts-per-trillion), chemical-analysis technology to identify organic chemicals from complex air samples. While we are centering our efforts on laboratory-based capabilities, we are also developing ideas for real-time analyses in the field. Identifying trace levels of organic chemicals in the environment is particularly challenging due to the large numbers and high levels of ambient background chemicals. Specific chemicals of interest may be present at sub-parts-per-trillion levels in a mixture containing thousands of ambient chemicals at hundreds of parts per million. Rigorous analytical approaches that collect sufficient target chemicals and selectively separate them from the background matrix prior to final analysis and identification are essential to confidently identify trace chemicals. We are developing large-volume air sampling (in 10²s–100³s m³ volumes), supercritical fluid extraction, and multidimensional chromatographic separation for information-rich detection techniques, such as mass spectrometry and infrared spectroscopy.

Ground-based and aircraft-based large-volume air samplers were developed and subjected to limited proof-of-principle evaluations. The air samplers collect and concentrate organic chemicals and particles on porous adsorbent materials from air volumes up to several hundred cubic meters at rates ranging from 0.5 to

4 m³/minute. The flow and adsorption characteristics for specific sampler configurations and chemicals of interest were determined to optimize sampler performance. We focused on developing highly permeable samplers, e.g., low pressure drop, for rapid sampling with relatively lightweight equipment. Supercritical fluid extraction rapidly and efficiently removes the chemicals of interest from the adsorbent beds for subsequent analysis. This approach allows near universal extraction of thermally labile, highly volatile, and less volatile chemicals that can be analyzed by gas chromatography. In addition, this approach is compatible with on-line analysis methods in which the chemicals are directly transferred to the next step in the analysis approach.

The highly complex mixtures resulting from large-volume air sampling are simplified and specific chemicals are isolated for multidimensional chromatography. A nearly multiplicative relationship exists in the separation power of two individual chromatographic separation stages coupled together compared to the separation power of each individual separation stage. Various chromatographic techniques can be coupled with specific combinations, offering certain advantages and challenges. We developed and evaluated several multidimensional chromatography prototypes based on microcolumn and packed-liquid chromatography (LC), high-resolution gas chromatography, and various coupling interfaces.

Above photo: The ultratrace-level analysis station in the laboratory.

Figure 1 shows a promising system that isolates relatively non-polar chemicals from complex air matrices. The packed-column, reverse-phase liquid chromatography stage fractionates the air sample into simpler fractions based on the hydrophobicity of the chemicals. This type of separation is particularly useful when isolating less polar chemicals, as many ambient contaminants in the environment are also less polar. The packed column allows large quantities of complex extract to be fractionated, which enhances sensitivity, but the higher solvent flow volumes of the packed column (as compared to a smaller column) make the interface to the capillary gas-chromatography column more challenging. Reverse-phase liquid chromatography interfacing is also more challenging as highly polar and less volatile solvents, such as water, are used. Specific fractions containing the chemicals of interest are then transferred through an interface to the high-resolution gas chromatography stage where individual chemicals can usually be isolated. These individual chemicals are then detected by ion trap mass spectrometry, providing structural information that confirms the chemical's identity.

Figure 2 demonstrates the capability of the above system. The extract from a 100-m³ air sample was fractionated by reverse-phase liquid chromatography. The fraction containing trace levels of combustion-product pollutants, phenanthrene and anthracene, was further separated by capillary gas chromatography with mass spectrometry detection. Only a narrow elution window with a selected ion plot of m/z 178 is shown, but several hundreds of compounds were isolated from the various liquid chromatography fractions. The detection limit for these two chemicals was approximately 0.7 parts per trillion. The average concentration of the background chemicals was approximately 1 part per million, with the overall mixture containing over 300 parts per million of organic contaminants. Consequently, chemicals were detected by this instrument when they were present at levels a million times lower than the hundreds of back-

ground chemicals. When the extract was analyzed by traditional gas chromatography/mass spectrometry, as shown in the bottom trace of Fig. 2, the target chemicals were undetectable. ❁

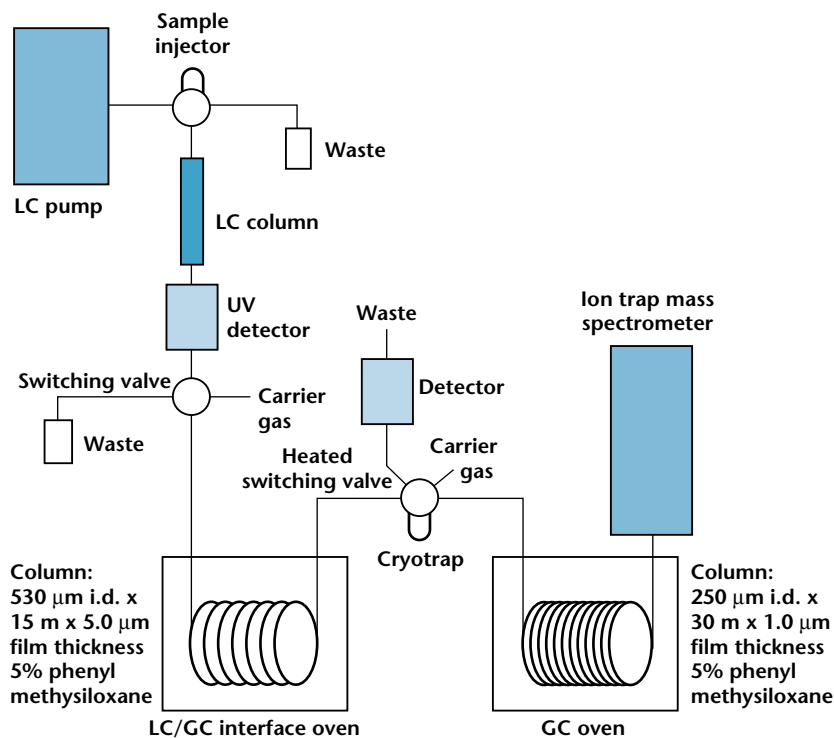

Figure 1. The schematic shows the new analysis station that isolates non-polar chemicals from complex air matrices.

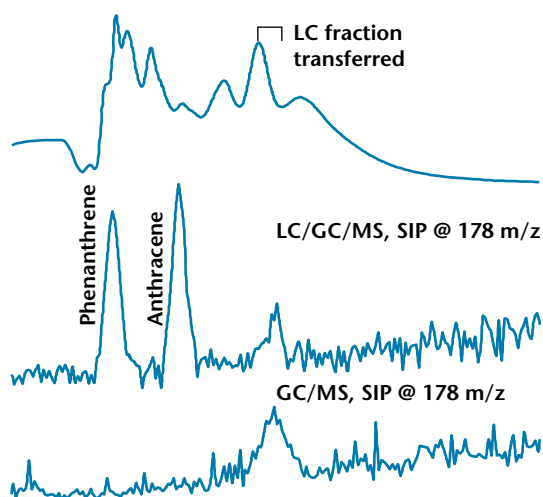

Figure 2. The results of a test of the new system show a detection limit of 0.7 parts per million for the chemicals indicated, but traditional gas chromatography/mass spectrometry did not detect the chemicals.

CONTACT: **Bob Wright**
 Pacific Northwest National Laboratory
 PHONE: 509-376-1661
 FAX: 509-376-5021
 EMAIL: bw_wright@ccmail.pnl.gov



Automated Nuclear Track Characterization (PL006)

We are designing and building an automated system to scan samples under a microscope and locate objects of interest, characterizing these objects and marking their locations. The system is tuned to search for an object (or cluster of objects) on the sample slide. The object of interest must have good contrast from the background as well as have features (e.g., shape, orientation, size, etc.) different from the other objects on the sample slide. Automatically locating, characterizing, and marking these objects allow us to prioritize subsequent analyses of the samples. Our current effort is focused on locating and marking nuclear-fission track clusters on solid-state polycarbonate detectors.

This technology has numerous potential applications including arms control verification, cell analysis, environmental monitoring, industrial inspection, and medical

diagnostics. The successful implementation of this technology will result in reduced time, labor, and cost as well as improved quality control.

Solid-state nuclear track detectors have been used for over 30 years in several scientific areas, including nuclear physics, health physics, and geology. Samples are collected, reduced, and applied to the detector surface. Permanent damage sites are created near the surface of the detector as induced charged particles emanating from fissile sources contained in the sample pass through the dielectric material of the detector. During chemical etching of the detector, these damage sites are amplified. The resulting dark track clusters on the transparent detector background provide good contrast when viewed through an optical microscope. Information about the sample is obtained by scanning the detector for these damage sites. When a large num-

Above photo: Pacific Northwest National Laboratory's automated system for characterizing nuclear tracks.

ber of samples needs to be processed, the length of time and labor required to scan the detectors and mark the tracks becomes a bottleneck. Manual scanning and marking are labor-intensive, fatiguing activities. Our automated scanning and marking system addresses this need to reduce the time, labor, and cost.

The system includes an optical microscope, a high-resolution digital camera, a motorized precision xyz stage and controller, a video-based auto-focus system, and image processor and computer workstation. The xyz stage scans a batch of 10 detectors under the microscope to acquire low-magnification, digital images of the entire surface of each detector. The video-based, auto-focus system maintains focus during the scan. Each image is transferred from the camera to the image processor in the workstation. When an object of interest is found, a high-magnification image is acquired, centered on the location of that object. This two-step approach increases the throughput of the system by quickly eliminating areas of the detector that contain no valuable information. If analysis of the high-magnification image verifies that the object is indeed of interest, then it is characterized and placed into one of eight categories. This helps to prioritize subsequent sample processing by dividing the objects into groups of similar attributes. Marking tools automatically mark the location of the objects with the appropriate classification codes (Fig. 1).

The code we are developing for the image processor uses commercial image-processing libraries and artificial neural networks (ANNs). We have generalized the software design so that it may be useful for other applications requiring the scanning of surfaces for other types of objects. Thresholds and constants required to find the specific objects are maintained in a "System Information" file. This information may be tuned to search for other objects without rewriting the processor code.

Low-magnification images are analyzed to quickly find objects of interest in the acquired image field. This minimizes the amount of surface area requiring high-magnification scanning. Following filtering

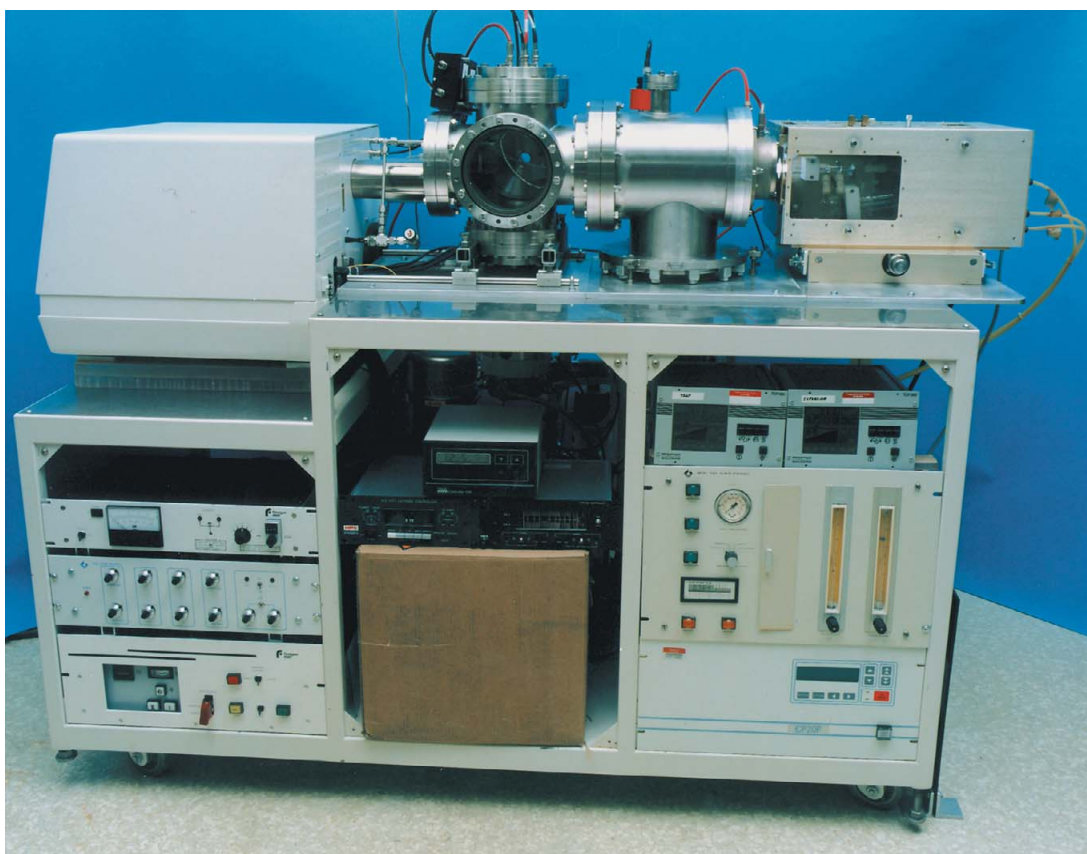

 **Figure 1.** Marking tools automatically mark the location of an object after analyzing a high-magnification image of the object.

and contrast enhancement of the low-magnification image, each picture element (pixel) is thresholded and converted to a white or black pixel (binary image). Adjacent groups of black pixels on the white background are defined as objects. Several measurements are made of each object to segregate them from the background noise and other artifacts. Measurements from objects of interest are preprocessed and used as inputs to an ANN. The ANN has been taught to distinguish objects of interest from other objects by training it on a presorted set of data. High-magnification images are acquired of the objects considered to be of interest by the ANN. Analysis of the high-magnification images determines whether or not an object is of interest. If so, the object is characterized and placed into one of the various object categories.

Installation of equipment in an end-user's lab is planned for the end of FY95, and activities for FY96 include debugging, testing, and evaluating the system at the end-user's site. ❁

CONTACT: Brion Burghard
Pacific Northwest National Laboratory
PHONE: 509-375-2481
FAX: 509-375-3614
EMAIL: bj_burghard@ccmail.pnl.gov



Ion Trap Inductively Coupled Plasma Mass Spectrometer [IT-ICP/MS] (ST392)

We are developing new, ultrasensitive instruments for the detection, monitoring, and analysis of chemical elements and isotopes indicative of nuclear-materials processing and related activities. Currently, detection and monitoring depend on covert or overt field sampling and subsequent laboratory-based analysis using powerful yet cumbersome mass spectrometers. A new type of mass spectrometer—a quadrupole ion trap, which is still under active development—offers advantages over conventional instruments. As its name implies, an ion trap captures and accumulates constituent ions of interest, thus separating and concentrating trace constituents from a preponderance of extraneous and undesired matrix constituents. Our project is directed at

combining an inductively coupled, plasma ionization source with an ion trap mass spectrometer.

We have built two plasma-source, ion-trap instruments, shown schematically in Fig. 1. The first instrument used off-the-shelf, commercial components as a base for feasibility testing and proof of concept. The results were extremely encouraging, with excellent sensitivity and more easily interpretable results. In particular, this instrument was successful in destroying or reducing previously problematic interferences and background in the mass spectra of analyte ions. On the basis of these results, we built a second-generation, direct plasma-to-trap instrument that combined the same analytical advantages with a smaller size. Both instruments exhibit a detection

Above photo: The second-generation prototype of the Ion Trap Inductively Coupled Plasma Mass Spectrometer (IT-ICP/MS).

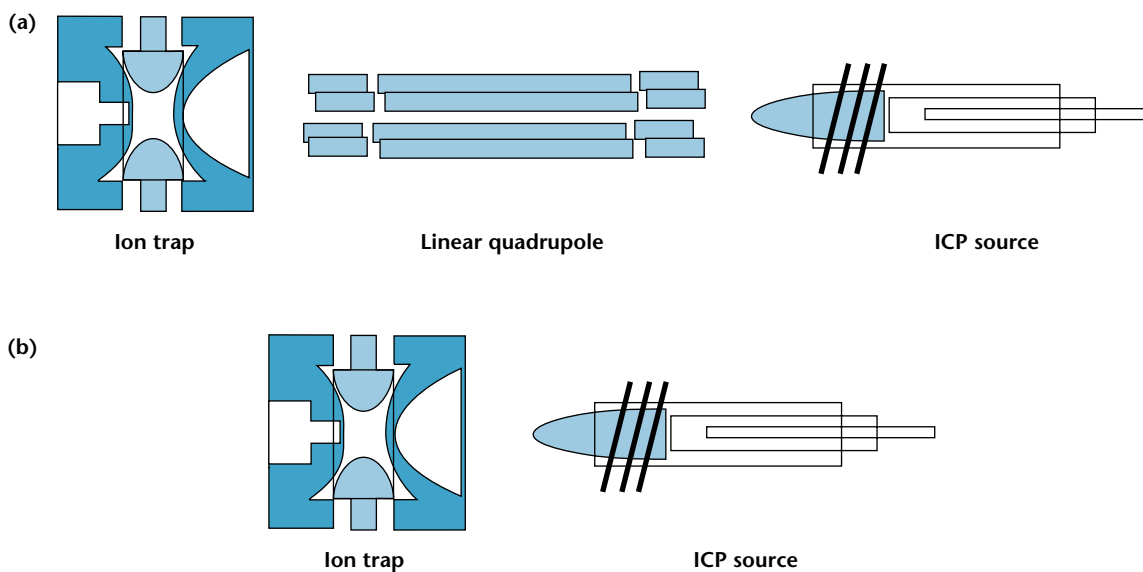

Figure 1. The top portion (a) shows the first plasma-source ion trap instrument. The bottom portion (b) shows the second-generation, direct plasma-to-trap design.

sensitivity of about 10 parts per trillion (pg/g of sample) for actinide isotopes.

The Ion Trap Inductively Coupled Plasma Mass Spectrometer (IT-ICP/MS) is about the size of a desk and is amenable to portable operation. With future developments and upgrades, an even smaller instrument package is possible. The IT-ICP/MS contains an atmospheric pressure ionization source that operates using readily available argon gas, providing nearly complete ionization of every element in the periodic table.

While these instruments are not completely competitive with existing technologies, results to date indicate that improved analyte sensitivity and system size reduction can be achieved. Overall, the work has been very successful, with a new instrument concept that provides a strong base for

further investigations and development. Demonstration of the concept has attracted industry attention and a Cooperative Research and Development Agreement has been set up with Finnigan Corporation (San Jose, CA) under the Department of Energy's Technology Transfer Application Office to facilitate commercialization. This effort is focused on developing a commercial instrument by 1997, with potential production planned for 1997–1998. ❁

CONTACT: **Dave Koppenaal**
 Pacific Northwest National Laboratory
 PHONE: 509-376-0368
 FAX: 509-376-5021
 EMAIL: koppenaal@pnl.gov



Nondestructive Determination of Particulate Composition (ST801B)

Quantitative elemental and isotopic analyses of overtly or covertly collected particulates provide intelligence and treaty-verification information crucial to monitoring nonproliferation. Of particular importance are the nondestructive identification and quantification of particles in various collection media (such as filters) on a quick turnaround basis. Sandia National Laboratories and Lawrence Livermore National Laboratory are developing an imaging and analysis system to rapidly determine the elemental and isotopic composition of micron-scale particulates. The system uses a high-energy, focused ion beam to rapidly scan across a sample in small steps (pixels). As ions transfer their energy to the electrons surrounding an atom, electrons become excited and some emit x rays as they return

to the ground state. Each element of the periodic table has a characteristic x-ray signature. By measuring the spectrum of x-ray energies and intensities produced during the ion beam scan, both the location of each particle on a filter and the elements present in each particle are identified. This technique—Particle-Induced, X-ray Emission (PIXE)—is an extremely sensitive probe for trace elements. In some instances, levels as low as a few hundred parts per billion can be detected.

Locating and analyzing micron-scale particles on large-area collection media in a timely manner is challenging. For example, locating a 3-micron particle (the diameter of a human hair is about 100 microns) on a 1 cm² filter is analogous to searching for and finding a quarter lost on a football field. The analysis strategy used by PIXE has two

Above photo: The analysis laboratory where the Particle-Induced, X-Ray Emission (PIXE) technique is being developed.

phases: (1) rapid location of particles of interest and (2) intense analysis of individual particles. In the first case, a high-current, “large” (100 to 200 micron) ion beam scans across a filter (Fig. 1). High ion currents ensure that a sufficient number of characteristic x rays are produced so that pixels containing particles of interest can be found and flagged for later analysis. High ion currents can cause localized damage to the collection media unless certain precautions are taken (such as measuring in helium rather than in a vacuum).

In the initial scan, there are tradeoffs between using large pixels, which allow higher beam currents but lead to greater background levels in the acquired x-ray spectra, and smaller pixels, which have higher signal-to-background ratios but may yield more sample damage. Part of our current research examines these tradeoffs in detail to formalize the most optimal analysis procedure. After the initial scan is complete, pixels previously flagged are re-examined, this time in a vacuum with a smaller (10 to 20 micron) beam and at a lower ion current. This second scan allows individual particles within a pixel to be distinguished. In the final step, intense elemental and isotopic analyses of individual particles are conducted with a fixed 1- to 2-micron beam. PIXE identifies a particle’s elemental composition while an analogous technique, Coulomb excitation (which detects emitted gamma rays), measures isotopic enrichment.

No molecular interferences, sample matrix effects, or isobaric confusion are common in mass spectrometry because ion beam analysis is based on the energy analysis of characteristic x rays and gamma rays. Because the complete analysis is conducted directly on the collection medium, no labor-intensive and time-consuming “particle picking” or extensive sample preparation is needed. Rapid PIXE scans can identify all elements heavier than sodium simultaneously and provide their locations within minutes. Elemental analysis of individual particles can be conducted within a few seconds for weight-percent concentration levels.

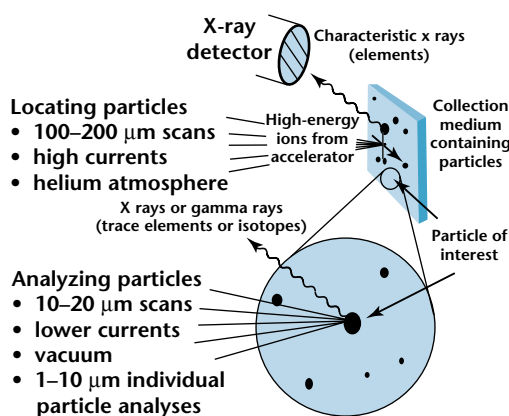

Figure 1. The Particle-Induced, X-ray Emission (PIXE) techniques rapidly locates micron-sized particles and flags them for later analysis.

We demonstrated the PIXE system recently on a test filter prepared by the National Institute of Standards and Technology (NIST). We had no information regarding the particle composition or loading on the filter prior to the measurement. After the analysis was complete, the results were compared to the actual particle distributions supplied by NIST. The filter had been loaded with 1- to 10-micron particles from two different, uranium-containing glasses, a maraging steel, a glass containing intermediate atomic number elements, and hexagonal boron nitride. PIXE not only successfully identified and quantified all major elements present on the test filter, but it also determined the exact correlations between different elements and specific particle types. The only exception was boron nitride, which could not be observed because the technique is not sensitive to the very low energy x rays produced by light elements. The success of this demonstration has led to the future development of a compact, ion beam imaging and analysis system that will be cost-effective, user-friendly, and have fast total analysis turnaround time. ❁

CONTACT: **Arlyn Antolak**
 Sandia National Laboratories
 PHONE: 510-294-3363
 FAX: 510-294-3231
 EMAIL: antolak@sandia.gov



Particle Separations by Capillary Electrophoresis (ST381)

The objective of this project is to develop Capillary Electrophoresis (CE) methods to separate uranium-oxide (UO_2) particles from other kinds of particles, thus significantly reducing the time and cost of isolating UO_2 particles present in samples of particulate materials. The procedure for identifying and isolating effluent particles such as those from uranium oxides is presently based on the labor-intensive and time-consuming lexan process. That process requires 4.5 work days on average to process a particulate sample. The time required depends directly on the amount of particulate material to be processed. A method is needed to separate and concentrate uranium-oxide particles with respect to the other sample particles. No available technique for separating UO_2 particles from other kinds of particles provides the required particle enrichment.

CE is a new and fast technique for separating chemically different kinds of particles from one another. Separations in CE are based on differing velocities of charged species traveling down a capillary tube while under the influence of an electric field gradient (Fig. 1).

CE is applied primarily to separating ionic species in aqueous solutions. Separations of particles in aqueous suspensions depend on differing surface charge densities on chemically different particles. Surface charges are generated by chemical reactions of particle surfaces with a suspending aqueous medium. Because essentially no information is available on particle separations by CE, it was necessary to determine the effects of CE's operating parameters on electrophoretic behavior and separations of various kinds of particles. We examined capillary dimensions, buffer solution condi-

Above photo: The Capillary Electrophoresis (CE) system.

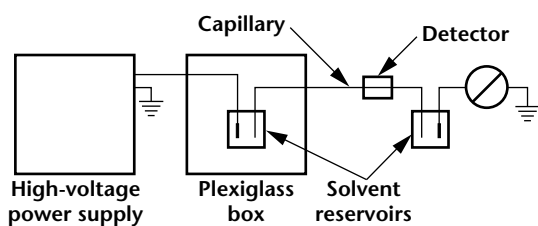

Figure 1. Schematic of the CE system shows the various parts of the system examined during the project.

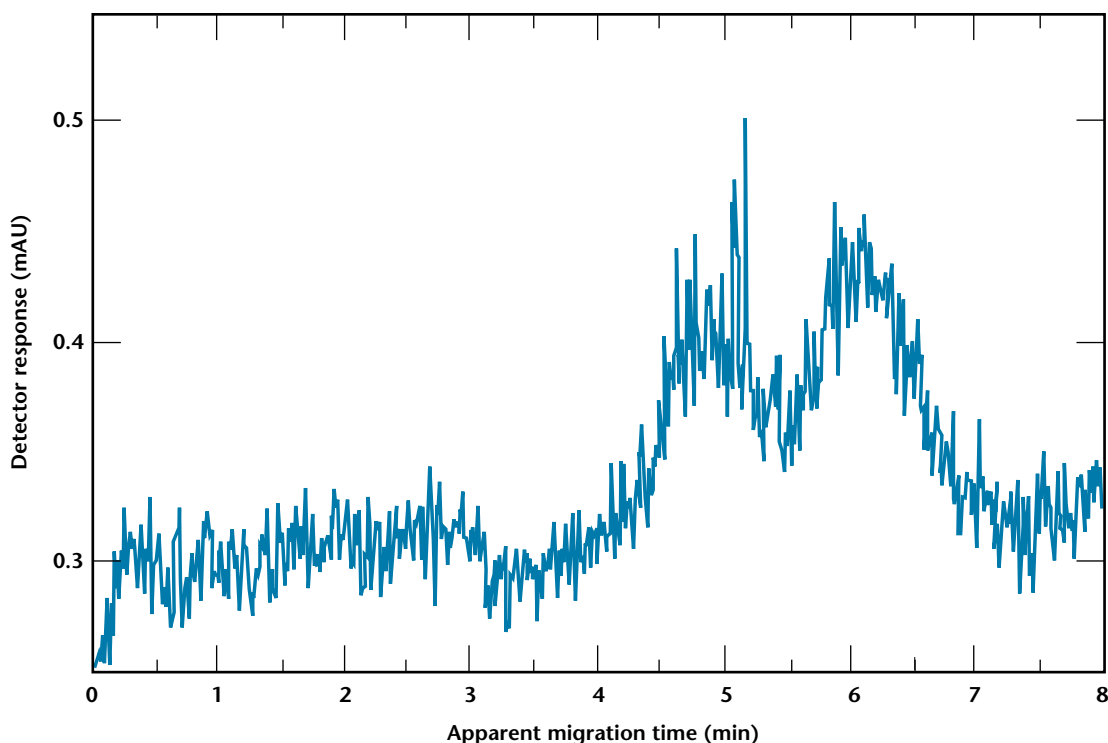

Figure 2. The graph shows the separation of uranium oxide (UO_2) particles from a mixture of particles from the environment.

tions, electric field strength, and surfactant use. In addition, we wanted to establish the conditions for generating satisfactory suspensions of particles for CE runs. The fused silica capillaries were 30–60 cm long with internal diameters of 75–100 μm . We evaluated buffer solutions of phosphate, borate, carbonate, and acetate and the effects of their concentrations and pH values on electrophoretic behavior. Electric field strengths were 100–500 V/cm. We also evaluated surfactant use for a limited number of cases.

We developed CE methods to rapidly separate chemically different kinds of oxide particles (e.g., Al_2O_3 , Fe_2O_3 , Fe_3O_4 , TiO_2 , and UO_2). We applied these methods to simple oxide particle mixtures and to complex mixtures of oxides and environmental particles. Separations of UO_2 particles from environmental particles are of

central importance to this project and were the focus of later studies. Such separations were successfully accomplished (Fig. 2).

We integrated a method for separating particles, collecting separated fractions, and determining UO_2 and environmental particles in the fractions. This method was applied to a mixture of UO_2 and environmental particles. Only 5% of the environmental particles were present in fractions containing about 80% of the UO_2 particles. Thus, an enrichment factor of 20 for UO_2 particles was attained. This degree of enrichment permits significant reduction in the time and costs of isolating uranium-oxide particles present in samples of particulate materials. ❁

CONTACT: **Nate Ballou**
Pacific Northwest National Laboratory
PHONE: 509-376-3601
FAX: 509-376-5021
EMAIL: kr_chase@pnl.gov

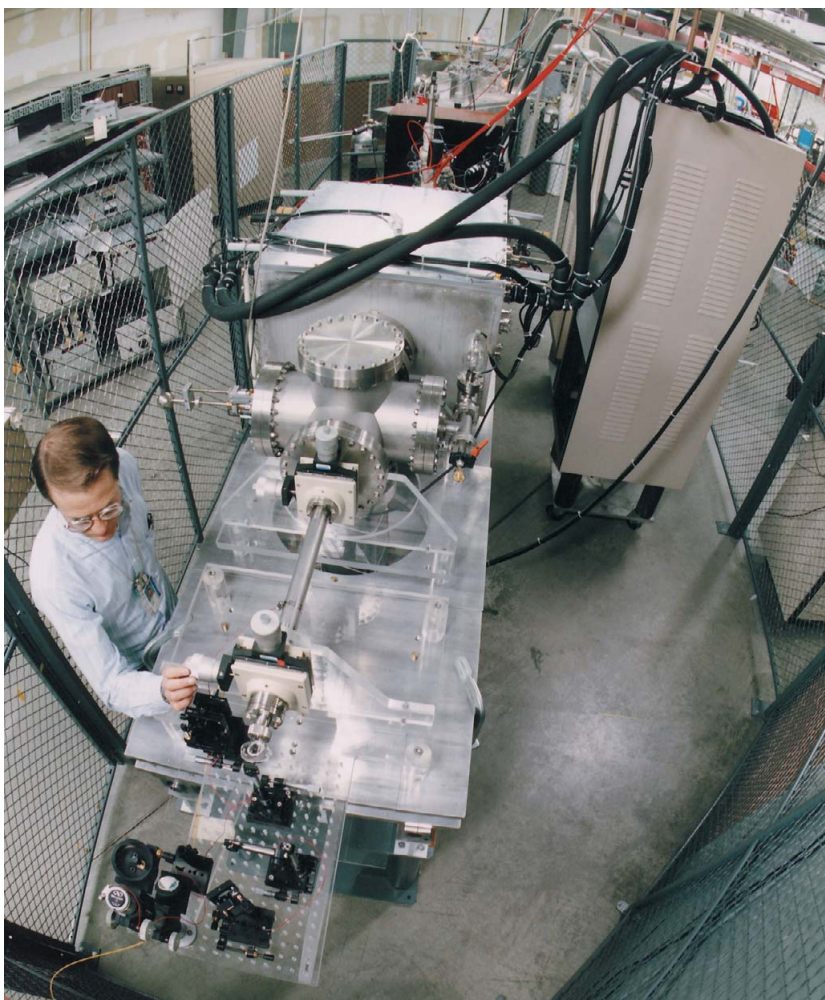

Photon-Burst Mass Spectrometry (ST104)

We are developing a technique to measure noble-gas isotope ratios in the 10^{-9} to 10^{-14} range using a magnetic-sector mass spectrometer and photon-burst detection of the exiting ions. We developed a clean and efficient ion source and interfaced this to a dynamic-gas mass spectrometer (separator) developed by our collaborators at Colorado State University (CSU); we also installed a multiple-collector detection apparatus. CSU developed the prototype photon-burst detector for noble-gas ions as well as the charge exchange cell. The detector and spectrometer have recently been integrated and measurements in the 10^{-9} range are now possible.

Above photo: Detection-end of the Photon-Burst Mass Spectrometry apparatus, used to measure ^{85}Kr at ambient levels.

Several factors limit the ranges of measurable isotope ratios. Ionization efficiency and throughput limit the total number of ions of the minority isotope that can be generated in a useful period of time. Additionally, the separation of isotopes is not perfect; instruments having finite throughput always leak (when the major isotope corresponding to the minor isotope appears in the signal channel). Leakage normally limits the range of measurable isotope ratios to 1:10⁶. This range is insufficient for many applications; in addition, in conventional mass spectrometry, isobaric interferences (for example, ^{84}KrH interfering with ^{85}Kr) can completely obscure the desired signal. Our instrument circumvents this problem by using a highly

selective detector at the terminal end of the instrument. A fluorescence-based, photon-burst apparatus selects the minority isotope.

Photon-burst mass spectrometry combines mass spectral separation and laser-based selective detection to provide isotope-ratio measurements at high dynamic ranges. A magnetic separator, used to produce a high-energy ion beam of the minority isotope, precisely measures the majority isotope. The minority isotope is then decelerated, and passed through a charge-exchange cell to produce atoms in a selected quantum state. These atoms are then subjected to fluorescence photon-burst detection, in which each atom undergoes repetitive absorption/emission cycles to produce a burst of photons. These bursts are detected, and the burst size is used to discriminate between real detection events and background (dark signal, scattered light, etc.). In addition, the particles pass through a series of independent detectors. Advantages of photon-burst detection over conventional particle counting include no isobaric interferences, multiple detection of each particle, artificial Doppler shift, and time-correlated detection.

Our high efficiency of detection and complete lack of interference allow measurements of noble-gas samples. The novelty and relative unfamiliarity of this capability have so far limited its application to nuclear materials; however, tremendous potential exists for tracer experiments in exploring for oil and gas, monitoring global climate changes, and assessing the integrity of nuclear materials.

Recent measurements with krypton isotopes are particularly promising. We have measured $^{85/84}\text{Kr}$ isotope ratios on a sample containing ^{85}Kr at the 6×10^{-9} level; based on our signal-to-noise ratio in this analysis, we project our current level of detection to be $\approx 10^{-10}$. With the recent availability of higher efficiency detectors, we anticipate that the 10^{-11} – 10^{-12} range can be measured in a straightforward manner.

Photon-burst mass spectrometry is the only technique capable of providing specialized ^{85}Kr analysis, especially detecting small samples from clandestine sites. All proof-of-principle steps are proven in the integrated instrument. The next step is improving the detectors and demonstrating the implementation on “user” samples. It should be pointed out that this project addresses a non-trivial problem: a $1:10^{-12}$ measurement with limited sample size is a complex measurement problem. ☁

CONTACT: **Nick Nogar**
Los Alamos National Laboratory
PHONE: 505-665-7279
FAX: 505-665-4631
EMAIL: nogar@lanl.gov

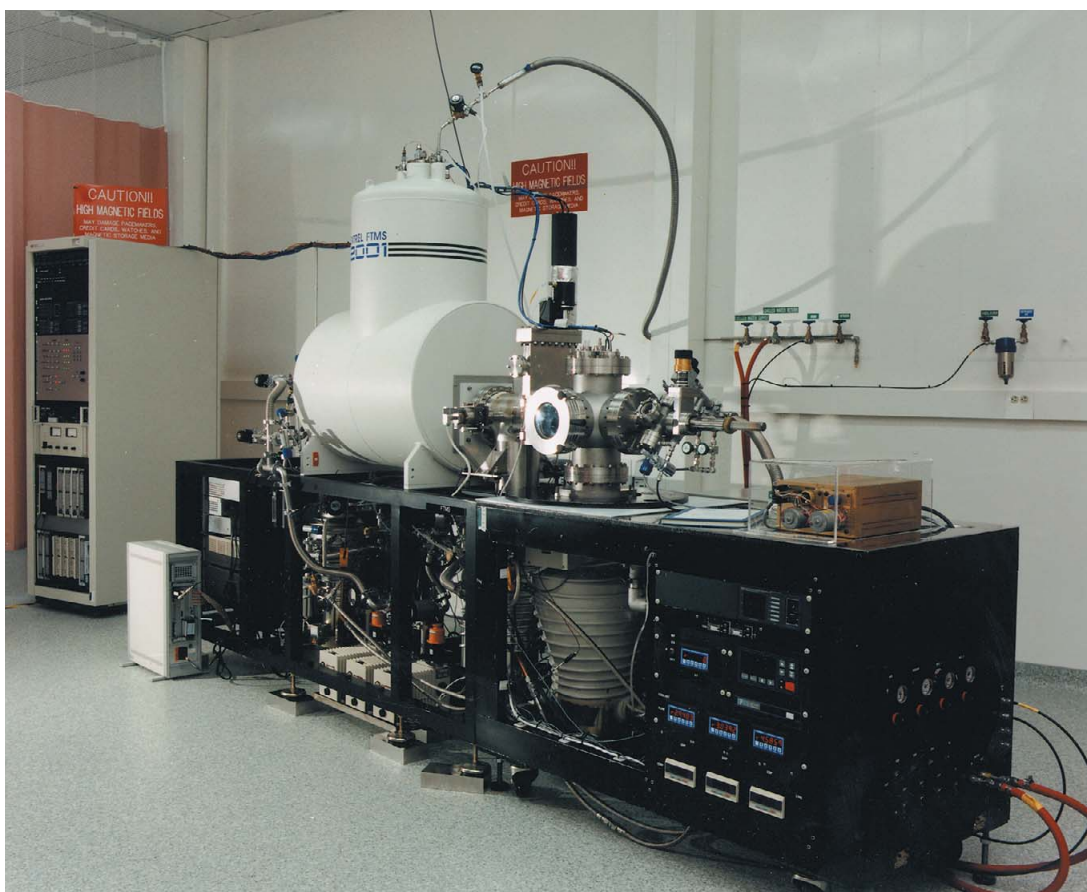

Radiofrequency Glow Discharge/Fourier Transform/Ion Cyclotron Resonance Mass Spectrometer (ST825)

We are developing a Fourier transform, ion cyclotron resonance mass spectrometer (FTMS) with an external, radiofrequency glow discharge (RF/GD) ion source to unambiguously identify and characterize proliferation signature compounds and isotopes. FTMS is the highest mass-resolving-power mass spectrometric technique, allowing for the exact identification of atomic or molecular species by determining their exact mass with sub-milli-atomic mass unit accuracies. The high resolution avoids the problem of interference of pseudo-isobaric species. The RF/GD ion source allows for the analysis of electrically nonconductive solid samples (e.g., soils).

Typical mass spectrometers have mass resolving powers of a few hundred to a few

thousand. This is insufficient to solve many of the signature problems. For example, resolving ^{238}Pu and ^{238}U requires a resolving power of 180,000; ^{99}Tc and ^{99}Ru requires 315,000; and resolving ^{129}I and ^{129}Xe requires a mass resolving power of 625,000. FTMS, which can easily obtain mass resolving powers in the 2- to 10-million range, can easily differentiate between these isotopes.

All mass spectrometers have three basic components or operations: ion formation, ion selection, and ion detection. In most mass spectrometers, these operations are separated in space. FTMS is unique in that these events occur in the same spatial region but are instead separated temporally. In FTMS, ions are formed in a strong magnetic field. Here, they orbit around the

Above photo: The Radiofrequency Glow Discharge/Fourier Transform/Ion Cyclotron Resonance Mass Spectrometer (RF/GD-FTMS).

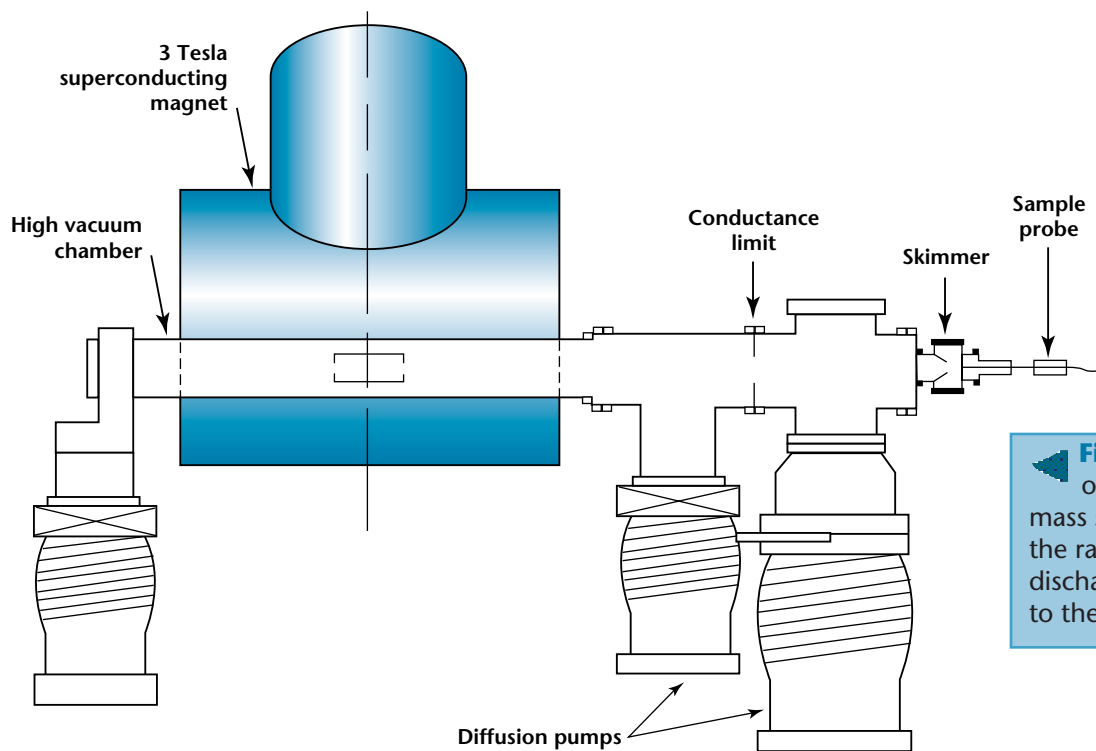

Figure 1. Schematic of the ion cyclotron mass spectrometer shows the radiofrequency glow discharge ion source external to the analyzer cell.

magnetic field lines. This motion, known as cyclotron motion, has a frequency inversely proportional to the mass-to-charge ratio of the ion. The ions are trapped in the magnetic field between two “trapping” plates perpendicular to the magnetic field. Ions are detected by pairs of excite and receive plates (which complete the sides of the box-like ion trap). The excite plates add energy to the ions while the receive plates have a signal induced in them at the same frequency as the cyclotron frequency. For single mass ions, this is a perfect sinusoidal signal, but for an ensemble of masses, a complex waveform is observed. This complex waveform (or transient) is digitized by a computer and undergoes Fourier transform analysis to determine the masses present and thus the masses in the analyzer cell. In FTMS, the measurement of the mass of an ion is reduced to a frequency measurement, and frequency is a physical property that can be measured with great precision, yielding the inherent mass accuracy of the FTMS.

RF/GD ion sources are excellent ways to ionize a variety of solid compounds. They have the advantage over direct-current glow discharge sources in that they are not limited to electrically conductive solid samples. However, these sources operate

under a pressure of a few millitorr of argon, so they cannot be directly interfaced to FTMS systems that require an operating vacuum six to eight orders of magnitude lower. To solve this problem, the Savannah River Technology Center (SRTC) instrument is designed with the RF/GD source external to the FTMS analyzer cell, allowing for the ion beam to be transferred to the cell through several stages of differential pumping. This allows for the FTMS to operate at the optimum vacuum, while having the advantages of the RF/GD ion source (Fig. 1).

Preliminary experiments conducted at Oak Ridge National Laboratory demonstrated that high-resolution mass spectra could be obtained in this manner. These experiments led to the SRTC instrument. This instrument was tested and some design changes were required to optimize ion transfer from the ion source to the ion cyclotron resonance analyzer cell. These changes were recently made, and the system is being prepared for the next round of tests. The instrument should be operational in FY96. ❁

CONTACT: **Bob Weller**
Savannah River Technology Center
PHONE: 803-725-9557
FAX: 803-725-4478
EMAIL: robert.weller@srs.gov

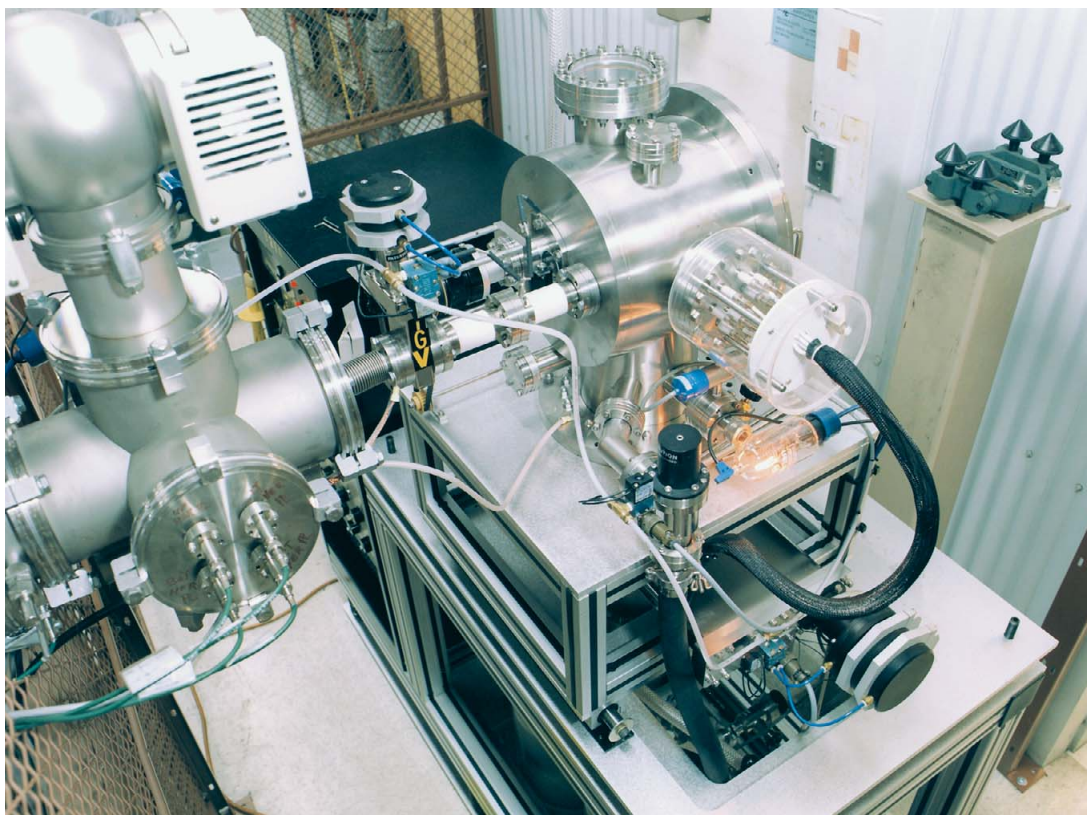

Thermal Emission Ion Source for Accelerator Mass Spectrometry [TEAMS] (ST224)

Most of the fission-product nuclide ^{129}I found in environmental samples is the legacy of atmospheric nuclear tests or the results from nuclear-fuel reprocessing. The amount of ^{129}I due to natural processes is very small because it is produced only by cosmic-ray bombardment or by spontaneous fission of naturally occurring heavy elements. Any enhancement above background levels indicates current nuclear activities. Thus, ^{129}I is a useful tracer for arms control and nonproliferation monitoring.

Accelerator mass spectrometry (AMS) is the most sensitive and selective analytical method for trace isotopic analysis. Our joint project between Pacific Northwest National Laboratory's (PNNL) small-samples processing laboratory and Lawrence Livermore National Laboratory's

(LLNL) Center for Accelerator Mass Spectrometry will provide even greater sensitivity for ^{129}I and certain other isotopes. Our ultimate goal is to analyze samples of a few tens of milligrams that have only a few hundred atoms of ^{129}I .

The only stable isotope of iodine is ^{127}I . However, ^{129}I with a half-life of 15.7 million years is produced in high yields by nuclear fission. The ratio of ^{129}I to ^{127}I is a key indicator of fuel reprocessing or other nuclear activities.

The small-sample processing laboratory at PNNL has much experience in measuring ^{129}I by thermal-ionization mass spectrometry. Sample preparation depends on the type of material to be processed. The purified sample is mounted on a rhenium filament which is then placed in the ion source of a three-stage mass spectrometer.

Above photo: View of part of the injection system and the thermal emission ion source of the accelerator located at Lawrence Livermore National Laboratory.

Gentle heating of the sample filament vaporizes the iodine which then comes in contact with a specially treated second filament. The treated filament provides a high probability of forming negative iodine ions. These ions are then extracted by an electric field of about 8 kV and are analyzed by the mass spectrometer. The detection limit with this instrument is about 10^7 atoms of ^{129}I . With about 2 mg of iodine loaded onto the filament, isotopic ratios of $^{129}\text{I}/^{127}\text{I}$ as low as 10^{-9} can be measured.

A commercial thermal emission ion source was purchased and installed on a new beam line on the low-energy end of the accelerator (Fig. 1). This beam line sends negative ions of iodine into a dipole magnet that bends the beam 90° to inject the beam into the accelerator. The dipole magnet has rotatable pole tips that allow negative beams from the sputter ion source located 180° opposite the thermal ion source to inject into the accelerator when the thermal source is not being used.

The negative ion source routinely used for AMS measurements is a cesium sputter ion source. Typically, sample sizes with this source are about 1 mg of iodine. The joint PNNL-LLNL program enabled the analyses of much smaller samples of a few tens of milligrams. We chose to combine the high sample efficiency of the thermal emission ion source with the high isotopic ratio sensitivity of the AMS system. The project is called TEAMS because it couples a Thermal Emission ion source to Accelerator Mass Spectrometry.

Some samples, such as sea water, have abundant iodine and consequently $^{129}\text{I}/^{127}\text{I}$ isotopic ratios are below the sensitivity limit of mass spectrometry. Fortunately, AMS can measure $^{129}\text{I}/^{127}\text{I}$ isotopic ratios as low as 10^{-14} . This technique injects the negative iodine ions into a Tandem Van de Graaff accelerator. The high-voltage terminal of the Tandem accelerator has a gas stripper that converts the I^{-1} ions to I^{+5} ions. With the terminal operating at about 3.2 MV, the final iodine energy is about 19 MeV. This high energy allows a time-of-flight and total-energy-counting technique to remove impurities in

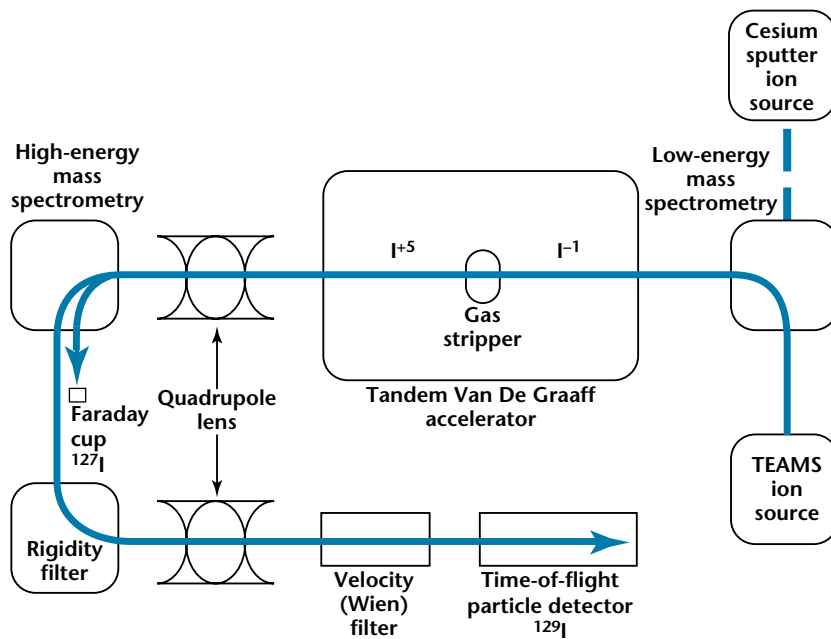
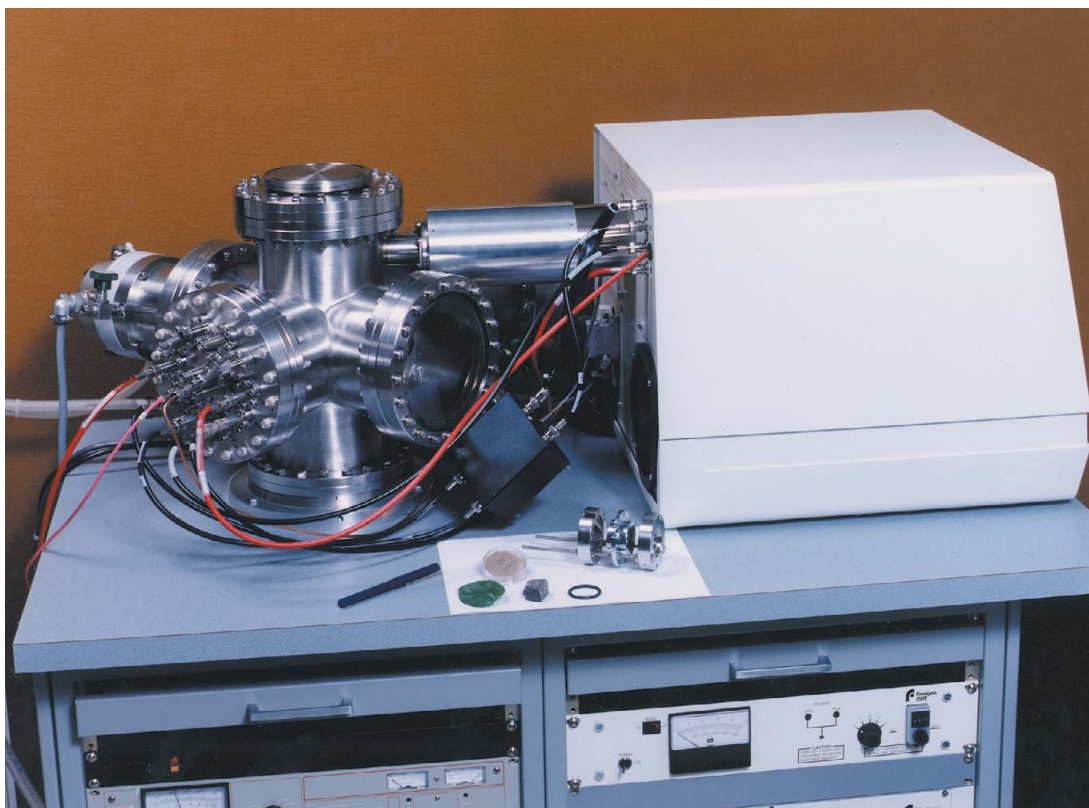

Figure 1. The accelerator mass spectrometry system is shown configured for iodine isotopic ratio measurement using the TEAMS ion source.

the mass 129 ion beam. In addition to measuring very low isotopic ratios, the AMS technique is significantly more tolerant of impurities remaining after the chemical preparation steps.

We have begun testing the new TEAMS. Ions from standard samples of ^{127}I with minimal ^{129}I have been extracted from the ion source, bent 90° , injected into the accelerator, and have been detected after the first of the two dipole magnets at the high-energy end of the accelerator. At this time, the measured beam currents have been too small to perform isotope ratio measurements; however, we expect large increases in the beam currents from the TEAMS ion source as we gain more experience with the source in its new configuration. ❁

CONTACT: **Paul Reeder**
 Pacific Northwest National Laboratory
 PHONE: 509-376-0948
 FAX: 509-372-0672
 EMAIL: pl_reeder@pnl.gov



Trace Detection on Surfaces by Secondary Ion Mass Spectrometry (IL032)

Secondary Ion Mass Spectrometry (SIMS) rapidly and directly detects extractant chemicals and their decomposition products, the chemical signatures of the nuclear-weapons production cycle. An example is tri-n-butyl phosphate (TBP), used for extracting plutonium, uranium, and other metals from nitric-acid processing solutions. TBP is sufficiently volatile to easily pass into the gas phase under ambient conditions, but it is very difficult to detect in atmospheric samples at low concentrations because TBP strongly adsorbs to surfaces, particularly metal. Thus, substantial quantities can build up on surfaces, facilitating detection by trace SIMS and hindering detection by gas sampling. TBP also undergoes radiolytic, acid-catalyzed, and base-catalyzed decomposition to dibutyl phosphoric acid, monobutyl phosphoric acid, and octyl dibutylphosphate.

These three can be more specific signatures of the nuclear-weapons production cycle. Because of the extremely low levels of analyte expected, and the need for a high degree of confidence in the analytical measurements, high sensitivity and excellent specificity are primary requirements. To attain these, we are developing an ion trap mass spectrometer (ITMS)-based SIMS instrument.

The SIMS instrument has a unique geometry that optimizes insertion of secondary ions into the primary ion trap, making for a very compact system; the primary ion gun, ion trap, detector assembly, and sample are all collinear. We are modifying a Finnigan ITMS (Finnigan Corp., U.S.) and a Teledyne 3DQ (Teledyne Electronic Instruments, U.S.). The primary ion beam is directed onto the sample continuously during ionization, and

Above photo: Secondary Ion Mass Spectrometry (SIMS) instrument.

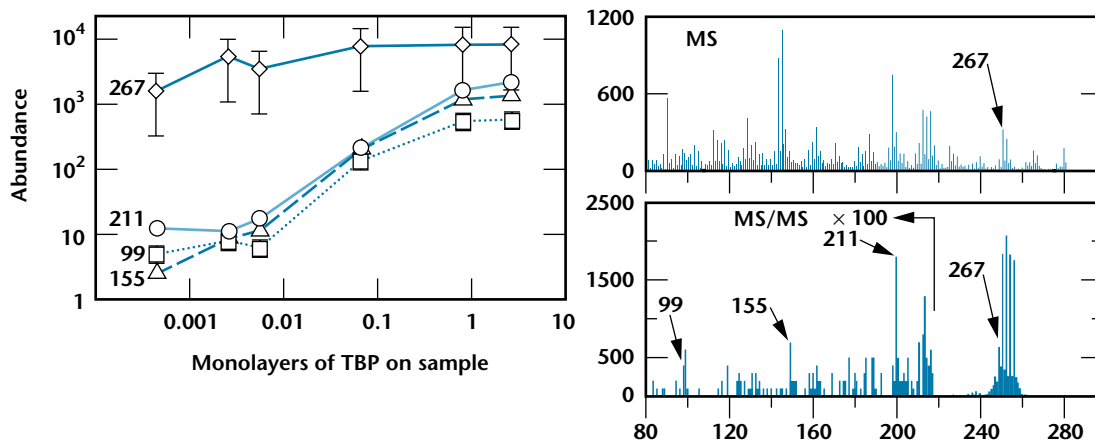

Figure 1.
Measured intensities of the molecular ion of tri-n-butyl phosphate (m/z 267) and the MS/MS fragment ions m/z 211, 155, and 99 as a function of the fractional monolayer coverage of tri-n-butyl phosphate on soil.

the secondary ions are collected in the trap during this period. Once an adequate number of secondary ions is accumulated in the trap (typically 5–50 ms), the primary beam is shut down (electrostatically) and the ions in the trap can then be reacted, excited, cooled, dissociated for MS/MS, and scanned out for detection.

The primary limit to trace-level detection using static SIMS is the abundance of “chemical noise” in the mass spectrum; that is, a peak at every mass arises from the presence of hydrocarbons, siloxanes, and other semi-volatile compounds. This noise is overcome using MS/MS to interrogate the structure of the ion. Figure 1 summarizes the detection of TBP on soil. The molecular cation of TBP is at m/z 267, and MS/MS daughter ions result from elimination of one, two, and three butenes. Note that the slope of the m/z 267 signal (containing TBP + isobaric background ions) is much flatter than that of the TBP daughter ion signals, illustrating that, at low TBP levels, the majority of the signal at m/z 267 is not TBP but isobaric ions. The MS/MS efficiency is ~50%, and applying this to the 0.01 monolayer data shows MS/MS can unequivocally identify the TBP molecular ion even when it is less than 1% of the total counts in the m/z 267 peak.

Figure 1 also shows that the minimum detection level for soil corresponds to the equivalent of a 0.01–0.005 monolayer of TBP on the surface of the soil, limited by the background level of TBP in our laboratory. Thus, it is possible to reduce the limit with appropriate sample-handling proce-

dures. Additionally, these results demonstrate that the specificity can be maintained even at the lower limit of detection, providing an extremely high level of confidence and minimizing the possibility of false-positive detection. Our experiments show that a wide range of samples exposed to dilute solutions and gas-phase TBP can be successfully analyzed with trace SIMS; these include soils, vegetation, polymers, metals, paper products, and a variety of chemically specific filter media. Additionally, trace SIMS typically requires 10 minutes when performing selected ion storage MS/MS, and requires only 1–2 mg of sample, as compared to standard chemical extraction techniques requiring grams. It may be possible to analyze material captured on filters that would be insufficient for traditional methods.

Paraffinic amines and the full range of organophosphate compounds that result from the exposure of TBP to a radiation field are also readily detected using SIMS. This is very encouraging as these are the more definitive signatures of reprocessing. We have also used the technique to detect the degradation products of nerve agents (methyl phosphonic acids) on vegetation. We are coupling SIMS with chemically selective, passive-sampling surfaces to detect target compounds in water and air at trace levels. ☼

CONTACT: Tony Appelhans
Idaho National Engineering Laboratory
PHONE: 208-526-0862
FAX: 208-526-8541
EMAIL: ada2@inel.gov

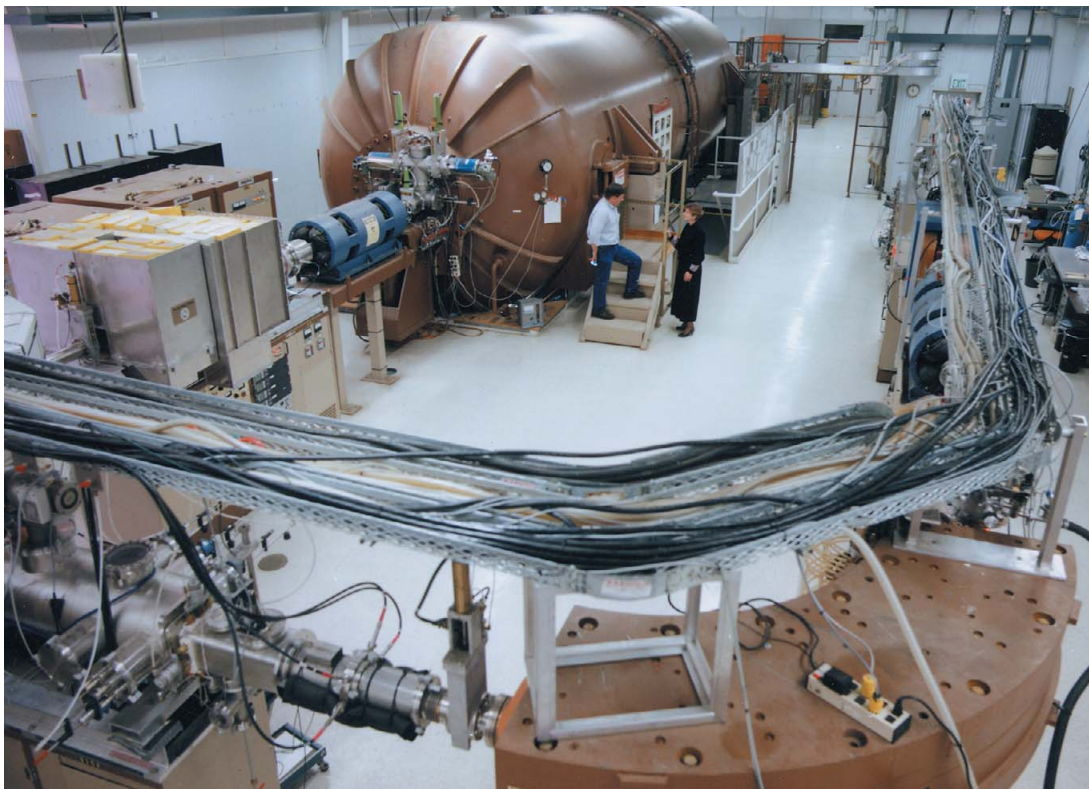

Ultratrace Techniques: Radioisotope Analysis with Accelerator Mass Spectrometry (ST801A)

Modern accelerator-based, analytical techniques can greatly increase the sensitivity of or reduce the sample sizes that need to be collected for isotopic analyses. These techniques offer new capabilities in the analysis of long half-life isotopic constituents. As few as 10^6 atoms of the isotope contained in a sample of 10–100 mg of the stable element may be adequate for measurement. Sensitivity gain may be exploited to reduce the volume of material necessary for analysis or to allow collection at a much higher dilution factor, hence further from or later than the event of interest.

Samples obtained by environmental monitoring techniques may contain very small amounts of a key signature isotope. These might include, for example, ^{14}C from reactor operations, or ^{36}Cl , ^{99}Tc , and

^{129}I from reactor-fuel reprocessing.

Detection of long-lived nuclides (half-life $\geq 10^3$ years) by conventional counting methods is difficult unless a large amount of material is available for high-resolution gamma counting, or the abundance of the radioactive isotope is much larger than environmental levels. Accelerator mass spectrometry (AMS) offers an increase of sensitivity between three and six orders of magnitude in the detection of some isotopes. The technique has been developed for the cosmogenic isotopes ^{10}Be , ^{14}C , ^{26}Al , ^{36}Cl , ^{41}Ca , and ^{129}I . Because of their low abundance in the atmosphere or ocean (typically $1:10^{12}$ – $1:10^{16}$), these isotopes can easily be detected at long ranges from the emitting site. Thus, analysis of environmental samples by AMS can be a key indicator of nuclear activity, either far from the

Above photo: The high-energy portion of the Accelerator Mass Spectrometry (AMS) facility at Lawrence Livermore National Laboratory (LLNL) occupies half of an 8,000 sq.-ft facility used for a variety of nuclear analysis and characterization techniques.

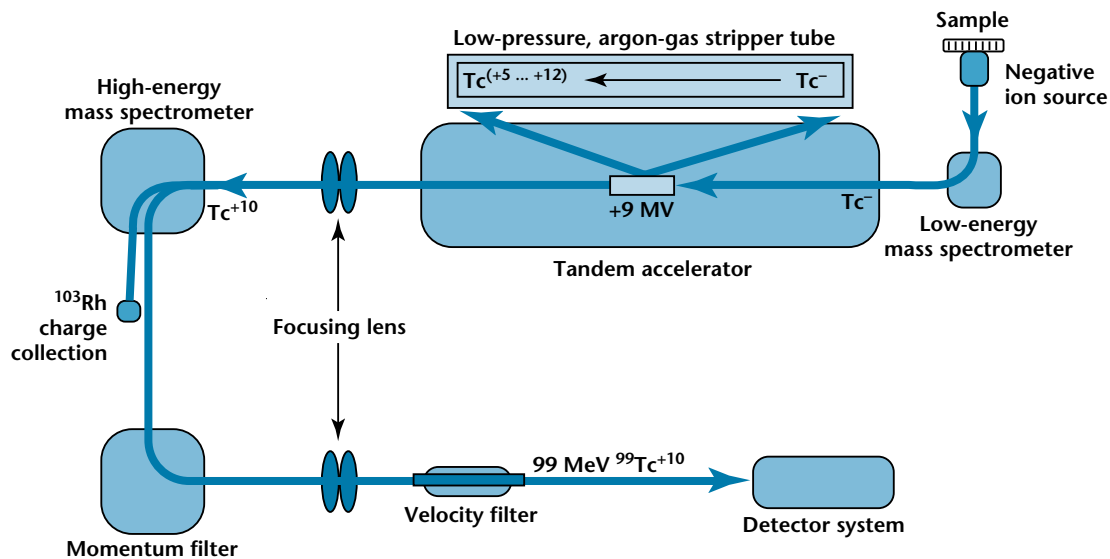

Figure 1. Schematic shows the complete Accelerator Mass Spectrometry (AMS) system.

emitting site or if masking countermeasures for isotopic signatures have been used.

Figure 1 is a schematic of the complete AMS system. Samples are placed in a 64-sample cassette on the back of the negative ion source. Samples are individually bombarded with a positive cesium beam as the first step. A few percent of the atoms in a sample gain an extra electron and are extracted as a negative beam from the ion source. The rare isotope, ^{99}Tc , shown in the schematic, and the tracer or stable isotope, ^{103}Rh , are sequentially switched into the tandem accelerator. This production and switching process is analogous to a conventional, low-energy mass spectrometer. The negative ions are accelerated to the positive terminal of the tandem accelerator. In the terminal, several electrons are removed from the ions by passing them through either a tube containing argon gas or a thin carbon foil. This stripping process breaks up all molecules that might interfere in the final analysis. The positive ions are then accelerated through the exit portion of the tandem accelerator and enter a high-energy mass spectrometer, which selects one charge state and a unique energy of the rare and tracer isotopes. The tracer isotope is measured by integrating

the charge deposited in a current-measuring cup. The rare isotopes proceed onward through a second momentum filter and a velocity filter, where they finally impinge on the detector. The detector system counts individual ions and determines total energy, the rate of energy loss, the ratio of energy to mass, and/or the characteristic x rays produced by the ions. Some subsets of these parameters uniquely identify the rare isotopes as they are individually counted. This complete selection and identification process is what allows AMS to identify rare-to-stable isotope ratios as low as $1:10^{16}$. Surprisingly, because the sample preparation is relatively simple and the analysis rapid, the analysis cost for AMS is often lower than that for other techniques used for ultratrace isotopic analysis. *

CONTACT: **Ivan Proctor**
Lawrence Livermore National Laboratory
PHONE: 510-422-4520
FAX: 510-423-7884
EMAIL: proctor2@llnl.gov

Department of Energy

DOE/S

Hazel O'Leary, Secretary

DOE/NN

Kenneth Baker
Anthony Czajkowski
Kenneth Luongo
George McFadden
John Nettles
Joan Rohlfing
Tom Ryder
Notra Trulock
Robert Waldron

DOE/DP

Everet Beckner
Roger Fisher
Liza Gordon-Hagerty
David LeClaire
Tara O'Toole
Victor Reis
Thomas Stitl

DOE/EM

Clyde Frank

DOE/PML

Phil Krey

Department of Energy Operations Offices

Albuquerque Operations

Bruce Twining

Idaho Operations

John Wilczynski

Nevada Operations

Terry Vaeth

Oakland Operations

James Turner

Oak Ridge Operations

Robert Spence
Joe LaGrone

Richland Operations

John Wageunem

Office of Scientific and Technical Information

Axel Ringe
Technical Library

DOE Remote Sensing Laboratory

Robert Kelly

Arms Control and Disarmament Agency

Thomas Graham
Janey Hatcher
John Holum

Arthur Kuehne
Stephen Ledogar
O.J. Sheaks
Steven Steiner

Bureau of Multilateral Affairs

Richard D'Andrea
David Clinard
Pierce Corden
Katherine Crittenberger
Donald Mahley
Bob Mikulak

Bureau of Nonproliferation Policy

Michael Rosenthal
Larry Scheinman
Joseph P. Smaldone

Bureau of Strategic and Eurasian Affairs

R. Lucas Fischer
Rodney Jones
Karin Look
Stanley Riveles
Davis Wollan

Bureau of Intelligence, Verification, and Information Management

Robert Cockerham
Richard Morrow
Linda Tanzini
Jerry A. Taylor
Thomas Yehl

Arms Control Intelligence Council

Craig Chellis
Craig Falci
James Meditz

Central Intelligence Agency

Pat Curtis
John Fish
Torrey Froescher
Robert Herd
Douglas J. MacEachin (2 copies)
John McLaughlin
Carter Morris
Don Pittman
Larry Turnbull
Ruth Worthen

Community Management Staff

Keith Hall
Bill Richardson
Patricia Wartell

Non-Proliferation Center

Gordon C. Oehler

Department of Defense

OUSD/Office of the Asst. to the Sec'y (Atomic Energy)

Harold Smith (3 copies)

OUSD/International Security Policy

Ashton Carter
William Kahn
Franklin Miller
Mitch Wallerstein

OUSD/Acquisition

Arthur Johnson
Frank Kendall
George Schneider
William Shuler
Thomas Troyano

OUSD/Research and Engineering

Hon. Anita Jones

OUSD/Environmental Security

Brad Smith

Defense Intelligence Agency

John Berbrich
Joe Kerr

Joint Chiefs of Staff

David W. McIlvoy

National Security Agency

Richard W. Gronet
John McConnell
John Pinkston
Michael Smith

Defense Nuclear Agency

Alane Andreozzi-Beckman
Michael Evenson
Don Linger
Cathy Monte
Roy H. Nelson
George Ulrich

Defense Technical Information Center

Kurt Molholm

Advanced Research Projects Agency

Raymond S. Colladay
Terese Esterheld

On-Site Inspection Agency

Gregory Govan
Gene McKenzie
Jeorg Menzel

Institute for Defense Analysis

Jeff Grotte

Strategic Defense Initiative Organization

Henry Cooper

U.S. Army Foreign Science and Technology Center

Keyword Cheves

U.S. Army Dugway Proving Grounds

Reed Carlson

U.S. Army, ERDEC

Joe Baranoski
Steve Godshaw

U.S. Army, SSDC (CSSD-TA)

Matthew Nichols

Defense Technology Security Administration

Edward B. Levy

Department of State

Robert Galluci
James Goodby
James P. Timbie

Bureau of European and Canadian Affairs

Alex Burkart
Alexander R. Vershbow

Bureau of Intelligence and Research

L. Elizabeth Frisa
Randolph Bell
Charles J. Jefferson

Bureau of Politico-Military Affairs

Richard Davis
Anne Harrington
Elizabeth Verville

National Security Council

Steve Andreasen
Bob Bell
Michael Fry
Elisa Harris
Daniel Poneman
Heather Wilson
Philip Zelikow

Naval Research Laboratory

Richard Cassidy
Timothy Coffey

General Accounting Office

Michael ten Kate

Federal Bureau of Investigations

Steve Killion

Congressional Offices

Senator Bingaman Staff

Ed McGaffigan

Senator Domenici Staff

Alex Flint

Senate Armed Services Committee

Gregory D'Alessio

Donald Deline

Jack Mansfield

Monica Chavez

House National Security Committee

Andrew Ellis

Senate Select Committee on Intelligence

Don Mitchell

House Permanent Select Committee on Intelligence

Diane Roark

Mark Lowenthal

Senate Foreign Relations Committee

Bill Ashworth

House Appropriations Committee

Jeanne Wilson

Senate Appropriations Committee

Mark Walker

Governmental Affairs Committee

Randy Rydel

National Institute of Justice

David G. Boyd

Los Alamos National Laboratory

Siegfried Hecker, Director

Donald Cobb (51 copies)

Lawrence Livermore National Laboratory

C. Bruce Tarter, Director

Wayne Shotts (44 copies)

NAI/Operations Div. (20 copies)

TID Library (10 copies)

Sandia National Laboratories

Ronald Andreas (23 copies)

Carolyn Hart (23 copies)

James Kelsey (23 copies)

Argonne National Laboratory

Armando Travelli (3 copies)

Brookhaven National Laboratory

Joseph Indusi (6 copies)

Idaho National Engineering Laboratory

William Blume (12 copies)

Oak Ridge National Laboratory

Robert Upchurch (4 copies)

Pacific Northwest National Laboratory

Thomas Fox (10 copies)

Savannah River Technology Center

Al Boni (3 copies)

Air Force Technical Applications Center

Charles McBrearty (5 copies)

Frank Pilotte

Univ. of Calif. National Security Panel

John F. Ahearne

Sidney D. Drell, Chair

Robert C. Dynes

JoAnn Elferink

William R. Frazer

Andrew J. Goodpaster

Raymond Orbach

Robert Peurifoy

Thomas Reed

Robert H. Wertheim

Herbert F. York

Elaine Stammon, Coordinator



