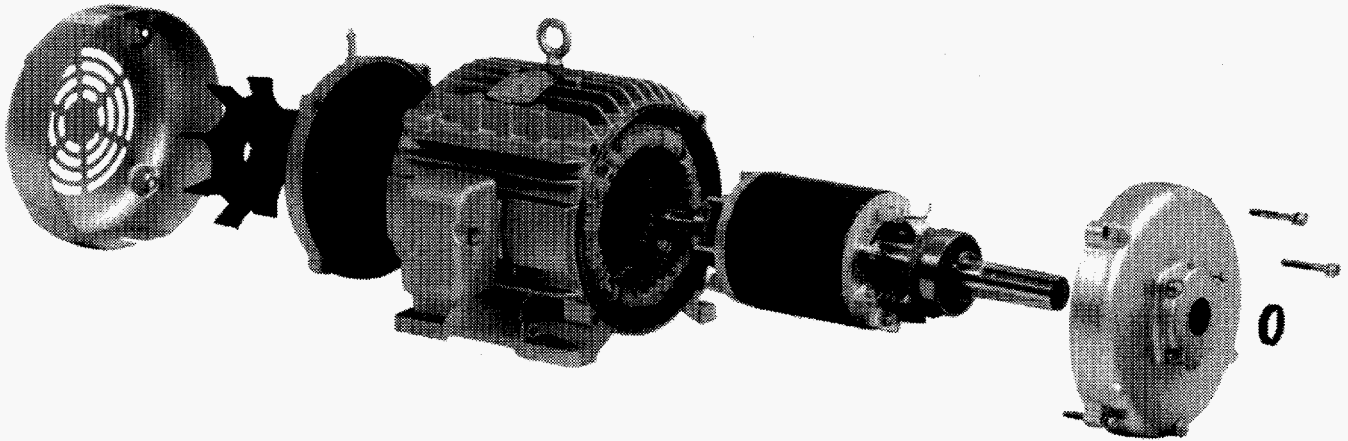


AUGUST 1995

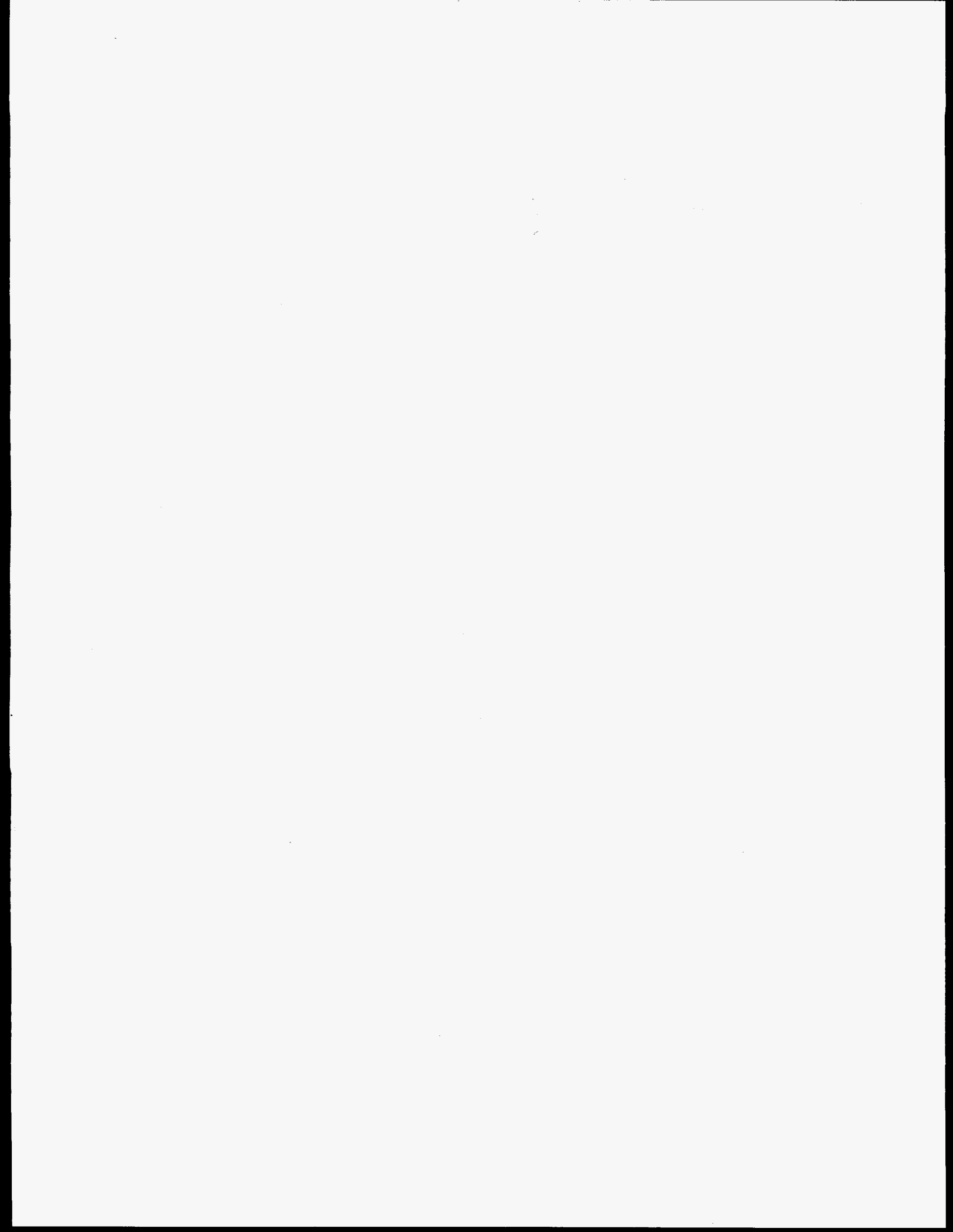
# INDUSTRIAL MOTOR REPAIR IN THE UNITED STATES



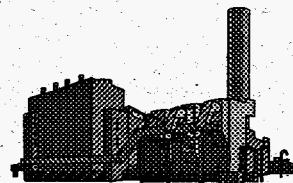
DISTRIBUTION OF THIS DOCUMENT IS UNLIMITED

**MASTER**





# BPA Report Summary



## Industrial Technology

---

### TITLE

INDUSTRIAL MOTOR REPAIR IN THE UNITED STATES

---

### SUMMARY

Maintaining energy efficiency during motor repair is tightly linked to motor performance and reliability after repair. Improving the quality of repair can help critical industrial and commercial customers manage their energy use and improve productivity. Working with the motor repair industry, utilities can provide important information and services to these customers.

---

### BPA PERSPECTIVE

This R&D project is one of a number of activities which support BPA's Market Transformation efforts. Market Transformation is a strategic effort initiated by BPA to induce lasting structural or behavioral changes in the market that result in the adoption and penetration of energy efficient technologies and practices

---

### BACKGROUND

More motor horsepower is repaired than sold each year. Improperly repairing and rewinding motors can decrease the efficiency of individual motors by up to 5 percent. Estimates of the average reduction in efficiency after repair associated with current practice range from 0.5 to 2.5 percentage points. However, efficiency decreases are not unavoidable or unexplainable consequences of repair or rewinding. Case studies of rewind motors have shown decreased efficiency to be linked to specific shortcuts, errors, or parts substitutions.

A 1 percent decrease may appear inconsequential, but when the number of repairs and motor operating hours are taken into account, the potential energy and dollar savings are significant. If all repaired motors currently in operation had been repaired with no decrease in efficiency savings would be about 2,000 aMW, roughly equivalent to the output of two large thermal power plants. Maintaining energy efficiency during repair usually improves motor performance and reliability after repair, significantly contributing to the productivity and competitiveness of motor repair

customers. By working with the motor repair industry utilities can provide information and services critical to helping industrial and commercial customers manage their energy use and improve productivity. Providing these types of services and education will be come more essential as the utility industry faces increasing competition for customers.

---

## **OBJECTIVE**

The purposes of this report are to:

- Characterize the motor repair industry in the United States;
- Summarize current motor repair and testing practice; and
- Identify barriers to energy motor repair practice and recommend strategies for overcoming those barriers.

This objective is part of a broader goal to achieve a more energy efficient population of motors through appropriate selection of high efficiency new motors and improvements in repairs.

---

## **PROJECT MANAGER**

Craig Wohlgemuth, P.E.  
Technical Assessment/R&D-MPMT  
Bonneville Power Administration  
P.O. Box 3621  
Portland, OR 97208  
(503) 230-3044

---

## **ORDERING INFORMATION**

Report Number: DOE/BP-2749

**For copies of Publications on this list please contact:**  
**Public Information Office**  
**Bonneville Power Administration**  
**P.O. Box 3621**  
**Portland, OR 97208**  
**(503) 230-3478 (Portland)**  
**or**  
**1-800-622-4520 (Document Request Line)**

# Industrial Motor Repair in the United States:

Current Practice and Opportunities  
for Improving Customer  
Productivity and Energy Efficiency

Prepared for: Electric Power Research Institute  
Bonneville Power Administration and  
United States Department of Energy

Prepared by: Vince Schueler, Paul Leistner and  
Johnny Douglass

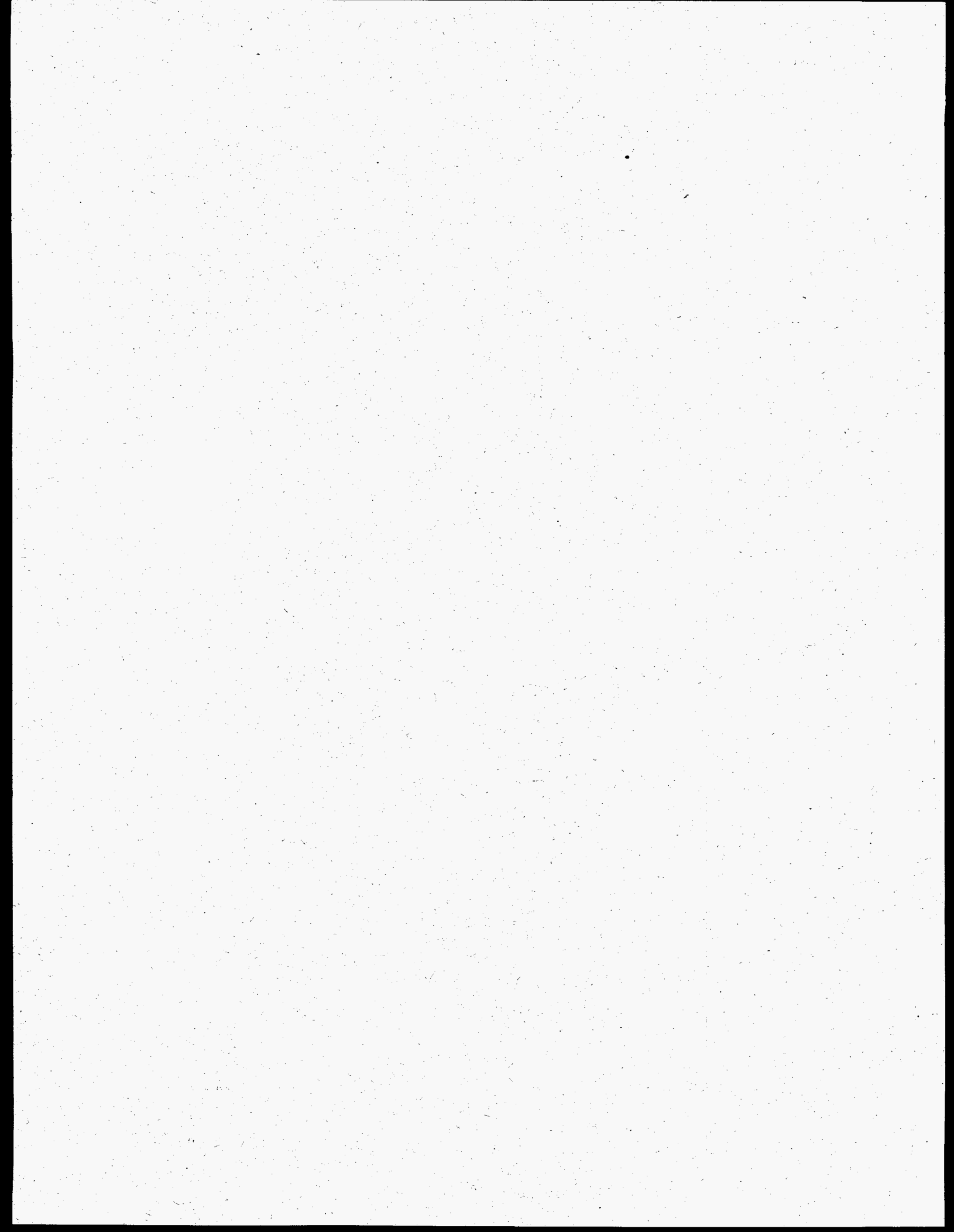
Washington State Energy Office  
925 Plum St. SE, Building 4  
P.O. Box 43165  
Olympia, WA 98504-3165



Printed on recycled paper  
September 1994  
WSEO #94-088

**WSEO**  
*Washington State Energy Office*

**DISTRIBUTION OF THIS DOCUMENT IS UNLIMITED**



## Disclaimer

This report was prepared by the Washington State Energy Office as an account of work sponsored by the Electric Power Research Institute, the Bonneville Power Administration and the United States Department of Energy. Neither the United States, the Bonneville Power Administration, the Electric Power Research Institute, the State of Washington, the Washington State Energy Office, nor any of the contractors, subcontractors or their employees, makes any warranty, expressed or implied, or assumes any legal responsibility for the accuracy, completeness, or usefulness of any information, apparatus, product, or process disclosed within the report.

## Acknowledgments

The authors wish to thank the Electric Power Research Institute (EPRI), the Bonneville Power Administration (BPA) and the United States Department of Energy (USDOE) for funding this project. Particular thanks are due to Ben Banerjee at EPRI, Craig Wohlgemuth at BPA, and Paul Scheihing and Rich Been at USDOE for their support and direction.

We would also like to extend our appreciation to the Electrical Apparatus Service Association, including Wallace Brithinee, Tom Bishop, Dick Nailen, Steve Darby, and many other shop owners who cooperated closely with us to help provide a sample, review surveys and reports and help us understand the practical realities of the motor repair shop floor. Additional valuable review, comments and insights were provided by Dale Friesen at Manitoba Hydro, Mark Webb at Virginia Power, and Markus Zeller of Demand Side Energy Consultants.

We would also like to thank Don Lammers of Vaughen's Price Publishing Company, Inc., publisher of *Vaughen's Complete Price Guide for Motor Repairs and New Motors*, which provided data and ideas for motor repair costing issues.

This report would not have been possible without the assistance of Linda Dethman and the staff at SBW, Inc. of Bellevue, Washington, which successfully administered a very long and complex survey to the project's sample of motor repair shops. Linda Dethman also provided valuable insight on the final organization of the report.

Finally, we would like to thank all of the motor shops which took the time to participate in this survey and allowed site visits.

# Executive Summary

Electric motors consume almost half the end use electricity consumed in the United States. In 1985, more than 19 million motors over 5 hp were in operation. These motors accounted for 47 percent of the 2,326 billion kWh consumed in electric end uses in that year. In any given year, more motors over 5 hp are repaired than are sold new. In 1993, at least 2 million motors between 5 and 500 hp totaling over 200 million hp were repaired in the United States.

Motors *can* be rewound with no reduction in efficiency. If all the motors repaired in 1993 had been repaired with no loss in efficiency, electric energy use would have decreased by between 200 and 300 average megawatts (aMW).<sup>1</sup> If all repaired motors currently in operation had been repaired with no efficiency decreases, savings would be about 2,000 aMW, roughly equivalent to the output of two large thermal power plants.

Maintaining energy efficiency during motor repair is tightly linked to motor performance and reliability after repair. Improving the quality of repair can help critical industrial and commercial customers manage their energy use and improve productivity. Working with the motor repair industry, utilities can provide important information and services to these customers. Providing these types of services and education will become more essential as the utility industry faces increasing competition for customers in the future.

## Purpose of Report

This report was prepared with the support of the Electric Power Research Institute, Bonneville Power Administration, and the U.S. Department of Energy. The purposes of this report are to:

- Characterize the motor repair industry in the United States;
- Summarize current motor repair and testing practice; and
- Identify barriers to energy efficient motor repair practice and recommend strategies for overcoming those barriers.

We drew on three sources of information to complete this study:

- An extensive review of the literature;
- Key informant interviews and site visits with 10 motor repair shops; and
- A national survey of 65 motor repair shops conducted in May and June 1993.

## The Motor Repair Industry

As estimated in the survey, there are approximately 4,100 motor repair shops in the United States. These shops repaired between 1.8 and 2.9 million motors in 1993 generating an estimated \$2 billion in gross annual repair revenues. Motor repair services accounted for approximately two-thirds of total shop revenues from all sources. Almost all shops sold new or rebuilt motors in addition to their repair business.

---

<sup>1</sup>An "average megawatt" (aMW) is equal to one megawatt of capacity produced continuously over the period of one year. (1 megawatt x 8,760 hours (the hours in one 365-day year) = 8,760 megawatt-hours or 8,760,000 kilowatt hours.)



The motor repair industry is dominated numerically by small shops; however, larger shops have the biggest share of the market as they are likely to repair more and larger motors. Three quarters of the shops had ten or fewer employees. These smaller shops repaired 45 percent of the total motors and 25 percent of the total horsepower. Smaller shops were less likely than larger shops to have the capital and human resources for testing and quality control practices.

The motor repair industry is in a state of transition. Repair shops are under tremendous pressure to reduce costs, improve quality assurance and technical services, and reduce lead times. The pressures are caused by increasing labor costs, competition from low cost replacement motors, and customer demands. The most frequently mentioned challenges shops said they faced included a shift by their customers from motor repair to replacement, the eroding U.S. industrial base, the increasing costs of complying with government regulations, and increasing labor and equipment costs.

The penetration of energy efficient motors is increasing. In 1990, the Electric Power Research Institute (EPRI) estimated that about 20 percent of new motors sold that were over 5 hp could be classified as energy efficient, and that by the year 2,000 energy efficient motors could account for two-thirds of new motor sales.

As of 1993, more than 160 utilities in over 30 states offered new motor rebates or other incentive programs. To the extent that rebates reduce motor first costs, these programs encourage motor replacement over repair, particularly for smaller motors. In addition, some utility programs also require program participants to scrap the replaced motor. Small shops feel particularly hard hit since they are more likely to repair small motors and are less able to compete successfully for sales of new premium efficiency motors.

Most utilities in the United States, with the exception of Virginia/North Carolina Power, currently do not run demand-side management (DSM) programs targeted to motor repair.

### **Current Motor Repair and Testing Practice**

The median length repair shops have been in business was 25 years. The shops we surveyed had a strong craftsman ethic and a desire to do good work despite customer requirements for fast turnaround. Customers did not routinely ask for quality repair. Repair specifications from customers of any type were the exception and not the rule.

Only one-third of the shops used written quality assurance standards of any type and were familiar with quality assurance procedures. Testing practices vary widely from shop to shop. Testing was most often used as a diagnostic tool for troubleshooting. Although insulation, winding resistance, vibration, and core loss testing should be done routinely as part of a quality repair, only insulation testing was done regularly.

Nine out of ten shops use a burn-out oven to remove windings. Burn-out practices remain a problem. Burn-out equipment is often primitive, temperature controls are not often calibrated, and 40 percent of the shops reported typical burn-out temperatures over 700° F.

Forty-two percent of the shops reported problems winding motors with original size wire because of insufficient room in the slots or the unavailability of the correct wire sizes. Eighty-one percent of the shops reported that they changed winding configurations because of equipment limitations or shop preference. Several shops also reported difficulties with bearing replacements because they had difficulty obtaining specifications and special and sometimes proprietary bearings.

## **Impacts of Motor Repair on Motor Efficiency**

Comprehensive studies of the magnitude and causes of efficiency decreases after motor repair that are generalizable to the broader motor population are not available. Five empirical case studies have been done that measure efficiency loss after motor repair on a total of about 50 motors. These studies reported that:

- Efficiency decreased between .5 and 2.5 percent at full load after repair. Estimates converged on about 1 percent for motors under 100 hp and about .5 percent for larger motors.
- The efficiency of premium efficiency motors can be maintained during repair. Decreases in efficiency after repair for these motors were less than one percent.
- No single practice leads to reduced efficiency after repair. Studies done to date have identified many sources of efficiency reduction. These include, but are not limited to, high temperature burn-out of cores, improper bearing replacement, the use of smaller diameter wire, or changing winding patterns during rewinds.

## **The Link Between Maintaining Energy Efficiency And Quality Repair**

Energy efficient repair of motors may be easier to define by what it isn't than by what it is. At its most basic level, the goal of energy efficient repair of motors is to return the motor to original manufacturer specifications in a manner that does not decrease efficiency. Maintaining energy efficiency during repair is a process consisting of many small steps. There are two major elements of this process:

- Avoiding practices which degrade efficiency; and
- Appropriate testing before and after repair to diagnose potential sources of decreased efficiency.

It is not surprising that the Canadian utilities, which are on the leading edge of efforts to reduce efficiency decreases during repair, have found a strong link between shop quality assurance efforts and the likelihood motors will be repaired without decreasing efficiency. To emphasize this critical link, Canadian utilities refer to their programs as "quality" motor repair and their goal as quality motor repair. By encouraging and supporting quality assurance and quality repair, efficiency losses can be reduced and the reliability of rewound and repaired motors improved in a manner that delivers energy savings and supports a strong motor repair industry.

For many motor repair customers and utilities the improved reliability and related productivity gains associated with quality repair are more compelling than the energy benefits. Excepting the larger motor users, energy management and cost savings considerations alone will not be significant enough to motivate action. Utilities in the United States are looking beyond providing demand side management services and reducing energy use. To retain important customers, they are moving towards providing broader services to help their customers manage their energy use and improve productivity. Working with repair shops and customers to insure quality motor repair can be an important opportunity.

## **Barriers to Quality Motor Repair and Rewind**

Educational, financial, infrastructure, and technical barriers need to be addressed to insure broad implementation of quality motor repair practices that maintain energy efficiency.

## Education Barriers

Motor Repair Customers Do Not Recognize Quality Motor Repair and Seldom Ask For It. The shops we surveyed reported that their customers seldom provided any repair specifications, much less specifications for quality repair or for maintaining energy efficiency. Customers need tools to identify:

- The elements of a quality repair.
- The challenges faced by repair shops and what shops need from the customer to provide the best repair.
- The value of paying for higher levels of service (and efficiency).
- How to get higher levels of service (and motors rewound without efficiency reduction) from shops.

## Recommendations

- Establish a voluntary, industry-led repair shop certification program requiring training, key testing equipment, and implementing existing quality assurance standards (e.g., EASA -Q). Provide an easy to recognize certification label, such as "Energy Star Motor Repair Shop."
- Educate motor users on identifying quality repair shops and the benefits of higher levels of service. Utilities have an important role here.

Many Repair Shops Do Not Understand How to Maintain Energy Efficiency During Repair. Many shops do not understand how to maintain energy efficiency during motor repair or appreciate that it is important to do so. Among misperceptions we encountered were:

- Energy efficient repair practice is only important in repairing premium efficiency motors.
- Premium efficiency motors are significantly more costly and more technically difficult to repair than standard efficiency motors.
- Core losses from burn-out practices are the only important source of decreased efficiency, and controlling burn-out is the only important loss prevention strategy.

We also found a significant number of repair shops, especially smaller ones, were not aware of key quality repair practices.

- Eighty percent of the shops surveyed reported they changed winding configurations. Many shops did not appear to be aware of the potential consequences of changing winding patterns without adequate redesign.
- Forty-one percent reported typical burn-out temperatures in excess of 750 °F.
- Proper testing, which may include tests for insulation integrity, winding resistance, vibration, rotor balance, and core loss is essential for all repairs. It appears that only insulation testing is done routinely.

## Recommendations:

- Continue to provide solid technical data to shops through industry associations and utilities.
- Complete practical guidebooks on maintaining energy efficiency through quality repair.
- Provide training seminars on maintaining energy efficiency during motor repair in conjunction with key repair industry conferences.

- Improve the visibility of efficiency in shops (e.g., "Do's and Don'ts" posters).
- Link energy efficiency more effectively to motor reliability.
- Include standards for burn-out equipment and calibration intervals in voluntary certification programs.

### **Financial Barriers**

Quality Repair Costs More. Quality motor repair practices can be expected to increase repair costs by up to 10 percent. Sources of increased costs include additional equipment and labor for testing, controlling burn-out and maintaining adequate stocks of parts and wire.

#### Recommendations

- Support programs linking energy efficiency issues to quality assurance. Utilities and federal agencies can encourage quality assurance through awards for outstanding quality assurance efforts and support for training and certification programs.
- Provide rebates to repair shops for expensive testing equipment (particularly core loss testers).
- Provide financial incentives to encourage purchase of burn-out ovens with better controls.

Working With Small Shops In An Industry In Transition. Any effort to work with the motor repair industry must acknowledge that the industry is under pressure from declining profit margins, increasing labor costs, and the declining manufacturing base in the economy. Shops will resist efforts that rely on more government regulation and mandates. Additional mandates could weaken the industry.

Numerically, the industry is dominated by small shops that have low repair volumes, work on smaller hp motors, and have small staffs. These shops are the least likely to have the right equipment or training for quality repair and are the least able to afford it. Requirements for more equipment and testing and for maintaining larger stocks of spare parts could have the indirect impact of driving smaller shops out of the repair business. Large investments to improve equipment and operating practices in small shops may not be justified because of small business volumes.

#### Recommendations

- Identify low cost strategies, such as tips sheets, to improve practice in small shops. Develop both best practice testing manuals and alternative lower cost approaches for smaller shops to use. For example, procedures in EASA Tech Note 17 can be used in lieu of purchasing a commercial core loss tester.

### **Infrastructure Barriers**

Manufacturer's Motor Specifications are Often Unavailable Or Not Accessible. Shops reported that winding data was not readily available for 30 to 40 percent of the motors they repaired. Specifications for bearings, fans, and lubricants are not accessible in a timely fashion from all manufacturers.

### Recommendations

- Publicly recognize motor manufacturers that provide good access to manufacturing specifications for repair shops.
- Develop a 1-800 or same-day service for manufacturer's data.
- Work with motor manufacturers to develop a computer database for motor winding data (RewindMaster). This database should also include core loss, grease, bearing, and fan specifications.
- Encourage all motor manufacturers to release motor specifications and cooperate more effectively with the repair industry. The federal government and utilities have a role here.

Some Parts and Wire Sizes Are Not Available Locally. Small and mid-size shops reported difficulties keeping complete stocks of wire sizes and bearing types on hand. Shops will use substitutes if the correct sizes or types are not available.

### Recommendations

- Encourage motor manufacturers to stock replacements for custom bearings and to make them available quickly and without excessive markup.
- Develop a recommended wire and parts stocking list for the "well-equipped shop."
- Work with manufacturers and industry associations to develop a specialty wire and parts clearinghouse to locate and ship hard-to-find parts, if such a service is not already available.
- Encourage smaller shops to form local purchasing cooperatives for hard-to-find parts and wire.

Tools and Equipment For Winding and Winding Redesign Are Not Available. Even with good winding data and the right wire in stock, shops change winding patterns without proper redesign because they do not have the right winding equipment or the analytical tools for redesign.

### Recommendations

- Place greater emphasis on the importance of maintaining wire size and winding configuration in education efforts and technical notes.
- Include minimum winding equipment standards in certification program and quality assurance standards.

### **Technical Barriers**

Winding Removal Strategies That Do Not Damage Motor Cores Are Needed. Most windings are removed by burning them out in ovens. Almost 40 percent of the shops surveyed burned out cores at temperatures of 750° F or more, which can cause core damage. Forty percent of the shops in the survey did not have water suppression systems, most temperature controls were not frequently calibrated, and few shops placed temperature sensors in the motor cores.

### Recommendations

- Develop dips and varnishes that are easier to strip or burn-out during rewind. Chemical companies need to work with motor repair shops and manufacturers to develop more effective processes and products. Federal research support could accelerate progress.
- Support research on low-cost strategies for improving temperature control and distribution during burn-out. Field research on the effects of over and under heating in uncalibrated ovens may be instructive.

Lack of Standardized Designs. One of the biggest barriers to returning motors to original condition shops reported was finding parts and wire for motors using non-standard components. The diversity of wire size, bearing types, and other motor components that a motor repair shop must work with is very challenging.

#### Recommendations

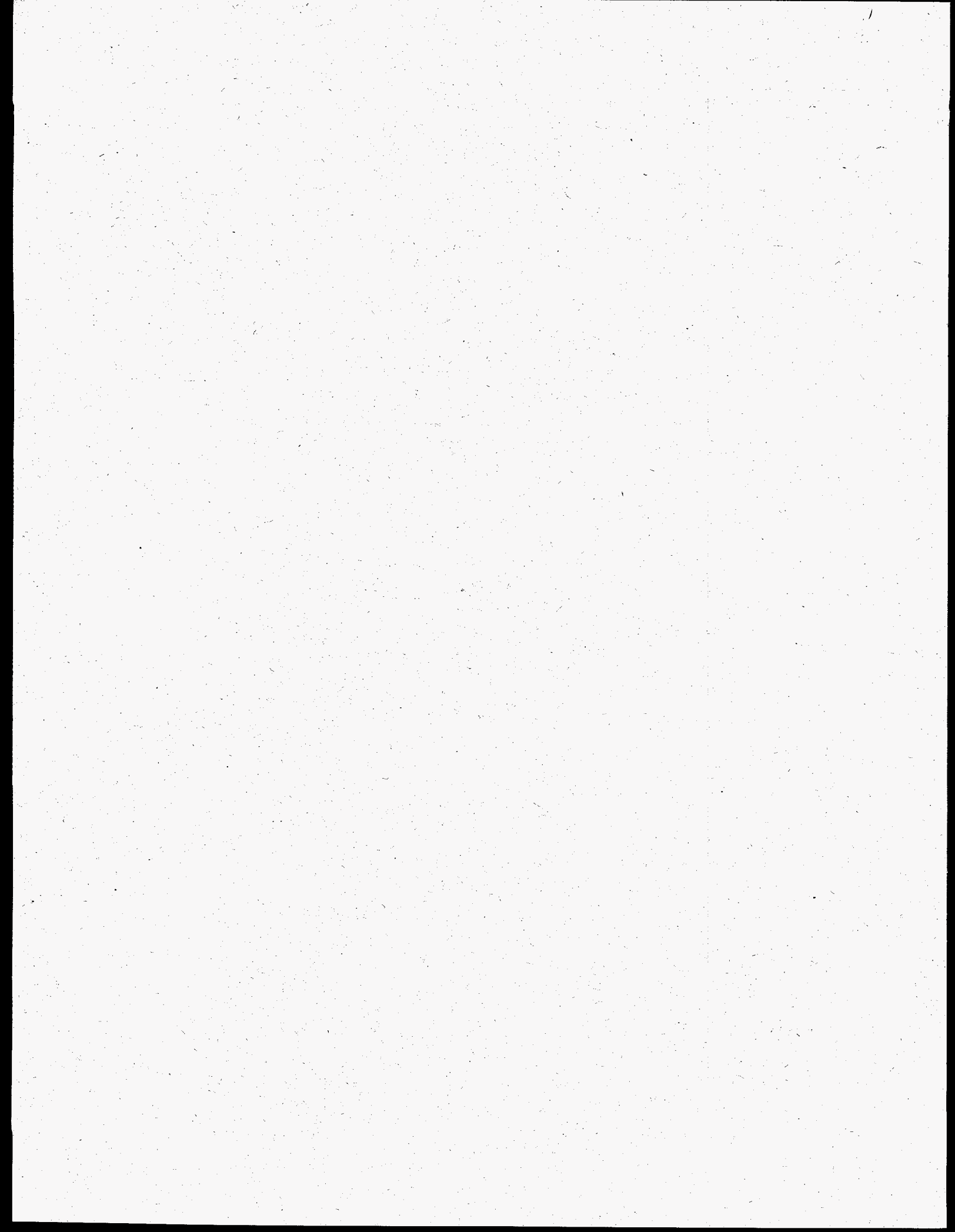
- Explore working with manufacturers to standardize key motor part as is now being done in the European motor market.

Comprehensive data on the magnitude and sources of increased losses after motor repair and the costs and effectiveness of remedies is needed. Little comprehensive research has been done to associate the magnitude of efficiency decreases with specific motor repair practices and to understand how these practices interact. Existing studies have very small sample sizes and are restricted to small hp motors. Key questions that need further investigation include:

- Are the efficiency decreases for large motors of the same magnitude as for smaller motors? Are problem practices as common in the repair of larger motors?
- What are the efficiency and performance implications of specific problem repair practices? Priority areas of investigation are bearing change outs, changing winding configurations (especially concentric to lap), altering wire sizes, and core loss damage.
- How effective are alternative strategies for reducing core loss during burnout (oven calibration, water suppression systems, and alternative burn-out regimes) and for diagnosing core losses?
- How much do specific repair practices that maintain efficiency contribute to motor reliability and performance? For example, does using smaller wire size significantly impact repair life?
- What are the incremental costs for specific repair practices that maintain efficiency?

#### Recommendations:

- Establish a bench testing program where motors over a wide range of hp are tested with a variety of alternate wire sizes and configurations and repair problems.
- Work cooperatively with a sample of repair shops to demonstrate quality repair practices and track any related incremental costs (referenced to current industry practices).
- Assess the effectiveness of alternative strategies for limiting core damage during burn-out and continue investigation of oven performance issues.
- Initiate a long-term study comparing failure rates of motors repaired in shops whose staff have been trained in quality repair techniques with a control group of shops with untrained staff.
- Coordinate efforts with the Canadian Utility Consortium, which is a leader in this area.



# Contents

<b>Chapter 1</b>	<b>Introduction</b>	<b>1</b>
	Why are repairs and rewinds important?	1
	Purpose and Objectives/Links to other Products	2
	Definitions and Background	2
	Motors	2
	Motor Repair	2
	Defining Energy Efficiency	2
	What is an Energy Efficient Repair?	3
	Shop Size	3
	Methods	4
<b>Chapter 2</b>	<b>The Motor Repair Market</b>	<b>5</b>
	Market Size	5
	Service Structure	6
	What the Customer Wants	9
	Recent Developments	10
	Motor Repair Industry Trends	10
	Premium Efficiency Motors	12
	Market Penetration	12
	Utility Rebate Programs	12
<b>Chapter 3</b>	<b>Energy Savings Potential</b>	<b>15</b>
	Sources of Decreased Efficiency During	
	Motor Repair	15
	What is the Savings Potential?	18
	Energy Impacts of Current Motor Repair	
	and Rewind Practices	18
	The Motor Repair Population	19
<b>Chapter 4</b>	<b>Motor Repair Practice</b>	<b>21</b>
	Motor Repair and Quality Assurance	
	Specifications	21
	Specifications from the Customer	21
	Written Repair and Quality Assurance	
	Standards	22
	Motor Testing	23
	Testing Equipment	24
	Testing Practices	26
	No Load Power Testing	27
	Vibration Testing	27
	Load Testing	29
	Insulation Testing	29
	Winding Resistance Testing	30
	Core Loss Testing	32



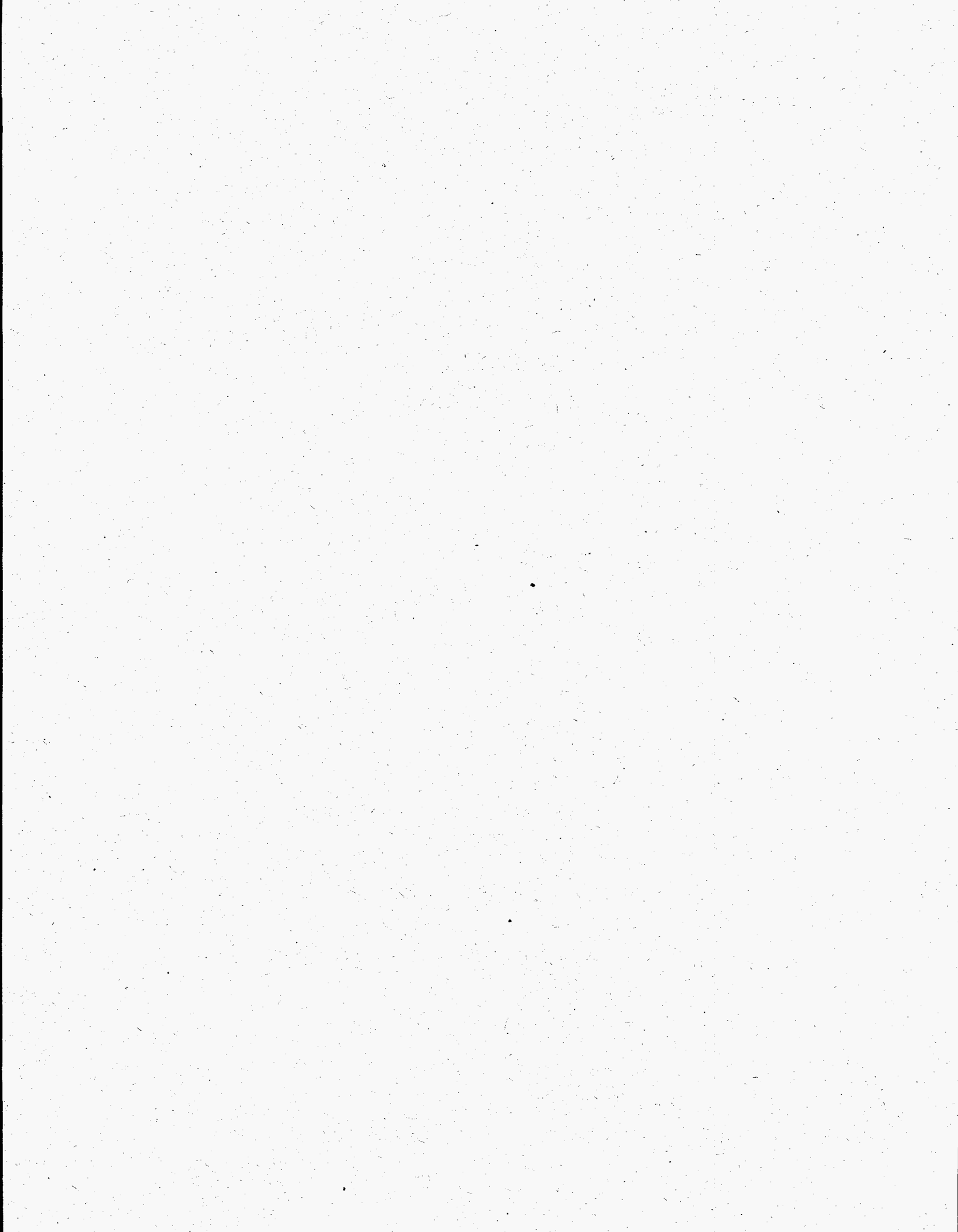
	Winding Removal	33
	Chemical Stripping	33
	Burn-out Ovens	34
	Winding Practice	35
	Bearings	39
	Repair of Energy Efficient Motors	40
<b>Chapter 5</b>	<b>Motor Repair/Rewind Costs</b>	43
	Overall Improvements in Motor Repair Practice	43
	Repairing Premium Efficiency Motors	43
	Energy Cost Savings Potential For Individual Motors	45
<b>Chapter 6</b>	<b>Recent Utility and Government Initiatives in Energy Efficient Repair</b>	47
	Utility Programs	47
	Canadian Utilities	47
	United States Utilities	48
	U.S. Government Initiatives	49
<b>Chapter 7</b>	<b>Barriers to Energy Efficient Rewinds</b>	51
	Many Shops do not Understand How to Maintain Energy Efficiency Practice	51
	Most Motor Repair Customers Do Not Recognize Quality Motor Repair and Seldom Ask for It	53
	Manufacturer's Data on Original Motor Specifications is Often Unavailable or Not Accessible	53
	Some Parts and Wire Sizes are Not Available Locally	54
	Some Shops Lack the Tools and Equipment for Winding and Winding Redesign	55
	Removing Windings in a Manner Which Does Not Damage Motor Cores	55
	Insufficient Testing During Motor Repair	56
	Working with Small Shops in an Industry in Transition	57
	Lack of Data on Efficiency Decreases After Repair and the Costs and Effectiveness of Remedies	57
	Technical Problems Associated with Tighter Tolerances and Slot Fills	58
	<b>References</b>	61
	<b>Appendix A</b>	
	Motors and Motor Efficiency	A-1

**Appendix B**  
Survey Methodology and Motor Repair Shop  
Questionnaire

B-1

**Appendix C**  
Motor Efficiency Losses: Types, Causes,  
Diagnosis, and Remedies

C-1



# List of Figures

<b>Figure 1</b>	Share of Motor Repair Market by Size of Shop	5
<b>Figure 2</b>	Motor Repair Shop Services	6
<b>Figure 3</b>	Mean Percent of Motors Repaired by hp Range	7
<b>Figure 4</b>	Major Industries Served by Shops in Sample	8
<b>Figure 5</b>	Rewind and Rewind/Repair Cost as a Percentage of New Motor Cost	11
<b>Figure 6</b>	State With Utilities Offering Rebates For High Efficiency Motor	13
<b>Figure 7</b>	Technical Savings Potential for Motors Repaired in 1993	18
<b>Figure 8</b>	How Often Do Customers Provide Repair Specifications	21
<b>Figure 9</b>	Types of Customer Specifications Reported	22
<b>Figure 10</b>	Shops Having Quality Assurance Standards	23
<b>Figure 11</b>	Percent of Shops Having Test Equipment	25
<b>Figure 12</b>	Range of Voltage Shops are Capable of Providing With/Without a Controller	26
<b>Figure 13</b>	Frequency of No-Load Power Testing	27
<b>Figure 14</b>	Frequency of No-Load Vibration Testing	28
<b>Figure 15</b>	How Many Jobs Do You Check the Dynamic Balance of Motor Rotors?	28
<b>Figure 16</b>	Frequency of Load or Performance Testing	29
<b>Figure 17</b>	Frequency of Insulation Testing	29
<b>Figure 18</b>	Frequency of Insulation Testing And The Use of Insulation Test Equipment	30
<b>Figure 19</b>	Frequency of Winding Resistance Testing	31
<b>Figure 20</b>	Does Shop Measure Winding Resistance During Repair	31
<b>Figure 21</b>	Does Shop Have Core Loss or Loop Test Capability?	32
<b>Figure 22</b>	Frequency of Core Loss or Loop Ring Testing	32
<b>Figure 23</b>	Method used for Removing Windings	33
<b>Figure 24</b>	Frequency of Burn-Out Oven Temperature Control Calibration	34
<b>Figure 25</b>	Typical Temperature Settings reported for Burn-Out Ovens	35
<b>Figure 26</b>	Shops Reporting Problems Winding With Original Wire Size	36
<b>Figure 27</b>	Why is More Copper Added During Winding	37
<b>Figure 28</b>	What Do You Do When Winding Data is Not Available	38
<b>Figure 29</b>	Reasons Shops Change Winding Patterns	39
<b>Figure 30</b>	Do You Charge More for Premium Efficiency Motor Repairs?	43
<b>Figure 31</b>	Annual Savings for a 25 hp And a 150 hp Motor	45
<b>Figure 32</b>	Annual Energy Savings of 1 Percent Avoided Efficiency Decrease by Horsepower	46
<b>Appendix A</b>		
Key Motor Parts		A-1

**Appendix B**  
Regions and States Used For Drawing EASA and  
Non-EASA Samples

B-1

## List of Tables

<b>Table 1</b>	Percent of Shops Reporting Work Contracted Out	7
<b>Table 2</b>	Median Number Years in Business	7
<b>Table 3</b>	Motor Repair Shop Ratings of Reason Their Customers Choose Repair Shops	10
<b>Table 4</b>	Major Challenges Faced by the Motor Repair Industry	11
<b>Table 5</b>	Empirical Studies of Efficiency Loss During Motor Repair	16
<b>Table 6</b>	Major Sources of Decreased Efficiency During Motor Repair/Rewind	17
<b>Table 7</b>	Effect of Changes in Segregated Losses on Total Losses for Ten Repaired Motors	17
<b>Table 8</b>	Key Assumptions Used in Calculating kWh Impacts by Motor hp	19
<b>Table 9</b>	Important Test For Diagnosing Major Sources of Increased Losses	24
<b>Table 10</b>	Frequency Categories Used to Summarize Testing Data	26
<b>Table 11</b>	When is Core Loss Testing Typically Done?	33
<b>Table 12</b>	Reasons Manufacturer's Winding Data is Not Available	38
<b>Appendix A</b>		
	Average Electric Motor Life	A-1
	Motor Failure Survey Results from Large Motor Repair Shop	A-2
	Contribution of Motor Losses to Total Motor Loss	A-3
<b>Appendix B</b>		
	Sample Disposition	B-2

# Chapter 1

## Introduction

### Why are repairs and rewinds important?

Electric motors use almost half the end use electricity consumed in the United States. In 1985, more than 19 million motors over 5 hp were in operation in the United States. Motors over 5 hp accounted for 47.5 percent of the 2326 billion kWh consumed in electric end uses in that year (EPRI 1992). According to a study done in New England in 1992, 33 percent of all failed motors are rewound and repaired, and an additional 9 percent are replaced with used motors (Fryer and Stone 1993). The proportion of failed motors that are repaired approaches 90 percent for motors over 50 hp.

Between 1.8 and 2.9 million motors between 5 and 500 hp, totaling over 200 million hp, were repaired in the United States in 1993. Improper repair and rewind of motors can degrade motor efficiency by up to 5 percent for individual motors. Estimates of the average reduction in efficiency after repair range from 0.5 to 2.5 percentage points (McGovern 1984, Zeller 1992, Ontario Hydro 1992). Most of the estimates converge on an average decrease in efficiency of about 1 percent.

In absolute terms this decrease may appear inconsequential, but when the number of repairs and motor operating hours are taken into account, the potential energy and dollar savings are significant. If all the motors under 500 hp repaired in 1993 had been repaired with no efficiency losses, electric energy use would have decreased by between 200 and 300 average megawatts (aMW) a year. If all repaired motors currently in operation had been repaired with no decrease in efficiency, savings would be about 2000 aMW, roughly equivalent to the output of two large thermal power plants.<sup>1</sup>

Maintaining energy efficiency during repair is tightly linked to motor performance and reliability after repair. Improving the quality of motor repair can significantly contribute to the productivity and competitiveness of motor repair customers. Working with the motor repair industry, utilities can provide important information and services to critical industrial and commercial customers to help them manage their energy use and improve productivity. Providing these types of services and education will become more essential as the utility industry faces increasing competition for customers.

---

<sup>1</sup> An "average megawatt" (aMW) is equal to one megawatt of capacity produced continuously over the period of one year. (1 megawatt x 8,760 hours (the hours in one 365-day year) = 8,760 megawatt-hours or 8,760,000 kilowatt hours.)

# Purpose and Objectives

This report was prepared with the support of the Electric Power Research Institute, Bonneville Power Administration, and the U.S. Department of Energy. The purposes of this report are to:

- Characterize the motor repair industry in the United States;
- Summarize current motor repair and testing practice; and
- Identify barriers to repairing motors in manner that maintains efficiency and recommend strategies for overcoming those barriers.

This report is a companion piece to the *Energy Efficient Motor Repair Guidebook* also being prepared at the Washington State Energy Office (WSEO). The Guidebook provides detailed technical information on energy efficiency and motor repair.

## Definitions and Background

### Motors

Electric motors are machines that convert electrical energy into rotational (mechanical) energy by means of electromagnetism. Motors can use either alternating current (AC) or direct current (DC). Most non-fractional horsepower (hp) motors in use are three phase AC induction motors. Our focus in this report is three-phase AC induction motors between 5 and 500 hp. For an introduction to motor basics, motor lifetimes, and major sources of efficiency loss see Appendix A.

### Motor Repair

Throughout this report we use the terms motor repair and motor rewind. The terms are not interchangeable. Rewinding has become synonymous with repair because many of the most serious motor failures require replacement of the wire coils (stator windings) that produce the magnetic field. Since other mechanical repairs are done during a rewind, we only use the term "rewind" in cases in which motor windings are replaced. Motors are also sent to shops for preventative maintenance on a scheduled basis. This type of servicing, which includes cleaning, inspection and rebalancing but generally not repair or rewind, may involve up to 10 percent of repair shop business. Because they do much more than rewinding, shop owners prefer calling their business motor repair or motor service rather than motor rewind. We follow this convention and use rewind as a subset of motor repair. We exclude service and inspection work from our definition of motor repair, but we are not certain that the shops we surveyed made that distinction.

### Defining Energy Efficiency

There is much confusion in the motor industry surrounding the use of the term "energy efficient." Almost three quarters of those we surveyed had a difficult time explaining energy efficiency. This is not surprising. Standards for determining the level of energy efficiency in new motors are complex and depend on characteristics specific to a motor. Energy efficiency is also linked to broader issues of motor operation, loading, and repair practices. Further, determining rated efficiency for motors requires following complex testing protocols using sophisticated equipment that many shops do not have.

An energy efficient motor is a motor exceeding a specified nominal full load efficiency level under test conditions. The National Electrical Manufacturers Association (NEMA) has developed standard definitions and test procedures to establish efficiency criteria for motors. Table 12-9 (Formerly 12-6B) of NEMA MG-1 provides the minimum NEMA standard for energy efficiency. Some in the motor industry label these motors as "energy efficient." Motors that meet NEMA Table 12-10 (formerly designated NEMA 12-6C), NEMA's more stringent "suggested standard for future design," are referred to as "premium efficiency" motors in the industry. The 12-10 efficiency levels will be the lowest efficiency levels allowed for standard motor applications when the National Motor Standards established in the 1992 Energy Policy Act go into effect in 1997. To avoid confusion with other uses of the term, we use the phrase "premium efficiency" to mean motors meeting the 12-10 standard.

## **What is an Energy Efficient Repair of a Motor?**

Energy efficient repair of motors may be easier to define by what it isn't than by what it is. Most repaired and/or rewound motors can be restored to original rated efficiency levels. In a very limited number of situations efficiency can actually be increased for some motors by adding more copper. At its most basic level, the goal of energy efficient motor repair is to return the motor to original manufacturer specifications in a manner that does not decrease efficiency.

Maintaining energy efficiency during repair is a process consisting of many small steps. There are two major elements of this process:

- Avoiding practices that degrade efficiency; and
- Appropriate testing before and after repair to diagnose potential increases in loss.

Based on research and experience, Canadian utilities are finding that shops that have a strong quality assurance program and use it are far more likely to maintain energy efficiency during rewinds. They are also more likely to deliver repaired motors that are reliable and repaired in a way that meets customer needs (Friesen 1994). Since the phrase "energy efficient motor repair" implies that only energy efficient motors are affected, the Canadian utilities prefer the term "quality repair." Their use of this term reinforces the link between quality assurance and maintaining efficiency levels. We use "quality repair" and "energy efficient repair" of motors interchangeably.

## **Shop Size**

We have placed shops in small, medium, and large size categories. For estimates of market size and revenues, we had to use the definitions provided by the telephone Yellow Pages listing service we used to develop the sample. These categories were: small - under 10 employees; medium - 10 to 49 employees; and large - 50 or more employees.

These categories should be interpreted with care. The employee data provided by shops to the Yellow Pages service and to EASA did not always reflect the number of staff devoted solely to motor repair. Most shops sell new motors or repair electrical equipment other than motors. For the remainder of the report we defined shop size by the number of employees who worked on or supported motor repairs as reported by each shop in the survey. The categories are: small (1-3 employees), medium (4-14), and large (15 or more).



# Methods

We drew on three sources of information to complete this study:

- An extensive review of the literature;
- Key informant interviews and site visits with 10 motor repair shops; and
- A national survey of 65 motor repair shops conducted in May and June 1993.

The motor repair shops included in the survey were randomly selected within three sample strata. The three sample strata: membership in the Electrical Apparatus Service Association (EASA), number of employees, and geographic region, were developed to ensure the sample was reasonably representative. See Appendix B for a copy of the survey instrument and a discussion of sampling procedures.

## Chapter 2

# The Motor Repair Market

## Market Size

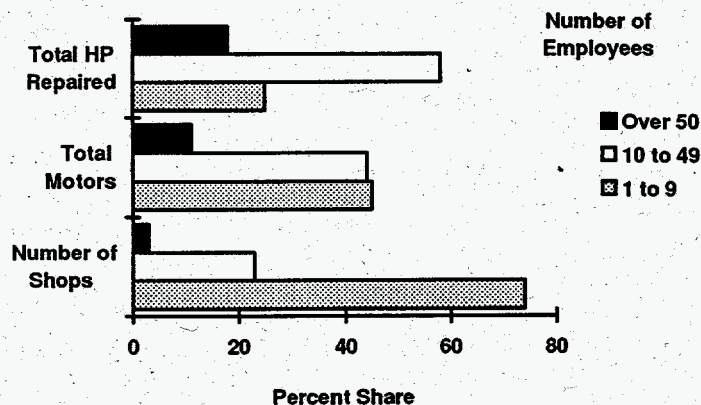
There are approximately 4100 motor repair shops in the United States. In 1993, these shops repaired between 1.8 and 2.9 million motors totaling over 200 million horsepower.

The Electric Power Research Institute's (EPRI) 1985 estimate that there are 19 million motors over 5 hp suggests that existing motors are repaired or rewound at 5-to-7 year intervals.

These shops had \$2 billion in gross annual motor repair revenues, which is approximately two-thirds of the shops revenues from all sources (\$2.75 billion). As a point of reference, members of the National Electrical Manufacturers Association (NEMA), which includes companies that manufacture products for the generation, transmission, distribution, and use of electricity, have annual shipments for all products of approximately \$100 billion.

The motor repair industry is dominated numerically by small shops; however, larger shops have the biggest share of the market as they are likely to repair more and larger motors. Three quarters of the shops had ten or fewer employees. These smaller shops repaired 45 percent of the total motors and 25 percent of the total horsepower.

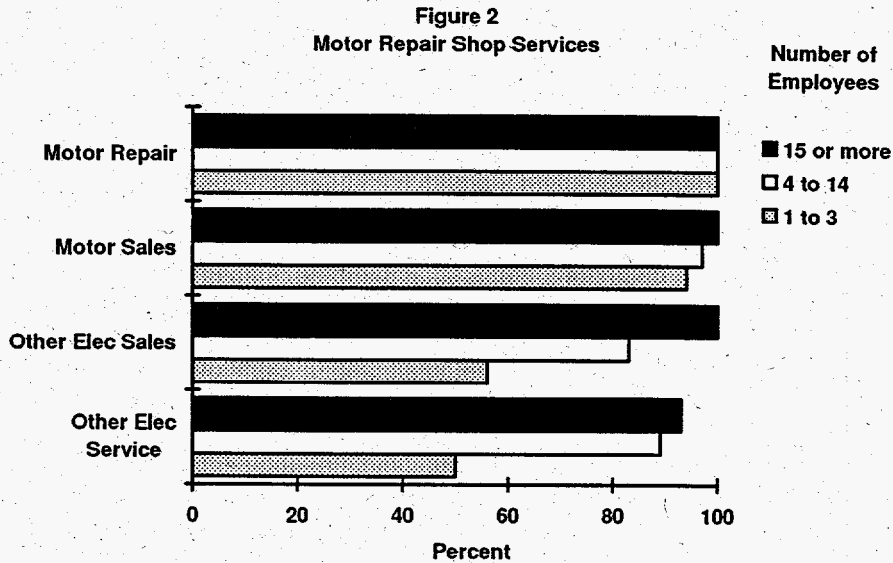
Figure 1  
Share of Motor Repair Market  
By Size of Shop



Slightly under half (47 percent) of motor repair shops are members of the Electrical Apparatus Service Association (EASA), the repair industry's largest trade association. Non-EASA shops tend to be smaller and repair fewer motors at lower horsepower. EASA shops repair 65 percent of total motors and 75 percent of total horsepower.

## Service Structure

Figure 2 summarizes services provided by motor repair shops. All the shops interviewed provided some service other than motor repairs and rewinds. Ninety-five percent sold new motors and four out of five sold or serviced other electrical equipment.



Although repair shops provide other services, motor repair accounts for 70 percent of their gross revenues. Non-repair services contribute a larger share to the revenues of larger shops. For shops over 50 employees, motor repair generates 50 percent of gross revenue, compared to 70-75 percent for smaller shops. One reason for this is that small shops are less likely to sell or service electrical equipment other than motors. Half the smaller shops, compared to nearly 100 percent of the larger shops, sell and service equipment other than motors.

Fifty-four percent of the shops contract out some work (Table 1). Machine work, formed coils, balancing, and small armature work was contracted out most frequently.

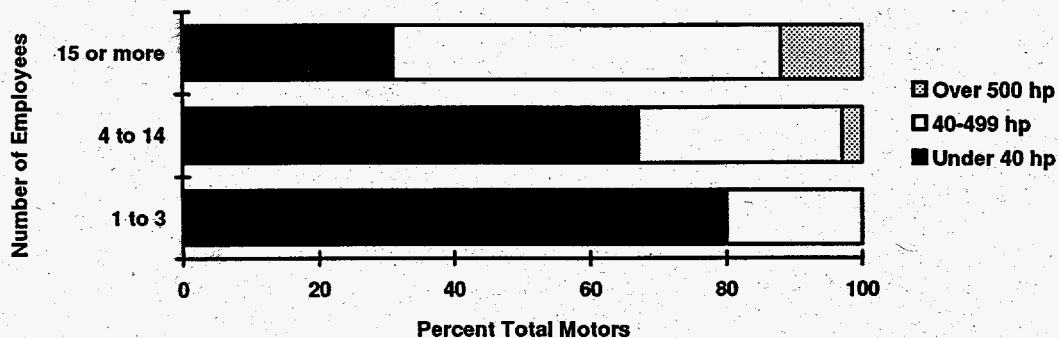
**Table 1**  
**Percent of Shops Reporting Work Contracted Out**  
(N=65)

<b>Any work contracted out</b>	54%
Machine work	26%
Formed coils	10%
Balancing	6%
Small armature work	5%
High voltage motors	3%
Large motors	3%
Rotor balancing	3%
Welding	3%
Vibration testing	3%
Vacuum Pressure Impregnation (VPI)	3%

On average, 80 percent of the motors repaired by shops were AC polyphase, regardless of shop size. The largest reported share of repair work represented by DC motors was 40 percent at one shop.

Larger shops are much more likely to repair larger hp motors (Figure 3).

**Figure 3**  
**Mean Percent of Motors Repaired by HP Range**



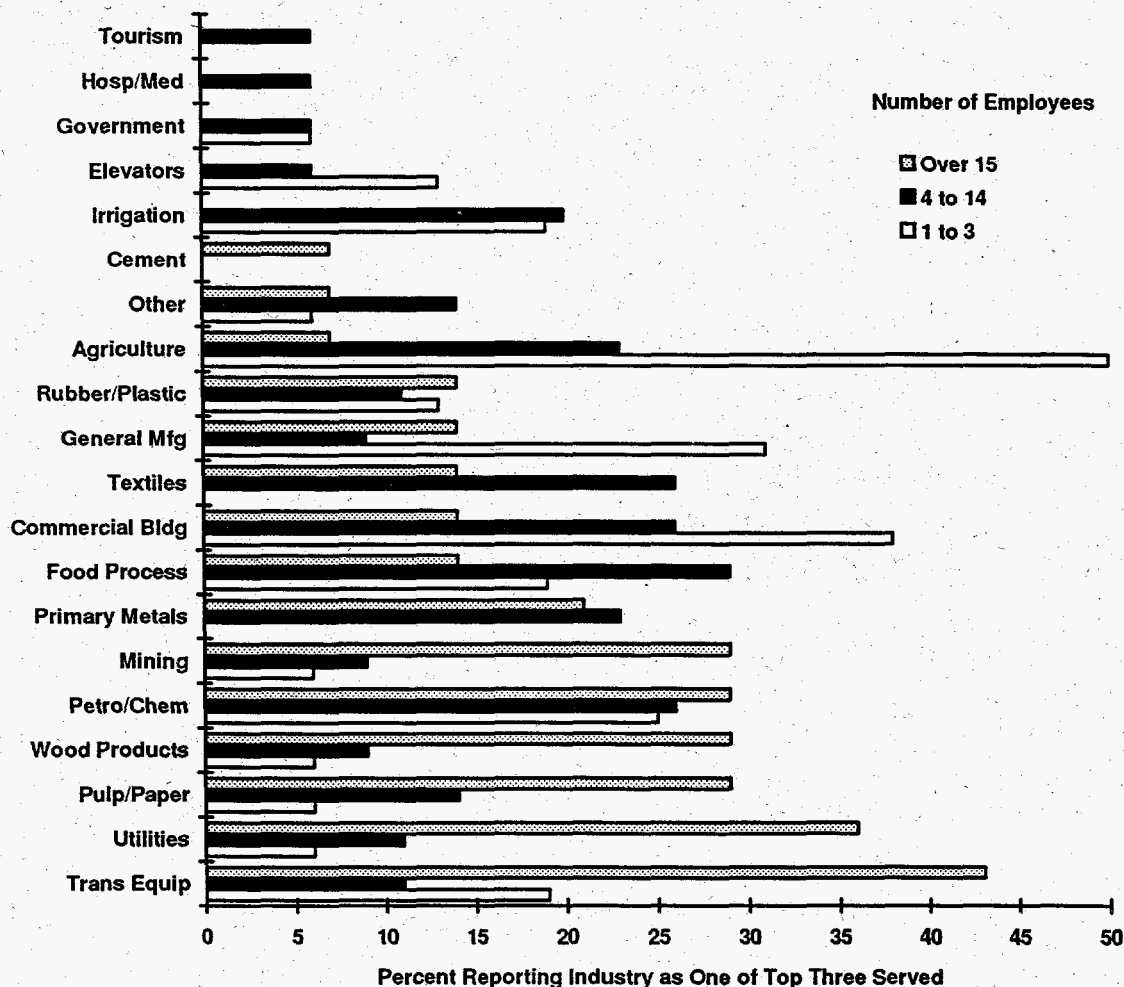
Motor repair shops are very stable and are often family businesses. The median length of time the shops surveyed had been in business was 25 years (Table 2). Larger shops have longer business histories.

**Table 2**  
**Median Number Years in Business**

	<u>Years in Business</u>
All Shops (N=65)	25
<i>Number of Rewind Employees</i>	
One to Three (N=16)	19
Four to Fourteen (N=35)	29
Over 15 (N=14)	39

The shops repaired motors for a broad spectrum of industrial and commercial clients. Smaller shops were more likely to work in the commercial, agricultural and general manufacturing sectors. Large shops dominate transportation, manufacturing, and heavy industry sectors. This is not surprising since motors in these sectors are larger and more complex and require equipment and expertise small shops do not have. Figure 4 summarizes the industries shops reported as being their top three sources of repair business.

Figure 4  
Major Industries Served by Shops  
in Sample



Two-thirds of the shops provide planned maintenance and inspection services to some clients. According to one motor repair customer, many of the motors sent out for planned maintenance do not get repaired. Most are sent for cleaning, inspection and balancing (Nailen 1993). Planned maintenance accounted for 5 percent of the total motor service business for the median size repair shop. Large shops are more likely to service motors on planned rotation. Almost one-quarter of the motors serviced in shops with more than 15 employees are on planned maintenance. **Planned maintenance accounts for only 10 percent of the motor repair market.**

# What the Customer Wants--Motor Repair Industry Perspective

We asked motor repair shops to rate the importance of factors their customers use to select a repair shop. We used a four-point scale where one means the factor is not important and four indicates it is very important. Ratings are summarized in Table 3.

Three selection criteria were rated as very important by almost all the shops. These are factors that all shops feel their clients value and understand. They include fast turn-around time, quality control and reliability, and the technical skills and expertise of the staff.

Three selection criteria were rated very important by about half of the respondents: the range of repair services offered, quality of material used, and the length of the working relationship. These were factors the shops felt were important and understood by some of their customers. Large shops were significantly more likely to rate the quality of materials and range of service as very important to their customers.

Low cost was rated very important to customers by only one-third of the shops. This low rating may reflect the shops' association of low cost with poor quality. They may also reflect shop preferences for the criteria customers should use to select repair shops. It was evident in comments throughout the survey that most shop owners have a strong craftsman ethic and pride in getting good work out despite the rapid turn-around times required by their customers. Shops understand that when a critical component (motor) fails, it must be returned to service as quickly as possible, regardless of the cost, to avoid even more costly downtime for their customers. Finally, the low rating for costs does not mean that shops are not aware of the pressure to reduce costs relative to replacement or that cost issues are not important to clients. Instead, it means that once the decision to repair is made, shops believe that clients are willing to pay to have it done right and on time.

Information and reporting on motor repairs and training support services were rated the least important services to customers. Larger shops were more likely to rate these factors as more important.

Those interviewed indicated that customers did not choose shops based on their ability to maintain energy efficiency during repair or their experience repairing premium efficiency motors. The maintenance of energy efficiency was not introduced as a rated factor in the questionnaire, and none of the respondents mentioned it unaided. **Shops reported that customers seldom provide any repair specifications, much less specifications for maintaining energy efficiency and that their clients often do not have the information or background to identify and specify quality motor repair work.**

Table 3  
**Motor Repair Shop Ratings of  
 Reasons Their Customers Choose Repair Shops**  
 1= Not Important --> 4= Very Important

Factor	<u>N=</u>	<u>Average Rating</u>	<u>Percent Rated Very Important</u>
Fast turn-around time	65	3.78	82%
Quality control/reliability	65	3.78	82%
Technical skills/staff expertise	65	3.71	72%
Range of repair service offered	65	3.52	57%
High quality materials/components	65	3.35	55%
Length of working relationship	65	3.32	52%
Low cost	65	3.11	32%
Information and reporting on repairs	64	2.56	20%
Training and support services	62	2.40	14%

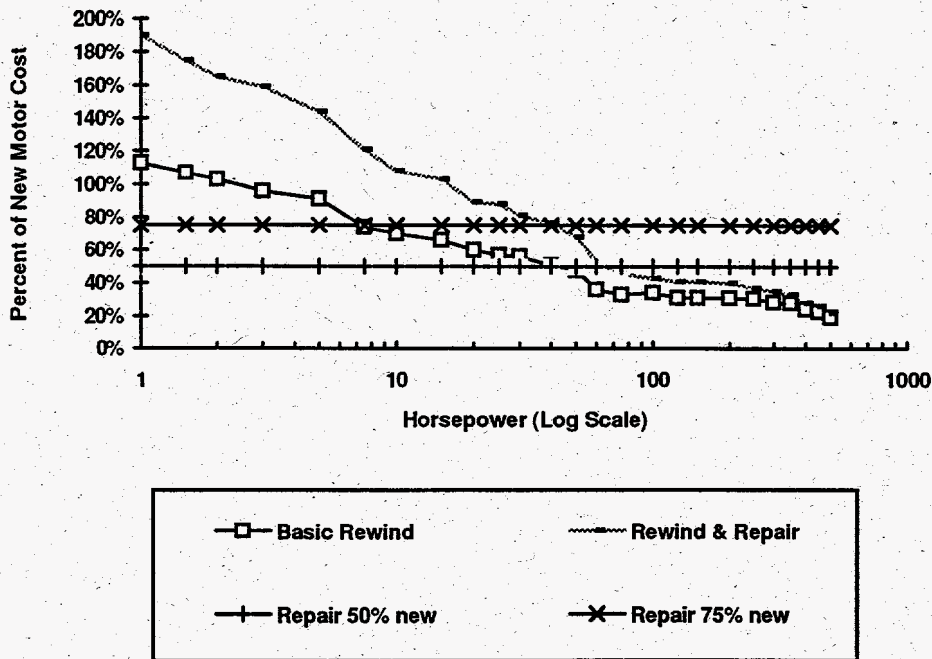
## Recent Developments

### Motor Repair Industry Trends

The motor repair industry is in a state of transition. In a 1993 member survey sponsored by EASA, almost three quarters of those surveyed reported their profitability had decreased over the past two years. Shops attributed decreased profitability to increasing labor costs, a decreasing market for repair work, high tech specifications, increasing costs for meeting government regulations, and dealing with customers more sophisticated demands for services. (Brutlag and Associates 1993).

One reason the market for motor repair is declining is that the break-even point for replacing rather than repairing motors is shifting to larger motors. Motor users will often purchase a new motor if repair and rewind costs are 50 to 75 percent of new motor costs. To illustrate this, we have compared the ratio of rewind costs to new purchase price for 1800 RPM Totally Enclosed Fan Cooled (TEFC) T frame motors using data from *Vaughens Complete Price Guide, 1994 (Figure 5)*. We compared costs for a standard rewind and a rewind that includes some additional repair work (furnish and install two standard bearings and nine new leads). The break even point for replacing a motor rather than rewinding a motor for non-specialized applications is between 5-10 hp (Vaughen's 1994). If any additional repairs are needed the break-even point is between 10 and 20 hp. When the energy savings of buying a premium efficiency motor over standard efficiency and utility rebates are factored in the break-even point shifts to larger hp motors. A more sophisticated analysis that includes these factors is planned for the Energy Efficient Motor Repair Guidebook being prepared by WSEO.

**Figure 5**  
**Rewind and Rewind/Repair Cost as a Percent of New Motor Cost -- 1800 RPM, TEFC Standard Efficiency Motors**



Source: Vaughen's (1994)

According to Mehta (1994), the repair/replace decision point appears to be moving towards larger hp motors because of increasing repair costs. In high priced labor markets such as Hawaii, the break even point may be as high as 40 to 50 hp.

The motor repair shops we surveyed verified these facts. When asked to describe the major challenges facing the motor repair industry, shops most frequently mentioned the general shift from motor repair to replacement, the eroding US industrial base, increasing costs of complying with government regulation, and increasing labor and equipment costs (Table 4).

**Table 4**  
**Major Challenges Faced by the Motor Repair Industry**

<i>Survey Respondents (multiple responses accepted)</i>	<i>(N=62)</i>
Technology change/Shift to motor replacement	24%
Low cost new motors	21%
Weak economy/Declining industrial base	18%
Environmental/Government regulations	18%
Increased costs for labor, equipment and materials	16%
New energy efficiency standards	10%
Competitive market	8%
Other	19%



Repair shops are under tremendous pressure to reduce costs, improve quality assurance and technical services, and reduce lead times. At the same time, the mix of motors that shops are asked to repair is changing with increased penetration of premium efficiency motors.

## **Premium Efficiency Motors**

### **Market Penetration**

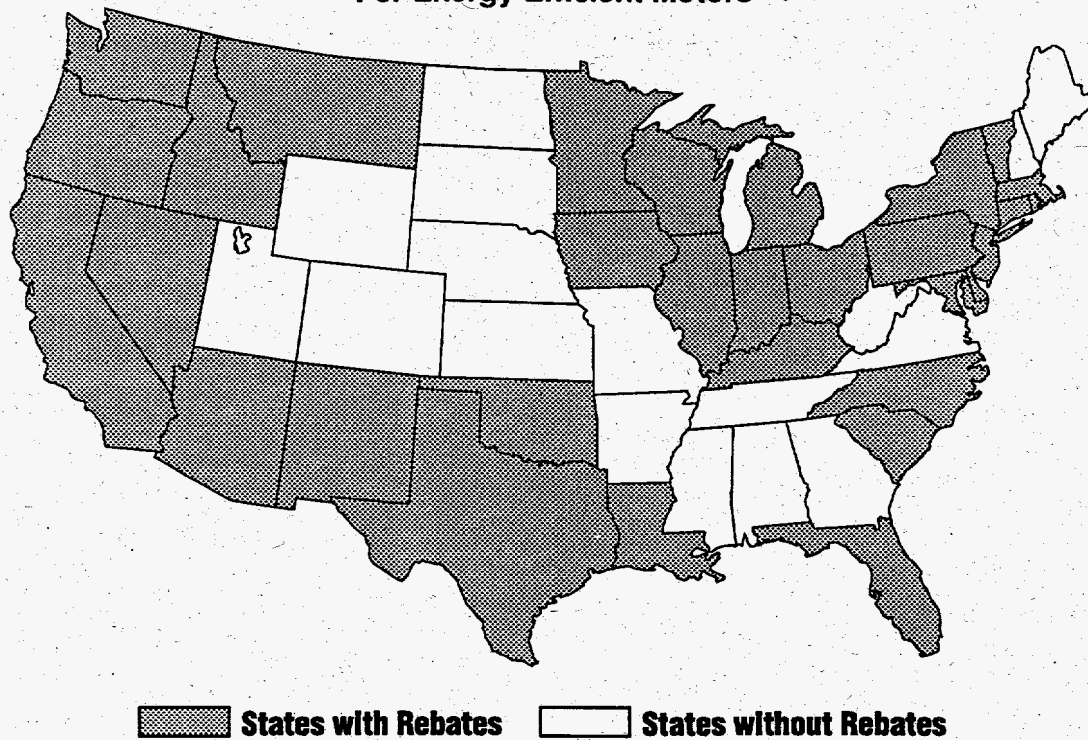
The penetration of premium efficiency motors is increasing. In 1990, EPRI estimated that about 20 percent of new motors sold over 5 hp could be classified as energy efficient (meeting NEMA 12-9) and that by the year 2000 motors meeting NEMA's 12-9 standard could account for two-thirds of new motor sales (EPRI 1992). National projections of the penetration of premium efficiency motors (meeting NEMA 12-10) are not available. They are expected to be one-half to one-third the penetration of "energy efficient" motors. There are strong regional variations in market penetration. Fryer and Stone estimated energy efficient motors had a 25 to 30 percent share of new motor sales in four New England states which have aggressive utility rebate programs. Of motors currently in production and listed in the January 1994 version of MotorMaster (nearly all motors available in the U.S.), 44 percent are premium efficiency (meeting NEMA 12-10) and 58 percent are energy efficient (meeting NEMA 12-9).

Because of the lag between motor sales and repair, premium efficiency motors have not yet made a strong appearance in the motor repair market. In our survey, the median shop reported less than 5 percent of repaired motors were energy efficient. Only one shop in fifteen reported that energy efficient motors accounted for at least one quarter of their work. These proportions are overstated since shops have difficulty distinguishing energy efficient motors from standard efficiency motors.

### **Utility Rebate Programs**

The share of premium efficiency motors will increase since many electric utilities offer programs to encourage the purchase of these motors. As of 1993, more than 160 utilities in over 30 states offered rebates or other incentive programs (EPRI 1993).

Figure 6  
States with Utilities Offering Rebates  
For Energy Efficient Motors



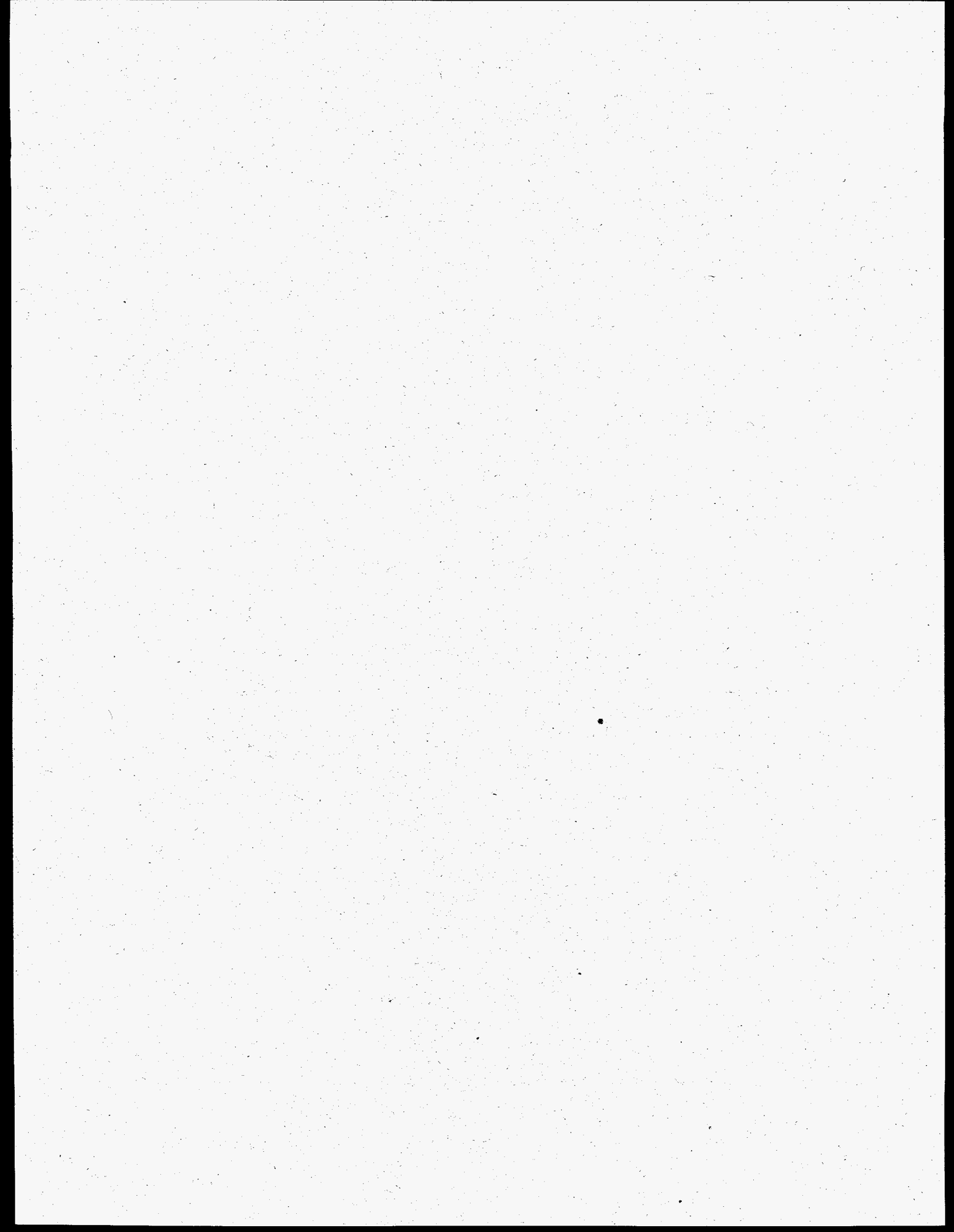
Source: EPRI (1993)

Shop experience with rebate programs for motors was mixed. Forty-five percent of the shops reported that utilities serving their customers offered rebates.

Utility programs that encourage new premium efficiency motors are likely to have two impacts on the motor repair market. First, to the extent that rebates reduce motor first costs, these programs encourage motor replacement over repair. In addition, some utility programs also require scrapping the replaced motor. Actual impacts on the demand for motor repair have not been documented. Half of those surveyed who had rebate programs in their service territories reported that their business was effected. These responses are based more on speculation than experience because premium efficiency motors represent only 20 percent of new motor sales.

The impacts of utility rebates on motor sales and repair are most pronounced on motors under 50 hp. Smaller shops feel particularly hard hit since they are more likely to repair small motors and are not able to compete as successfully for sales of new premium efficiency motors. Manufacturers offer list price discounts to distributors based on annual sales. Larger volume shops can sell motors at lower prices.

A second impact is the growing demand for energy efficient repairs among utilities. As a consequence, repair shops have become more interested in strategies for maintaining energy efficiency during repair as a means to maintain market share. However, the importance of maintaining energy efficiency during the repair of all motors is not yet broadly established in the repair industry. Interviews during shop site visits suggested that many shops believe it is only important to maintain efficiency when repairing premium efficiency motors. In fact, it is important to maintain original efficiency in standard motors as well as premium efficiency motors.



## Chapter 3

# Energy Savings Potential

## Sources of Decreased Efficiency During Motor Repair

Comprehensive studies on the magnitude and causes of decreased efficiency after motor repair are not available. In our review of the literature, we found five empirical case studies of efficiency loss in motor repair covering 52 motors. Most motors tested were under 100 hp. These case studies can be used to illustrate what can happen as a result of repair, but cannot be extrapolated to predict efficiency losses for all repaired motors. Results are summarized in Table 5.

**A range of decrease in full load efficiency between 0.5 percent and 2.5 percent was reported.** These estimates converged on an average decrease in efficiency of 1 percent after initial rewind. Losses over 4 percent are uncommon and would be associated with premature motor failure. Testing by Powertec Labs in British Columbia, Canada (Zeller 1992) suggested that decreases in efficiency for premium efficiency motors may be lower (between 0.5 and 0.7 percent). The Zeller study found larger decreases in efficiency for motors under partial loads; the Ontario Hydro study found lower decreases.

Only one study of two motors examined the impact of multiple rewinds. In the study, the efficiency of one motor declined 2.2 percent after four rewinds. Efficiency declined .4 percent in the second motor.

**There is little empirical data on the efficiency impacts of rewinding large hp motors.** It is likely that efficiency losses are somewhat lower with large motors because they are repaired in large shops, which are likely to have appropriate diagnostic equipment, parts, and quality assurance procedures. More research is needed in this area.

**Table 5**  
**Empirical Studies of Efficiency Loss During Motor Repair**

Study	Sample Size	Decrease in Full Load Efficiency	Comments
McGovern (1984)	27	1.5 - 2.5%	Motors ranged from 3 to 150 hp - Wide range of motor age and rewind histories General Electric.
Colby and Flora (1990)	4	.5 - 1.0%	Standard and Premium 5 and 10 hp motors. North Carolina.
Zeller (1992)	10	.5% Rated Load .7% 3/4 Load	Controlled test. Identical 20 hp Premium Efficiency Motors Shops in British Columbia.
Ontario Hydro (1991)	9	1.1 % Rated Load .9 % 3/4 Load	Controlled test. Identical 20 hp Standard Efficiency Motors. Shops in Ontario.
Ontario Hydro (1992)	2	40 hp 2.2% Rated Load 100 hp .4% Rated Load	Motors rewound four times each.

There are several potential sources for decreased efficiency during motor repair. Table 6 provides a short listing of these sources. See Appendix A for a more detailed discussion of efficiency losses.

Initial studies of efficiency losses (McGovern 1984; Seton, Johnson, and Odell 1987) focused on core losses. The 1984 EASA Core Iron Study established that two of five motors stripped in burn-off ovens set at 700° F and 750° F had core damage and reduced efficiency. The core iron of motors stripped at 650° F remained the same or improved (EASA 1992). Since then studies by Ontario Hydro, Colby and Flora, and Zeller have shown that core losses are not the only culprit in increased efficiency losses. In these studies, core losses decreased or increased marginally. Colby and Flora found that winding resistance increased significantly in two motors where the original concentric windings were replaced with lap windings. In the Zeller study windage and friction losses resulting from improper bearing replacements were a major contributor to decreases in efficiency in the motors tested. Stator I<sup>2</sup>R losses resulting from the use of smaller diameter wire during winding were an important contributor to total losses in one motor.

**Table 6**  
**Major Sources of Decreased Efficiency During Motor Repair/Rewind**

Action	Loss Type Impacted
Change in type of bearings	Windage and Friction losses
Change in type or size of fan	Windage and Friction losses
Excessive burnout temperatures (over 650°F)	Core losses
Core lamination damage during winding removal or repair	Core losses
Winding with smaller size wire	Stator I <sup>2</sup> R losses
Change in winding configuration	Stator I <sup>2</sup> R losses/Stray Load losses
Increased air gap	Stator I <sup>2</sup> R losses
Rotor bars cracked or loose	Rotor I <sup>2</sup> R losses
Degrade air gap symmetry (reduced rotor diameter, bent shaft)	Rotor I <sup>2</sup> R losses

The Zeller study segregated total losses by type of loss. Rotor losses were not a factor since none of the motors suffered rotor damage. Table 7 illustrates how the losses resulting from repair can interact and that significant increases in one type of loss can be off-set by decreases in other types. Thus, it is difficult to isolate one particular cause of decreased efficiency or identify one particular strategy to maintain energy efficiency during repair.

**Table 7**  
**Effect of Changes in Segregated Losses on Total Losses for Ten Repaired Motors**  
**BC Hydro HEM Rewind Study (1992)**

Motor	Core	Windage	Stray	Stator	Rotor	Total
A	---	II	---	---	---	---
C	II	---	I	---	---	---
D	---	III	III	---	---	III
E	---	III	II	---	---	II
F	---	III	D	---	---	---
G	II	---	I	I	---	---
H	---	I	---	---	---	---
I	III	---	---	III	---	I
J	D	III	---	D	---	---
K	I	II	II	---	---	---

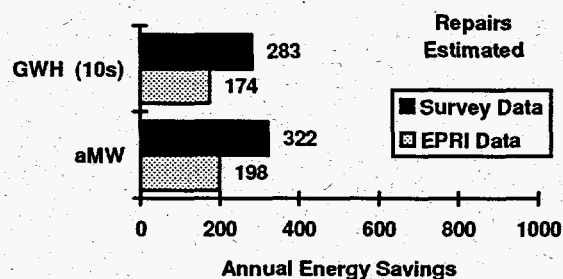
- III Relatively large increase after rewinding
- II Moderate increase after rewinding
- I Relatively small increase after rewinding
- Insignificant change after rewinding
- D Decrease after rewinding

Source: Zeller (1992)

# What is the Savings Potential

If all the motors under 500 hp that were repaired in 1993 were repaired with no increase in losses, electric energy end-use would decrease between 200 and 300 aMW a year (Figure 7). The difference in the two estimates depends on how the number of repaired motors is estimated. If all repaired motors currently in operation had no decrease in efficiency after repair, savings would be on the order of 2000 aMW. This is equivalent to two large power plants. Achievable savings are likely to be half or two-thirds of technical potential.

**Figure 7**  
**Technical Savings Potential**  
**For Motors Repaired in 1993 in GWh and aMW**



## Energy Impacts of Current Motor Repair and Rewind Practices

Technical savings potential was calculated by multiplying estimated percentage decrease in efficiency resulting from improper rewind by the number of motors repaired in the following two size ranges: 5 to 50 hp, and 51 to 500 hp.

The median hp within these bins were 25 and 150 hp, respectively. This median was used to calculate a median kWh impact in each bin using McCoy et. al.'s (1992) formula:

$$\text{kWh}_{\text{impact}} = \text{Hours of operation} * \text{hp} * \text{Load} * .746 * (100/(E - IL) - 100/E) * \text{NMR}$$

Where:

Load = Average motor load. Assumed at 75 percent of full rated load.

E = Nominal Efficiency Rating for 25 and 150 hp Standard and Premium Efficiency Motors.

IL = Change in efficiency (percent).

NMR = Number of motors repaired.

Key assumptions for estimating national kWh impacts from efficiency decreases after repair are documented in Table 8.

**Table 8**  
**Key Assumptions Used In Calculating kWh Impacts by Motor hp**

Parameter	Motor Size Bin		Source
	5 to 50 hp	51 to 500 hp	
Median motor (hp)	25	150	EPRI (1992)
Average standard motor efficiency (%)	89.3	93.0	McCoy (1992)
Average premium motor efficiency (%)	92.5	95.0	McCoy (1992)
Premium motors share (%)	5	5	Current Survey
Annual Operation (hrs)	2628	4380	EPRI (1992)
Load	.75	.75	
Decrease in Efficiency (%)	1.0	.5	
Number of Motors Repaired in 1993			
EPRI Data	1,367,000	520,482	EPRI (1992)
Survey	1,890,000	910,000	Current Survey

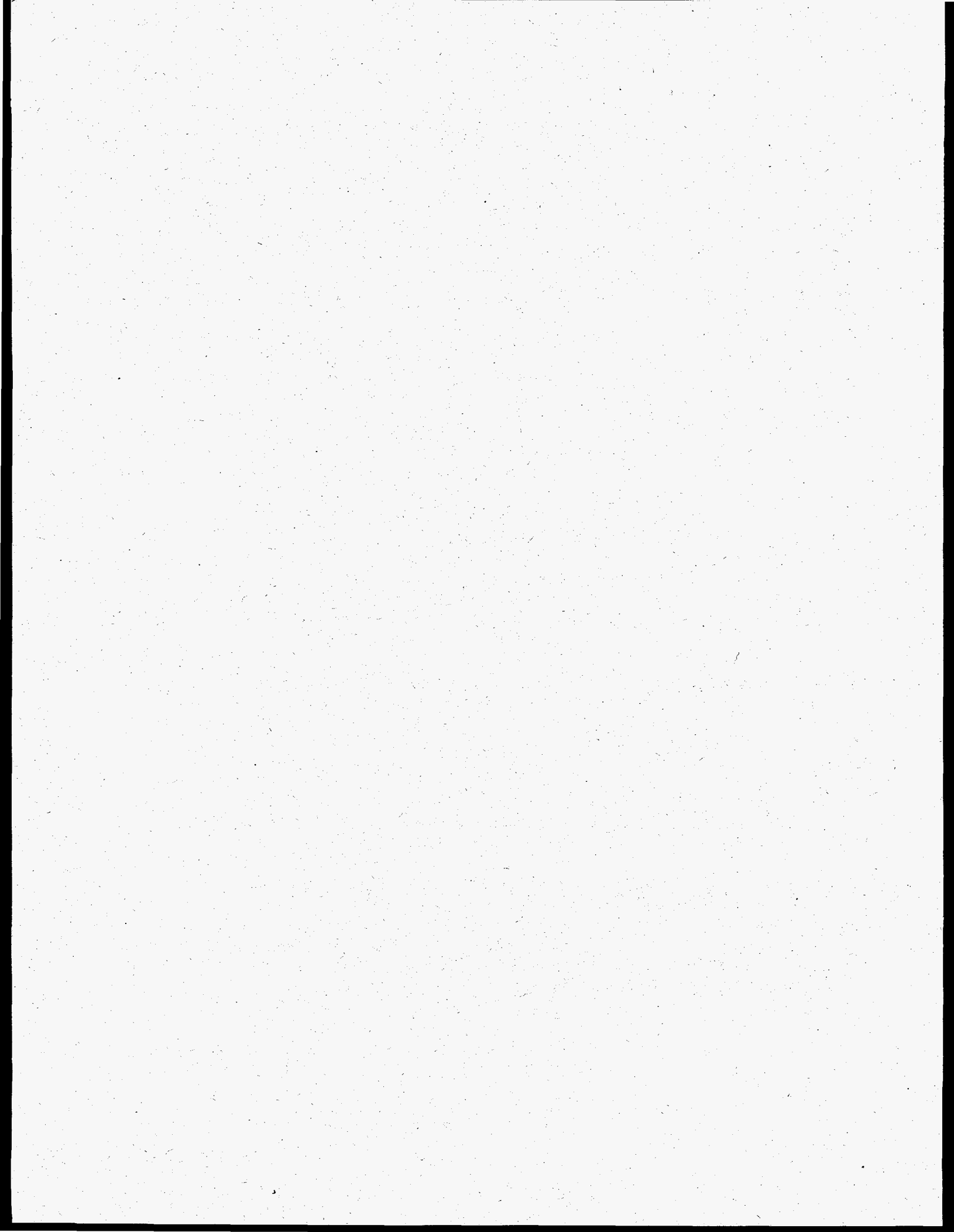
### **The Motor Repair Population**

One source of uncertainty in estimating potential energy savings is the number and distribution of motor repairs. We estimate that in 1993 between 1.8 and 2.9 million motors between 5 and 500 hp were repaired. No comprehensive data exists on motor repair and rewind rates. Estimating motor repair rates is complicated because of problems defining what a repair is. All repairs do not require rewinds or other work that could result in decreased efficiency. Therefore, the more conservative estimate may be reasonable.

We used two approaches to estimate motor repair levels. First we calculated the median number of rewinds by horsepower for small, medium, and large shops as reported in the survey. These were multiplied by the estimated number of shops in each size category. As a reasonableness check, we extrapolated EPRI estimates of the 1985 national motor population to 1993 levels (EPRI 1992). We assumed that 40 percent of motors between 5 and 20 hp, 75 percent of motors between 20 and 50 hp, 90 percent of motors between 50 and 125 hp, and 95 percent of motors over 125 hp are repaired. These proportions are consistent with motor repair penetration data developed by Fryer and Stone (1993) for the New England area. We also assumed that motors are repaired on average every seven years. This is the high end of the 5-to-7-year estimate of repair cycles developed from the survey data.

According to USDOE estimates, motors have technical lifetimes between 15 and 30 years, where motor life is calculated as design life divided by annual operating hours (USDOE 1980). However, for many motors the time to rewind or redesign is shorter because of poor operating conditions and changes to the drive systems and processes to which the motor is connected. Andreas (1992) suggests that 5 to 10 years is a reasonable range for the operating lives of motors in a given application. Motors may be rebuilt and reused in a different application or kept as spares.





## Chapter 4

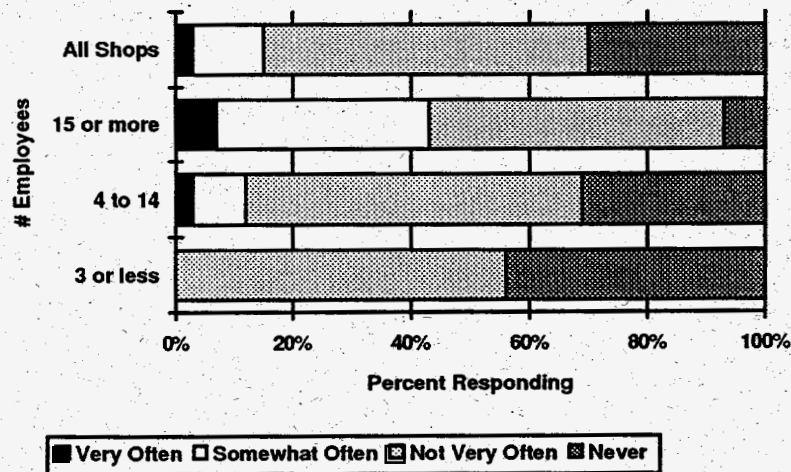
# Motor Repair Practice

## Motor Repair and Quality Assurance Specifications

### Specifications from the Customer

Most customers do not use repair or quality assurance specifications. Only 15 percent of motor repair shops indicated that they very often or somewhat often get repair specifications from customers beyond the requirement to return the motor to its original condition (Figure 8). Large shops were much more likely to see customer repair specifications.

Figure 8  
How Often do Customers  
Provide Repair Specifications?  
(N=65)

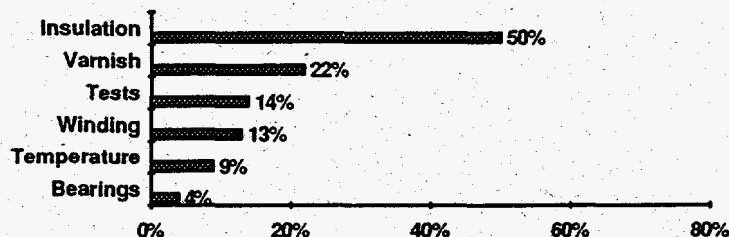


The most common customer specifications reported by shops were for insulation levels, varnish, winding patterns, or for meeting special operating conditions such as high temperatures or corrosive environments (Figure 9). No shops reported customer specifications for energy efficient repair. The larger shops observed that they get more detailed specifications sheets from larger clients, but that detailed specifications were the exception not the rule.

There are no model industry standard specifications for energy efficient repair of motors. A possible exception is IEEE Std 1068-1990, "IEEE Recommended Practice for Repair and Rewinding of Motors for the Petroleum and Chemical Industry," which is used in the petrochemical industry for large motor repairs and addresses some quality repair issues.

The International Organization for Standardization's ISO 9000 standard is widely accepted in the industry as the framework for Quality Assurance standards, but it does not address motor repair specifically. In 1992, EASA developed broader quality assurance specifications, known as the EASA - Q standards, based on the ISO framework. EASA - Q covers some elements of rewind practice, but does not address maintaining energy efficiency comprehensively. The Canadian utilities and the limited number of United States utilities working to improve quality assurance practices in motor repair shops indicated that the EASA-Q and ISO standards are a sufficient framework. Existing standards could be improved. Developing a new standard specifically targeted to energy efficiency is not warranted.

**Figure 9**  
Types of Customer Specifications Reported  
(N=46)



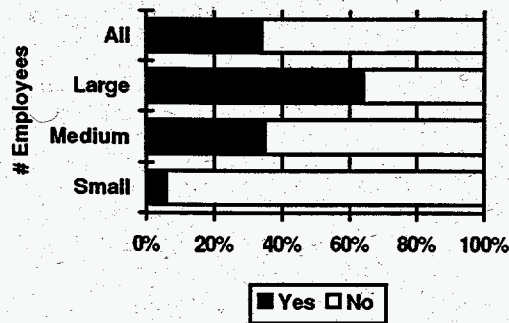
Most shops take their craft seriously. Although customers rarely specified requirements beyond returning the motor to its original condition before failure, 95 percent of those surveyed reported that, in some cases, they improved on the original motor specifications, and motors left the shop with better components than they had before they failed. The most frequent upgrade mentioned was insulation class (81 percent), followed by better workmanship in general (29 percent). Other routine upgrades from original condition included higher quality bearings (15 percent), higher quality wire (10 percent), balancing (11 percent), and testing in general (8 percent). Many of the respondents interpret original condition as meaning the condition of the motor as it was repaired or rewound before it failed and not its factory original design. A number of shops reported that sometimes the improvements were necessary to correct motors that had been poorly repaired elsewhere.

Most shops (69 percent) do not offer more than one repair package to clients. Most do not offer special packages with better components or more testing. The shops that do offer alternative repair packages did not differentiate by the level of quality or extra features. Forty percent (12 percent of the total) offered a rush repair package. About half of those (6 percent of the sample) report they used short cuts (pour-on varnish or open flame burn-outs) on rush jobs. Of those offering multiple repair packages, 30 percent said they provided partial repairs (for example, bearing replacements). Twenty percent have special packages for motors used in environments where conditions are extreme.

### Written Repair and Quality Assurance Standards

Two of five shops surveyed used written repair guidelines of any type. One-third of the shops surveyed used written quality assurance procedures (Figure 10). What shops considered written procedures covered a wide range. Five shops specifically mentioned EASA - Q, and three mentioned ISO 9000. The remainder used standards they developed themselves. Only one in twenty small shops reported using written repair standards or quality assurance procedures.

**Figure 10**  
**Shops Having**  
**Quality Assurance Standards**  
**(N=65)**



Many shops, especially the small ones, did not appear to understand what a quality assurance guideline was and how it might be used. This was evident in the wide range of terms shops used to describe quality assurance procedures. Of the quality assurance procedures shops they used, 40 percent were repair procedure specifications, 25 percent were test specifications, and 21 percent were EASA standards. Only one of the 65 shops surveyed used any form of quality assurance testing. None of the shops reported using total quality management techniques.

## Motor Testing

One key element in maintaining energy efficiency during motor repair is basic diagnostic testing. Testing during repair in an energy efficiency context is done for three reasons:

- Diagnosing the nature of potential problems that need to be addressed during repair.
- Setting baseline conditions (particularly if original specifications are not available from the manufacturer).
- Confirming proper operation and that losses are within acceptable ranges.

Appropriate testing methods for a particular motor depend on several factors. These include whether the motor is operational, what caused the motor to fail, and what was repaired. The tests which should be done during motor repair are described in detail in Appendix C. Key tests for ensuring that a motor has been returned to original specifications are summarized in Table 9 below. Often more than one tool or approach can be used.

Table 9  
**Important Tests for Diagnosing Major Sources of Increased Losses**

Type of Loss	Diagnostic Tools
Windage and Friction	No Load Testing (At rated and reduced voltages)
Core losses	Core loss testing (Before/after rewind iron repair) Loop Test (Ring Test) Estimate from No Load Test
Stator Winding Losses	Winding Resistance Test Surge Test
Rotor Losses	Vibration testing (no load) Balance stand test for runout Growler and Feel Tests
Stray Load Losses	Difficult and costly to measure or isolate

### Testing Equipment

One indicator of testing frequency is whether shops have the appropriate testing equipment on hand. **Only the largest shops (those with fifteen or more employees) had a full compliment of testing equipment.** We classified testing equipment availability in three categories: basic equipment, specialty equipment, and equipment that is found mainly in large and medium shops (Figure 11).

Basic equipment is testing equipment that 85 percent or more of the shops reported having on-site. This equipment includes:

- Megohmmeters
- Low Resistance Ohmmeters
- AC High Potential Testers

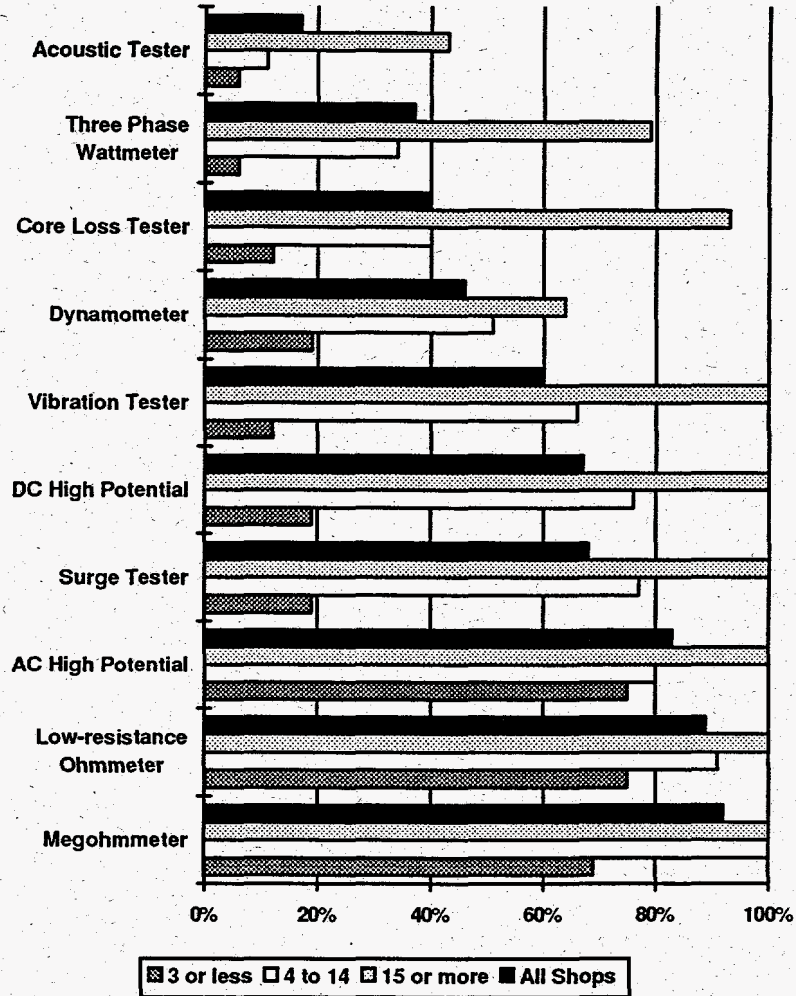
Specialty testing equipment was reported in about one-third of the shops surveyed. Forty to 80 percent of the large shops, 20 to 40 percent of the medium shops, and under 15 percent of the small shops had this equipment. Specialty equipment includes:

- Dynamometers
- Core Loss Testers
- Three phase Wattmeters
- Acoustic Testers

Not all the dynamometers and core loss testers reported were commercial units. Some used homemade test beds or simply hooked up a shaft to a brake. The remaining testing equipment was found in all large shops, two-thirds of the medium shops, and in 15 to 20 percent of small shops. Two-thirds of all shops have this equipment on site:

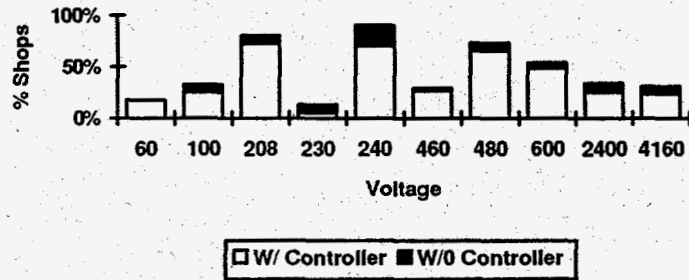
- Vibration Testers
- DC High Potential Testers
- Surge Testers

**Figure 11**  
**Percent of Shops Having Test Equipment**  
**Total and By Number of Employees**  
**(N=65)**



Four out of five shops (82 percent) have an auto-transformer or other controller capable of adjusting voltages to nameplate ratings during testing. As with testing equipment small shops were less likely to have voltage controllers. The range of voltages shops reported are summarized in Figure 12.

**Figure 12**  
**Range of Voltages Shops are**  
**Capable of Providing**  
**With/Without a Controller**  
**(N=65)**



### Testing Practices

Testing practices were not uniform among shops. Some of this can be expected because testing requirements are specific to individual motors and the condition in which they arrive in the shop. While it is difficult to specify a particular level of testing as the "right" level, few tests other than insulation testing were routinely done on all motors.

We asked shops to estimate what percentage of the motors they worked on were given each test. Since responses were approximate, we grouped them into five qualitative categories to simplify reporting in the remainder of this section. For example, in the next section on load testing, we report that one quarter of those interviewed rarely or never did No Load Power testing. This means one quarter of the shops reported they performed No Load Tests on less than 10 percent of the motors repaired. These categories are summarized in Table 10.

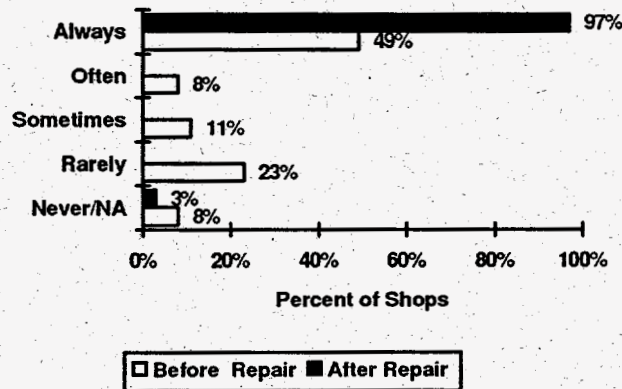
Table 10  
**Frequency Categories Used To Summarize Testing Data**

Frequency Category	Range Included
Almost Always	90 Percent or More
Often	50 to 89 Percent
Sometimes	10 to 49 Percent
Rarely	Under 10 Percent
Never	Zero

## No Load Power Testing

Ninety-seven percent of the shops reported they always did no load power testing after motor repair (Figure 13). Half the shops always did no load testing before motor repair, if the motor was operational. About one-quarter of the shops did this test rarely or never. The most frequent reasons for not running no load tests before repair were that the motor was not operational, the windings were clearly damaged, or only the stator was being repaired. Three shops reported that they did not do power testing in cases when power requirements exceeded their local supply. There were no significant differences in the rate of testing between large and small shops. This suggests that the condition of the motor, rather than shop capabilities or cost effectiveness is the main factor determining which motors are power tested.

Figure 13  
Frequency of  
No-Load Power Testing  
(N=65)

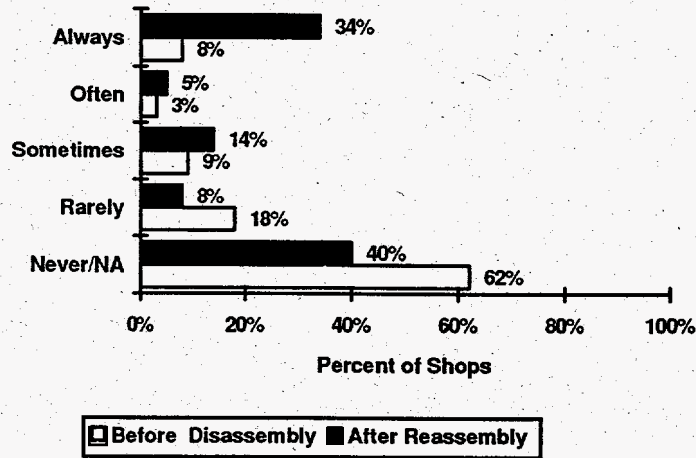


## Vibration Testing

Two-thirds of the shops surveyed reported they could do some type of vibration testing during repair (Figure 14). All large shops had this capability compared to half the small shops. Eighty percent of all shops rarely or never tested motors for vibration before disassembly. Testing for vibration after assembly was more common. Almost 40 percent of the shops reported doing vibration tests always or often after the motor was assembled.



**Figure 14**  
**Frequency of**  
**No-Load Vibration Testing**  
**(N=65)**

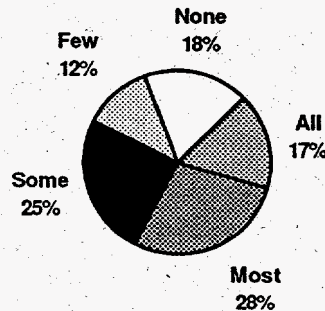


Vibration tests were not done for motors under 25 hp unless there was an obvious vibration problem, or the customer asked for the test. And as one would expect, shops were more likely to test high speed motors than lower speed motors.

Eighteen shops (27 percent overall or 42 percent of shops doing vibration testing) reported they relied primarily on judgment or "feel" rather than specific standards when determining acceptable vibration limits.

About half the shops said they checked the dynamic balance of rotors for all or most jobs (Figure 15). Shops were more likely to check dynamic balance on high speed (3600 RPM) motors, motors over 25 hp, or in cases where there were obvious vibration problems.

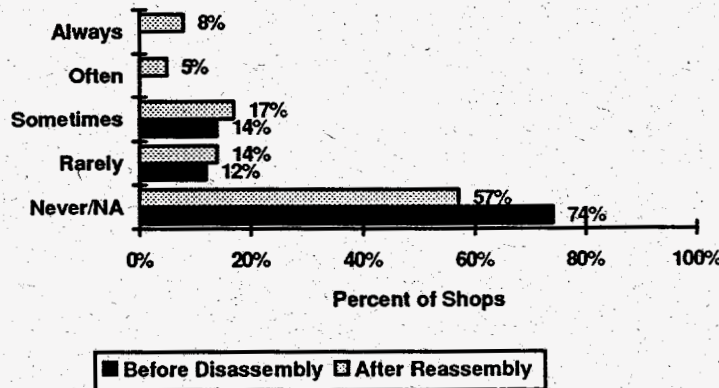
**Figure 15**  
**On How Many Jobs**  
**Do You Check the Dynamic Balance of**  
**Motor Rotors?**  
**(N=65)**



## Load Testing

Forty-seven percent of the shops did performance testing with a dynamometer or with the motor shaft coupled to a brake (Figure 16). Performance testing was very rarely done before disassembly and infrequently after reassembly. It was largely used at the customer request or in special circumstances, such as the repair of DC motors or when the repair job involved significant redesign. Fewer than one in five of smaller shops had the capability to do load tests. None of the respondents mentioned using the dynamometer to assess full load efficiency.

Figure 16  
Frequency of  
Load or Performance Testing  
(N=65)



## Insulation Testing

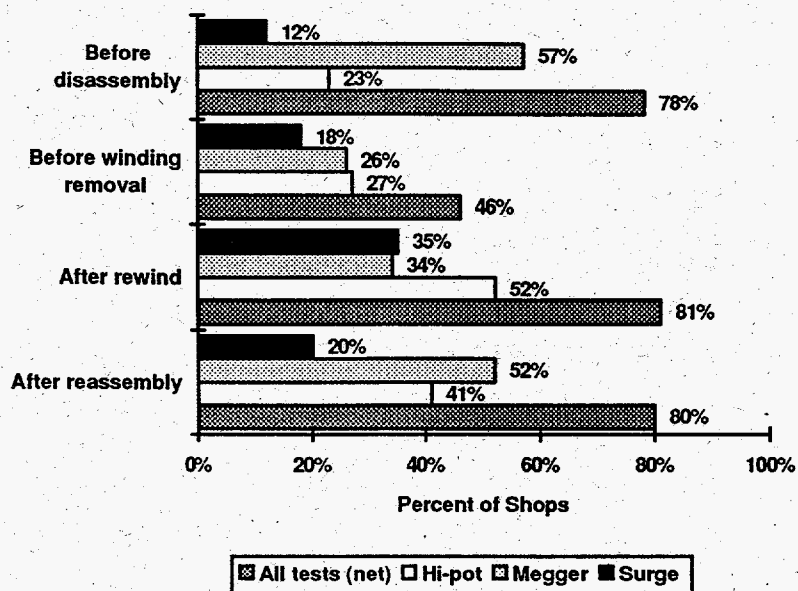
Repair shops view insulation testing as a fundamental step in motor repair. Ninety-five percent of the shops always or often did insulation testing (Figure 17). The only times insulation tests were not run was for clean-up jobs where insulation was not presumed affected, cases where obvious damage to the motor made the testing before disassembly irrelevant, or where moisture created potential safety problems.

Figure 17  
Frequency of  
Insulation Testing  
(N=65)



Shops test insulation three or four times throughout most motor repairs. Shops use a wide variety of testing equipment including AC and DC High Potential Testers, Megohmmeters, and Surge Testers. The more sophisticated shops conduct more than one type of test.

**Figure 18**  
**Frequency of**  
**Insulation Testing and the Use of Insulation Test Equipment**  
**(N=65)**



Shops used a wide range of techniques to determine the acceptable limits for insulation tests. Techniques ranged from very crude, "if the wire moves or if it pops," to the use of sophisticated testing standards.

### Winding Resistance Testing

Winding resistance tests are not performed routinely. Although two-thirds of the shops surveyed did winding resistance testing, only two of five did it always or often (Figure 19). One third of the small shops did winding resistance tests.

Figure 19  
Frequency of  
Winding Resistance Testing  
(N=65)

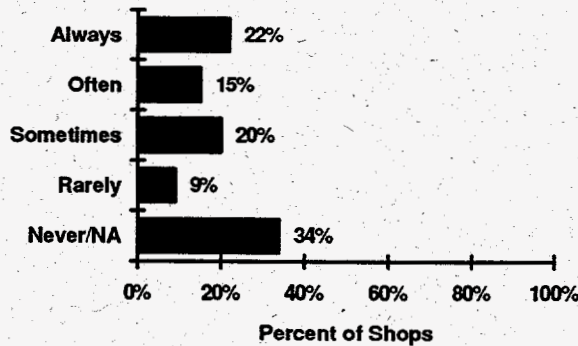
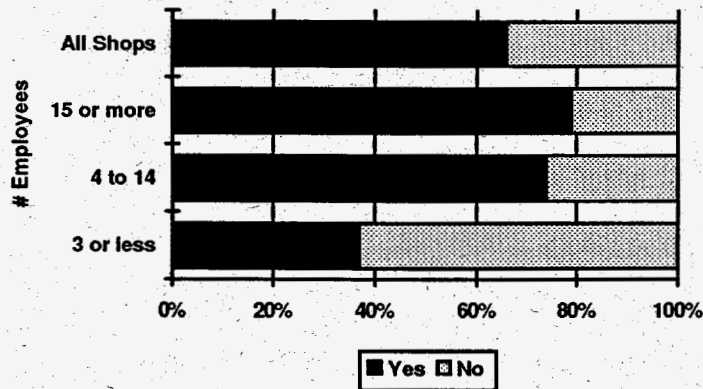


Figure 20  
Does Shop Measure Winding Resistance During Repair?  
(N=65)



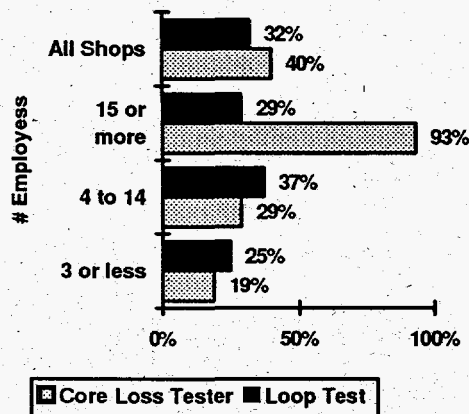
According to the shops, resistance testing is typically performed on DC motors and as a secondary test to troubleshoot problems with overload or current imbalance. Many shops appeared to view winding resistance testing as something that only applied to DC motors or to special problems. The most frequently mentioned time when resistance testing was done was after rewinding but before reassembly (42 percent), followed by before disassembly (23 percent), after disassembly but before rewinding (22 percent), and after reassembly (18 percent).

Eighty-five percent of those who could do winding resistance testing said they would do it routinely if the resistance data was on the nameplate or was easy to access via an electronic bulletin board or computer database.

## Core Loss Testing

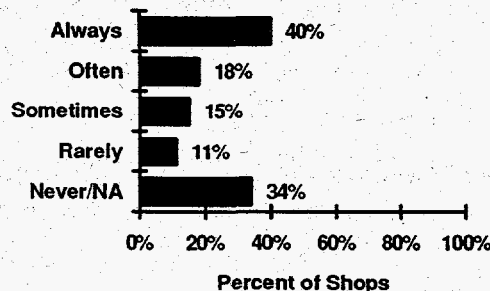
Two-thirds of the shops reported they had the capability to do core loss or loop ring tests. As with other testing practices the capability for testing is a function of shop size. Almost all large shops reported having a core loss tester, compared to less than one in five of the small shops. EASA's efforts to encourage core loss testing appear to have borne fruit. Almost half the EASA shops (49 percent) had core loss testers compared to 24 percent of the non-EASA shops (Figure 21). However, part of this difference may be because EASA shops tend to be larger than non-EASA shops and are more likely to have the financial resources to purchase a core loss tester.

**Figure 21**  
Does Shop Have Core Loss or Loop Test Capability?  
(N=65)



Core loss or loop tests were usually not done on small motors unless there was visible damage to the core iron. The cut off point used by most shops was about 25 hp, though three shops indicated they did not test for core loss on motors below 100 hp. Some shops said they skip core loss testing if the motor is fairly new or the repair does not involve a rewind or work on the core.

**Figure 22**  
Frequency of  
Core Loss or Loop Ring Testing  
(N=65)



Of the shops that did do core loss testing, most tested after disassembly and/or after winding removal (Table 11).

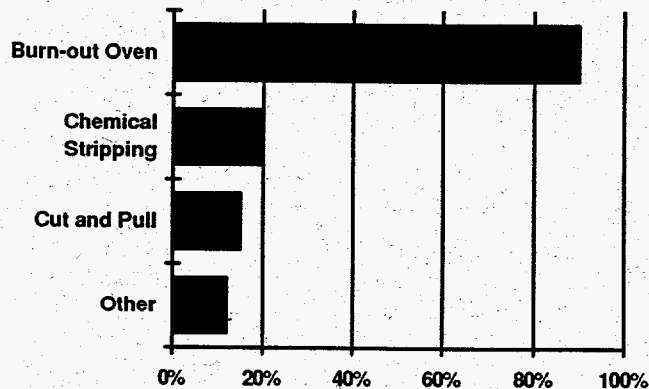
Table 11  
**When is Core Loss Testing Typically Done?**  
 (Multiple Responses Possible)

Testing Done (N=)	All Shops (65)	Shops Doing Core Loss Tests (43)
After disassembly	20%	30%
After winding removal	58%	88%
After new winding in place	8%	14%

## Winding Removal

Nine out of ten shops use a burn-out oven to remove old windings. Chemical stripping and cutting and pulling were used on some motors by 20 and 15 percent of the shops respectively. Ten to twenty percent of the windings in these shops were removed with these methods. Other methods reported were open fires (one shop), torches (one shop), air hammers and chisels (three shops), and one shop sub-contracted for winding removal.

Figure 23  
**Method Used for Removing Windings**  
 (N=60)



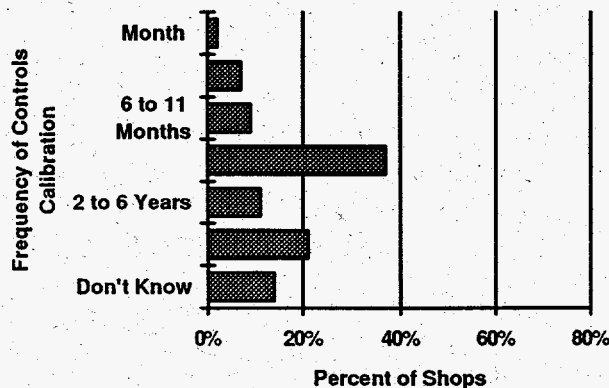
## Chemical Stripping

Chemical stripping and cut and pull are most often used for small motors and consequently are most used in smaller shops. Shops using chemical stripping use it about 35 percent of the time. For all shops, the average is about 6 percent. During site visits, shops indicated that concerns about health and safety and environmental regulations for chemical and hazardous waste disposal were the main reasons why they did not use chemical stripping more often.

## Burn-Out Ovens

Burn-out practices remain a problem. A significant fraction of the burn-out equipment is still primitive. Thirty-nine percent of the shops with burn-out ovens did not have water suppression systems. Ninety-five percent of the ovens had temperature controls. However, temperature sensors were placed in motor cores only 10 percent of the time. Temperature controls were not calibrated often (Figure 24). Fifty-five percent of the shops indicated they calibrated ovens once a year or more. Twenty percent indicated they never calibrated controls. As in other areas, larger shops had more sophisticated burn-out systems and were more likely to calibrate temperature controls.

Figure 24  
Frequency of Burn-Out Oven  
Temperature Control Calibration  
(N=57)

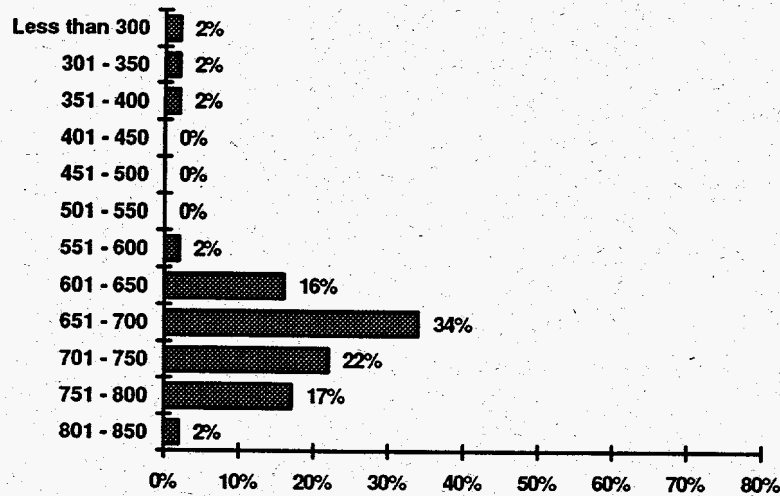


Burning out stators at temperatures above the 650° F threshold can increase core losses, particularly for older motors. This problem may be less severe for new motors with cores made with c-5 steel, which is less subject to problems with overheating.

Despite EASA's educational efforts, burn-out temperatures reported by many shops were significantly higher than the 650° F threshold. Three quarters of the shops reported typical burn-out temperatures over 650° F (Figure 25). Forty-one percent of shops had set points over 750° F. The median burn-out temperature was 700° F. This distribution is substantially the same as that reported for motor repair shops in the Pacific Northwest in 1987 (Seton, Johnson and Odell 1987).

One reason shops use higher burn-out temperatures is that it is more difficult to strip motors that have previously been rewound. Repair shops use numerous dips, bakes and epoxy when they rewind motors. These measures can be difficult to burn-out, even at 650° F. Also, epoxies can ignite during burn-off. This generates additional heat and can potentially damage the stator core. Some owners also questioned whether the extended burn-out time necessary at lower burn-out temperatures could be harmful to cores.

**Figure 25**  
**Typical Temperature Settings**  
**Reported for Burn-Out Ovens**  
**(N=58)**



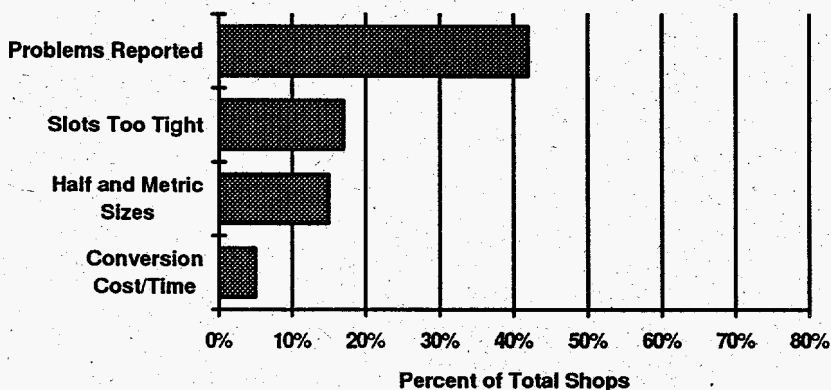
## Winding Practice

Shops were not asked if they rewound motors with less copper than the original specifications. As the Seton, Johnson and Odell (1987) pointed out, most shop personnel consider the suggestion that they rewind motors with less copper as a direct threat to their integrity. Motors are sometimes rewound with less copper, but it is difficult to estimate how often. Five shops indicated they added wire to previously rewound motors because they were under wound. Several shops interviewed expressed concern about adding copper even when there was room. Their comments were based on the concern that added copper would increase locked rotor and inrush current, which could over stress the motor user's protection equipment and distribution system.

Forty-two percent of the shops identified problems with winding motors with original size wire (Figure 26). Three major problems were cited: lack of room in the slots, the availability and cost of maintaining metric and half sizes of wire stock, and the cost and time to reengineer winding patterns when converting from non-standard wire sizes to sizes used in the United States. Most of these problems were associated with foreign motors.

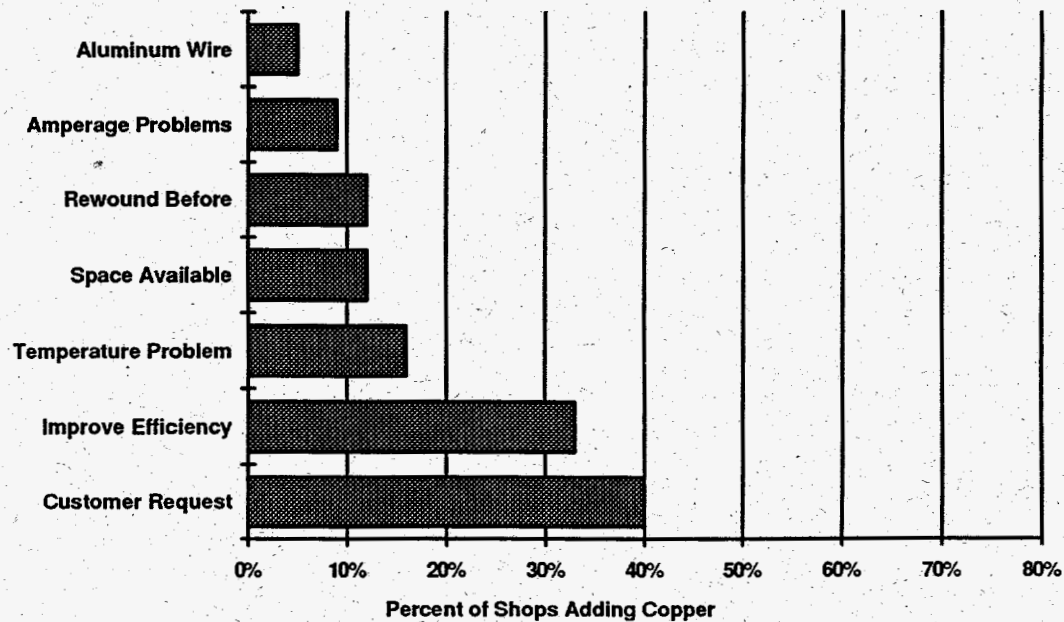


**Figure 26**  
**Shops Reporting Problems Winding With**  
**Original Wire Sizes**  
**(N=65)**



Although sixty-six percent of the shops reported they sometimes added more copper when rewinding standard T-frame and U-frame motors, this was done infrequently. The average shop added copper to less than 5 percent of the total motors they repaired. Shops added copper when the customer requested it or to deal with temperature or amperage problems (Figure 27). About a third of the shops did add copper when there was room. Five percent of shops indicated they replaced aluminum windings with copper when it was encountered (which is rare) or would add additional stranding to compensate for not having the correct wire sizes.

Figure 27  
 Why Is More Copper  
 Added During Winding?  
 (N=43)



Returning motor windings to original condition is difficult because manufacturer's winding data is not always readily available. **Eighty percent of the shops had difficulty obtaining winding data for some motors.** On average, shops reported that manufacturer's winding data was not available 37 percent of the time. Shops with three or fewer employees and Non-EASA shops reported even more difficulty. Sixty-six percent of the small shops, and 47 percent of the EASA shops, reported difficulty obtaining manufacturer's winding data.

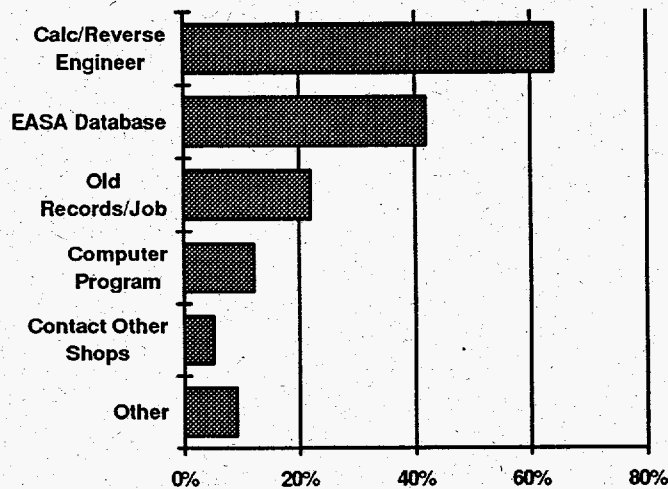
The reasons shops could not get winding data are summarized in Table 12. Shops cited two primary problems. The first is that manufacturer's data is not always available. Many, but not all the larger manufacturers provide winding data to repair shops. Shops mentioned that Toshiba and Baldor were very cooperative in this area. Shops had problems getting winding data from smaller and obscure "off-shore" motor manufacturers and for specialty motors in general. "Off-shore" motors are foreign motors not manufactured for the U.S. market. A second and more critical problem for shops is speedy access to the data. When working on rush jobs, shops need to have winding data immediately. Toshiba, which provides rewind data within one hour, was singled out as an example of good access. **Ninety-two percent of shops said they would use a service that provided winding data via phone or fax within an hour.**

**Table 12**  
**Reasons Manufacturer's Winding Data Is Not Available**  
**(N=48)**

Manufacturer's proprietary information	50%
Obsolete motors	19%
Availability of data for specialty/foreign motors	17%
Lack of time to track down winding data	15%
Cost of tracking down data	8%

Shops use several strategies in situations when winding data is not available. EASA shops make use of the EASA database and EASA support staff. A second source for shops is their own records and job cards for similar motors. The most frequently used strategy is reverse engineering windings by measuring the existing wire with a micrometer, counting turns, and observing the patterns. Or as one shop owner put it, "Calculate and experiment and waste a lot of time." Only about 10 percent of the shops used computer programs to assist them with reengineering winding patterns. Shops do not consider computer programs to be particularly reliable, and many shops are still not extensively computerized. Several shops reported they were reluctant to reverse engineer motors that had been rewound at other shops because they could not be certain that the previous rewind work had been done correctly. In these situations, shops preferred to track down the manufacturer's data even if it was not readily available.

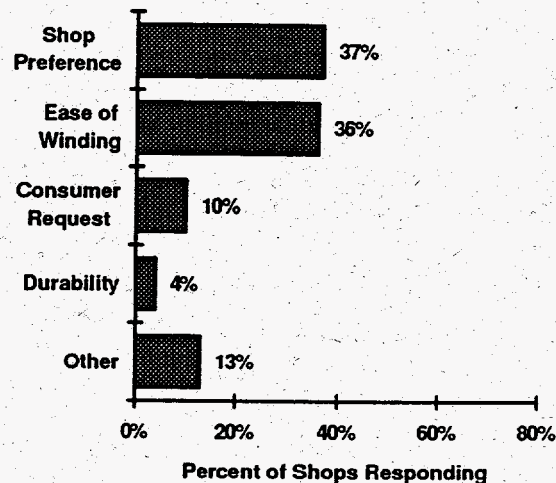
**Figure 28**  
**What Do You Do When**  
**Winding Data Is Not Available?**  
**(N=64)**



Eighty-one percent of the shops reported that they changed winding configurations. Winding configurations were most frequently changed because of shop preference or general ease of winding (Figure 29). Twenty percent of the shops changed to concentric windings in cases where fast turn-around was required. Two shops changed to lap winding because it was "more durable". At least 10 shops (15 percent of those surveyed) changed all windings to lap windings because of equipment limitations. Few shops indicated windings were changed because of customer requests or specific attempts to redesign motors.

Most shops do not consider energy efficiency when choosing winding patterns. Historically, their primary concerns have been torque, durability, and ease of winding. Most shops were not aware of the potential side effects of changing the winding configurations without testing or proper redesign. Only a few shops have the capabilities to test different windings in the shop and the tools to redesign windings. Further, there is very little published data on the efficiency impacts of changing winding patterns.

Figure 29  
Reasons Shops Change Winding Patterns  
(N=48)



## Bearings

We did not ask extensive questions about practices for replacing bearings and fans. Each of the before/after studies of motor repair mentioned earlier in this report did find that some bearings were changed during repair. As with winding data, it is difficult to get bearing and lubrication data from manufacturers in a timely manner. Bearing specifications are not straightforward, and shops often need to have more information than just the bearing number to get the information they need. Many shop owners do not keep extensive inventories of bearings on hand because of the cost. As with windings, shops need to obtain parts specifications and the parts quickly. Several shop owners reported problems obtaining bearing specifications, particularly for specialty motors. Some manufacturers use special and sometimes proprietary bearings that are not available to repair shops.

## Repair of Energy Efficient Motors

Motor repair shops do not have much experience with premium efficiency motors. Only one shop in 15 reported that at least 25 percent of the motors it repaired are premium efficiency. Most shops either do not work with premium efficiency motors, or these motors constitute less than 5 percent of their business. Slightly more than half the shops surveyed (53 percent) routinely document the rated efficiency of motors when they come into their shop.

Almost half the shops surveyed (45 percent) had no definition for premium efficiency or displayed no understanding at all of the factors that contribute to energy efficiency. An additional 41 percent displayed some knowledge of premium efficiency. These respondents could describe some of the key factors influencing energy efficiency (the importance of core losses, the existence of utility or NEMA standards). Fifteen percent of the respondents appeared to be quite knowledgeable. They could reference NEMA standards, understood efficiency was motor specific and understood efficiency depended on several factors for each motor. One reason for this is that the NEMA MG-1 revisions to standards are fairly recent.

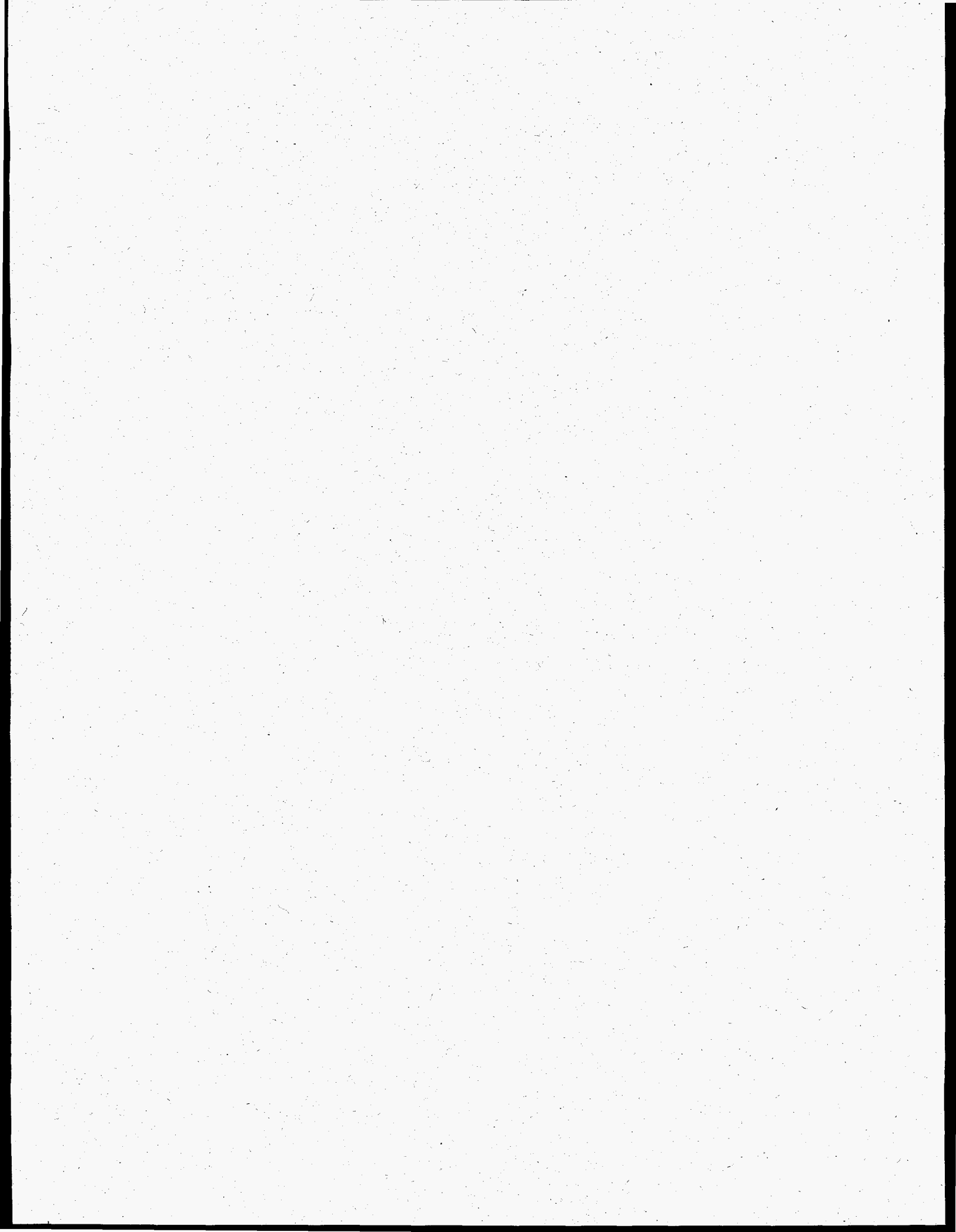
Part of the lack of understanding of energy efficiency definitions can be traced to the poor match between how shops describe efficiency and how they experience efficiency. Abstract and theoretical explanations of efficiency, such as the numerical definitions in NEMA 12-10 standards do not resonate well. Measurement of full load efficiency on which NEMA standards are based require a dynamometer set up for efficiency testing per the IEEE 112B protocols, which few shops have the capability to duplicate. Motor repair shops are very hands-on operations. When we asked shops to provide their definition of what premium efficiency is, most shops responded with pragmatic mechanical or procedural definitions. Thus it may be important to explain definitions of energy efficiency and the strategies required to maintain it during repair by describing mechanical features or procedural steps in addition to referencing standards.

Because most shops did not have experience with premium efficiency motors, readers should use caution in interpreting responses to questions about repair practices for premium efficiency motors. Many shops believed that maintaining original efficiency was more important for premium motors than standard motors.

Although there have been several attempts in the trade literature to dispel the misperception that premium efficiency motors are substantially more difficult to repair (e.g., Nailen 1993), the misperception remains. Twenty-eight percent of the shops said premium efficiency motors were more difficult to repair. Larger shops, which have more experience with premium efficient motors, were more likely to indicate that premium efficiency motors were harder to repair. However, less than one in five reported that any of the premium efficiency motors they repaired required procedures other than those they normally used. A number of those interviewed said they preferred older motors to energy efficient motors. Some of their concerns may have more to do with general design and material changes in newer motors as a class than any problem specifically with premium efficiency motors. Some newer aluminum frame motors, including both standard or premium efficiency models are harder to strip and have closer tolerances than their predecessors.

One-third of the shops stated that they encountered special problems rewinding premium efficiency motors. The three most frequently reported problems were difficulty winding because of closer tolerances and lack of space in slots; difficulty finding non-standard parts, especially wire and bearings; and controlling core losses during burn-out. The latter may reflect an attitude that it is less important to protect efficiency when repairing standard motors. In fact, core losses may be less of a problem for premium efficiency motors since premium efficiency motors typically have better core steel than standard motors, and new premium efficiency motors are manufactured with the same tolerances as standard efficiency motors. **These views indicate much misinformation about premium efficient motors lingers among motor repair shops.**

Shops which did have experience with premium efficiency motors reported that, on average, they rewound 92 percent of these motors with wire gauge and turns identical to original specifications. They also estimated that, on average, they replaced the fans on energy efficient motors with the same size fan 93 percent of the time. These may be overestimates given the difficulties shops reported keeping all wire sizes and parts in stock and obtaining or determining the appropriate winding patterns.



## Chapter 5

# Motor Repair/Rewind Costs

Motor shops, facing increased price competition, are sensitive to anything that adds to the cost of repairing motors. Many shops assume that quality motor repair will cost more. Cost increases are most likely in the following two areas: changes in general motor repair practices and increased cost of parts and labor.

## Overall Improvements in Motor Repair Practice

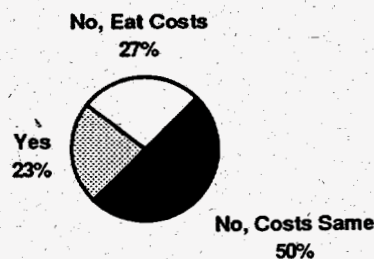
The first cost increase area is changes in general motor repair practice, such as improved quality control and expanded requirements for testing (e.g., core loss testing). Because procedures and recommended practices for efficient repairs have not been established, we did not attempt to estimate increased costs in this area. **Many shop owners were concerned that demands for maintaining efficiency during motor repair will push their costs up.** Their biggest concern was with increases in fixed costs for buying and operating sophisticated testing equipment. A second concern was for increased paper work and reporting if any repair standards were adopted. Smaller shops were more likely to voice concern than the larger shops. Some had heard rumors that EPACT would mandate more testing and paper work.

## Repairing Premium Efficiency Motors

Since premium efficiency motors are entering the repair market in growing numbers, we asked motor repair shops whether shops are incurring any increased costs when they repair these motors. Most repair shops have not had enough experience with premium efficiency motors to provide a definitive answer.

Half the shops reported that premium efficiency motors cost more to repair. Half of these shops reported that they passed on the costs to their customers. Thus, customers might be seeing higher prices on about one-quarter of the premium efficiency motors repaired.

Figure 30  
Do You Charge More For Premium Efficiency Motor Repairs?  
N=65





The 32 shops that said premium efficient motor repair cost more were asked to estimate the difference in costs for a standard and premium efficiency 100 hp, 4-pole TEFC motor. The survey defined standard efficiency as 92.6 percent and premium efficiency as 95.2 percent.

The median reported cost increase for the 32 shops was 10 percent. If those reporting no increased costs are included as zero, the median increase for all shops was 2 percent. Respondents were also asked whether the percentage change in costs was higher, lower, or the same for a larger motor (200 hp) and a smaller motor (10 hp). There was no clear pattern in the responses.

These findings are generally consistent with repair pricing data reported in *Vaughen's 1994 Complete Pricing Guide for Motor Repairs and New Motors*. Vaughen's uses a 10 percent price adder for repairing premium efficiency motors.

When asked to name the major source of increased costs, 81 percent of the shops said the biggest impact was from additional labor required to do more comprehensive testing and handle closer tolerances. Forty-one percent mentioned higher costs for parts. The parts-related cost mentioned most often was the cost of extra wire (copper), followed by higher quality bearings, and in rare cases special fans. Brithinee (1993) suggests that, as a rule of thumb, about 25 percent of the increased cost is for parts and about 75 percent is for labor. Some of this increase may be attributed to the lack of experience with premium efficiency motors. These costs may decline over time as premium efficiency motors penetrate the market. Case studies may be useful to document whether shops incur additional costs.

Shops with premium efficiency motor experience were more likely to report higher costs. Only 20 percent of the small shops indicated that premium efficiency motors cost more to repair, compared to 60 percent of the larger shops. These larger shops were also more likely to be knowledgeable about energy efficiency and have more exposure to premium efficiency motors.

In person interviews, with various experts representing motor repairers and manufacturers, stressed the need for closer rotor gap tolerance and tighter slot fill. These were viewed as the biggest difference between quality repair of energy efficient vs. standard motors.

**In summary, repairing premium efficiency motors may be around 10 percent more costly than repairing standard efficiency motors.** Contributors to increased costs include the difficulty in tracking down non-standard parts (especially bearings), labor and capital costs for additional testing, and working with closer tolerances and tighter slot fill during rewinding. However, some of these costs, such as additional testing should be incurred in any quality repair, whether of a standard or premium efficiency motor.

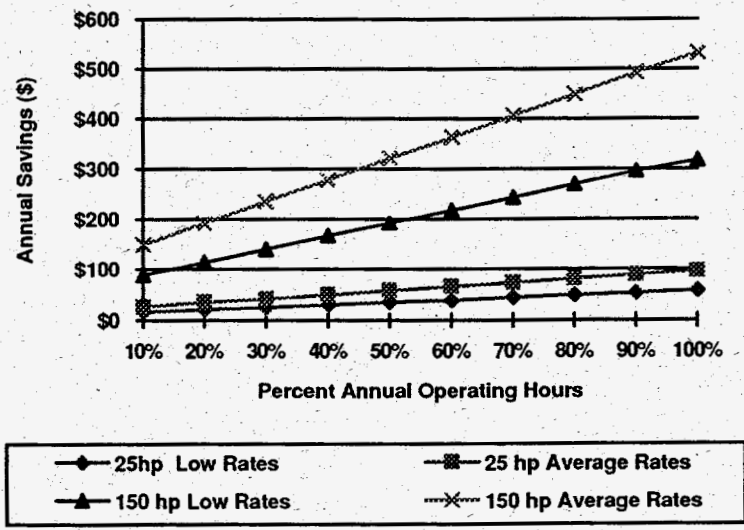
What does a 10 percent increase mean? A shop would spend an additional 1 to 1.5 hours in labor for the 100 hp motor used as the base case in the survey. This time is equivalent to an additional \$40 to \$60 based on average motor repair billing rates reported by Vaughen's (1994).

Given the tight profit margins and general pressure the industry is under, a 10 percent increase in cost, even on a temporary basis, is significant. Consequently, there may be value and/or need for some assistance in the form of rebates or a certification/grant program to support quality repair for both premium and standard efficiency motors.

# Energy Cost Savings Potential For Individual Motors

The savings associated with maintaining efficiency during the repair of an individual motor depends on the decrease in efficiency after repair, the number of hours a motor is operated, and the size of the motor. In addition, local utility rates affect the dollar savings the motor operator will realize. In Figure 31, estimated dollar savings from a 1 percent decrease in losses are reported for a 25 hp and a 150 hp motor over a range of annual operating hours. Dollar savings were calculated using utility rates from a low cost utility in the Pacific Northwest (\$.03/kWh and \$5.35/kW) and average national industrial and commercial rates (\$.05/kWh and \$9.00/kW) as reported by Andreas (1992).

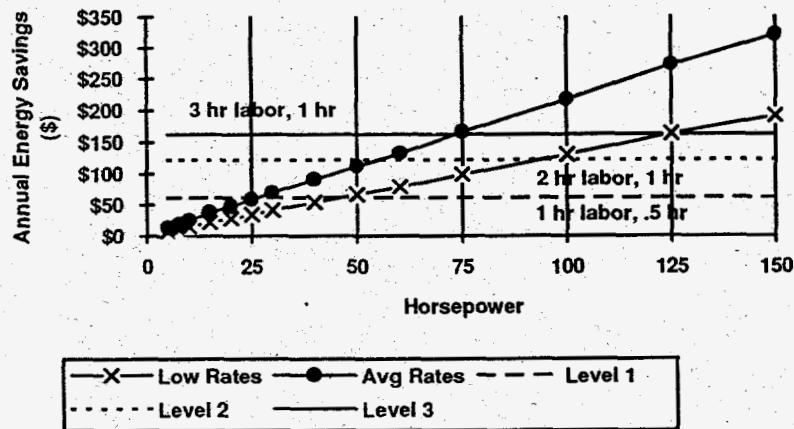
**Figure 31**  
**Annual Savings**  
**For a 25 hp and a 150 hp Motor**  
**By Annual Hours of Operation**



The energy savings from maintaining efficiency during repairs for a motor under 50 hp are small. Annual energy savings for a 25 hp motor operating one shift a week are valued under \$50. Assuming a 5 to 10 percent price premium for quality repair would yield a simple payback on energy savings of 2 to 3 years. Although a reasonable investment, the magnitude of energy savings is not likely by itself to generate much demand from end-users for quality repair unless they run many motors. Quality repair can be linked to greater motor reliability, longer motor lifetimes, reduced risk of premature motor failure, and reduced unexpected outages and forced downtime. These costs are much more significant to motor operators. Energy savings is only one reason for adopting repair practices that maintain motor energy efficiency.

Energy savings by themselves may also not be adequate to support large price premiums for the quality repair of small motors. To illustrate this point we have plotted estimated savings from a 1 percent decrease in efficiency for a motor running 50 percent of the time against estimates of national billing rates for motor repair labor provided by *Vaughen's Pricing Guide* (Figure 32). Average national billing rates (including profit) for electrical repair labor are approximately \$40 an hour. Machine time (for core loss testing, etc.) is typically billed at \$45/hour. Three levels of increased cost have been calculated that might represent the range of additional cost for energy efficient repair. Level one includes one additional hour of labor and 0.5 additional hours of machine time. Level two includes two additional hours of labor and one additional hour of machine time. Level three includes three hours of labor and one hour of machine time.

**Figure 32**  
**Annual Energy Savings of 1 Percent Avoided Efficiency Decrease**  
**By Horsepower**  
**Versus Increased Repair Cost**  
**(4380 Operating Hours/Yr)**



The survey suggested that incremental costs for maintaining energy efficiency are on the order of an hour or two per motor, and that increases in labor costs are dominated by fixed costs (e.g., testing set up), or they increase slowly with hp. Incremental costs for maintaining efficiency have not been precisely measured. Costs for specific energy efficiency measures could range from close to zero (having the right size wire on hand) to very costly (core loss testing). More information on the incremental costs of energy efficient repair is needed.

A third important consideration is that large utility investments in improving energy efficient repair in individual small shops may not be cost-effective. Forty percent of shops in the survey have ten or fewer employees. The median small shop repaired about 500 motors, of which 80 percent were under 40 hp. The annual savings potential at \$.05/kWh and \$9.00 kW is less than \$50,000. In comparison, a core loss tester costs between \$15,000 and \$30,000. This does not mean that small shops should not be included in any efficiency efforts. Instead, emphasis on developing low-cost strategies to improve repair practice in small shops is needed.

## Chapter 6

# Recent Utility and Government Incentives in Energy Efficient Repair

## Utility Programs

### Canadian Utilities

Most utility efforts to encourage energy efficient repair and rewind have been initiated in Canada. Nine Canadian utilities have formed a consortium to pursue joint research and education efforts. Canadian utilities involved in the Coordinated Utilities Approach include: Hydro Quebec, Ontario Hydro, British Columbia Hydro, Manitoba Hydro, Alberta Power, TransAlta, Nova Scotia Power, and New Brunswick Power. Two major initiatives are underway.

### New Canadian Electrical Association (CEA) Study of Motor Repair Techniques

The major focus of this study is to determine the impact of current repair practices on core losses (in a controlled environment). In addition, the study will look at the impact of current repair practices on other loss components and develop an acceptance test customers may use on new and repaired motors. The goal of the study is to develop a technical manual, from new and existing research, which will compliment quality standards such as EASA Q or ISO 9000. It is hoped that the core loss research will provide a definite answer to the burn-out over/core loss debate.

For more information contact: Dale Friesen, Manitoba Hydro, or Dan Dederer, Ontario Hydro.

### Canadian Quality Motor Service Program

Under the Coordinated Utilities Approach, the Canadian utilities are working together to develop a nationwide program to encourage rewind shops to adhere to rigorous quality assurance programs that support improved training for personnel, upgraded testing and repair equipment, and detailed documentation supporting repair work. The program is expected to be in effect by 1995.

The participating utilities felt that it was not necessary to develop a completely new set of standards when existing quality standards such as EASA Q and ISO 9000 were available to address issues such as calibration and documentation. Instead, the utilities chose to concentrate on the technical aspects of the motor repair and hope to develop a technical manual that deals with issues such as acceptance testing, repair procedures, training, etc. This technical manual will compliment existing quality standards and provide a framework for the Quality Motor Service Program.

For more information, contact any of the participating utilities.

### **Manitoba Hydro's Core-loss Tester Program:**

With only eight major repair shops in its service territory, Manitoba Hydro has been able to develop a close working relationship with each shop. Recognizing that repair shops in its service territory had limited access to test equipment, Manitoba Hydro offered to co-fund the purchase of core loss testers in exchange for a commitment from the shops to assist in the development of a Quality Motor Service Program. Under the agreement, participating shops are eligible for 50 percent funding towards the purchase price of a core loss tester up to a maximum of \$10,000 (CDN). In exchange for the funding, repair shops agree to perform core loss tests on all motors entering their shop and provide the information to Manitoba Hydro for analysis. In addition, each repair shop has agreed to assist in the research, testing, and evaluation necessary for the development of a Quality Motor Service Program in Manitoba.

Five of the eight shops have participated in Manitoba Hydro's program and have purchased core loss testers. Each shop has experienced considerable benefits from the implementation of core loss testing. The ease of use and simplicity of operation have encouraged repair shops to become much more active in testing cores. Core tests were conducted infrequently in the past because of the time-consuming nature of loop tests. An additional benefit of the program was an increased awareness by the repair shops of technical advancements in the repair industry and the need for quality control programs. As a result, several shops have sought and received ISO 9000 or equivalent CSA certification.

Manitoba Hydro recognizes the motor repair industry as an important ally in its effort to promote energy efficiency in the motors and drives arena. Manitoba Hydro believes that a strong and vital repair industry is necessary to provide assurance that today's efficiency gains (energy efficient motors) will be sustained for years to come.

For more information contact: Dale Friesen, Manitoba Hydro, (204) 474-4928.

### **United State Utilities**

A small number of utilities in the United States have developed DSM programs that are specifically targeted at motor repair and supporting the motor repair industry. Virginia Power has one of the most interesting programs.

#### **Virginia Power/North Carolina Power's Motor Rewind Customer Education Program:**

Virginia Power/North Carolina Power (VP) considered an early effort to develop and certify motor repair facilities. The primary reason for this decision was that EASA already has motor repair standards and is aggressively pursuing ISO 9000/EASA Q certification for its members. VP also felt that EASA has superior knowledge and experience with the repair of electric motors. The utility determined that a certification program by EASA would be more cost-effective, credible, and less controversial.

The first step for VP was to become an Associate Member of EASA. Presently, there are only two other electric utilities with this status. EASA membership provided access to literature, standards and conferences. VP promotes EASA standards at every opportunity, such as energy audits and customer meetings. In January 1994, VP conducted five motor seminars for over 300 commercial and industrial customers and distributed EASA standards and information to them. Identical motor seminars are scheduled for the fall of 1994.

VP's strategy is to educate the customer to base their decision whether to repair or replace existing motors on economics and individual motor circumstances. An important aspect of the recommended motor replacement/repair policy includes selecting a quality motor repair facility that meets EASA standards. VP does not recommend that motor users choose or avoid specific repair shops, however, several customers have changed shops based on EASA literature and standards.

For more information contact: Mark Webb, Virginia Power, (804) 771-3219.

#### **Free Motor Testing to Virginia Power Customers:**

VP's commercial and industrial customers have access to free and comprehensive motor testing (a value of \$1000 per motor) through the Industrial Electrotechnology Laboratory (IEL) in Raleigh, North Carolina. IEL members include most of the major electric utilities in Virginia and North Carolina.

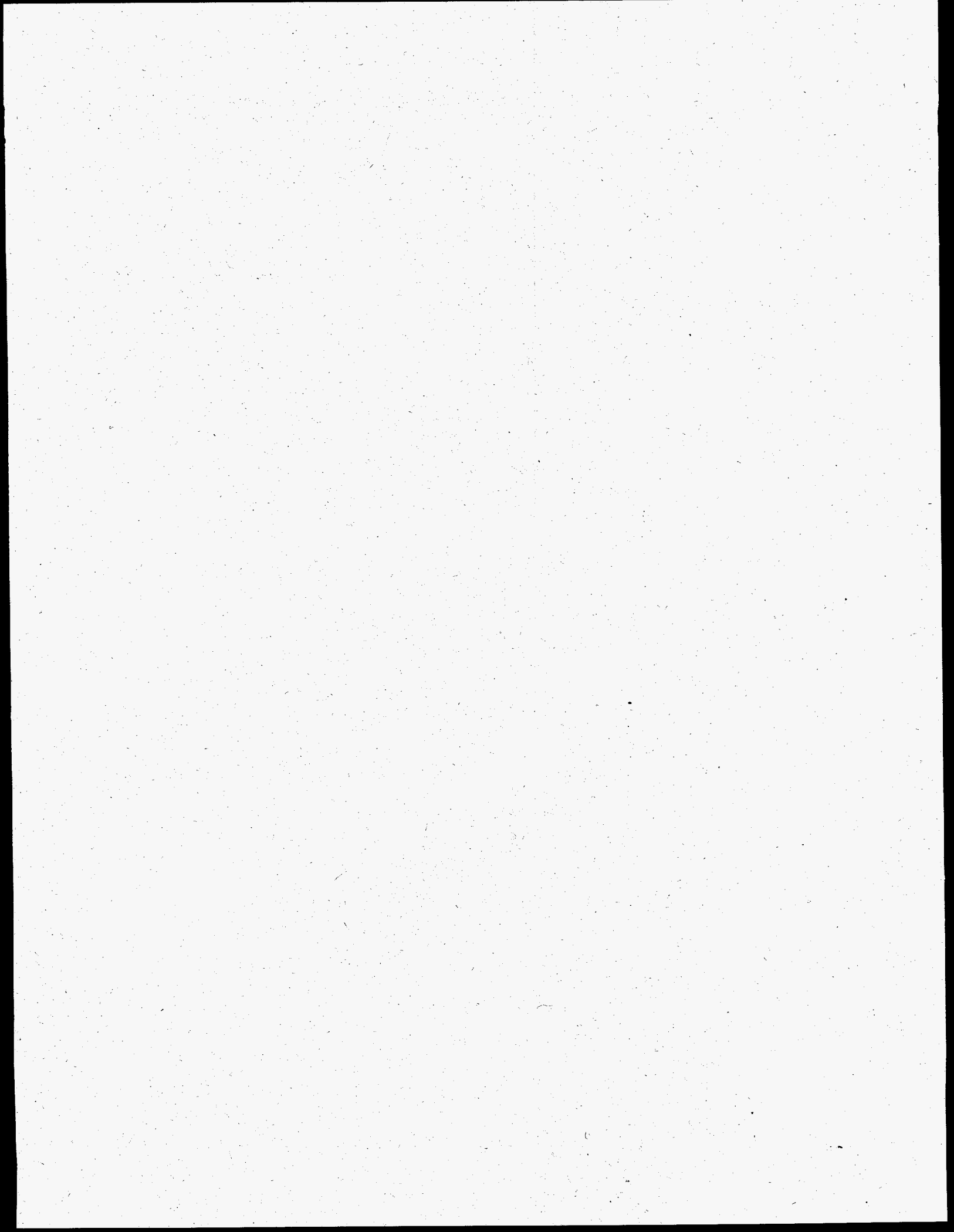
According to the program coordinator, the ability of rewind customers to have complete and independent laboratory data on the condition and efficiency of their motors places additional pressure on rewind shops to do a quality job.

For more information contact: Mark Webb, Virginia Power, (804) 771-3219.  
Ziba Kellum, IEL, (919) 515-6672.

#### **U.S. Government Initiatives**

The Energy Policy Act (EPACT) of 1992 does not reference the repair, rebuilding, and redesign of motors that have already been sold, and there is no discussion of repair standards, certification of repair shops, or methods in the Act. EPACT may have an indirect impact on motor repair because it sets efficiency standards for the manufacture of new motors. These standards may increase the differential in first costs and may make motor repair a more attractive alternative.

EPACT calls for the United States Department of Energy (USDOE) to promote higher efficiency of motors and drive systems through a five-year research program. This mandate has spawned the Motors Challenge program. The Motors Challenge is an Industry/Government collaborative dedicated to put "information on energy-efficient motor systems into the hands of the people who can use it." Motor repair issues will be addressed as part of this effort, since building new energy efficient motors is only a partial step towards national goals.



## Chapter 7

# Barriers to Energy Efficient Rewinds

We have identified ten major barriers to maintaining energy efficiency during motor repair and rewind.

- Many repair shops do not understand how to maintain energy efficiency during repair.
- Most motor repair customers do not recognize quality motor repair and seldom ask for it.
- Manufacturer's data on original motor specifications is often unavailable or not accessible.
- Some parts and wire sizes are not available locally.
- Some shops lack the tools and equipment for winding and winding redesign.
- All shops do not have the tools or practice to remove windings in a manner which does not damage motor cores.
- Shops do not routinely do many types of testing important for maintaining efficiency.
- Small shops face particular challenges in adjusting to an industry in transition.
- The industry lacks comprehensive data on the magnitude and sources of decreased efficiency after motor repair and the costs and effectiveness of remedies.
- There can be technical problems associated with tighter tolerances and slot fills.

## Many Shops Do Not Understand How to Maintain Energy Efficiency

Many shops do not have a thorough understanding of how to maintain energy efficiency during motor repair. In our research, we encountered several common misconceptions, many of them were also reported by Nailen (1993). Among them were:

- *Misconception: Energy efficient repair practice is only important in repairing premium efficiency motors.*

*Reality:* The opposite is the case. The largest decreases in efficiency after repair typically are found after repair of standard efficiency motors.

- *Misconception: Premium efficiency motors are significantly more costly and more technically difficult to repair than standard efficiency motors.*

*Reality:* Technically there are few major differences between repairing premium and standard efficiency motors. Cost of repairing premium efficiency motors is somewhat higher because of closer tolerances and problems with the availability of parts. However, some of the problems shops associate with premium efficiency motors, such as smaller slots and closer tolerances are not entirely limited to energy efficient motors. Also some shops tend to associate certain quality repair practices, which should be followed with all motors, only with energy efficient motors.



- *Misconception: Core losses from burn-out practices are the major source of decreased efficiency in motors after repair, and controlling burn-out is the only important loss prevention strategy.*

*Reality:* This misconception is partly a result of EASA's success in educating the repair community about core loss issues. More recent research suggests that bearing replacement, winding configuration, and wire size can be major contributors to efficiency losses.

- *Misconception: Premium efficiency motors do not save energy.*

*Reality:* If selected and sized appropriately for an application, a premium efficiency motor will use less energy than a similar sized standard motor. It is also true that potentially much greater savings can be realized through process and motor system redesign.

- *Misconception: Federal standards for energy efficient motor repair are in the works.*

*Reality:* No federal standards for energy efficiency motor repair are planned. The 1992 Energy Policy Act only requires that federal energy efficiency standards be developed for some common classes of new electric motors.

- *Misconception: Upgrading insulation improves efficiency.*

*Reality:* Upgrading insulation is a critical measure with regard to reliability, but its impacts on efficiency are minimal.

In addition, many shops had difficulty differentiating between standard and premium efficiency motors. Almost half the shops surveyed did not check incoming motors for efficiency levels. Generally larger shops had a better understanding of motor efficiency issues than smaller shops.

#### *Recommendations:*

- Continue efforts to provide solid technical data to shops through industry associations and utilities. Documents such as EASA's Technical Note 16, *Maintaining Motor Efficiency During Rebuilding* need to be regularly updated and broadly distributed.
- Complete and distribute practical guidebooks on maintaining energy efficiency through quality motor repair. In addition to the guidebook being prepared as a companion piece to this report, there may be opportunities to collaborate with the Canadian utilities, which are also developing a guidebook for quality motor repair.
- Provide training seminars on maintaining energy efficiency during motor repair in conjunction with key repair industry conferences.
- Improve the visibility of efficiency in shops - e.g., "Do's and Don'ts" posters.
- Link energy efficiency more effectively to motor reliability.

# Most Motor Repair Customers Do Not Recognize Quality Motor Repair And Seldom Ask For It

Motor repair customers are even less likely than motor shops to recognize a quality repair that maintains energy efficiency. There is little demand for energy efficient repair except from the largest, most sophisticated customers and from a very limited number of utilities. Shop owners report that many of their clients do not have the time or sophistication to identify quality in a motor rewind. Few customers provide detailed specifications. Customers need tools to identify:

- The elements of a quality repair.
- The challenges faced by repair shops and what they need from the customer to provide the best service.
- The value of paying for higher levels of service (and efficiency).
- How to get higher levels of service (and motors rewound without efficiency losses).

## *Recommendations*

- Establish a voluntary, industry-led repair shop certification program through which shops could earn certification by going through training, having key testing equipment and implementing existing quality assurance standards (ISO 9000 or EASA Q). Provide an easy to recognize certification label, such as "Energy Star Motor Repair Shop." To be most effective and sustainable, these types of certification must be industry run.
- Utilities can play an important role in educating motor users on how to identify good repair shops and on the benefits of higher levels of service and energy efficient repair. Virginia Power's motor user education program is a successful model.
- Provide point of sale fact sheets and other educational materials linking energy efficiency and reliability.

# Manufacturer's Data On Original Motor Specifications Is Often Unavailable Or Not Accessible

Shops reported that winding data was not readily available for 30 to 40 percent of the motors they repaired. Specifications for bearings, fans and lubricants are also difficult to obtain in a timely fashion. In some cases this information can be reverse engineered, but this is time consuming and can be inexact.

Data availability varies considerably by manufacturer. For example, Baldor and Toshiba have generally good reputations for providing this data. Some large American and foreign manufacturers are less responsive. Small off-shore and specialty motors pose particular problems. Some manufacturers consider this data to be proprietary and are reluctant to make it readily available. Others consider it a salable commodity and charge for it. An even bigger problem is the lack of a system with which to provide available data to all shops in a timely manner.

Manufacturers do not have a strong incentive to provide this data and to make their motors easier to repair. Manufacturers question the value of motor reparability. Although motor end-users expect larger motors to be repairable, new motor customers do not appear to stress ease of reparability (including availability and access to repair specifications) when purchasing motors.

### *Recommendations*

- Publicly recognize motor manufacturers that provide good access to manufacturing specifications to repair shops. Preferably, this should be done in settings where major motor purchasers are present.
- Develop a 1-800 or same-day service for manufacturer's data. Motor shops have a strong interest in having access to this type of service.
- Work with motor manufacturers to develop a computer database for motor winding data (Rewind Master). In addition to winding data, this database should be expanded to include core loss, grease, bearing, and fan specifications.
- Encourage motor manufacturers to release motor specifications and cooperate more effectively with the repair industry. Utilities and the federal government can play a role here. More customer education may also be needed on the importance of reparability for large motors and the factors that support reparability.
- Work with manufacturers to improve information provided in nameplate data. Two important pieces of information for maintaining efficiency levels that are not normally available on nameplates are winding resistance and no-load wattage.

## **Some Parts and Wire Sizes are Not Available Locally**

If the right bearings or the right diameter wire is not immediately available, shops will often use substitutes. Small and mid-size shops reported that it was difficult for them to keep complete stocks of all wire sizes (particularly metric and half-sizes) and bearing types (particularly specialty bearings) and to get access to parts and wire in a timely fashion. Costs for keeping a large inventory of seldom used wire sizes can be prohibitive, particularly if shops can not purchase them in small quantities.

Having the right parts available (or having access to them) may be the most effective strategy for maintaining efficiency during winding. The cost of improving access to most wire sizes, specialty bearings and other parts may be lower than some of the other strategies mentioned.

### *Recommendations*

- Educate shops on the importance of having the right parts and wire in the motor. This is best done through existing trade associations.
- Encourage motor manufacturers to stock replacements for custom bearings and to make them available quickly and without excessive markup.
- Develop a recommended wire and parts stocking list for the "well-equipped shop."
- Work with manufacturers and industry associations to develop a specialty wire and parts clearinghouse to locate and ship out hard to find parts.
- Consider encouraging individual smaller shops to form local purchasing cooperatives to improve local availability of hard-to-find parts and wire.
- In the long-term, the issues could be best dealt with by working with manufacturers to standardize key motor parts as is now being done in the European motor market. An initial feasibility assessment should be considered.

## Some Shops Lack the Tools and Equipment for Winding and Winding Redesign

Even with good winding data from manufacturers and the right wire in stock, shops change winding patterns and wire sizes. Several shops appeared not to be aware of the potential efficiency and reliability impacts of changing winding configurations. Their primary winding concerns are torque, durability and ease of winding. Shops generally do not have the equipment to test the impacts of alternative winding strategies or the analytical tools to properly redesign windings if the winding pattern is changed. A significant number of shops, particularly smaller shops, have limited winding equipment. Fifteen percent of the shops surveyed noted that they changed from concentric to lap windings because of equipment limitations.

### *Recommendations*

- Place greater emphasis in education efforts and technical notes on the importance of maintaining wire size and winding configuration. More information on the impacts and trade-offs of changing winding specifications needs to get on the shop floor.
- Include minimum winding equipment standards in any voluntary certification efforts and quality assurance standards.

## Removing Windings in a Manner Which does not Damage Motor Cores

Removing windings in a manner that does not increase core losses remains a challenge. Motors that have been previously rewound pose even more challenges because of the numerous dips, bakes, and epoxies used. Stripping motors chemically is not always effective, and many shops are concerned about chemical disposal problems and exposure to toxic materials. As a result, most windings are removed by burning them out in ovens. Burning out windings at temperatures over 650° F can significantly increase core losses by damaging the core laminations. Burning out windings at under 650° F often takes too long. Almost 40 percent of the shops surveyed typically used temperatures of 750° F or more during burn-out. This problem may be less severe for new motors with cores made with c-5 steel, which is less subject to problems with overheating.

Forty percent of the shops in the survey did not have water suppression systems, most did not frequently calibrate temperature controls, and few shops placed temperature sensors in the motor cores.

### *Recommendations*

- In the long-term, the best strategy may be to develop dips and varnishes that are easier to strip or burn-out during rewind. Chemical companies need to work with motor repair shops and manufacturers to develop more effective processes and products. Federal research support could accelerate progress here.
- In the near term, more research on low cost strategies for improving temperature control and distribution during burn-out would be useful. Field research on the level of impact from over and under heating in uncalibrated ovens may be instructive.

- Continue ongoing efforts to educate repair shops on the importance of controlling burn-out temperatures and the proper use of temperature control strategies (core sensors and water suppression systems).
- Utilities could provide financial assistance to shops to encourage purchase of burn-out ovens with better controls.
- Include standards for burn-out equipment and calibration intervals in any voluntary certification programs.
- Improve the availability and accessibility of manufacturers' data on allowable core burn-out temperatures and acceptable core loss test results.

## Insufficient Testing During Motor Repair

Proper testing is essential to diagnose repair problems and to ensure motor efficiency has not been adversely impacted during repair. All shops should routinely conduct tests for insulation integrity, winding resistance, vibration, rotor balance, and core loss during all repairs, particularly for larger motors. Of these tests, only insulation testing is done routinely. Among the reasons for this are:

- Lack of testing equipment. Only 40 percent of the shops have core loss testers, and 60 percent have vibration testers. Less than 20 percent of the small shops have this equipment. Cost is a major barrier for shops that want to acquire a core loss tester.
- Lack of information on the role and value of testing. Some shops view winding resistance, vibration, and core loss tests primarily as diagnostic tools to be used only if there are obvious performance problems.
- Cost of testing relative to repair costs for small motors. Comprehensive testing (especially core loss testing) may not be cost-effective for smaller hp motors.

Other problems were the lack of manufacturer's data to benchmark tests and the absence of easy-to-use test protocols and reference values.

### *Recommendations*

- Utilities can provide rebates to repair shops for expensive testing equipment (particularly core loss testers). The Manitoba Hydro program is a potential model. This approach may not be cost-effective for smaller shops.
- Provide basic information on the importance of routine testing to motor repair shops. Develop shop-floor-oriented, hands-on, how-to guidebooks for testing during motor repair. This may be another area for collaboration with Canadian utilities
- Develop both best practice testing manuals and alternative lower cost approaches for smaller shops to use.
- Work with manufacturers to improve the availability of original test specifications for motors. The two most important pieces of data that a motor manufacturer can provide for the benefit of maintaining motor efficiency are winding resistance and no-load wattage. Manufacturers could provide this information on the nameplate, preferably for the high voltage connection.

# Working with Small Shops in an Industry in Transition

Any effort to work with the motor repair industry must acknowledge that the industry is under pressure from the availability of low cost new motors, declining profit margins, increased labor costs, and the general trend away from manufacturing in the U.S. economy. Shops will resist approaches that rely heavily on increased government regulations and mandates. Additional mandates could also contribute to weakening the industry further.

Numerically the industry is dominated by small shops that have low repair volumes, work on smaller hp motors, and have small staffs. These shops are the least likely to have all the best equipment or training for quality repair and the least able to afford it. The small energy savings potential in these shops may not justify significant utility or federal investment. It is not cost effective to subsidize the purchase of a \$15,000 to \$30,000 core loss tester, other test equipment, or sophisticated burn-out equipment for a shop that only handles 250 small hp motors a year. Requirements for more testing equipment or maintaining larger stocks of spare parts could contribute to driving smaller shops out of the repair business.

## *Recommendations*

- Identify low cost strategies, such as tip sheets, to improve repair practice at small shops. Where possible provide lower cost options to more expensive practices. For example, less expensive no-load testing can be substituted for core loss testing to diagnose major core loss problems when a motor is operable. EASA Tech Note 17 on core loss testing can be used in lieu of purchasing a core loss tester.
- Support quality assurance programs in the repair industry and link energy efficient repair to quality assurance. Motors repaired in shops with strong quality assurance programs are much less likely to be repaired in a manner that increases efficiency losses. Quality assurance programs are a key strategy for keeping the repair industry competitive and healthy. Utilities and federal agencies could take several actions to encourage quality assurance programs, including awards for outstanding quality assurance efforts, support for training, and quality assurance certification programs.

## **Lack of Data on Efficiency Decreases After Repair and the Costs and Effectiveness of Remedies**

Very little comprehensive research has been done to associate the magnitude of decreases in efficiency with specific motor repair practices and to understand how these practices interact. We were able to identify only four studies that attempted to quantify increases in losses after motor repair. These studies had very small sample sizes and were restricted to small hp motors. There have been no comprehensive studies done on motors over 100 hp, with the possible exception of a General Electric study done in 1984 (see McGovern 1984). Several areas in which further investigation is needed are:

- Are the percentage increases in losses for large motors of the same magnitude as for smaller motors. Are problem practices as common in the repair of larger motors?
- What are the efficiency and performance implications of specific problem repair practices? Priority areas of investigation are bearing change outs, changing winding configurations (especially concentric to lap), altering wire sizes, and core loss damage.

- How effective are alternative strategies in reducing core loss during burnout (oven calibration, water suppression systems, and alternative burn-out regimes) and in diagnosing core losses? Some work in this area is underway at EASA and by the Canadian utilities.
- How much do specific energy efficient repair practices contribute to motor reliability and performance? For example, does using smaller wire size significantly impact repair life?
- What are the incremental costs for specific energy efficient motor repair practices?

Cost is one of the major reasons there has not been much research on repair practices, particularly for large motors. A new 150 hp TEFC AC motor costs between \$6,000-\$10,000. The cost of a used motor is typically 70 percent of the cost of a new motor. Rewind and/or repair costs are likely to be in the \$3000-\$5000 range. The costs per motor repair studied are already in the \$10,000 to \$15,000 range before any testing or analysis is done.

*Recommendations:*

- Establish a bench testing program where a limited number of motors, over a wide range of hp, are tested with a variety of alternate wire sizes and configurations and repair problems.
- Work cooperatively with a sample of repair shops that will agree to repair motors using energy efficiency repair specifications and record related costs (referenced to current industry practices) during the repair process. Consider providing incentives to cover the additional costs for tracking results and "extra" labor and materials. WSEO has had considerable success with this methodology when researching the incremental cost and thermal performance of building houses to model conservation standards.
- Continue to assess the effectiveness of alternative strategies for limiting core damage during burn-out. Coordination with the Canadian Utility Consortium may allow our efforts in this area to complement one another. A related issue is burn-out oven performance. Industry leaders have told us that oven performance varies considerably and internal temperatures are rarely uniform. Moreover, local oxidation (i.e., burning) can raise the temperature of parts of the core well above oven temperature. This issue may need to be explored more thoroughly.
- Initiate a long-term study comparing failure rates of motors repaired in shops whose staff have received training in energy efficiency repair with a control group of shops with untrained staff. Both large and small shops should be included in the study. The results of the study would help indicate the benefits of training and the relative impact of this training in large versus small shops.

### **Technical Problems Associated with Tighter Tolerances and Slot Fills**

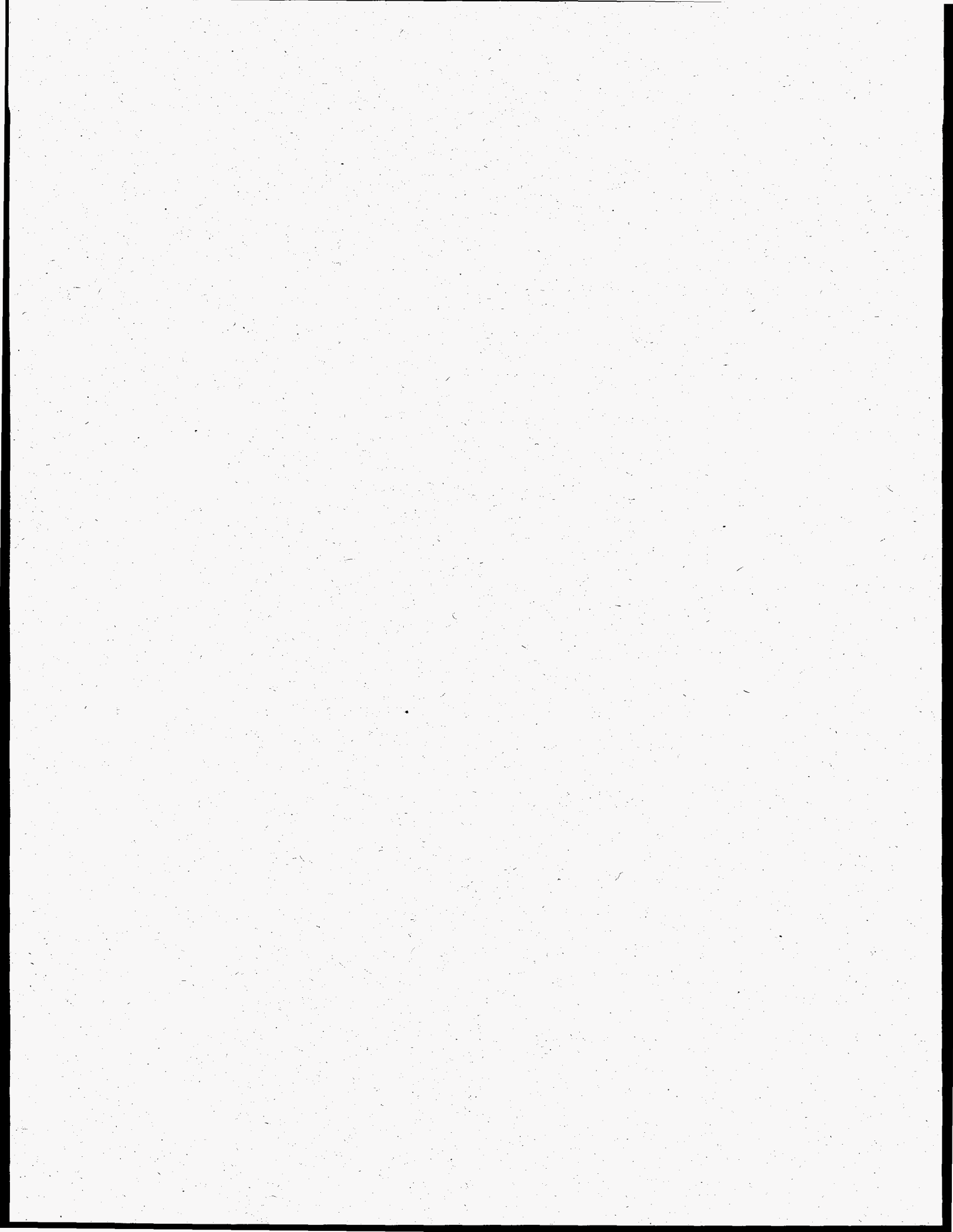
Newer motors often have tighter tolerances. The air gap between rotor and stator is a place where this can cause problems. Air gaps tend to be smaller in energy efficient motors. This requires greater care in bearing work and REASSEMBLY to ensure close concentricity between shaft and rotor. Otherwise, increased vibration and reduced efficiency can occur.

Manufacturers often use machine winding techniques to place random wound coils in the core. This often results in a tighter slot fill. Machine winding techniques involve a set up for high volume production of a single design and are not possible for repair shops. It is difficult to achieve the tight slot fills by manual coil insertion methods.

### *Recommendations*

- Place greater emphasis in education efforts on the importance of maintaining concentricity of rotor and stator. This can generally be achieved with greater care, without special equipment.
- Encourage manufacturers to improve the reparability of motors. Some manufacturing methods producing tighter fits may be relaxed in favor of other techniques for maintaining efficiency.
- Utilities can play a role in educating motor users to seek and select motors which are known for good reparability.





# REFERENCES

- Andreas, John C. "Automation." April 1974. pp 82 and 85.
- Andreas, John C. "Energy-Efficient Electric Motors: Selection and Application." 2nd ed. New York, New York: Marcel Dekker, Inc., 1992.
- Brithinee, Wallace. Electrical Apparatus Service Association, Personal Conversation, November, 1993.
- Brutlag and Associates. *1993 Member Needs Assessment: Final Report*, Chicago, Illinois: Electrical Apparatus Service Association, Inc., 1993.
- Colby, Roy S., and Denise L. Flora. *Measured Efficiency of High Efficiency and Standard Induction Motors*, Raleigh, North Carolina: North Carolina State University, Department of Electrical and Computer Engineering (IEL), 1990.
- EASA 1992, *EASA Standards for the Repair of Electrical Apparatus*, St. Louis, Missouri: Electrical Apparatus Service Association, Inc., February 1992.
- EASA 1992 "Tech Note No. 16: Guidelines for Maintaining Motor Efficiency During Rebuilding." St. Louis, Missouri: Electrical Apparatus Service Association, Inc., May 1992.
- EASA 1993, *EASA-Q: Quality Management System for Motor Repair*, St. Louis, Missouri: Electrical Apparatus Service Association, Inc., 1993.
- EPRI 1992, *Electric Motors: Markets, Trends, and Application*, Electric Power Research Institute, June 1992. TR-100423.
- EPRI 1993, *Electric Motor Systems Sourcebook*, ed. Electric Power Research Institute, 1993. RP 3087-21.
- Friesen, Dale. Manitoba Hydro, Phone Conversation, March, 1994.
- Fryer, Lynn R., and Corey Stone. "Establishing Baseline Practices in the Industrial and Commercial Motor Market: Findings from the New England Motor Baseline Study." *Proceedings: 6th National Demand-Side Management Conference*, pp. 139-147. Palo Alto, California: Electric Power Research Institute, March 1993. TR- 102021.
- ISO 9000: Quality Management and Quality Assurance Standards: Guidelines for Selection and Use*, 1st ed. Geneva, Switzerland: International Organization for Standardization, 1987.
- McCoy, Gilbert A., Todd Litman, and Johnny G. Douglass. *Energy-Efficient Electric Motor Selection Handbook*, Olympia, Washington: Washington State Energy Office, February 1992.
- McGovern, William U. "High-Efficiency Motors for Upgrading Plant Performance." *Electric Forum* 10, No. 2 (1984): pp. 14-18.
- Mehta, Vino. "Future for the Motor Rewind Industry: A Survival Strategy--Part One." *EASA Currents* 28, No. 2 (February 1994): pp. 4-6.
- Nailen, Richard L. "A User's View of Motor Repair Standards and Specifications." *IEEE Transactions on Industry Applications*, Vol. 24, No. 6, November/December 1988, pp. 1131-1137.

Nailen, Richard L. "Fairyland revisited: More myths about energy efficient motors." *Electrical Apparatus* Vol. 46, No. 5, May 1993, pp. 26-31.

Nailen, Richard L. *Managing Motors: The Complete Book of Electric Motor Application and Maintenance*. Chicago, Illinois: Barks Publications, Inc. 1991.

Ontario Hydro 1991, Dederer, D. H. "Rewound Motor Efficiency." *Ontario Hydro Technology Profile*, November 1991.

Ontario Hydro 1992, Ontario Hydro, Energy Management and Corporate Relations Branch, Technical Services and Development. *The Effect of Repeated Rewinding on the Performance of Electric Motors*, Toronto, Ontario, 15 June 1992. TSDD-92-035.

Resource Dynamics Corporation. *Electric Motors: Markets, Trends, and Applications*, Palo Alto, California: Electric Power Research Institute, June 1992. EPRI TR-100423.

Seton, Johnson and Odell, Inc, Consulting Engineers. *Energy Efficiency and Motor Repair Practices in the Pacific Northwest*, Portland, Oregon: Prepared for the Office of Conservation Bonneville Power Administration Under Contract No. DE-AT79- 87BP34486, November 1987.

U.S. Department of Energy. *Classification and Evaluation of Electric Motors and Pumps*, : Assistant Secretary for Conservation and Solar Energy, Office of Industrial Programs, February 1980. DOE/CS-0147.

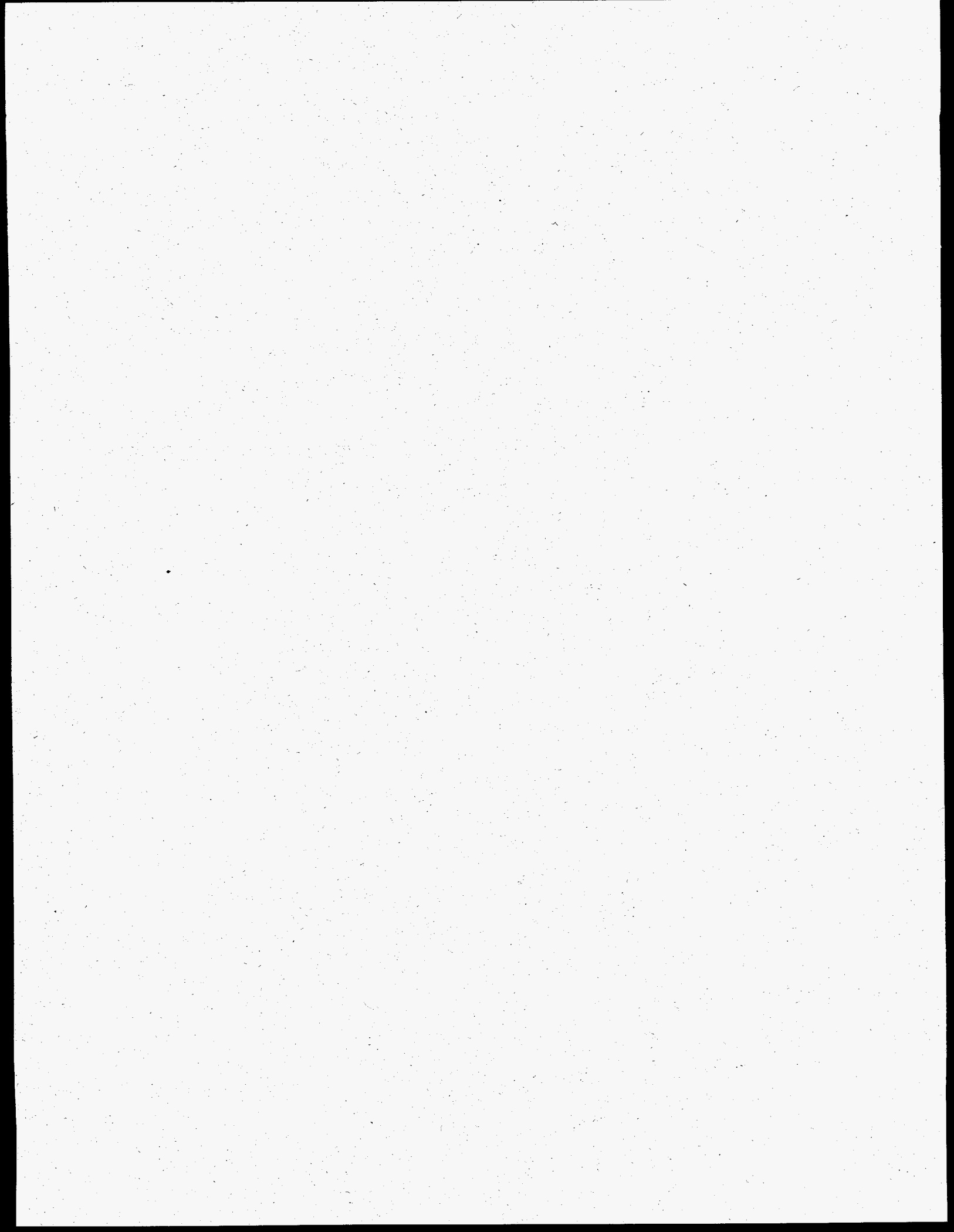
Vaughen's Price Publishing Company, Inc. *Vaughen's Complete Price Guide for Motor Repairs and New Motors*, Pittsburgh, PA. January 1994.

Washington State Energy Office, MotorMaster [computer software], Version 2.1, January 1994, by Gilbert McCoy and Todd Litman, Computer: IBM-Type PC.

Zeller, Markus. *Rewound High-Efficiency Motor Performance*, Vancouver, British Columbia, Canada: B.C. Hydro in association with Powertech Labs, Inc., 28 August 1992.

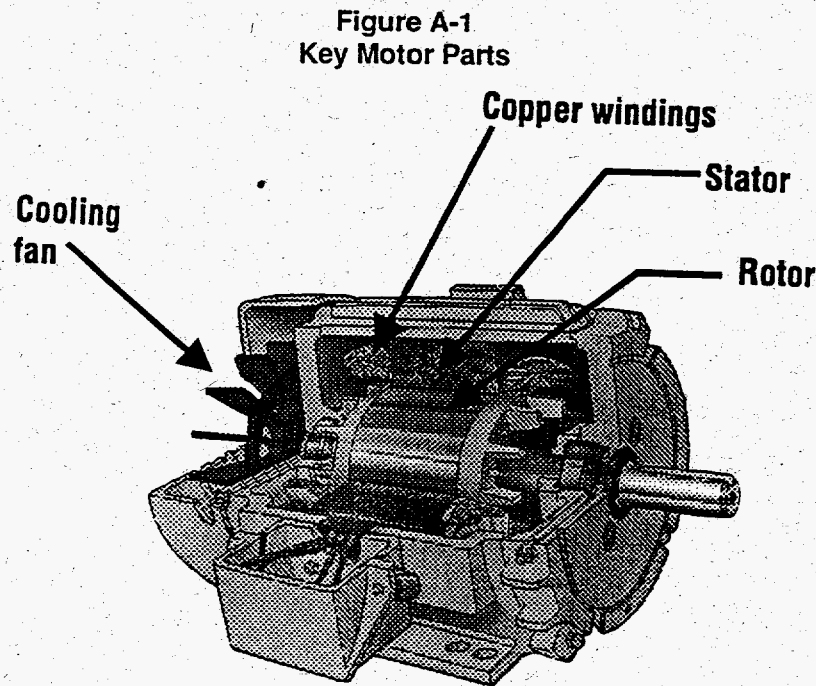
# **Appendix A**

## **Motors And Motor Efficiency**



# Motors and Motor Efficiency

An AC induction motor consists of two parts, a stationary part (the stator) and rotating section (the rotor) both of which can sustain a varying electromagnetic field. The body of the stator (or stator core) is wrapped with electric wires (or windings) that fit in slots in the body of the stator. The rotor is not connected to a source of electricity. (Wound rotor motors have leads coming out to a switchable resistor bank.) The rotor is connected to the motor frame by bearings that allow the rotor to turn while the stator is held in place. The major parts of a motor are identified in Figure A-1.



Motor manufacturers rate the technical lifetime of a motor between 15 and 30 years. A motor's life is significantly affected by the care it receives and the conditions in which it operates. There is little available data on motor lifetimes in the field. Large horse power motors typically last longer than smaller motors, as illustrated in Table A-1. This data was developed in 1980. The results of a similar study done today might show different results because of subsequent changes in motor technology.

**Table A-1  
Average Electric Motor Life**

hp Range	Average Life (Years)	Life Range (Years)
1-5	17.1	13-19
5.1 to 20	19.4	16-20
21 to 50	21.8	18-26
51 to 125	28.5	24-33
Greater than 125	29.3	25-38

Source: U.S. Department of Energy, 1980

Motors are likely to be repaired or rewound one or more times to extend their life times in the event of failure. Andreas (1974) summarized major causes of failure in a survey of 4000 motor failures in a large shop.

Table A-2  
**Motor Failure Survey Results from Large Motor Repair Shop**

Cause of Failure	Total Failures (%)
Overload (overheating)	25
Normal Insulation Deterioration (Old Age)	5
Single phasing	10
Bearing failures	12
Contamination (moisture, grease, chemical, dust)	43
Miscellaneous/2 percent Unknown	5

Source: Andreas (1974)

For motors over 50 hp, it is considerably less costly to rewind and/or repair motors and place them back in service rather than purchase a replacement, if the failure is not catastrophic. It is generally more cost-effective to replace motors under 10 hp, and therefore, they are rarely repaired unless they are special. The decision to repair versus replace failed motors between 10 and 50 hp is made on a case-by-case basis and may depend on the magnitude of needed repairs, replacement costs, and energy savings from upgrading from a standard efficiency to premium efficiency motors. Our focus in this study is on repaired and/or rewound motors between 5 and 500 horsepower.

### **Motor Losses and Efficiency**

A motor's function is to efficiently convert electrical energy to mechanical energy to perform useful work. The only way to improve motor efficiency is to reduce motor losses. Motor efficiency losses can be reduced in new motors through choices in design, construction, and materials. Improper motor rewind or repair can increase motor losses beyond original design levels and degrade motor efficiency. There are five major types of motor losses:

1. **Core loss** occurs because of the changing magnetic fields in the rotor and stator iron. Core loss is caused by hysteresis and eddy currents in the iron. During motor repair, core losses can increase if the core iron or the insulation between core laminations is damaged. This damage can be caused by overheating during burnout or by mishandling during repair.
2. **Windage and friction losses** occur because of friction in the bearings and air resistance against the rotating fan and ventilation air paths. These losses can increase during repair if bearing types or quality or grease types are changed. Substitution of an oversize fan can also increase losses.
3. **Stator losses** appear as heating because of current flow ( $I$ ) through the resistance ( $R$ ) of the stator winding. Hence, this type of loss is referred to as  $I^2R$  loss. Increases in stator  $I^2R$  losses result from changes in wire size in the stator windings, altering the winding pattern, and changes in the size and concentricity of the air gap between stator and rotor.

4. **Rotor losses** are  $I^2R$  losses that result from heating in the rotor cage or winding. Increased rotor losses will persist after motor repair if loose or cracked conductor bars are not detected and repaired, or if the air gap symmetry between rotor and stator is degraded because of damage to end shields or bent motor shafts.
5. **Stray Load Losses** include all efficiency losses that are not accounted for by the previous four categories. Stray load losses are primarily the result of leakage fluxes induced by load currents. Sources of increased stray load loss include damage to rotor laminations, change in the winding design, or changes in the air gap size or concentricity. These losses are difficult to measure and usually vary considerably more than other types of losses.

Motor losses vary by horsepower and load. Windage and friction losses increase with horsepower. Stator, rotor, and stray load losses increase with motor load. Core, windage, and friction losses are fixed with respect to load. They occur whenever the motor is energized and remain constant for a given voltage or speed. Percentage contributions of the five loss categories to total load are summarized in Table A-3.

**Table A-3  
Contribution of Motor Losses to Total Motor Loss**

Loss Category	Contribution to Total Loss (%)	Increases with Load
Core	15 - 25	No
Windage and Friction	5 - 15	No
Stator $I^2R$	25 - 40	Yes
Rotor $I^2R$	15 - 25	Yes
Stray Load	10 - 20	Yes

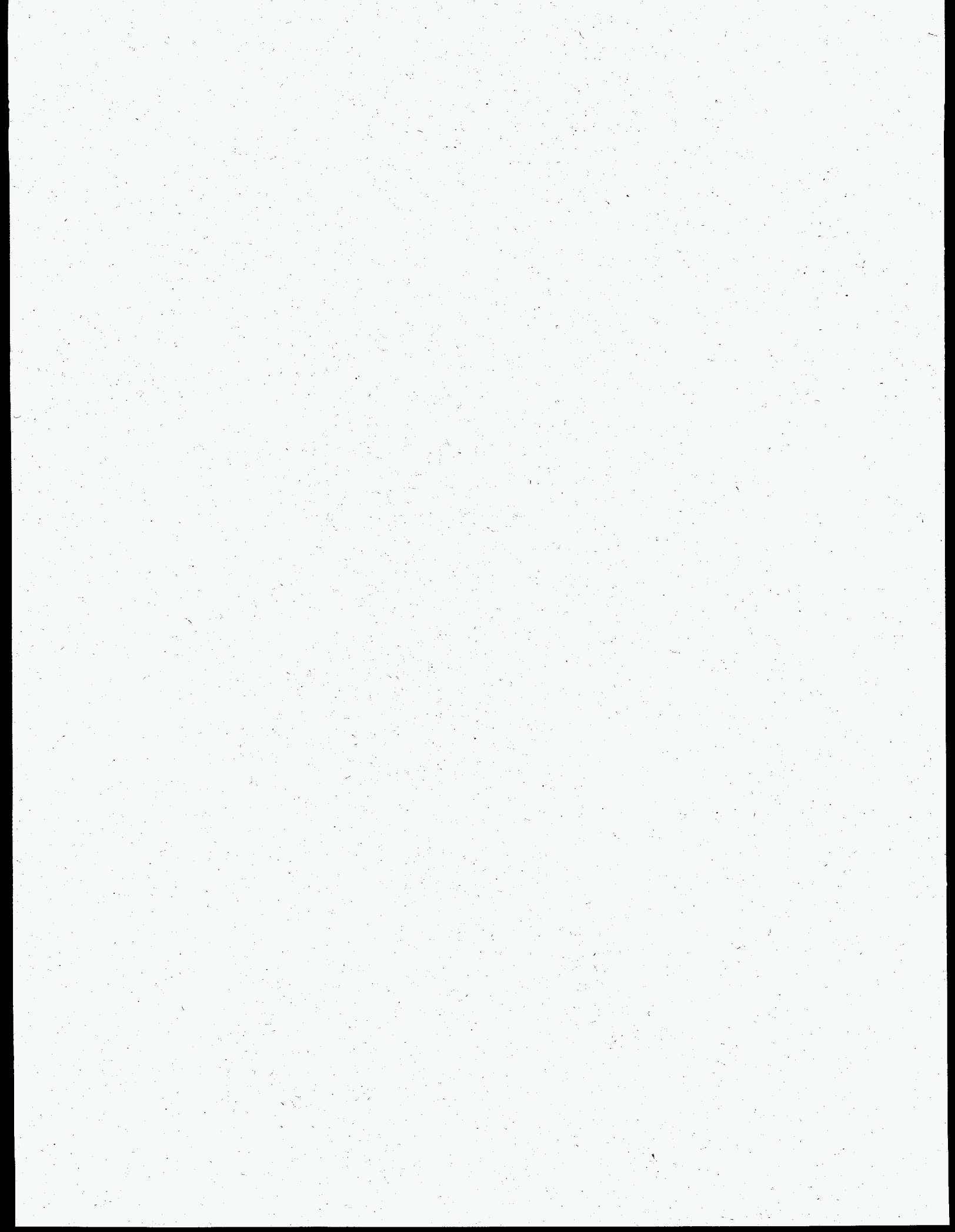
Source: McCoy, et al. (1992)





# **Appendix B**

## **Survey Methodology and Motor Repair Shop Questionnaire**



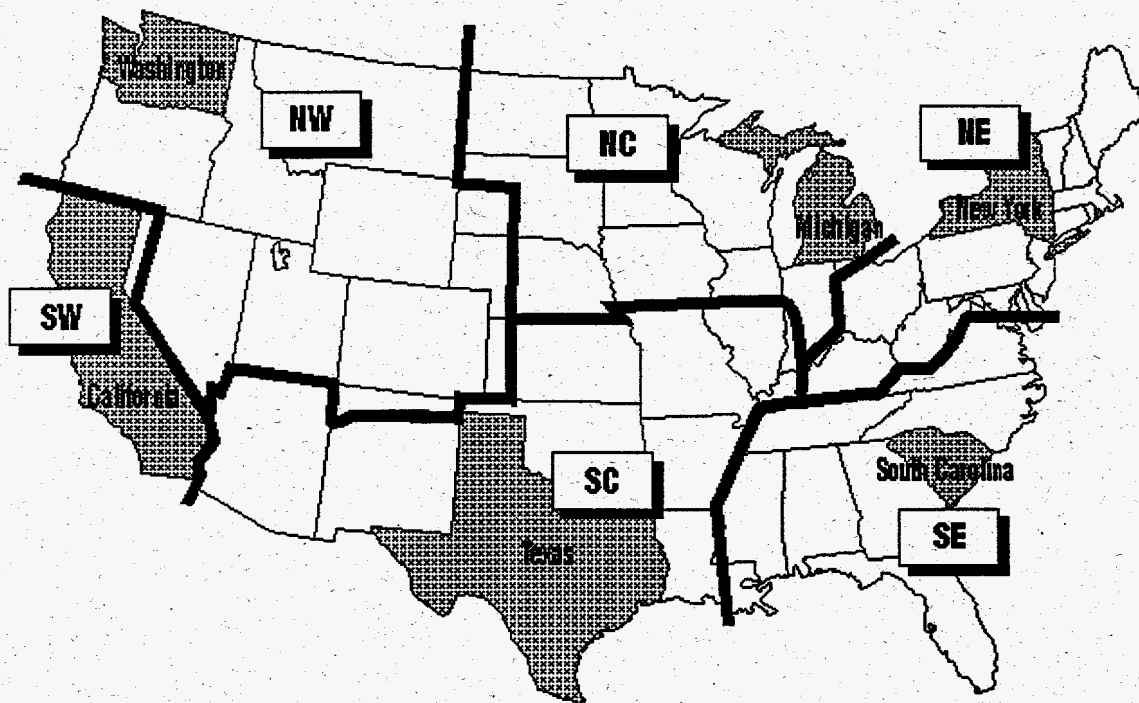
# Survey Methodology

The motor repair shops included in the survey were randomly selected within three sample strata to ensure the sample was reasonably representative: membership in the Electrical Apparatus Service Association (EASA), number of employees, and geographic region.

*EASA and Non-EASA Member Shops:* The Electrical Apparatus Service Association (EASA) is the largest trade association representing repair shops. Approximately half the motor repair shops in the United States are EASA members. EASA shops were sampled out of the EASA membership directory. Non-EASA shops were sampled from combined Yellow Pages listings under motor repairs for selected states. Yellow Pages listings were cross checked against the EASA directory. The remaining shops were contacted by phone to screen out shops that did not repair electric motors, repaired only fractional horsepower motors, or were no longer in business. Non-EASA shops were under sampled, since they are more likely to be smaller, low-volume shops.

*Region:* We also stratified the sample proportionately by six geographic regions. The regions we developed are combinations of the regions EASA uses to subdivide its membership. EASA shops included in the sample were drawn from states throughout each of the six regions. We developed the Non-EASA sample by selecting motor repair shops from Yellow Pages listings for a single state in each of the six sampling regions. The regions for the EASA sample and the states for the Non-EASA sample are identified in Figure B-1.

Figure B-1  
Regions and States Used For Drawing  
EASA and Non-EASA Samples



*Size:* Finally, we stratified the sample by total number of employees reported. We used the size categories provided by the *Yellow Pages* listing service (1-9 employees, 10-49, and 50 or more). Large and medium shops were over sampled since they account for a disproportionately large share of the total motors repaired.

Table B-1  
**Sample Disposition**

	N=	Percent
<b>EASA Membership</b>		
Yes	43	66%
No	22	34%
<b>Number Employees</b>		
Under 10	30	46%
10-49	24	37%
50 or more	11	17%
<b>Region - State</b>		
Northeast/New York	12	18%
Southeast/South Carolina	18	28%
North Central/Michigan	10	15%
South Central/Texas	13	20%
Northwest/Washington	8	12%
Southwest/California	4	6%

We worked closely with EASA in developing the EASA sample and the survey instrument. EASA also sent out a letter to its membership announcing the study and urging participation.

With the assistance of SBW, Inc. and Dethman and Associates, a comprehensive telephone survey was designed and administered in May and June of 1993. We have included a copy of the survey in Appendix B. Because of the complexity of the survey, respondents were contacted prior to the interview to schedule an interview time. They were then faxed an outline of key questions. In some cases, multiple call backs were required to complete the interview, or the survey was faxed to the shops and mailed back to SBW. SBW/Dethman and Associates completed sixty-one of the targeted sixty-five motor repair shop surveys. This was supplemented by four surveys completed during the Washington State Energy Office (WSEO) on-site visits.

Overall, the sample is a reasonable representation of the breadth and diversity of the motor repair industry in the United States. However, some segments of the motor repair market were not well represented. Non-EASA shops were under represented in the sample and were drawn from a more limited geographic sample frame than EASA shops. Large repair shops affiliated with motor manufacturers were also not well represented.

The sample was designed around the number of repair shops and not the volume of motors repaired. We did not attempt to weight responses by the horsepower volume of repair. Therefore percentage responses reported for all shops in the survey should not be directly translated to impact on the motor population. For example, forty percent of the shops surveyed reported they had a core loss tester. This does not mean that forty percent of the motors repaired are repaired in shops having a core loss tester. Because this issue and the small overall sample size, results should be interpreted as indicative of motor repair shop practices and not definitive.

# WSEO Motor Rewind Screening Survey

Hello, my name is \_\_\_\_\_, with SBW in Seattle, Washington. May I speak to [Name].

I'm calling to ask you to participate in an important national study of how to best promote higher efficiency in motor repairs. It's sponsored by the U.S. Department of Energy, the Electric Power Research Institute, and the Bonneville Power Administration. Your company is one of 75 shops across the country who will be asked to represent the electric motor repair industry.

Could I ask you a few preliminary questions?

A. Does your shop repair electric motors used in industrial and commercial applications? [Confirm that the shop works on electric motors used in commercial buildings and facilities or industrial processes. If not, thank and politely terminate.]

1 Yes ----> [Continue to Question B]

2 No ----> What types of motors does your shop repair?

---

---

B. Does your shop repair motors between 5 and 500 hp?

1 Yes ----> [Continue to Question C]

2 No ----> [Thank and politely terminate]

C. Are you the person in this shop to answer questions about electric motor repair, motor testing, and about issues related to energy efficiency in motor repair?

1 Yes ----> [Continue to Question D]

2 No ----> Who would be the best person to talk with

Name \_\_\_\_\_

Title \_\_\_\_\_ Phone (if different) \_\_\_\_\_

D. And how would you describe your major job responsibilities?

---

E. (Well, you're definitely the right kind of shop for this survey! We really would like to get your opinions on the topics I mentioned.) (HOWEVER) The rest of this survey will probably take about 45 minutes. Would this be a good time to talk, or should we set up another time? [Write down arrangements below.]

Date \_\_\_\_\_ Time \_\_\_\_\_

F. I'd like to fax you a few of the survey questions ahead of time. This will give you some extra time to track down the information you'll need to answer them. What is your fax number?

[If you get it] Let me verify your fax number?

---

Thank you. I'll get the fax off today and I'll talk to you on [date] at [time].

ID Number \_\_\_\_\_

**Motor Repair Shop Questionnaire  
Washington State Energy Office  
TELEPHONE SURVEY VERSION 5/12/93**

Shop \_\_\_\_\_  
Contact Person \_\_\_\_\_  
Title \_\_\_\_\_  
Address \_\_\_\_\_  
Phone (\_\_\_\_) \_\_\_\_\_

Sample:      1   EASA                      1   Large Shop  
                  2   Non-EASA                2   Small Shop

Region 1 NE 2 NC 3 NW 4 SE 5 SC 6 SW

Hello. This is [Name] from SBW Consulting in Seattle, and I'm calling about the Motor Repair Survey. This was the time we were scheduled to talk. Is this still a good time?

[If Not: RESCHEDULE      DATE \_\_\_\_\_ TIME \_\_\_\_\_ ]

Okay, let's get started. First, let me define what we mean by motor repair. by repair we mean a major overhaul that typically involves rewinding, bearing replacement, a new shaft, or seals, or some combination of these.

**Motor Repair Shop Characteristics**

Our first questions will help us classify the shops we will be surveying. The information you provide will be kept confidential. [If needed: No information that can be tied to specific firms will be released or reported.]

1. How long has your shop been doing motor repair work?

\_\_\_\_\_ years

2. Which of the following services does your firm offer? [Circle all that apply]

- 1 Motor rewinds
- 2 Motor repairs, other than rewinds
- 3 Repair/refurbish other electrical equipment
- 4 New motor sales
- 5 Sales of other electrical equipment
- 6 Any other major services that we missed [list] \_\_\_\_\_

3. Does your shop have a particular area of specialization? **[If needed:** For example, handling special types of motors or performing special redesigns or repairs?]

---

---

4. Do you contract out some of your repair work? (For example, are formed coils prepared by other shops?) **[If Yes:** What is contracted out?]

- 1 All In House
- 2 Work sub-contracted out

---

5. About what percent of your gross revenues comes from motor repairs?

\_\_\_\_\_ %

6. What was your shop's approximate gross revenue this past year from motor rewinds and repairs? **[This is Question A on the fax.]**

\_\_\_\_\_ (\$000's) **[If Unsure, ask for educated guess, or write in "don't know."]**

7a. How many employees does [shop name] have? **[If needed:]** How many employees are working at your location doing activities including non-repair work?

\_\_\_\_\_ # employees

7b. **[If shop does more than repair/rewind work, ask:]** Of these how many employees work primarily on the motor repair side of the business. Include those who provide indirect support to your motor repair work, like secretarial staff.

\_\_\_\_\_ # employees

8. How many motors did [your firm] rewind in the last year? **[This is Question B on the fax.]**

\_\_\_\_\_ motors

9. Of the motors you repair, what percentage are polyphase AC Induction Motors?

\_\_\_\_\_ %



10. Of the three phase motors you rewind what percentage of rewinds are:

Under 40-hp	_____	%	[This is Question C on the fax.]
From 50 up to 500-hp	_____	%	
Over 500-hp	_____	%	
<b>Total</b>	_____	%	

11. What is the largest motor your shop is equipped to rewind?

\_\_\_\_\_ hp [If they say "no limit," write in "no limit."]

12. What percent of the motors you repair are part of a planned maintenance program, where the motors have not failed?

Planned rotations \_\_\_\_\_%

13. What three types of industries or businesses bring you the largest amount of repair business?  
[This is Question D on the fax.]

	Industry Served
Irrigation	01
Agriculture	02
Food Processing	03
Cement	04
Commercial (buildings)	05
Govmt., military	06
Mining	07
Petroleum/Chemical	08
Primary metal	09 [e.g. steel/aluminum smelting/production]
Pulp and paper	10
Rubber and Plastics	11
Textiles	12
Transportation Equipment	13
Utilities	14
Wood products (Lumber)	15
Other manuf. & services	16

(Specify: \_\_\_\_\_)

**How Customers Choose Repair Services?**

14. I will now read a list of reasons why customers might pick a repair shop. Please rate how important each reason is to your customers. [This is Question E on the fax.] Use the following scale: very important (VI); somewhat important (SI); not too important (NTI); and not important (NI). [Circle DK/NA if respondent doesn't know or if category is not applicable.]

The first one is "low cost." Would you say that's: very important, somewhat important, not too important, or not important?

Low cost.....	VI	SI	NTI	NI	DK/NA
Range of repair services offered.....	VI	SI	NTI	NI	DK/NA
Fast turn-around time.....	VI	SI	NTI	NI	DK/NA
Quality Control/reliability.....	VI	SI	NTI	NI	DK/NA
Technical skills/expertise of staff.....	VI	SI	NTI	NI	DK/NA
High quality materials/components used.....	VI	SI	NTI	NI	DK/NA
Training and support services available for customers.....	VI	SI	NTI	NI	DK/NA
Information and reporting on each repair .....	VI	SI	NTI	NI	DK/NA
Length of working relationship .....	VI	SI	NTI	NI	DK/NA
Other reasons:					
.....	VI	SI	NTI	NI	
.....	VI	SI	NTI	NI	

**Trends in the Motor Repair Industry**

15. Next, I'd like to know if utilities in your service area offer motor rebate programs?

- 1 Yes [respondent is sure]
- 2 Yes/Maybe [respondent thinks so or has heard of one]
- 3 No
- 4 Don't Know

16. [If Yes] Have these programs affected your repair business?  
 [If No] Do you think these programs will affect your repair business?

- 1 Yes
- 2 No
- 3 Don't know

17. [If Yes] How So?

---



---

18. What do you see as the major challenges facing the motor repair business in next decade?

---

---

---

---

---

---

### Motor Repair Specifications

The next few questions have to do with motor repair specifications (for example the number of turns, insulation class, etc.)

19. First, how often do your customers provide you with special repair or test specifications (other than just "return to original condition"), for instance using a special type of varnish or insulation class? Would you say...

1. Very often
2. Somewhat often
3. Not very often
4. Never

20. [If Very, Somewhat or Not Very Often] When customers do provide specifications, what do they typically cover?

---

21. As part of your regular repair procedures, do you routinely do more than return a motor to what you believe is the motor's original condition. (For example, do you use a higher grade of insulation than was originally used.?)

1. Yes
2. No --->[Skip to Question 23]

22. What do you do to improve on a motor's original condition?

---

---

23. Does your shop have more than one repair standard or procedure (e.g "Standard" or "Deluxe Package") that customers can choose from?

- 1 Yes
- 2 No
- 3 Don't know

[If Yes] Could you describe them? \_\_\_\_\_  
\_\_\_\_\_  
\_\_\_\_\_

24. If you have written standards, would you be willing to send us a copy?

- 1 Yes ----> [Give address: SBW Consulting, Inc., 2820 Northup Way, Suite 230, Bellevue, WA 98004-1419, ATTN: Linda Dethman]
- 2 No

25. For the motors you repair, about what percentage of the time is manufacturer's winding data available?

\_\_\_\_\_ %

26. [If not 100%] What are the main reasons you can't get manufacturer's winding data?

\_\_\_\_\_  
\_\_\_\_\_

27. What do you do when you don't have manufacturer's winding data?

\_\_\_\_\_  
\_\_\_\_\_

28. If manufacturers' winding data could be obtained with a telephone call or FAX within an hour, would you use that service?

- 1 Yes
- 2 No

### Quality Assurance

Next, I would like to ask you a few questions about your shop's quality assurance procedures and standards. By quality assurance procedures, I mean written shop policies covering things like testing, burnout procedures and record-keeping.

29. Does your shop use formal, written quality assurance procedures?

- 1 Yes
- 2 No ----> [Skip to Question 31]

30. [If Yes] Could you describe them briefly? What do they cover?

---

---

31. Do you keep records about the motors your repair?

- 1 Yes
- 2 No

32. [If Yes] What type of records do you keep? (For example: index cards, computer files)

---

---

### Testing Equipment and Practices

33. Next I'll ask you about different types of motor testing equipment. First, does your shop use a...

	Yes	No	Don't Know
Megohmmeter (Megger)	1	2	3
DC High Potential (Hi-Pot)	1	2	3
AC Hi Pot	1	2	3
Surge tester	1	2	3
Three phase wattmeter	1	2	3
Low-resistance ohmmeter	1	2	3
Vibration tester	1	2	3
Acoustic tester	1	2	3
Dynamometer	1	2	3

34. What is the range in HP or torque for the Dynamometer?

\_\_\_\_\_ HP/ \_\_\_\_\_ Torque [Write N.A. if not applicable.]

35. Do you have a core loss tester?

	Yes	No	Don't Know
----->	1	2	3

36. [If Yes], What type is that?

- 1 Lexseco
- 2 Phenix
- 3 Other

37. Do you have a auto transformer or other controller to adjust voltages for motor testing to exactly equal nameplate voltages?

----->                      Yes      No    Don't Know  
    1        2        3

38. What standard voltages can you provide for motor testing, with or without an auto transformer or other controller?

	With Cntrlr.	Without Cntrlr.
208 V	1	2
240 V	1	2
480 V	1	2
600 V	1	2
2400 V	1	2
4160 V	1	2
Other:	1	2
_____	1	2
_____	1	2
_____	1	2

No load current or power testing

Next I will ask you about motor testing procedures during motor repairs.

39. The first type of testing is No-load current and/or power testing. Does your shop do No-load (i.e. motor running) testing during motor repair?

- 1 Yes ---> [Continue]
- 2 No ---> [Go to Question 43]

40. When working motors come in for testing, what percent are given no-load tests before disassembly?

\_\_\_\_\_ %

40b. What percent are tested after repair?

\_\_\_\_\_ %

41. Under what circumstances is No-load testing not done, or done at reduced voltage? Are certain motor types more or less likely to be tested?

\_\_\_\_\_

\_\_\_\_\_

42. Do you keep records on the results of no load testing for individual motors?

- 1 Yes
- 2 No

No load vibration testing

43. The next test I'd like to ask about is vibration testing with the motor running. Does your shop do vibration testing during motor repair?

- 1 Yes ----> [Continue]
- 2 No ----> [Skip to Question 49]

44. Vibration testing might be done before working motors are taken apart and/or after they are reassembled. About what percent of the time do you conduct No-load vibration tests on the motors your shop repairs before disassembly? After reassembly?

\_\_\_\_\_ % Before disassembly  
\_\_\_\_\_ % After reassembly

45. Under what circumstances is vibration testing not done? Are certain motor types more or less likely to be tested?

---

---

46. How do you determine acceptable vibration limits?

---

---

47. What type of motor mounting do you use during vibration testing?

- 1 Elastic Foundation
- 2 Rigid Base

48. How often do you check the dynamic balance of motor rotors?

- 1 All jobs
- 2 Most jobs
- 3 Some jobs
- 4 Few or no jobs

[If not All Jobs] When is it done?

---

---

Performance or Load Testing

49. The next test I'll ask about is performance or load testing with the motor running and the motor shaft coupled to a brake or dynamometer. Does your shop do load testing during motor repair?

- 1 Yes ----> [Continue]
- 2 No ----> [Skip to Question 52]

50. Load testing might be done before motors are taken apart and/or after they are reassembled. About what percent of the time do you conduct Load tests on the motors your shop repairs before disassembly? After reassembly?

\_\_\_\_\_ % Before disassembly  
\_\_\_\_\_ % After reassembly

51. Under what circumstances is performance testing done? Are certain motor types more or less likely to be tested?

---

---

Testing for insulation condition

52. I'd also like to ask about testing for insulation condition. This includes using a Megohmmeter (Megger), Hi-Pot, or Surge tester. Does your shop test insulation condition during motor repair?

- 1 Yes ----> [Continue]
- 2 No ----> [Skip to Question 57]

53. About what percentage of motors are typically tested for insulation condition?

\_\_\_\_\_ %

54. When is that testing typically done? [Read the list and circle all that apply]  
[ For each selection circled ask:] When testing [name option] what testing instrument do you use? (i.e. 1-Hi Pot, 2-Megger, or 3-Surge tester)?

- 1 Before disassembly; [Instrument used:] \_\_\_\_\_
- 2 After disassembly but before winding removal [Instrument used:] \_\_\_\_\_
- 3 After rewinding but before reassembly [Instrument used:] \_\_\_\_\_
- 4 After reassembly [Instrument used:] \_\_\_\_\_
- 5 Other \_\_\_\_\_



55. Under what circumstances is insulation testing not done? Are certain motor types more or less likely to be tested?

---

---

56. How do you determine the acceptable limits or conditions for the insulation tests?

---

---

Winding Resistance Testing

57. Next I'll ask about testing for Winding Resistance. Does your shop measure winding resistance during motor repair?

- 1 Yes ----> [Continue]
- 2 No ----> [Skip to Question 62]

58. About what percent of motors get winding resistance tests?

\_\_\_\_\_ %

59. When is that testing typically done? [Do not read list; circle all that apply]

- 1 Before disassembly
- 2 After disassembly but before winding removal
- 3 After rewinding but before reassembly
- 4 After reassembly

60. Under what circumstances is winding resistance testing done? Are certain motor types more or less likely to be tested?

---

---

61. If design winding resistance were on the nameplate or easy to access [like in an EASA BBS or computer database], would you perform such testing routinely?

Yes \_\_\_\_\_ No \_\_\_\_\_

Core-Loss Testing

62. Finally, I would like to ask you about Core Loss Testing. Does your shop do core-loss testing during motor repair or do you have procedures for doing a loop test (e.g. wind cable around core and feel for hot spots)?

- 1 Yes, core loss tester ----> [Continue]
- 2 Yes, loop tests
- 3 No -----> [Skip to Question 66]

63. About what percentage of motors get core-loss or loop tests?

\_\_\_\_\_ %

64. When is that testing typically done? [Do not read list; circle all that apply]

- 1 After disassembly but before winding removal
- 2 After winding removal
- 3 After rewinding but before reassembly

65. Under what circumstances is core-loss testing not done? Are certain motor types more or less likely to be tested.

---

---

**Winding Removal**

66. Let's shift gears and talk about removing windings. What methods does your shop use to remove old motor windings? [Circle all that apply]

- 1 Burn out/oven
  - 2 Chemical stripping
  - 3 Other
- Specify \_\_\_\_\_

67. [If Chemical Stripping and Burn out] What percentage of windings do you chemically strip?

\_\_\_\_\_ %

68. What chemical is used in stripping? [Circle all used]

- 1 Perchloroethylene
  - 2 Trichloroethylene
  - 3 Methylene chloride
  - 4 Oakite
  - 5 X300
  - 6 Other
- Specify \_\_\_\_\_

69. [For those Using Burn-out] Does (Do) the oven(s) have temperature controls?

- 1 Yes, all ovens
- 2 Some
- 3 None
- 4 Don't Know

[If 1 or 2 above] Are sensors placed in the core or in the oven chamber?

- 1 Core
- 2 Oven Chamber

70. How often are the controls calibrated?

\_\_\_\_\_

71. What temperature setting is typically used?

\_\_\_\_\_ °F

72. Do the oven(s) have a water suppression system?

- 1 Yes
- 2 No
- 3 Don't know

73. How long is your burnout time? If variable, how is burnout time determined?

\_\_\_\_\_

\_\_\_\_\_

## Winding Questions

74. When rewinding standard T-frame or U-frame motors, how often do you put more copper in the slots (i.e. larger wire without reducing turns, or different strand combinations that total more circular mils) for improved efficiency?

\_\_\_\_\_ %

75. Why is larger wire added?

---

---

76. Are there any problems winding with at least the original wire size? [If yes: What are they?]

---

---

77. Do you ever change the winding configuration (e.g. concentric to lap or vice versa)?

Yes \_\_\_\_\_ No \_\_\_\_\_

Why? \_\_\_\_\_

## High Efficiency Motors

78. I'd now like to ask about standard motors and energy efficient motors. First, I would like to find out how you define an energy efficient motor.

---

---

---

---

---

---

---

In this interview, I will define energy efficient motors as ones that must meet the efficiencies shown in NEMA MG1-Table 12 - 6C, or roughly the upper third of the motor population if they were ranked by energy efficiency. Such motors would often, but not always, have special bearings, unconventional wire sizes, small fans, tightly packed windings, or closer than usual tolerances that make them more efficient.

79. When a motor comes into your shop for repair do you check whether or not it is an energy efficient motor?

---

---

80. What percent of the energy efficient motors you repair require using other than your normal procedures, parts, or materials to restore to original condition?

\_\_\_\_\_ %

81. Are energy efficient motors more difficult to repair to original specifications?

- 1 Yes
- 2 No
- 3 Don't Know

82. In your shop, about what percent of the energy efficient motors are rewound with the identical wire gage and turns to match the original energy efficient specs?

\_\_\_\_\_ %

83. What percent of the time do you replace fans on energy efficient motors with the same size fan?

\_\_\_\_\_ %

84. Are there special problems with repairing some energy efficient motors to original efficient condition (e.g. bearings with original or less friction, windings with at least same gage or equivalent circular mils, etc.)? What are they? Are there specific types of motors that are problematic?

---

---

---

---

### Repair Costs for Energy Efficient Motors

85. Do you charge more to repair energy efficient motors compared to similar size standard motors?

- 1 Yes ----> [Continue]
- 2 No ----> [Go to Question 93]

86. What adds to repair costs for energy efficient motor repairs (labor, parts etc)? What is the largest contributor?

---

---

---

86a. We are interested in the cost differences between repairing standard and energy-efficient motors. As a point of comparison we will use a 100 hp, 4-pole TEFC motor. For the purpose of the following question the standard non-energy efficient motor is one with 92.6% energy efficiency. The energy efficient motor is one with 95.2% energy efficiency.

[If asked about efficiency, clarify: This standard motor would not meet NEMA's 12-6B standard. The energy efficient motor is defined as a motor with 95.2% energy efficiency or better. This motors exceeds the NEMA 12-6C standard.]

87. For this 100 hp motor, what is the percent increase in overall costs for repairing energy efficient motors over a standard motor with the same specs?

\_\_\_\_\_ %

88. For this 100 hp motor, what is the average percentage increase in parts and materials costs for repairing an energy efficient motor over a standard motor?

\_\_\_\_\_ %

89. Would the percentage difference in parts and materials costs be larger, smaller, or the same if the comparison point was a 200 hp motor? What if the comparison point was a 10 hp motor?

	200 hp		10 hp
1	Larger	1	Larger
2	Smaller	2	Smaller
3	The Same	3	The Same

90. Approximately how many labor hours are needed for the average repair/rewind of a standard 100 hp motor?

\_\_\_\_\_ hours

91. Approximately how many additional labor hours are needed for repairing an energy efficient 100 hp motor over a standard 100 hp motor?

\_\_\_\_\_ hours

92. How many additional hours are needed for repairing an energy efficient 200 hp motor over a standard motor?

\_\_\_\_\_ hours

## Variable Frequency Drive (VFD) Service

93. Now I have a few questions about motors used in connection with variable frequency drives (VFDs)? Do you repair motors which are designed to be used with VFDs, e.g. those designated "inverter duty"?

- 1 Yes
- 2 No ----> [Skip to Question 98]

94. What percent of the motors you repair are designated "inverter duty" for VFDs? ["Inverter Duty" appears on the nameplates of motors that are specially designed to work with VFDs or ASDs (adjustable speed drives)]

\_\_\_\_\_ %

95. About what percent of the motors you repair are used with VFDs but not labeled "inverter duty" for this purpose?

\_\_\_\_\_ %

96. What extra measures do you take to reinforce repaired motors that you know will be used with variable frequency drives (VFDs)?

---

---

---

---

97. Do you charge extra to rewind...

- conventional motors that will be used with VFDs? Yes \_\_\_\_\_ No \_\_\_\_\_
- motors that are designated "inverter duty" for use with VFDs? Yes \_\_\_\_\_ No \_\_\_\_\_

## Summary Questions

Now I have some final, general questions.

98. What are the most important steps to take in maintaining high efficiency in the motors you repair?

---

---

---

---

99. What are the biggest problems in maintaining energy efficiency? What holds you back?

---

---

---

100. For what percent of repair jobs do cost or turn-around time prevent you from repairing a motor to its best possible energy efficiency?

\_\_\_\_\_ %

101. What information do you need from manufacturers to maintain or improve motor energy efficiency?

---

---

---

---

102. What information do you need from industry about their motors to maintain or improve motor energy efficiency when you repair motors?

---

---

---

---

103. Can you make any suggestions for efficiency enhancement more specific or unique than "rebuild to original configuration"?

---

---

---

---

104. Is there anything else you would like to comment on concerning energy efficient motor repairs?

---

---

---

---



105. That's the last question. As I mentioned earlier a copies of the survey results will be available to participants in the survey. Would you like one sent to you?

- 1 No
- 2 Yes [confirm address]

---

---

---

---

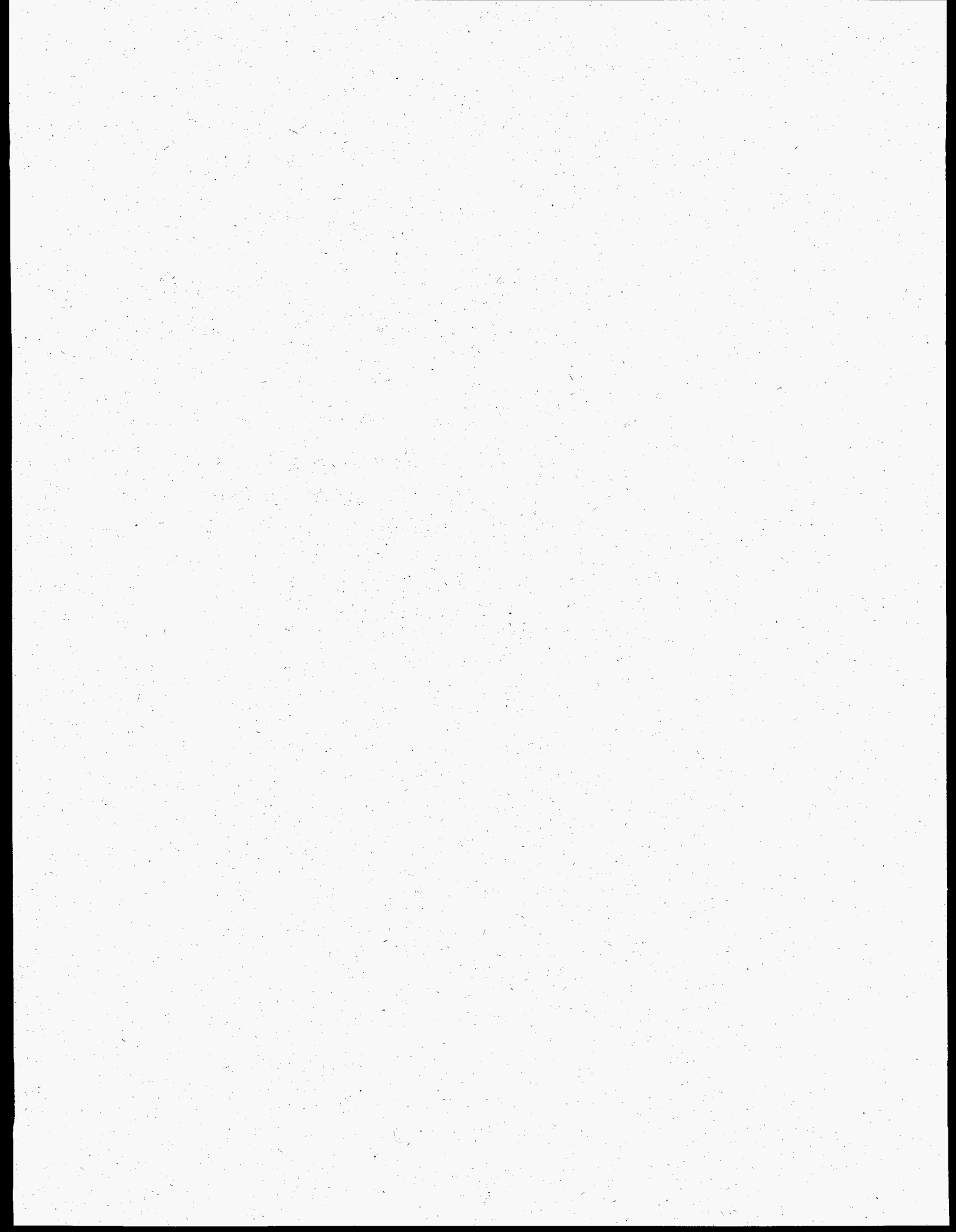
Thank you for your time and participation.

**If the respondent wants more information on the motor repair shop study, please have them contact:**

**Johnny Douglas  
Principal Investigator  
Washington State Energy Office  
(206) 956-2034**

# **Appendix C**

## **Motor Efficiency Losses: Types, Causes, Diagnosis, and Remedies**



## Motor Efficiency Losses: Types, Causes, Diagnosis, and Remedies

Categories of Efficiency Losses	Explanation of Losses	Shop Actions that Contribute to Losses	Diagnosis of Efficiency Problems	Preventing or Correcting Efficiency Losses
<p>WINDAGE AND FRICTION LOSSES</p> <p>5 to 15 percent of total losses.*</p>	<p>Friction and windage losses result from:</p> <ul style="list-style-type: none"> <li>• Friction in the bearings.</li> <li>• Air friction (resistance) against the rotating fan and ventilation air paths.</li> </ul> <p>These losses do not normally vary with load.</p>	<ul style="list-style-type: none"> <li>• Damaged bearings replaced with type (or brand) other than, or of lower quality than, mfg. specs.</li> <li>• Change in type of grease or overgreasing.</li> <li>• Substitution of an oversize or less efficient fan than original mfg. specs.</li> <li>• Assembly procedures: Mechanical modifications to bearings and seals can affect friction losses. Knurling, peening, or painting bearing fits can cause bearings to become loose in service and increase friction losses and cause early bearing failure.</li> </ul>	<p>No Load Test: Measure no load losses at rated and several reduced voltages. The watts are plotted vs. the points and windage losses are equal to the square of the no load losses at zero volts. (Motor must be operational to perform test.)</p>	<p>Repair motor with mfg. type of bearings, grease, fan, or other parts.</p> <p>Do not damage bearings during assembly.</p> <p>Record steps taken during repair, the types of parts that motor came in with, and replacement parts used.</p>

Categories of Efficiency Losses	Explanation of Losses	Shop Actions that Contribute to Losses*	Diagnosis of Efficiency Problems	Preventing or Correcting Efficiency Losses
<p>CORE LOSSES</p> <p>15 to 25 percent of total losses.*</p>	<p>Core loss represents two types of losses: hysteresis and eddy currents.</p> <ul style="list-style-type: none"> <li>Hysteresis is a change in the properties of the iron in the core because of overheating during burnout. Hysteresis increases the energy required to magnetize the core material.</li> <li>Eddy currents result from inadequate or damaged insulation between the core laminations that give rise to circulating currents between laminations.</li> </ul> <p>These losses do not normally vary with load.</p>	<p>Overheating core:</p> <ul style="list-style-type: none"> <li>Temperatures that are too high or fluctuate excessively during burnout (including fires that ignite in the stator) can cause the insulation between the stator laminations to break down, increasing eddy current losses.</li> <li>Stacking motors in the oven or putting small stators inside the bores of larger ones interferes with temperature control and consistency in the oven.</li> <li>Use of an open flame (uncontrolled heat) to burn out old windings causes loss of core plating and warps cores.</li> </ul> <p>Mechanical damage to laminations:</p> <ul style="list-style-type: none"> <li>Sand blasting the core can cause shorts between laminations.</li> <li>Grinding laminations or filing slots can cause shorts between laminations.</li> <li>During repair, the insulation between laminations can be degraded by mishandling, burrs, or assembly pressure.</li> </ul>	<p>Core Loss Test (measures power consumed by hysteresis and eddy currents):</p> <ul style="list-style-type: none"> <li>Test each motor when it is received for repair.</li> <li>Test before and after winding is stripped out to ensure no increase in core loss during stripping.</li> <li>Test again after any repair to the iron.</li> <li>Physically inspect core to see whether too badly damaged to repair.</li> </ul> <p>Loop Test (a.k.a. Ring Test): (See EASA Tech Note 17 for recommended procedure.) Recent, unpublished testing by Quebec Hydro suggests that the results obtained from EASA Tech. Note 17 core loop testing compares favorably with results obtained from commercial core loss testers.</p> <p>Alternative Test Method:</p> <ul style="list-style-type: none"> <li>No Load Test: Core losses can be calculated by subtracting friction and windage losses from the total no load losses (motor must be operational).</li> </ul>	<p>Burnout:</p> <ul style="list-style-type: none"> <li>Use controlled temperature burnout oven.</li> <li>Keep the temperature as low as practical—ideally below 650°F.</li> <li>Regularly calibrate oven temp.</li> <li>Use a water spray system to help control temperature.</li> <li>Position stators vertically inside the oven, or at 90° angles to adjacent stators and oven walls.</li> <li>Don't stack motors in oven or place a stator inside a larger stator.</li> <li>Don't use an open flame for stripping.</li> </ul> <p>Mechanical:</p> <ul style="list-style-type: none"> <li>Don't grind laminations or file the slots.</li> <li>Use glass beads, walnut shells, corn cobs, or similiar materials to blast cores; don't use sand or other hard materials.</li> <li>When removing varnish from the stator bore after baking, use a wire brush or soft grinding material to avoid enlarging the diameter of the bore or causing shorts in the laminations.</li> <li>Repair or replace defective laminations.</li> </ul> <p>Record steps taken during repair, the types of parts that motor came in with, and replacement parts used.</p>

Categories of Efficiency Losses	Explanation of Losses	Shop Actions that Contribute to Losses	Diagnosis of Efficiency Problems	Preventing or Correcting Efficiency Losses
<p>STATOR WINDING LOSSES</p> <p>25 to 40 percent of total losses.*</p> <p>Stator winding losses vary with load.</p>	<p>I<sup>2</sup>R losses: Stator losses appear as heating because of current flow (I) through the resistance (R) of the stator winding. This is commonly referred to as I<sup>2</sup>R loss.</p>	<p>Wire size: If the diameter of the wire used does not equal or exceed the circular mils of the original mfg wire or of wire substituted in a previously (well-designed) motor upgrade or redesign.</p> <p>Number of turns: Fewer turns than mfg. specs. lowers winding resistance and increases current (I).</p> <p>Coil length: Too many turns or a redesign of the winding can cause crowding at the ends and increases resistance.</p> <p>Change in winding design: This type of change can affect stray load losses and increase winding resistance, unless part of a properly-engineered redesign to convert motor to operate in different operating conditions (e.g. different voltage or frequency).</p> <p>Increased air gap: Enlarging the diameter of the stator bore or taking a cut off the rotor increases the air gap. This produces a higher magnetizing (no-load) current, which increases stator and rotor copper losses and usually decreases power factor.</p>	<p><b>Stator Winding Resistance Test:</b> Check for I<sup>2</sup>R losses. This test will not pick up all energy efficiency problems.</p> <p><b>Surge Comparison Test:</b> Will identify unequal windings (e.g. a dropped turn).</p> <p><b>Dynamometer Test:</b> Used primarily to test overall efficiency of motors in lab testing. Time consuming and expensive.</p> <p><b>DC High Potential/ Insulation Resistance Test:</b> Basic test done routinely by most shops as a first step. Provides a pass/fail test of adequacy of insulation.</p>	<p>Measure wire size carefully.</p> <p>Before disturbing the winding, carefully measure and record the coil winding pattern.</p> <p>Count the turns carefully.</p> <p>Use wire, or strands, with at least the same circular mils as original mfg. wire. Use same number of turns as original.</p> <p>When making replacement coils, measure the wire after the first group of coils has been wound. Too much tension can stretch the wire, thereby decreasing its diameter and increasing resistance and stator copper losses.</p> <p>Don't change the winding design (e.g. from concentric to lap or vice versa).</p> <p>Clean motor to ensure effective cooling.</p> <p>Replace aluminum wire with copper wire.</p> <p>Record steps taken during repair, the types of parts that motor came in with, and replacement parts used.</p>

Categories of Efficiency Losses	Explanation of Losses	Shop Actions that Contribute to Losses	Diagnosis of Efficiency Problems	Preventing or Correcting Efficiency Losses
<p><b>ROTOR LOSSES</b></p> <p>15 to 25 percent of total losses.*</p> <p>Rotor losses vary with load.</p>	<p><math>I^2R</math> losses--heating in the rotor cage or winding.</p>	<p>Loose or cracked conductor bars not detected and repaired or replaced.</p> <p>Conductor bars replaced with bars smaller than originals.</p> <p>Degradation of air gap symmetry:</p> <ul style="list-style-type: none"> <li>• Machining or grinding rotor causing a reduction in the diameter of the rotor.</li> <li>• Bent shaft not detected and straightened.</li> <li>• Damage to endshields.</li> </ul> <p>Blockage of air passages.</p>	<p><b>No-Load Test:</b> Vibration testing during no-load test will reveal if rotor is out of balance.</p> <p><b>Growler Test and "Feel" Test:</b> To identify damaged bars.</p> <p><b>Visual Test:</b> To identify loose bars in end ring.</p>	<p>Check for loose or damaged conductor bars.</p> <p>Repair loose bars, replace damaged bars with same type/size bars as original mfg. specs.</p> <p>Balance rotor; straighten bent shaft.</p> <p>Clean rotor to ensure effective cooling.</p> <p>Record steps taken during repair, the types of parts the motor came in with, and replacement parts used.</p>
	<p>Rotor core damage</p>	<p>Damage to rotor core such as smearing of laminations.</p>	<p>Visual inspection.</p>	<p>Don't damage rotor core laminations.</p> <p>Repair or replace damaged laminations.</p>
<p><b>STRAY LOAD LOSSES</b></p> <p>10 to 20 percent of total losses.*</p>	<p>Stray load losses include all efficiency losses not accounted for by windage and friction, stator core, stator <math>I^2R</math>, and rotor <math>I^2R</math> losses.</p> <p>These losses vary as the square of the load current</p>	<p>Damage to rotor laminations:</p> <ul style="list-style-type: none"> <li>• If the rotor is turned to eliminate a rubbing problem, and a dull tool is used that smears the iron, the stray load losses will be increased.</li> </ul> <p>Change in the winding design.</p> <p>Increase in air gap:</p> <ul style="list-style-type: none"> <li>• Damaged stator or rotor cores, frames, or endshields can affect air gap symmetry or increase the size of the air gap.</li> <li>• If in repairing a motor, the rotor must be turned, the air gap will increase. This change will increase the no load current, which results in higher stray load losses.</li> <li>• If endshield repair or replacement is required, and the rotor and stator are longitudinally misaligned, there will be a reduced air gap area across which power can be transmitted, increasing the stray load losses.</li> </ul>	<p>Stray load losses are difficult to measure and usually vary considerably more than the other types of losses.</p> <p>The costs in time and money of accurately measuring stray load losses in a motor will outweigh the benefits for most motor repair shops. Repair shops should instead concentrate on avoiding actions that increase stray load loss.</p>	<p>Take care not to damage rotor laminations</p> <p>Use the same winding design as mfg. specs.</p> <p>Ensure that the air gap is not increased and is symmetrical.</p> <p>Record steps taken during repair, the types of parts that motor came in with, and replacement parts used.</p>

\*WSEO, *Energy-Efficient Electric Motor Selection Handbook*, Revision 2, February 1992, p. 11.

## Energy Efficiency Testing Requirements and Approaches for Motor Repair/Rewinds

General Areas of Testing	What's Being Tested	Description of Tests	Equipment Required	When Should Tests be Done?	How regularly should tests be done?	Comment
<b>INSULATION</b>	Insulation of all electric components in the motor.	To ground - Polarization Index >2.	Surge Tester High Potential Tester (Hi-Pot) Megohmmeter	<ul style="list-style-type: none"> <li>• Before winding removal.</li> <li>• Before impregnation.</li> </ul>	Diagnostic	Unless insulation clearly damaged.
	Insulation between coil groups and phases.	Phase to phase.	Surge Tester High Potential Tester (Hi-Pot) Megohmmeter	<ul style="list-style-type: none"> <li>• After varnish and before reassembly.</li> </ul>	Always	
	Insulation between individual wires in a single coil.	Turn to turn.	Surge Tester	<ul style="list-style-type: none"> <li>• After reassembly.</li> </ul>	Conditional	If not done after varnish.
<b>WINDING RESISTANCE</b>	Number of turns: resistance related to the number of turns.		Milliohmmeter Wheatstone Bridge	<ul style="list-style-type: none"> <li>• Before winding removal.</li> </ul>	Diagnostic	
	Equity of turns: compare resistance from one phase to another.		Milliohmmeter Surge Tester	<ul style="list-style-type: none"> <li>• After rewinding and before impregnation</li> </ul>	Always	
	Wire size and length: compare resistance to mfg. specs. or baseline.		Milliohmmeter			
	Winding pattern: compare resistance to mfg. specs. or baseline.		Milliohmmeter Surge Tester			



General Areas of Testing	What's Being Tested	Description of Tests	Equipment Required	When Should Tests be Done?	How regularly should tests be done?	Comment
<b>STATOR CORE CONDITION</b>	Efficiency losses because of hysteresis and bridging of core interlaminar insulation, which leads to eddy current losses.	Core loss test	Core Loss Tester	<ul style="list-style-type: none"> <li>• Before winding removal</li> <li>• After burnout and before rewind</li> </ul>	Diagnostic	To establish baseline
		Loop test (a.k.a. ring test)	Wattmeter		Always	To determine any degradation caused by burnout
	Check for hot spots	Inspection by feel or temperature reading device				
	Excessive current and power caused by core damage.	No load running test: compare current and power results to mfg. specs.	Wattmeter Ammeter	<ul style="list-style-type: none"> <li>• Before disassembly</li> <li>• After reassembly</li> </ul>	Always/ Diagnostic	If no core loss test is done
<b>ROTOR/BEARINGS MECHANICAL</b>	Damage to Bearings	Bearing noise (not always audible to human ear).	Use instrument, such as a vibration analyzer, designed to sense bearing noise energy.	Before disassembly.	Always/ Diagnostic	
	Bent shaft					
	Unbalanced rotor	Vibration of motor at no-load running.	Vibration Sensor	Before disassembly.	Always	
		Vibration of rotor in balancing.	Balance Stand Vibration Sensor	Before reassembly.	Always	
Rotor runout		Balance Stand Dial indicator	Before reassembly.	Always		

General Areas of Testing	What's Being Tested	Description of Tests	Equipment Required	When Should Tests be Done?	How regularly should tests be done?	Comment
<b>ROTOR ELECTRICAL</b>	Damaged, cracked, or loose rotor bars and end rings.	Visual inspection and by feel.	Eyes and fingers	Before reassembly.	Always/ Diagnostic	
	Cracked or loose bars.	Growler Test.	Growler  Stator: Apply power to two leads of an assembled three-phase motor; hand-rotate rotor; monitor ammeter for deviation in current, which would indicate a rotor fault.	Before reassembly.	Always	
	Cracks not detectable by sight or feel.	Ultrasonic Test	Ultrasonic	Before reassembly.	Conditional	Only for larger motors.
	Rotor core damage.	Visual	Eyes	Before reassembly.	Always	
<b>Overall Condition</b>	Balance of line currents no load speed.	No load test at rated voltage.	Ammeter Tachometer	Final inspection.	Always	
	Full load temperature rise.	Heat run.	Dynamometer	Final inspection.	Conditional	On client request.