

ornl

RECEIVED

APR 30 1996

OSTI

**OAK RIDGE
NATIONAL
LABORATORY**

LOCKHEED MARTIN 

**High Explosives Vapor Detection by
Atmospheric Sampling Glow Discharge
Ionization/Tandem Mass Spectrometry**

Scott A. McLuckey
Douglas E. Goeringer
Keiji G. Asano

MANAGED BY
LOCKHEED MARTIN ENERGY SYSTEMS, INC.
FOR THE UNITED STATES
DEPARTMENT OF ENERGY

UCN-13673 (38 6-95)

MASTER

DISTRIBUTION OF THIS DOCUMENT IS UNLIMITED 

Scott A. McLuckey

This report has been reproduced directly from the best available copy.

Available to DOE and DOE contractors from the Office of Scientific and Technical Information, P.O. Box 62, Oak Ridge, TN 37831; prices available from (423) 576-8401, FTS 626-8401.

Available to the public from the National Technical Information Service, U.S. Department of Commerce, 5285 Port Royal Rd., Springfield, VA 22161.

This report was prepared as an account of work sponsored by an agency of the United States Government. Neither the United States Government nor any agency thereof, nor any of their employees, makes any warranty, express or implied, or assumes any legal liability or responsibility for the accuracy, completeness, or usefulness of any information, apparatus, product, or process disclosed, or represents that its use would not infringe privately owned rights. Reference herein to any specific commercial product, process, or service by trade name, trademark, manufacturer, or otherwise, does not necessarily constitute or imply its endorsement, recommendation, or favoring by the United States Government or any agency thereof. The views and opinions of authors expressed herein do not necessarily state or reflect those of the United States Government or any agency thereof.

CONTENTS

LIST OF FIGURES	v
ABSTRACT	vii
1. INTRODUCTION	1
2. INSTRUMENTATION FOR ATMOSPHERIC SAMPLING GLOW DISCHARGE IONIZATION/ION TRAP MASS SPECTROMETRY	3
3. ATMOSPHERIC SAMPLING GLOW DISCHARGE FOR ANION FORMATION	7
4. TANDEM MASS SPECTROMETRY	13
4.1. BEAM-TYPE TECHNOLOGIES	17
4.2. TRAPPING TECHNOLOGIES	20
5. QUADRUPOLE ION TRAP TANDEM MASS SPECTROMETRY FOR ANION ANALYSIS	29
6. SUMMARY	45
REFERENCES	47
ACKNOWLEDGEMENTS	53
Appendix I - Titles of research papers resulting from OSS sponsorship	55
Appendix II - U.S. Patent 5,206,509 resulting from OSS sponsorship	61
Appendix III - Titles of other ORNL papers of direct relevance to high explosives detection	77
Appendix IV - Machine drawings for glow discharge ion trap housed in 6" cube	81
Appendix V - Machine drawings for adapting a Teledyne 3DQ ion trap for atmospheric sampling glow discharge	93

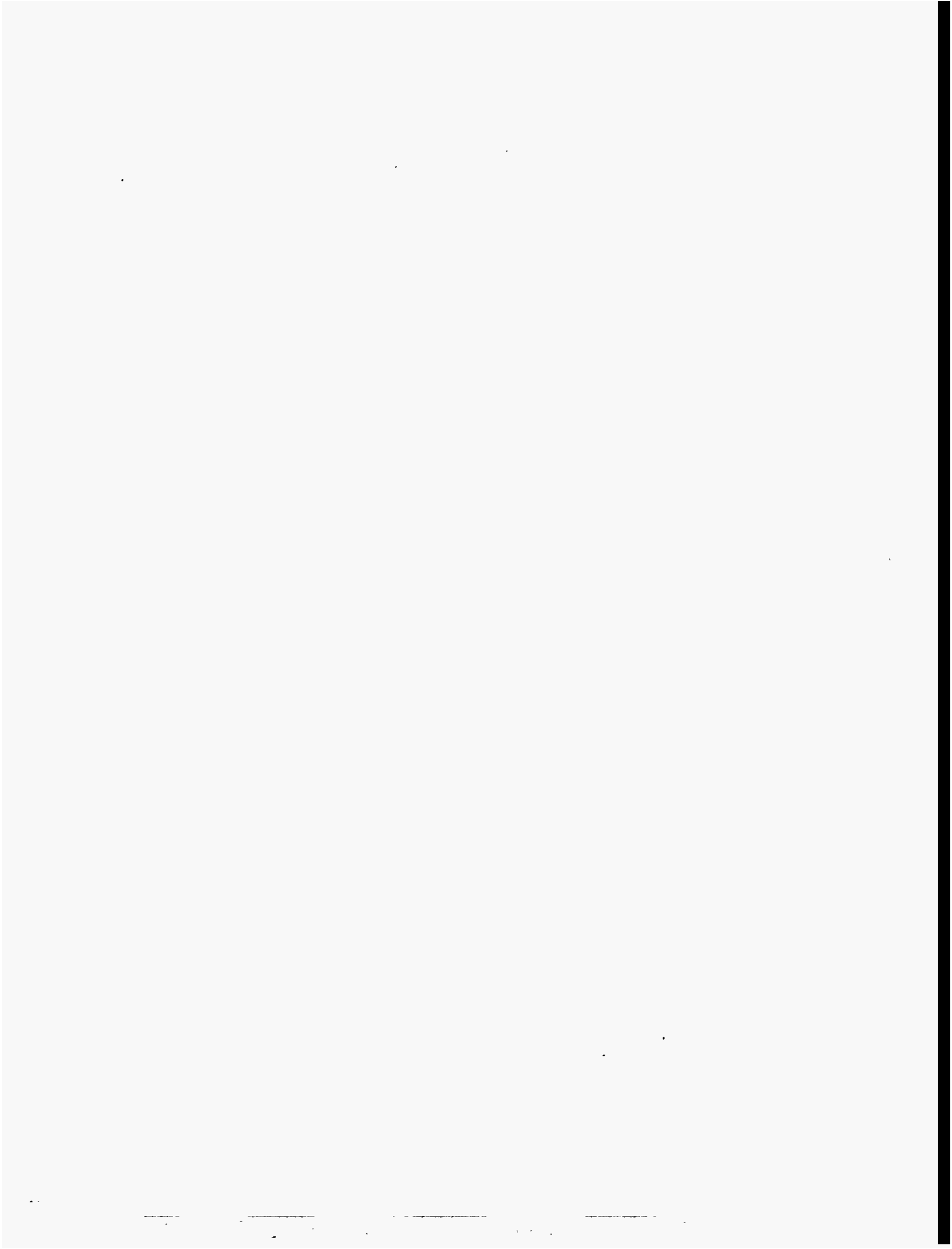

LIST OF FIGURES

Figure 1.	A side-view schematic of an ASGDI source interfaced with a Finnigan ITMS®. Operating characteristics of this instrument are listed in Table 1.	4
Figure 2.	Schematic comparison of GC/MS with MS/MS.	14
Figure 3.	Schematic representation of the ASGDI MS/MS experiment for explosives detection.	16
Figure 4.	Some common MS/MS instrumental configurations.	18
Figure 5.	Photograph of the quadrupole ion trap assembly; two endcap electrodes and a ring electrode.	22
Figure 6.	Schematic representation of the electric fields experienced by an ion for a large positive voltage and for a large negative voltage.	23
Figure 7.	Side-view schematic of the ion trap with a sinusoidal signal applied to the end-caps to effect resonance ejection.	24
Figure 8.	Illustration of the MS/MS efficiency for the $(M-CH_2ONO_2)^-$ anion derived from PETN: (a) spectrum of isolated parent ion (b) spectrum after resonance excitation.	31
Figure 9.	Illustration of the MS/MS efficiency for the $(M-NO_2)^-$ anion derived from RDX: (a) spectrum of isolated parent ion (b) spectrum after resonance excitation.	32
Figure 10.	MS/MS spectrum of the $(M-NO_2)^-$ parent ion from a 500 fg sample of RDX admitted into a heated region leading to the inlet of the ASGDI source. The insert shows the total ion chromatogram associated with admission of the RDX sample into the heated inlet.	33
Figure 11.	MS/MS spectrum of 2,4,6-trinitrotoluene obtained using single frequency resonance excitation.	34

Figure 12. Molecular anions signals of 2,4-dinitrotoluene obtained as a function of ion accumulation time with (filled circles) and without (filled triangles) the use of a filtered-noise field to effect mass selective ion accumulation. 37

Figure 13. ASGDI mass spectra derived from sampling head space vapors of black powder in the absence of mass selective ion accumulation (a) and using a filtered-noise field to allow for the selective accumulation of ions at m/z 64, 96, and 128 (b). 39

Figure 14. ASGDI mass spectra derived from sampling a mixture of RDX, PETN and TNT in the absence of mass selective ion accumulation (a) and using a filtered-noise field to allow for the selective accumulation of ions within mass/charge windows of m/z 172-180, m/z 223-232, and m/z 235-245 (b). . . 41

Figure 15. Spectrum resulting from the use of consecutive filtered-noise fields to effect parallel monitoring for RDX, PETN, and TNT. The first filtered-noise field was used to mass selectively accumulate ions within the mass/charge windows of m/z 172-180, m/z 223-232, and m/z 235-245. The second filtered noise field was use to collisionally activate ions at m/z 176, 227, and 240. 43

ABSTRACT

The combination of atmospheric sampling glow discharge ionization with tandem mass spectrometry for the detection of traces of high explosives is described. Particular emphasis is placed on use of the quadrupole ion trap as the type of tandem mass spectrometer. Atmospheric sampling glow discharge provides a simple, rugged, and efficient means for anion formation while the quadrupole ion trap provides for efficient tandem mass spectrometry. Mass selective ion accumulation and non-specific ion activation methods can be used to overcome deleterious effects arising from ion/ion interactions. Such interactions constitute the major potential technical barrier to the use of the ion trap for real-time monitoring of targeted compounds in uncontrolled and highly variable matrices. Tailored waveforms can be used to effect both mass selective ion accumulation and ion activation. Concatenated tailored waveforms allow for both functions in a single experiment thereby providing the capability for monitoring several targeted species simultaneously.

The combination of atmospheric sampling glow discharge ionization with a state-of-the-art analytical quadrupole ion trap is a highly sensitive and specific detector for traces of high explosives. The combination is also small and inexpensive relative to virtually any other form of tandem mass spectrometry. The science and technology underlying the glow discharge/ion trap combination is sufficiently mature to form the basis for an engineering effort to make the detector portable.

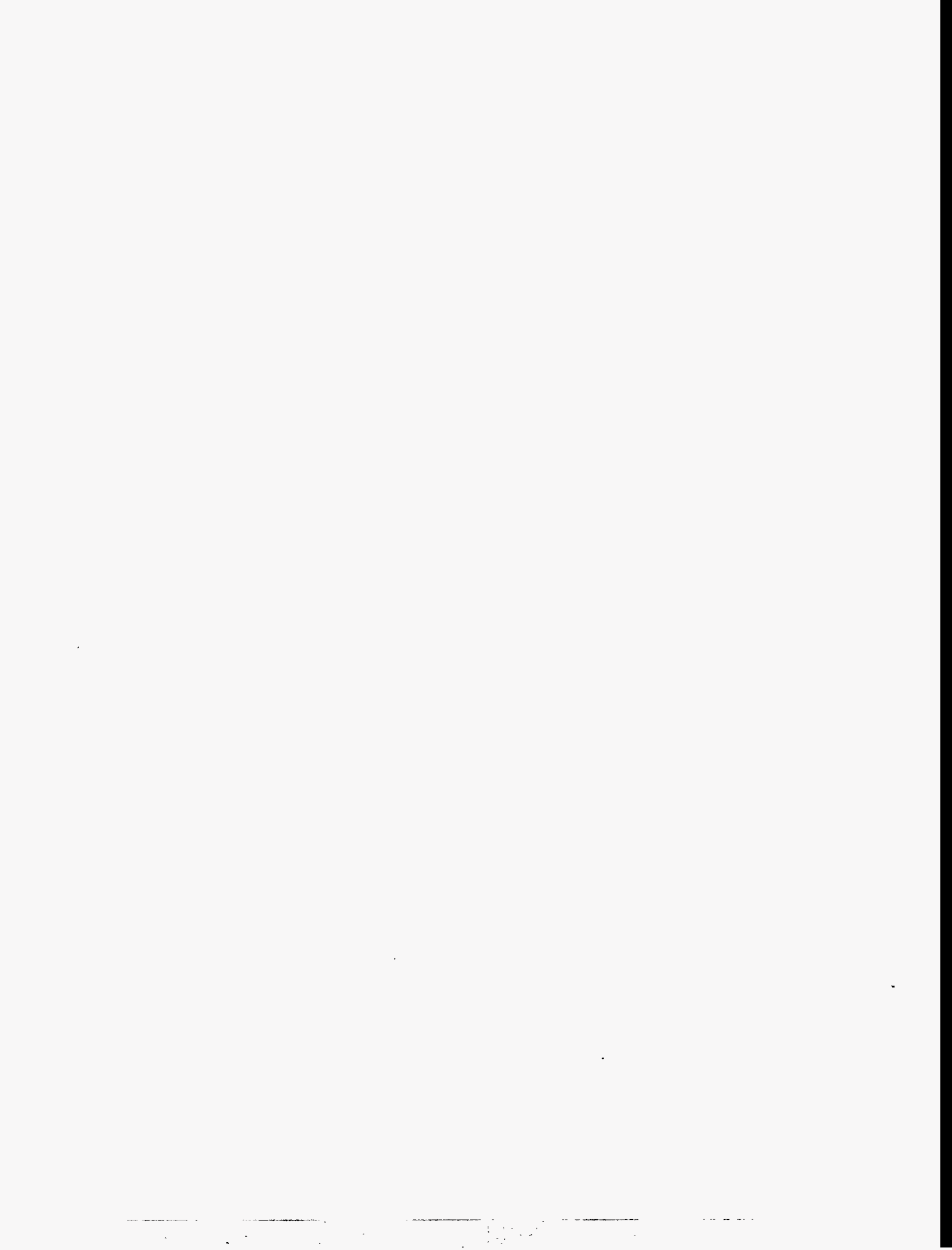

1. INTRODUCTION

The detection of trace quantities of targeted analyte species is a common analytical scenario often discussed in analogy with "finding a needle in a haystack". A particularly high profile application in the security arena is the detection of trace quantities of explosives as a means for indicating the possible presence of an explosive device. A major drawback to this approach is the lack of a direct relationship between the presence and quantity of an explosive material found in the air or on a surface, and the size or even presence of an explosive device nearby. The detection of a trace quantity of explosive simply indicates that an explosive device may be nearby. Likewise, the failure to detect traces of explosive does not necessarily lead to the conclusion that no explosive device is nearby. Nevertheless, there is a long history of use of trace detectors, most commonly in the form of trained dogs, for a wide range of applications in the security arena, including explosives detection.^{1,2} While there are a number of advantages to animal olfaction in security applications, there has been a longstanding interest in an instrumental approach for trace explosives detection both as a complement to animal olfaction and as a means for explosives detection in scenarios in which animal olfaction is either impractical or inappropriate.³

A trace detector must be sensitive, specific, and fast before it can be considered as a viable candidate in most explosives detection scenarios. It is also highly desirable that it be as small as possible, affordable, and easy to operate for use in the field. As a result of the many diverse constraints placed upon a trace chemical detector for field applications, a variety of instrumental approaches has been developed for trace detection of explosives, each with its own set of relative merits, including several based on mass spectrometry.^{1,2} We have approached this problem with tandem mass spectrometry,^{4,5} a technique widely recognized for its suitability to solve "needle in a haystack" problems. It is sensitive, extremely specific, and fast. In particular, we have based our approach on quadrupole ion trap tandem mass spectrometry⁶⁻¹⁰ coupled with atmospheric sampling glow discharge ionization¹¹ (ASGDI). Relative to most forms of mass spectrometry and tandem mass spectrometry, the ion trap has clear advantages in size and affordability. In addition, the ion trap is a remarkably powerful ion manipulation and mass analysis device. The capabilities of the glow discharge/ion trap combination have evolved over the past decade as the quadrupole ion trap has developed as an analytical tandem mass spectrometer. This report provides an overview of the current capabilities of the glow discharge/ion trap as a tool for the detection of trace quantities of explosives. A discussion of instrumental developments, anion formation (as it relates to ASGDI), tandem mass spectrometry, ion trap mass spectrometry of ions derived from ASGDI, and ion trap tandem mass spectrometry of explosives-derived anions is presented.

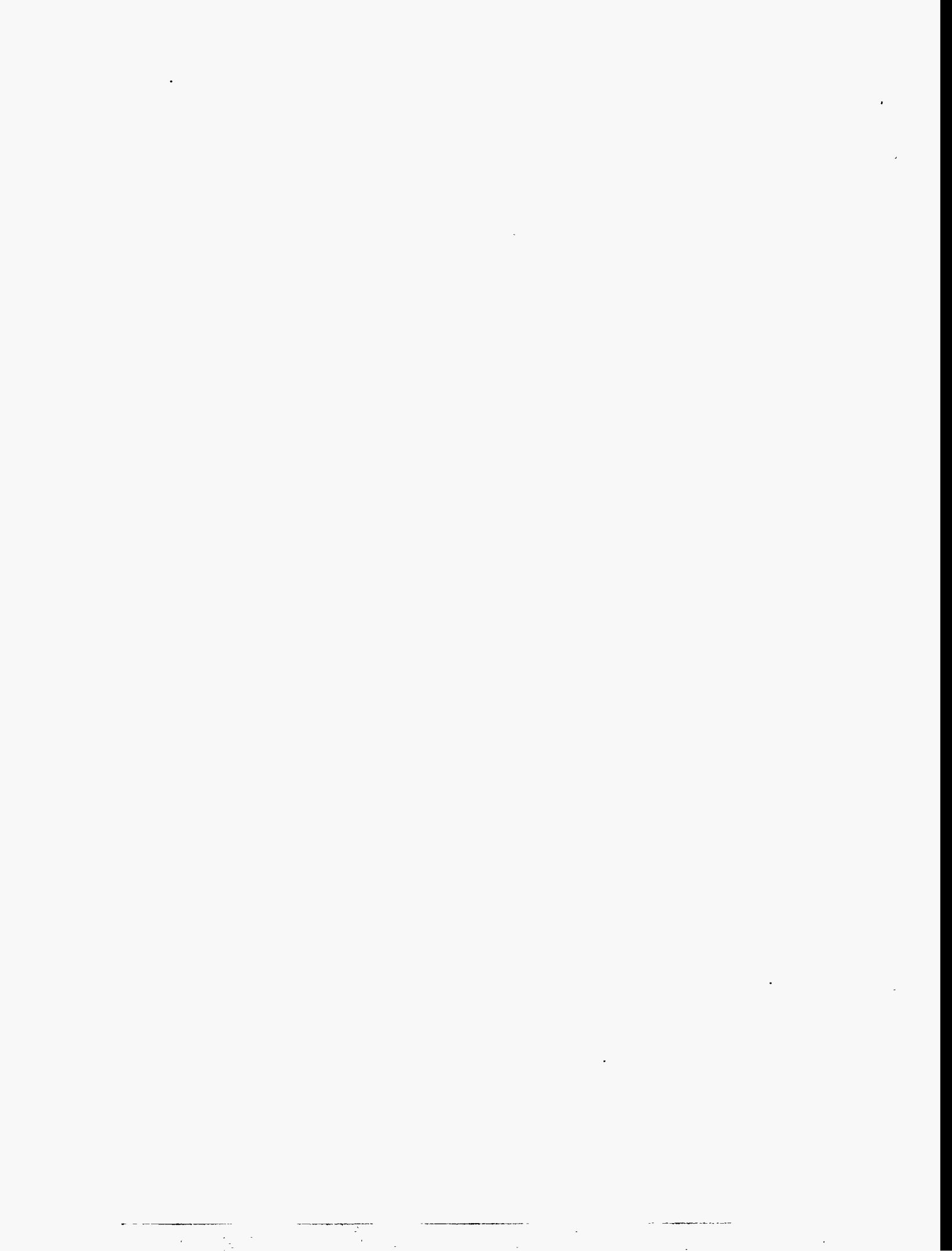

2. INSTRUMENTATION FOR ATMOSPHERIC SAMPLING GLOW DISCHARGE IONIZATION/ION TRAP MASS SPECTROMETRY

Most of the glow discharge/ion trap development work has been performed using the electronics, software, and ion trap analyzer of the Finnigan MAT Ion Trap Mass Spectrometer (ITMS[®]) (Finnigan MAT Corp., San Jose, CA). The ITMS vacuum housing was replaced with a 6 inch cube designed to accommodate 6 inch Conflat flanges. A feed-through flange was designed to support the ion trap electrodes, conversion dynode electron multiplier detector, and lenses used to focus ions into the ion trap. All electrical connections within the vacuum system, except for the radio-frequency (rf) drive voltage applied to the ring-electrode, are made via this flange. The rf connection is made via a separate feed-through flange mounted 90° with respect to the ion trap mounting flange. When the injection lens/ion trap/detector assembly is mounted in the 6 inch cube, the front of the first tubular element of the ion injection lens is situated several millimeters beyond the front face of the opposite side of the 6 inch cube. This allows the lens to extend into a recessed region of the atmospheric sampling glow discharge ionization source mounted on the opposite side of the 6 inch cube. The 6 inch cube is evacuated with a 350 L/s turbomolecular pump.

The ASGDI source mated with the ITMS system is housed within a 6 inch Conflat flange that has been milled out to allow for a discharge volume. Four ½ inch holes spaced 90° apart extend from the outer edge of the flange to allow for evacuation of the discharge volume. A Cajon adaptor is welded onto each of these holes to facilitate connection to a roughing pump. Two aperture plates complete the source. The inner aperture plate separates the discharge volume from the vacuum system of the ion trap and contains a 400 µm hole. The outer aperture plate separates atmosphere from the discharge region and contains a 200 µm hole. A cross-section schematic of the ASGDI source and the electrical elements of the ion trap assembly is shown in Figure 1. Note that the detector, a Galileo Model 4773, is modified by altering the angle of the conversion dynode from roughly 45°, relative to the incoming ion beam, to nearly 180°. This was done to reduce significant photon background arising from the discharge.

Table 1 lists the typical DC voltages applied to the relevant electrical elements along with typical operating pressures. These potentials are used to inject anions into the ion trap and to detect anions ejected during mass analysis. Lens 2 is composed of two half-plates. During the ion accumulation period, both half plates are held at +180 V while at all other times, one of the half plates is held at -180 V. This half plate is connected to the electron gate voltage supplied by the ITMS electronics thereby providing a convenient means for software control of the ion accumulation period. Note that a small positive DC voltage is sometimes applied to the

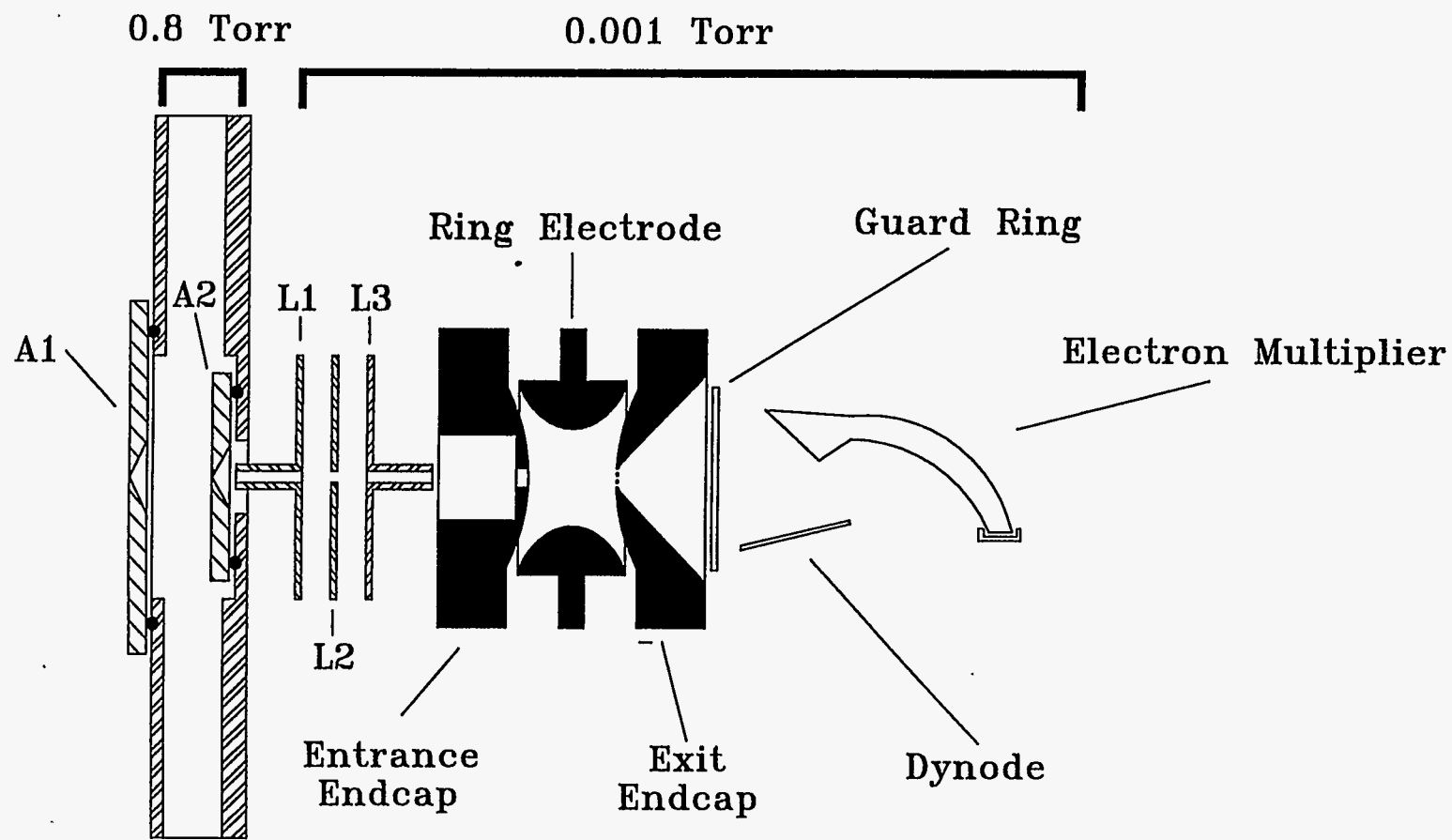

Figure 1. A side-view schematic of an ASGDI source interfaced with a Finnigan ITMS[®]. Operating characteristics of this instrument are listed in Table 1.

Table 1. Operating characteristics for anion analysis using the glow discharge/ion trap based on the Finnigan ITMS.

ASGDI source pressure	0.7-1.0 torr
Vacuum system pressure	1 x 10 ⁻⁴ torr (no helium) 1-1.5 x 10 ⁻³ (helium added)
Source sampling rate	3-5 mL/s
A1	-350-400 V
A2	0 V
discharge current	2.5-10 mA
L1	+10-30 V
L2	+180 V
L3	+150-300 V
Entrance end-cap	+0-2 V
Guard ring	+1500 V
Dynode	+3500 V
Electron multiplier	-1500-2200 V

entrance end-cap. This has sometimes been found to enhance ion injection efficiency^{12,13} from glow discharge sources. There is evidence that this effect is related to the degree of surface oxidation surrounding the entrance end-cap aperture.¹⁴ It is important to point out that a small permanent magnet located near the ASGDI source is often necessary for the observation of strong anion signals from the ion trap. The role of the magnet is believed to be prevention of fast electrons (> 10 eV) from being injected into the ion trap. Cations, formed within the trapping volume by electron bombardment, can neutralize the stored anions. Small permanent magnets have been observed to have no effect on negative ion mass spectra derived from ASGDI acquired with a quadrupole mass filter.

Recently, a Teledyne-Hitachi 3DQ quadrupole ion trap system (Teledyne Electronic Technologies, Mountain View, CA) has been modified for trace explosives detection. In this case, the 3DQ vacuum system was retained and an ASGDI source was designed to mate with the front flange of the 3DQ hardware. The ion injection lens stack is supported off of the ion source flange. The existing feed-throughs on the 3DQ vacuum system are used to apply the necessary voltages to the lens elements. The detector supplied with the system was replaced with a Galileo 4773 detector modified as described above to allow for anion detection. The major difference between the ITMS and 3DQ glow discharge systems lies in the pumping capacity of the vacuum hardware. The 3DQ vacuum system is evacuated with a 60 L/s turbomolecular pump and the ASGDI source attached to the 3DQ is pumped with a 5.2 L/s (free air displacement) roughing pump (Alcatel, Model 2012A). The ITMS system is evacuated with 350 L/s turbomolecular pump and the ASGDI source is evacuated with a 27 L/s roughing pump (Leybold, TRIVAC A, Model D60A). The ventilation rate of the ASGDI source on the ITMS, however, is limited by the conductance of the tubing and pump-out ports such that the sampling rates of the two ASGDI sources do not differ dramatically. The air sampling rate of the ASGDI/3DQ system is 1.5 mL/s (110 μ m aperture) as opposed to 5 mL/s for the ASGDI/ITMS system (200 μ m aperture). As discussed below, the performance characteristics of the two systems differ very little despite the significantly lower investment in vacuum pumps for the ASGDI/3DQ system. Machine drawings of many of the custom designed pieces of vacuum hardware for both the Finnigan and Teledyne systems are included in Appendices IV and V.

The central element of the ion injection lens of the modified 3DQ system, like that of the modified ITMS, is split into two half plates. This allows the electron gate potential to inject ions into the ion trap or to deflect them, as desired. However, an alternative approach to ion gating has also been used with the 3DQ system. The discharge itself has been pulsed such that the duration of the discharge defines the ion accumulation period. A pulse supplied by the 3DQ electronics, which is under software control, is used to trigger a variable length pulse generator (Berkeley Nucleonics Corp., Berkeley, CA, Model 8010) which, in turn, is used to gate a high voltage solid state pulser (Directed Energy Inc., Fort Collins, CO, Model GRX-1.5K-E). The output of the pulser is connected to aperture plate A1 (see Figure 1). The pulser acts as a fast switch which alternates between a voltage sufficient to strike a discharge (≈ 400 V) between the aperture plate (as normally provided by an ORTEC Oak Ridge, TN, Model 556 power supply) and ground. The pulsed discharge approach allows the potential applied to the central element of the ion injection lens to become a variable for optimizing the focus of the ion beam emanating from the glow discharge onto the ion trap entrance aperture. (The central element of the ion injection lens is fixed at 200 V when the ion trap electron gate of the ion trap electronics is used to gate ions.) Furthermore, the pulsed discharge reduces noise by eliminating background photons arising from the discharge, which are present during mass analysis when using a constant discharge source.

3. ATMOSPHERIC SAMPLING GLOW DISCHARGE FOR ANION FORMATION

In any application of mass spectrometry the choice of ionization method is of critical importance. Since matter comes in all forms (i.e., solid, liquid, and gas), and ranges from atoms to large biomolecules, a wide variety of ionization methods has been developed for mass spectrometry. For the detection of explosives vapors, gas-phase ionization techniques are the methods of choice. A variety of such methods has been applied to the analysis and detection of explosives vapors including electron ionization,¹⁵⁻¹⁸ chemical ionization,^{15,16,18} field ionization,¹⁹ atmospheric pressure ionization,²⁰⁻²² low pressure electron capture,²³⁻²⁵ and glow discharge ionization.^{11,26,27} Each method has its own set of characteristics relevant to the detection of explosives vapors. It is beyond the scope of this report to discuss the relative merits of each of the possible approaches to ionizing trace explosives vapors in air. Rather, the characteristics of atmospheric sampling glow discharge ionization are discussed, with occasional reference to how they compare with those of other ionization methods. In general, ASGDI is a simple and rugged means for ionizing organic species in air for either the positive or negative ionization modes. The response is essentially instantaneous, with very little memory effect arising from analyte species that enter the ionization region. That is, chemical noise arising from analyte deposited within the ionization volume, which ordinarily requires source cleaning, poses few problems even after many months of nearly continuous operation. However, surfaces leading up to the sampling aperture can easily become contaminated giving rise to the major source of any memory effects. Work at Oak Ridge National Laboratory (ORNL) has shown the ASGDI source to be useful for a variety of applications in trace vapors analysis.^{11,28} It is particularly useful for applications in which negative ion analysis is appropriate, as it is with high explosives.

The explosives vapor detection problem requires the formation of ions characteristic of explosives when they are present in a complex mixture. The mixture could be air that is sampled directly into the detector, or a mixture resulting from a preconcentration step. The relative concentrations of mixture components, particularly at the parts per million level and below, can vary widely with both location and time. Since it is desirable to detect explosives vapors present at parts per trillion levels and below, an extremely selective ionization method is desirable. The analysis of negative ions in the explosives detection application is employed because, unlike most compounds in nature, high explosives such as the nitroaromatics, the nitrate esters, and the heterocyclic nitramines, readily form anions. Indeed, several other approaches to explosives vapor detection take advantage of this characteristic. These include ion mobility spectrometry (IMS),^{29,30} atmospheric pressure ionization mass spectrometry (APIMS),^{20-22,30,31} and gas chromatography/electron capture detection (GC/ECD).³³ There are, however, differences between the conditions used in the ASGDI source and those used in the

other devices that have important ramifications for the ions that are observed and the susceptibility for interferences.

The conditions used in the ASGDI source operated near 1 Torr are significantly different from those used for ionization techniques at atmospheric pressure. These differences and their effects can be appreciated by considering simple pseudo-first order kinetics. Consider the ion/molecule reaction

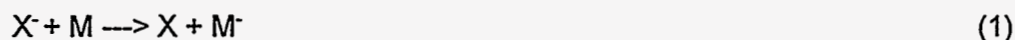

where analyte species M is present at a constant concentration throughout the period that the reaction can proceed. The number of X^- reagent ions observed after some reaction time t is given by

$$[X^-] = [X^-]_0 e^{-k[M]t} \quad (2)$$

and the number of M^- ions that are formed is given by

$$[M^-] = [X^-]_0 (1 - e^{-k[M]t}) \quad (3)$$

where $[X^-]_0$ is the number of X^- ions present at $t=0$, k is the rate constant for the ion/molecule reaction, and $[M]$ is the number density of M. Under API conditions, flow rates are typically on the order of 1 mL/s giving reaction (residence) times on the order of 1 ms. Rate constants for fast ion/molecule reactions are on the order of 10^{-9} cm³/molec-s. Rate constants for electron capture reactions, i.e.,

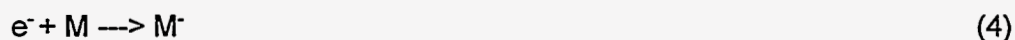

can be as high as 10^{-7} cm³/molec-s³⁴ (100 times greater). Electrons are therefore quickly captured in the presence of an electronegative reagent gas thereby forming anions. [The number density of electronegative gases (primarily O₂) in air at atmospheric pressure and room temperature is $\approx 4 \times 10^{18}$ cm⁻³.] Provided the rate constants are not too low, both the forward and reverse reactions for an ion/molecule reaction can occur a sufficient number of times to give an equilibrium distribution of reactants and products. The number densities of the reactants and the long reaction time result in a distribution of ion/molecule reaction product ions that tend to reflect thermodynamic equilibrium. Furthermore, number densities are high enough for third-body collisions to occur resulting in the observation of stable adduct ions as indicated below:

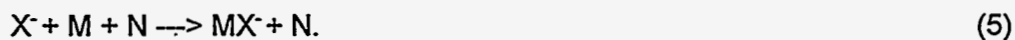

The likelihood for observation of cluster ions in APIMS is further enhanced by cooling associated with the expansion of the plasma from atmosphere into the high vacuum. For this reason, ion declustering methods are typically employed.

In the ASGDI source, number densities are roughly three orders of magnitude lower than in API devices. Furthermore, the residence time of the molecules in the ionization region

is typically less than 1 ms (as determined by the ventilation rate). Given the shorter residence times and lower number densities than those relevant to API, ion/molecule reactions can only proceed to an appreciable extent if, assuming a rate constant of 10^{-9} cm³/molec-s, the neutral number density is greater than about 20 parts per billion. Product ions formed via ion/molecule reactions begin to rival the intensities of the background "reagent ions" in the source ($\approx 10\%$ of the total ion current) only when the concentration of the analyte is at least 20 parts per million. Therefore, for species present at levels less than 1 ppm, the majority of negative ions come from electron capture rather than from ion/molecule reactions.

These differences in operating conditions have several significant effects on the data acquired with ASGDI and API ion sources. The first is that the ions characteristic of the explosive may be different. For API sources it is common to observe $(M-H)^-$ and $(M+X)^-$ ions whereas with the ASGDI source it is common to observe M^- and/or fragment ions. The second effect manifests itself in the susceptibility for interferences. There are typically two types of interferences with most analytical techniques. One occurs when some species other than the analyte produces a signal that is indistinguishable from that of the analyte. We use tandem mass spectrometry to minimize this type of interference. The second type occurs when some species alters the signal from the analyte either by suppressing its intensity or by moving it to another part of the spectrum where it is not recognized. This is often referred to as a "matrix effect". An example of the latter would occur when some background species enters the API ionization region in sufficient quantity to change the ion/molecule reaction chemistry, thus leading to a change in the identity of the analyte-related ions. This may involve a change in the identity of the explosive related ion from, for example, $(M+X)^-$ to $(M+Y)^-$. In fact, this effect has been used to advantage in at least one approach to ionization of explosives by API.³⁵ Since ion/molecule reaction chemistry plays a very small role for low concentration analytes in the ASGDI source, the anions associated with the explosives do not change position on the mass scale despite the presence of relatively large doses of compounds that alter ion/molecule reaction chemistry. The ASGDI source is vulnerable to this type of interference only insofar as it affects the number of electrons and the distribution of their kinetic energies. An extreme example occurs when a heavy dose (> 10 parts per thousand) of a halocarbon is used to extinguish the discharge. Our experience with halocarbons at levels insufficient to extinguish the discharge but sufficient to completely alter the distribution of background ions in the ion source is a diminution in signal due to explosives of a factor of 2-3 but no change in the identity of the ions. The ASGDI source, therefore, is relatively immune to interferences of the second type.

A relatively high number density of electrons present in the glow discharge ($\approx 10^{10}$ cm⁻³) apparently gives rise to good linearity of response for ions derived from electron capture over a concentration range of 10^{-12} - 10^{-6} . Such a response was observed for 2,4,6-trinitrotoluene using an ASGDI source coupled with a quadrupole mass filter.¹¹ A much more restricted dynamic range ($\approx 10^2$) is typically observed in most API systems due to the limited numbers of reagent anions present.

Clustering is much less likely in ASGDI than in API for some of the reasons just mentioned. Clustering of analyte ions with analyte molecules is unlikely due both to the short residence time and the low concentration levels of analyte. Clustering with background species, such as water, is also rarely observed due to the fact that the initial expansion from

atmosphere into vacuum occurs prior to ionization rather than after ionization as in API. Therefore, the ion-dipole and ion-induced dipole attraction that promotes clustering under expansion conditions is not operative in ASGDI. The second expansion from the ASGDI source into the mass spectrometer region is too dilute for significant clustering.

Ionization methods in which low neutral number densities are present, such as low energy electron capture at $<10^{-5}$ torr,²³⁻²⁵ lie at the opposite extreme. The spectra derived from electron capture at low pressures often differ significantly from those observed using ASGDI. As a rule, much more extensive fragmentation is observed using low pressure electron capture methods than is observed using ASGDI. The collision frequency in the ASGDI source is on the order of 10^7 s⁻¹ which, depending upon the inherent anion lifetime following electron capture, can allow for collisional cooling of excited anions.

The characteristics of ASGDI that make this ionization technique attractive for real-time explosives detection include: (1) A simple and rugged design which provides a direct interface between atmosphere and the vacuum system of the mass spectrometer. The ASGDI has no filaments or discharge needles to replace and can be operated continuously for months without maintenance. Despite rather extensive ion burning, source cleaning is not important. Some of the ion sources at ORNL have been operated over the course of several years without cleaning and show no loss in performance. (2) The source has a relatively high throughput. The air sampling rate is 1-5 mL/s, which is relatively high for a vapor detector. This makes for rapid response and rapid pump-out of analyte. Memory effects arise almost exclusively from adhesion on surfaces leading into the ion source, as opposed to adhesion on surfaces within the ionization volume. (3) Ionization conditions are such that there are significant differences between API and low pressure electron capture in terms of the types of ions observed and the susceptibility to matrix effects.

Table 2 summarizes the negative ion ASGDI mass spectra of a variety of species of potential interest in an explosives detection scenario. These species include many of the commonly encountered organic high explosives with examples from compound classes such as nitroaromatics, heterocyclic nitramines, and nitrate esters. Several inorganic species, such as ammonium nitrate and sulfur (a major constituent of black powder), are also included.

Table 2. Major ions in the negative ion ASGDI mass spectra of explosives and related compounds

<u>Compound</u>	<u>Major ion(s)</u>	<u>m/z</u>
2,4,6-trinitrophenol (picric acid)	M ⁻	229
dinitrophenols (DNPs)	M ⁻	184
mononitrophenols (MNPs)	M ⁻	139
2,4,6-trinitrotoluene (TNT)	M ⁻	227
dinitrotoluenes (DNTs)	M ⁻	182
mononitrotoluenes (MNTs)	M ⁻	137
mononitroanilines (MNAs)	M ⁻	138
2,4-dinitroaniline	M ⁻	183
dinitrobenzenes (DNBs)	M ⁻	168
nitrobenzene	M ⁻	123
2,4-dinitrophenylhydrazine	(M-NO) ⁻	168
hexanitrostilbene	M ⁻	450
2,4,6-trinitrophenylmethylnitramine (tetryl)	(M-NO ₂) ⁻	241
ethylene glycol dinitrate (EGDN)	NO ₃ ⁻	62
nitroglycerine (NG)	NO ₃ ⁻	62
pentaerythritol tetranitrate (PETN)	(M-CH ₂ ONO ₂) ⁻ NO ₃ ⁻	240 62
cyclotrimethylene trinitramine (RDX)	(M-NO ₂) ⁻ (M-NO ₂ ,HNO ₂) ⁻ (M-NO ₂ ,CH ₂ NNO ₂) ⁻	176 129 102
cyclotetramethylene tetranitramine (HMX)	(M-NO ₂) ⁻ (M-NO ₂ ,HNO ₂) ⁻ (M-NO ₂ ,CH ₂ NNO ₂) ⁻	250 203 176
Black powder (sulfur)	S ₂ ⁻ , S ₃ ⁻ , S ₄ ⁻	64, 96, 128
Ammonium nitrate	NO ₂ ⁻	46
2,3-dimethyl-2,3-dinitrobutane	NO ₂ ⁻	46

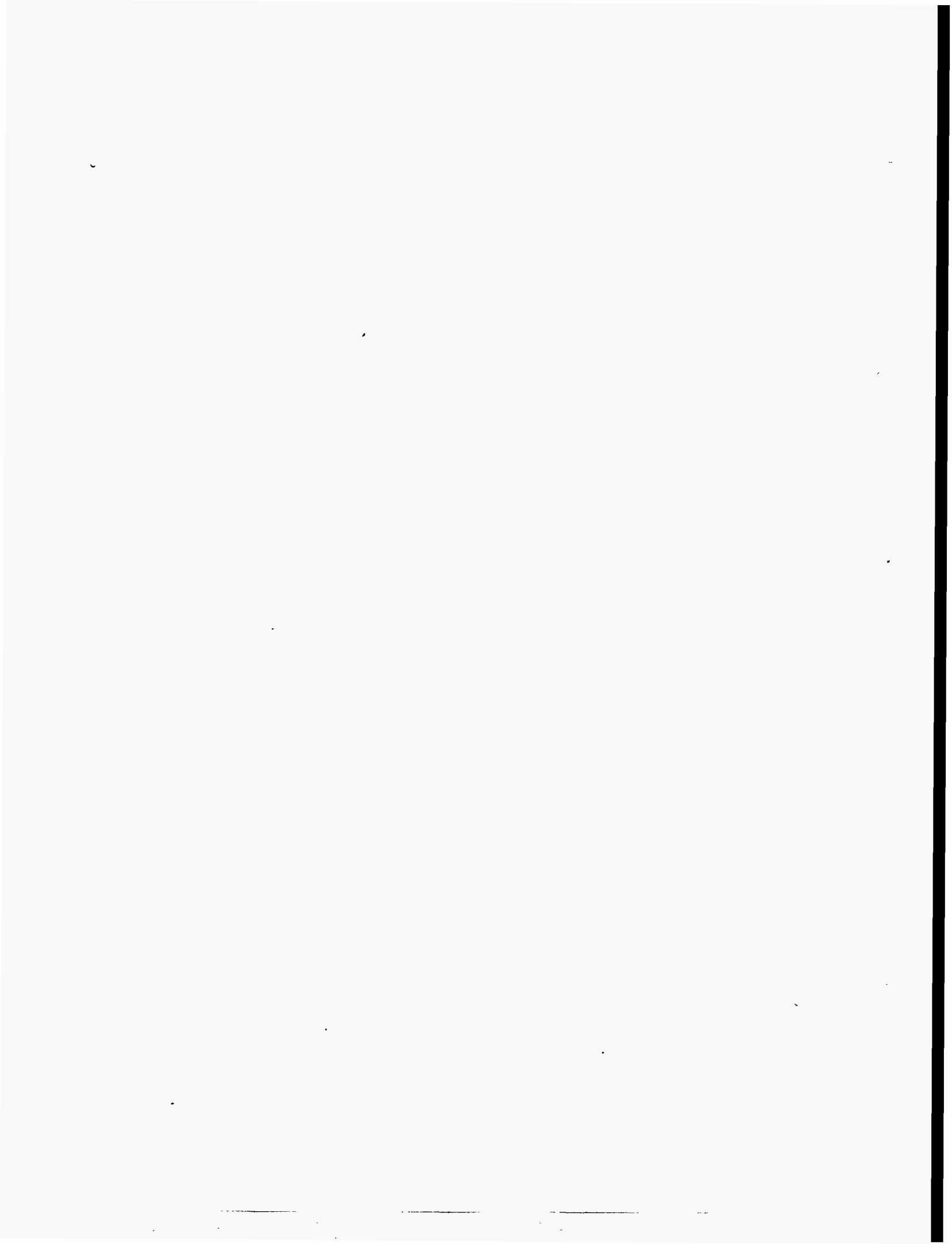

4. TANDEM MASS SPECTROMETRY

Single stage mass spectrometry is one of the most sensitive and specific instrumental methods available to identify organic compounds. However, it cannot perform trace analysis of complex mixtures without an extremely selective ionization method and/or some prior separation step. The most common technique involving mass spectrometry for the analysis of mixtures of volatile compounds is the combination of gas chromatography with mass spectrometry (GC/MS). Historically, gas chromatography has not played an important role in real-time mixture analysis due to the relatively long times required for separation. (Recent developments in fast GC have made its use in explosives vapor detection a viable part of the analysis.) An alternative to GC/MS in targeted compound analysis is to replace the GC with a mass spectrometer to perform mass spectrometry/mass spectrometry (MS/MS), or tandem mass spectrometry.^{4,5} Since the mass spectrometer selects according to mass/charge, mixture components can be analyzed in any sequence, which is an advantage when only a few components are of interest. Furthermore, the first stage mass-selection step can take place on the time-frame of microseconds to milliseconds, depending on the mass spectrometry technology (see below). This time-frame obviously compares favorably with chromatography. A schematic comparison of GC/MS with MS/MS is shown in Figure 2 assuming an ionization method that produces positive ions.

A chemical reaction resulting in a change in mass/charge must occur between stages of mass spectrometry in an MS/MS experiment for the second stage of mass analysis to provide new information. The most common reaction is fragmentation shown generically below for a molecular anion:

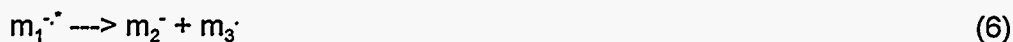

where $m_1^{\cdot-}$ represents an excited molecular anion and $m_2^{\cdot-}$ and m_3^{\cdot} represent the charged and neutral products of a dissociation reaction, respectively. The dissociation of a so-called "parent" ion into product ions and neutrals is ordinarily induced via one or more energetic collisions of the parent ions with neutral species admitted into the instrument to serve as collision partners. This process involving the production of excited parent ions which subsequently dissociate into products is commonly referred to as collision-induced dissociation (CID).³⁶⁻³⁹ Therefore, the identification of a targeted compound in a typical MS/MS experiment is based on the mass/charge ratios of the parent and product ions.

Tandem mass spectrometry has a variety of important applications. Among the most widely recognized is direct targeted compound analysis. Explosives vapor detection is, of course, a targeted compound analysis problem. The MS/MS experiment for explosives

Schematic Comparison of MS/MS with GC/MS

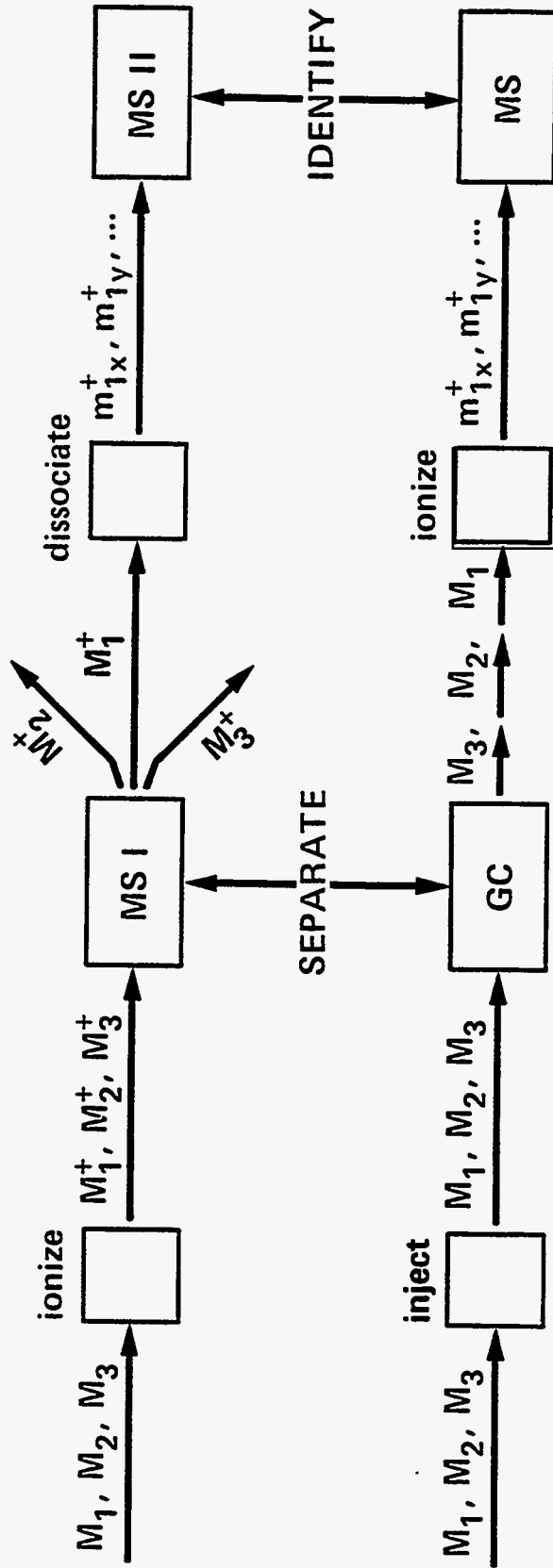

Figure 2. Schematic comparison of GC/MS with MS/MS.

detection is shown schematically in Figure 3 as proceeding from left to right. Air is drawn into the glow discharge source where explosives vapors are converted to negative ions. The anions that issue from the ASGDI source are subjected to a stage of mass analysis. If ions of mass/charge corresponding to those expected for a targeted explosive are present, they are subjected to collisional activation. The product ions formed from CID are then subjected to a second stage of mass analysis. A molecule to be identified as an explosive must pass three tests. First, it must form a negative ion. That is, it must be ionized by the ASGDI in the selective negative ionization mode. Second, it must form an ion of mass/charge expected for a targeted explosive. And third, it must form the product ion(s) expected for the explosive ion of the selected parent ion mass/charge. These three tests constitute an extremely specific identification procedure designed to minimize false alarms.

It is difficult to predict *a priori* the false alarm rate for any of the current explosives detectors in a real-world scenario since the complexity of the mixtures to be confronted is poorly characterized at best. However, it is possible to compare the techniques on the basis of the number of resolution elements in the analysis.⁴⁰ The number of resolution elements determines, in part, the informing power of an analytical technique. Informing power correlates with specificity. As a rule, as a mixture becomes more complex, greater informing power is required to distinguish between mixture components. A typical IMS spectrum is ≈ 20 ms wide and a typical peak width at half height is 1 ms. There are, therefore, ≈ 20 resolution elements for the ion mobility spectrometer. The overall specificity of the analysis relies heavily on the selectivity afforded by negative ion API. Similarly, for GC/ECD, the resolving power of the GC analysis is determined by the chromatographic resolution. For most gas chromatographs used in explosives detection there are, at best, a few hundred resolution elements in the typical chromatogram. The overall specificity of the analysis is enhanced by ECD. In MS/MS, the number of resolution elements is the product of the resolution elements of each stage of MS. For most tandem mass spectrometers based on quadrupole technology, the resolution of each stage of MS is typically 1000 (unit mass resolution throughout the mass range). The explosives ions generally fall below m/z 300 so that, realistically, there are about 300 useful resolution elements/stage of MS. The number of resolution elements for MS/MS is therefore $\approx 90,000$. This number may be increased if additional resolution elements are added by varying the parameters that affect the reaction between stages of MS.⁴⁰ The specificity of the overall analysis is, of course, enhanced by analyzing negative ions. Informing power is also determined by the dynamic range of the analysis⁴⁰ which further increases the informing power of MS/MS over the IMS and ECD. The informing power of MS/MS is therefore several orders of magnitude greater than any of the other commonly employed vapor detectors.

The sensitivity of an explosives detector employing MS/MS is determined in part by the throughput of the MS/MS instrument. This involves the efficiency of the first stage of MS, the efficiency with which fragment ions are produced from the parent ions, the efficiency of the second stage of MS, and the detection efficiency. These numbers are determined by the mass analyzers, ion optics, and the way in which CID is effected. There has been a wide variety of instrumental approaches to MS/MS. Each has its own set of performance characteristics and many have unique advantages for particular applications. There is no "best" instrumental approach for all MS/MS experiments. However, the number of approaches suitable for fieldable explosives detection is relatively limited. A short discussion of the various approaches to MS/MS is given in the following sections with particular emphasis on the desirable qualities for a

THREE-STEP PROCESS CAN SELECT AND IDENTIFY TRACES OF TARGETED COMPOUNDS

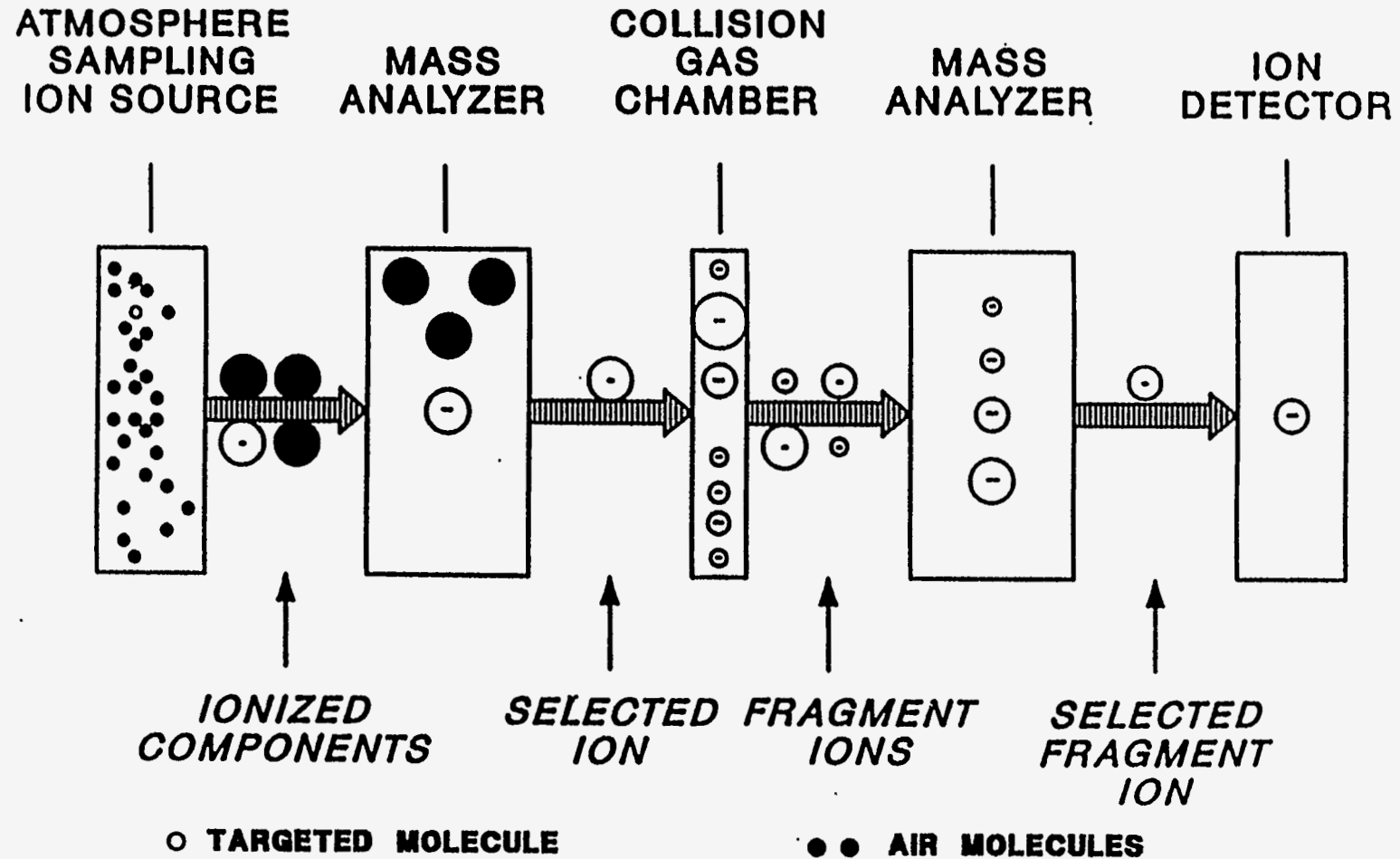

Figure 3. Schematic representation of the ASGDI MS/MS experiment for explosives detection.

tandem mass spectrometer in the explosives detection scenario. These approaches can be conveniently classified as either beam-type technologies or ion trapping technologies.

4.1. BEAM-TYPE TECHNOLOGIES

The term "beam-type" instrument refers to a mass spectrometer in which ions formed in an ion source are extracted and accelerated, usually continuously thereby forming an ion beam, through static magnetic and electric fields or through electrodynamic fields wherein the trajectories of the ions are altered in a mass/charge dependent fashion. The mass/charge discrimination, therefore, occurs in space. In the case of a magnetic sector mass spectrometer, for example, the radii of deflection of ions in a monoenergetic ion beam are determined by the momentum/charge ratios of the ions. A slit or aperture at the focal point of the magnetic sector allows a limited range of momentum/charge ratios to pass to a collision region, for example. In the case of a quadrupole mass filter, the radio-frequency and fixed voltages applied to the four rods comprising the device can be established to provide for high pass filtering in one dimension and low pass filtering in the other such that only a limited range of mass/charge ratios can pass through the device. In the case of the time-of-flight mass spectrometer, a monoenergetic "packet" of ions is separated according to transit times. The term "beam-type" tandem mass spectrometer is intended to imply further that the stages of mass spectrometry and collision-induced dissociation occur in discrete regions of the spectrometer.^{4,5}

Some of the more commonly employed beam-type tandem mass spectrometers are shown schematically in Figure 4 where S is the ion source, C is a collision cell, D is a detector, B is a magnetic sector, E is an electrostatic analyzer, and Q is a quadrupole mass filter. The first analytical tandem mass spectrometers were two sector instruments of either "forward" geometry (EB) or "reversed" (BE) geometry. In the former, CID is effected between the ion source and the electrostatic analyzer and product ions are analyzed by scanning the electric and magnetic fields simultaneously and at a fixed ratio. In the latter, CID can also be effected between the ion source and the first sector but more usually is effected between sectors. In the latter case, product ions are analyzed by scanning the electric sector. More elaborate multi-sector instruments have since been constructed primarily for research purposes, as opposed to routine analytical research.

The multiple quadrupole tandem mass spectrometers were introduced primarily for analytical applications.^{41,42} There are many important distinctions between the multi-sector and multi-quadrupole systems. A full discussion of these is beyond the scope of this overview. However, a few important distinctions are that quadrupole mass filters are readily programmable, mass resolution/transmission is variable via software over a range, and they lend themselves much more readily to field transportability. Therefore, for the reasons of size, weight, and cost alone, multiple quadrupole instruments are the most appropriate of the commercially available beam-type tandem mass spectrometers to consider for explosives detection. It is important to note that while commercial instruments are often referred to as "triple quadrupole mass spectrometers", only the first and third quadrupoles are used as mass analyzers. The central quadrupole is operated in the high pass filter (non-analyzing) mode. In fact, in many of the modern "triple quadrupole" instruments, the collision cell is actually an octapole. This is the case in the Finnigan TSQ700, the instrument modified for explosives detection as part of this interagency agreement.

INDIVIDUAL ANALYZERS CAN BE COUPLED SEVERAL WAYS FOR MS/MS

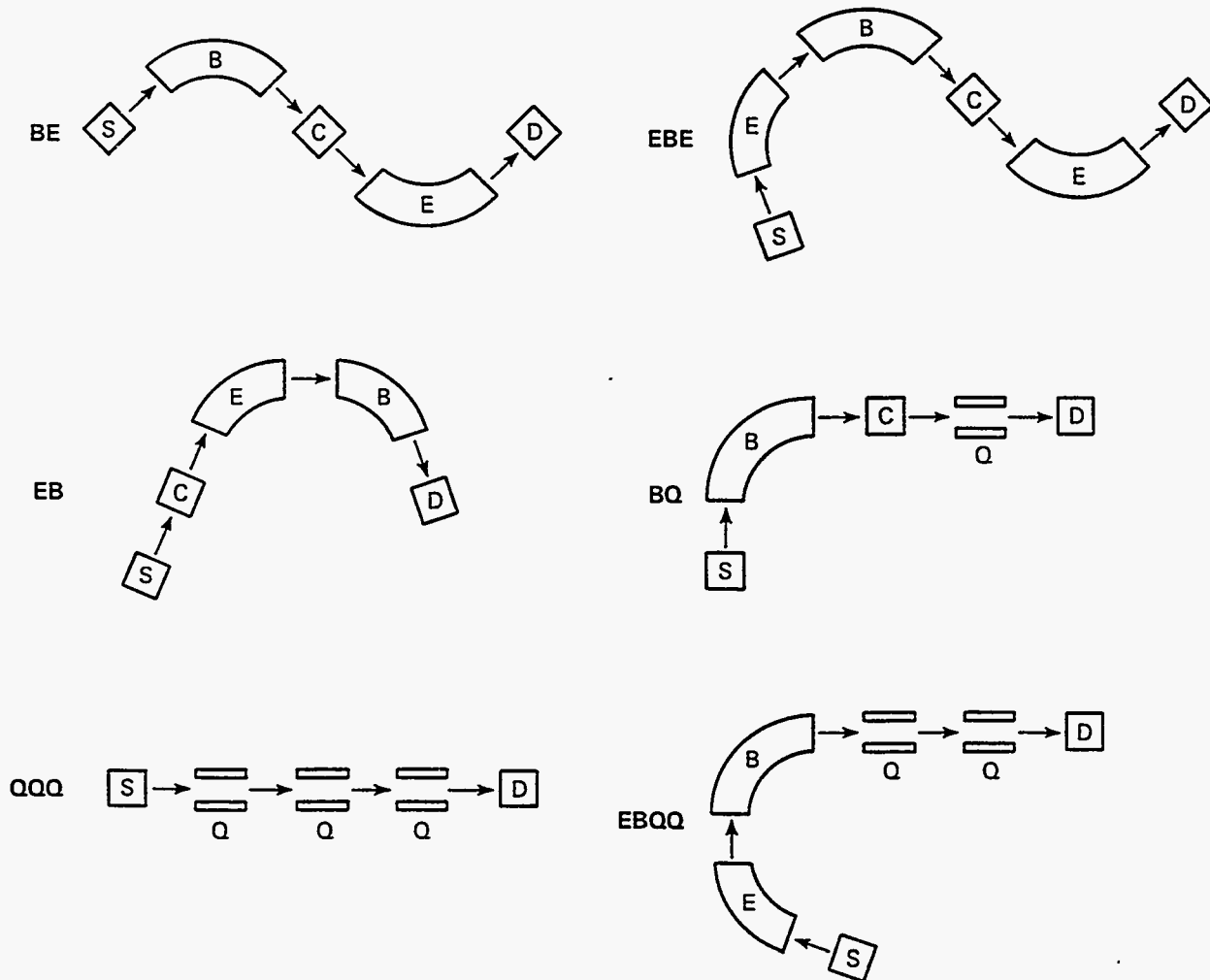

Figure 4. Some common MS/MS instrumental configurations.

Figure 4 also shows several instrument geometries that combine sectors and quadrupoles. These instruments are referred to collectively as "hybrid" mass spectrometers.⁴³⁻⁴⁵ These combinations are not inherently compatible as are the EB and BE geometries because quadrupoles operate best on ions with kinetic energies of tens of electronvolts at most, whereas sectors typically operate on ions with kiloelectronvolt kinetic energies. Therefore, one or more acceleration/deceleration steps must be effected in hybrids. Nevertheless, the combined strengths of these analyzers in a single instrument provides for unique research capabilities. However, from the point of view of explosives detection, hybrids have not been pursued for the same reasons that multi-sector instruments have not.

For the purpose of comparing and contrasting beam-type tandem mass spectrometers with trapping instruments described in the next section, a number of characteristics are listed here which apply primarily to the multiple quadrupole instruments. As discussed further in this report, beam-type and trapping technologies each enjoy advantages as the tandem mass spectrometer for explosives detection. However, since the beginning of this project, the rapid development of the quadrupole ion trap has shifted the balance strongly in favor of the trapping technology for explosives detection in the field. Important characteristics of beam-type technologies relevant to this discussion include:

- **Sensitivity** - While sub-picogram detection limits for explosives can be readily achieved in the MS mode in the absence of an isobaric interference, such low detection limits are challenging in the MS/MS mode due to transmission losses. Beam-type instruments usually provide many opportunities for ion losses during the passage of ions from the ion source to the detector. Fringing fields at the entrance and exit of each multipole can lead to ion loss, for example. There is also the usual compromise between resolution and transmission with the mass analyzers. Scattering of parent ions and product ions in the collision region can lead to significant losses as well. Indeed, the MS/MS efficiency, defined as the number of product ions measured in the MS/MS experiment divided by the number of parent ions measured prior to admitting the collision gas, is typically a few percent at best. Therefore, there is a significant cost in analytical signal in going from MS to MS/MS. (However, this is sometimes more than offset by the reduction in chemical noise arising from isobaric interferences.)
- **Specificity** - As mentioned above, specificity is determined by the number of non-redundant resolution elements in the analysis. The mass resolving power of each mass analyzer can easily be 1000 with good transmission. Furthermore, the MS/MS spectrum of a polyatomic ion is often highly dependent upon collision energy and target gas pressure. This dependence can be used to provide more informing power if needed. From our experience, the specificity of the triple quadrupole instrument is sufficiently high without recourse to collision energy-resolved analysis. We have yet to find any interferences that might lead to false alarms that cannot be avoided with the standard MS/MS procedure.
- **Speed** - Ion flight times are on the order of tens of microseconds. For healthy signals, therefore, the response is essentially instantaneous. Even in cases

where signal averaging can improve detectability, the mass spectrometer analysis time will be short relative to sampling and preconcentration steps.

- **Size** - Triple quadrupole instruments have not generally been engineered for field use although there is substantial room for miniaturization. However, the extensive pumping required for maintaining the analyzer quadrupoles at less than 10^{-5} Torr while the collision region is held at 1-5 mTorr remains a limiting factor in size and weight considerations.
- **Cost** - Commercial triple quadrupole systems typically cost over \$300K. A system designed specifically for explosives detection might be made for less but probably not without a large market. Power supplies for three multipoles are required, machining for high performance quadrupoles is demanding, and pumping is extensive. These factors make the prospects for a low cost (<\$100K) explosives detector seem remote considering the market size.
- **Dynamic range** - Dynamic range refers to the range of analyte quantity or concentration over which the analytical signal is linear. The dynamic range of a mass filter is roughly 10^8 . We have observed the dynamic range of a quadrupole system coupled with an ASGDI source to be at least 10^5 - 10^6 . Dynamic range is a strength of beam-type technologies because ion-ion interactions that can affect linearity are not important at the beam currents typically created by the ASGDI source or most other ion sources used in analytical chemistry.
- **Scan Flexibility** - The ready software control of the multiple quadrupole instrument and the nature of the beam-type experiment allow for a variety of different scanning modes for screening. The conventional MS/MS experiment, the product ion scan, is but one. Others include the parent ion scan, the neutral loss scan, and the targeted product scan.⁴⁶ The latter is discussed further in a later section.

4.2. TRAPPING TECHNOLOGIES

Several instrumental approaches to trapping charged particles and ions have been developed for research in physics and chemistry. Instruments used for analytical chemistry and which have been demonstrated to be capable of performing multiple stages of mass spectrometry include the ion cyclotron resonance (ICR) mass spectrometer⁴⁷ and the ion trap mass spectrometer.⁴⁸ The former is based on a static magnetic field and a parallel static electric field. The detection technique typically employed with commercial versions of the ICR involves image current measurement of all ions simultaneously and Fourier transformation of the time domain image current signal into the frequency domain. These instruments are usually referred to as Fourier transform mass spectrometers (FTMS).⁴⁹⁻⁵³ The FTMS technology has provided the highest mass resolving powers of any form of mass spectrometry. It is finding increasingly wide application in high performance mass spectrometry research and development. However, commercial systems employ relatively large superconducting magnets and must operate at low pressures for high resolution. Little effort has thus far been expended

in making fieldable FTMS instrumentation although such a development is not precluded at some sacrifice in performance.

In contrast to the development of FTMS, the analytical development of the quadrupole ion trap, or Paul trap,⁶⁻¹⁰ has primarily focussed on analytical applications requiring moderate resolving powers and those in which relatively high background pressures exist. Work has proceeded at ORNL for several years in developing the combination of ASGDI with a quadrupole ion trap for explosives vapor detection. Advances in this area now lead us to believe that this form of ion trapping technology should be given serious consideration for real-world security applications. For this reason, this form of ion trapping mass spectrometer is discussed at more length below and elsewhere in this report.

The quadrupole ion trap employs three electrodes as shown in the photograph of Figure 5. Two end-cap electrodes sandwich a ring electrode. The position coordinates in the ion trap can be described by the cartesian coordinates x , y , and z . However, due to the symmetry around the ring electrode, it is convenient to indicate the x and y coordinates by r , the radial coordinate, where $r = (x^2 + y^2)^{1/2}$. By convention, z is referred to as the axial coordinate. Note that the holes in the end-caps allow for ions to enter or exit the ion trap. The end-caps are ordinarily held at ground potential while a radio-frequency (rf) signal is applied to the ring electrode. The hyperbolic shapes of the electrodes result in a quadrupole potential within the ion trap cavity. A positive voltage on the ring electrode attracts negative ions and repels positive ions whereas a negative voltage on the ring electrode does just the opposite. The electric fields experienced by an ion for a large positive voltage and for a large negative voltage are illustrated in Figure 6. Note that for any non-zero voltage applied to the ring electrode, an ion finds itself in a potential well in one dimension and on a potential hill in the other. The key to trapping the ion is to vary the potential on the ring electrode at a frequency sufficient to prevent the ion from experiencing a repulsive field long enough to exit the ion trap. The application of a sine wave to the ring electrode creates the effect of flipping the saddle-shaped fields of Figure 6 back and forth to hold ions in the middle of the saddle. Ion storage as well as capture of injected ions is facilitated by adding a light background gas, such as helium, to remove kinetic energy from the ions without scattering them away from the center of the ion trap.

Trapped ions can be mass-analyzed in a variety of ways. The most commonly employed methods involve ejecting ions from the ion trap and into an externally-mounted detector in a mass-dependent fashion. The so-called mass-selective instability scan introduced by Stafford et al.,^{54,55} for example, involves scanning the amplitude of the rf signal applied to the ring electrode causing ions to achieve unstable trajectories in the axial dimension sequentially from low mass to high mass. A variation on this approach is the "resonance ejection" scan.⁹ For a given ring electrode rf amplitude and frequency, ions of each mass/charge have characteristic frequencies in the axial and radial dimensions. By scanning the ring electrode amplitude (or frequency) ions can be brought into resonance in the axial dimension with an alternating voltage applied to the end-caps. The application of a sinusoidal signal to the end-caps while the normal trapping rf signal is applied to the ring electrode is shown schematically in Figure 7. As the ions come into resonance they may absorb sufficient power to be ejected from the ion trap and into an external detector.



Figure 5. Photograph of the quadrupole ion trap assembly; two endcap electrodes and a ring electrode.

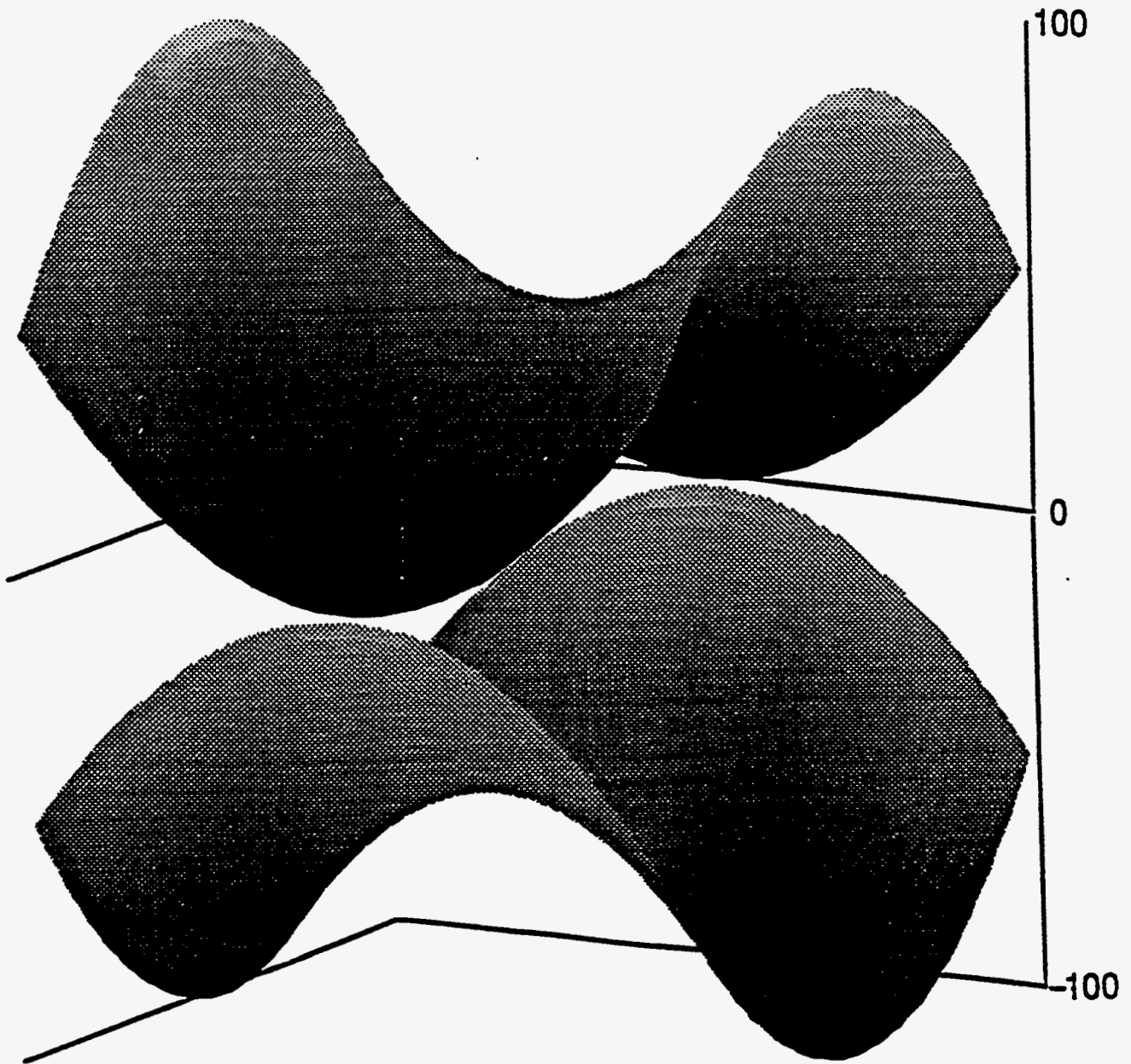

Figure 6. Schematic representation of the electric fields experienced by an ion for a large positive voltage and for a large negative voltage.

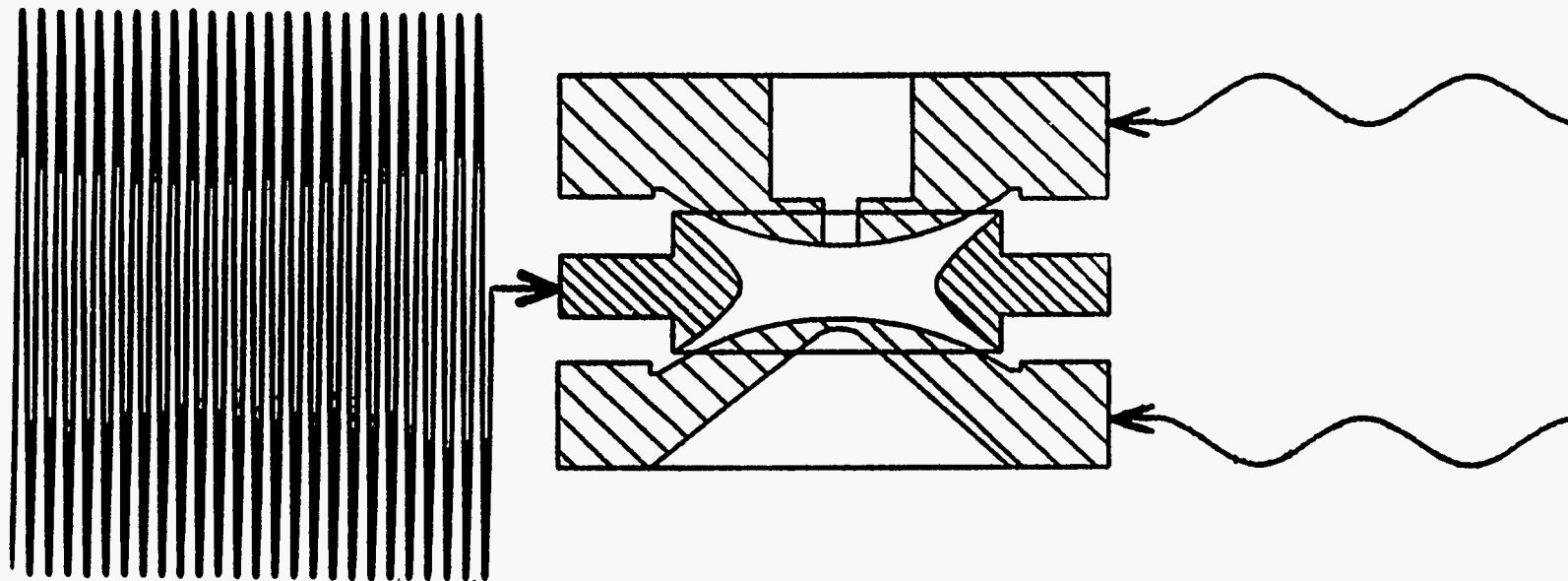

Figure 7. Side-view schematic of the ion trap with a sinusoidal signal applied to the end-caps to effect resonance ejection.

Just as there are a variety of ways to mass-analyze ions with an ion trap, there are a variety of means for mass selecting parent ions for an MS/MS experiment. A commonly employed method is to add a dc voltage to the rf signal applied to the ring electrode for mass selection. This is analogous to the method used for mass analysis and mass selection with the quadrupole mass filter. It effectively combines high pass filtering with low pass filtering to create a notch filter. Low mass ions are ejected in the axial dimension while high mass ions are destabilized in the radial dimension. Resonance ejection is also often used for parent ion isolation.⁵⁶ The amplitude of the ring electrode rf signal is raised to reject low mass ions while frequency of the signal applied to the end-caps is chosen to sweep out ions of higher mass than that of the parent ions. Newer techniques involve the application of a range of frequencies to the end-caps to allow for the accumulation of selected ions during ion injection. For the purpose of explosives detection, these mass selection methods are quite satisfactory.

Collisional activation is used to dissociate ions in the typical ion trap MS/MS experiment, just as it is with beam-type tandem mass spectrometers. However, the process is quite different.⁵⁷ It is beyond the scope of this report to describe all of the differences and their ramifications for studying gas-phase ions. However, to understand why ion trap collisional activation can lead to high sensitivity MS/MS it is important to recognize that collisional activation in the ion trap is a relatively slow heating process which allows for complete dissociation of a parent ion population. Furthermore, since there are no transmission losses associated with ion transport in an ion trapping instrument, the product ions can often be collected with 100% efficiency. Collisional activation is typically effected using "resonance excitation" as opposed to "resonance ejection". The only difference is that the amplitude of the excitation signal applied to the end-caps is insufficient for ion ejection. The presence of helium in the ion trap at a pressure of about one millitorr provides a damping force and a means for dissipation of the energy ions absorb from the field. The ions are heated internally during the course of resonance excitation and may be heated sufficiently to fragment. MS/MS efficiencies can be as high as 100% in favorable cases (see below).

The typical ion trap MS/MS experiment consists of a set of sequential steps beginning with ion formation and accumulation. After the ionization step is completed, further ion accumulation is prevented during the ion manipulation steps. The first ion manipulation step is mass selection effected by one of the methods described above. Collisional activation is then effected either using a single frequency applied to the end-caps or a range of frequencies. The latter approach is newer and overcomes problems associated with tuning and ion-ion interactions (see below). The final step involves mass analysis of the product ions using one of the several mass analysis approaches. A particular advantage of ion trapping instruments is that the mass selection/collisional activation sequence can be repeated using a product ion formed in a previous CID reaction as the parent ion for a subsequent CID experiment. This procedure is commonly referred to as an MSⁿ experiment where n represents the number of stages of mass spectrometry. As many as 13 stages of MS have been demonstrated in a quadrupole ion trap.⁵⁸ The factors that determine the maximum value of n have been discussed.⁵⁹ The capability for MSⁿ where n>2 is a distinct advantage for ion trapping instruments relative to beam-type instruments which require a separate mass analyzer for each stage of MS. The specificity of an analysis may be enhanced dramatically by additional stages of mass spectrometry provided unique information is obtained with each step. For the

explosives detection application, we have yet to encounter a situation in which a third stage of MS is desirable but the ion trap can provide this capability if necessary with a very minor change in software.

The parallels and perpendiculars of ion trap vs. beam-type instrumentation is a big subject, certainly too big for this report. However, the purpose here is to mention enough of the major points to appreciate the merits of these technologies for explosives detection. Therefore, the figures of merit discussed in the previous section for beam-type tandem mass spectrometers, with emphasis on the triple quadrupole instrument, are discussed here for the quadrupole ion trap mated with ASGDI and using the techniques described above. Important characteristics of the quadrupole ion trap relevant to this discussion include:

- **Sensitivity** - Sub-picogram detection limits for explosives can be achieved for explosives-related ions both in the MS and in the MS/MS modes under favorable conditions (see below). The detection limits in the MS/MS mode are clearly superior for the ion trap relative to the beam-type instruments. As discussed below in the comments about dynamic range, the ion trap suffers from ion-ion interactions much more so than beam-type instruments. This problem has been overcome to a large extent with mass-selective ion accumulation methods. However, there remains the possibility for a very intense ion to appear at the same mass/charge as a targeted analyte ion that might affect the accumulation of the ion of interest. We have not encountered such a situation for the species of general interest to the explosives detection community but the potential exists. Fortunately, there are possible approaches to overcome even this problem if it arises. As mentioned above, the favorable duty cycle of the ion trap and the ability to accumulate ions over a wide range of masses simultaneously is an advantage for the ion trap. However, experiments with a reliable vapor generator with both types of technologies are desirable to determine if single ion monitoring with a beam instrument (100% duty cycle) is significantly superior to long ion accumulation time ion trap analysis.
- **Specificity** - The mass resolving power of the ion trap is typically on the order of 1000 in both stages. Mass resolution can be higher by slow scanning but at the expense of duty cycle. As mentioned above, MSⁿ is readily performed in the ion trap as well. Therefore, the capability for high resolution and MSⁿ provided by the ion trap can give extremely high specificity, if needed. This level of potential specificity is not afforded with the triple quadrupole instrumentation. From the practical point of view, however, the specificities of the ion trap and triple quadrupole instruments as they are currently used for explosives detection are comparable and appear to be quite satisfactory for the application.
- **Speed** - The sequence of steps for an ion trap MS/MS experiment can range in duration from 50 milliseconds to over one second. This time range is determined primarily by the ion accumulation time. The analysis time difference between the ion trap and triple quadrupole instruments is not significant in the context of the entire time needed for sampling, preconcentration, and analysis.

- **Size** - The ion trap enjoys a distinct advantage in terms of size and weight. A single analyzer and set of electronics provides MS/MS capabilities, and the ability to tolerate high background pressures (at least 10^{-4} Torr of air has been used routinely) minimizes pumping requirements. The engineering involved in designing a relatively small footprint system (e.g., the size of a PC) should be straightforward.
- **Cost** - Ion traps are the least expensive tandem mass spectrometers. Costs associated with electronics, pumping, and machining are lower than for the triple quadrupole mass spectrometer, for example. It is not difficult to imagine that an ion trap explosives detector can be marketed for less than \$100K given the fact that ion trap GC/MS systems are marketed for less than \$50K.
- **Dynamic range** - As mentioned above, ion traps encounter ion-ion interaction problems much sooner than do beam-type instruments. These problems have been addressed to a large extent by mass-selective ion accumulation methods and by universal collisional activation methods. Nevertheless, dynamic range is expected to be superior with the beam-type instruments. Quantitative measurements of dynamic range with the newer techniques have not yet been made but preliminary measurements suggest ion trap dynamic ranges of 10^5 can be achieved in mixture analysis applications.
- **Scan Flexibility** - Parent ion, neutral loss, and targeted product ion scans are much less conveniently performed with the ion trap than with the triple quadrupole instrument. However, these experiments can be performed if need be. The fact that all experiments are performed with one analyzer simply by changing voltages applied to the electrodes makes the ion trap extremely flexible in the number and types of experiments that might be performed. In principle, provided the electronics to generate the necessary signals are under computer control, simple changes in software can make a wide variety of experiments possible including MS^n studies.

From the point of view of developing a fieldable explosives vapor detector based on tandem mass spectrometry, the advantages enjoyed by the ion trap in terms of MS/MS sensitivity, size, and weight would seem to make it the technology of choice. However, the beam-type instrument remains a powerful tool for explosives analysis but would appear to be most appropriate in a laboratory-based setting.

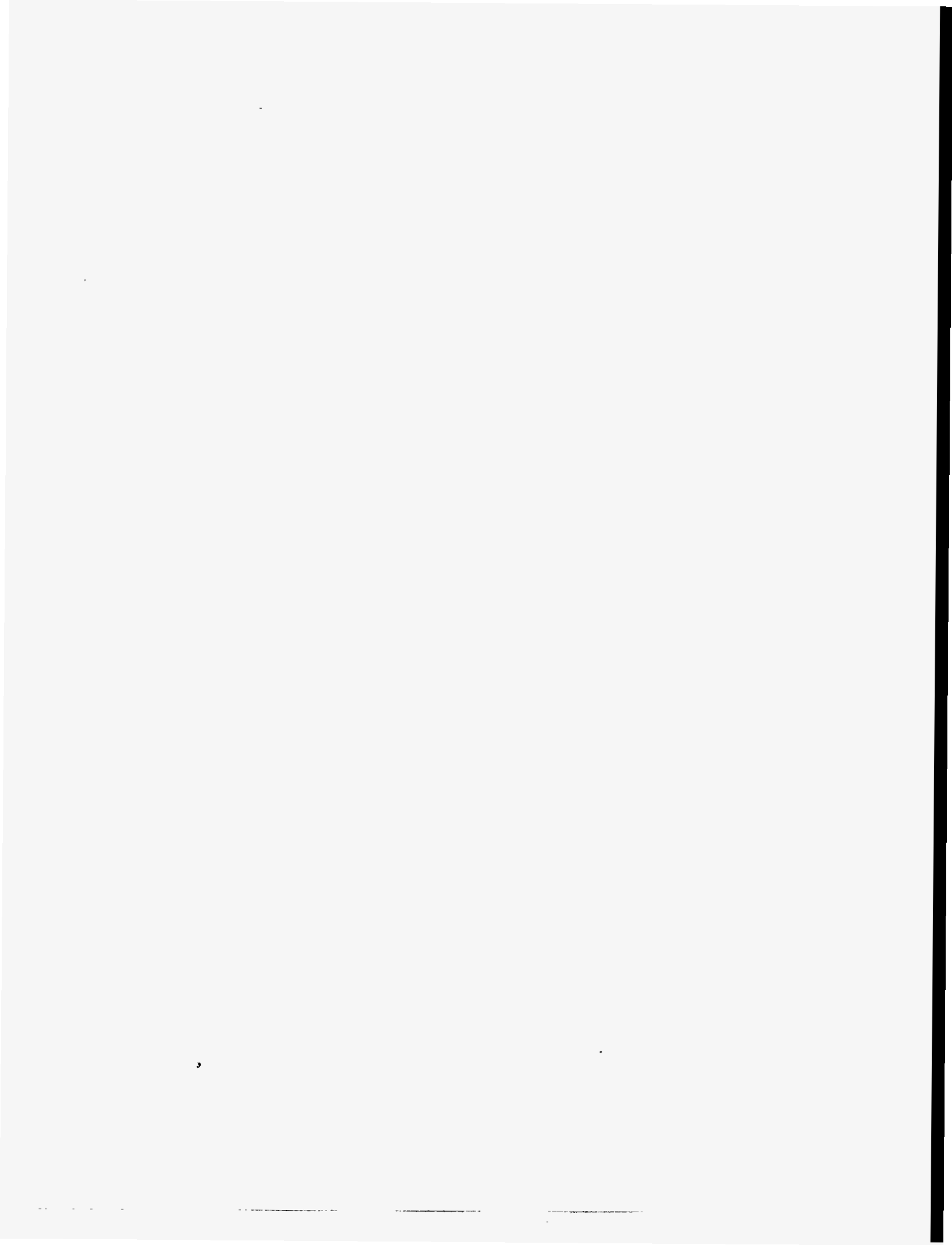

5. QUADRUPOLE ION TRAP TANDEM MASS SPECTROMETRY FOR ANION ANALYSIS

Conventional ion trap mass spectrometry employs electron ionization using a filament mounted on an end-cap to convert vapors present in the ion trapping volume to ions. This *in situ* ionization approach has been shown to be able to detect volatile organics in air down to the low parts per billion by volume level in the positive ion mode. However, electrons are not stored within the ion trap under conditions used for efficient ion storage. Therefore, electron capture within the trapping volume is an inefficient process due to the fact that high number densities of low energy electrons cannot be maintained in the ion trap under conditions optimal for storing ions.^{48,60} For this reason, we interfaced an external ASGDI source with an ion trap^{61,62} to evaluate the strategy of forming anions in a region of high electron number density (roughly 10^{10} cm^{-3}) and subsequently injecting the anions into the ion trap.

An interesting and useful characteristic of the ion trap, particularly for trace detection of targeted compounds, is that its "duty cycle" is highly variable. The duty cycle of the ion trap experiment employing continuous analyte consumption, defined as the fraction of time that ions formed by the ionization method can be measured, is the ion accumulation time divided by the entire time of the experiment. Any analyte consumed during the ion manipulation and mass analysis steps cannot lead to a measurable signal. The duty cycle in a typical experiment can range from a few percent to over 90%. This is an advantage of the ion trapping instruments in that ion accumulation is variable and can be as long as necessary, within trapping efficiency limitations, to accumulate a sufficient number of ions for analysis. Therefore, long ion accumulation times can be used to integrate ions from a weak beam issuing from the ion source whereas short accumulation times are sufficient to accumulate ions from a strong beam. The duty cycle of a beam-type mass spectrometer, on the other hand, is determined by the fraction of time that the spectrometer scans over the m/z range of the analyte ion divided by the total scan range. For a mass/charge range of 50-350, for example, the duty cycle for any particular ion is 1/300 or 0.33%, assuming unit mass resolution. Duty cycle can be increased to 100% in the single ion monitoring mode, of course, but the advantage of single ion monitoring decreases directly with the number of different mass parent ions of interest. There is, therefore, an important compromise between duty cycle and mass range in a beam-type instrument that is largely absent with the ion trap.^{63,64} The ion injection efficiency, defined as the fraction of ions that enter the ion trap during the ion accumulation period that are captured, is estimated to be 5% under optimum conditions using ion injection through an end-cap in the ASGDI/ion trap.

A particularly attractive characteristic of the ion trap as a tandem mass spectrometer is the high efficiency with which parent ions can be converted to product ions.^{57,65} In favorable cases, this efficiency can reach 100%. An early study relevant to this project subjected anions

derived from explosives to ion trap collisional activation to determine if electron detachment would compete effectively with fragmentation, thereby yielding no structural information.⁶⁶ It was found for a variety of nitroaromatic anions, and for virtually all other explosives-derived parent anions, that electron detachment is not an important process under ion trap collisional activation conditions and that, in general, high MS/MS efficiencies are obtained. The mono-nitrotoluene molecular anions are exceptions in this regard. Apparently, the electron affinities of the mono-nitrotoluenes are sufficiently low that electron detachment can compete effectively with dissociation under ion trap collisional activation conditions. Figure 8 illustrates a favorable case in which the major high mass parent ion derived from ASGDI of the explosive pentaerythritol tetranitrate (PETN), which appears at m/z 240 ($M-CH_2ONO_2$)⁻, is subjected to ion trap collisional activation. Figure 8a shows the isolated parent ion and Figure 8b shows the spectrum after the parent ion was subjected to resonance excitation (100 mV, $q_z = 0.136$) for 20 ms. The MS/MS efficiency is essentially 100% for this readily dissociated parent ion. In fact, this parent ion shows a slow but measurable rate of dissociation in the absence of resonance excitation. This slow dissociation under normal ion storage conditions gives rise to the small signal at m/z 62 in the spectrum of Figure 8a.

High MS/MS efficiency (roughly 60%) is also observed for the major parent ion derived from the explosive RDX, as illustrated in the data of Figure 9. The kinetic stability of this parent ion is greater than that of the m/z 240 ion derived from PETN and does not show measurable dissociation in the absence of resonance excitation. Ion trap MS/MS efficiency is, as a rule, inversely related with the kinetic stability of the parent ion as a result of the well-known competition between dissociation and resonance ejection.^{64,65,67} In general, the nitroaromatic parent anions show greater kinetic stabilities than those of the nitrate esters and heterocyclic nitramines. Nevertheless, in virtually all cases involving explosives-related parent ions containing more than one NO_2 or NO_3 group, collisional activation conditions can be obtained that yield MS/MS efficiencies in excess of 40%.

The variable duty cycle of the ion trap combined with high MS/MS efficiency can yield good analytical signals on low levels of analyte even in the MS/MS mode. This is illustrated in Figure 10, which shows the MS/MS spectrum derived from a 500 fg sample of RDX admitted into a heated region leading to the inlet of the ASGDI source. Throughout the course of this experiment, the ion trap was executing a tandem mass spectrometry experiment in which ions were accumulated into the ion trap, parent ions within a mass/charge window of 170-178 were isolated, a resonance excitation signal was applied to the end-cap electrodes at the fundamental secular frequency of m/z 176 ions [corresponding to the $(M-NO_2)$ ⁻ species from RDX], and the product ions were mass analyzed by mass-selective instability.^{54,55} The insert to Figure 4 shows the total ion chromatogram recorded as the 500 fg sample of RDX was vaporized in the heated inlet. The major product ion at m/z 102, resulting from loss of CH_2NNO_2 from the $(M-NO_2)$ ⁻ parent, is observed with good signal-to-noise ratio indicating that the identification of RDX at this level can be made with confidence.

As is often the case with ion trap collisional activation, most of the product ion signal is frequently concentrated in one or two dissociation channels, as a result of the slow heating nature of the process.^{8,68-71} This is clearly the case with the parent ions of PETN and RDX. On the other hand, nitroaromatic anions frequently yield a relatively rich array of product ions, as illustrated by the MS/MS spectrum of the molecular anion of TNT, as shown in Figure 11.

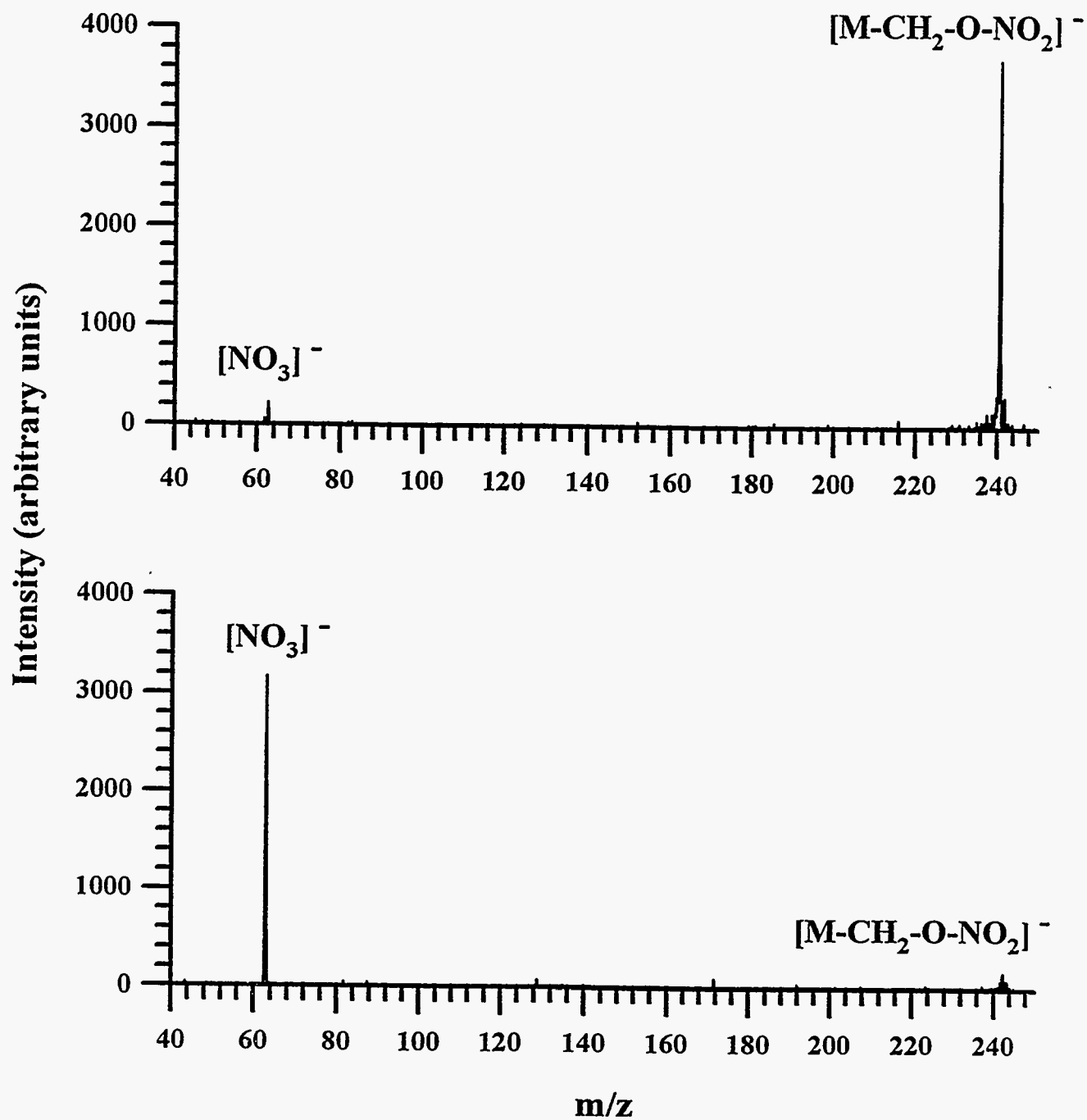

Figure 8. Illustration of the MS/MS efficiency for the $(\text{M-CH}_2\text{ONO}_2)^-$ anion derived from PETN: (a) spectrum of isolated parent ion (b) spectrum after resonance excitation.

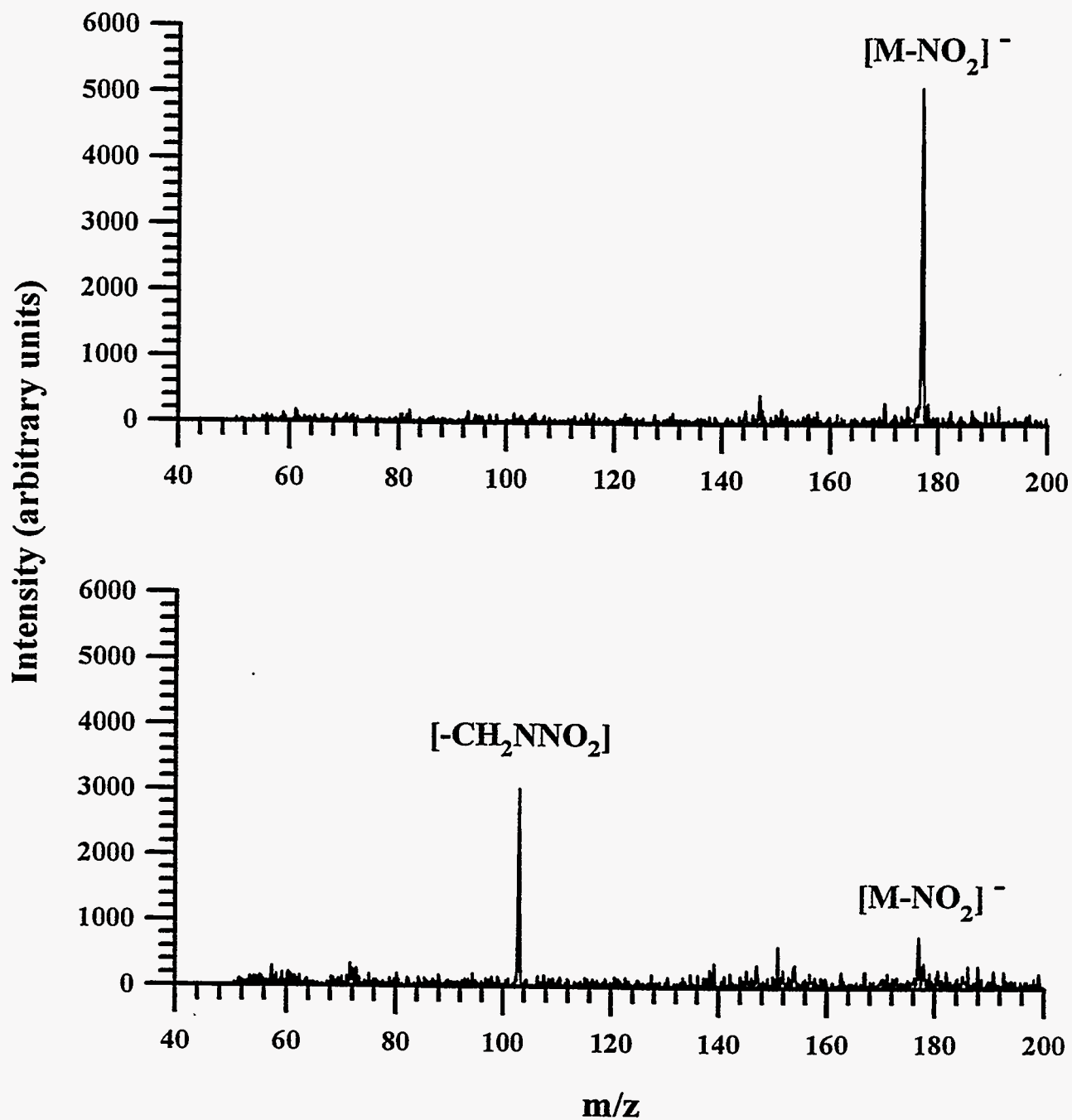

Figure 9. Illustration of the MS/MS efficiency for the $(M-NO_2)^-$ anion derived from RDX: (a) spectrum of isolated parent ion (b) spectrum after resonance excitation.

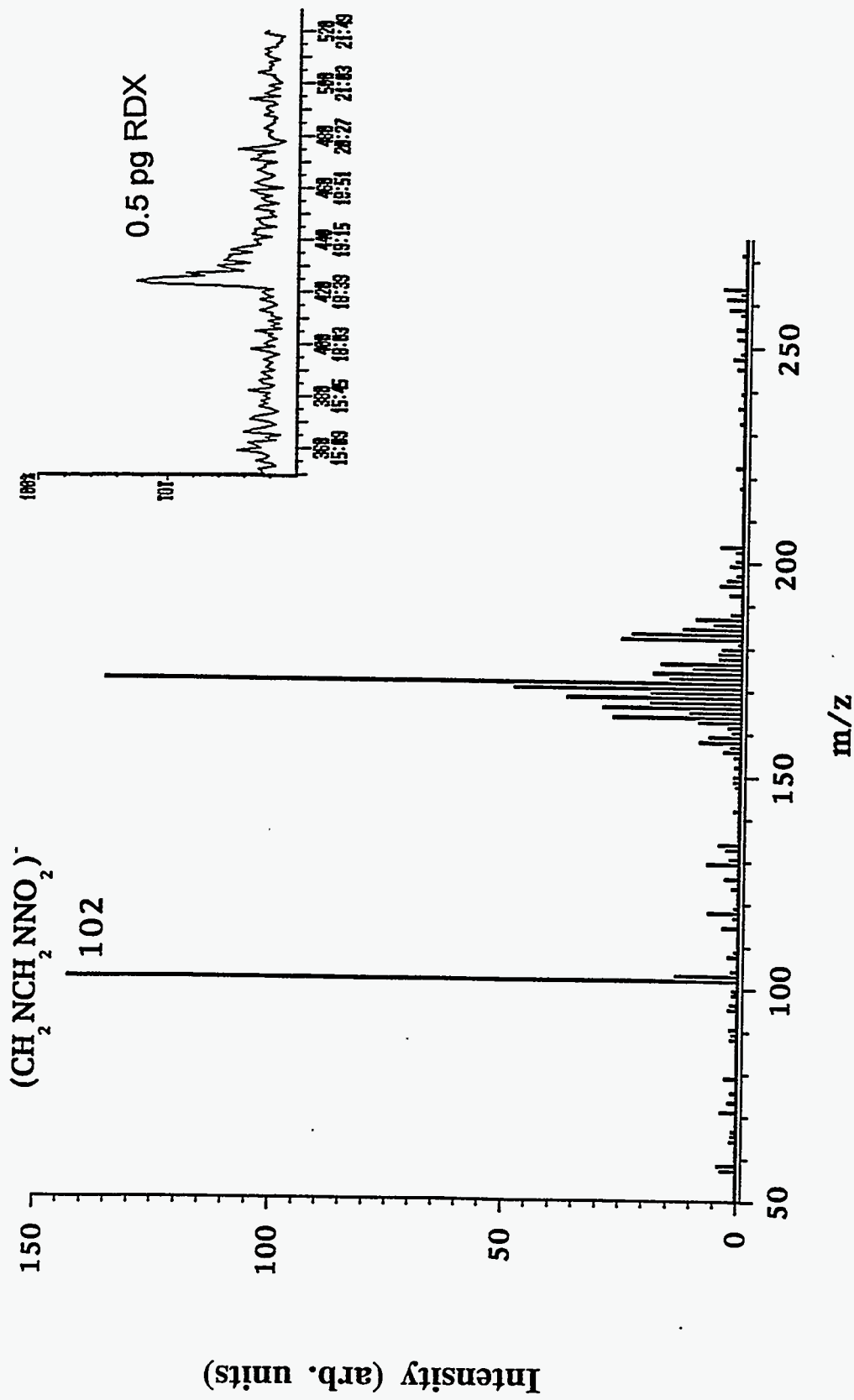

Figure 10. MS/MS spectrum of the $(\text{M}-\text{NO}_2)^-$ parent ion from a 500 fg sample of RDX admitted into a heated region leading to the inlet of the ASGDI source. The inset shows the total ion chromatogram associated with admission of the RDX sample into the heated inlet.

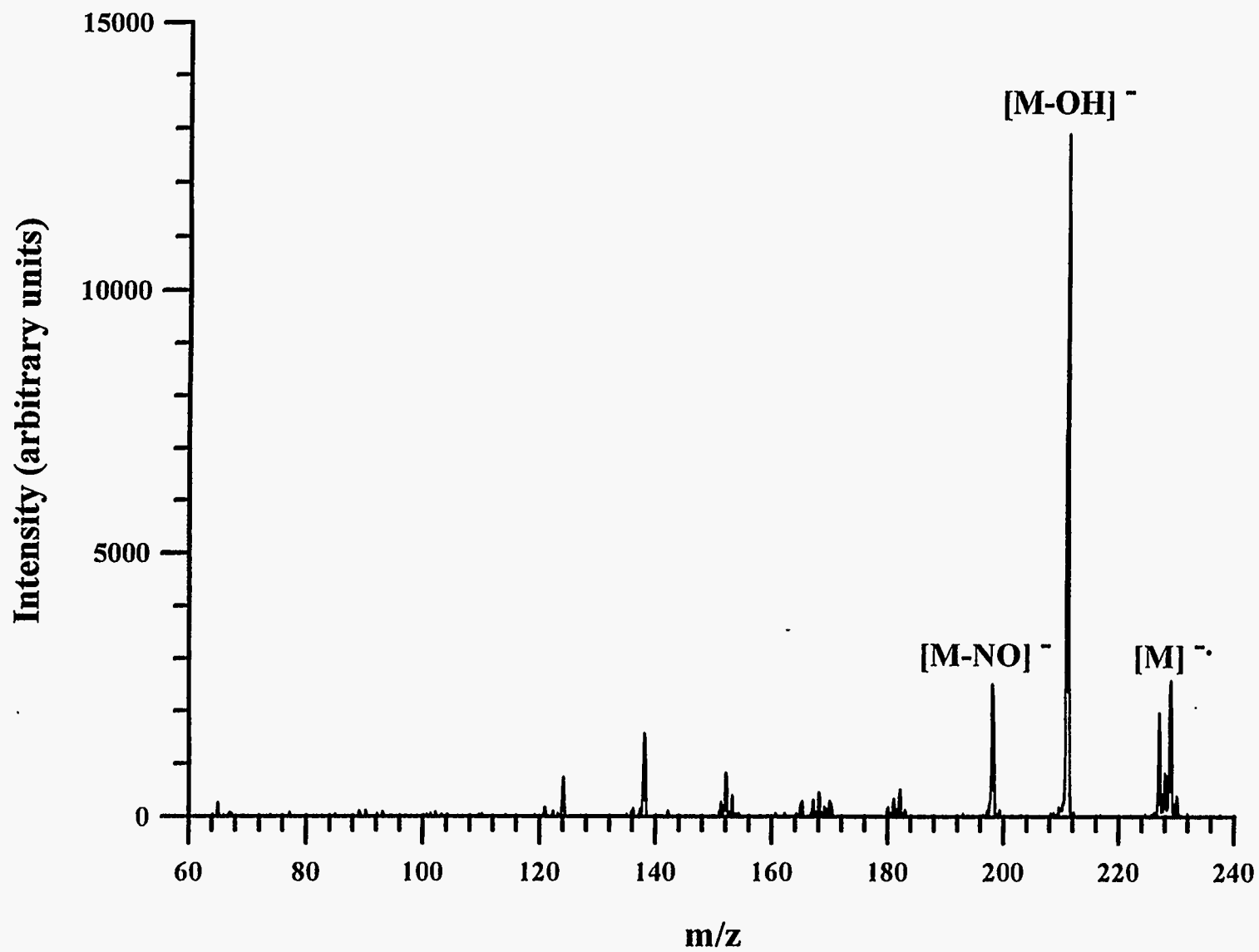

Figure 11. MS/MS spectrum of 2,4,6-trinitrotoluene obtained using single frequency resonance excitation.

Nevertheless, only one or two product ions are typically needed for identification and either the (M-OH)⁻ or (M-NO)⁻ product from the nitrotoluene anions generally serves this purpose. The (M-OH)⁻ ion is observed from species with a nitro group in both the ortho and para positions of toluene and in the ortho position of aniline and phenol.⁷² Table 3 lists some of the parent ions formed by ASGDI and major corresponding products ions of a selected group of species of potential interest for explosives detection.

Despite the attractive features of the ion trap in terms of size, cost, sensitivity, MS/MS capabilities, etc., its finite ion storage capacity has posed serious obstacles to its use as a trace detector in the field under highly variable and ill-defined mixture analysis conditions. The major deleterious effects arising from ion-ion interactions in trace detection are matrix ion effects on the accumulation of targeted ions and ion frequency shifts arising from space charge. The latter phenomenon can adversely affect mass accuracy but a more important consequence in the explosives detection application is the detuning of the resonance excitation condition that can arise when using single frequency resonance excitation for collisional activation. Measures have been developed to address both of these problems and are described below.

The ASGDI source is a relatively "bright" ion source in that it produces up to 10 nano-amperes of anion current under normal operating conditions. Most of this current arises from the major gas components in air and corresponds to species such as O₂⁻, NO₂⁻, O₂(H₂O)⁻, CO₃⁻, HCO₃⁻, NO₃⁻, O₂(H₂O)₂⁻, and higher oxides of nitrogen.⁷³ These species are usually much more abundant than the ions derived from targeted analyte species, particularly when the analyte is present at parts per billion levels and below. As a result of the finite ion storage capacity of the ion trap, simultaneous accumulation of matrix ions and analyte ions can impose a serious limitation on the maximum number of analyte ions that can be stored. In the absence of any measures to allow for the enrichment of particular ions, the relative concentration of the analyte ions becomes independent of ion accumulation time once the storage capacity of the ion trap is reached. This effect was demonstrated using ASGDI/ion trap mass spectrometry of 2,4,6-trinitrotoluene at the low parts per billion level.⁵⁶ It was also demonstrated that a relatively high amplitude resonance ejection signal applied to the end-caps to eject low mass matrix ions during ion accumulation could increase the linearity of TNT molecular anion signal with ion accumulation times from less than 100 ms to 1 s. These results indicated that it might be possible to concentrate the trapped ion population such that the entire ion storage capacity is filled with the analyte ions of interest. Such a capability is necessary for the ion trap to realize its potential for amplifying weak ion currents of species of interest issuing from an ion source in the presence of much higher ion currents of uninteresting species.

The matrix ion problem has been addressed in Fourier transform ion cyclotron resonance by the application of the stored waveform inverse Fourier transform (SWIFT) technique.⁷⁴ Several approaches to mass selective ion accumulation in the ion trap have also been evaluated recently for the ion injection scenario^{13,75-77} including the use of tailored waveforms. For example, both SWIFT⁷⁵ and filtered-noise fields^{76,77} (FNFs) have been demonstrated to be useful for mass-selective ion accumulation. The Teledyne 3DQ system is supplied with the capability for FNF generation and we have therefore used this approach in the explosives detection area. Figure 12 illustrates the utility of an FNF during ion accumulation in cases where the analyte ion is not the most abundant species injected into the ion trap that can be stored. Two plots are shown, each of which represents the molecular anion signal of 2,4-

Table 3. Parent ions and major product ions from selected species of interest in explosives detection resulting from ion trap collisional activation.

<u>Compound</u>	<u>Parent ion(s)[*]</u>	<u>Major product ion(s)[*]</u>
2,4,6-TNT	M ⁻ (227)	(M-OH) ⁻ (210);(M-NO) ⁻ (197)
2,4-DNT	M ⁻ (182)	(M-OH) ⁻ (165);(M-NO) ⁻ (152)
2,6-DNT	M ⁻ (182)	(M-NO) ⁻ (152)
2,3-DNT	M ⁻ (182)	(M-NO) ⁻ (152)
3,4-DNT	M ⁻ (182)	(M-NO) ⁻ (152)
DNBs (o,m,p)	M ⁻ (168)	(M-NO) ⁻ (138)
nitrobenzene	M ⁻ (123)	(M-NO) ⁻ (93)
picric acid	M ⁻ (229)	(M-OH) ⁻ (212)
2,6-DNP	M ⁻ (184)	(M-OH) ⁻ (167)
2,4-DNP	M ⁻ (184)	(M-OH) ⁻ (167);(M-NO) ⁻ (154)
2,3-DNP	M ⁻ (184)	(M-OH) ⁻ (167);(M-NO) ⁻ (154)
2,5-DNP	M ⁻ (184)	(M-OH) ⁻ (167);(M-NO) ⁻ (154)
3,4-DNP	M ⁻ (184)	(M-NO) ⁻ (154);(M-OH) ⁻ (167)
o-MNP	M ⁻ (139)	(M-OH) ⁻ (122)
m-MNP	M ⁻ (139)	(M-NO) ⁻ (109)
p-MNP	M ⁻ (139)	(M-NO) ⁻ (109)
2,4-dinitroaniline	M ⁻ (183)	(M-OH) ⁻ (166);(M-NO) ⁻ (153)
2,4-dinitrophenylhydrazine	(M-NO) ⁻ (168)	(M-NO) ⁻ (138);NO ₂ ⁻ (46)
tetryl	(M-NO ₂) ⁻ (241)	(P-CH ₂ N) ⁻ (213) (P-CH ₃ NO ₂) ⁻ (180) (P-HNO ₂) ⁻ (194)
PETN	(M-CH ₂ ONO ₂) ⁻ (240)	NO ₃ ⁻ (62)
NG	NO ₃ ⁻ (62)	NO ₂ ⁻ (46)
EGDN	NO ₃ ⁻ (62)	NO ₂ ⁻ (46)
RDX	(M-NO ₂) ⁻ (176) (M-NO ₂ ,HNO ₂) ⁻ (129) CH ₂ N(NO ₂)CH ₂ N ⁻ (102)	(P-CH ₂ NNO ₂) ⁻ (102) (P-HNO ₂) ⁻ (82) NO ₂ ⁻ (46)
HMX	(M-NO ₂) ⁻ (250)	(P-CH ₂ NNO ₂) ⁻ (176) (P-HNO ₂) ⁻ (203)
sulfur	(M-NO ₂ ,CH ₂ NNO ₂) (176) S ₄ ⁻ (128)	(P-CH ₂ NNO ₂) ⁻ (102) S ₃ ⁻ (96)

*M denotes the molecule and P denotes the parent ion. In cases where the molecular anion is the parent ion, M is used rather than P. See Table 2 for abbreviations and common names.

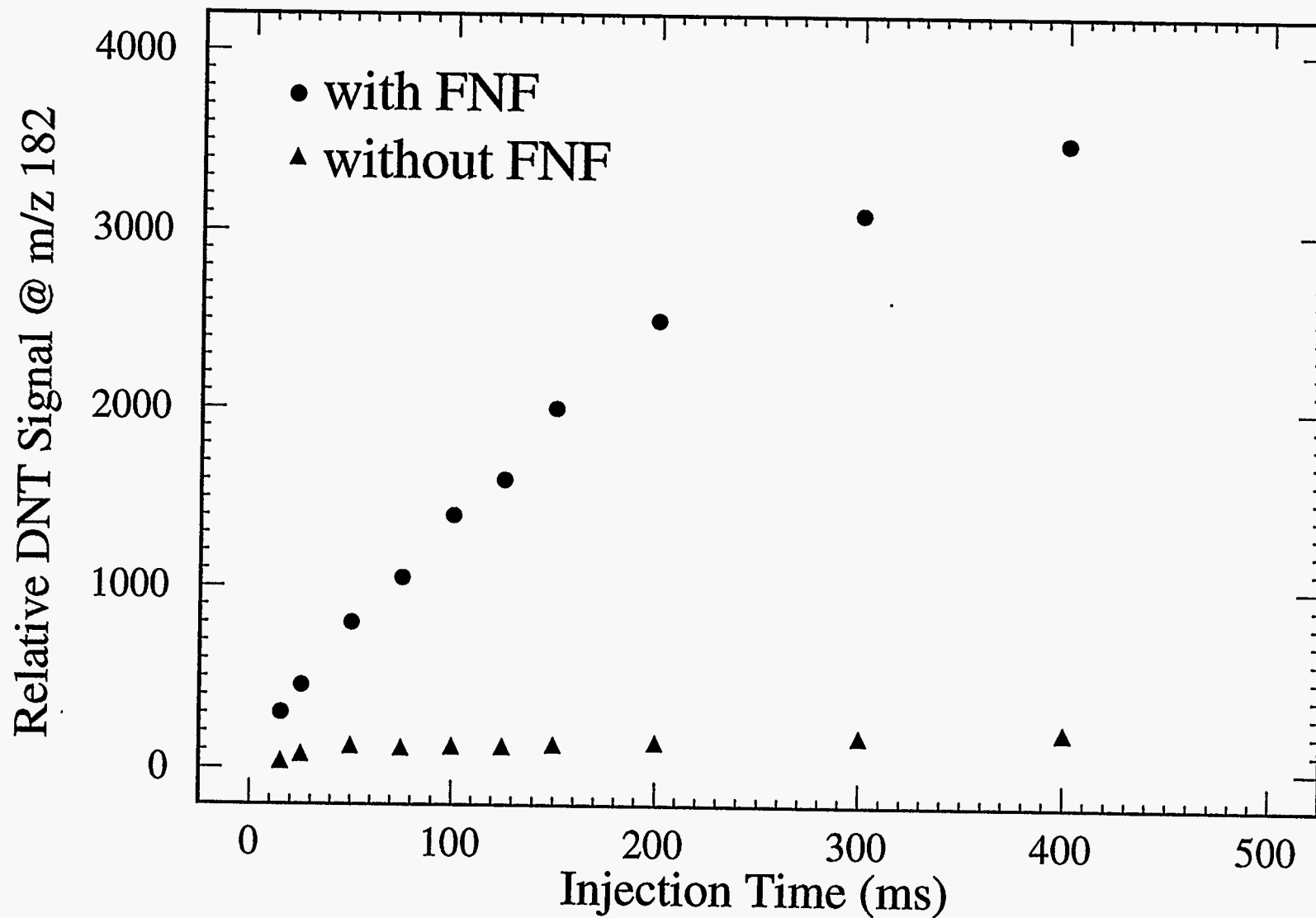

Figure 12. Molecular anions signals of 2,4-dinitrotoluene obtained as a function of ion accumulation time with (filled circles) and without (filled triangles) the use of a filtered-noise field to effect mass selective ion accumulation.

dinitrotoluene (DNT). The plot acquired under conditions in which all ions above a low m/z cut-off of 20 were allowed to accumulate shows the DNT signal to plateau within 30 ms of ion accumulation time. This plateau arises from the fact that the ion storage capacity of the ion trap is quickly reached when all ions are accumulated. The second plot was derived using an FNF waveform in which only anions within a mass/charge window of m/z 181-183 were allowed to accumulate. Note that the DNT signal increased more or less linearly up to about 80 ms. Beyond an ion injection period of 80 ms, the growth of the DNT signal did not keep pace with injection time. Beyond an injection time of 500 ms (data not shown in the figure) no further increases in DNT signal were observed. This is due to the fact that the DNT ions had reached the full ion storage capacity of the ion trap. The significance of data such as these is that the full inherent dynamic range of the ion trap can be accessed even for ions of low abundance in the mass spectrum provided "matrix" ions are excluded.

A particularly attractive aspect of using tailored waveforms for mass selection is that they can be customized to allow for an arbitrary number of ions of various mass/charge ratios to be selected simultaneously. Figure 13 illustrates a situation in which a tailored waveform designed to mass-selectively accumulate several anions simultaneously can be highly useful in an explosives detection scenario. Figure 13a shows a portion of the ASGDI/ion trap mass spectrum of the head space vapors of black powder in air following an ion accumulation period of 1 s with a low mass/charge cutoff of 25. Note that there is extensive peak broadening due to ion/ion interactions (the vertical scale is expanded to coincide with that of Figure 13b). Figure 13b shows the results of the same experiment in which a filtered-noise field was applied during ion accumulation with frequency notches corresponding to ions of m/z 64, 96, and 128. The masses correspond to those of S_2^- , S_3^- , and S_4^- . These ions arise from the sulfur component of black powder. In the absence of the FNF, it is very difficult to identify the presence of these ions due to the degradation of resolution arising from space charge and the deleterious matrix ion effects on accumulation of the sulfur anions. Clearly, mass-selective ion accumulation is useful in detecting sulfur anions and the capability for accumulating all three of the major anions from sulfur during a single ion accumulation period enhances specificity because identification can be based on the criterion that all three ions be present.

The matrix ion effect problem in ion accumulation arises most often from the presence of ions at mass/charge ratios different from those of the targeted species. The tactics just described would not be useful, however, for matrix ions isobaric with the analyte ions. Tandem mass spectrometry has the potential to solve this problem. Unfortunately, the analyte ions themselves can affect one another and, in fact, they are the most likely to do so since they experience the same well-depth. Of greatest concern in a trace detection scenario is the potential for ion/ion interactions leading to a sufficient change in the analyte ion frequency distribution to cause the ions to shift from the applied resonance excitation frequency in an MS/MS experiment. The original demonstration of collisional activation in the ion trap,⁶⁴ and still a commonly used approach, employed a single frequency resonance excitation voltage tuned to maximize dissociation of the analyte ion of interest. Tuning is sensitive to ion number which, of course, poses a problem when the number of analyte ions is not carefully controlled. Such a situation prevails in trace detection scenarios and frequently in on-line separation coupled with mass spectrometry applications. For this reason, several approaches have been developed for non-mass-selective collisional activation to reduce tuning requirements and to overcome the ion/ion interaction problem. These approaches include, for example, the use of random noise

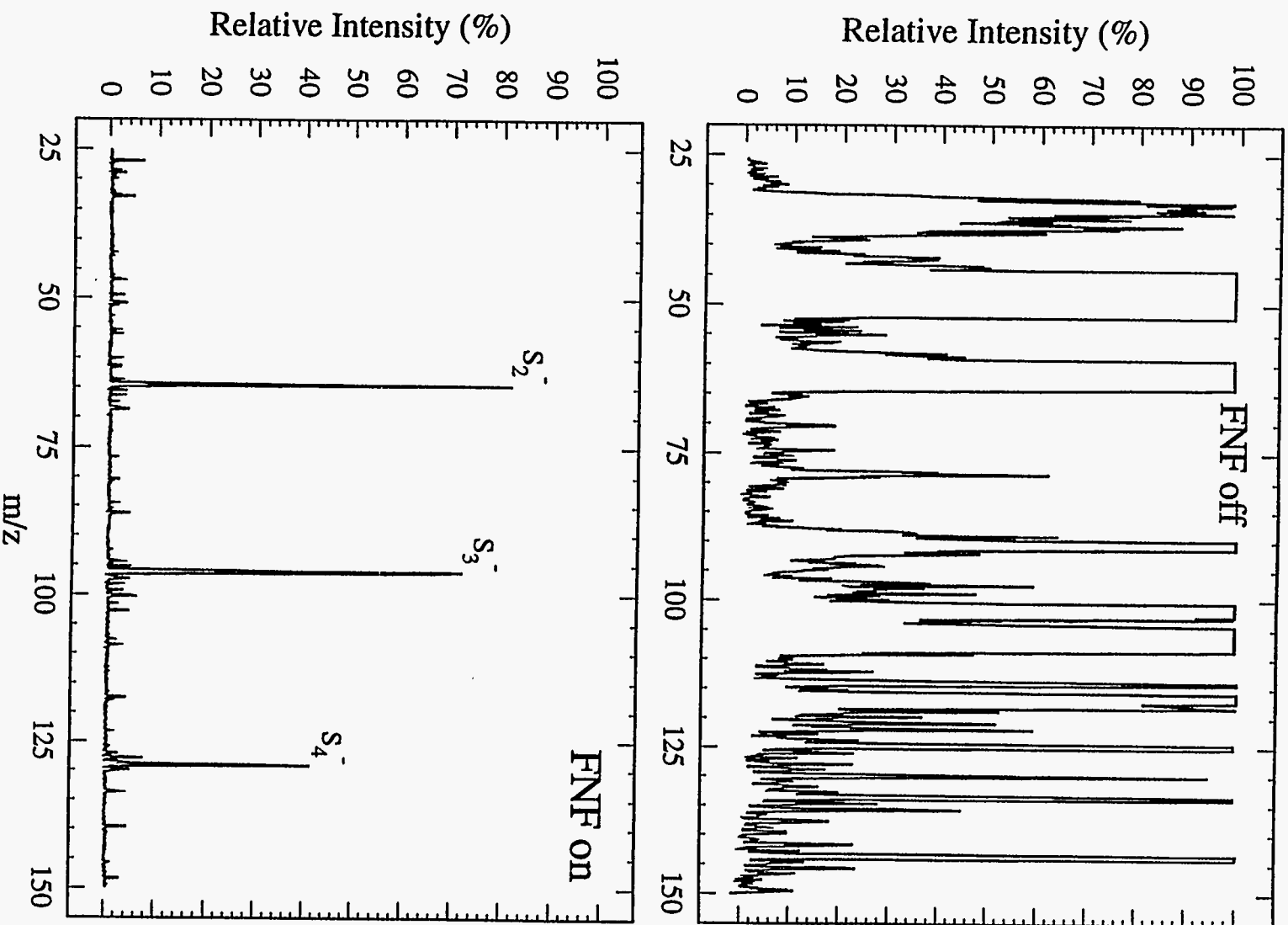

Figure 13.

ASGD mass spectra derived from sampling head space vapors of black powder in the absence of mass selective ion accumulation (a) and using a filtered-noise field to allow for the selective accumulation of ions at m/z 64, 96, and 128 (b).

applied to the end-caps during the ion activation period,⁷⁸ swept frequencies applied to the end-caps,⁷⁹ the use of narrow frequency bands applied to the end-caps,⁷⁹ and the application of a low frequency signal applied to the end-caps.⁸⁰ All of these approaches have proved to be effective in mitigating the space charge problem associated with collisional activation using single frequency resonance excitation. Broad-band activation methods, for example, have proved to be insensitive to space charge but, at least for relatively stable ions, the MS/MS efficiency can be up to four times poorer than single frequency resonance excitation. This may be due to the fact that frequency shifting as a function of ion oscillatory amplitude⁸¹ (arising from the presence of higher order fields⁸²), tends to reduce parent ion losses in the single frequency experiment. However, acceleration of parent ions can continue if the band of frequencies applied to the end-caps encompasses the frequency shift associated with the higher order fields. In any event, many of the parent anions derived from explosives are readily fragmented and show efficiencies under broad-band collisional activation conditions comparable to those obtained under single frequency collisional activation conditions.

The development of mass-selective ion accumulation techniques and non-mass-selective ion activation methods have largely overcome the major problems associated with the use of the ion trap for trace high explosives detection in the field. The ability to use specific tailored waveforms in series provides extreme flexibility in defining MSⁿ experiments. In the explosives detection scenario, it is desirable to monitor for as many different explosives as possible, as opposed to using a separate ion trap experiment for each targeted compound in series. The ability to concatenate tailored waveforms for ion accumulation, ion isolation, ion activation, etc. can make parallel monitoring possible. We have recently illustrated parallel monitoring for the three nitroaromatic explosives 2,4-DNT, 2,4,6-TNT, and tetryl.⁸³ An example is given here for TNT, RDX, and PETN. This example illustrates a possible parallel monitoring application and also constitutes a case that highlights many of the points already discussed in this overview.

Figure 14a shows the ASGDI/ion trap mass spectrum of air containing sub-parts per billion levels of the three high explosives TNT, RDX, and PETN following a 400 ms ion accumulation period at a low m/z cutoff of 35. The most abundant high mass ions for these compounds formed by ASGDI appear at m/z 227, m/z 176, and m/z 240, respectively (see Table 2). These ions constitute very small fractions of the total anion signal in the spectrum. In fact, the anion at m/z 176, if present, cannot be clearly identified due to the presence of ions at nearby masses and to peak broadening resulting from space charge. Essentially no signal is seen at m/z 240. Figure 14b shows the mass spectrum of the same sample mixture using a filtered-noise field to allow for accumulation of ions within mass/charge windows of m/z 172-180, m/z 223-232, and m/z 235-245 under otherwise identical conditions. In this case, all three parent ions are clearly apparent suggesting that the accumulation of the matrix ions in the experiment leading to the spectrum of Figure 14a adversely affected the accumulation of the targeted ions. The peak arising from PETN is clearly apparent in Figure 14b and the signal level due to the molecular anion of TNT is roughly a factor of four greater in Figure 14b than it is in Figure 14a. Likewise, the signal due to RDX is at least four times greater in Figure 14b than it is in Figure 14a. The experiment leading to Figure 14b is analogous to the experiment leading to the spectrum of Figure 13b, in that multiple ions of significantly different masses are selectively accumulated simultaneously. In this example, however, three different targeted

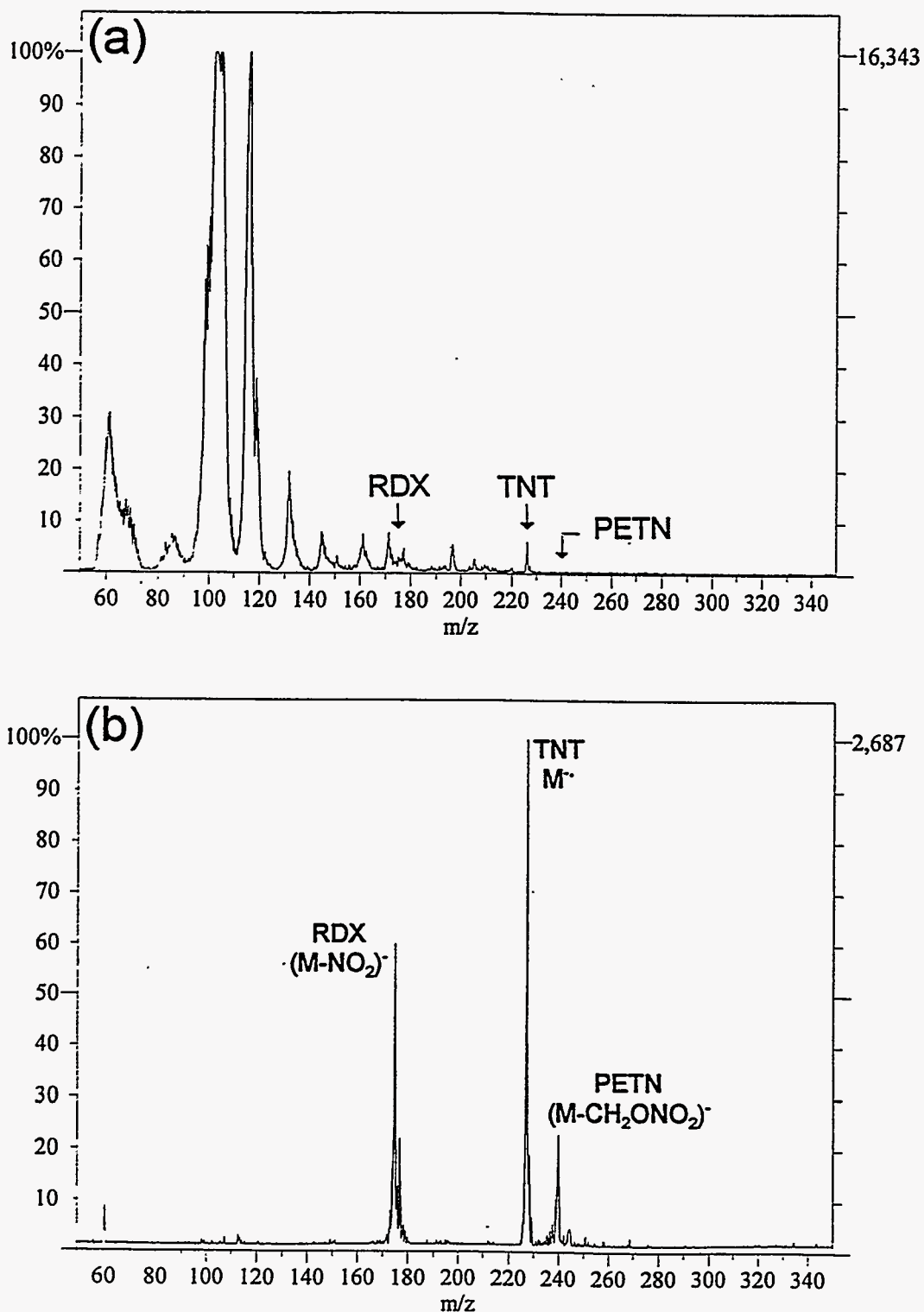

Figure 14. ASGDI mass spectra derived from sampling a mixture of RDX, PETN and TNT in the absence of mass selective ion accumulation (a) and using a filtered- noise field to allow for the selective accumulation of ions within mass/charge windows of m/z 172-180, m/z 223-232, and m/z 235-245 (b).

analytes are reflected in the spectrum whereas three ions from a single targeted analyte, molecular sulfur, are detected in the experiments leading to Figure 13b.

The detection of several ions associated with a single analyte provides greater specificity than the detection of a single ion alone. As an example, there is greater specificity for the detection of sulfur in the experiment associated with Figure 13 than for any of the three analytes targeted in the experiment associated with Figure 14. Further stages of mass spectrometry, however, can enhance specificity by providing more diagnostic ions. Figure 15 shows the results of an experiment in which a second filtered-noise field was used after the mass selective ion accumulation period associated with the spectrum of Figure 14b to collisionally activate ions of m/z 176, 227, and 240 for 20 ms (low m/z cutoff = 50). The resulting spectrum, which should be compared with that of Figure 14b, shows a variety of product ions associated with the targeted ions. For example, intense peaks appear at m/z 62, corresponding to the major decomposition product from the PETN parent ion, m/z 102, corresponding to the major decomposition product from RDX, and m/z 210 and 197, corresponding to the major decomposition products from TNT. Most of the other intense product ions are known decomposition products of TNT.

It is important to recognize that the specificity for each of the targeted analyte ions associated with the experiment leading to Figure 15 is less than that associated with separate MS/MS experiments conducted in series. The experiment leading to Figure 15 is not a true MS/MS experiment in that the parent-product genealogy is not strictly defined. However, the point of this example is to illustrate that concatenated tailored waveforms can be used to devise a scheme that allows for the monitoring of several different targeted compounds in parallel, thereby trading specificity for speed. In this case, the ion accumulation waveform serves dual purposes. It serves as a mass selection step while at the same time minimizing deleterious matrix ion effects. That is, parent ion selection occurs during the ion accumulation period as opposed to afterwards. The second waveform provides ion activation, the mass/charge specificity of which can be tailored to suit the analysis. The ion activation waveform can consist of a single frequency for each targeted ion, a narrow band of frequencies for each targeted ion, or a broad band of frequencies encompassing the entire mass/charge range of interest. Specificity can be enhanced further, in favorable cases, by adding additional mass selection and ion isolation steps, as was demonstrated for the three nitroaromatic compounds DNT, TNT, and tetryl.⁸³

The preceding discussion is intended to summarize the characteristics of the quadrupole ion trap as a mass analyzer for use in trace detection of high explosives and other species of interest. The analytical merits of the ion trap for explosives detection, when used in combination with atmospheric sampling glow discharge ionization can be summarized as follows: (1) Sub-picogram detection limits for explosives can be achieved, under favorable conditions, for explosives-related ions both in the MS and in the MS/MS modes. The generally high MS/MS efficiencies obtained with the ion trap allow it to provide enhanced specificity without a major loss in signal. (2) In terms of specificity, the mass resolving power of the ion trap is typically on the order of 1000 in both stages. Mass resolution can be higher by slow scanning^{84,85} but at the expense of duty cycle. As mentioned above, multiple stages of mass spectrometry can also be performed. Therefore, the capability for high resolution and MSⁿ provided by the ion trap can give extremely high specificity, if needed. The remarkable

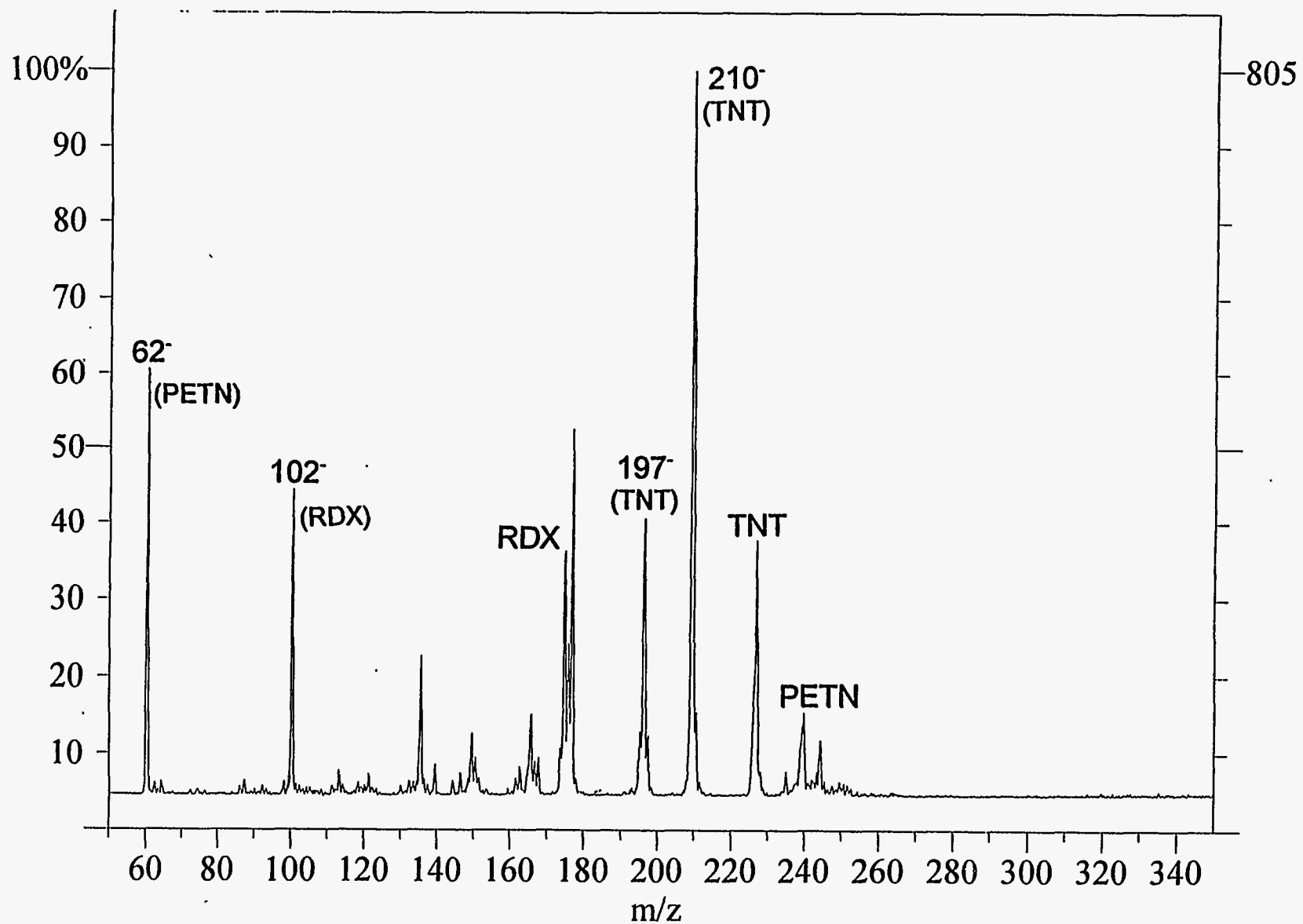
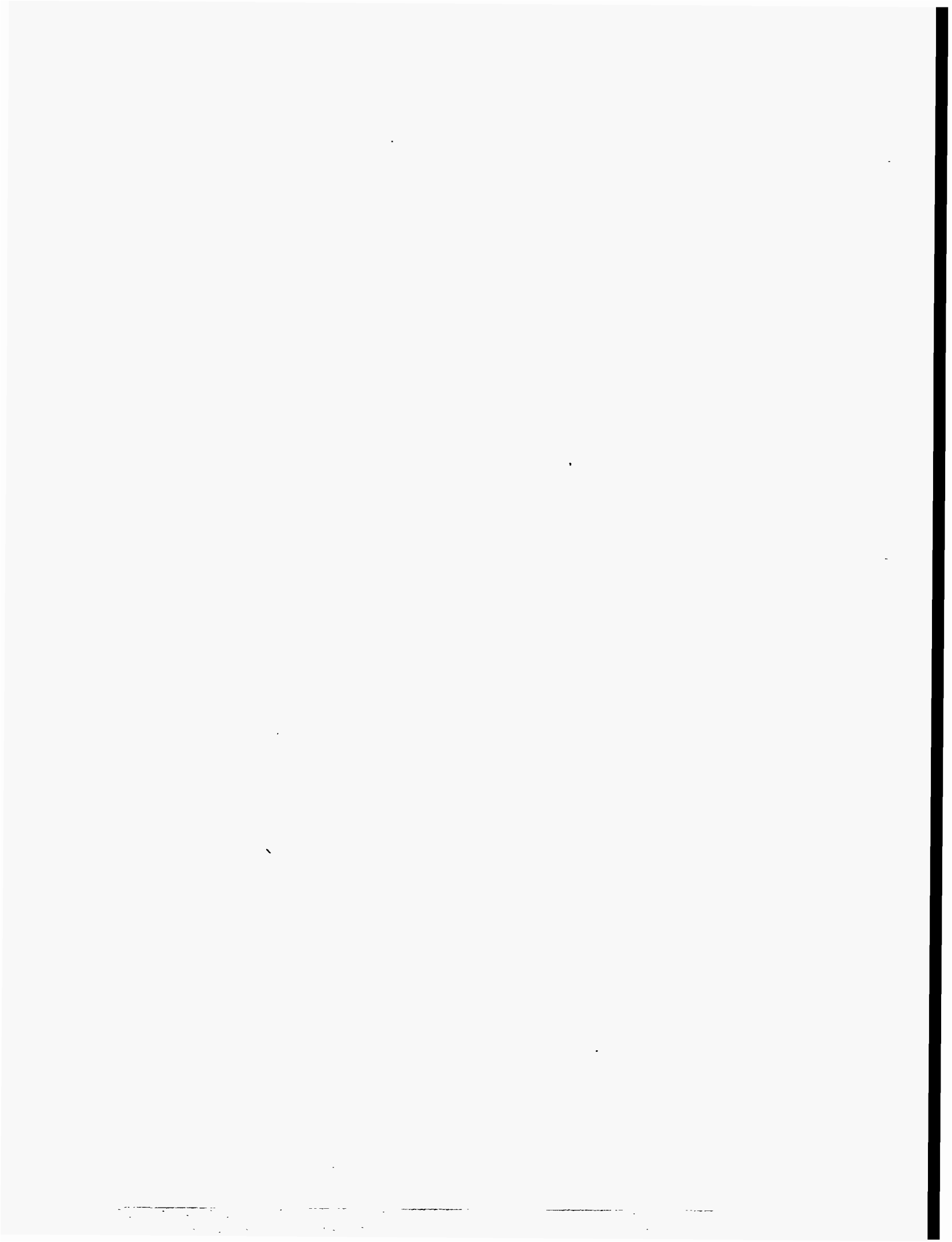

Figure 15. Spectrum resulting from the use of consecutive filtered-noise fields to effect parallel monitoring for RDX, PETN, and TNT. The first filtered-noise field was used to mass selectively accumulate ions within the mass/charge windows of m/z 172-180, m/z 223-232, and m/z 235-245. The second filtered noise field was used to collisionally activate ions at m/z 176, 227, and 240.

experimental flexibility of the ion trap with its capability for concatenated tailored waveforms is particularly advantageous in that trade-offs in speed, sensitivity, and specificity can be made to suit the needs of the detection scenario. (3) In terms of speed, the sequence of steps for an ion trap MS/MS experiment can range in duration from 50 milliseconds to over one second, depending primarily upon the ion accumulation time. Relative to the time required for sample accumulation and transport, analysis times on the order of one second are sufficient for most trace detection scenarios. (4) With respect to size, the ion trap enjoys a distinct advantage in terms of size and weight over most any other form of tandem mass spectrometer. A single analyzer and set of electronics provides MS/MS capabilities and the ability to tolerate high background pressures (at least 10^{-4} Torr of air has been used routinely), thus minimizing pumping requirements. (5) In terms of cost, ion traps are the least expensive tandem mass spectrometers currently being marketed. The price for an ion trap-based explosives detector would be driven by many factors, of course. However, it would appear that the reductions in cost of commercially available ion traps and the increases in capabilities currently taking place for laboratory-based systems are positive signs for the evolution of a trace vapor detection system. (6) As mentioned above, ion traps encounter ion-ion interaction problems much sooner than do beam-type instruments. These problems have been addressed to a large extent by mass-selective ion accumulation methods and by universal collisional activation methods. Quantitative measurements of dynamic range with the newer techniques have not yet been made but preliminary measurements suggest an ion trap dynamic range of 10^5 can be achieved in mixture analysis applications using glow discharge ionization.

6. SUMMARY

Advances in analytical instrumentation are making powerful analytical tools increasingly available for use outside of the laboratory setting. The detection of trace quantities of targeted compounds, such as high explosives, is a problem requiring extremely powerful technology. Tandem mass spectrometry is clearly attractive from the point of view of specificity, sensitivity, and speed. The quadrupole ion trap is a tandem mass spectrometer that is very attractive due to its small size and relatively low cost. At its current state of maturity, there are no major technical barriers to its use in the field for trace detection scenarios provided effective sampling and introduction procedures for the specific application are employed. The analysis of negative ions is particularly well-suited for trace detection of explosives in complex and uncontrolled matrices due to the high selectivity it affords. Atmospheric sampling glow discharge ionization is a simple, rugged, and sensitive means for creating negative ions. Due to the gas dynamics and the selectivity of the ionization process, ASGDI is relatively insensitive to matrix effects in the negative ionization mode. The combination of an external negative ionization source, such as a glow discharge source, with the quadrupole ion trap, therefore, constitutes an unusually powerful candidate approach for both detecting and identifying trace quantities of explosives in the field.



REFERENCES

1. J. Yinon and S. Zitrin, "The Analysis of Explosives," Pergamon Series in Analytical Chemistry, Volume 3, Pergamon Press, Oxford, 1981.
2. J. Yinon, "Forensic Applications of Mass Spectrometry," CRC Press, Boca Raton, FL, 1994.
3. U.S. Congress, Office of Technology Assessment, "Technology Against Terrorism: The Federal Effort," OTA-ISC-481, Washington, DC, U.S. Government Printing Office, July 1991.
4. "Tandem Mass Spectrometry," F.W. McLafferty (Ed.), Wiley and Sons, New York, 1982.
5. K.L. Busch, G.L. Glish, and S.A. McLuckey, "Mass Spectrometry/Mass Spectrometry: Techniques and Applications of Tandem Mass Spectrometry," VCH Publishers, New York, 1988.
6. W. Paul, *Angew. Chem. Int. Ed. Engl.*, **29**, 739 (1990).
7. J.F.J. Todd, *Mass Spectrom., Rev.* **10**, 3 (1991).
8. R.E. March, *Int. J. Mass Spectrom. Ion Proc.*, **118/119**, 71 (1992).
9. R.G. Cooks and R.E. Kaiser, Jr., *Acc. Chem. Res.*, **23**, 213 (1990).
10. R.G. Cooks, G.L. Glish, S.A. McLuckey, and R.E. Kaiser, Jr., *Chem. Eng. News*, **69**, 26 (1991).
11. S.A. McLuckey, G.L. Glish, K.G. Asano, and B.C. Grant, *Anal. Chem.*, **60**, 2220 (1988).
12. S.A. McLuckey, G.L. Glish, and G.J. Van Berkel, "Proceedings of the 38th ASMS Conference on Mass Spectrometry and Allied Topics," June 3-8, 1990, Tucson, AZ, p. 512.
13. D.C. Duckworth, C.M. Barshick, D.H. Smith, and S.A. McLuckey, *Anal. Chem.*, **66**, 92 (1994).
14. D.C. Duckworth, unpublished results, Oak Ridge National Laboratory, 1995.

15. J. Yinon, *Mass Spectrom. Rev.*, **1**, 257 (1982).
16. W.R. Carper, R.C. Dorey, K.B. Tomer, and F.W. Crow, *Org. Mass Spectrom.*, **19**, 623 (1984).
17. J. Yinon, D.J. Harvan, and J.R. Hass, *Org. Mass Spectrom.*, **17**, 321 (1982).
18. S.A. McLuckey, G.L. Glish, and J.A. Carter, *J. Forens. Sci.*, **30**, 773 (1985).
19. H.R. Schulten and W.D. Lehmann, *Anal. Chim. Acta*, **93**, 19 (1977).
20. S.N. Ketkar, J.G. Dulak, W.L. Fite, J.D. Buchner, and S. Dheandhanoo, *Anal. Chem.*, **61**, 260 (1989).
21. B.A. Thomson, W.R. Davidson, and A.M. Lovett, *Environ. Health Perspectives*, **36**, 77 (1980).
22. J.B. French, B.A. Thomson, W.R. Davidson, N.M. Reid, J.A. Buckley, "Mass Spectrometry in the Environmental Sciences," F.W. Karasek (Ed.), Pergamon Press, Oxford, 1982.
23. S. Boumsellek and A. Chutjian, *Anal. Chem.*, **64**, 2096 (1992).
24. S. Boumsellek, S.H. Alajajian, and A. Chutjian, *J. Am. Soc. Mass Spectrom.*, **3**, 243 (1992).
25. J.A. Laramee and M.L. Deinzer, *Anal. Chem.*, **64**, 719 (1994).
26. D.M. Chambers, S.A. McLuckey, and G.L. Glish, *Anal. Chem.*, **64**, 2096 (1992).
27. M.L. Langford and J.F.J. Todd, *Org. Mass Spectrom.*, **23**, 773 (1993).
28. K.G. Asano, S.A. McLuckey, and G.L. Glish, *Spectros. Int. J.*, **8**, 191 (1990).
29. G.E. Spangler and M.J. Cohen in "Plasma Chromatography," T.W. Carr (Ed.), Plenum Publishing Corp., New York, 1984.
30. G.A. Eiceman and Z. Karpas, "Ion Mobility Spectrometry," CRC Press, Boca Raton, FL, 1994.
31. E.C. Horning, M.G. Horning, D.I. Carroll, I. Dzidic, and R.N. Stillwell, *Anal. Chem.*, **45**, 936 (1973).
32. M. McKeown and M.W. Siegal, *Am. Lab.*, November, **89** (1975).
33. J.R. Hobbs, U.S. D.O.T. Report No. FAA-RD-74-134, Transportation Systems Center, Cambridge, MA (1974).

34. A.G. Harrison, "Chemical Ionization Mass Spectrometry," 2nd Edition, CRC Press, Boca Raton, FL, 1992.
35. W.R. Davidson, B.A. Thompson, T. Sakuma, W.R. Scott, A.K. Akery, and R. Sleeman, "Proceedings of the First International Symposium on Explosive Detection Technology," November 13-15, 1991, p. 653.
36. J. Durup in Recent Developments in Mass Spectrometry, K. Ogata and T. Hayakawa (Eds.), pp. 921-934, University Park Press, Baltimore, MD (1970).
37. A.K. Shukla and J.H. Futrell, *Mass Spectrom. Rev.*, **12**, 211 (1993).
38. S.A. McLuckey, *J. Am. Soc. Mass Spectrom.*, **3**, 599 (1992).
39. R.G. Cooks, *J. Mass Spectrom.*, **30**, 1215 (1995).
40. D.D. Fetterolf and R.A. Yost, *Int. J. Mass Spectrom. Ion Proc.*, **62**, 33 (1984).
41. R.A. Yost and C.G. Enke, *J. Am. Chem. Soc.*, **100**, 2274 (1978).
42. R.A. Yost and C.G. Enke, *Anal. Chem.*, **51**, 1251A (1979).
43. G.L. Glish and S.A. McLuckey, *Anal. Instrum.*, **15**, 1 (1986).
44. J.D. Ciupek, J.W. Amy, R.G. Cooks, and A.E. Schoen, *Int. J. Mass Spectrom. Ion Proc.*, **65**, 141 (1985).
45. G.L. Glish and S.A. McLuckey, *Org. Mass Spectrom.*, **24**, 470 (1989).
46. S.A. McLuckey, G.L. Glish, and B.C. Grant, *Anal. Chem.*, **62**, 56 (1990).
47. T.A. Lehman and M.M. Bursey, "Ion Cyclotron Resonance Spectrometry," John Wiley and Sons, New York, NY, 1976.
48. R.E. March and R.J. Hughes, "Quadrupole Storage Mass Spectrometry," John Wiley and Sons, New York, NY, 1989.
49. M.B. Comisarow and A.G. Marshall, *Chem. Phys. Lett.*, **25**, 282 (1974).
50. B.S. Freiser in "Techniques for the Study of Ion-Molecule Reactions," J.M. Farrar and W.H. Saunders, Jr. (Eds.), John Wiley and Sons, New York, NY, 1988.
51. R.B. Cody, J.A. Kinsinger, S. Ghaderi, I.J. Amster, F.W. McLafferty, and C.G. Brown, *Anal. Chim. Acta*, **178**, 43 (1985).
52. C.L. Wilkins, A.K. Chowdhury, L.M. Nuwaysir, and M.L. Coates, *Mass Spectrom. Rev.*, **8**, 67 (1989).

53. A.G. Marshall and P.B. Grosshans, *Anal. Chem.*, **63**, 215A (1991).
54. G.C. Stafford, Jr., P.E. Kelley, and D.R. Stephens, U.S. Patent 4,540,884 (1985).
55. G.C. Stafford, Jr., P.E. Kelley, J.E.P. Syka, W.E. Reynolds, and J.F.J. Todd, *Int. J. Mass Spectrom. Ion Phys.*, **60**, 85 (1984).
56. S.A. McLuckey, D.E. Goeringer, and G.L. Glish, *J. Am. Soc. Mass Spectrom.*, **2**, 11 (1991).
57. J.N. Louris, R.G. Cooks, J.E.P. Syka, P.E. Kelley, G.C. Stafford, Jr., J.F.J. Todd, *Anal. Chem.*, **59**, 1677 (1987).
58. J.N. Louris, J.S. Brodbelt-Lustig, R.G. Cooks, G.L. Glish, G.J. Van Berkel, and S.A. McLuckey, *Int. J. Mass Spectrom. Ion Proc.*, **96**, 117 (1990).
59. S.A. McLuckey, G.L. Glish, and G.J. Van Berkel, *Int. J. Mass Spectrom. Ion Proc.*, **106**, 213 (1991).
60. D.W. Berberich and R.A. Yost, *J. Am. Soc. Mass Spectrom.*, **5**, 757 (1994).
61. S.A. McLuckey, G.L. Glish, and K.G. Asano, *Anal. Chim. Acta*, **225**, 25 (1989).
62. B.A. Eckenrode, G.L. Glish, and S.A. McLuckey, *Int. J. Mass Spectrom Ion Processes*, **99**, 151 (1990).
63. S.A. McLuckey, G.J. Van Berkel, D.E. Goeringer, G.L. Glish, *Anal. Chem.*, **66**, 689A (1994).
64. S.A. McLuckey, G.J. Van Berkel, D.E. Goeringer, G.L. Glish, *Anal. Chem.*, **66**, 737A (1994).
65. J.V. Johnson, R.A. Yost, P.E. Kelley and D.C. Bradford, *Anal. Chem.*, **62**, 2162 (1990).
66. S.A. McLuckey, G.L. Glish, and P.E. Kelley, *Anal. Chem.*, **59**, 1670 (1987).
67. M.J. Charles, S.A. McLuckey, and G.L. Glish, *J. Am. Soc. Mass Spectrom.*, **5**, 1031 (1994).
68. J. Gronowska, C. Paradisi, P. Traldi, and U. Vettori, *Rapid Commun. Mass Spectrom.*, **4**, 306 (1990).
69. R.E. March, F.A. Londry, R.L. Alfred, A.M. Franklin, and J.F.J. Todd, *Int. J. Mass Spectrom. Ion Processes*, **112**, 247 (1992).
70. K.J. Hart and S.A. McLuckey, *J. Am. Soc. Mass Spectrom.*, **5**, 250 (1994).

71. D.E. Goeringer and S.A. McLuckey, *J. Chem. Phys.*, 1996, In Press.
72. S.A. McLuckey and G.L. Glish, *Org. Mass Spectrom.*, **22**, 224 (1987).
73. M.L. Langford and J.F.J. Todd, "Practical Aspects of Ion Trap Mass Spectrometry, Volume III," R.E. March and J.F.J. Todd (Eds.), CRC Press, Boca Raton, FL, 1995, Chapter 10.
74. T.-C.L. Wang, T.L. Ricca, and A.G. Marshall, *Anal. Chem.*, **58**, 2935 (1986).
75. R.K. Julian, Jr., K.A. Cox, and R.G. Cooks, *Anal. Chem.*, **65**, 1827 (1993).
76. P. Kelley, D. Hoekman, and S. Bradshaw, "Proceedings of the 41st ASMS Conference on Mass Spectrometry and Allied Topics," May 31-June 4, 1993, San Francisco, CA, p. 453.
77. D.E. Goeringer, K.G. Asano, S.A. McLuckey, D. Hoekman, S.E. Stiller, *Anal. Chem.*, **66**, 313 (1994).
78. S.A. McLuckey, D.E. Goeringer, and G.L. Glish, *Anal. Chem.*, **64**, 1455 (1992).
79. N.A. Yates, M.M. Booth, J.L. Stephenson, Jr., and R.A. Yost, "Practical Aspects of Ion Trap Mass Spectrometry, Volume III," R.E. March and J.F.J. Todd (Eds.), CRC Press, Boca Raton, FL, 1995, Chapter 4.
80. M. Wang and G. Wells, "Proceedings of the 41st ASMS Conference on Mass Spectrometry and Allied Topics," May 31-June 4, 1993, San Francisco, CA, p. 463.
81. J. Franzen, *Int. J. Mass Spectrom. Ion Proc.*, **106**, 63 (1991).
82. J.N. Louris, J.C. Schwartz, G.C. Stafford, Jr., J.E.P. Syka, and D. Taylor, "Proceedings of the 40th ASMS Conference on Mass Spectrometry and Allied Topics," May 31-June 5, 1992, Washington, DC, p.1003.
83. K.G. Asano, D.E. Goeringer and S.A. McLuckey, *Anal. Chem.*, **67**, 2739 (1995).
84. R.E. Kaiser, Jr., R.G. Cooks, G.C. Stafford, Jr., J.E.P. Syka, P.H. Hemberger, *Int. J. Mass Spectrom. Ion Proc.*, **106**, 79 (1991).
85. J.C. Schwartz, J.E.P. Syka, and I. Jardine, *J. Am. Soc. Mass Spectrom.*, **2**, 198 (1991).

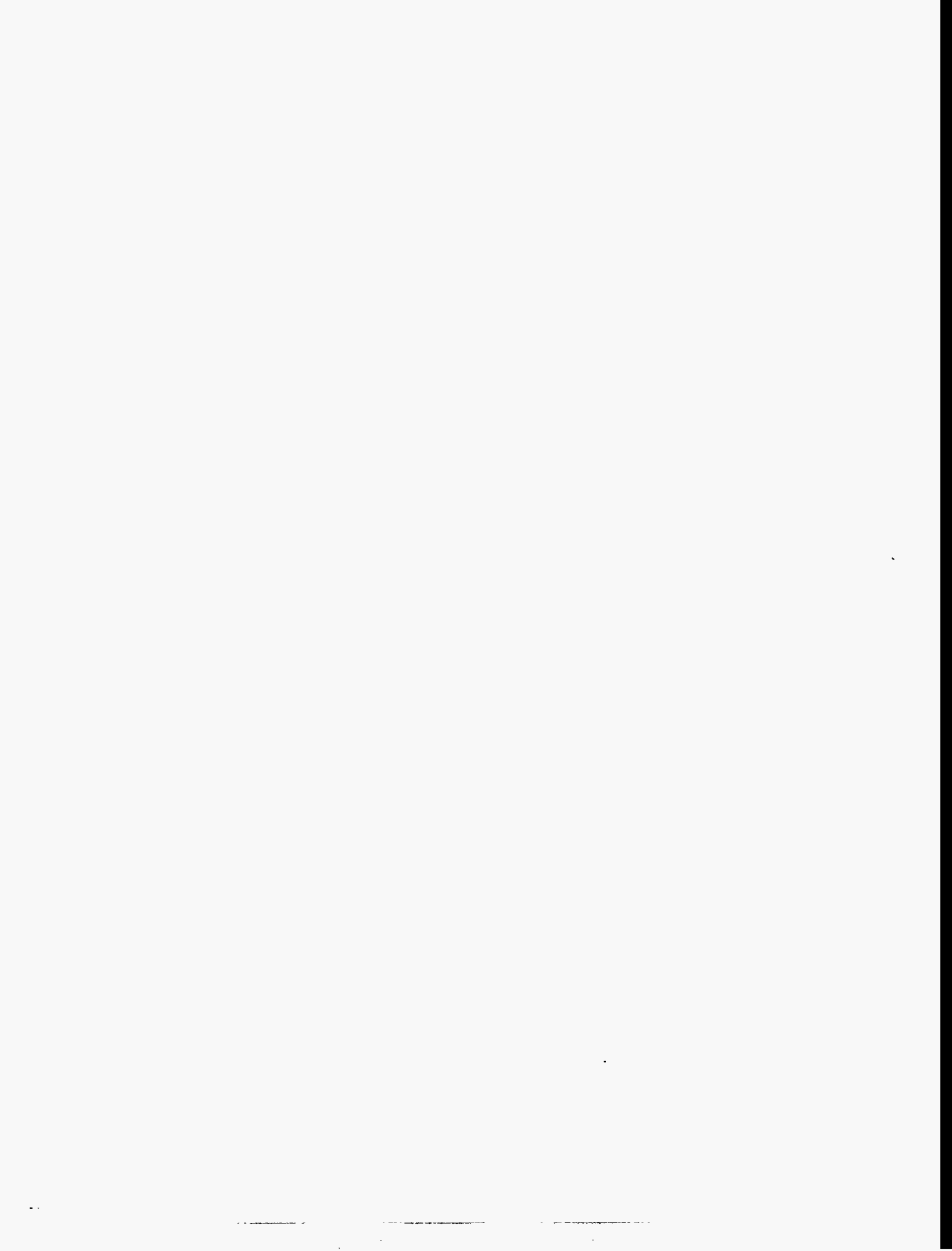

ACKNOWLEDGEMENTS

Several of our colleagues at ORNL have made major contributions at various stages to our explosives detection efforts. Particularly prominent long-term contributions have been made by Dr. Gary L. Glish, Dr. Joel A. Carter, Mr. Henry S. McKown, and Mr. Barry C. Grant. Important contributions to particular focus areas were made by Dr. Brian A. Eckenrode, Dr. Richard A. Flurer, Dr. David M. Chambers, Dr. Gary J. Van Berkel, Dr. Kevin J. Hart, Dr. Gopalakrishnan Vaidyanathan, and Dr. James L. Stephenson, Jr. We also acknowledge helpful discussions over a long-term period with Mr. Frank J. Conrad and Mr. David W. Hannum of Sandia National Laboratories. This work was supported by the United States Department of Energy, Office of Safeguards and Security. Oak Ridge National Laboratory is managed for the United States Department of Energy by Lockheed Martin Energy Research Corporation under Contract DE-AC05-96OR22464.

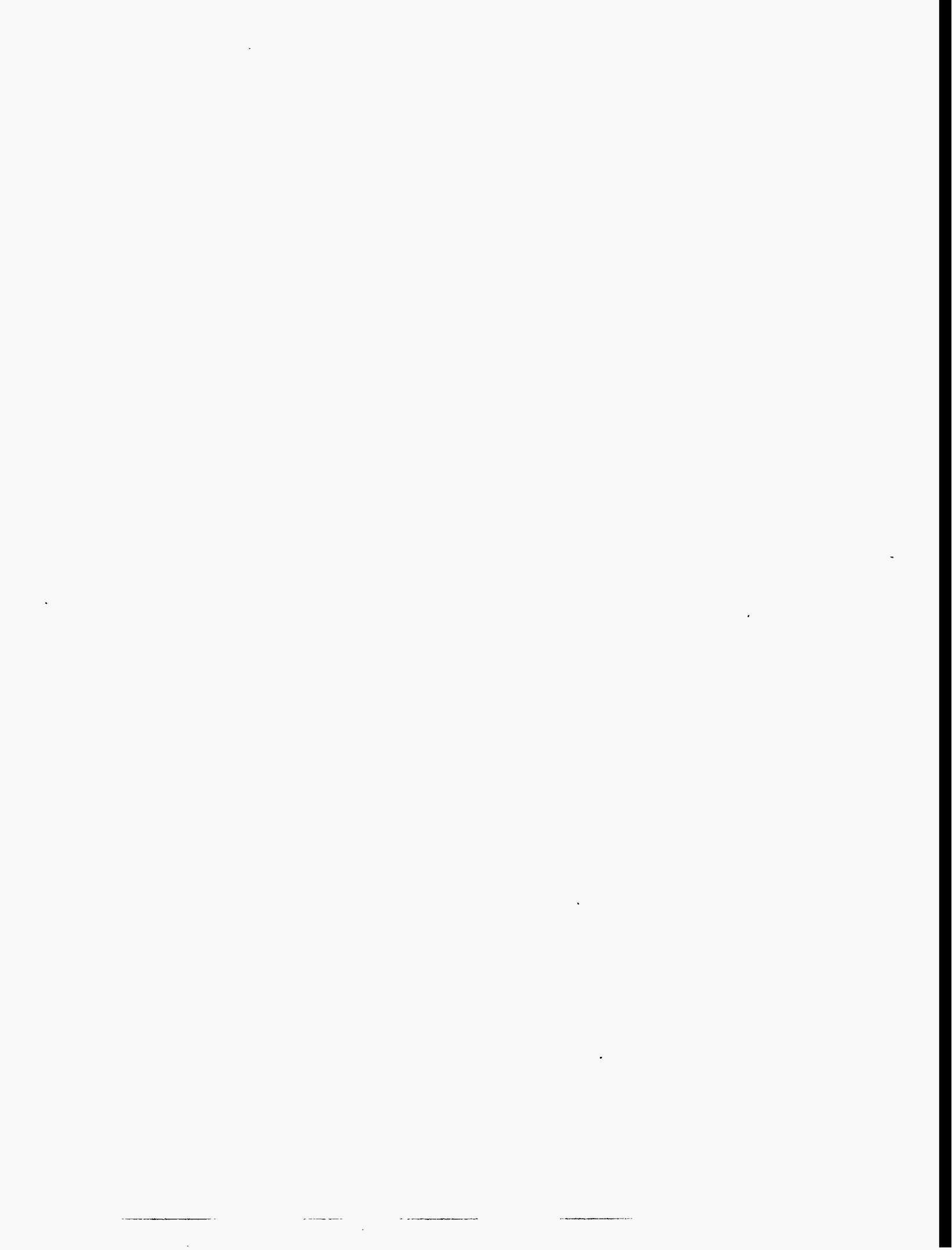

Appendix I

Titles of research papers resulting from OSS sponsorship

"High Explosives Vapor Detection by Glow Discharge/Ion Trap Mass Spectrometry."

Scott A. McLuckey, Douglas E. Goeringer, Keiji G. Asano, Gopalakrishnan Vaidyanathan, and James L. Stephenson, Jr., Rapid Communications in Mass Spectrometry, In press for a special issue devoted to mass spectrometry R&D at Oak Ridge National Laboratory.

"Parallel Monitoring for Multiple Targeted Compounds by Ion Trap Mass Spectrometry."

Keiji G. Asano, Douglas E. Goeringer, and Scott A. McLuckey, Analytical Chemistry, 67 (1995) 2739-2742.

"Ion Trap Mass Spectrometry of Externally Generated Ions."

Scott A. McLuckey, Gary J. Van Berkel, Douglas E. Goeringer, and Gary L. Glish, Analytical Chemistry, 66 (1994) 689A-696A.

"Ion Trap Mass Spectrometry Using High Pressure Ionization."

Scott A. McLuckey, Gary J. Van Berkel, Douglas E. Goeringer, and Gary L. Glish, Analytical Chemistry, 66, (1994) 737A-743A.

"Filtered-Noise-Field Signals for Mass-Selective Accumulation of Externally Formed Ions in a Quadrupole Ion Trap."

Douglas E. Goeringer, Keiji G. Asano, Scott A. McLuckey, Don Hoekman, and Steven E. Stiller, Analytical Chemistry, 66, (1994), 313-318.

"Role of Gas Dynamics in Negative Ion Formation in an Atmospheric Sampling Glow Discharge Ionization Source."

David M. Chambers, Scott A. McLuckey, and Gary L. Glish, Analytical Chemistry, 65 (1993) 778-783.

"Collisional Activation with Random Noise in Ion Trap Mass Spectrometry."

Scott A. McLuckey, Douglas E. Goeringer, and Gary L. Glish, Analytical Chemistry, 64 (1992) 1455.

"Selective Ion Isolation/Rejection Over a Broad Mass Range in the Quadrupole Ion Trap."

Scott A. McLuckey, Douglas E. Goeringer, and Gary L. Glish, Journal of the American Society for Mass Spectrometry, 2 (1991) 11.

"Simultaneous Monitoring for Parent Ions of Specified Daughter Ions: A Method for Rapid Screening Using Mass Spectrometry/Mass Spectrometry."

Scott A. McLuckey, Barry C. Grant, and Gary L. Glish, Analytical Chemistry, 62 (1990) 56.

"Explosives Detection with an Ion Trap Mass Spectrometer."

Scott A. McLuckey, Gary L. Glish, and Barry C. Grant, "Proceedings of the Third Symposium on Analysis and Detection of Explosives," Mannheim-Neuostheim, FRG, July 10-13, 1989.

"Evaluation of the Oak Ridge MS/MS Explosives Detector."

Frank J. Conrad, David W. Hannum, Barry C. Grant, Scott A. McLuckey, Henry S. McKown, and Gary L. Glish, "Proceedings of the Third Symposium on Analysis and Detection of Explosives," Mannheim-Neuostheim, FRG, July 10-13, 1989.

"Improved Performance of a Tandem Quadrupole/Time-of-Flight Mass Spectrometer."

Gary L. Glish, Scott A. McLuckey, and Henry S. McKown, Analytical Instrumentation, 16 (1987) 191.

"A Tandem Mass Spectrometer for the Detection of Nitroaromatic Compounds and Other Electronegative Species in Ambient Air."

Gary L. Glish, Scott A. McLuckey, and Henry S. McKown, in "Analytical Chemistry Instrumentation," W.R. Laing (Ed.), Lewis Publishers, Inc., Chelsea, MI, 1986, p.33.

"The Analysis of Explosives by Tandem Mass Spectrometry."

Scott A. McLuckey, Gary L. Glish, and Joel A. Carter, Journal of Forensic Sciences, 30 (1985) 773.

"Developments in Explosives Vapor Detection by Glow Discharge/Ion Trap MS."

Keiji Asano, Gopalakrishanan Vaidyanathan, Douglas Goeringer, and Scott McLuckey, "Proceedings of the 43rd ASMS Conference on Mass Spectrometry and Allied Topics," Atlanta, GA, May 21-26, 1995, p.1140.

"Pressure and Residence Time Effects in Atmospheric Sampling Glow Discharge."

Keiji G. Asano, Douglas E. Goeringer, and Scott A. McLuckey, "Proceedings of the 42nd ASMS Conference on Mass Spectrometry and Allied Topics," Chicago, IL, May 29-June 3, 1994, p. 749.

"Mass-selective Ion Accumulation in the Ion Trap: Ion Injection using Filtered-Noise Fields."

Keiji G. Asano, Douglas E. Goeringer, and Scott A. McLuckey, "Proceedings of the 41st ASMS Conference on Mass Spectrometry and Allied Topics," San Francisco, CA, May 31-June 4, 1993, p.700.

"MS" in the Quadrupole Ion Trap Using Filtered-Noise Fields."

Douglas E. Goeringer, Keiji G. Asano, and Scott A. McLuckey, "Proceedings of the 41st ASMS Conference on Mass Spectrometry and Allied Topics," San Francisco, CA, May 31-June 4, 1993, p.930.

"Universal Collisional Activation in Ion Trap Mass Spectrometry."

Scott A. McLuckey, Douglas E. Goeringer, and Gary L. Glish, "Proceedings of the 40th ASMS Conference on Mass Spectrometry and Allied Topics," Washington, DC, May 31-June 5, 1992, p.1013.

"Atmospheric Sampling Glow Discharge Ionization: Time-Resolved Studies with a Pulsed Discharge."

Barry C. Grant, Scott A. McLuckey, and Gary L. Glish, "Proceedings of the 38th ASMS Conference on Mass Spectrometry and Allied Topics," Tucson, AZ, June 3-8, 1990, p.195.

"Tactics for Selective Ion Storage/Rejection Over a Broad Mass Range in the Three-Dimensional Quadrupole Ion Trap."

Barry C. Grant, Scott A. McLuckey, and Gary L. Glish, "Proceedings of the 38th ASMS Conference on Mass Spectrometry and Allied Topics," Tucson, AZ, June 3-8, 1990, p.57.

"The Role of Mass Spectrometry in the Analysis of Explosives."

Scott A. McLuckey and Gary L. Glish, "Proceedings of the 37th ASMS Conference on Mass Spectrometry and Allied Topics," Miami Beach, FL, May 21-26, 1989, p.806.

"Improved Performance of a Tandem Quadrupole/Time-of-Flight Mass Spectrometer."

Gary L. Glish, Scott A. McLuckey, and Henry S. McKown, "Proceedings of the 36th ASMS Conference on Mass Spectrometry and Allied Topics," Cincinnati, OH, June 8-13, 1986, p.768.

"Mass Spectrometry/Mass Spectrometry Applied to the Detection of Explosives; Background, Progress Report for FY 1984 and Future Plans."

Scott A. McLuckey, Gary L. Glish, and Joel A. Carter, ORNL/TM-9447, January, 1985.

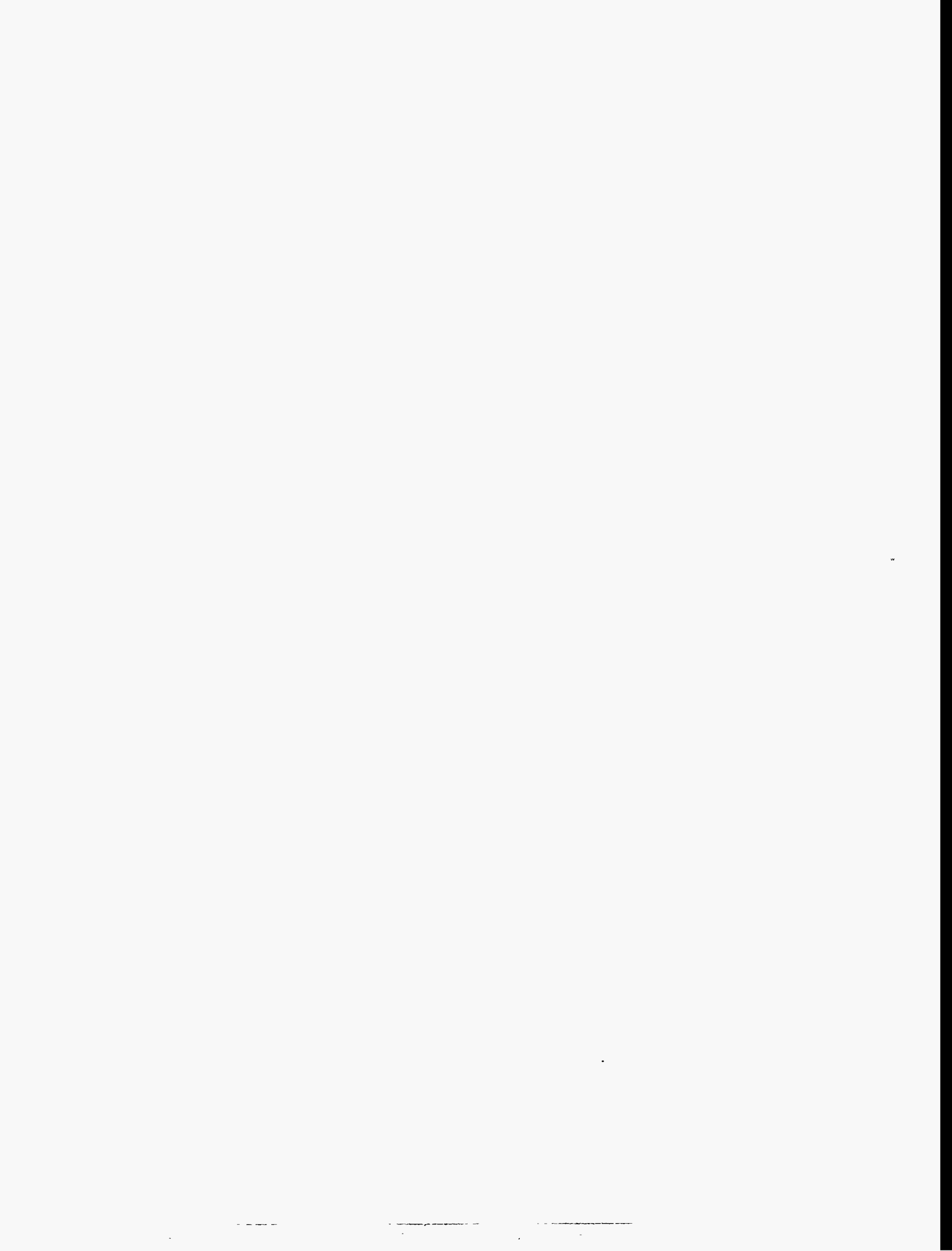

Appendix II

U.S. Patent 5,206,509 resulting from OSS sponsorship

United States Patent [19]

[11] Patent Number: 5,206,509

McLuckey et al.

[45] Date of Patent: Apr. 27, 1993

[54] UNIVERSAL COLLISIONAL ACTIVATION ION TRAP MASS SPECTROMETRY

[75] Inventors: Scott A. McLuckey; Douglas E. Goeringer; Gary L. Glish, all of Oak Ridge, Tenn.

[73] Assignee: Martin Marietta Energy Systems, Inc., Oak Ridge, Tenn.

[21] Appl. No.: 805,442

[22] Filed: Dec. 11, 1991

[51] Int. Cl.⁵ B01D 59/44; H01J 49/00

[52] U.S. Cl. 250/292; 250/282

[58] Field of Search 250/281, 282, 291, 292

[56] References Cited

U.S. PATENT DOCUMENTS

4,686,367	8/1987	Louris et al.	250/291
4,736,101	4/1988	Syka et al.	250/292
4,749,860	6/1988	Kelly et al.	250/282
4,755,670	7/1988	Syka et al.	250/292
4,945,234	7/1990	Goodman et al.	250/292

OTHER PUBLICATIONS

J. E. Fulford et al., "Radio-Frequency Mass-Selective Excitation & Resonant Ejection of Ions in a Three-Dimensional Quadrupole Ion Trap," *Journal of Vacuum Science and Technology*, 17(4), 829 (1980).

R. B. Cody et al., "Collision-Induced Dissociation with Fourier Transform Mass Spectrometry," *Analytical Chemistry*, 54, 96 (1982).

J. N. Louris et al., "Instrumentation, Applications &

Energy Deposition in Quadrupole Ion Trap Tandem Mass Spectrometry," *Anal. Chem.*, 59, 1677 (1987).

N. A. Yates et al., "Resonant Excitation for GC/MS/MS in the Quadrupole Ion Trap via Frequency Assignment Pre-Scans and Broadband Excitation," *Proceedings of the 39th ASMS Conf. on Mass Spec. & App. Topics*, May 1991, Nashville, Tenn., p. 132.

C. F. Ijames, et al., "Fourier Transform Mass Spectrometry Using Random-Noise Excitation," *Chemical Physics Letters*, 108, 58 (1984).

S. A. McLuckey et al., "Simultaneous Monitoring for Parent Ions of Targeted Product Ions: A Method for Rapid Screening Using Mass Spectrometry/Mass Spectrometry," *Analytical Chemistry*, 62, 56 (1990).

Primary Examiner—Bruce C. Anderson

Attorney, Agent, or Firm—Joseph A. Marasco; Harold W. Adams

[57]

ABSTRACT

A universal collisional activation ion trap comprises an ion trapping means containing a bath gas and having connected thereto a noise signal generator. A method of operating a universal collisional activation ion trap comprises the steps of: providing an ion trapping means; introducing into the ion trapping means a bath gas; and, generating a noise signal within the ion trapping means; introducing into the ion trapping means a substance that, when acted upon by the noise signal, undergoes collisional activation to form product ions.

18 Claims, 9 Drawing Sheets

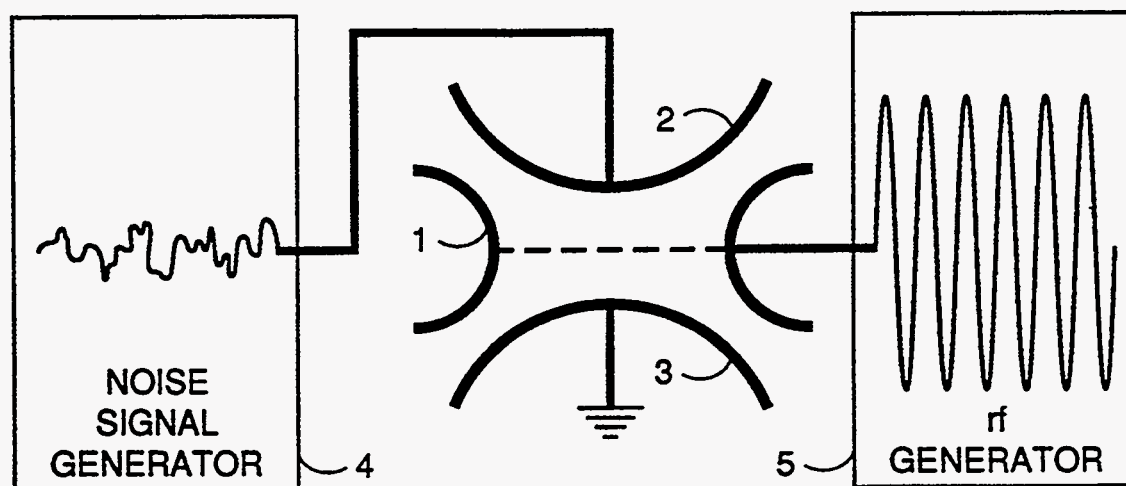

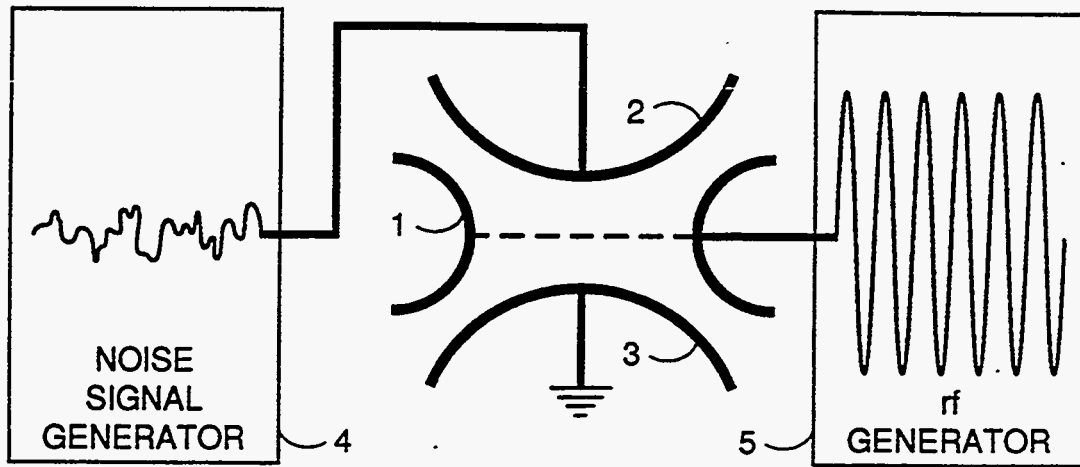

Fig. 1

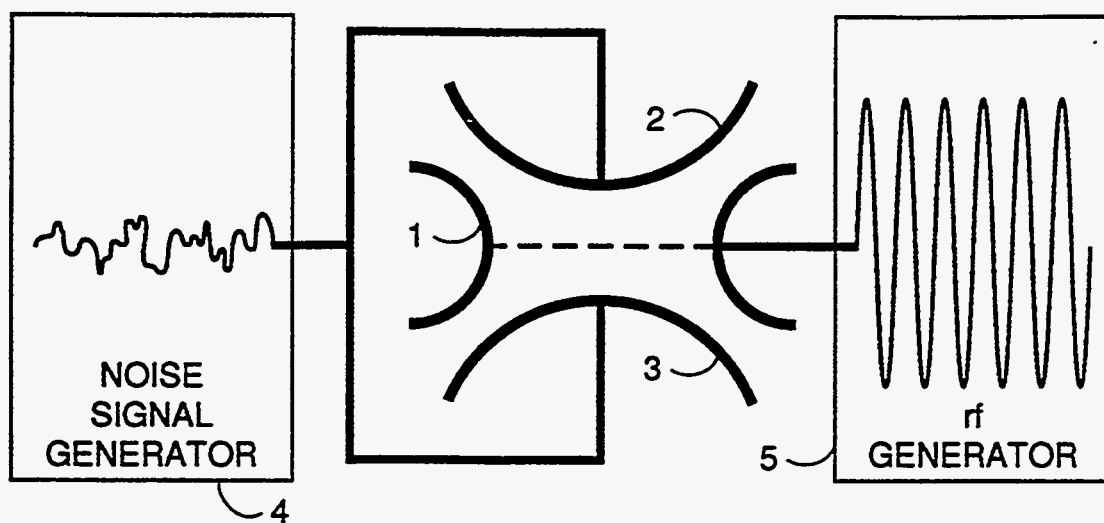

Fig. 2

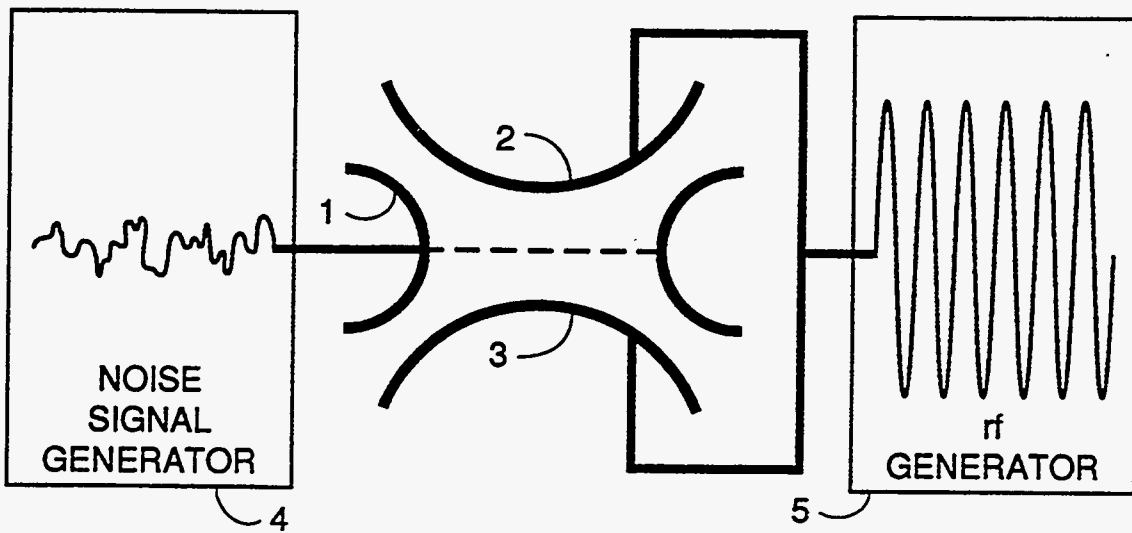

Fig. 3

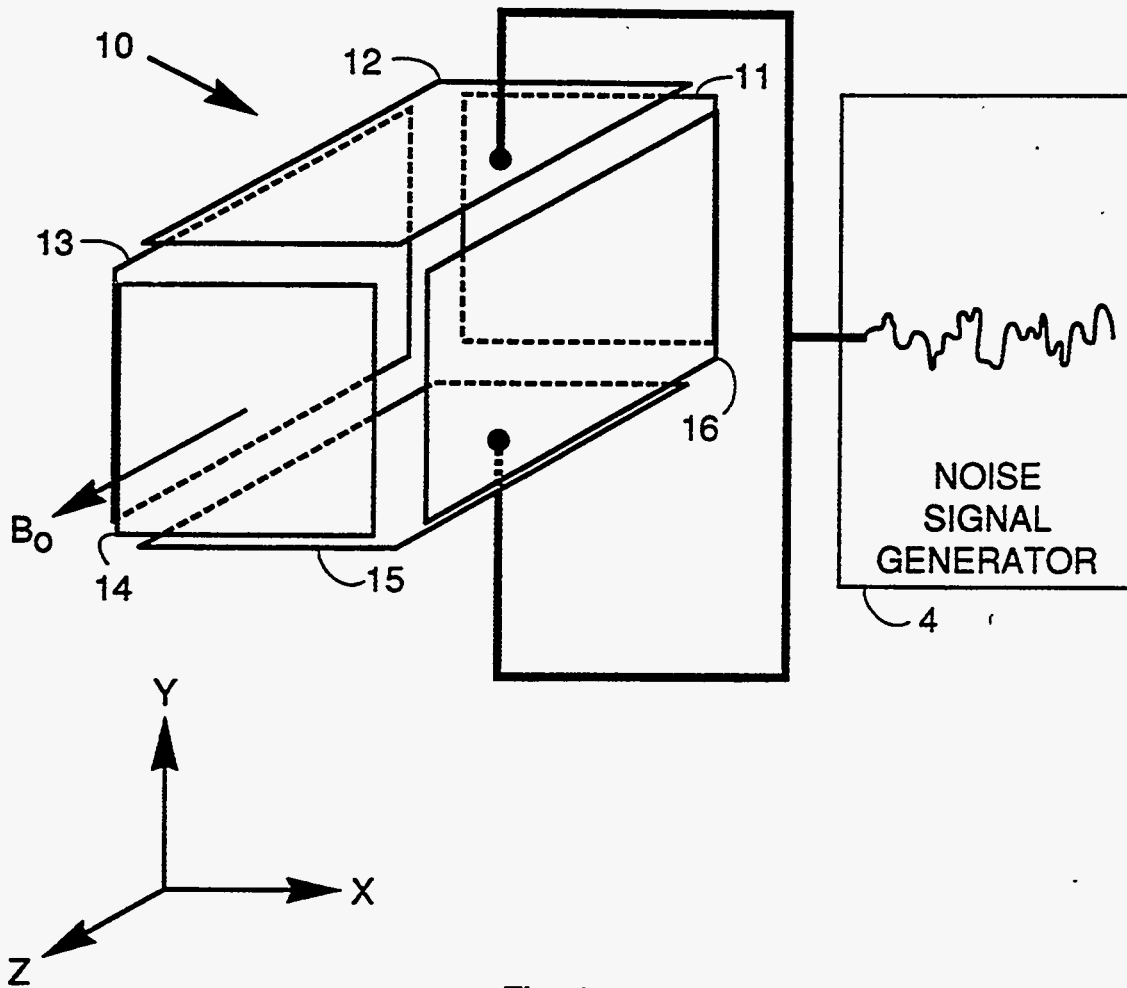

Fig. 4

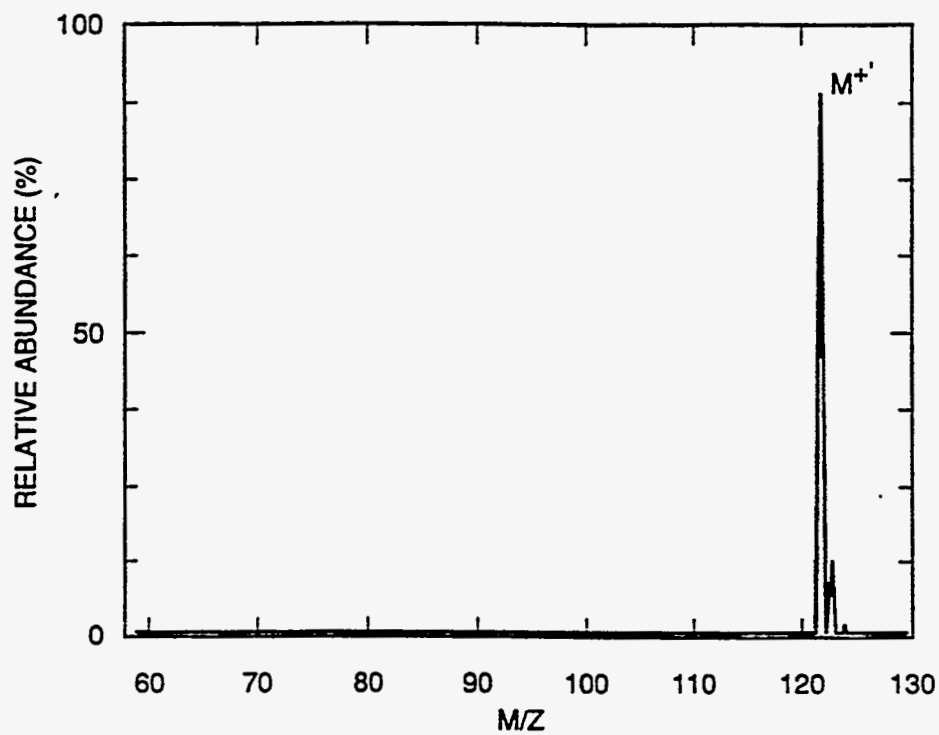

Fig. 5a

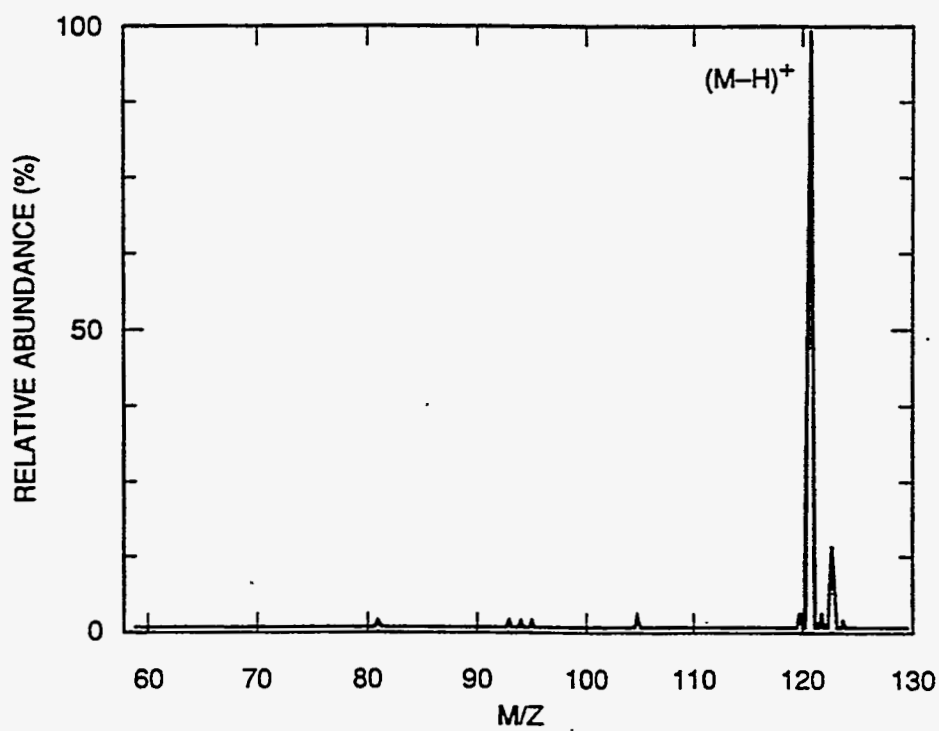

Fig. 5b

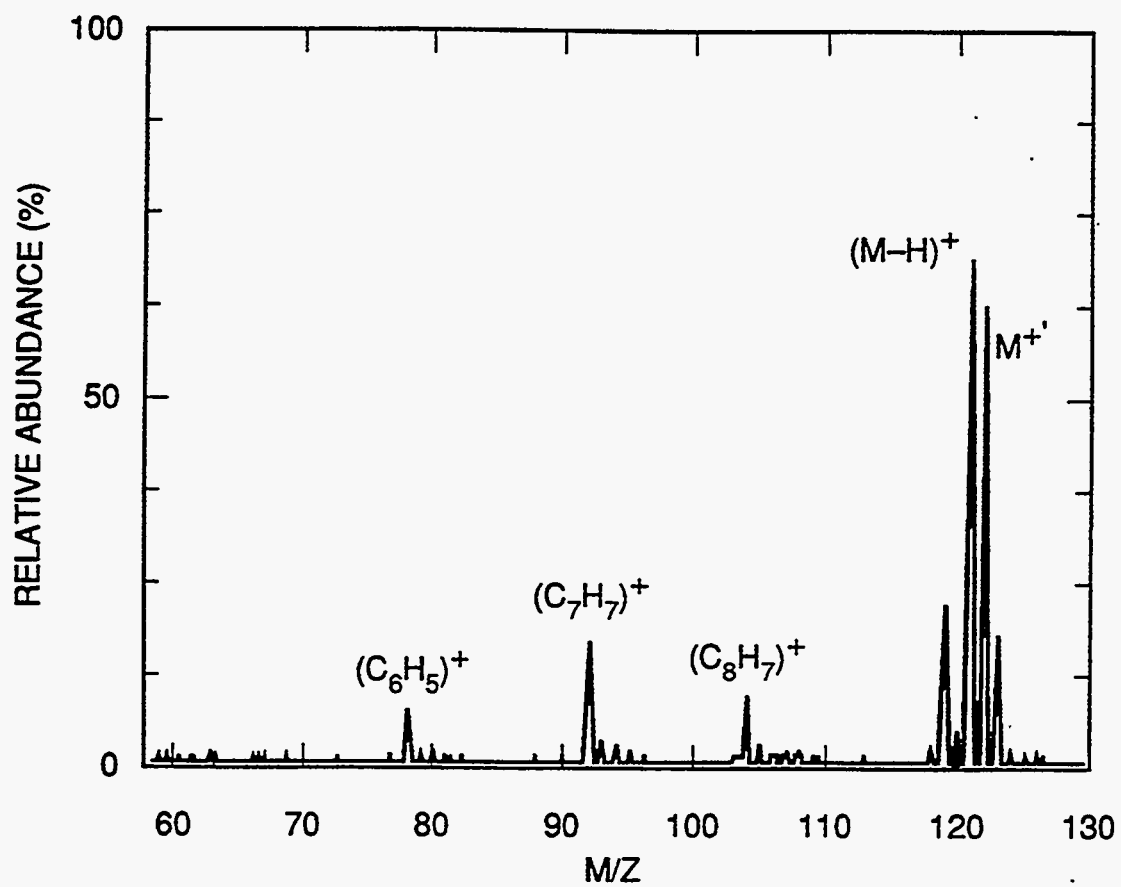

Fig. 5c

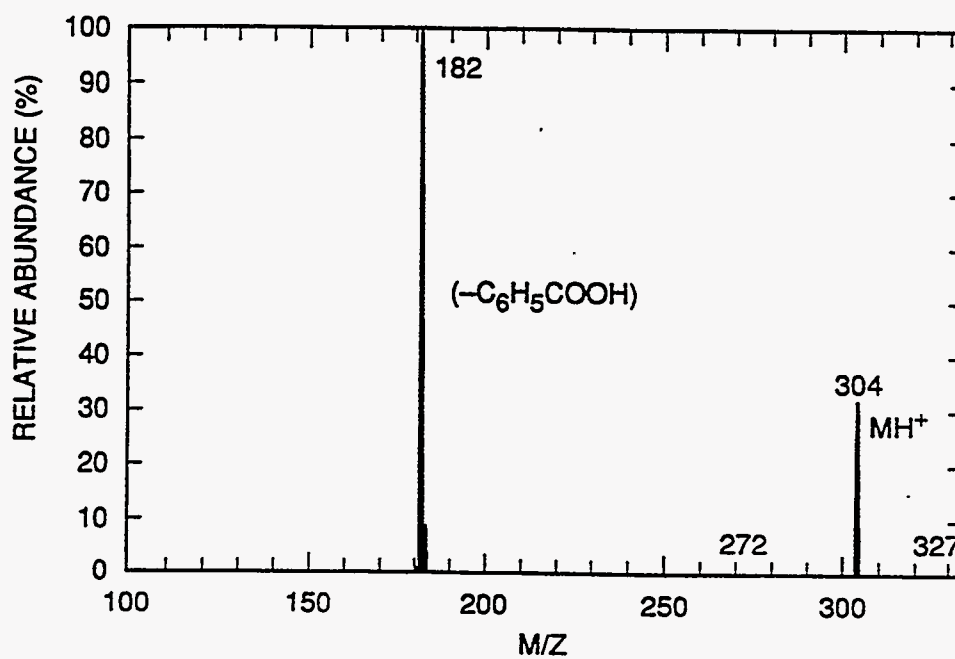

Fig. 6a

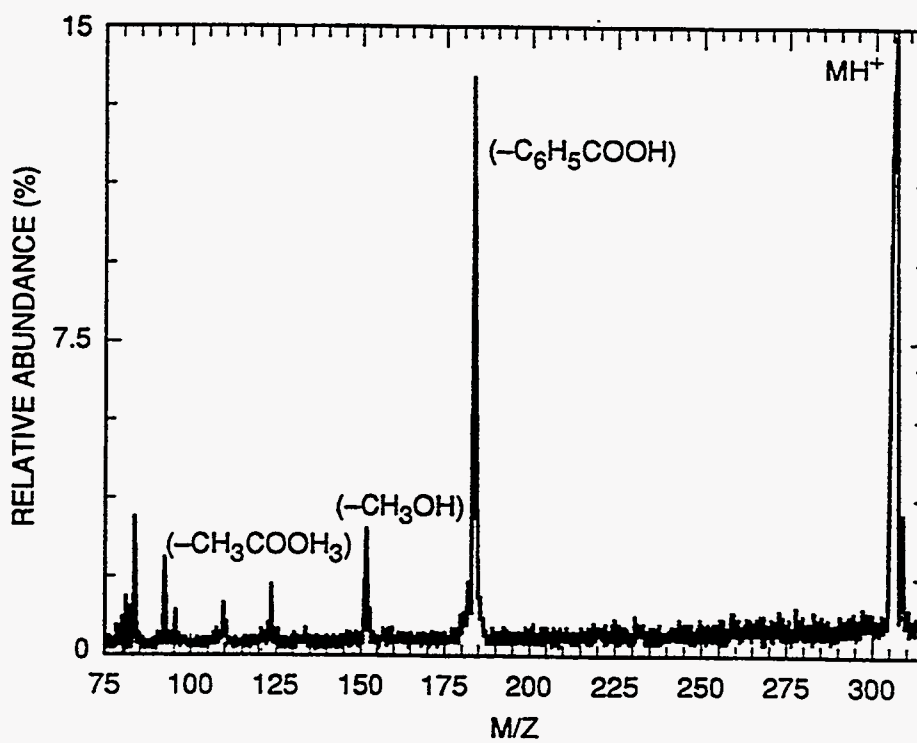

Fig. 6b

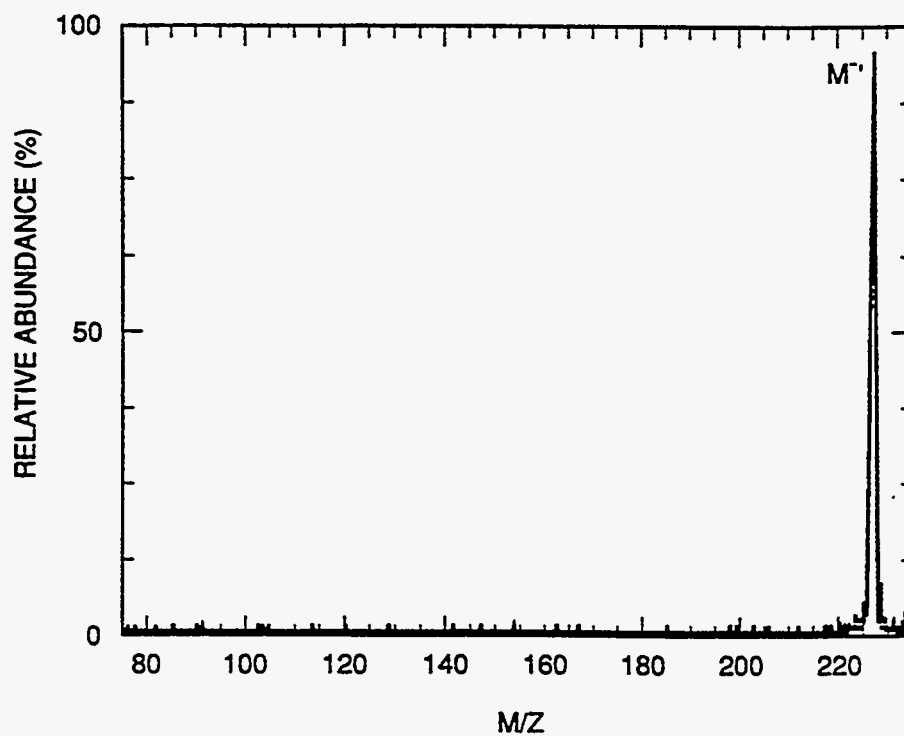

Fig. 7a

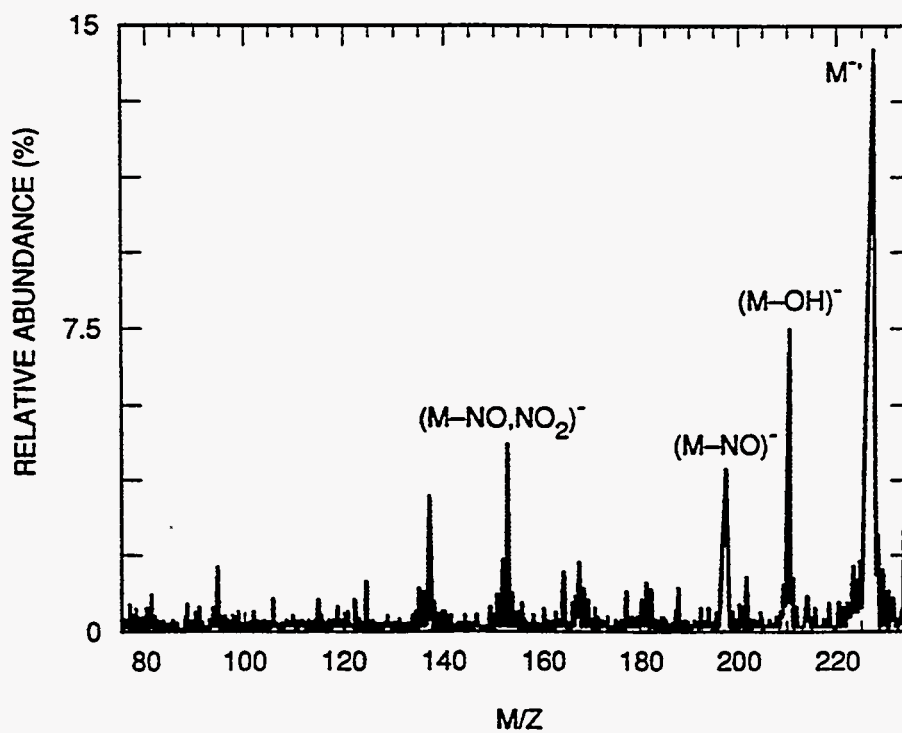

Fig. 7b

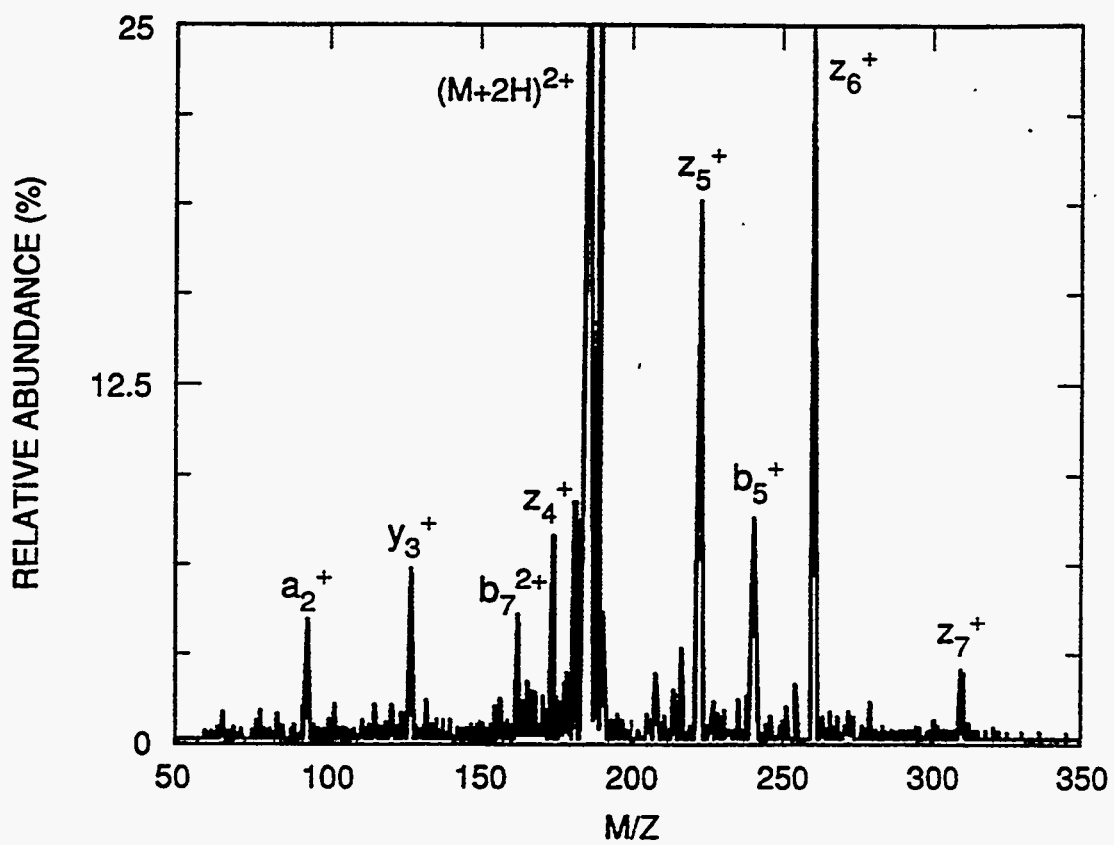

Fig. 8

UNIVERSAL COLLISIONAL ACTIVATION ION TRAP MASS SPECTROMETRY

The U.S. Government has rights in this invention pursuant to contract no. DE-AC05-84OR21400 between the U.S. Department of Energy and Martin Marietta Energy Systems, Inc., and funded by the Office of Safeguards and Security.

FIELD OF THE INVENTION

The present invention relates to collisional activation ion trapping instruments and methods of using same, and more particularly to universal collisional activation ion trap mass spectrometers and methods of using same.

BACKGROUND OF THE INVENTION

Deliberate dissociation of ions via collision-induced dissociation (CID) is a useful technique for verification of molecular entities in mass spectrometers including those based on ion trapping. Collisional activation (CA), which constitutes the first step of CID (dissociation being the second step), can be effected in ion trapping instruments by resonantly exciting ions at one or more of their characteristic frequencies of motion within the trapping field.

Because the frequencies of ion motion are mass-to-charge dependent, the use of a single excitation frequency makes collisional activation in ion trapping instruments mass-to-charge specific. Consequently, a priori knowledge of the mass-to-charge ratio for a selected ion has been required in order that the excitation frequency can be correctly adjusted. Furthermore, the frequencies of ion motion are affected by the presence of other ions of like charge (i.e., space charge) which limits the usefulness of the single frequency excitation methods commonly used in conventional ion trapping instruments.

Single frequency excitation methods as used in ion traps employ a discrete, precisely-tuned frequency to excite a limited number of ions possessing a particular mass-to-charge ratio. Also, in many conventional ion trapping applications, the number of ions is difficult to control which necessitates frequency adjustments that are generally tedious and time-consuming. Furthermore, the extent of fragmentation, which provides structural information, is often limited because once the parent ion becomes fragmented, the first generation product ions fall out of resonance and typically do not undergo further fragmentation. Further background information can be found in the following references, all of which are incorporated herein by reference: J. E. Fulford, et al., "Radio-frequency mass-selective excitation and resonant ejection of ions in a three-dimensional quadrupole ion trap", *Journal of Vacuum Science and Technology*, 17(4), 829 (1980); R. B. Cody, et al., "Collision-Induced Dissociation with Fourier Transform Mass Spectrometry", *Analytical Chemistry*, 54, 96(1982); J. N. Louris, et al., "Instrumentation, Applications and Energy Deposition in Quadrupole Ion Trap Tandem Mass Spectrometry", *Analytical Chemistry*, 59, 1677 (1987); and Syka, et al. "Method of Operating Ion Trap Detector in MS/MS Mode", U.S. Pat. No. 4,736,101.

Yates et al. have described the use of rapid frequency pre-scans over a narrow mass range (1.7 amu) to determine empirically the parent ion resonant frequency in an automated fashion. These workers have also de-

scribed the use of a supplementary signal with a range in frequency of 10 kHz, equivalent to a mass/charge range of 1.7 at a q_z value of 0.3. Both approaches were found to deal effectively with the space charge problem but neither deals with the problems of limited fragmentation and inability to fragment ions simultaneously over a range of mass/charge values. Further information can be found in N. A. Yates et al., "Resonant Excitation for GC/MS/MS in the Quadrupole Ion Trap via Frequency Assignment Pre-Scans and Broadband Excitation," *Proceedings of the 39th ASMS Conference on Mass Spectrometry and Applied Topics*, May 1991, Nashville, Tenn., p. 132.

Random-noise excitation has been used in Fourier transform ion cyclotron resonance mass spectrometry as part of the final detection/mass analysis step, but not as a means for inducing fragmentation of ions. Random noise was used to kinetically excite all ions in the ion cyclotron resonance mass spectrometer to higher orbits in order to allow their detection by the image currents they induce in receiver plates. In such an application, vacuum conditions are necessary; collisions with background or bath gases have a pernicious effect upon the detection method. Further information can be found in C. F. Ijames, et al., "Fourier Transform Mass Spectrometry Using Random-Noise Excitation", *Chemical Physics Letters*, 108, 58 (1984).

Non-selective collisional activation was used in the rapid screening technique described in S. A. McLuckey, et al., "Simultaneous Monitoring for Parent Ions of Targeted Product Ions: A Method for Rapid Screening Using Mass Spectrometry/Mass Spectrometry", *Analytical Chemistry*, 62, 56 (1990), which is incorporated herein by reference. The experiments reported therein were carried out with a non-trapping instrument and illustrate the usefulness of non-selective, universal collisional activation.

There is a need for apparatus and a method for collisional activation ion trapping which overcomes the problem of frequency shifts due to space charge and enables simultaneous kinetic excitation of trapped ions having a wide range of mass-to-charge ratios. There is also a need for apparatus and a method for collisional activation ion trap mass spectrometry wherein CID can be performed in a universal manner without time-consuming frequency adjustments.

OBJECTS OF THE INVENTION

Accordingly, it is an object of the present invention to provide a new and improved apparatus and method for collisional activation ion trap mass spectrometry which overcomes the problem of frequency shifts due to space charge and enables simultaneous kinetic excitation of trapped ions having a wide range of mass-to-charge ratios.

It is another object of the present invention to provide a new and improved apparatus and method for collisional activation ion trap mass spectrometry wherein CID can be performed in a universal manner without time-consuming frequency adjustments.

Further and other objects of the present invention will become apparent from the description contained herein.

SUMMARY OF THE INVENTION

In accordance with one aspect of the present invention, the foregoing and other objects are achieved by a universal collisional activation ion trap which com-

prises an ion trapping means having connected thereto a noise signal generator, the ion trapping means containing a bath gas.

In accordance with another aspect of the present invention, a universal collisional activation ion trap comprises a quadrupole ion trap containing a bath gas, a noise signal generator connected to the quadrupole ion trap for generating a noise signal within the the quadrupole ion trap.

In accordance with a further aspect of the present invention, a method of operating a universal collisional activation ion trap comprises the steps of:

- (a) providing an ion trapping means;
- (b) introducing into the ion trapping means a bath gas; and,
- (c) generating a noise signal within the ion trapping means to effect collisional activation of ions trapped therein.

BRIEF DESCRIPTION OF THE DRAWING

In the drawing:

FIG. 1 is a schematic representation of the subject apparatus wherein the noise signal is applied to one end-cap electrode of a quadrupole ion trap.

FIG. 2 is a schematic representation of the subject apparatus wherein the noise signal is applied to both end-cap electrodes of a quadrupole ion trap.

FIG. 3 is a schematic representation of the subject apparatus wherein the noise signal is applied to the ring electrode of a quadrupole ion trap.

FIG. 4 is a schematic representation of the subject apparatus wherein the noise signal is applied to opposing plates of an ion cyclotron resonance cell.

FIG. 5a shows the mass spectrum of the isolated radical cation of N,N-dimethylaniline, with no activation applied.

FIG. 5b shows the mass spectrum of the same compound resulting from the use of a conventional single frequency activation method.

FIG. 5c shows the spectrum of the same compound acquired according to the present invention.

FIG. 6a shows the mass spectrum of cocaine acquired using the conventional approach to collisional activation.

FIG. 6b shows the mass spectrum of cocaine acquired according to the present invention.

FIG. 7a shows the mass spectrum of the isolated molecular anion of 2,4,6-trinitrotoluene, with no activation applied.

FIG. 7b shows the mass spectrum of the same compound acquired according to the present invention.

FIG. 8 shows the mass spectrum of the doubly protonated peptide neuromedin U-8 acquired according to the present invention.

For a better understanding of the present invention, together with other and further objects, advantages and capabilities thereof, reference is made to the following disclosure and appended claims in connection with the above-described drawings.

DETAILED DESCRIPTION OF THE INVENTION

The invention described herein is effective for any ion trapping type of instrument in which ions execute periodic motion. This includes, but is not limited to, known devices such as multi-pole electrodynamic ion traps, e.g. quadrupole ion traps, and combined magnetic and electrostatic ion traps, e.g. ion cyclotron resonance

spectrometer. Other and varying embodiments of the apparatus and method are possible for other types of ion traps, all of which fall within the scope of the present invention.

Quadrupole ion traps are well known. Referring to FIG. 1, an ion trap is generally comprised of a center ring electrode 1 and two end-cap electrodes 2,3. To effect universal CID in a monopolar excitation mode, a noise signal generator 4 is connected to one end-cap electrode 2, the other end-cap electrode 3 being grounded. A radio-frequency (rf) generator 5 is connected to the ring electrode to supply the ion trap radio-frequency drive voltage which provides the alternating quadrupole field necessary for ion trapping. Referring now to FIG. 2, the noise signal generator can also be connected to both end-cap electrodes 2, 3, allowing the noise signal to be generated in-phase for quadrupolar excitation, or 180° out-of-phase for dipolar excitation. The configurations shown in FIGS. 1 and 2 will result in axial modulation.

In another embodiment of the invention, not illustrated, the noise signal can be applied to the ring electrode, along with the main ion trapping voltage. In this configuration, radial modulation and excitation will be achieved.

In another embodiment of the invention, shown in FIG. 3, The main trapping voltage can also be applied to the end-cap electrodes 2, 3 while the noise signal is connected to the ring electrode 1. In this configuration, monopolar excitation and radial modulation will be achieved.

A further embodiment of the invention is shown in FIG. 4. An ion cyclotron resonance cell 10 is typically comprised of six plates 11-16 defining a box shape which is located within a magnetic field, B_0 . The magnetic field, B_0 , confines ions in the x-y plane and electrostatic trapping plates confine ions in the z-direction. Universal collisional activation can be effected by applying noise 180° out-of-phase to either set of opposing plates which define the x-y plane. Kinetic excitation by noise can also be effected by application to the z-direction trapping plates.

Having described the preferred embodiments of the apparatus, a preferred method for universal collisional activation of ions in an ion trapping instrument will now be set forth.

Ions are accumulated in the ion trap either by injection or by direct formation within the ion trapping volume. Ions of a single mass-to-charge or a wide range of mass-to-charge independent of ion number are kinetically excited by a random-noise modulation signal applied to one or more electrodes comprising the ion trap. Because such a modulation signal has a continuous, wide-band frequency spectrum, the entire mass-to-charge range of the trapped ions undergoes simultaneous, nonspecific kinetic excitation. The amplitude of the noise signal is sufficient to cause ions to experience energetic collisions with the bath, or background gas in the ion trap while remaining in the trapping field.

The trapped ions absorb power and undergo energetic collisions with the bath gas. Collisions with the bath gas serve as a mechanism for power dissipation. Some of the absorbed power goes into increasing the kinetic energy of the bath gas atoms or molecules that undergo collision and some energy goes into internal modes of the ion, if it is polyatomic. The ions are thereby internally heated until they undergo dissociation and produce fragments, or product ions. The prod-

5

uct ions become resonant and undergo kinetic excitation and heating and may then also undergo further, or secondary dissociation. Successive generations of dissociation may continue.

Important experimental variables that will determine the appropriate power and duration of the noise signal are the strength of the trapping field, the pressure of the bath gas, and the propensity of the analyte ion for fragmentation. The optimum values for these variables for a particular analyte can be determined by routine experimentation.

Following the dissociation process, the noise signal is terminated and a mass spectrum is acquired by one of a variety of conventional means. The final spectrum then may show ions that survived the collisional activation process, first generation product ions, and successive generations of product ions.

The invention enables simultaneous kinetic excitation of stored ions having multiple, unidentified mass-to-charge ratios and a wide range of number densities (space charge). Thus, collisional activation can be effected in a non-selective manner without regard to ion number density and without prior knowledge of the parent ion mass-to-charge ratio. Parent and product ions are always "in resonance" so that more extensive fragmentation is typically observed without recourse to multiple single frequency excitation steps and the concomitant tuning.

The invention is especially beneficial when implemented with a quadrupole ion trap in monopolar, dipolar, quadrupolar, and radial modulation modes. The invention is useful as a means for including fragmentation of a wide variety of ions, independent of mass and ion number, particularly for analytical applications of ion trap mass spectrometers. This is a rapidly growing field which has already extended to environmental and biological analyses. The invention facilitates rapid analysis of samples with components not previously identified. Potential applications of interest include explosives detection, drug detection, and rapid environmental analysis of organic and other polyatomic species. The following examples are intended to illustrate the wide applicability of the method.

EXAMPLE I

N,N-dimethylaniline, a compound typical of many of environmental interest, was analyzed according to the present invention. FIG. 5a shows the spectrum of the isolated radical cation of N,N-dimethylaniline. FIG. 5b shows the spectrum resulting from the conventional single frequency method for collisional activation in ion traps. Note that the parent ion shows only one product ion corresponding to the loss of a hydrogen atom. The rationale behind using collisional activation is usually to produce a spectrum that allows unambiguous identification of the compound. The loss of a hydrogen atom is not particularly informative in this regard. FIG. 5c shows the spectrum after a 20 V p-p random noise signal was applied to the ion trap for 40 milliseconds prior to spectrum acquisition. Note that a variety of product ions are formed that would allow for identification from a library search. The latter spectrum is more informative than the former due to the fact that the first generation product ion also falls into resonance with the universal method whereas it falls out of resonance with the conventional method.

6

EXAMPLE II

Cocaine, a well known drug, was analyzed according to the present invention. FIG. 6 illustrates the behavior of a protonated molecule, cocaine, formed by chemical ionization. This compound is obviously of interest for drug detection and identification. FIG. 6a shows the spectrum acquired using the conventional approach to collisional activation (viz., single frequency excitation to match the frequency of roughly 10^4 ions of mass-to-charge 304). Note that the only product ion observed is that due to loss of benzoic acid. This is a structurally significant fragment but identifications are rarely based on a single product ion. Identification could be made with greater confidence if several structurally useful product ions are formed. FIG. 6b shows the spectrum acquired with the new method. This spectrum shows, in addition to benzoic acid loss, further losses of methanol and methyl acetate. Similar information would require at least three stages of mass spectrometry with the conventional method.

EXAMPLE III

FIG. 7 illustrates the use of the invention with negatively charged ions. The example shown here is that of the molecular anion of 2,4,6-trinitrotoluene (TNT), a compound of interest for the detection and identification of explosives. FIG. 7a shows the spectrum of the isolated molecular anion while 7b shows the spectrum after application of the universal collisional activation method. Note the rich fragmentation observed, unique to TNT, that allows for a highly specific identification. The conventional approach (spectrum not shown) provides many fewer product ions.

EXAMPLE IV

FIG. 8 illustrates the use of the invention for a doubly protonated peptide, neuromedin U-8 (tyr-phe-leu-arg-pro-arg-asn-NH₂), formed by electrospray ionization. This type of ion is typical of those formed, for example, from a protein tryptic digest. The spectrum shows a variety of structurally informative product ions. The most likely situation in which an ion of this type would be encountered in an analytical setting is from the chromatographic separation of a tryptic digest. In chromatography, of course, the analyte concentration varies as it elutes from the column. The number of ions formed from the analyte would therefore also be expected to vary, unless measure were taken to avoid it. The resonant frequency of the parent ion population would also change during the peak elution. This, however, poses no problem for the universal collisional activation approach although it would for the conventional approach.

While the random noise method provides an extremely wide bandwidth of excitation frequencies, in some cases it may be desirable to use a reduced range of excitation frequencies: this can be effected by using a suitable filter between the random noise generator and the ion trap. A high pass filter could be used to ensure that no ions above a specific mass-to-charge ratio are collisionally activated. This may be desirable in certain MS/MS experiments in which multiply charged ions are the species of interest. A notch filter could also be used to provide a reduced bandwidth of excitation frequencies for collisional activation. The bandwidth of this filter could be adjusted to compensate for the slight

5,206,509

7

shift in the frequencies of ions at a single mass-to-charge ratio due to changes in space charge.

The invention enables the targeted product technique described in S. A. McLuckey, et al., supra, employing collisional activation to be performed with ion trapping instruments. Conventional methods are not applicable because the targeted product ion technique requires simultaneous, non-selective collisional activation of parent ions at multiple mass-to-charge ratios. Kinetic excitation of the product ions, however, may not be desirable. This can be avoided by using an appropriate low-pass filter in conjunction with the random noise excitation. An alternative method is to use a notch rejection filter to exclude excitation frequencies corresponding to the target product ion.

In the quadrupole ion trap, the invention can include concurrent downward ramping of the ion trap radio-frequency drive voltage. This allows low mass ions formed via consecutive dissociation steps to be trapped. The drive voltage (or frequency is an) important variable in determining collision energetics in the ion trap. Frequently, the optimum drive voltage for dissociating a high mass parent ion is too high for trapping ions of lower mass. Random noise fragments formed via consecutive dissociation steps.

A typical mass spectrometry system in accordance with the invention may include support subsystems such as physical support, power supplies, control electronics, vacuum hardware, and ion source; and data acquisition subsystems such as ion detector, electrometer, analog-to-digital converter, computer and data output hardware.

While there has been shown and described what are at present considered the preferred embodiments of the invention, it will be obvious to those skilled in the art that various changes and modifications can be made therein without departing from the scope of the inventions defined by the appended claims.

What is claimed is:

1. A universal collisional activation ion trap comprising an ion trapping means having connected thereto a noise signal generator for effecting universal collisional activation of ions trapped within said ion trapping means, said ion trapping means containing a bath gas for serving as a collision partner for collisional activation and for providing a mechanism for power dissipation.
2. A universal collisional activation ion trap according to claim 1 wherein said ion trapping means comprises a quadrupole ion trap.
3. A universal collisional activation ion trap according to claim 2 wherein said quadrupole ion trap comprises a ring electrode and two end-cap electrodes.
4. A universal collisional activation ion trap according to claim 3 wherein said noise signal generator is connected to at least one of said two end-cap electrodes of said quadrupole ion trap.
5. A universal collisional activation ion trap according to claim 3 wherein said noise signal generator is

8

connected to said ring electrode of said quadrupole ion trap.

6. A universal collisional activation ion trap according to claim 1 wherein said ion trapping means comprises an ion cyclotron resonance cell.

7. A universal collisional activation ion trap according to claim 6 wherein said ion cyclotron resonance cell comprises at least two opposing electrodes, and wherein said noise signal generator is connected to at least one of said opposing electrodes.

8. A universal collisional activation ion trap according to claim 1 wherein said ion trapping means uses combined magnetic and electrodynamic forces to trap ions.

9. A method of operating a universal collisional activation ion trap comprising the steps of:

- a. providing an ion trapping means;
- b. introducing into said ion trapping means a bath gas for serving as a collision partner for collisional activation and for providing a mechanism for power dissipation; and
- c. generating a noise signal within said ion trapping means to effect universal collisional activation of ions trapped therein.

10. The method according to claim 9 further comprising the subsequent step of introducing into said ion trapping means a substance that, when acted upon by said noise signal, undergoes collisional activation to form product ions.

11. A method according to claim 9 wherein said ion trapping means comprises a quadrupole ion trap.

12. A method according to claim 11 wherein said quadrupole ion trap comprises a ring electrode and two end-cap electrodes.

13. A method according to claim 12 wherein said noise signal generator is connected to at least one of said two end-cap electrodes of said quadrupole ion trap.

14. A method according to claim 12 wherein said noise signal generator is connected to said ring electrode of a quadrupole ion trap.

15. A method according to claim 9 wherein said ion trapping means comprises an ion cyclotron resonance cell.

16. A method according to claim 15 wherein said ion cyclotron resonance cell comprises at least two opposing electrodes, and wherein said noise signal generator is connected to at least one of said opposing electrodes.

17. The method according to claim 9 further comprising the subsequent step of acquiring a mass spectrum which contains data useful for identifying said substance.

18. A mass spectrometry system comprising an ion trapping means having connected thereto a noise signal generator for effecting universal collisional activation of ions trapped within said ion trapping means, said trapping means containing a bath gas for serving as a collision partner for collisional activation and for providing a mechanism for power dissipation, support subsystems, and data acquisition subsystems.

* * * * *

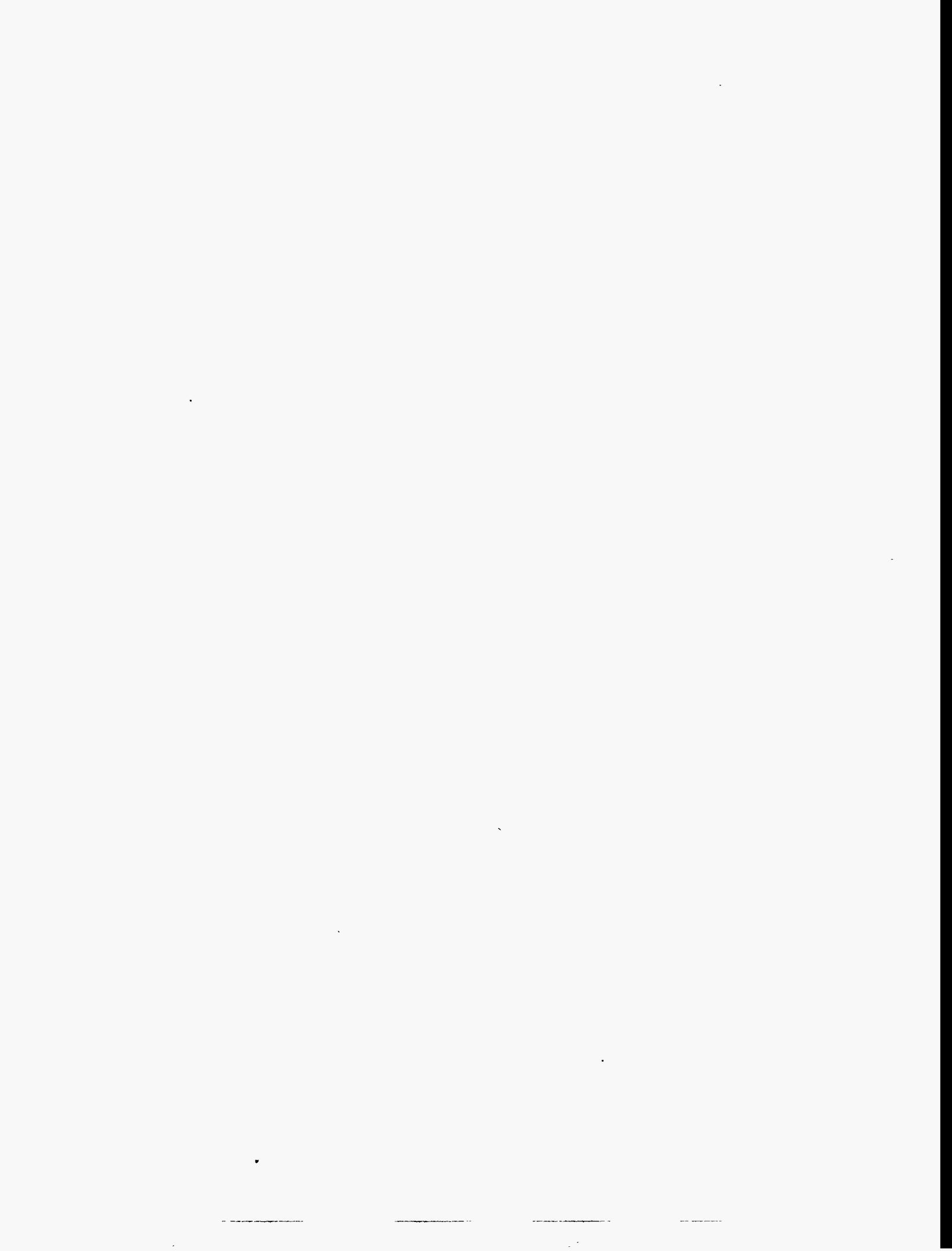

Appendix III

Other ORNL papers of direct relevance to high explosives detection

"Multiple Stages of Mass Spectrometry in a Quadrupole Ion Trap Mass Spectrometer: Prerequisites."

Scott A. McLuckey, Gary L. Glish, and Gary J. Van Berkel International Journal of Mass Spectrometry and Ion Processes, 106 (1991) 213.

"Ion Trap Mass Spectrometry."

R. Graham Cooks, Gary L. Glish, Raymond E. Kaiser, Jr., and Scott A. McLuckey, Chemical and Engineering News, 69 (1991) 26-41.

"Sequential Stages of Mass Spectrometry in a Quadrupole Ion Trap Mass Spectrometer."

John N. Louris, Jennifer S. Brodbelt-Lustig, R. GRAHAM Cooks, Gary L. Glish, Gary J. Van Berkel, and Scott A. McLuckey, International Journal of Mass Spectrometry and Ion Processes, 96 (1990) 117.

"Negative Ion Chemical Ionization in a Quadrupole Ion Trap Using Reagent Anions Injected from an External Ion Source."

Brian A. Eckenrode, Gary L. Glish, and Scott A. McLuckey, International Journal of Mass Spectrometry and Ion Processes, 99 (1990) 151.

"Structures of NO₃⁻ Formed Via Glow Discharge in Atmospheric Gases."

Richard A. Flurer, Gary L. Glish, and Scott A. McLuckey, Journal of the American Society for Mass Spectrometry, 1 (1990) 217.

"Comparison of Atmospheric Sampling Glow Discharge Ionization with Electron Ionization."

Keiji G. Asano, Scott A. McLuckey, and Gary L. Glish Spectroscopy International Journal, 8 (1990) 191.

"The Coupling of an Atmospheric Sampling Ion Source with an Ion Trap Mass Spectrometer."

Scott A. McLuckey, Gary L. Glish, and Keiji G. Asano Analytica Chimica Acta, 225 (1989) 25.

"Atmospheric Sampling Glow Discharge Ionization Source for the Analysis of Trace Organics in Ambient Air."

Scott A. McLuckey, Gary L. Glish, Keiji G. Asano and Barry C. Grant Analytical Chemistry, **60** (1988) 2220.

"Dished Peaks from Collision-Induced Dissociations."

Scott A. McLuckey and Gary L. Glish, International Journal of Mass Spectrometry and Ion Processes, **76**, (1987) 41.

"The Effect of Charge on Hydroxyl Loss from Ortho Substituted Nitrobenzene Ions."

Scott A. McLuckey and Gary L. Glish, Organic Mass Spectrometry, **22** (1987) 224.

"Collision Activated Decomposition of Negative Ions in an Ion Trap Mass Spectrometer."

Scott A. McLuckey, Gary L. Glish and Paul E. Kelley, Analytical Chemistry, **59**, (1987) 1670.

"The Effect of Para Substituents on the "Ortho" Effect in Anions of Substituted Nitroaromatics."

Gary L. Glish and Scott A. McLuckey, Advances in Mass Spectrometry, **10B** (1986) 777.

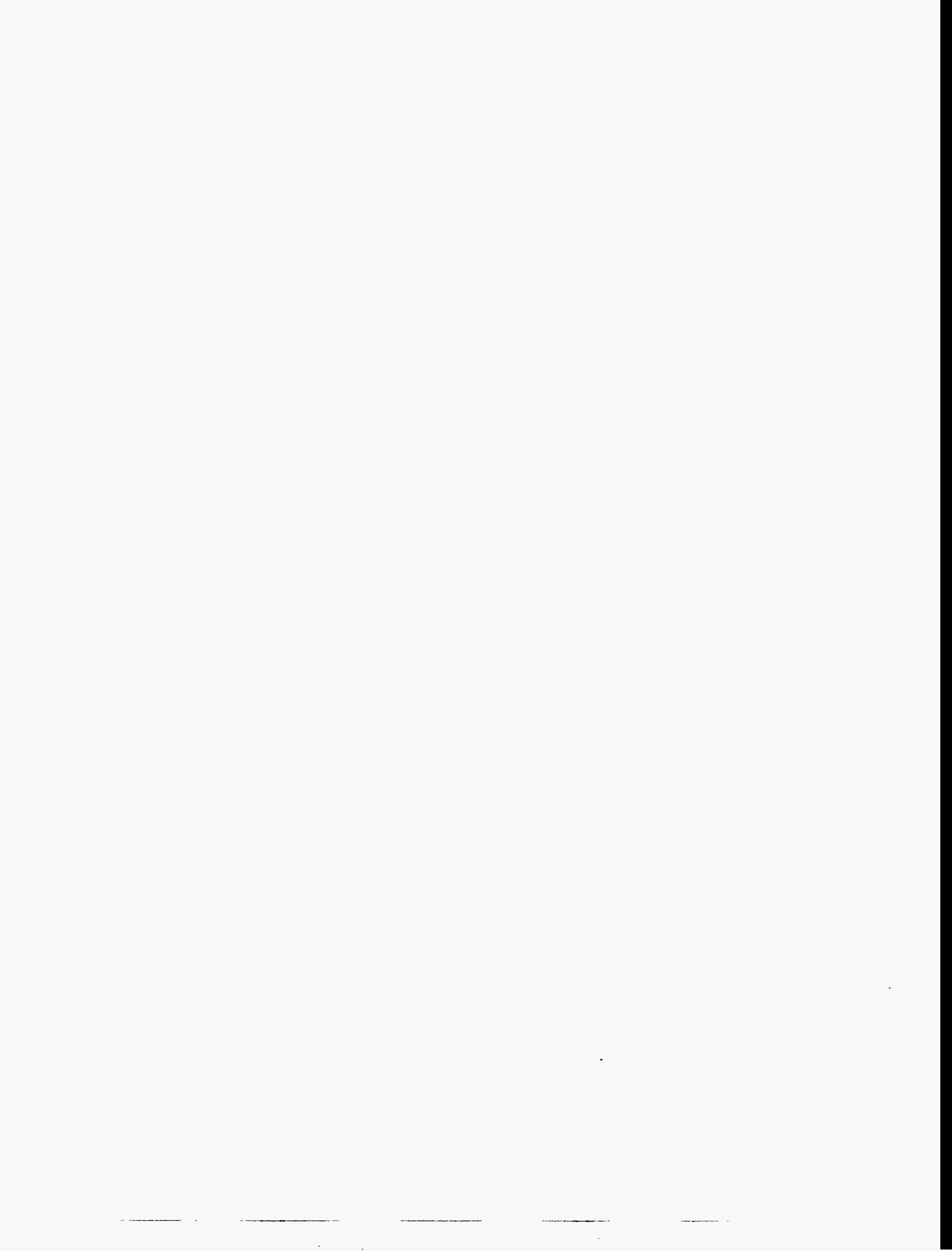

Appendix IV

Machine drawings for glow discharge ion trap housed in 6" cube

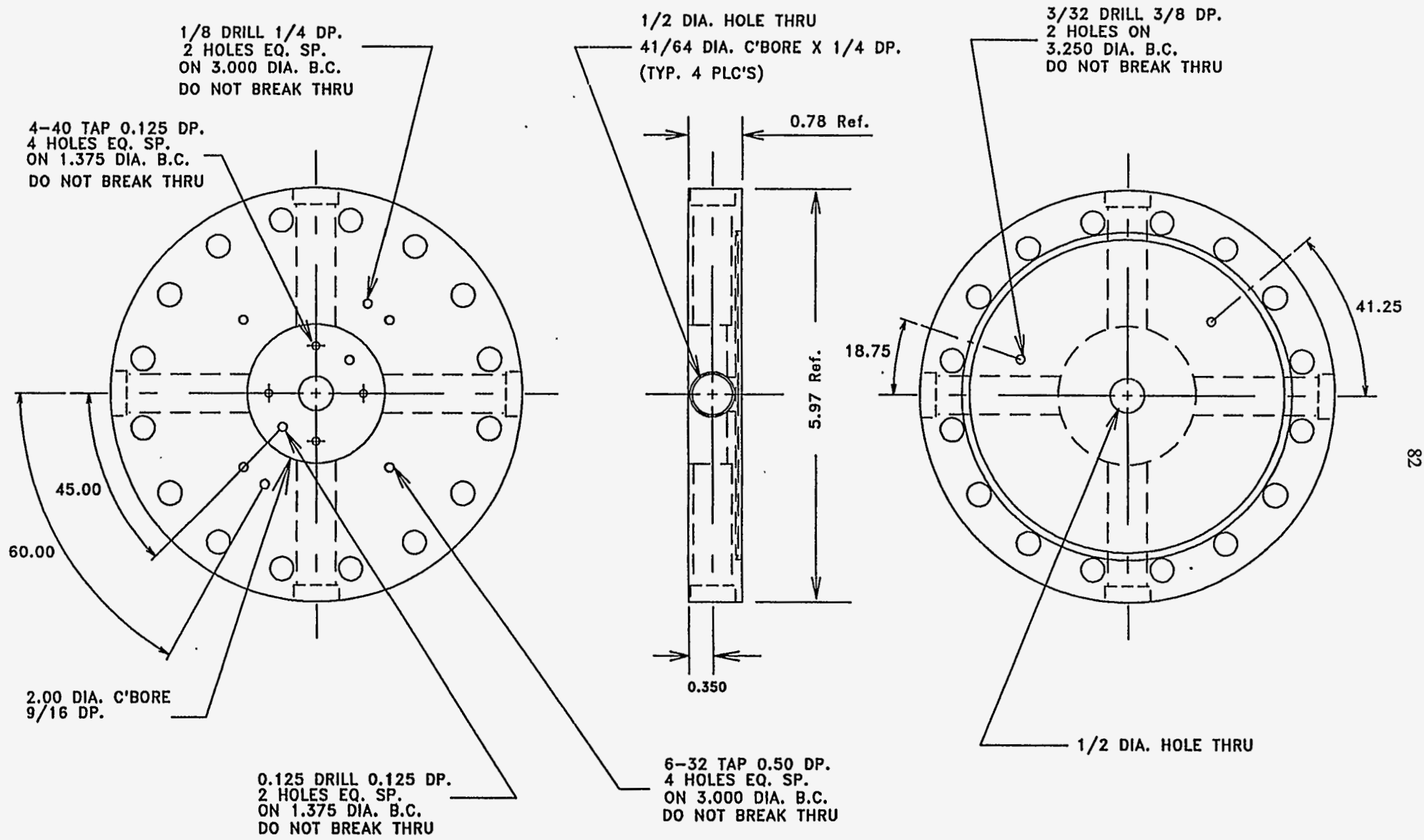

ASGDI Source Flange
Modified 6-inch Conflat

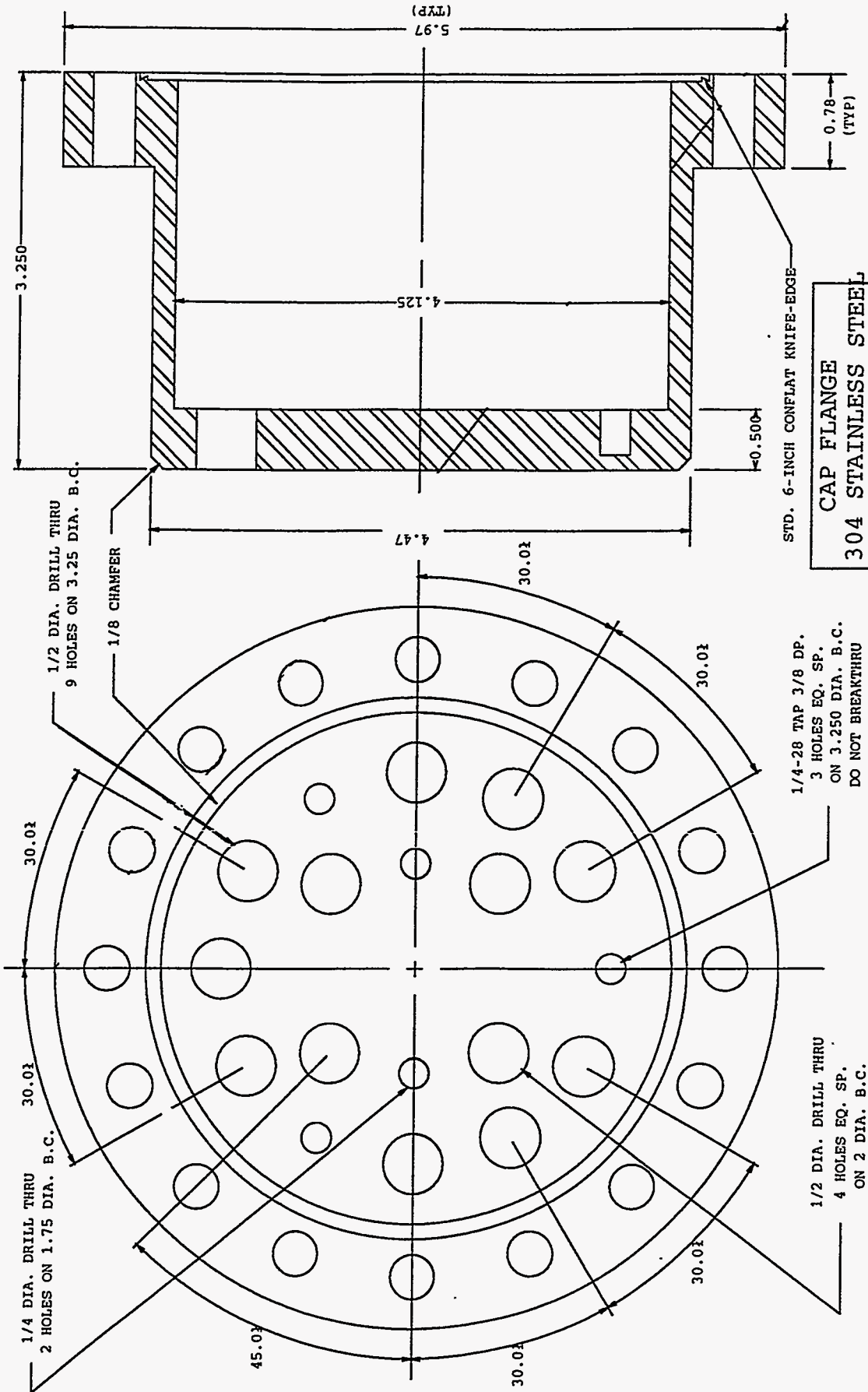

1/4 DIA. DRILL THRU
2 HOLES ON 1.75 DIA. B.C.

1/2 DIA. DRILL THRU
9 HOLES ON 3.25 DIA. B.C.

1/8 CHAMFER

1/2 DIA. DRILL THRU
4 HOLES EQ. SP.
ON 2 DIA. B.C.

1/4-28 TAP 3/8 DP.
3 HOLES EQ. SP.
ON 3.25 DIA. B.C.
DO NOT BREAKTHRU

CAP FLANGE
304 STAINLESS STEEL

STD. 6-INCH CONFLAT KNIFE-EDGE

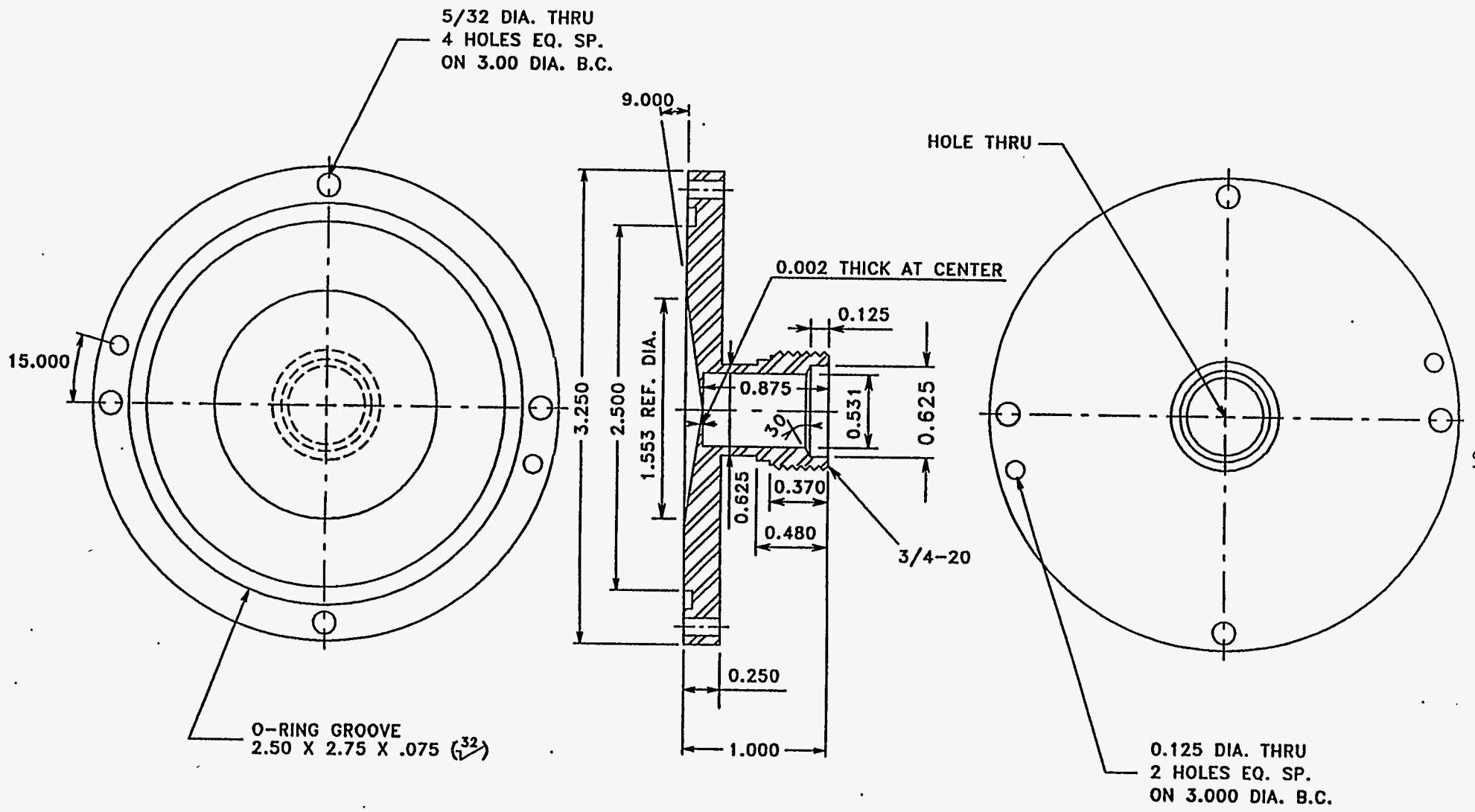

84

ASGDI Front Aperture
304 Stainless Steel

1/8 DRILL THRU
4 HOLES EQ. SP.
ON 1.375 DIA. B.C.

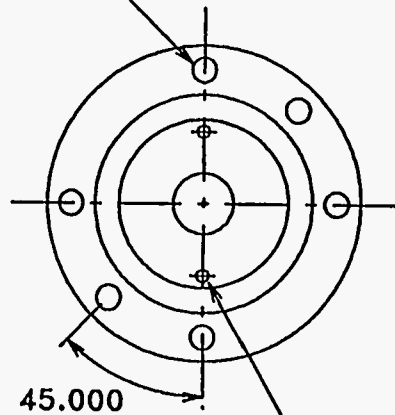

2-56 TAP .125 DP.
2 HOLES EQ. SP.
ON .750 DIA. B.C.
DO NOT BREAK THRU

O-RING GROOVE BOTH SIDES
.875 X 1.125 X .05 ($\sqrt{32}$)

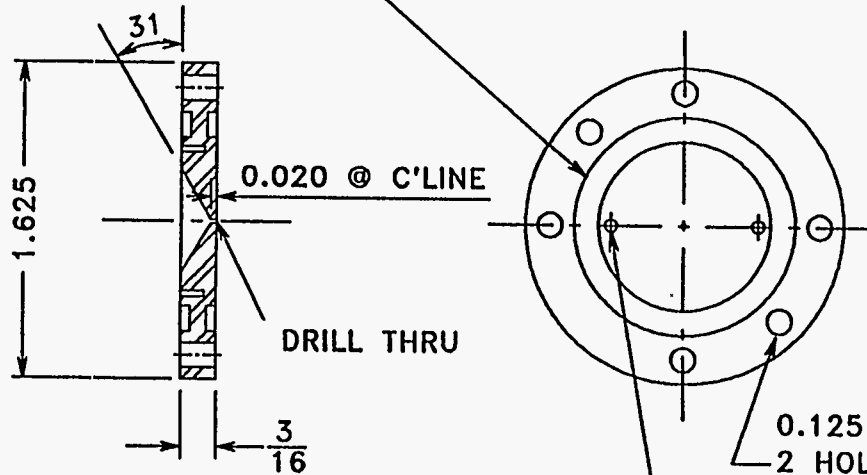

2-56 TAP .125 DP.
2 HOLES EQ. SP.
ON .750 DIA. B.C.
DO NOT BREAK THRU

0.125 DRILL THRU
2 HOLES EQ. SP.
ON 1.375 DIA. B.C.

ASGDI Back Aperture
304 Stainless Steel

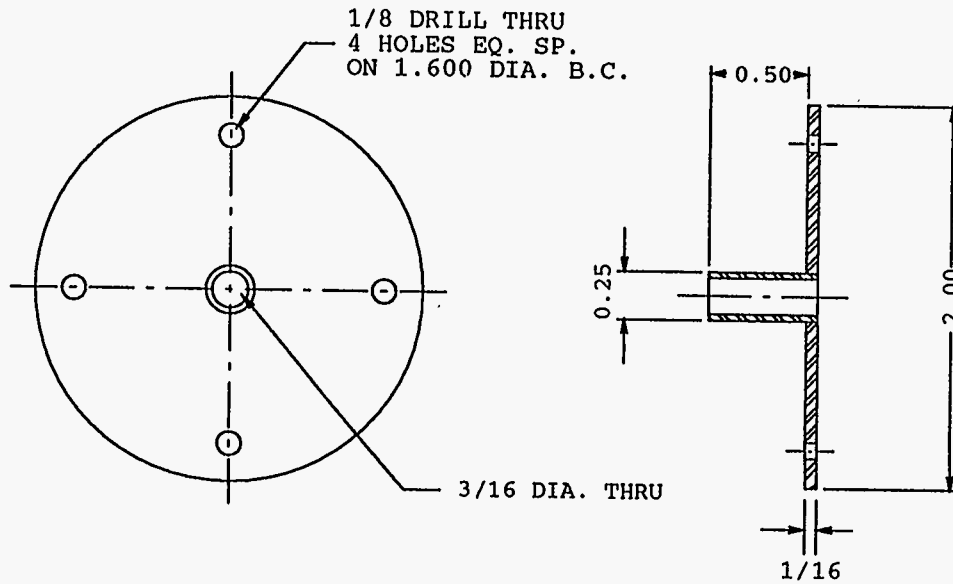

Injection Lens
304 Stainless Steel

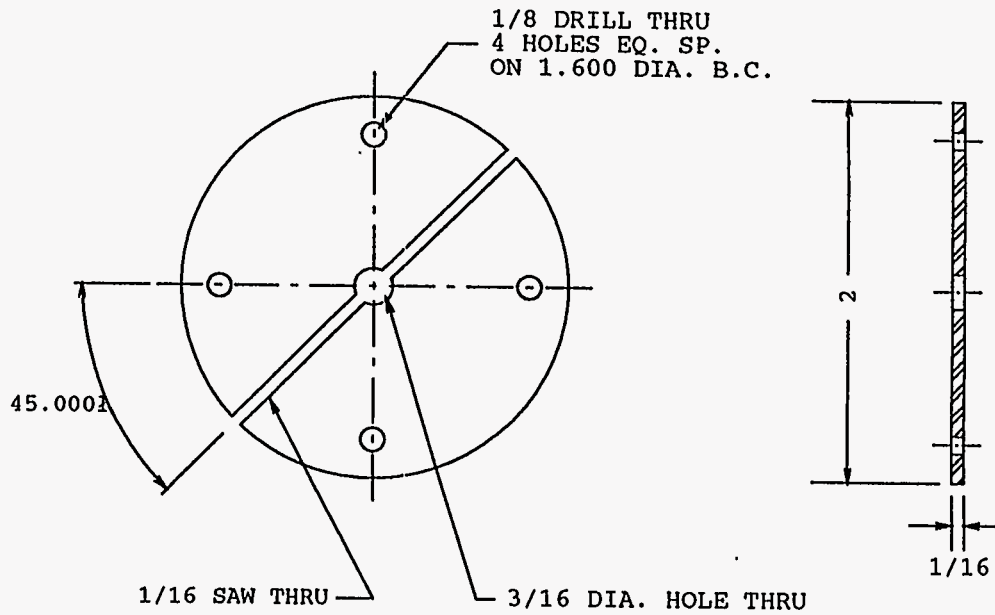

Half Plates
304 Stainless St

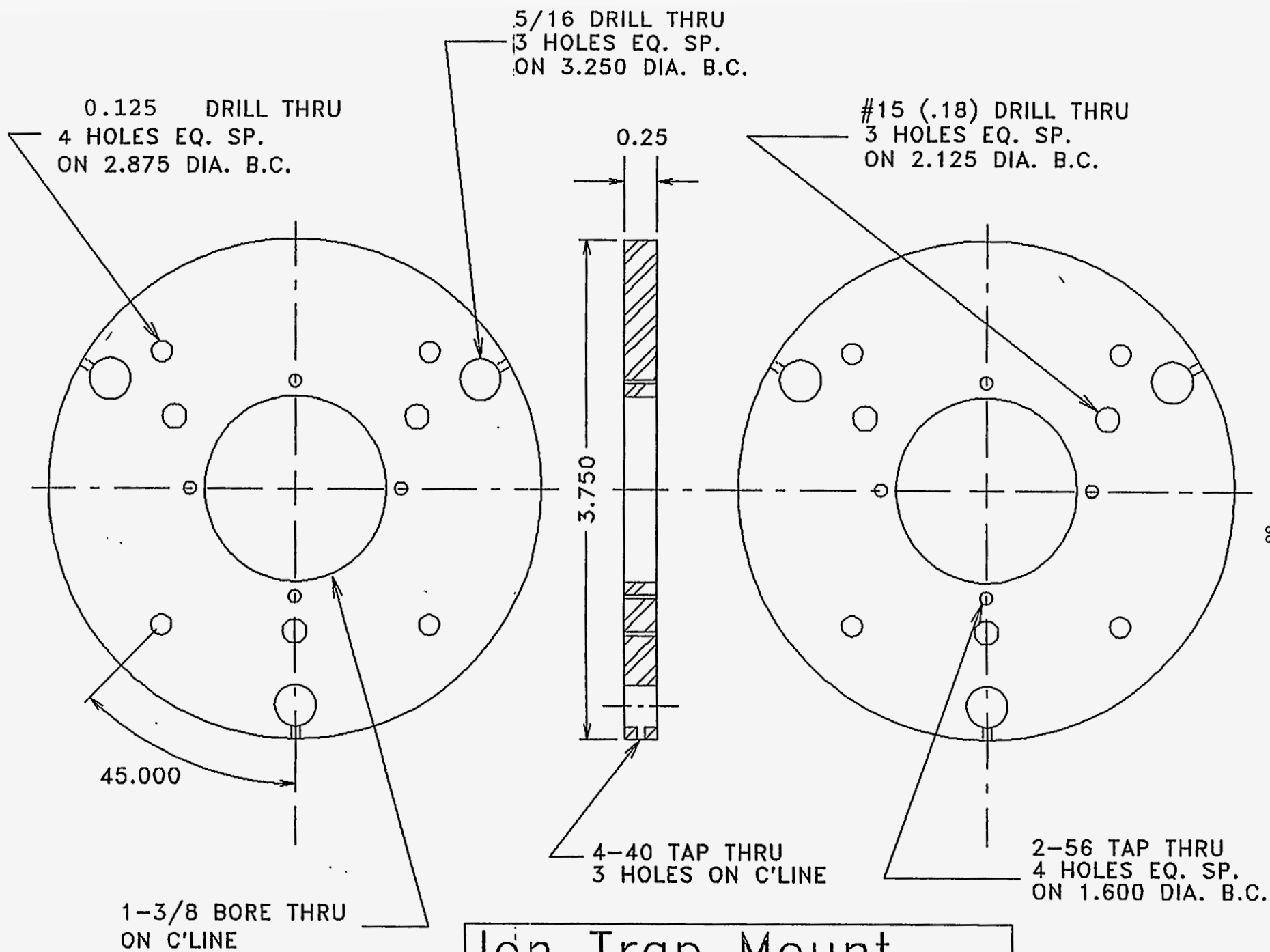

Ion Trap Mount
 304 Stainless Steel

3/8 DRILL THRU
9 HOLES ON
3-1/4 DIA. B.C.

5/16 DRILL THRU
3 HOLES EQ. SP.
ON 3.250 DIA. B.C.

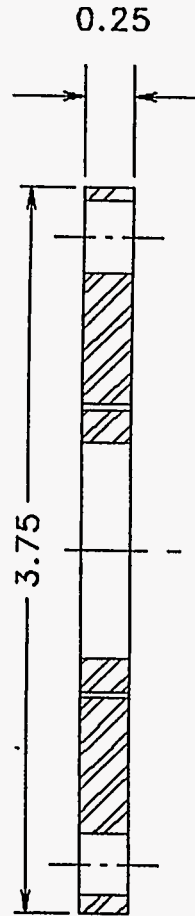
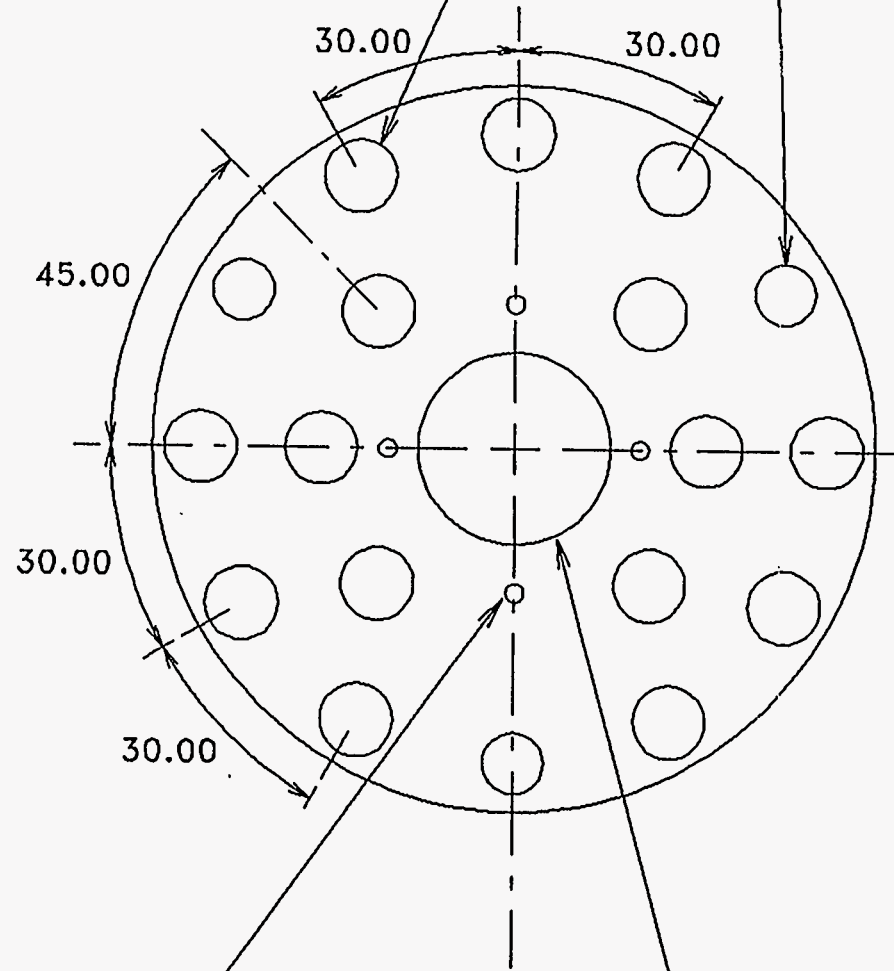

#32 (.116) DRILL THRU
2 HOLES EQ. SP.
ON 1-5/16 DIA. B.C.

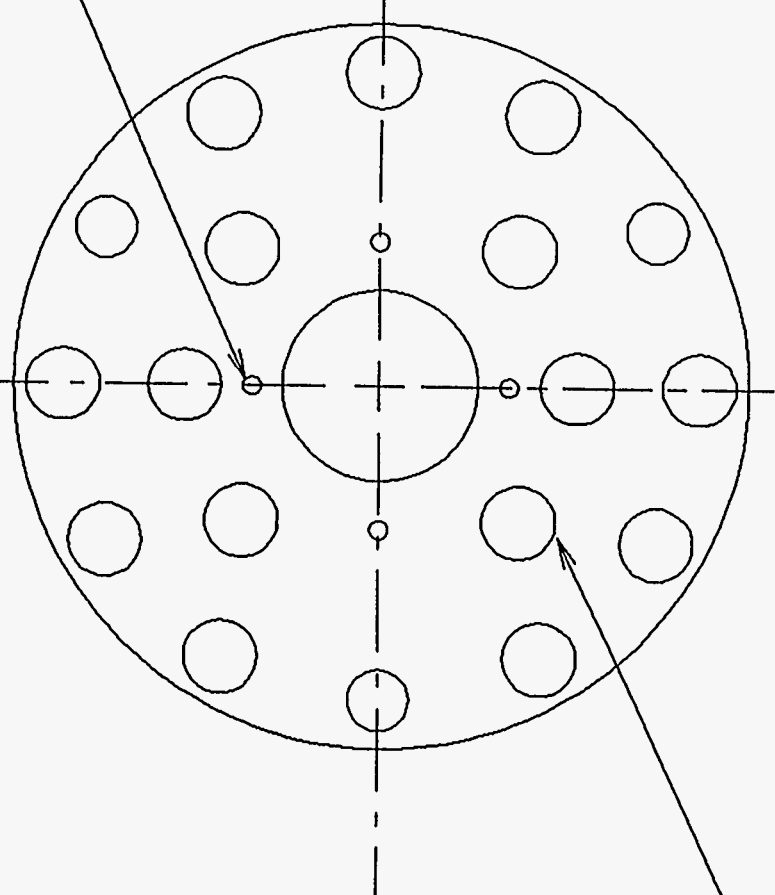

4-40 TAP THRU
2 HOLES EQ. SP.
ON 1-1/2 DIA. B.C.

3/8 DRILL THRU
6 HOLES
ON 2 DIA. B.C.

Detector Mount
304 Stainless Steel

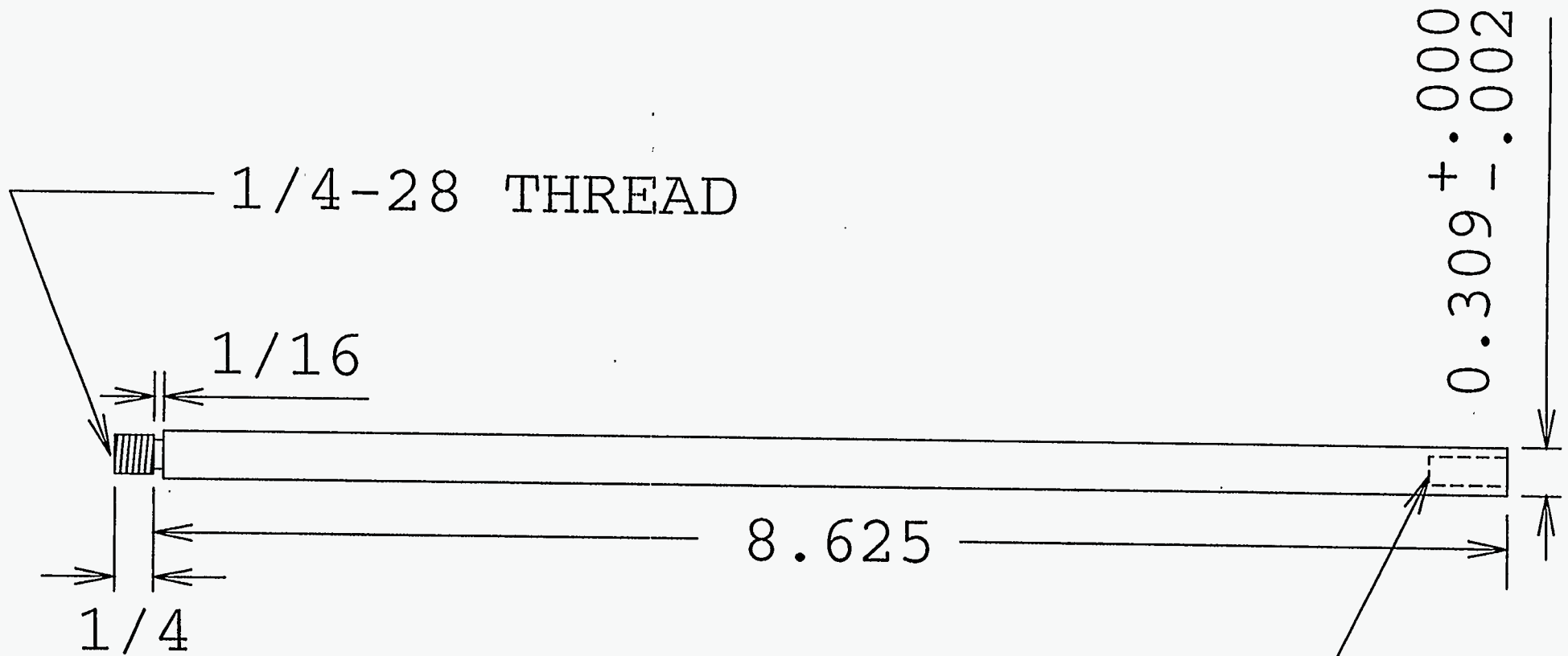

.1875 DIA. DRILL
1/2 DP. ON C'LINE

Ion Trap Mounting Rod
304 Stainless Steel

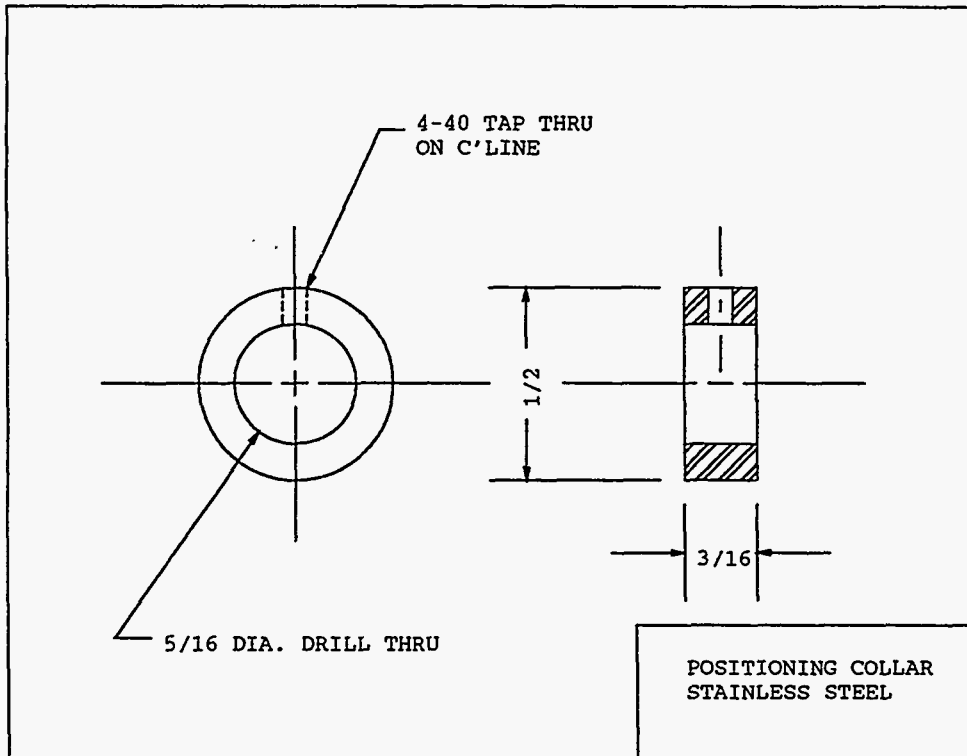

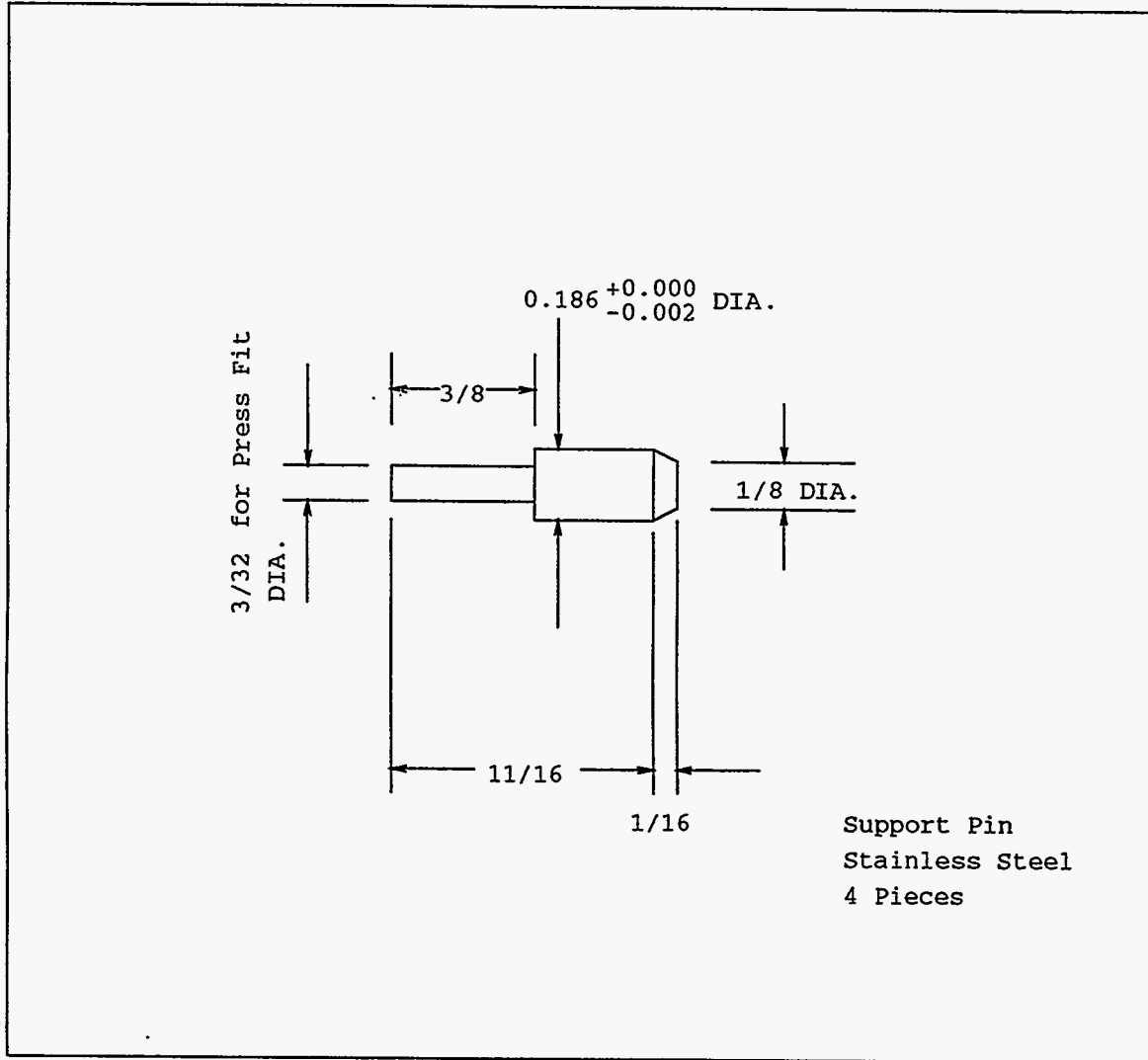

Appendix V

**Machine drawings for adapting a Teledyne 3DQ ion trap for
atmospheric sampling glow discharge**

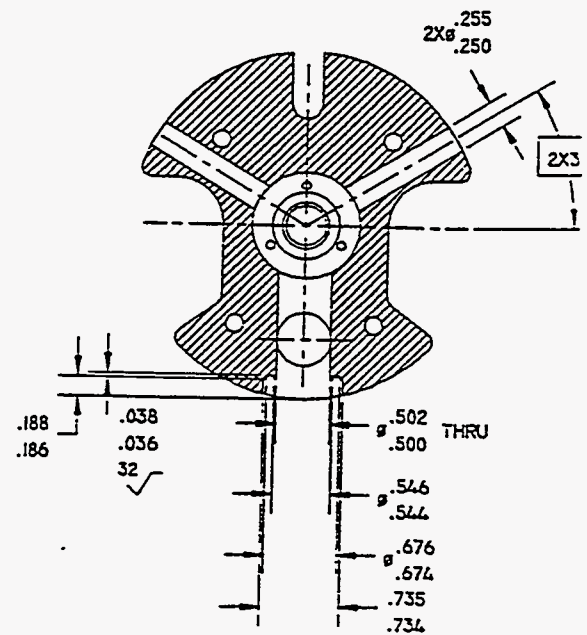
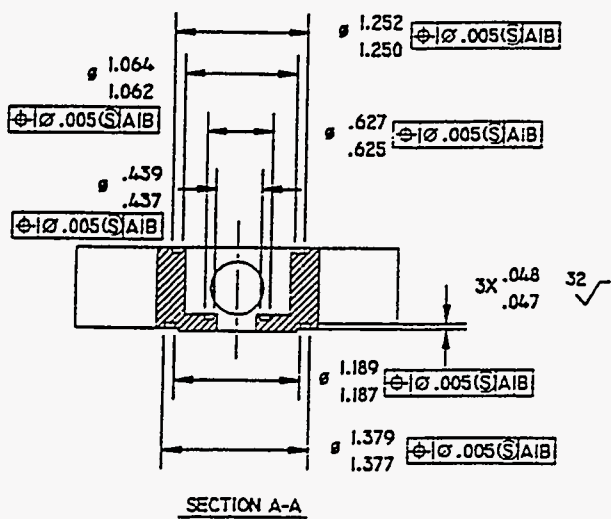
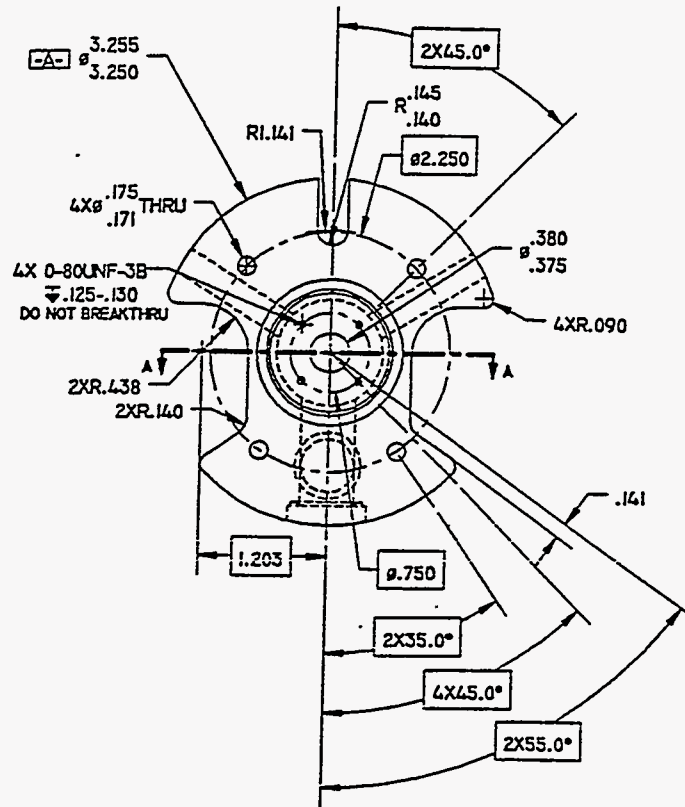

SECTION B-B

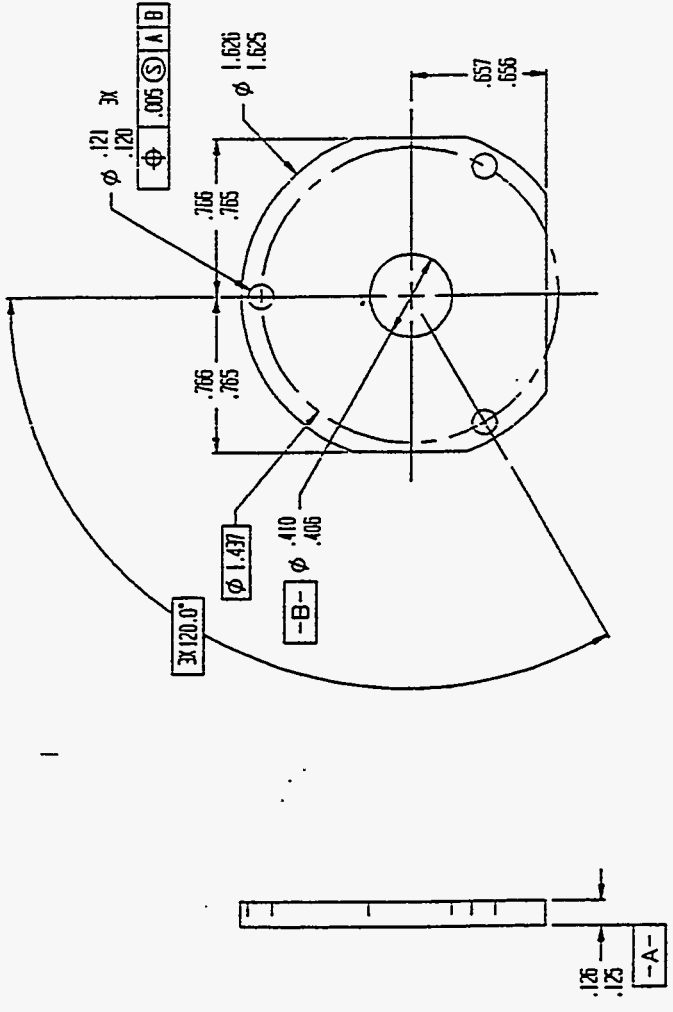

3DQ ASGDI SOURCE
FRONT PLATE

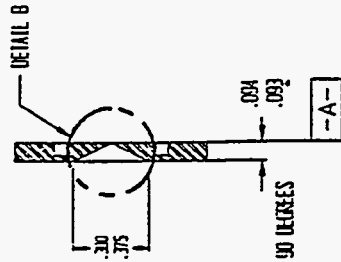
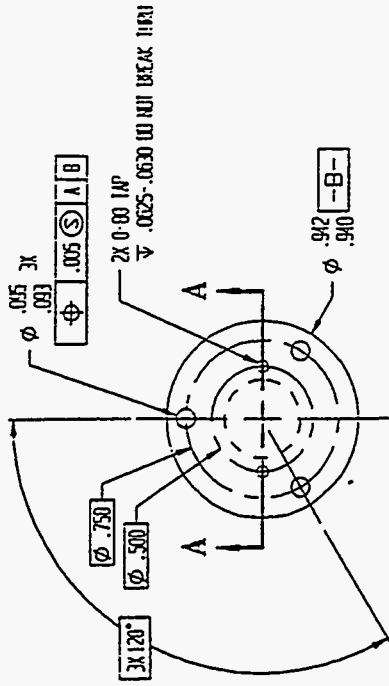

DETAIL A

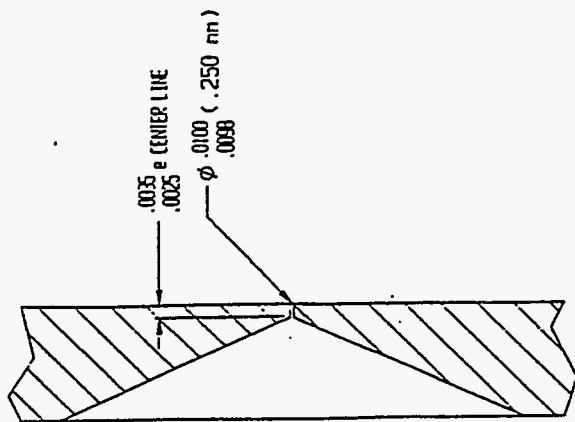

DETAIL B

3DQ ASGDI SOURCE REAR APERTURE PLATE

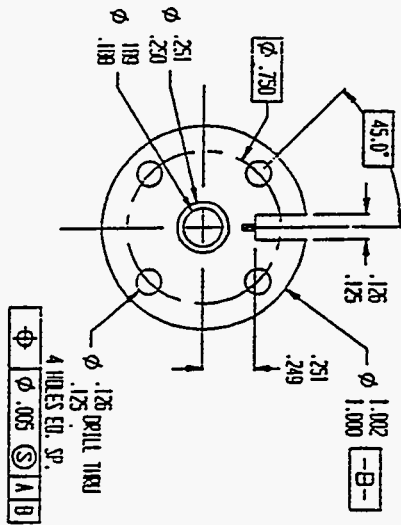
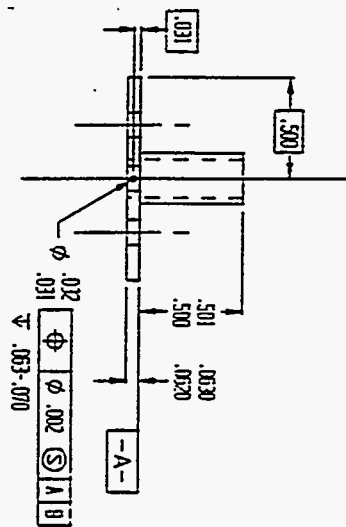

3DQ ASGDI SOURCE
INJECTION LENS

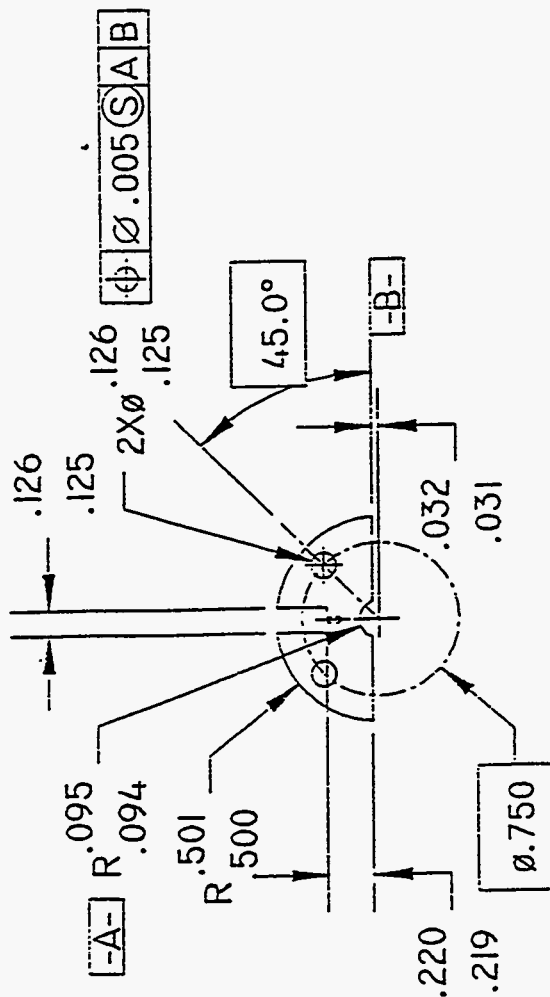
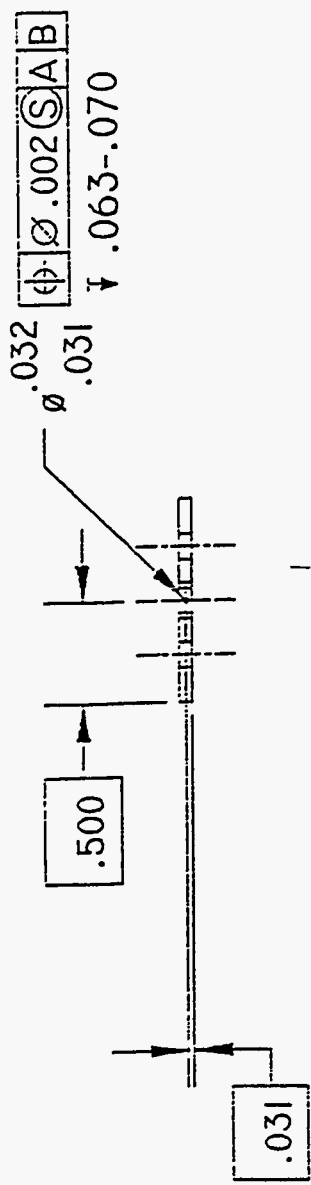

3DQ ASGDI HALF PLATE

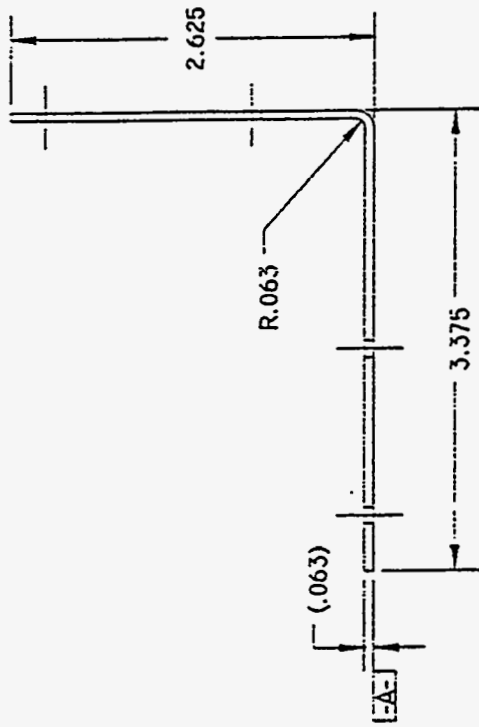
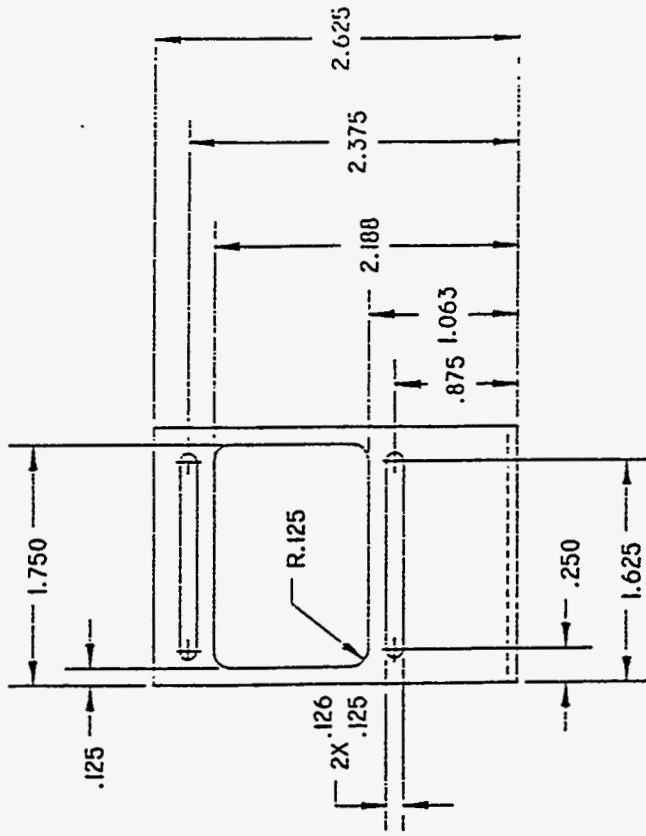
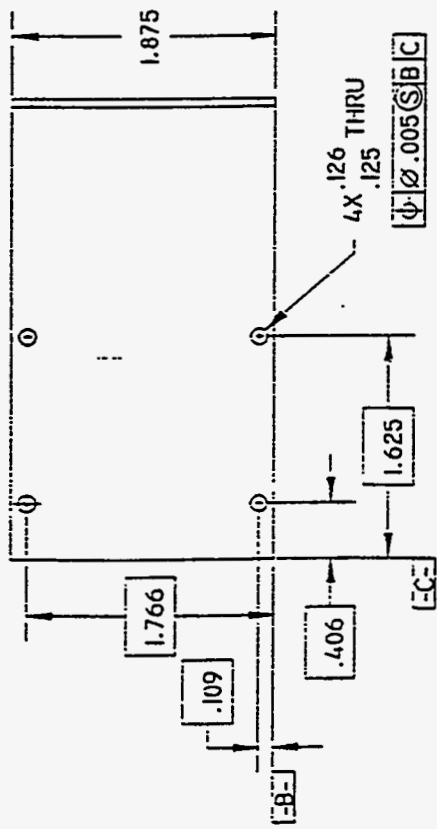

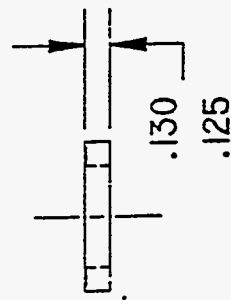
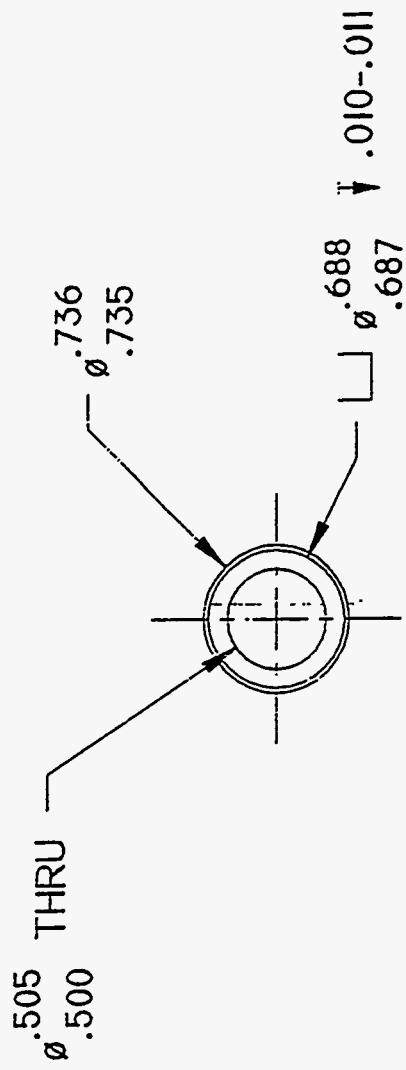

VIEWING LENS RETAINER

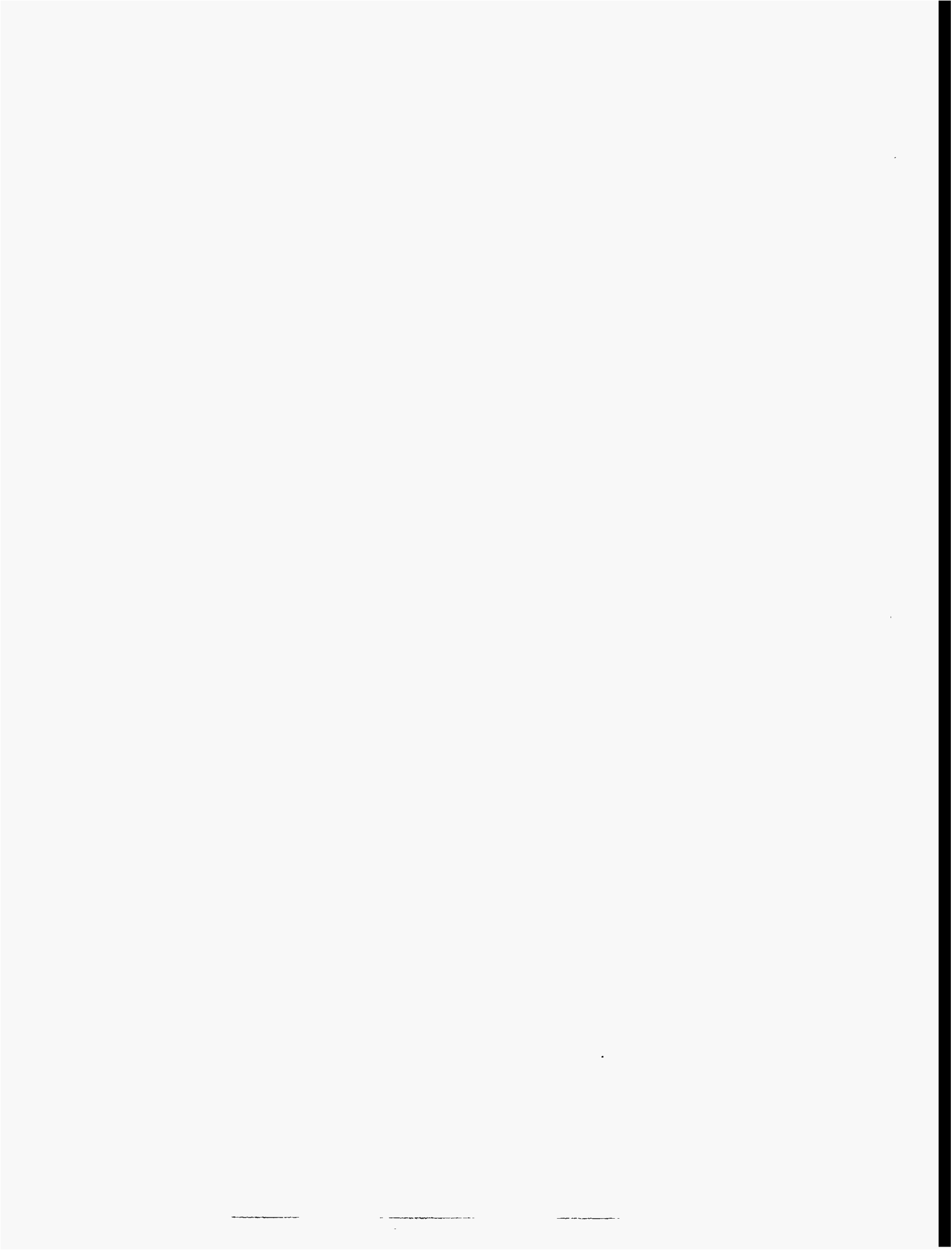

INTERNAL DISTRIBUTION

1. B. R. Appleton
- 2-11. K. G. Asano
12. M. V. Buchanan
- 13-22. D. E. Goeringer
23. R. L. Hettich
24. G. B. Hurst
- 25-34. S. A. McLuckey
35. M. L. Poutsma
36. R. S. Ramsey
37. J. L. Stephenson, Jr.
38. G. J. Van Berkel
39. Central Research Library
40. Document Reference Section
- 41-42. Laboratory Records - RC
43. Laboratory Records
44. ORNL Patent Section

EXTERNAL DISTRIBUTION

45. K. E. Sanders, Director, International Safeguards Division, NN-44, Department of Energy, Washington, D.C. 20585.
46. J. Puckett, International Safeguards Division, NN-44, Department of Energy, Washington, D.C. 20585.
47. Office of Scientific and Technical Information, P.O. Box 62, Oak Ridge, Tennessee 37831.
48. Office of Assistant Manager of Energy Research and Development, Oak Ridge Operations, P.O. Box 2008, Oak Ridge, Tennessee 37831-6269.

