

**FORCED CHEMICAL VAPOR INFILTRATION OF TUBULAR GEOMETRIES:
MODELING, DESIGN, AND SCALE-UP**

D.P. STINTON,* T.M. BESMANN,* W.M. MATLIN,** T.L. STARR,*** AND
W.A. CURTIN†

*Oak Ridge National Laboratory, Oak Ridge, TN 37831-6063

**University of Tennessee, Knoxville, TN 37996-2200

***Georgia Institute of Technology, Atlanta, GA 30332

†Virginia Polytechnic Institute and State University, Blacksburg, VA 24061-0219

RECEIVED

DEC 08 1995

OSTI

ABSTRACT

The development of thick-walled, tubular ceramic composites has involved investigations of different fiber architectures and fixturing to obtain optimal densification and mechanical properties. The current efforts entail modeling of the densification process in order to increase densification uniformity and decrease processing time. In addition, the process is being scaled to produce components with a 10 cm outer diameter.

INTRODUCTION

In advanced indirectly fired coal combustion systems and externally fired combined cycle concepts, ceramic heat exchangers are required to transfer heat from the hot combustion gases to the clean air that drives the gas turbines. For high efficiencies, the temperature of the turbine inlet needs to exceed 1100°C and preferably be about 1260°C. The heat exchangers will operate under pressure and experience thermal and mechanical stresses during heating and cooling, and some transients will be severe under upset conditions. Silicon carbide-matrix composites appear promising for such applications because of their high strength at elevated temperature, light weight, thermal and mechanical shock resistance, damage tolerance, and oxidation and corrosion resistance.

Fiber-reinforced ceramic composites are generally anisotropic because of the directional dependence of the continuous fibers. Therefore, mechanical properties of typical flexure specimens or C-ring specimens are not representative of the properties of tubular composites because the continuous fibers are severed. If structural members for coal-fired power plants are to be successfully designed with composite materials, the directional properties must be measured so that structural analysis programs may be used to establish the correct stress states and, subsequently, the correct sizes and shapes of the structural components. Although quite complex, all the elastic material constants can be determined from a single tubular specimen by applying a variety of combinations of tension, compression, and shear stresses and taking multiple readings of strains.

Fiber-reinforced composite tubes of several fiber architectures were fabricated by forced chemical vapor infiltration (FCVI) and characterized. Unfortunately, long times (~ 150 hours) were required to thoroughly densify the tubes. An objective of the current investigation was to optimize the forced CVI process so that composite tubes could be fabricated in much shorter times. To aid in such optimization, a computer code which models the CVI process was used to identify critical process parameters.

MASTER

"The submitted manuscript has been authored by a contractor of the U.S. Government under contract No. DE-AC05-84OR21400. Accordingly, the U.S. Government retains a nonexclusive, royalty-free license to publish or reproduce the published form of this contribution, or allow others to do so, for U.S. Government purposes."

Finally, successful demonstration of the utility of composite tubes for these applications will require the testing of near-full scale components. As a result a new infiltration system was designed and constructed to prepare 10-cm diameter tubes, and is described in this report.

TUBULAR SPECIMEN FABRICATION

Preforms

Nicalon ceramic grade fibers (Nippon Carbon Co., Tokyo, Japan) were utilized for the fabrication of the preforms. Nicalon is a SiC-based polymer-derived fiber that is microcrystalline/amorphous in nature and contains significant amounts of silica.^{1,2} Three types of preforms were fabricated: Cloth-wrapped, angle-wound, and braided. The cloth wrapped preforms were prepared by tightly wrapping strips of Nicalon cloth (20 cm wide by 220 cm long) onto 2.54 cm diameter graphite mandrels to form tubes with fiber contents of ~32 vol%. The cloth was an 16x16 plain weave with 500 fibers per tow. Higher fiber loading was certainly desired, however, it was not possible to wrap the cloth any tighter by hand.

The angle-wound preforms were prepared by winding onto a graphite mandrel with the 500 fiber tows wound 10° off the hoop direction to provide some axial strength. Adjacent fiber tows were placed in contact with each other to prevent formation of large pores. The winding procedure yielded a preform with a fiber loading of ~40%.

Quadrax Corp. for this effort prepared 3-dimensional braided preforms on graphite mandrels, also using 500 fiber tows. The braid was specially designed to have a high fiber loading, ~38%, since typical braided materials have only 15-30% volume fraction of fibers.

Densification

Forced chemical vapor infiltration (CVI) as developed at the Oak Ridge National Laboratory has been used to fabricate composites of thick-walled tubular geometry. Details of the forced-CVI process have been reported in numerous publications.³⁻⁶ Briefly, fibrous preforms are constrained by special fixturing such that reactants are forced through the walls of the preform (Fig. 1). Gaseous reactants enter the furnace through tubing that runs within the water cooling passage of the stainless steel injector. Reactants flow from the tubing in the cooling passage into a graphite gas distributor and are dispersed along the length of the preform through parallel slots in the distributor. Reactants then proceed uniformly through holes in the graphite mandrel into the preform. A temperature gradient is established through the preform wall such that decomposition of the methyltrichlorosilane (CH_3SiCl_3 , or MTS) and deposition of SiC occurs in the presence of hydrogen as the gases approach the higher temperature regions of the preform. As the density and thermal conductivity of the preform increases, deposition moves progressively toward the inner diameter of the tube. The duration of infiltration is therefore controlled by the temperature gradient throughout the preform and the reactant flow.

Densification of tubular preforms (2.5 cm inner dia. by 0.6 cm wall thickness by ~20 cm long) required infiltration times of ~150 hours. Infiltration times were excessively long because of the steep temperature gradient through the preform (from ~1200°C on the outside of the preform to about 500°C on the inside of the preform). Temperatures were determined using a special preform instrumented with a thermocouple on the inner diameter of the preform.

A modification was then made to the processing equipment by removing the graphite gas distributor, leaving only an air gap between the graphite mandrel and the stainless steel injector.

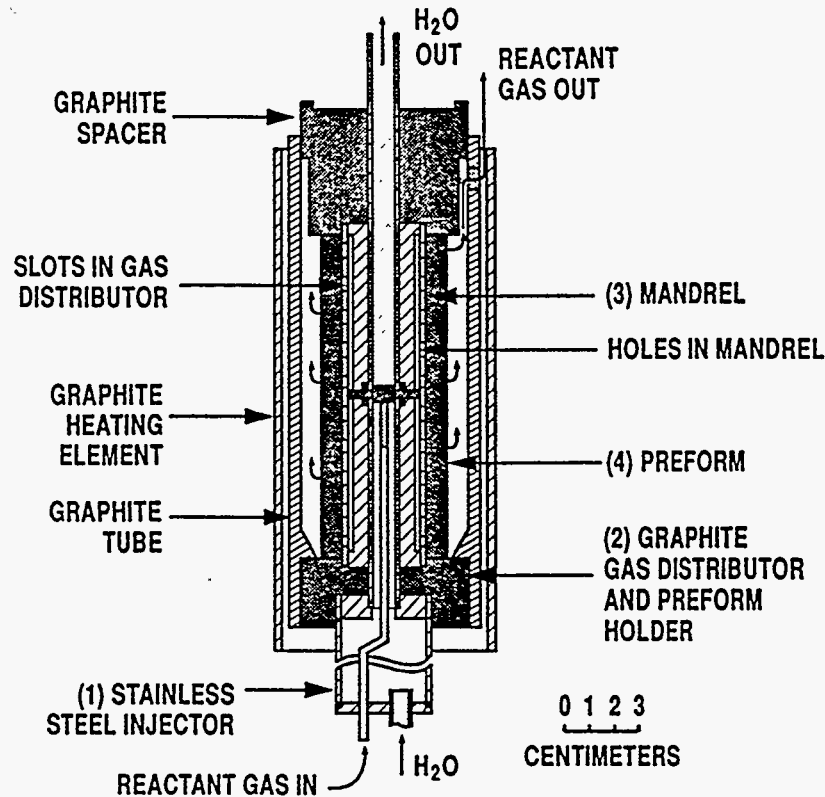

Fig. 1. Schematic of the small-scale FCVI unit for fabricating tubular composites.

Infiltration of tubes using this equipment was accelerated considerably. The temperature along the inner diameter of the fibrous preform was increased to 730°C and infiltration times were reduced to approximately 40 h. The external surfaces of the tubes were sealed with a chemical vapor deposited overcoat of SiC.

PROCESS MODELING

The small-scale FCVI system has been modeled using the computer code GTCVI, which utilizes a three-dimensional finite volume representation of the system and considers mass and heat transfer and chemical kinetics.⁷ Figure 2 contains flow vectors, isotherms, and a density profile for the system at 40 h. The centerline is represented by the y axis, followed radially by the flow tube, the annular space, the mandrel, and the preform. It is apparent that flow is restricted in the lower volume of the tube due to the presence of only a single inlet to the annulus. Heat loss at the ends also results in a temperature depression. The effect on the uniformity of infiltration is seen in the density profile (Fig. 2c) which reveals, asymmetric lower density regions at the ends, with the lower end having a somewhat lower density.

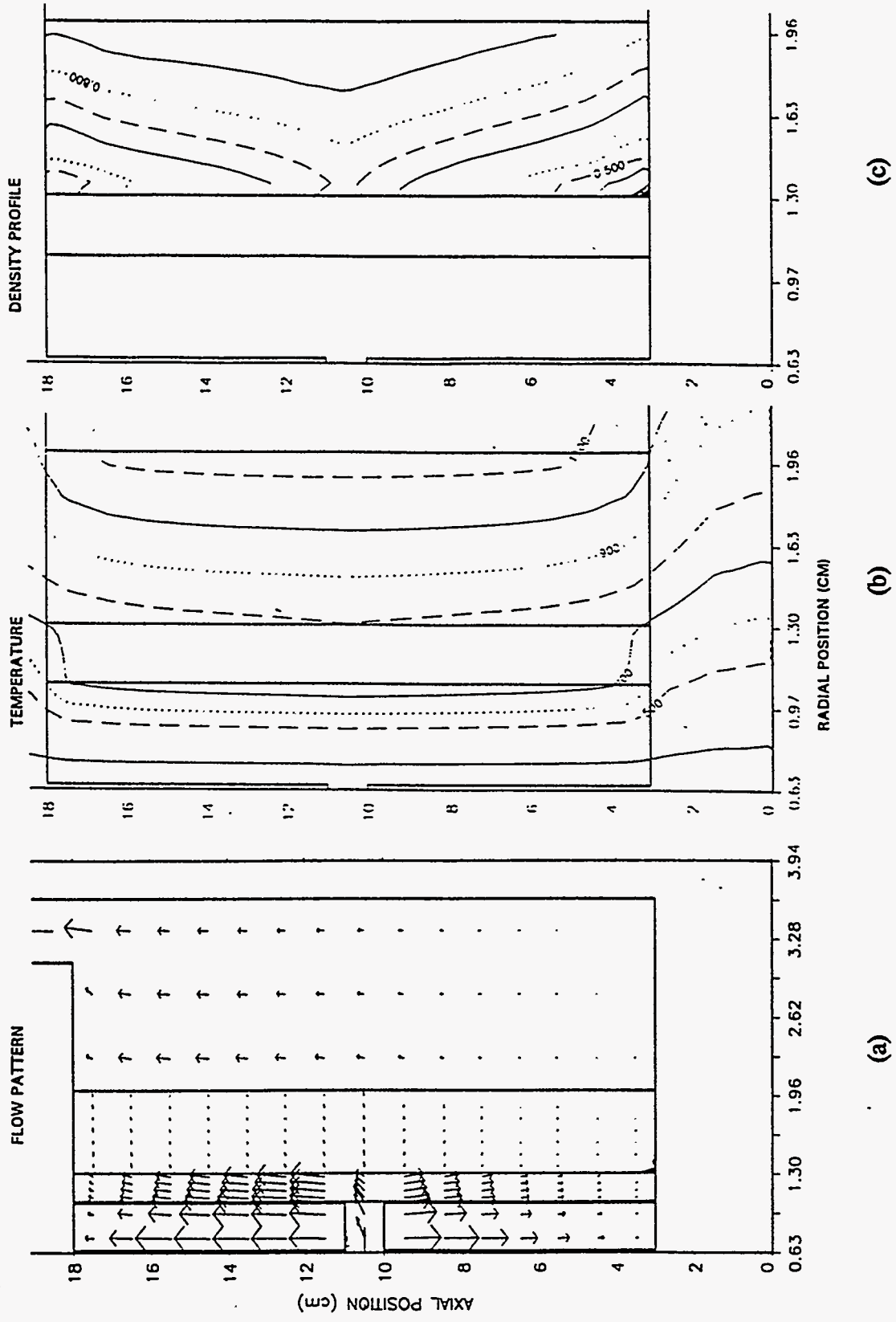

Fig. 2. GTCVI computational model results at 40 h for run conditions: Furnace temperature 1275 °C, hydrogen flow 630 cm³/min, MTS:H₂. Indicated are the a) flow vectors, b) isotherms (°C), and c) relative density profile.

CHARACTERIZATION

Non-destructive Evaluation

Computerized tomographic X-ray images were obtained of radial sections of the infiltrated tubes using a Scientific Measurement Systems Model 101B+ industrial system. The unit makes translate-rotate scans of specimens using a 420 kV X-ray tube source with a linear array of 125 collimated detectors. Figure 3 shows images for the three densified tubes exhibiting several problems. Images of the cloth-wrapped tube reveal significant delamination

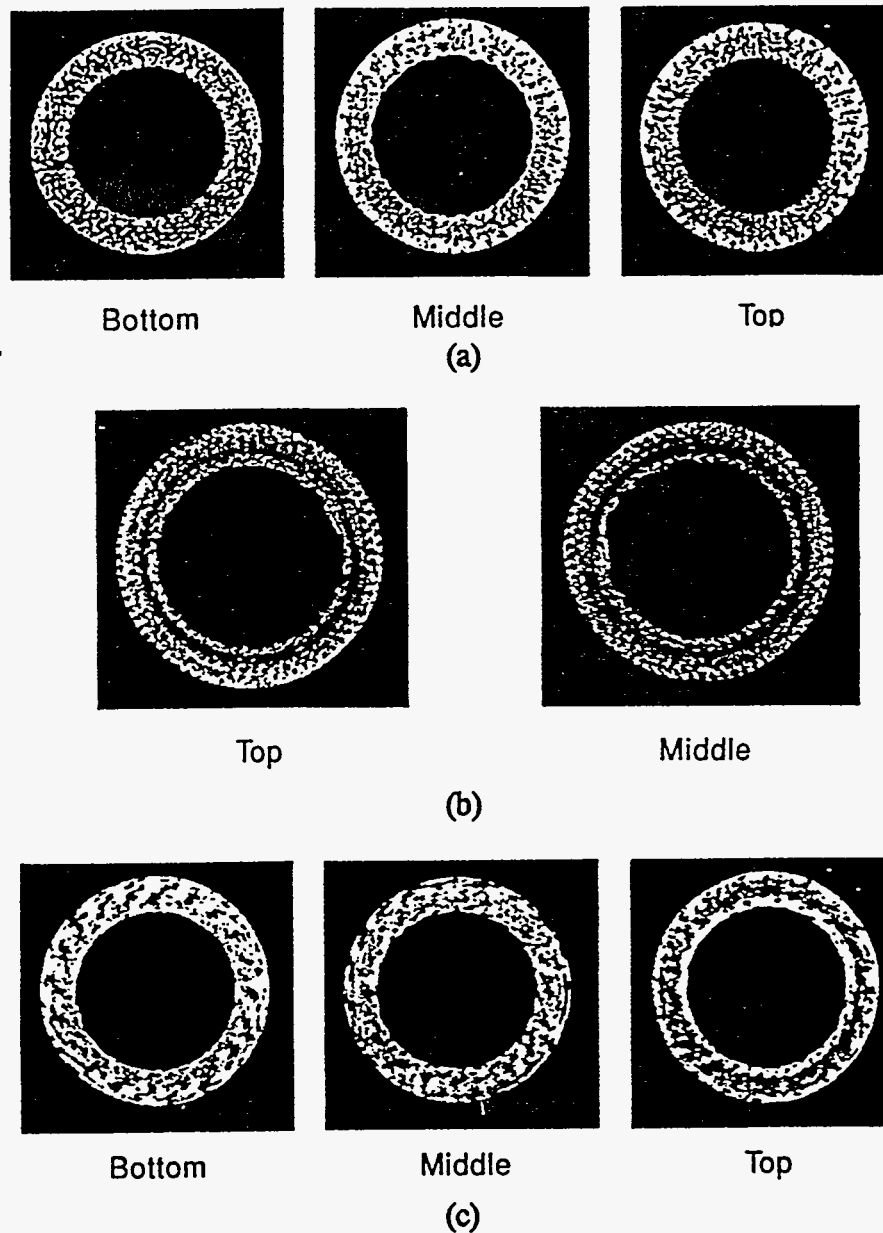

Fig. 3. Computed X-ray tomographic images of tubes densified from a) angle-wound, b) cloth-wrapped, and c) braided preforms. The tubes have a 4-cm outer diameter.

and large porosity between cloth layers (Fig. 3a). Angle-wound preforms resulted in a composite with circumferentially and radially oriented porosity (Fig. 3b). And the braided tubes had large pore located near the outer diameter (Fig. 3c). All these flaws are due to the nature of the preform or its fabrication.

Stiffness Measurements

The densified tubes were mechanically tested using an Instron computer-controlled, high stiffness biaxial test facility developed at the Virginia Polytechnic Institute for this application. The unit has special grips designed for tubes and an oven for elevated temperature experiments. Shear modulus measurements were performed at room temperature and were 94.4 GPa for the cloth-wrapped tube and 126 GPa for the braided tube. Axial stiffness measurements were performed in air at room temperature, 400°C, 600°C, and 800°C. The values appeared to be unaffected by temperature and were ~258 GPa, ~152 GPa, and ~266 GPa for the cloth-wrapped, angle-wound, and braided tubes, respectively.

A cloth-wrapped tube was fitted with strain gages at 2.5 cm intervals along the length of the tube for 13 cm both front and back to specifically measure variations in local strain, and hence local stiffness. The results are shown in Fig. 4, which demonstrates nonuniformity in density due to variability in infiltration along the axis.

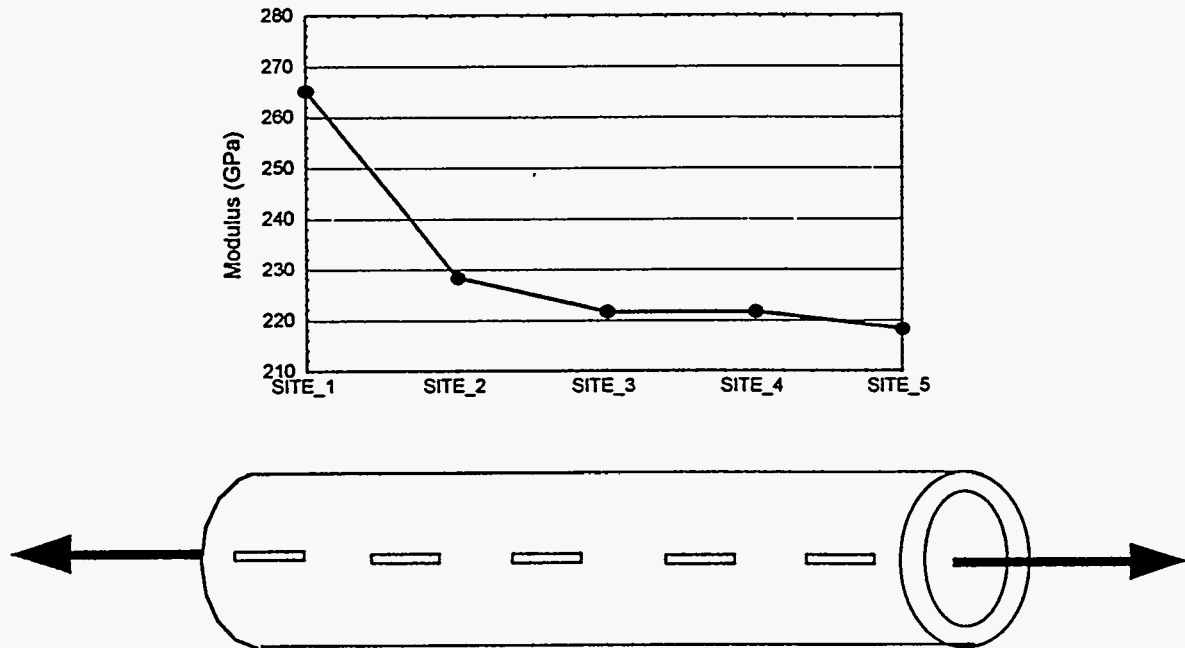

Fig. 4. Variation of axial stiffness along a cloth-wrapped tube.

SCALE-UP

A scale-up FCVI system for tubular shapes was designed and constructed by American Furnace Co., Knoxville, TN, to prepare 10-cm outer diameter tubes. Utilizing the experience developed with the smaller system described above, significant improvements were incorporated into the scale-up design (Fig. 5). Instead of single gas path into the preform from the injector, there are multiple entry points. There is greater flexibility in controlling the inner diameter (cooled-side) temperature through the use of forced air or water as the coolant. The system also allows sealing of the ends of the preform via flanges at the ends of the mandrel. With the smaller system such seals were made by pressure-fitting furnace components against the end of the preform, which often deformed and did not make a good seal, resulting in leakage of precursor gases out of the end of the preform. The scale-up system is completing installation and should be operational in the Spring of 1995.

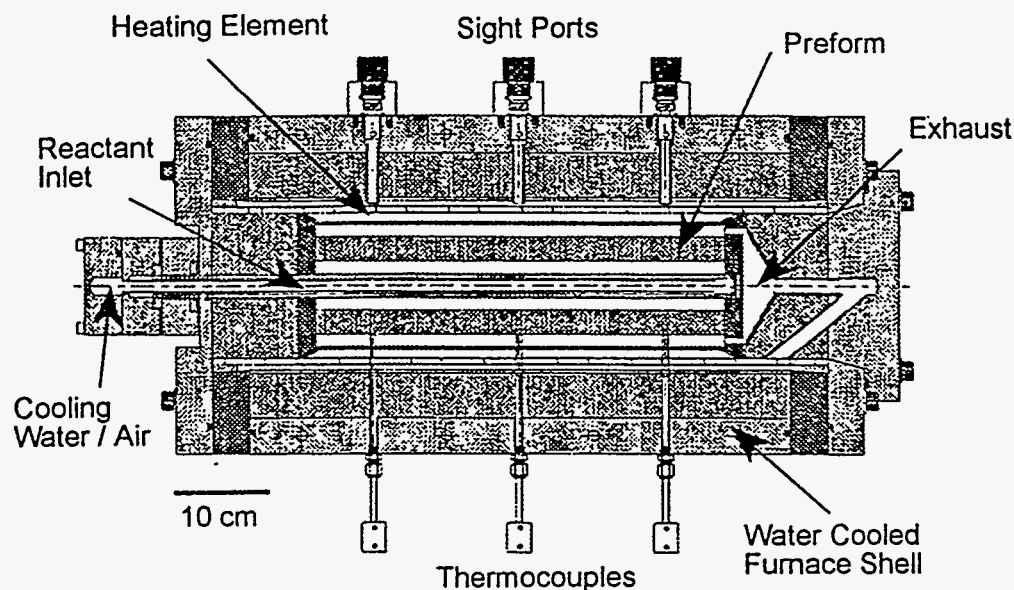

Fig. 5. Schematic of the scale-up FCVI system for preparing 10-cm diameter tubular composites.

CONCLUSIONS

Tubular composites of Nicalon/SiC can be fabricated using FCVI, however, the first generation apparatus allows insufficient control to prepare uniformly dense components. A computational model of the FCVI system was used to identify key issues in densification. The results indicated that adjustment of the temperature gradient would be beneficial, which when implemented allowed reduction of infiltration times from ~ 150 h to ~ 40 h. Non-destructive evaluation revealed issues related to organized porosity in preforms, which may result in flaws effecting ultimate strength.

Stiffness measurements indicated that the materials maintain their properties to at least 800°C , although the effect of axial nonuniformity of densification can be detected. Finally, a scale-up system to produce 10-cm diameter tubular shapes has been constructed which is designed to overcome the limitations of smaller-scale system.

ACKNOWLEDGEMENTS

The authors are indebted to R.B. Dinwiddie and R.A. Lowden for their thoughtful comments. B.E. Foster of ORNL performed the non-destructive evaluation work. Research sponsored by the U. S. Department of Energy, Office of Fossil Energy, Advanced Research and Technology Development Materials Program, under contract DE-AC05-84OR21400 with Lockheed Martin Energy Systems.

REFERENCES

1. S. Yajima, et al., J. Am. Ceram. Soc., 59[7-8], 324 (1976).
2. S. Yajima, et al., Nature, 27[21], 706 (1979).
3. D. P. Stinton, R. A. Lowden, and T. M. Besmann, in Proceedings of the Sixth Annual Conference on Fossil Energy Materials, Oak Ridge National Laboratory Report ORNL/FMP-92/1, (1992) pp 3-10.
4. D. P. Stinton, A. J. Caputo, and R. A. Lowden, Am. Ceram. Soc. Bull., 65[2], 347 (1986).
5. D. P. Stinton, T. M. Besmann, and R. A. Lowden, Am. Ceram. Soc. Bull. 67[2], 350 (1988).
6. T. M. Besmann, B. W. Sheldon, R. A. Lowden, and D. P. Stinton, Science, 253, 1104 (1991).
7. T. Starr, A. Smith, T. Besmann, J. McLaughlin, and B. Sheldon, in High Temperature Matrix Composites, edited by R. Naslain, J. Lamon, and D. Doumeingts (Woodhead Pub. Ltd., Cambridge, 1993), pp. 231-240.

DISCLAIMER

This report was prepared as an account of work sponsored by an agency of the United States Government. Neither the United States Government nor any agency thereof, nor any of their employees, makes any warranty, express or implied, or assumes any legal liability or responsibility for the accuracy, completeness, or usefulness of any information, apparatus, product, or process disclosed, or represents that its use would not infringe privately owned rights. Reference herein to any specific commercial product, process, or service by trade name, trademark, manufacturer, or otherwise does not necessarily constitute or imply its endorsement, recommendation, or favoring by the United States Government or any agency thereof. The views and opinions of authors expressed herein do not necessarily state or reflect those of the United States Government or any agency thereof.