

CASE FILE

RM L54B12a

COPY



NACA

RESEARCH MEMORANDUM

FLIGHT TESTS OF A MAN STANDING ON A PLATFORM

SUPPORTED BY A TEETERING ROTOR

By Paul R. Hill and T. L. Kennedy

Langley Aeronautical Laboratory
Langley Field, Va.

**NATIONAL ADVISORY COMMITTEE
FOR AERONAUTICS**

WASHINGTON

March 24, 1954

Declassified April 11, 1955

NACA RM L54B12a

NATIONAL ADVISORY COMMITTEE FOR AERONAUTICS

RESEARCH MEMORANDUM

FLIGHT TESTS OF A MAN STANDING ON A PLATFORM

SUPPORTED BY A TEETERING ROTOR

By Paul R. Hill and T. L. Kennedy

SUMMARY

Because previous flight tests of a man standing on a jet-supported platform were very successful, a series of flight tests were made to determine the flying qualities of a man standing on a platform supported by a teetering rotor. The rotor was 7 feet in diameter and was driven by air jets at the rotor tips fed by hollow blades and air hoses connected to an external air supply. The machine was tested with a free-teetering rotor and with a spring-restrained rotor, and, as an alternate arrangement, with the rotor and foot platform isolated from the framework by rubber connections to reduce the inertia of the moving parts. The machine was tested indoors in hovering and in limited translational flight and outdoors in light and in strong gusty winds.

The stability and controllability with the spring-restrained rotor were uniformly good. The stability with the free-teetering rotor was marginal, but, when an experienced flyer placed his hands on a hand rail, the stability and controllability were good. The stability and controllability with the rubber-isolated frame and spring-restrained teetering rotor were very good and quite like the jet-supported platform.

INTRODUCTION

Reference 1 describes a series of experiments carried out to investigate the feasibility of the free flight of an individual standing and balancing on a thrust vector. In those experiments the thrust vector was the reaction of a supersonic air jet which was directed downward from a nozzle fastened on the bottom of a small board on which the flyer stood. Air was transported to this device by hoses connected to an external air supply. The principal finding was that a person can stand on and control a jet-supported platform in free flight. This vehicle could easily be controlled in both hovering and translational flight.

The large amount of power required to support the weight of a man and machine by the direct action of a jet-propulsion device makes this method one which is costly. The generation of the required lift by a rotor or propellers offers a more economical method. This was fully realized by the authors of reference 1 who devised the test equipment of that investigation as the simplest possible means of investigating the balance principle involved. It seemed reasonable that the balance principle could then be applied to practical vehicles using any suitable means of generating the necessary lifting forces.

Utilization of the balance principle on practical rotor-driven machines introduced a number of additional questions to be answered. Would gyroscopic precession due to large angular momentum of rotating parts be excessive? Would the greater mass improve or harm the flying qualities? What would be the effect on the rotor of forward speed or gustiness? Would torque balance be a significant problem? Would ground reaction be a significant aid in stabilizing altitude control during landing and take-off?

The balance principle involved is explained in detail in reference 1. If the machine is in trim and has no externally applied moments, the flyer controls the resultant thrust vector with his feet so that it passes through the combined center of gravity. If the machine is out of trim, the flyer puts moments on the machine with his feet to cause the thrust vector to create righting moments about the center of gravity as required. The balance principle depends in part on the property of the lift-generating machine to tilt in about the same direction as that in which a control moment is applied. However, single-rotation rotors or other rotating machinery with a vertical axis of rotation respond to an impressed moment by precessing in a direction at right angles to the impressed moment. In reference 1 it was shown that a gyroscopic momentum of a value corresponding to the rotating part of a suitable reciprocating engine drive was not of sufficient magnitude to have a noticeable effect on balance. However, the much larger angular momentum of a supporting rotor might be of sufficient magnitude to create difficulty.

Two simple propeller or rotor systems that may be used to neutralize the gyroscopic moment are: (1) counterrotating propellers, where the angular momentum is simply canceled, and (2) the teetering rotor where the rotor rapidly follows the foot-control plane by means of aerodynamic forces.

A large pressurized air supply was available to use as a power source. The use of such a supply in conjunction with a drive by air jets in the rotor tips to give balanced torque made the use of a teetering rotor attractively simple. In addition, the teetering rotor seemed well suited for research purposes, since by restraining or locking the rotor at the teetering hinge, the effect of gyroscopic precessional moments on the flying qualities could be determined.

A machine with a two-bladed teetering rotor was built and tested in hovering flight and in limited translational motion at the Langley Pilotless Aircraft Research Station at Wallops Island, Va. The machine was exceptionally simple in that no blade-control linkages of any kind, such as for cyclic or collective pitch, were utilized.

TEST VEHICLE

The test vehicle is shown in figure 1. The lifting element of the vehicle was a rotor of 7-foot diameter and 7-inch chord. The tubular steel frame incorporated a centrally located steel platform 21 inches in diameter covered by a 14- by 28-inch piece of plywood on which the flyer stood. The machine had four legs which provided a floor clearance of 10 inches to the center line of the rotor. It had some overhead tubular framework including a ring surrounding the flyer to be used as a hand rail and to provide some protection in case of a hard landing or other accident. As a further precaution, the rotor was completely covered by a wire screen to prevent accidental contact of the flyer with the rotor.

A drawing of the rotor is shown in figure 2. The blades were built up with a Strux (a foamy plastic) core which was wrapped with layers of Fiberglas impregnated with Paraplex P43 plastic. The blades had no planform taper or twist. They are basically of an NACA 65(216)415 airfoil section. However, the blades are wrapped with more layers of Fiberglas inboard of the 32-inch station, causing the blade to taper in thickness from 23.5 percent chord at the 9-inch station to 15 percent chord at the 32-inch station. A 0.688-inch inside-diameter tube of Fiberglas impregnated with plastic was located at the 25-percent-chord station to carry air to the rotor tip. At the tip a 90° elbow in the tube directed the air to the rear to provide the driving torque. No attempt was made to mass-balance the blades about the quarter chord.

The hollow steel hub to which the blades were attached is shown in figure 3. It was in the form of a hollow yoke which surrounded and was pinned to a hollow rotating shaft by hollow pins to permit the passage of the propulsion air. These pins formed the pivot for the teetering action of the blade. The propulsion air entered downward through a fixed central spindle which was perforated to permit the passage of air into the hollow rotating rotor shaft from whence the air passed through the pins, into the yoke and through the blades. A soft leather seal was used to seal against the leakage of air between the fixed and rotating shafts. The rotating shaft was ball-bearing mounted.

Two adjustable stop bolts used to limit the degree of rotor teetering can be seen in figure 3. Their purpose was to prevent the rotor from striking or rubbing the frame. By extending these bolts to one limiting

position the teetering action was completely prevented and the rotor and hub became as a single rigid piece. By adding a small collar and suitable lugs to the rotor, a pair of springs were connected between the teetering blade and the rotating shaft to create a spring restraint. The springs used can be seen in figure 4. A calibration of the teetering restraint with this spring in position gave a spring constant of 2.72 pound-feet per degree deflection.

The test vehicle, which was designed with little attempt to make it light, weighed 140 pounds. Its center of gravity was located $5\frac{1}{2}$ inches above the steel disk of the platform. The moment of inertia of the complete vehicle about a horizontal axis through the center of gravity was 20 slug-foot². The moment of inertia of the rotor about the teetering axis is 0.55 slug-foot².

In order to find the effect of reducing the inertia of the machine, an alternate configuration arrangement was obtained by attaching the rotor mounting flange rigidly to the foot-control board by long through bolts which passed freely through oversize holes in the central steel disk of the frame. Attachment of the rotor and foot board to the frame was accomplished simply by inserting a 1-inch sheet of sponge rubber between the plywood board and steel disk and a 1/2-inch piece of gum rubber between the rotor-hub flange and the under side of the steel disk. The arrangement resembled a "shock mounting." A view of the underside is shown in figure 5. It permitted quick- or short-period control motions since the high-inertia part of the machine did not have to be moved when a control force was applied. The rubber gave the foot board a spring constant of 23 pound-feet per degree. The rotor-teetering spring restraint was used with this arrangement.

In all cases air was brought to the vehicle from a 25,000-cubic-foot, 200-pound-per-square-inch compressed-air tank through a 3-inch control valve, $1\frac{1}{2}$ -inch piping, a tee connection, two 1-inch flexible rubber hoses of equal length, and a tee connector at the hollow spindle, as indicated in figures 6 and 7. Air was introduced through two symmetrically arranged air hoses to prevent unbalanced hose forces.

In order to balance the torque reaction of the bearings and seal, 1/8-inch copper tubes carried air to two diametrically opposite points of the vehicle where the open ends of the tube were pointed in the direction opposite to the direction of rotation of the rotor. A small valve controlling the flow to this line was located at the flyer's right hip.

The flyer was provided with a safety harness consisting of a parachute harness attached at its shroud-line attachment points to rope suspension lines leading to an overhead ring. Four ropes attached to four points on the periphery of the circular tube surrounding the flyer also led to the overhead ring. Toe straps located the flyer's feet.

TESTS

Two flyers conducted the tests, and will be referred to as flyers I and II. These flyers were flyers B and C in reference 1. Consequently, they both had experience flying on a jet-supported platform before the present tests were initiated. Flyer I weighs 175 pounds and is 45 years old. Flyer II weighs 135 pounds and is 28 years old.

Tests were performed inside a building to obtain controlled conditions, and were made out of doors to determine the effects of wind.

The dimensions of the building enclosure are shown in figure 6. In the indoor tests the flyer and machine were located at the center of the enclosure while three test operators were located on a balcony. The air throttle was controlled by the first operator. An overhead hoist was controlled by a second operator to adjust the slack in the safety line during flight, and in certain cases to lift the vehicle to the desired starting altitude. A movie camera covering the flight was remotely controlled by a third operator.

Rotor speeds were measured during some of the tests by setting a microphone near the test vehicle. The microphone was connected to an oscilloscope which indicated the rotor-blade frequency. With flyer I on the vehicle, the rotor speeds varied from 1300 to 1500 rpm from take-off to 3 feet elevation. With flyer II on the vehicle, the rotor speed was varied from 1200 to 1400 rpm. Elevations refer to the height of the feet of the vehicle above the floor.

Indoor tests to determine flying qualities were performed from about 0 to 3 feet elevation with the rotor teetering. Tests from 0 to 6 feet elevation were performed with springs incorporated to restrain the rotor about the teetering axis. With the teeter-restraining springs installed, such translational tests as were permitted by the safety lines were made. Tests from 0 to 3 feet were performed with the teetering axis locked. In the above trials the flyers generally alternated - flyer I, then flyer II. Flight duration was usually 5 to 10 minutes, although some were shorter and some were as long as 15 minutes.

Out-of-door flight tests were made using an overhead horizontal cable, or high wire, about 20 feet above ground level as a safety line attachment. The air supply hoses were partially supported by rope attachments to the overhead cable. Anemometer records of the wind velocity encountered during the 4 days of outdoor testing are given in figure 8. On the first day, flights lasting about an hour at from 2 to 6 feet elevation were made with the flyer's back to light winds which varied from 4 to 8 miles per hour. The following day two flights totaling 25 minutes

were made at from 2 to 8 feet elevation facing into strong 8-to-31 mile-per-hour winds created by the passing of a cold front. The winds approached in an unobstructed sweep over several miles of marshland.

On the third day flights were made in order to compare again the relative merits of flying with and without rotor spring restraints after considerable experience in flying had been obtained. These flights were made at elevations of 2 to 7 feet in light winds.

On the fourth day flights were made with the sponge-rubber-mounted platform and rotor to determine the flying qualities of a machine with a low response time to a given foot control. Flights were made from 2 to 8 feet in gusty winds as shown in figure 8(d).

RESULTS AND DISCUSSION

Indoor Flights

Freely teetering rotor.- During initial flight trials with the rotor teetering it was noticed that, as soon as the feet of the vehicle cleared the ground the vehicle was quite steady, as though it possessed some form of stability. This effect was more pronounced when the rotor was locked to prevent teetering, as could easily be judged from the fact that a considerable shift in the flyer's body position, while causing a translational motion, would cause little tilting of the vehicle. During this condition, with the feet less than 6 inches above the ground, the rotor is less than two blade chords above the ground. This effect disappeared rapidly with altitude. It was noticed also that in quiet air with a given throttle setting the ground effect stabilized the altitude of the machine.

During initial flight trials it was noticed that the unbalanced torque on the vehicle was apparently quite small. The flyer could readily neutralize the torque by an adjustment of the valve provided for that purpose.

When the flight elevation was raised to approximately 1 foot with a teetering rotor, the existence of considerable horizontal gustiness was noticed. Such gusts would raise the level of the vehicle by 3 to 6 inches and disturb the balance. Under these circumstances the flyers seemed prone to overcontrol and continue cyclic oscillations. The gustiness appeared to be an interaction between the machine and the building; any control motion of the vehicle (tilting) would send the rotor wake more in one direction than in others. Presumably because of the building walls, the pilot and machine soon were subjected to a draft like a sudden horizontal wind. Opening the windows and door admitted a light breeze and appeared to diminish the gustiness to some extent.

At a test altitude of 3 feet, the gusty disturbances had partially disappeared. Any tilting motions of the machine appeared to be due to pilot action only. The ride was characterized by a steady downdraft, slightly noticeable on the hands and face, which was not noticeable at lower altitude. Under these circumstances the ride would at most times be characterized by overcontrol and insufficient damping as evidenced by cyclic oscillations of perhaps $\pm 2^\circ$ to 4° . It was therefore the opinion of both pilots, at the time, that the ride was marginal.

Spring-restrained rotor.- By the introduction of a rotor spring restraint about the teetering axis, it is possible to introduce a resistance to angular deflections of the platform. It was reasoned that some resistance to angular motion of the platform in any given control direction would introduce a beneficial "feel" to the platform. Also, since the rotor motion would lag the platform motion, the spring restraint should introduce damping to the platform.

The mechanical springs were installed and flights were made to and at about 12 to 18 inches. The gustiness at this elevation was still present and the balance of the vehicle under this condition resulted in considerable physical effort on the part of the flyer. When a horizontal gust would strike the machine the flyer would give a sharp control motion to counteract the side drift so introduced and several cyclic oscillations with a maximum amplitude of about 3° would follow. About 20 minutes of practice was required to learn to damp such disturbances out in about $1/2$ to 1 cycle. It was discovered at the same time that the effort to hold the machine at a given spot under gusty conditions was in large measure contributing to the oscillations. When the machine was allowed to drift a few feet the ride became quite smooth. Following this lead, translational flights at the same altitude were made back and forth in random directions with barely discernible oscillations. When the ride smoothed out the gustiness died down also, resulting in a pleasing ride.

Flyer I flew the machine with rotor spring restraint at 3- and 4-foot elevations for 15 minutes followed by a descent and smooth landing. Flight at these elevations was again characterized by a lack of gustiness and by a steady downdraft of air not felt at lower altitudes. He found the flight so easy to make at the 3- and 4-foot levels that it did not require his attention. He noticed a strong resemblance between this ride and the ride on the jet-supported platform which required no mental effort. Flyer II flew the machine at 3- to 4-foot levels for about 10 minutes and descended. Flyer II reverted to some overcontrol by ankle movements in the fore-and-aft direction as soon as he arrived at the 3- to 4-foot levels. After 2 or 3 minutes this tendency seemed to be mastered. The pictures in figures 7(a) and (b) show flyers I and II under the above-described flight conditions. Each flyer then made flights from 0- to 6-foot elevations and back down, slowly moving over the elevation range involved while maintaining the vehicle in the same lateral location.

It was now evident that satisfactory hovering flight on a propeller-supported platform had been made using the same balance principles as were used on the jet-supported platform.

Rotor locked.- Some flights made by flyer I with the rotor locked were very different. The vehicle would rise uneventfully with gradually opening throttle to a foot or more in altitude. As long as the pilot stood still and no particular gusty disturbance influenced the vehicle, nothing happened. However, if the flyer introduced a disturbance, say, by leaning slightly, the vehicle would go into a mild counterclockwise (the rotor was turning clockwise) precessional motion which was not unpleasant if the flyer would remain standing perpendicular to the machine, going along for the ride. The motion was like that of a top that leans and walks in a circle as it spins. The possibility of this result had been anticipated. If the flyer reacted to stop the motion without thinking, by leaning against the direction of the translational motion, the degree of tilt and speed of the motion would increase. However, by leaning radially outward, mild precessional motions could be started and stopped. One other pertinent point was noted; namely, that, if a substantial control moment was instigated by the operator, the vehicle had a distinct and even powerful resistance to the motion. If a strong control motion was used, annoying rotor vibrations were set up.

The principal information which was obtained concerning the locked rotor was: (1) the response to control moments was sufficiently out of directional phase to the control moments to require a different type of control than that required by a teetering rotor or by a jet-supported platform; essentially, the controls were crossed, and (2) the vehicle had powerful resistance to control. The response rate to a given applied moment was slow compared to the case with the teetering rotor.

Possibly the necessary method of control could be learned in a reasonable length of time, particularly since the response rate was slowed down. In fact, a beginning in this direction had been made. It was believed unwise, because of the possibility of developing conflicting habits, to continue with schemes requiring different systems of control. Experiments with the locked rotor were therefore discontinued.

Outdoor Flights

Spring-restrained rotor.- It appeared desirable to check the results obtained indoors under more realistic flight conditions. Flights were therefore continued out of doors. On the first day flights were made with a spring-restrained rotor at elevations from 1 to 6 feet. The wind was mild, varying from 4 to 8 miles per hour, as shown in figure 8(a). Horizontal gusts caused the machine to have a mild vertical oscillation of about 6 to 10 inches depending on their strength. The drift and oscillations set up did not seem excessive. Oscillations seemed to be damped

out in about $1/2$ cycle, while the drift was usually about 1 foot and at the most 2 feet. There seemed to be a little greater ease of flying at the 5- to 6-foot levels than at the 1- to 2-foot levels, but the air did not seem particularly gusty at the lower levels as it had indoors. Observers thought the rides appeared about equally smooth at all altitudes. There was a tendency for the flyer to be tense at the beginning of the flight, holding his feet and ankles rigid, but he would be relaxed by the end of the flight, and not tired. During these flights it was clear that when the rotor plane tilted as a result of a change in wind velocity the springs transmitted the tilt to the platform. This acted as a signal that a correction was required. A control force could then be applied before any appreciable drift built up.

On the morning of the second day, flights were made facing into the strong, gusty 8- to 31-mile-per-hour winds recorded in figure 8(b). The wind direction varied from straight ahead to 45° to the right of ahead. Flights from about 2 to 7 feet were made, hovering within about a 2-foot radius. Most disturbances were damped out in about $1/2$ to 1 cycle. The principal thing noticed by the flyer was that more weight was carried on the toes than in still air. This was particularly true when a strong gust would strike, lifting the front of the platform. While the flyer was airborne he shifted his feet about $1/2$ inch forward, which resulted in a reduced effort to maintain balance and position control. Apparently the tilting of the rotor plane relative to the platform plane by the wind velocity transmitted a moment to the flyer's feet that was equivalent to a small forward shift in center of lift. The tilting of the rotor plane was visible to observers at low rotor rpm, while the rotor was being brought up to speed. A picture sequence from this flight is shown in figure 9 showing one of the larger disturbances and the subsequent motion at 0.375-second intervals. Most of the balance was maintained with a fair degree of ease. Up to about 2 feet, changes in elevation were observed at a constant throttle setting due to changes in the strength of the wind. The shift in wind direction had no apparent adverse effect on the ease of balance and control.

Free teetering rotor.- On the third day, flights were made by flyers I and II to compare the flying qualities with and without spring restraint on the rotor. Without spring restraint, the rides were characterized by large body control motions and in some instances by undamped cyclic oscillations. The rides were uniformly good with the springs installed. Apparently the springs were reducing the flyer's time lag after a disturbance and introducing some damping.

A flight without springs using the hands on the hand rail was made by flyer I. This arrangement improved the controllability greatly. Satisfactory translations were made in random directions. The flyer's hands were used both as an assist to primary control in the action of shifting the body position and as dampers to the relative motion between the frame

and the flyer's body. Strong lateral oscillations of perhaps 10° with about a 2-second period introduced by pulling strongly with alternate hands could be stopped in 1 to 2 cycles. No rotor vibrations were felt.

Rubber-mounted rotor hub.- On the fourth day, flyer I flew using the alternate configuration which had the sponge-rubber mounting and rotor-teetering springs installed. The wind velocity shown in figure 8(d) was generally from the front, although observation of the anemometer wind-direction indicator showed changes in direction up to 60 degrees per second. A continuous half-hour flight included translations, with hands on and off the rail. With hands off the rail, the frame would follow the foot platform to some extent during a control motion with the feet. With hands holding the rail, even lightly, any motion between the flyer's body and the frame was eliminated. The ride with hands on the rail was therefore somewhat preferred. A strong resemblance to flight on the low-inertia jet-supported platform was evident. Control motions were both easy and quick and position control good. Flyer-platform disturbances were small in spite of rough air. The flyer did not tire. Considering the roughness of the air, this machine was the easiest to fly. Observers agreed the ride looked very well-controlled. This flight shows that the foot-platform control principle is not necessarily limited by the inertia of a vertically rising aircraft, but, if a control system is provided, is limited only by the control forces required by the controls.

Balance Techniques

Standing on a propeller-supported platform and standing on a jet-supported platform are both examples of a general class of vehicle in which the balance principle is that of standing on a thrust vector. With the experience of the present authors in flying both the above types, it seems in order to compare their characteristics and to discuss the techniques of balance.

The basic condition for balance, in the absence of aerodynamic forces other than thrust, is for the thrust axis to pass through the combined center of gravity of the vehicle and rider. If the vehicle is balanced, as has been approximately the case of the vehicles flown to date, the thrust axis passes through the center of gravity of the vehicle. To satisfy the basic condition for balance, then, requires that the thrust axis pass through the center of gravity of the flyer. If due to aerodynamic disturbances or movements of the flyer some unwanted position occurs, a righting moment may be set up by an action similar to standing on a level floor. If a man standing on a floor is leaning, he presses on the floor with his feet in a manner to bring him vertical. If a flyer and vector-supported platform are leaning the natural inclination of the flyer is to press on the low side of the platform to bring himself to a

vertical position. The moments so created rotate the flyer in the proper direction. The platform rotates in the opposite direction and swings the thrust vector to create an additional moment in the proper direction. The additional moment created by the movement of the platform can be powerful. The first thing the flyer learns in getting the feel of the platform, either with low or high inertia, is to make small control motions to prevent overcontrol and an accompanying angular momentum buildup of the platform and flyer. To do this he can either limit the magnitude or duration of the control motions. It has been demonstrated numerous times that the flyer does not need to understand the balance principles to fly. This is due to the fact that the action is qualitatively the same as standing on the ground. Quantitatively, standing on a vector-supported platform generally requires smaller or shorter-duration control forces for the reasons given above.

When overcontrol has been observed, it has been observed in the fore and aft directions; very seldom in the lateral direction. A stance is taken with the feet several inches apart and the flyer has very positive control over his lateral center-of-gravity position. If cyclic oscillations in the fore and aft directions occur, they occur in conjunction with bending motions of the ankle. If these occur excessively on a rotor-supported platform in calm air, or on a low-inertia jet-supported platform in any air, they are probably due to insufficient experience. However, if a large disturbance is encountered in the fore and aft directions on a large-inertia platform, the flyer is obliged to respond with a substantial control motion, and it is then more difficult to give the needed control, by the "ankle torque" technique just described, without applying it too long.

In distinction from the above-described method of balance, a valuable variation of the balance technique corresponds to the action any small boy or girl learns in walking on curbs or that is used by any person standing in a place with a narrow footing on which to brace the feet. It consists of a slight bending of the body at the waist. In this action, the center of gravity of the person, whether a curb walker or a flyer, is moved in the direction the waist and hips are moved. If a flyer and platform are leaning and the flyer wishes to be erect, he shifts his weight slightly toward the high side by a slight bend at the waist. The amount of waist movement may vary from an almost imperceptible amount on a jet-supported platform or rotor-supported platform in quiet air to an inch or more on a rotor platform in gusty air. With a little experience, the size of the control motion is adjusted to the particular disturbance. No differentiation is made between fore and aft and lateral controls. Rather, once the azimuth and magnitude of a disturbance is felt or noticed - usually as a tilting up of one edge of the vehicle - the waist is moved a commensurate amount in that direction. This technique appears to be the answer to overcontrol and oscillations either on the rotor- or jet-supported platform. Ankle motions are small and

passive, and smaller moments are transmitted through the ankles. This technique is also more conducive to relaxation than the first method described.

Comparison with Jet-Supported Platform

Since reference 1 was published, flights on a jet-supported platform were made out-of-doors. Figure 10 shows a typical flight on the jet-supported platform. The riders of such a vehicle had practically no difficulty with the wind. In calm air the rotor-supported vehicle hovers more steadily than the jet-supported vehicle. In gusty air the rotor-supported vehicle was more disturbed.

Noise levels were not measured, but the noise of the rotor with jets at the tip was not particularly objectionable. This compared to very objectionable noise levels on the jet-supported platform, necessitating the use of ear plugs.

CONCLUSIONS

Captive flight tests of a man standing on a teetering-rotor-supported platform resulted in the following conclusions:

1. The stability and controllability of a flyer standing on a spring-restrained teetering-rotor-supported platform were satisfactory.
2. The stability and controllability of a flyer standing on a free-teetering-rotor-supported platform were marginal. However, when a flyer with several hours of experience flew with his hands on a hand rail encircling the flyer, the ride was satisfactory.
3. By comparison with a low-inertia jet-supported platform previously tested, the teetering-rotor-supported platform flew steadier in calm air and with larger oscillations in gusty air.
4. Although the substantial inertia of the machine did not appear to be particularly critical, an arrangement in which the flyer's body moved with the frame and the low-inertia rotor and platform unit moved with the flyer's feet was physically easier to fly in rough air.

5. The ground effect not only gave altitude stabilization, but imparted an angular (pitch and roll) stabilization when the rotor was within about 2 blade chords of the ground.

Langley Aeronautical Laboratory,
National Advisory Committee for Aeronautics,
Langley Field, Va., February 9, 1954.

REFERENCE

1. Zimmerman, C. H., Hill, Paul R., and Kennedy, T. L.: Preliminary Experimental Investigation of the Flight of a Person Supported by a Jet Thrust Device Attached to His Feet. NACA RM L52D10, 1953.

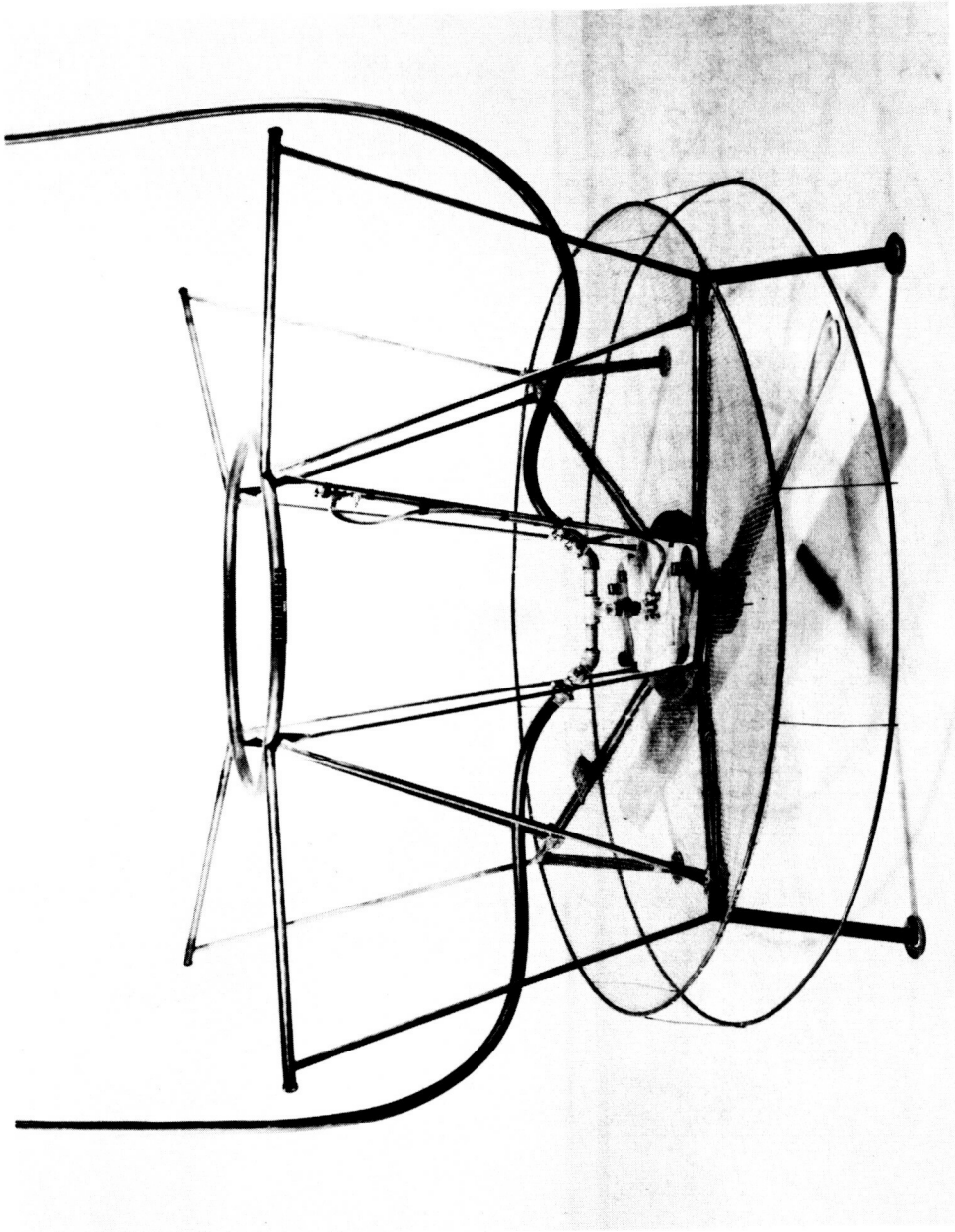

L-83387

(a) General view.

Figure 1.-- Photograph of test vehicle.

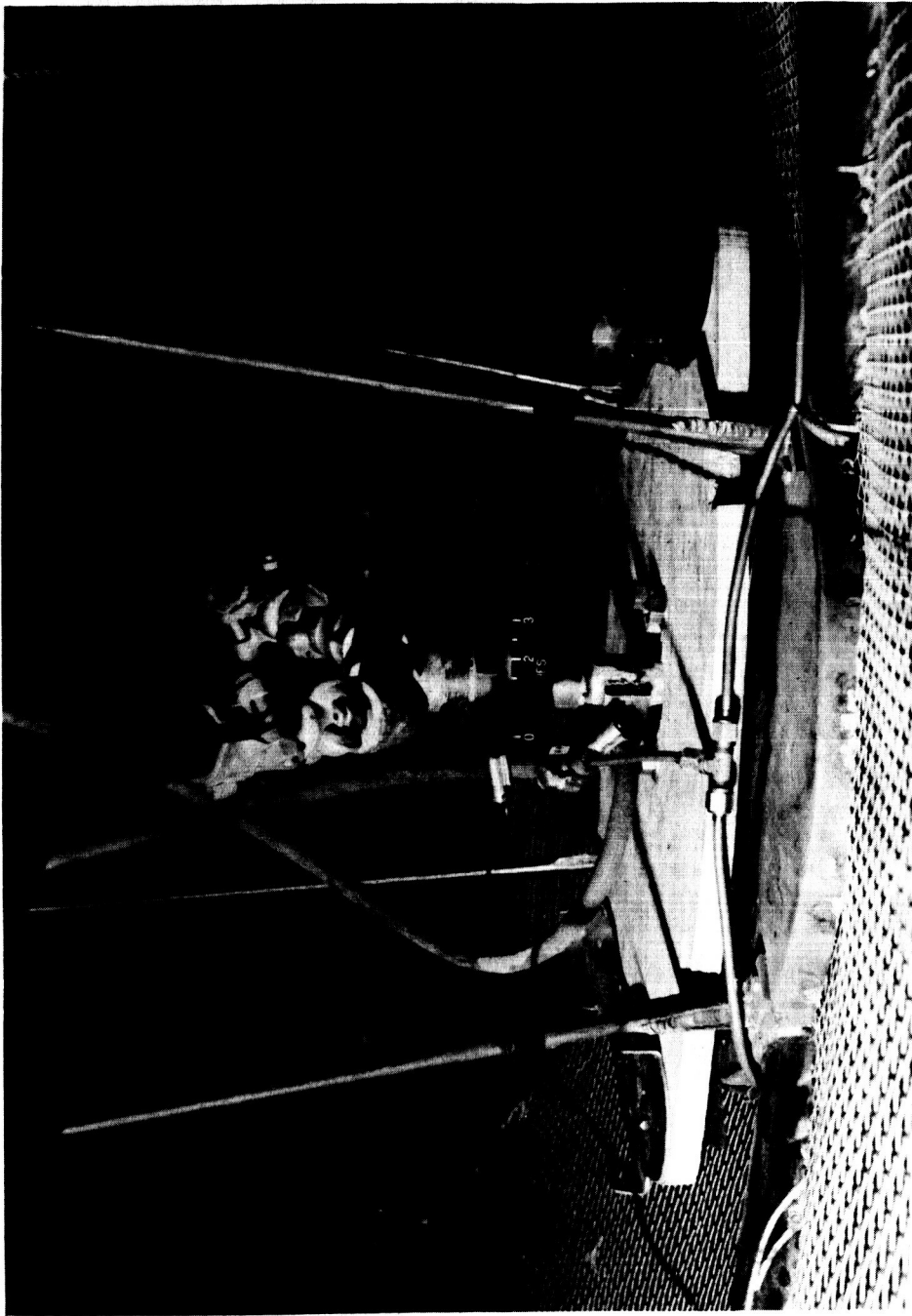

L-83164

(b) Detail of foot platform.

Figure 1.- Concluded.

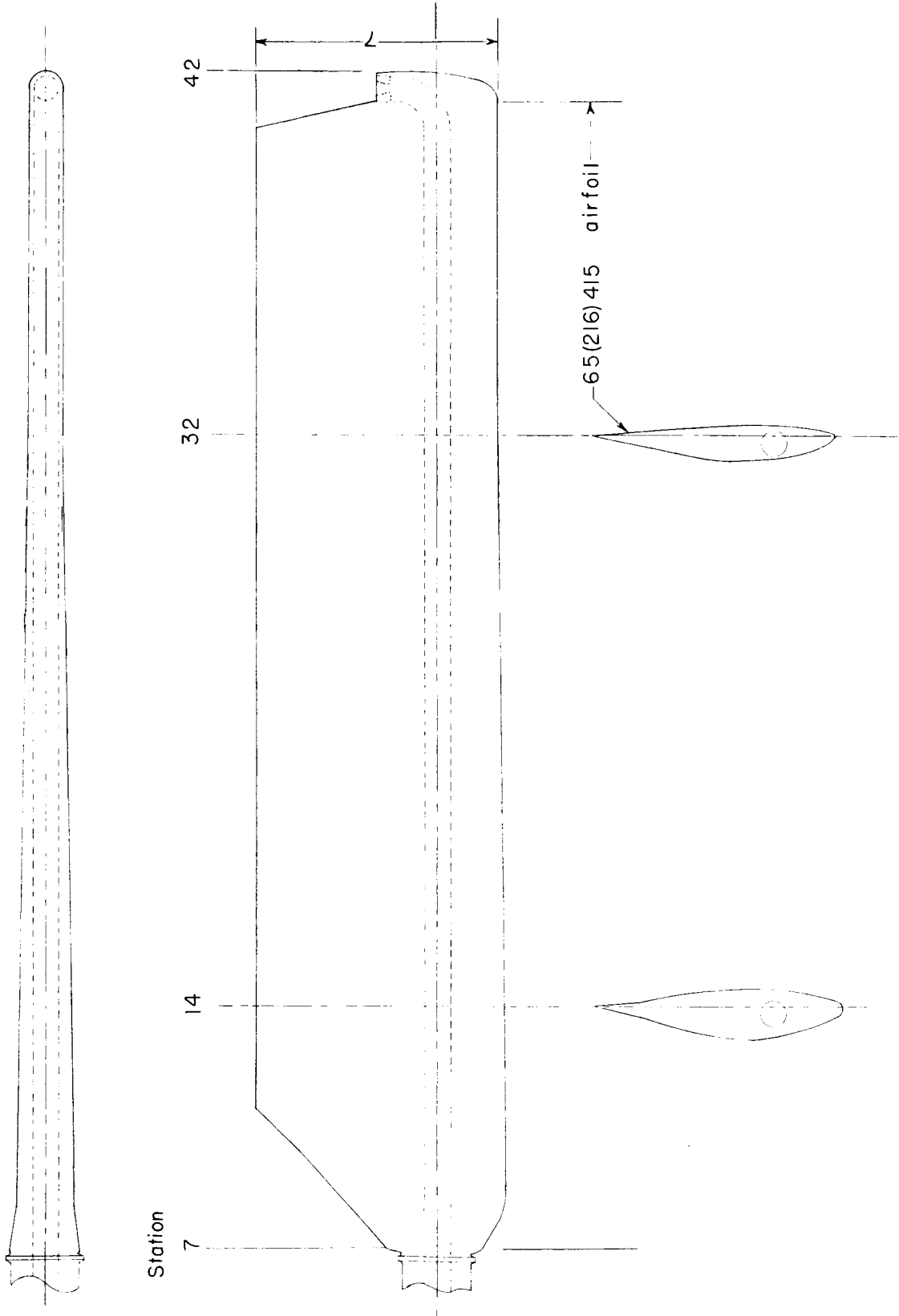
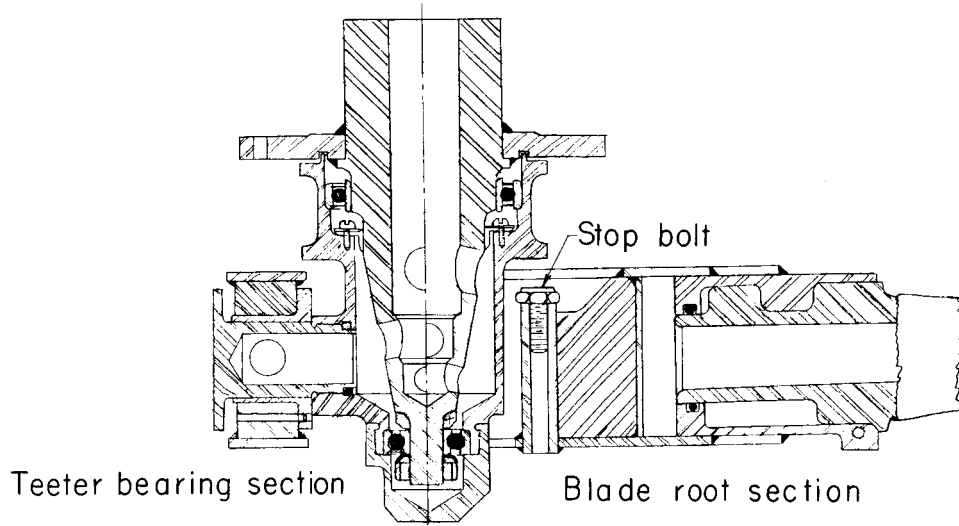

Figure 2.-- Sketch of rotor blade. All dimensions are in inches.



Section A-A

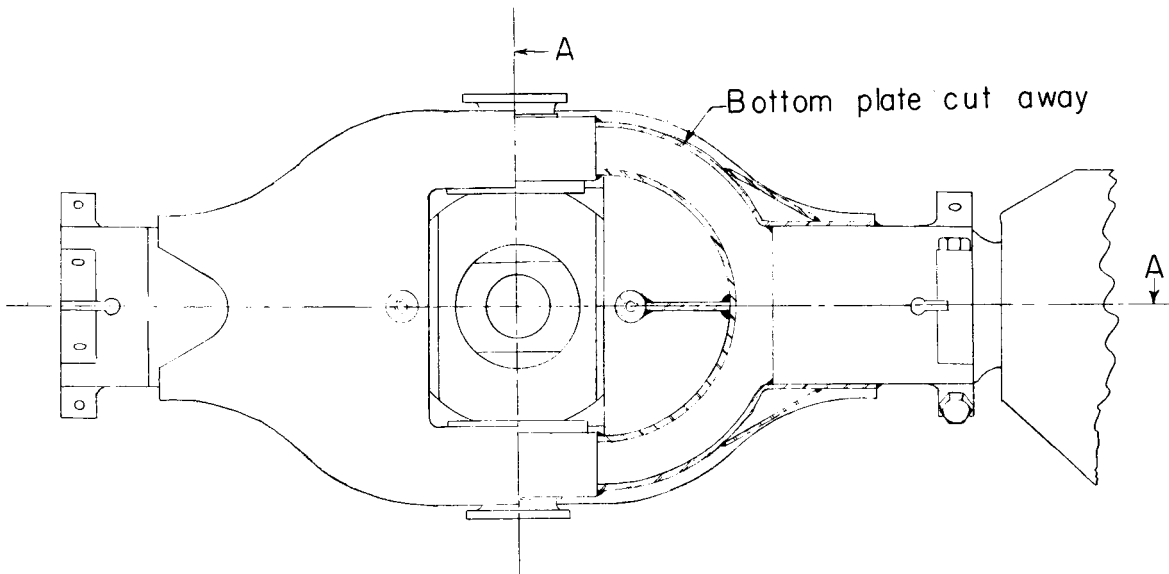
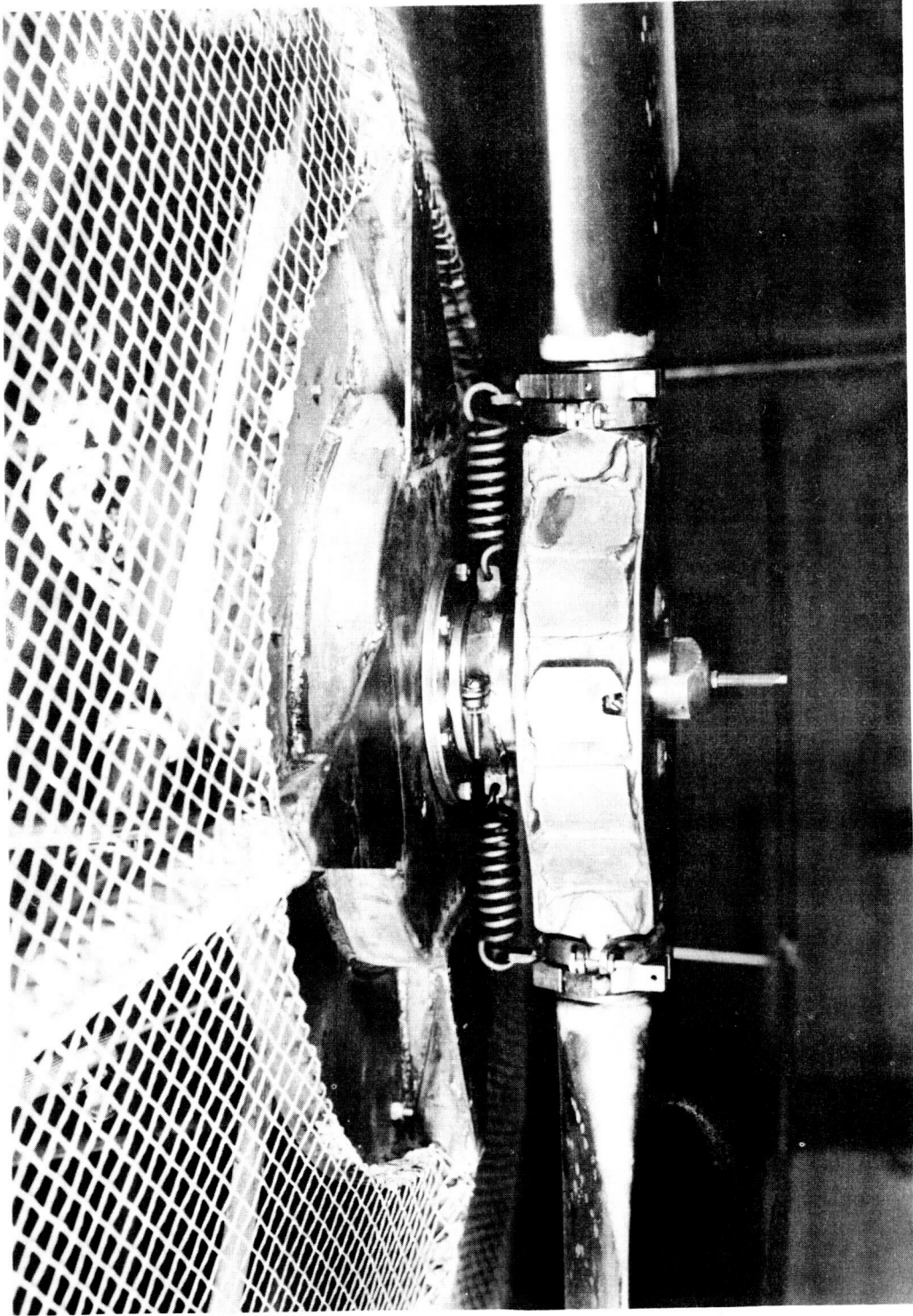
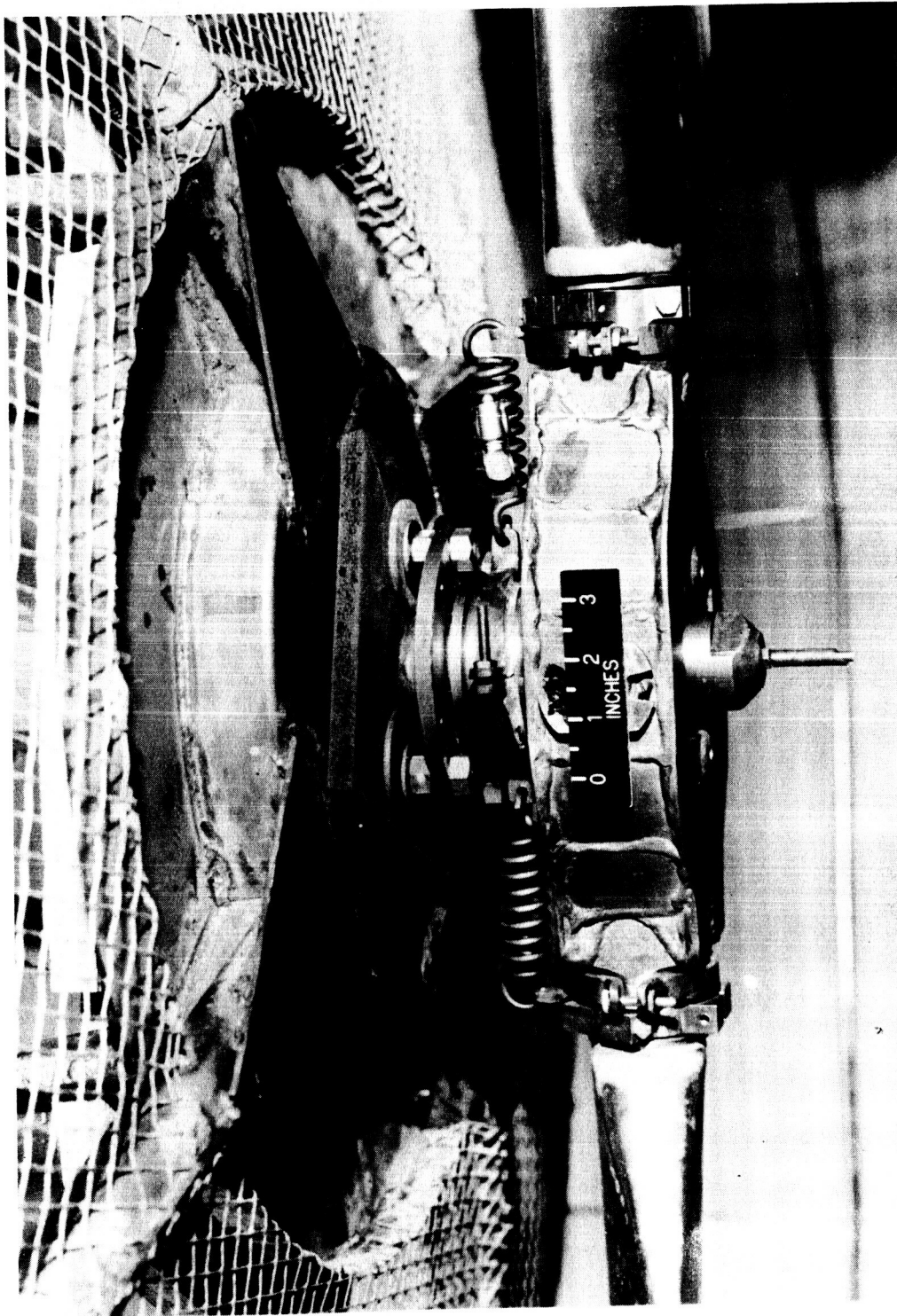

Figure 3.- Sketch of rotor-hub assembly.



L-83082

Figure 4.- Photograph of rotor hub with teeter restraining springs installed.



L-83163

Figure 5.- Photograph of rubber-mounted hub.

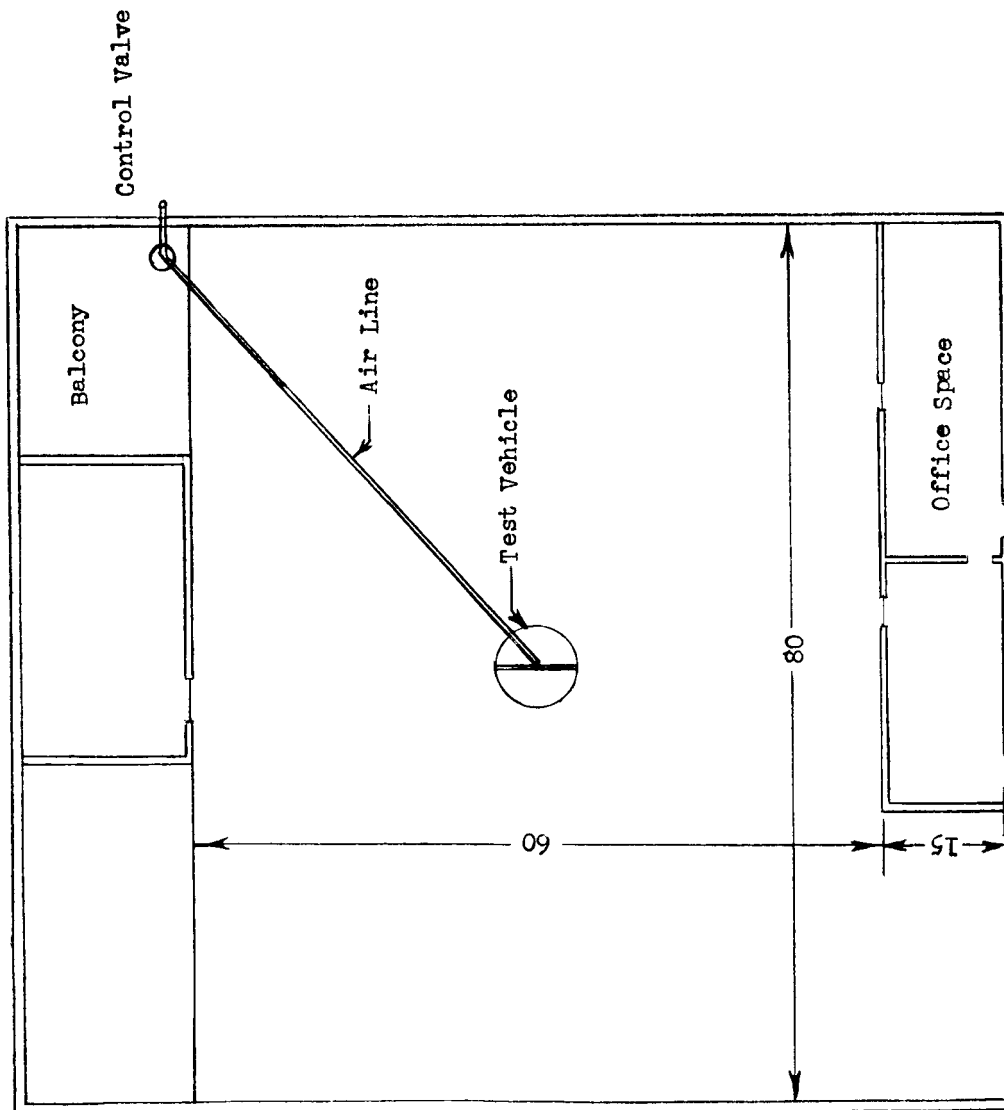
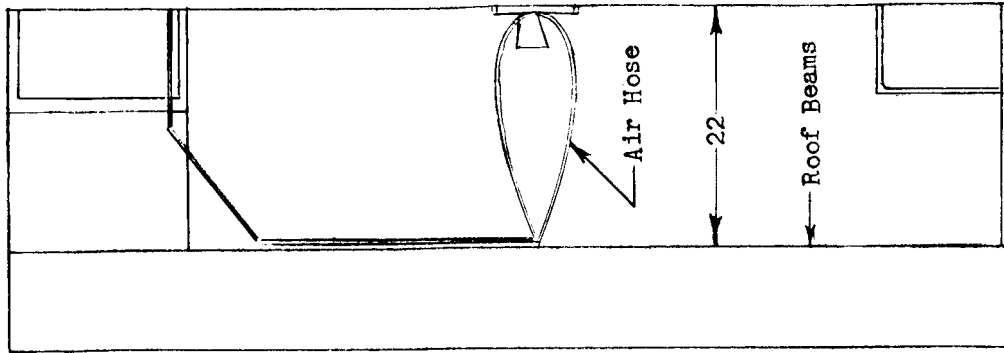
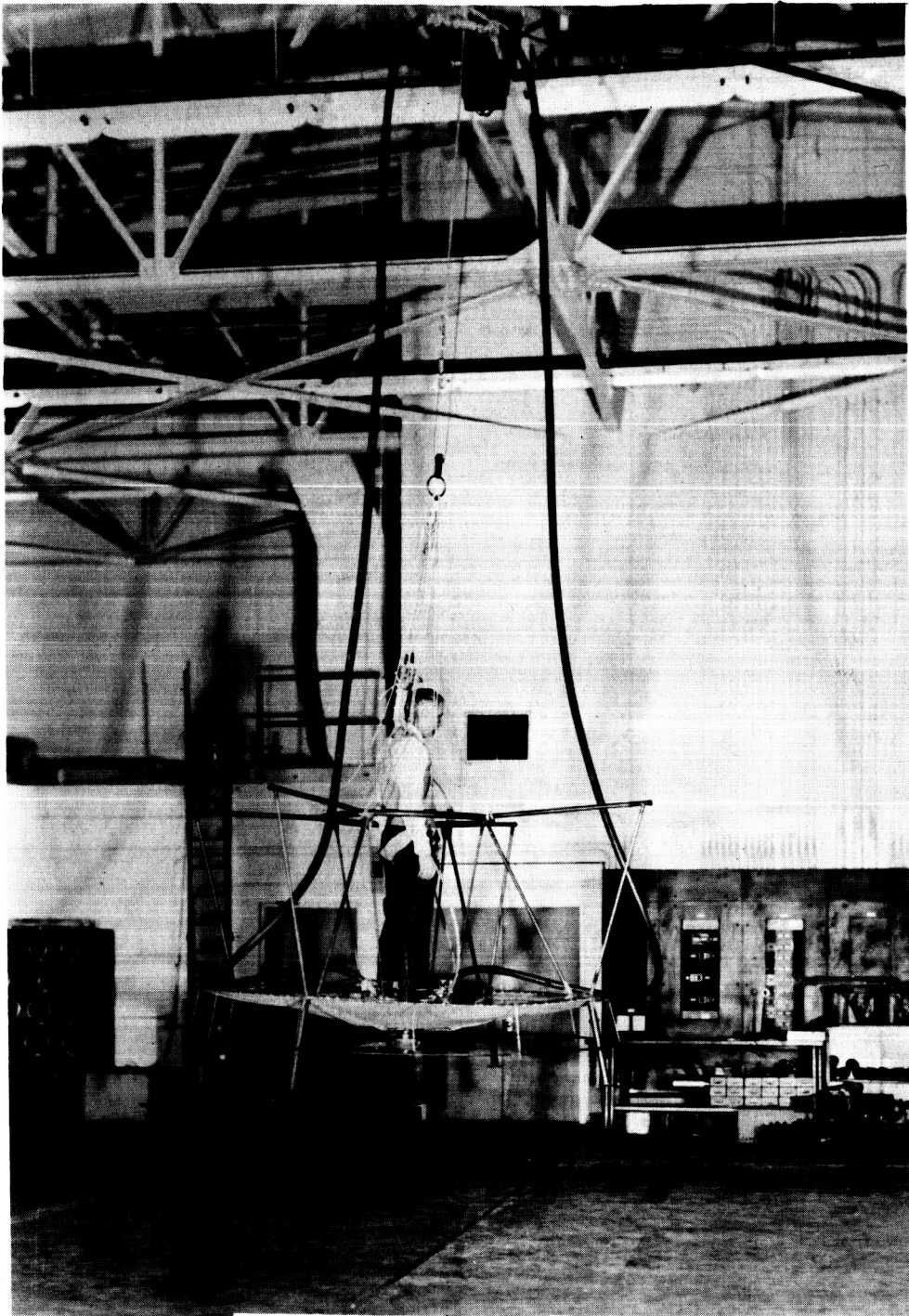

Figure 6.- Sketch of test room. Dimensions in feet.



(a) Flyer I.

L-82847

Figure 7.- Test vehicle in indoor flight.

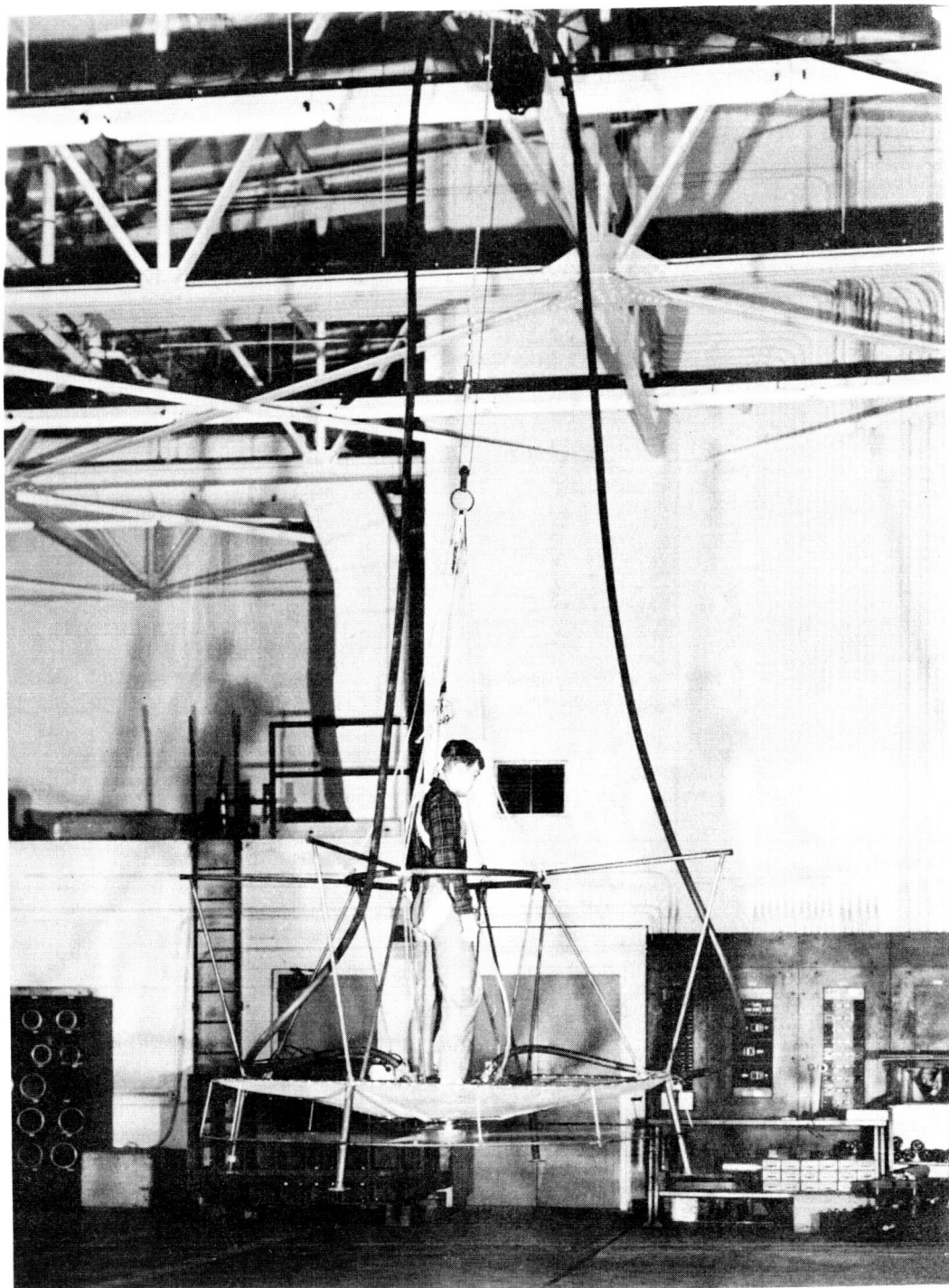

(b) Flyer II.

L-82846

Figure 7.- Concluded.

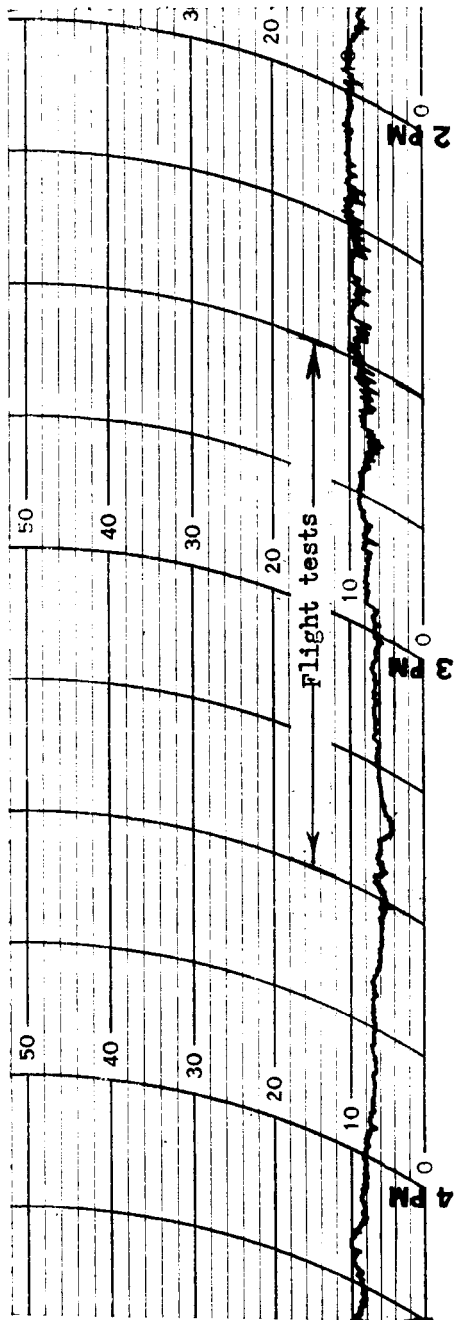

(a) First day.

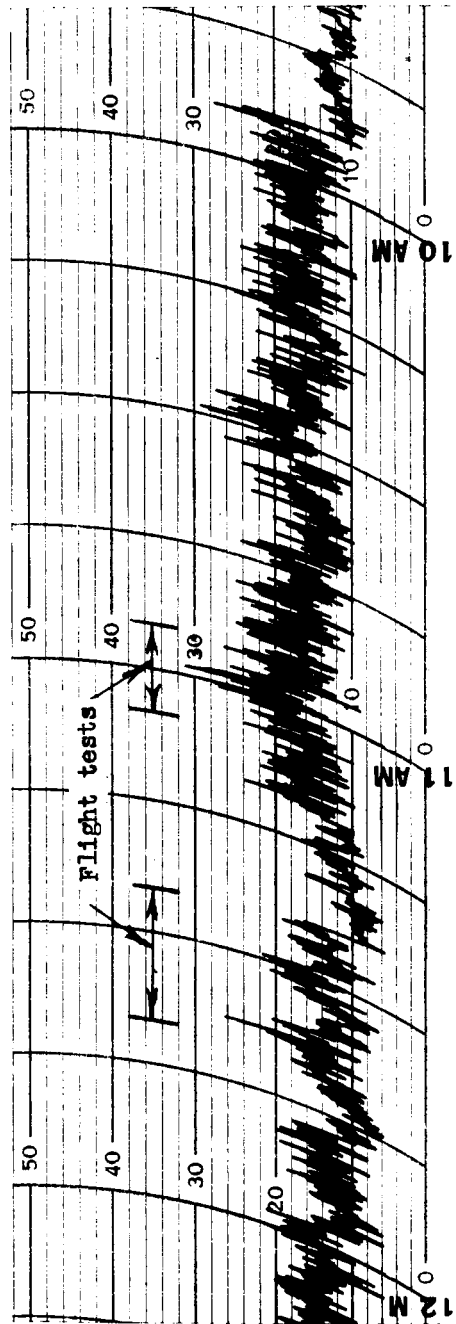

(b) Second day.

Figure 8.- Anemometer wind-velocity records. Velocity in miles per hour.

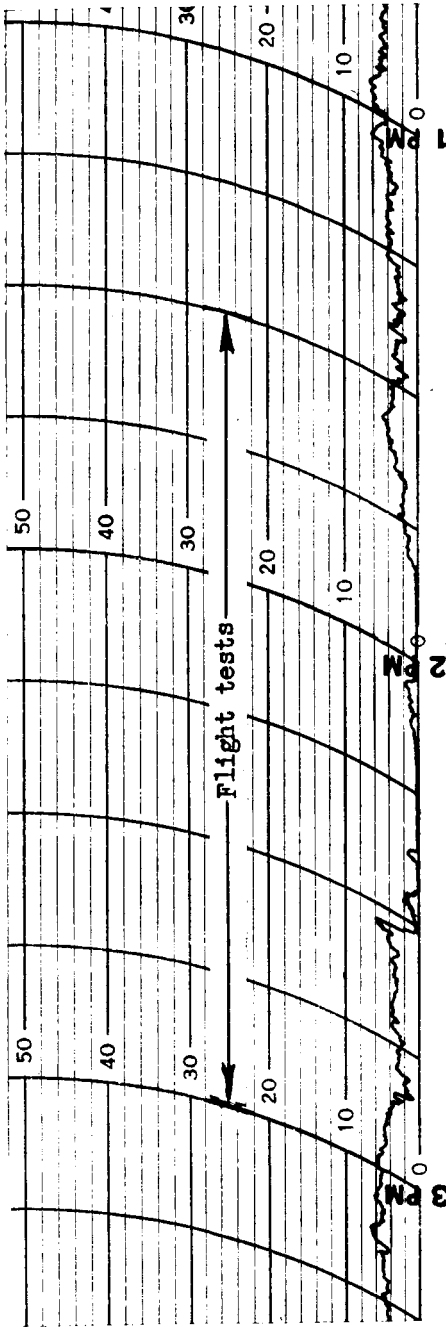

(c) Third day.

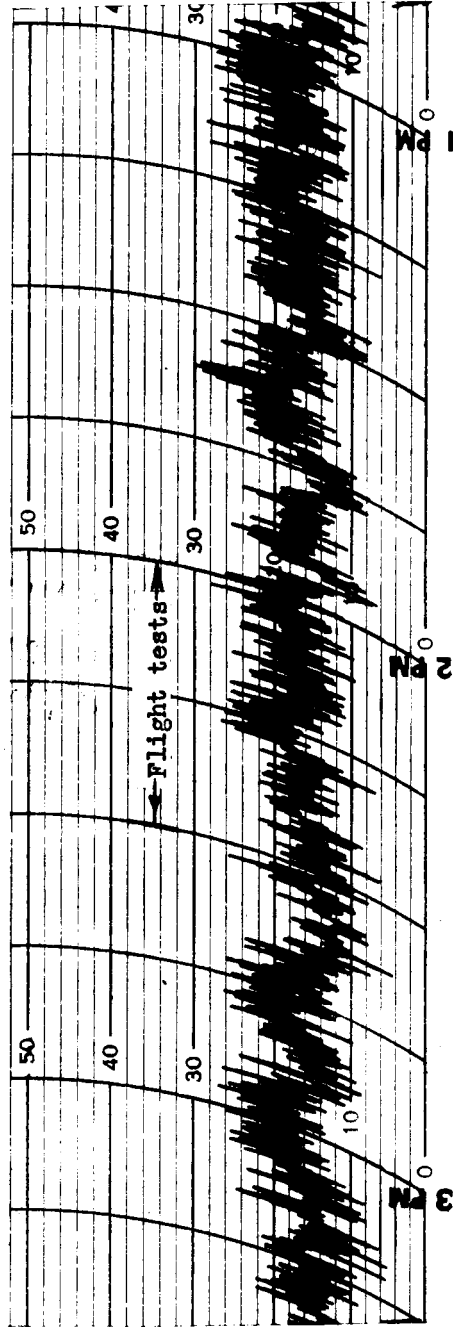

(d) Fourth day.

Figure 8.- Concluded.

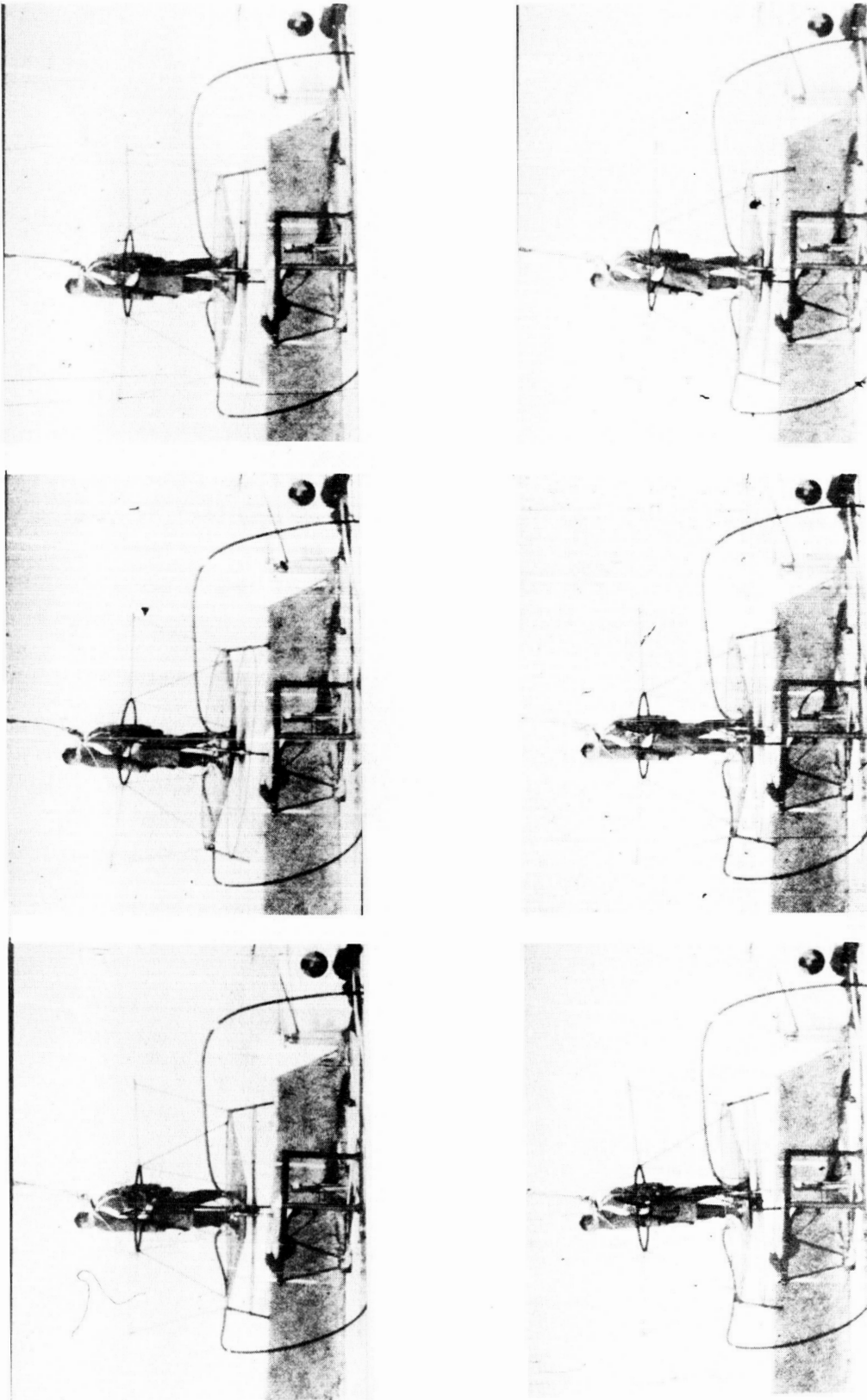

L-83308

Figure 9.- Sequence showing typical outdoor flight.

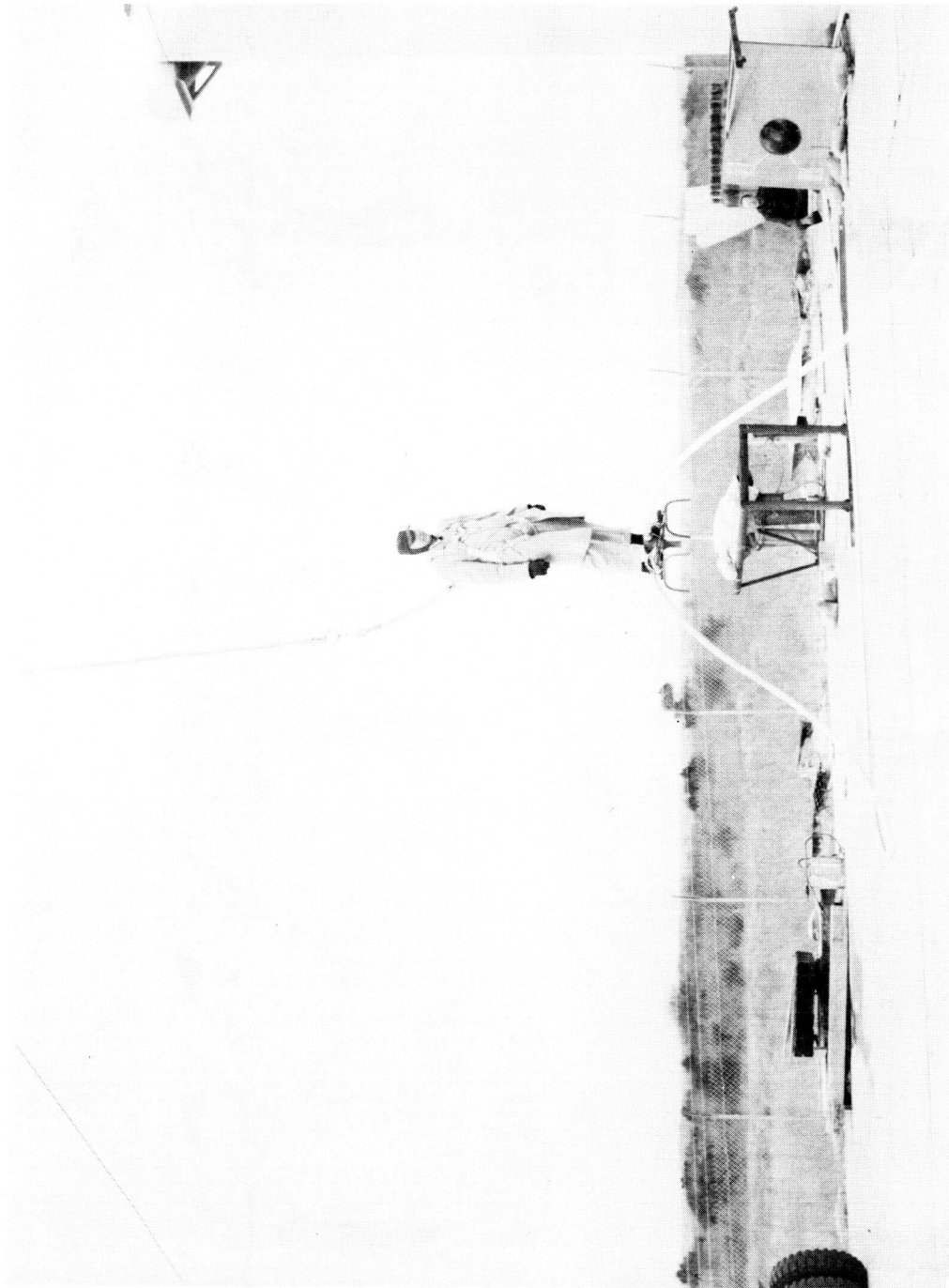

L-83076

Figure 10.- Photograph of flyer I in outdoor flight on jet-supported platform.