

PERMANENT FILE COPY

ANNOUNCEMENTS NO. 7
Date 6/30/59 By [Signature]

NACA

RESEARCH MEMORANDUM

DESIGN AND PERFORMANCE OF FUEL CONTROL FOR AIRCRAFT
HYDROGEN FUEL SYSTEM

By Edward W. Otto, Kirby W. Hiller, and Phil S. Ross

Lewis Flight Propulsion Laboratory
Cleveland, Ohio

CLASSIFICATION CHANGE

To: Unclassified
By authority of NASA Memo dtd 5-2-73 / by H. Maines
Changed by M. Buda Date 6-6-73

CLASSIFIED DOCUMENT

This material contains information affecting the National Defense of the United States within the meaning of the espionage laws, Title 18, U.S.C., Secs. 793 and 794, the transmission or revelation of which in any manner to an unauthorized person is prohibited by law.

NATIONAL ADVISORY COMMITTEE FOR AERONAUTICS

WASHINGTON

August 19, 1957

FILE COPY

To be returned to
the files of the National
Advisory Committee
for Aeronautics
Washington, D. C.

SECRET

NATIONAL ADVISORY COMMITTEE FOR AERONAUTICS

RESEARCH MEMORANDUMDESIGN AND PERFORMANCE OF FUEL CONTROL FOR
AIRCRAFT HYDROGEN FUEL SYSTEM

By Edward W. Otto, Kirby W. Hiller, and Phil S. Ross

SUMMARY

The system analysis, design, and performance of a control system for an experimental flight-type hydrogen fuel system are presented. The fuel system was designed to investigate some of the problems associated with the utilization of hydrogen as an aircraft fuel. Hydrogen was carried in the fuel tank as a cold liquid, vaporized in a heat exchanger, and injected into the combustion chamber as a gas. The fuel was forced through the system by pressurizing the tank. The type of control that appeared most capable of coping with the characteristics of this system was a flow regulator. The flow regulator designed for the system was a differential reducing-valve type.

Speed control of the engine was obtained by coupling the hydrogen regulator to the JP-4 fuel control. Because the hydrogen regulator was designed for high dynamic response, the performance of the complete speed-control system was essentially the same on hydrogen as on JP-4 fuel.

INTRODUCTION

Among the attractive features of hydrogen as an aircraft fuel are its potentialities for increasing the altitude and range of aircraft and as a heat sink for cooling aircraft and engine components during high-speed flight (ref. 1). The greatest disadvantage of hydrogen as an aircraft fuel is its low density. Even in the liquid state hydrogen occupies a much larger volume than an equivalent amount (in heat content) of JP-4 fuel. For this reason a flight plan that calls for the use of hydrogen only at high altitudes where the fuel requirements are low appears the most feasible at present. Such a flight plan calls for takeoff and climb on JP-4 fuel. In this way operation on hydrogen for a reasonable length of time can be provided without prohibitive volumes.

One of the objectives of a program undertaken to investigate the use of hydrogen as an aircraft fuel was to study some of the problems that

occur in such a fuel system in an airplane in flight. With respect to fuel control the investigation presented two interesting problems. First, the use of dual fuel systems appeared to warrant the study of an integrated control system that would be compatible with both fuels and could switch between the two fuels without excessive transients. Second, the hydrogen fuel system employed as a heat sink incorporates a heat exchanger or vaporizer and injects the fuel into the engine as a gas, factors which are not present in the JP-4 fuel system. Preliminary ground studies indicated that this system was in some cases unstable, the instability being characterized by a slow surging oscillation in gas flow (ref. 2).

A flight investigation of a heat-sink type hydrogen fuel system was accomplished by installing the necessary components on one engine of a twin-engine high-altitude medium bomber. The JP-4 fuel system for this engine was left intact and provisions for switchover from JP-4 fuel to hydrogen fuel at the intended altitude of the investigation were provided. Prior to the installation of the fuel system in the aircraft, the complete system and component parts were investigated in an altitude test chamber (ref. 3). The results of the flight of the aircraft on hydrogen fuel, which was successful, are presented in reference 4.

This report discusses the influence of the characteristics of the fuel system, the control requirements of the engine, and the control requirements of the flight plan on the type of control selected and its design. Also discussed are some construction details and the general performance of the control.

CONTROL-SYSTEM ANALYSIS

Hydrogen Fuel System

A schematic drawing of the hydrogen fuel system used for both the altitude-test-chamber studies and the flight tests is shown in figure 1(a). The system consists of a fuel tank, a vaporizer-type heat exchanger, a regulator, and a fuel-injection system. The tank is filled with liquid hydrogen at atmospheric pressure (temperature, about 40° R). It is then pressurized with gaseous helium at a pressure of about 55 pounds per square inch absolute to provide a source of liquid hydrogen at sufficient pressure to overcome all the system pressure losses and to accomplish injection into the combustion chamber. The tank and its installation are described in reference 4.

A schematic diagram of the vaporizer is shown in figure 1(b). The exchanger was designed to vaporize the fuel through the heat obtained from the flow of ram air at altitude across the finned tubes. Liquid hydrogen was introduced at a header at the bottom and gaseous hydrogen at approximately 60° R was available at the top header. The vaporizer-type heat exchanger is described in detail in reference 5.

The fuel-injection system consisted of 36 tubes (1/4-in.) fed from a common manifold. Each of these tubes introduced gaseous hydrogen into the vaporizer tubes of the combustion chamber (fig. 1(c)). The injection system is described in reference 3.

The characteristics of the fuel system that are important with respect to flow regulation are the pressure-flow characteristics. A schematic representation of these characteristics is shown in figure 2. The line labeled "combustion-chamber pressure" is characteristic of the steady-state compressor-discharge pressure plotted against the engine fuel flow. The line labeled "manifold pressure" represents the pressure drop in the injection system added to the compressor-discharge pressure. The line labeled "supply-system pressure" is the pressure to which the fuel tank is subjected. The supply-system pressure line is shown with a slight decrease with increasing flow, which represents the characteristic of the regulator applying the helium pressurizing gas plus the friction losses in the piping and the heat-exchanger loss. The difference in pressure between that available from the supply system and that required at the manifold at any given flow is the pressure drop available for flow control.

Control Requirements

In a simple system, flow control normally would be obtained by inserting a throttling valve in the line. However, in previous experiments (ref. 2) with this type of fuel system, flow instabilities of a slow surging nature were encountered. In a low-resistance system such as this one, the inherent flow regulation is poor. Thus, disturbances (such as a variation in the energy-release rate in the vaporizer, which depends on liquid level, flow rate, and so forth) manifest themselves as flow variations in the system. This characteristic of the fuel system requires a control incorporating flow regulation.

Other characteristics of the fuel system that complicate the control requirements are the variations in the pressure-flow characteristics of the components of the fuel system. For example, the injection-system pressure-flow characteristic varies markedly with variation in temperature of the fuel, which at this point in the system is in a gaseous state. Such variations in the pressure-flow characteristics of the fuel-system components require a type of control that is independent of the variations.

The engine used in the flight tests was of a type utilizing an axial-flow compressor, an annular vaporizer-type combustor, a two-stage turbine, and a fixed-area exhaust nozzle. In an engine of this type, the control requirements are the prevention of overspeed, overtemperature, compressor surge, and combustor blowout. When using hydrogen as a fuel,

these same requirements apply except that the requirement on the minimum fuel flow to prevent blowout can be greatly relaxed for hydrogen because of its much wider flammability limits (ref. 6). In the conventional JP-4 fuel engine control, overspeed, overtemperature, and surge prevention are obtained by the use of an overspeed governor and a fuel-flow schedule. The use of a fuel-flow schedule necessitates the measurement of fuel (hydrogen) flow. This requirement again suggests the use of a flow-regulator type of control in the hydrogen fuel system.

Because of the requirements of the flight program, it was desirable to incorporate a type of control system that would give automatic control of engine speed and that could be switched from the regular fuel to hydrogen without excessive transients. The requirement of a closed-loop speed control would make it necessary to regulate fuel flow on the gaseous side of the vaporizer because the large energy-storage capacity of the vaporizer would introduce such a long time constant that closed-loop operation of an engine-speed control would be very slow compared with that obtainable with the JP-4 fuel system.

CONTROL SELECTION

Much of the preceding discussion on control requirements indicates the desirability of using a flow regulator in the hydrogen fuel system. Furthermore, a flow regulator appeared necessary to combat fuel-system instabilities. It also has the desirable feature of being insensitive to variations in the fuel-system-component characteristics and is amenable to a fuel-flow schedule for prevention of overtemperature and surge. Other requirements have indicated that a speed-control system is desirable. Because the regular engine control is a speed-control system and contains the fuel-flow schedule for surge prevention, it seemed desirable to utilize as much of the existing control system as possible. This was accomplished by constructing the hydrogen flow regulator as a ratio control device, that is, such that it controlled the weight flow of hydrogen in a fixed ratio to the weight flow of JP-4 fuel from the engine-speed control. During operation with hydrogen in such a system the JP-4 fuel flow from the engine control was not injected into the engine but was diverted back to the fuel tanks after passing through its part of the hydrogen regulator. The flow ratio was the inverse ratio of the heating value per pound of the two fuels.

The use of a regulator of this nature in conjunction with the engine-speed-control system added another dynamic element in the JP-4 fuel speed-control loop. In order to avoid reducing the control-loop gain, which would reduce the transient performance with either fuel, it was necessary to make the hydrogen regulator in the order of 10 times faster than the engine, which is the slowest element in the loop. Also, it was necessary to keep the volume of the hydrogen manifold small, so that the lag essentially defined by its filling time would be small compared with the engine-speed lag.

The type of flow regulator selected for the hydrogen fuel system was a differential reducing valve. This regulator controls flow by maintaining the pressure drop across an orifice in response to an outside command through the variation of a valve in series with the orifice. This type of regulator is insensitive to upstream or downstream pressure variations within its range and can be made reasonably fast acting. It was coupled, as previously described, to the regular engine control by passing the JP-4 fuel from the JP-4 fuel control through a device that produced the flow command signal for the hydrogen flow regulator.

DESCRIPTION AND CONSTRUCTION DETAILS OF CONTROL

The differential-reducing-valve flow regulator used (fig. 3) consists of a piston, or diaphragm, subjected to the pressure drop across the flow-measuring orifice and the force from the outside command, and is coupled to a valve in series with the flow-measuring orifice. Any unbalance of forces will cause the assembly to move until force equilibrium is obtained. Thus, a pressure drop across the orifice is set up for every value of command force. However, the equation for flow through an orifice also involves the gas density as follows:

$$w \approx A\sqrt{\rho\Delta P} \quad (1)$$

where w is weight flow, A is orifice area, ρ is density, and ΔP is the pressure drop across the orifice. A gas-filled bellows is sensitive to the pressure and the temperature of its environment and produces a displacement which is approximately proportional to the gas density. When the movement of such a bellows is used to vary the orifice area A in the fashion $1/\sqrt{\rho}$, equation (1) becomes

$$w \approx \sqrt{\Delta P} \quad (2)$$

Because the action of the regulator is to produce a ΔP for every command force F applied, equation (2) may be written

$$w \approx \sqrt{F}$$

Thus, a weight flow of hydrogen gas is obtained for each force applied, and this flow is independent of variations in upstream or downstream pressure.

This differential reducing valve is converted to a device that controls the ratio of flow of hydrogen gas to the flow of JP-4 fuel by coupling it to a device that produces a force as a function of the flow of JP-4 fuel. The flow of JP-4 fuel is passed through an orifice and the resulting pressure drop is imposed across a diaphragm to produce a force that is a function of JP-4 fuel flow as follows:

$$w_{JP-4} \approx \sqrt{F_{JP-4}}$$

This force is then imposed on the hydrogen regulator to control the weight flow of hydrogen gas in a constant ratio to the flow of JP-4 fuel. The numerical value of the ratio is matched to the ratio required by the heating values of the fuels by suitable selection of orifice areas, piston or diaphragm areas, and the force-equating linkage ratio.

A schematic drawing of the layout of the ratio regulator is shown in figure 4(a), and a sectional drawing is shown in figure 4(b). The JP-4 fuel orifice consists of an annular clearance between the JP-4 fuel piston and the cylinder wall. The force obtained from the JP-4 fuel piston is transmitted through the pivoted lever assembly to the hydrogen piston system. The hydrogen orifice is composed of the clearance between the piston and the wall, and the valve varied by the density-compensating bellows. The reducing valve is an integral part of the piston assembly and is a pressure-balanced type.

The hydrogen regulator housing and piston and the connecting lever are all type 347 stainless steel. The density-compensating bellows and the sealing bellows are brass. All parts associated with the bellows were made of brass so that soft-solder sealing could be used. The other parts in the hydrogen regulator are brass. The JP-4 fuel piston housing is aluminum alloy, and the JP-4 fuel piston and shaft are stainless steel.

Both piston assemblies are mounted on linear ball bearings in order to keep friction as low as possible. The clearances and concentricities of these assemblies are such that no sliding friction is involved. The cross-lever pivot bearing is a needle bearing. All bearings operate with whatever lubrication their respective fluid environments can provide.

Relatively high-resistance heat-leak paths between the hydrogen and JP-4 fuel sides of the regulator are provided so that JP-4 fuel is not solidified. In the mounting bracket that connects the two units together, this is accomplished by reducing the cross-sectional area of the mounting bracket to a minimum. In the lever assembly the two sets of bellows with their large surfaces help conduct heat into the relatively quiescent fluids surrounding the lever.

Moving seals, such as around the lever assembly, were formed by brass bellows soft-soldered to the corresponding parts. Stationary seals were formed by narrow soft-aluminum gaskets. Stationary seals were incorporated at the point where the lever-assembly bracket attaches to the hydrogen valve housing and at the two end flanges of the housing.

GENERAL PERFORMANCE OF CONTROL

The steady-state and transient characteristics of the ratio regulator were determined from bench tests, and the performance in the engine-speed

loop was obtained from an altitude-test-chamber evaluation of the engine and hydrogen fuel system. The bench test data were obtained using air at ambient temperature instead of hydrogen gas at the design temperature of 60° R. Because the density compensation bellows was designed to operate in the 40° to 200° R region, it was inoperative at the bench test temperatures. Thus the bench data present only the ability of the regulator to regulate the pressure drop across the metering orifice. With perfect density compensation assumed, these data indicate the ability of the control to regulate gas flow.

Steady-State Response

The steady-state response of the ratio regulator is defined essentially by its ability to hold the flow ratio constant in spite of variations in upstream or downstream pressure and independent of the absolute level of JP-4 flow. Bench test data are summarized in figure 5 to show the variation of metering orifice pressure drop at several percentages of rated JP-4 fuel flow as a function of inlet pressure in figure 5(a) and discharge pressure in figure 5(b). These curves indicate the ability of the regulator to control the pressure drop across the metering orifice to the desired value in spite of upstream or downstream pressure variations. If perfect density compensation is assumed, they also indicate the ability of the regulator to control the gas flow as a function of JP-4 fuel flow and independently of inlet or discharge pressure. Although the flow ratio maintained by the regulator over the series of JP-4 fuel flows is not shown as such, its relative value may be obtained by comparing the flow percentages of the JP-4 fuel flow and the hydrogen flow.

The reducing valve used was not a tight shutoff valve, but was designed for good control characteristics. It therefore permitted a flow of gas at its minimum-area position. These curves are labeled "valve closed" in figure 5. Conversely, there is a maximum valve area, and this area in series with the orifice will define a maximum-flow curve. This curve is labeled "valve open" in figure 5. Because the valve can open to a wider area than the orifice, this curve is essentially the orifice pressure-drop characteristic.

The most probable operating pressures for the manifold are also shown in figure 5(b). The position of this curve on the operating map of the regulator indicates that rather large changes in the manifold pressure characteristic can be permitted without changing the flow delivered by the regulator. With the manifold pressure characteristic in the position shown on figure 5(b) the pressure drop across the regulator at 100 percent rated JP-4 fuel flow is approximately 20 pounds per square inch gage and the discharge pressure is approximately 10 pounds per square inch gage. The characteristics shown in figure 5(a) for atmospheric discharge are also approximately the same for discharge pressures from 1/2 to 2 .

atmospheres. Thus, the ordinate may be considered equal to the pressure drop across the control. For operation with pressure drops near 20 pounds per square inch the flow delivered by the regulator is insensitive to variations in upstream pressure.

The flow range of this regulator cannot be considered large; however, it was designed to operate principally at one condition. Extending the range is primarily a matter of reducing the valve leakage. Another method, which has less effect, is to operate with a lower orifice pressure drop. This method unfortunately reduces the operating forces in the regulator so that trouble may be encountered with random effects such as impurities of a solid nature. The range can be extended almost without limit by referencing the tank pressure regulator, which sets the supply pressure, to the pressure downstream of the reducing valve. Thus, there will be a relatively constant pressure drop available for the reducing valve. On figure 2 this procedure would change the supply pressure line to a position approximately parallel with the manifold pressure line.

Transient Response

The dynamic characteristics of the regulator can be described by three transfer functions: hydrogen gas flow as a function of (1) JP-4 fuel flow, (2) inlet pressure, and (3) outlet pressure. The first transfer function, hydrogen gas flow as a function of JP-4 fuel flow, defines the dynamic ability of the regulator to change the hydrogen flow in response to changes in JP-4 fuel flow. The second and third transfer functions describe the ability of the regulator to hold the hydrogen flow independent of perturbations in either supply or discharge pressure.

For small perturbations this regulator can be considered linear. Because all three inputs manifest themselves as forces on the moving assembly, the same break frequency will apply to all transfer functions. Thus, the dynamic characteristics can be sufficiently described by obtaining one of the transfer functions. The transfer function of hydrogen gas flow to JP-4 fuel flow is the one most important to the stability of the speed-control loop.

Figure 6 is a plot of bench test data, which show the amplitude and phase characteristics of hydrogen gas flow to perturbations of ± 10 percent in JP-4 fuel flow at rated flow. In view of the absence of strong enough trends to indicate a more complicated response, the system must be described as first order with a break frequency of approximately 6 cycles per second. There is some evidence from the amplitude response that the spring and mass system formed by the piston and sealing bellows assembly is affecting the response near 12 cycles per second, but the phase data do not indicate a second-order response. The calculated value of the spring and mass resonant frequency is in the region of 12 cycles per

second but varies because of the nonlinear spring rate set up by the direction in which the sealing bellows are deflected.

The important aspect of this transfer function is that the break frequency is of the order of 100 times the engine break frequency at the altitude of operation. Thus, the ratio regulator will have practically no effect on the dynamics of the engine-speed-control loop, and no re-adjustment of control-loop gain will be required.

The regulator will maintain the ability to regulate the gas flow independently of upstream or downstream pressure variations to the degree shown by the steady-state data up to the break frequency of 6 cycles per second. Above this frequency gas-flow variations will increase at approximately 6 decibels per octave with frequency of inlet or outlet pressure perturbations.

Performance in Engine-Speed Loop

In the discussion of the transient response it is noted that the regulator was of the order of 100 times faster than the engine. The dynamics of the regulator would therefore not affect the control-loop response. Calculations for the manifold response indicated that its time constant was of the order of 1/2 second at the rated flow condition. This makes the manifold response of the order of 5 to 10 times the response of the engine, and, hence, the control loop will not be affected to any great extent.

Figure 7 is a plot of JP-4 fuel flow to the ratio regulator, engine speed, compressor discharge pressure, and pressure drop across the manifold as a function of time during which the JP-4 fuel flow to the ratio regulator was subjected to a transient. The resulting damped oscillation in all the variables indicates the action of the regular engine control in recovering from the disturbance. None of the variables indicates any unstable tendencies. The response shown in figure 7 is quite similar to the response obtained with the normal configuration of the control system using JP-4 as the engine fuel, which indicates that the dynamic response of the elements added to the control loop when operating on hydrogen is sufficiently high that the control-loop dynamics are not affected. The responses of the control system to throttle bursts conducted during flight tests were similarly well behaved.

CONCLUDING REMARKS

The fuel tank used in this investigation was designed for relatively low pressures, and thus the total pressure drop available from the supply tank to the engine combustion chamber was relatively small. This

low-resistance-type system has poor flow regulation, that is, small changes in supply-tank pressure or combustion-chamber pressure can cause large changes in flow. In addition, variations within the system, such as the vaporizer acting like a pressure generator, can disturb the flow. A flow regulator tends to stabilize these flow instabilities by introducing a variable resistance in the system. The exact nature of these instabilities and the contribution of the dynamics of each of the components of the fuel system and the engine to them have not been determined. It is probable that configurations of this engine and fuel system could exist which could not be stabilized by flow regulators. This instability is one of the major problems of a low-resistance-type hydrogen fuel system incorporating a vaporizer.

The successful performance of the ratio regulator both in the ground tests and in flight indicates that the principle of controlling the second fuel of a dual fuel system from the primary fuel control is practical. Such a system is especially attractive if one of the fuels has properties that make it difficult to handle because mechanical contact with the "unfriendly" fluid is minimized. Although the experimental investigation was limited to a very narrow flight range, primarily because of a supply-tank pressure limitation, the hydrogen control unit can handle a much wider range of flows by maintaining the supply pressure somewhat above the injection manifold pressure.

Lewis Flight Propulsion Laboratory
National Advisory Committee for Aeronautics
Cleveland, Ohio, July 16, 1957

REFERENCES

1. Silverstein, Abe, and Hall, Eldon W.: Liquid Hydrogen as a Jet Fuel for High-Altitude Aircraft. NACA RM E55C28a, 1955.
2. Corrington, Lester C., Thornbury, Kenneth L., and Hennings, Glen: Some Design and Operational Considerations of a Liquid-Hydrogen Fuel and Heat-Sink System for Turbojet Engine Tests. NACA RM E56J18a, 1956.
3. Braithwaite, Willis M., Fenn, David B., and Algranti, Joseph S.: Altitude-Chamber Evaluation of an Aircraft Liquid-Hydrogen Fuel System Used with a Turbojet Engine. NACA RM E57F13a, 1957.
4. Mulholland, Donald R., Acker, Loren W., Christenson, Harold H., and Gough, William V.: Flight Investigation of a Liquid-Hydrogen Fuel System. NACA RM E57F19a, 1957.

5. Fenn, David B., Braithwaite, Willis M., and Ordin, Paul: Design and Performance of Flight-Type Liquid-Hydrogen Heat Exchanger. NACA RM E57F14, 1957. C
6. Jonash, Edmund R., Smith, Arthur L., and Hlavin, Vincent F.: Low-Pressure Performance of a Tubular Combustor with Gaseous Hydrogen. NACA RM E54L30a, 1955.

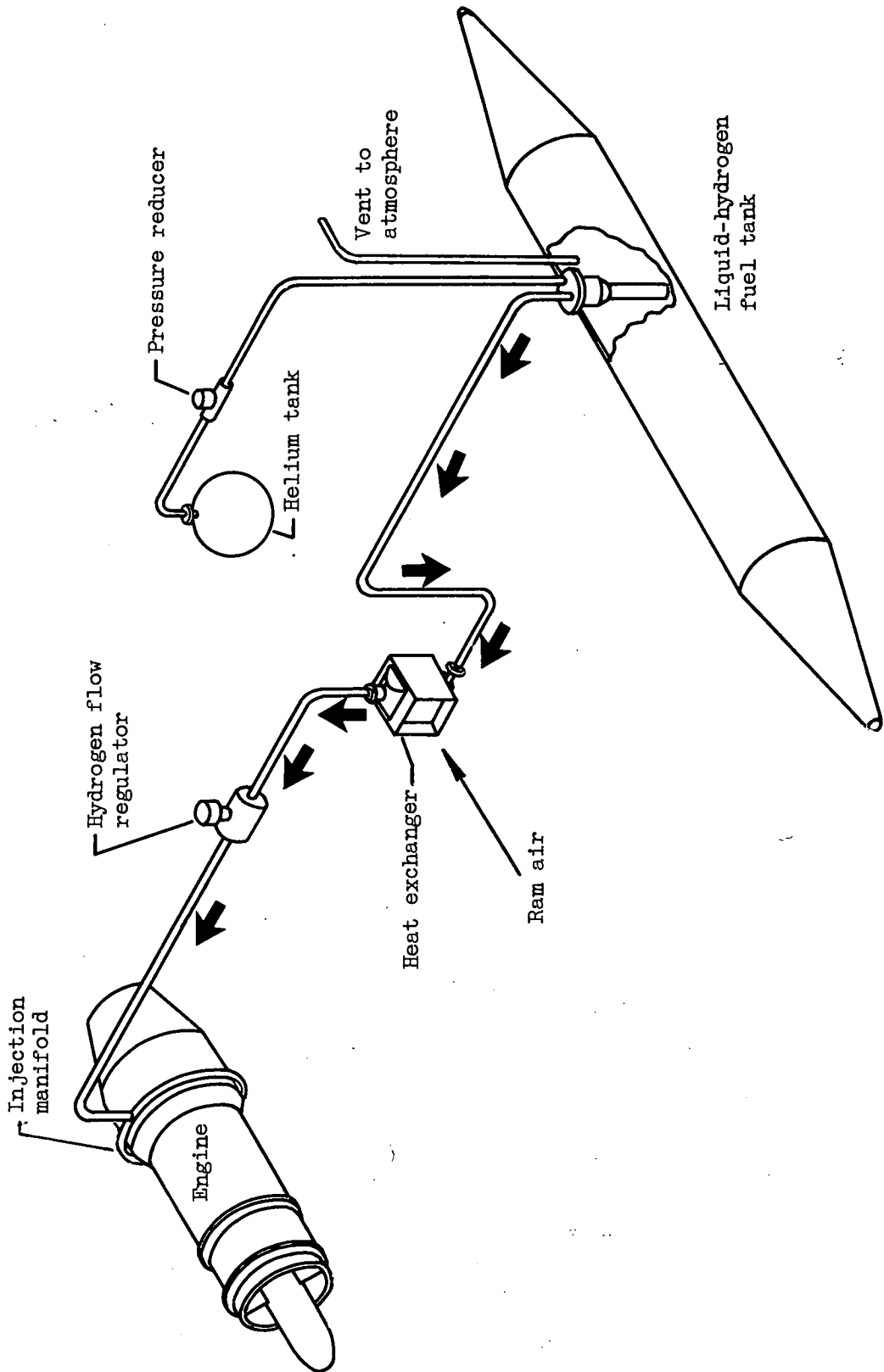

CS-13679

(a) Schematic drawing of components.
Figure 1. - Hydrogen fuel system.

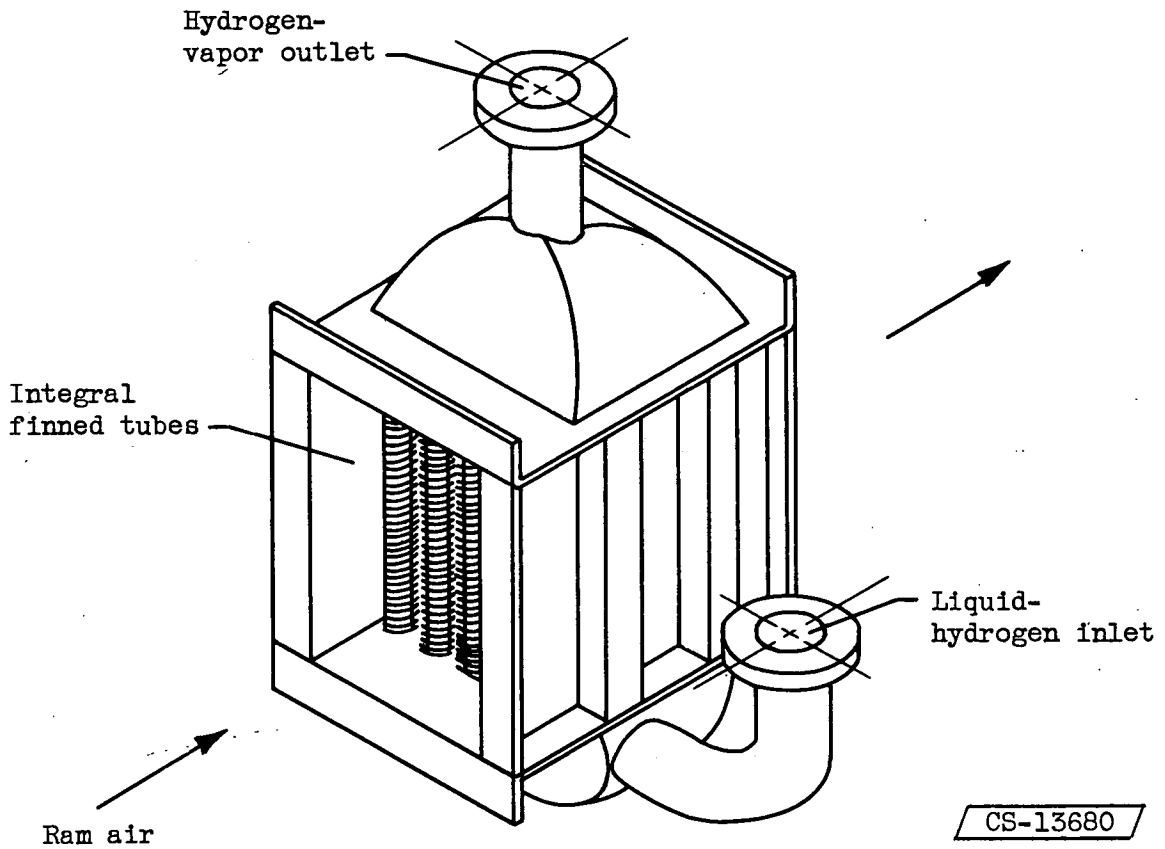

(b) Diagram of heat exchanger.

Figure 1. - Continued. Hydrogen fuel system.

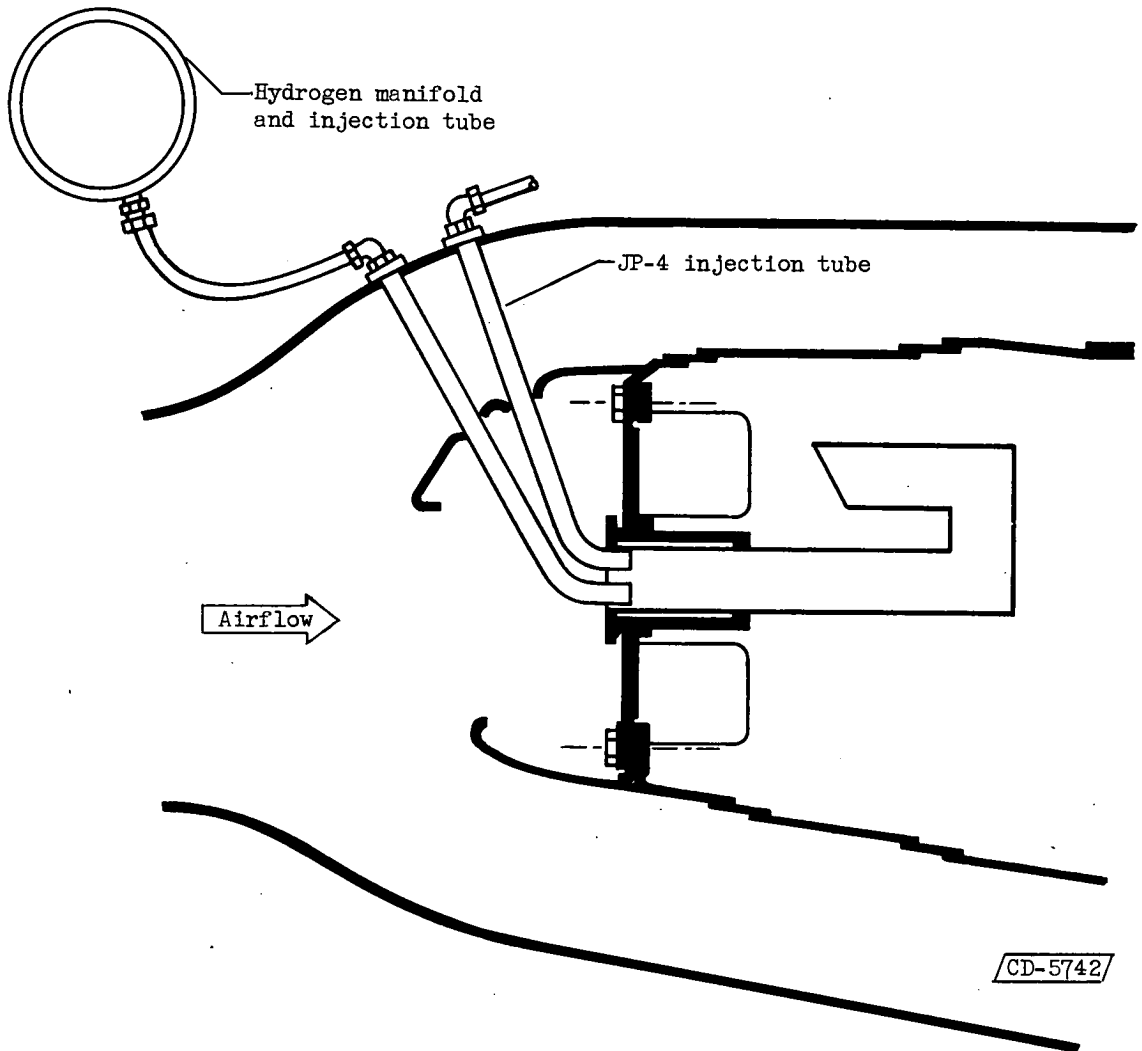

(c) Method of injecting hydrogen gas.

Figure 1. - Concluded. Hydrogen fuel system.

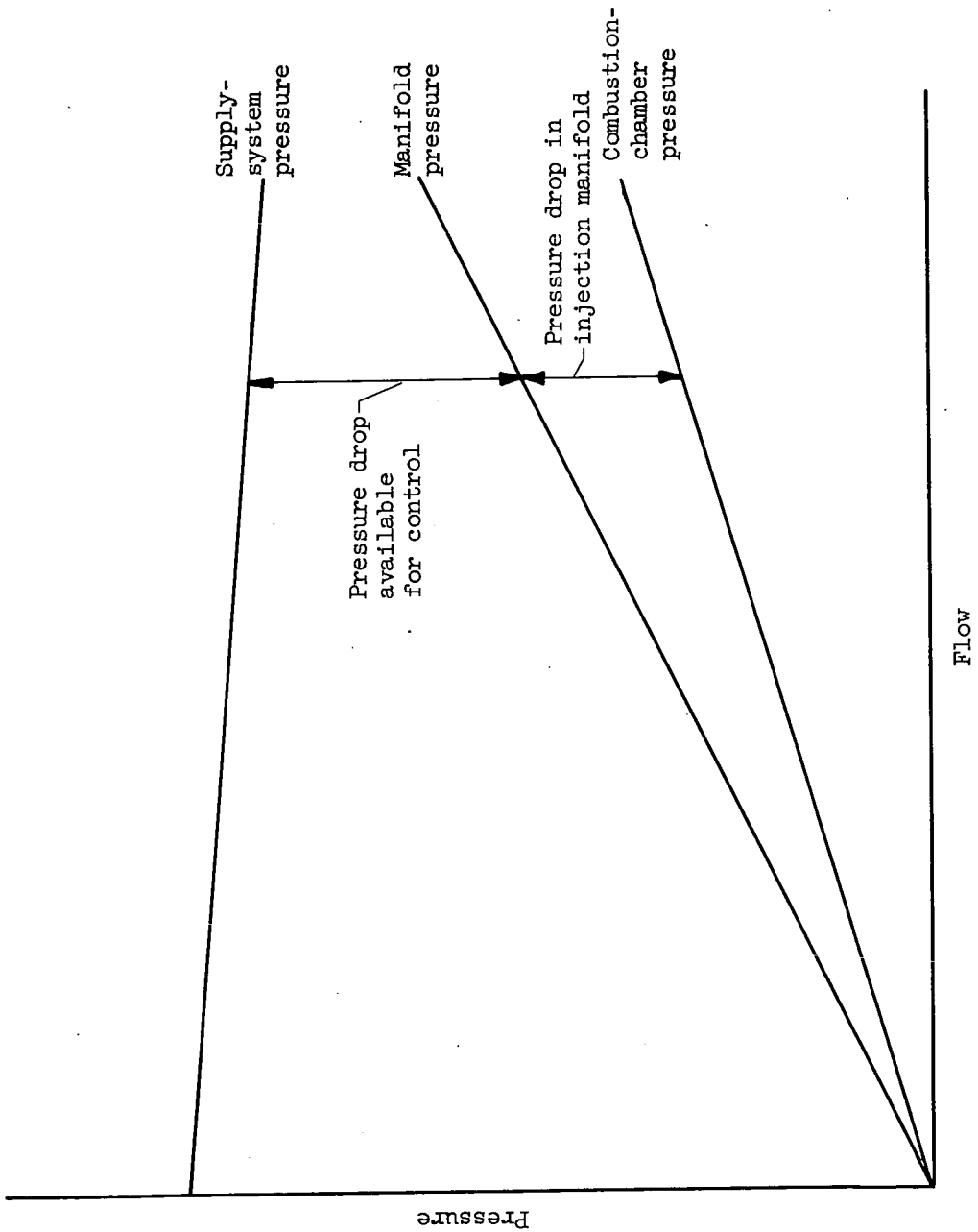
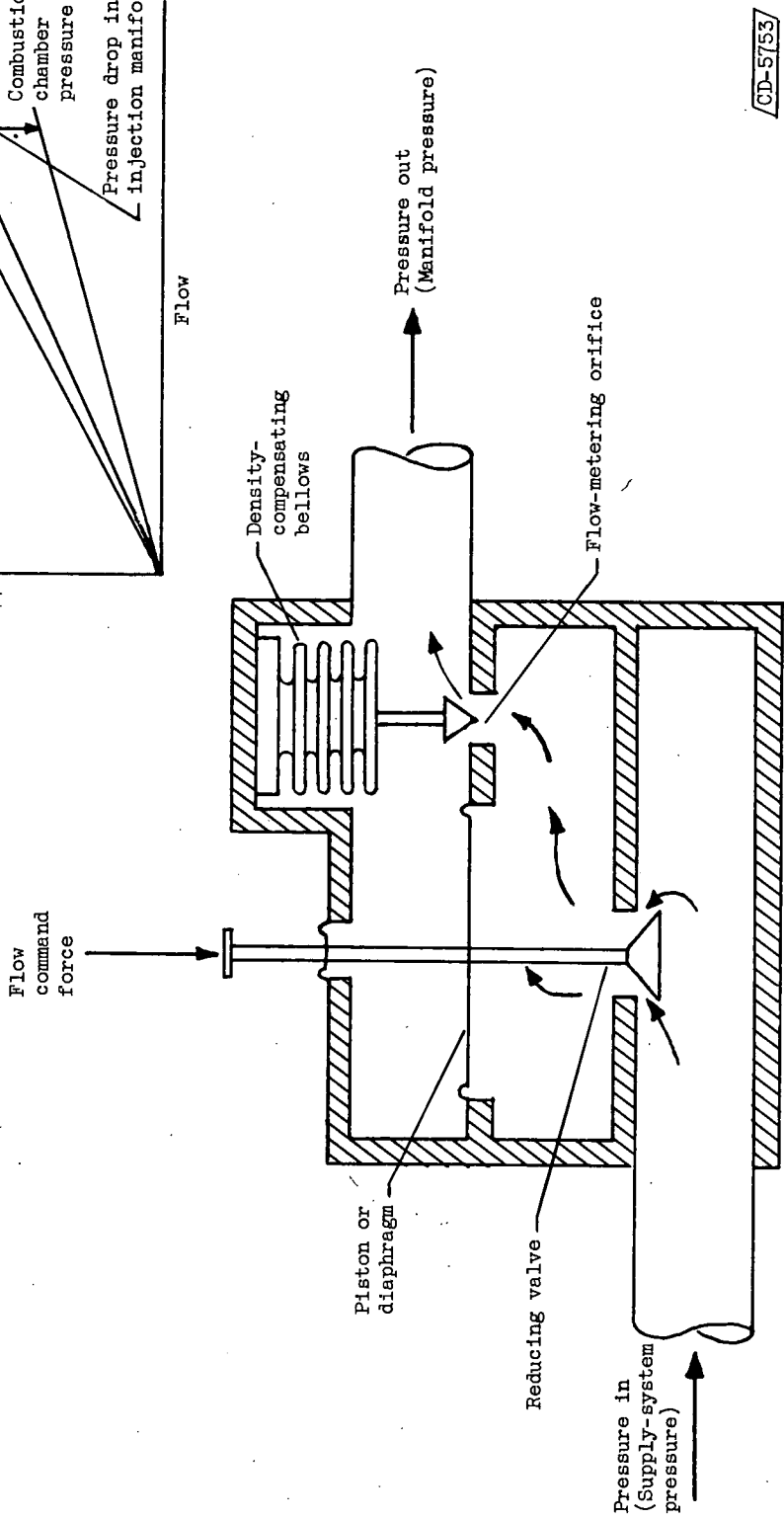
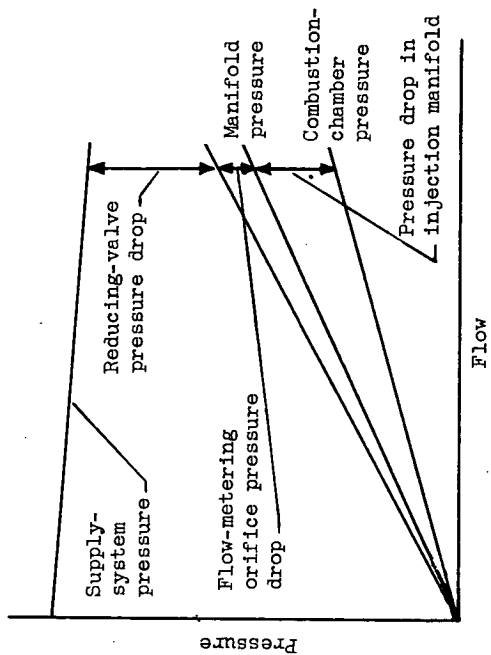
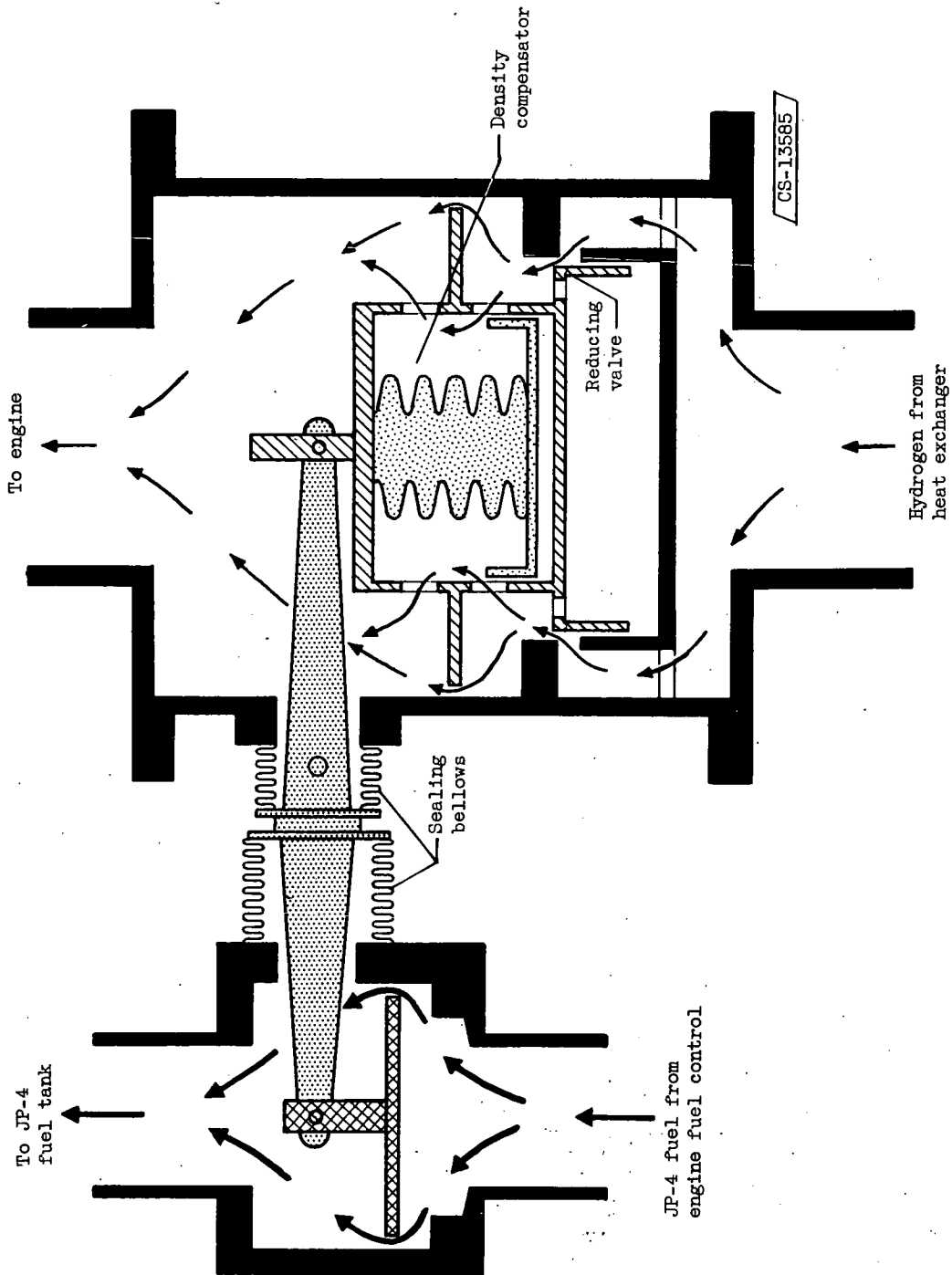

Figure 2. - Pressure-flow characteristics of hydrogen fuel system.



CD-5753

Figure 3. - Schematic diagram of differential-reducing-valve flow regulator used for hydrogen-fuel-system flow control.



(a) Schematic drawing.

Figure 4. - JP-4 hydrogen ratio regulator.

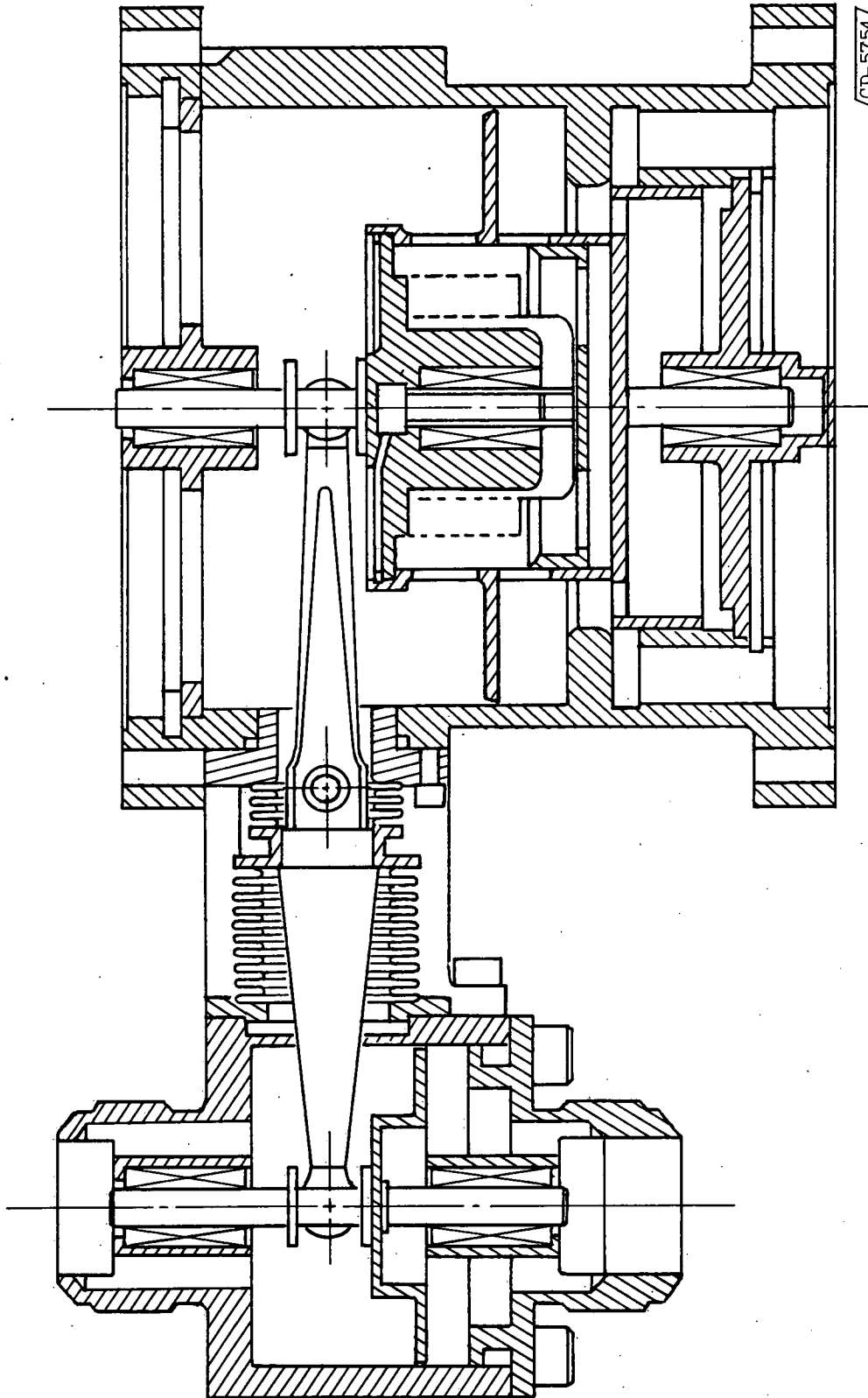

CD-5754

(b) Cross-sectional drawing.

Figure 4. - Concluded. JP-4 hydrogen ratio regulator.

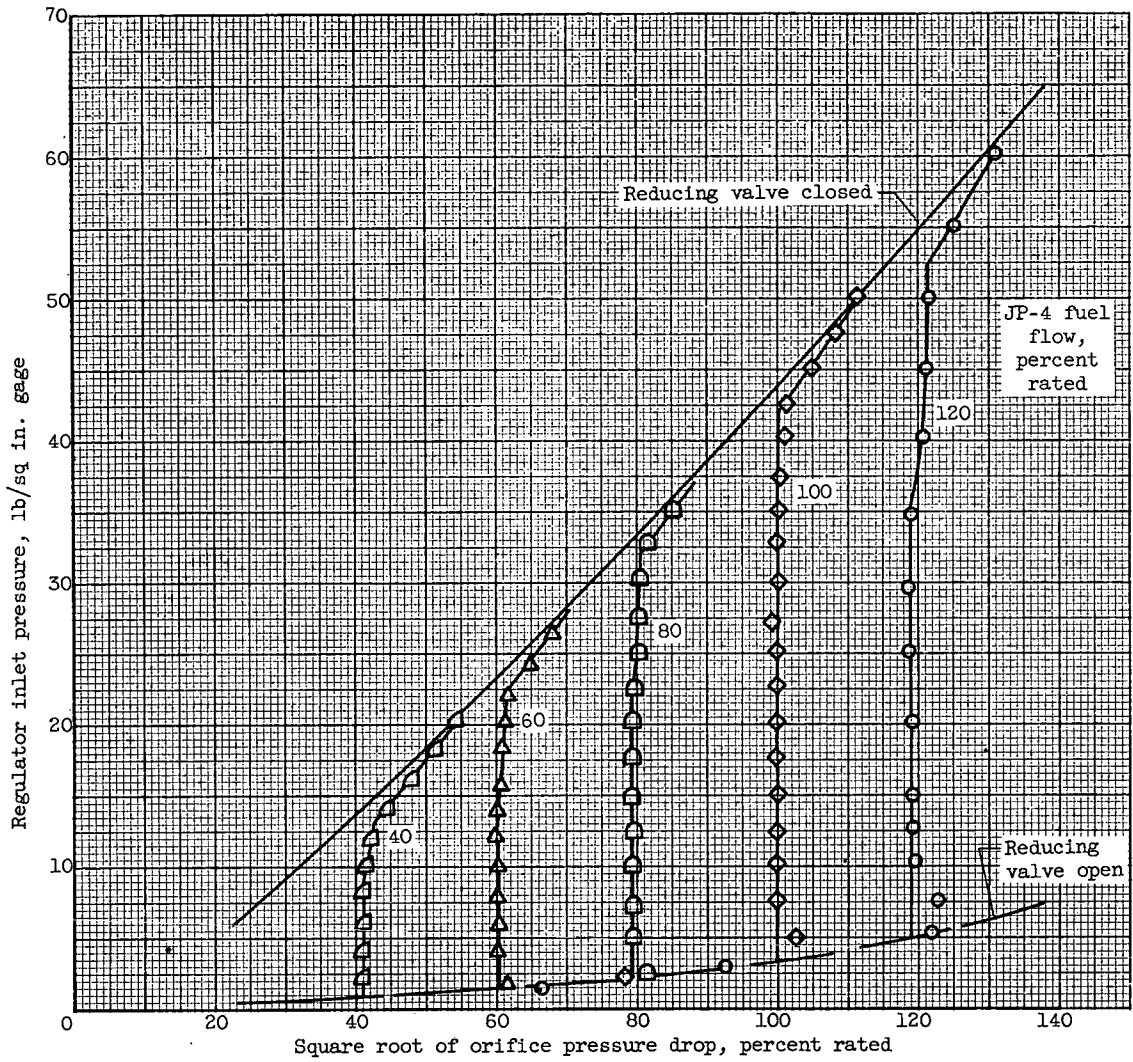

(a) Inlet-pressure variation. Discharge pressure, 1 atmosphere.

Figure 5. - Insensitivity of regulator to pressure variations.

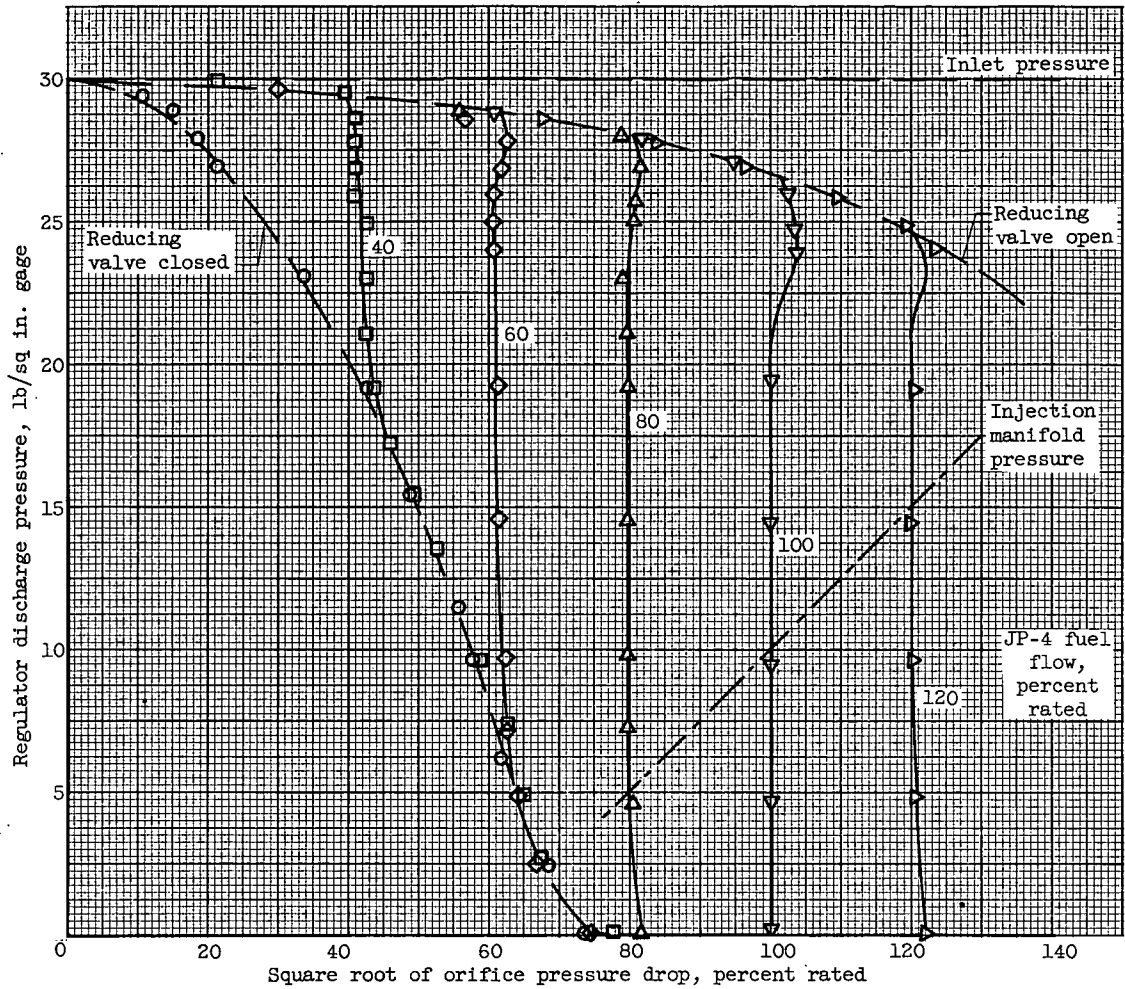

(b) Discharge-pressure variation. Inlet pressure, 30 pounds per square inch gage.

Figure 5. - Concluded. Insensitivity of regulator to pressure variations.

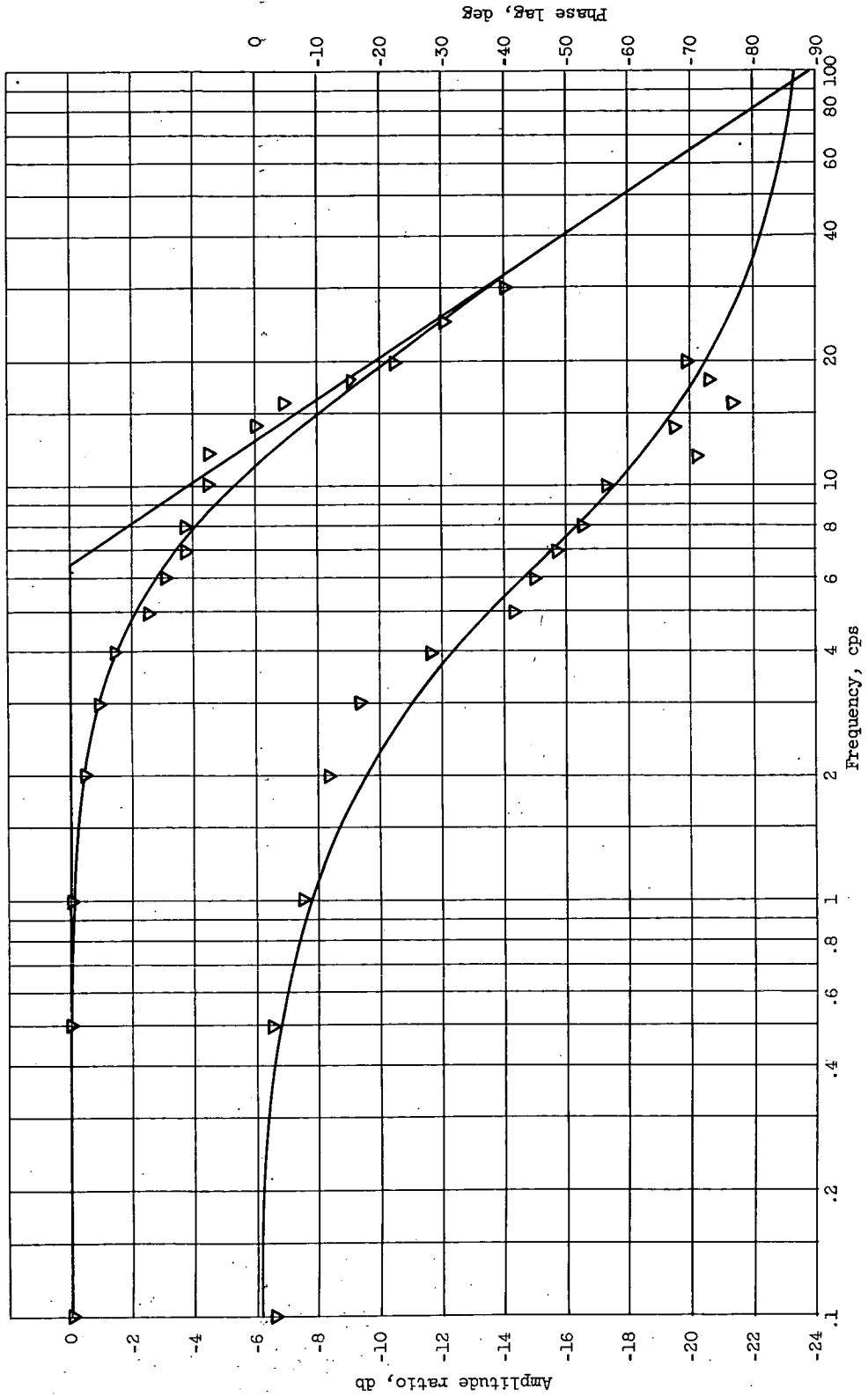

Figure 6. - Response of gas flow to liquid flow. Perturbation amplitude, ± 10 percent of rated JP-4 fuel flow.

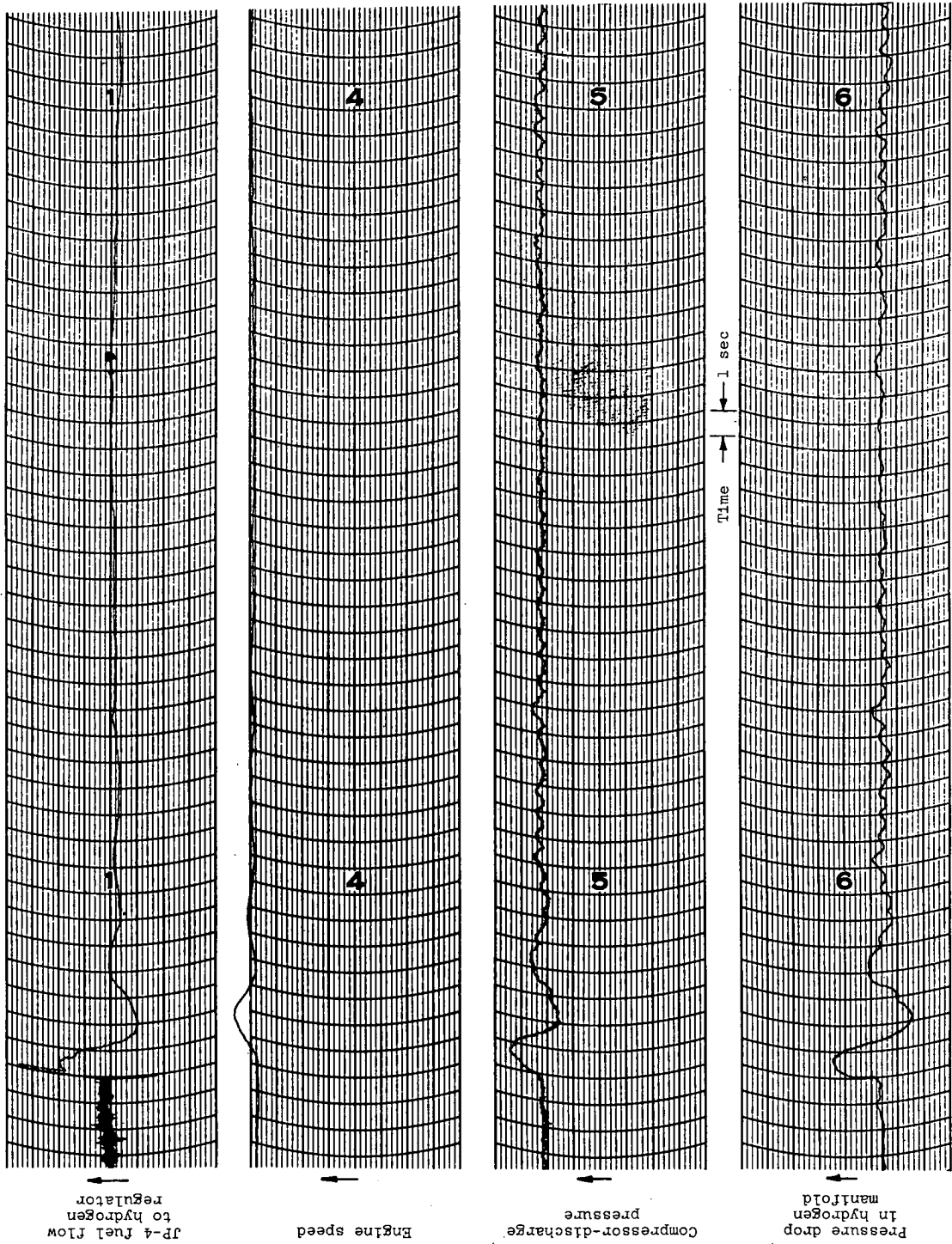

Figure 7. - Response of engine variables to disturbance in JP-4 fuel flow to hydrogen regulator.