

## Claremont Colleges Scholarship @ Claremont

---

CMC Senior Theses

CMC Student Scholarship

---

2011

# The Importance of Leadership and Culture in Mergers

Aravind Swaminathan  
*Claremont McKenna College*

---

### Recommended Citation

Swaminathan, Aravind, "The Importance of Leadership and Culture in Mergers" (2011). *CMC Senior Theses*. Paper 260.  
[http://scholarship.claremont.edu/cmc\\_theses/260](http://scholarship.claremont.edu/cmc_theses/260)

This Open Access Senior Thesis is brought to you by Scholarship@Claremont. It has been accepted for inclusion in this collection by an authorized administrator. For more information, please contact [scholarship@cuc.claremont.edu](mailto:scholarship@cuc.claremont.edu).

**CLAREMONT McKENNA COLLEGE**  
**THE IMPORTANCE OF LEADERSHIP AND CULTURE IN MERGERS**

SUBMITTED TO  
PROFESSOR RONALD RIGGIO  
AND  
DEAN GREGORY HESS  
BY  
ARAVIND SWAMINATHAN

FOR  
SENIOR THESIS  
FALL 2011  
NOVEMBER 28, 2011



**Table of Contents**

ACKNOWLEDGEMENTS.....	4
ABSTRACT.....	5
INTRODUCTION.....	6
OBJECTIVES.....	9
CHANGE.....	10
CHANGE IN AN ORGANIZATIONAL CONTEXT.....	11
MERGERS: BUSINESS STRATEGY.....	15
LEADERSHIP.....	20
CULTURE.....	23
EFFECTIVENESS AND STRATEGY.....	29
ANALYZING CULTURES.....	46
AN APPLICATION OF STRATEGY.....	54
CONCLUSION.....	56

### **Acknowledgements**

I would like to thank Professor Ron Riggio for all his guidance, support, and inspiration in the writing of this thesis. Taking Organizational Psychology with Professor Riggio my freshman year is what sparked my interest in organizational behavior, workplace psychology, and organizational analysis. Professor Riggio helped me discover my passion and interests and I want to thank Professor Riggio for helping me find the inspiration for this thesis. Without his leadership, this thesis would not be possible. I would also like to thank the Claremont McKenna's Psychology Department for helping me hone my critical thinking and analytical skills, as well as instilling a constant sense of curiosity in me.

**Abstract**

*The purpose of this paper is to show how leadership and culture are critical factors in organizational change. The vehicle through which this point is proved is by analyzing the organizational change processes of mergers, as mergers involve leadership and culture. Successful mergers are very rare, and it is hypothesized that not enough attention is paid to leadership and culture during mergers. This paper analyzes many of the factors that related to leadership and culture, such as transparency, trust, communication, and vision. Not only does this paper analyze these topics, but it also examines and applies a successful change strategy, tailored for mergers.*

## The Importance of Leadership and Culture in Mergers

### I. Introduction

In 1998, two of the world's most prominent automobile manufacturers Daimler-Benz and Chrysler Corporation announced the two companies were to merge (Daimler, Chrysler and the Failed Merger – Management Case Study). The merger created the DaimlerChrysler entity and became the world's third largest automobile company based on revenues, market capitalization, and earnings (Daimler-Chrysler Merger: A Cultural Mismatch?). The Chairman of Daimler-Benz at the time was Juergen Schrempp and he publicized the merger was a "merger of equals". Daimler-Benz was a German based company and Chrysler Corporation was a United States based company, and the merging of the two companies hoped to create a mutual advantage of entering each others' markets. Chrysler hoped to enter the European market and Daimler-Benz sought to infuse its luxury brand further within the United States. The deal at the time seemed to make perfect sense. As time went on though the DaimlerChrysler merger has been named one of the biggest merger failures of all time after Daimler eventually sold all its shares of Chrysler Corporation to another party.

Why did the DaimlerChrysler merger fail? At the time, many analysts believed the merger would be highly successful—a move that would dominate the automobile world. On the other hand, there were many skeptics who believed the deal was destined to turn into a failure. In hindsight, an analysis of the merger shows that the deal had two

severe problems: a leadership dilemma and the lack of a cultural fit. According to Michelle Krebs,

“the marriage was doomed to fail because it was built on sand, not on a solid rock foundation. It missed a basic building block from the start: honesty. From the start, the leaders of the two companies billed the so-called marriage as a merger of equals. That was a scam. Chrysler was bough and was subsequently treated like a stepchild, not a partner. The domination by one partner over the other filtered down through the rank and file” (Daimler-Chrysler: Why the Marriage Failed – AutoObserver).

The lack of transparency and honesty between the leadership that influenced the deal coupled with an apparent lack of vision and leadership ability turned the acquisition into a failure (Daimler-Chrysler: Why the Marriage Failed – AutoObserver).

Another issue was the culture of the two merging companies. Though initially the two distinct companies were thought to be perfect complements, the major differences in the companies proved that there was an inherent compatibility problem that was unable to be changed. For example, “Decision making at Daimler-Benz (influenced by German culture)...was approached very methodical; at Chrysler on the other hand, creativity in the decision making process was asked for and strongly encouraged (Hollmann). Among Chrysler’s values you find efficiency, empowerment of the employees and equal rights among all staff; Daimler-Benz culture is more based on authority, bureaucracy and centralized decision making” (Hollmann).

Though the two companies tried to unite to turn strengths into weaknesses, they proved that leadership and cultural are essential to a successful merger. One wonders if the leaders of the two companies were more transparent and honest in their respective



visions if the merger would have been more successful. Another question is whether the leadership of Daimler-Benz and Chrysler Corporation adequately examined the possibility of uniting two very different cultures.

A similar situation to the DaimlerChrysler merger shows how a merger can be successful. In 1999 Renault-Nissan was formed through uniting Renault Samsung Motors and Nissan Motor Company and in 2003 it was one of the world's top five automakers (Stahl, 4). A conversation with Carlos Ghosn, who was president and CEO of Nissan and became President and CEO of Renault—the majority owner of the merger—shows how effective leadership and an analysis of culture led to the success of the deal in 1999. Ghosn highlights the importance of analyzing the people aspect of mergers instead of just a financial perspective, which is demonstrated by the DaimlerChrysler deal (Stahl, 4). Ghosn describes how his leadership was crucial to the success of the integration of two cultures; he states, “My experience with Nissan has reconfirmed my conviction that the dignity of people must be respected even as you challenge them to overturn deep-stead practices and traditions...The most fundamental challenge of any alliance or merger is cultural” (Stahl, 4). Ghosn shows that his focus as a leader of the merger is to respect the individuals of the two companies to unite them into one company, instead of solely focusing on profits and revenues from a financial standpoint. Ghosn's commitment to exemplary leadership and focus on culture illustrates why the Renault-Nissan merger is successful today.

Another leader of the product of a merger, CEO of GlaxoSmithKline Jean-Pierre Garnier states his view on mergers and acquisitions, “In any merger or acquisition, investment banks and equity analysts will provide you with a plethora of figures quantifying the synergistic strategic benefits of the union. Yet what determines whether a merger succeeds or fails is really its people” (Stahl, 4). The purpose of this paper is to analyze how leadership and culture influence mergers and acquisitions through change management. As Garnier believes mergers and acquisitions are about “people,” this paper seeks to show how effective leadership and an analysis of culture create success in a business deal. Leadership and culture are two central issues in the “people” side of business and in today’s ever changing business world, it is important to analyze how these two issues are key to a merger and acquisitions success.

## **II. Objectives**

This paper has a number of objectives. The main objective is to show how leadership and culture are important factors in organizational change. The vehicle through which this claim is supported is “mergers”. Mergers were selected as this business strategy is a very common business move today that creates a great deal of organizational change and is often not successful. Mergers require the focus of leadership and culture—as this paper will show—and they help support the notion that leadership and culture need to be more stressed in organizational change.

The paper begins by examining change. Change is defined and shown to be very important as it involves “people”. Next, mergers, leadership, and culture are defined. Understanding what mergers, leadership, and culture are is critical to understanding how

the three concepts work together and in order to build and understand effective change strategies. Leadership and culture are very closely linked to change, and understanding how the leadership and culture are intertwined help accomplish the paper's objective; the culture section focuses heavily on Edgar Schein's literature, as it shows how leadership, culture, and change are highly related. Important factors, related to leadership and culture, such as vision, communication, trust, transparency, and internal analysis are also examined in this paper. The analysis of these many factors in conjunction to leadership and culture shows how complex change can be.

The paper then moves to understanding effective change strategies and applying strategies in merger contexts. This paper analyzes and applies change strategies put forth by leaders in the field. The paper also suggests how to analyze culture, through a change perspective in the face of a possible merger. The paper ends with recommendations and an application of strategy for the DaimlerChrysler merger.

### **III. Change**

Why is it important to analyze the importance of leadership and culture within mergers? The answer is because leadership, culture, and mergers have to deal with "change"—something that is very important to individuals and organizations today. At a basic level, the Merriam-Webster Dictionary defines change as:

- a. To make different in some particular.
- b. To make radically different.
- c. To give a different position, course, or direction to" ("Change.").

Change is a part of life today and will always be important. Reading literature from *The Wall Street Journal* to *The New York Times* features stories of companies that must face

and cope with organizational change today. When a company must deal with organizational change, all levels of employees—from the CEO to the everyday staff—must deal with change. Because change is an integral part of life and an organization's life today, it is important to understand what factors can influence and help cope with change, as change can be a “frightening” experience.

The difficulties implementing change were recognized by Niccolo Machiavelli in

*The Prince*:

“...there is no more delicate matter to take in hand, nor more dangerous to conduct, nor more doubtful in its success, than to set up as the leader in the introduction of changes. For he who innovates will have for his enemies all those who are well off under the existing order of things, and only lukewarm supporters in those who might be better off under the new” (Machiavelli, 12).

Machiavelli identifies how hard—and almost dangerous—it can be for a leader to implement change. Even though Machiavelli presents the difficulty and risk in implementing change within an organization, it is important to realize that change can be extremely beneficial within an organization (Gill, 307). This paper focuses on analyzing how the factors of culture and leadership can be instrumental in implementing successful organizational change, specifically within mergers.

#### **IV. Change in an Organizational Context**

Companies throughout the world must deal with the effects of change in today's rapidly and continuously changing world. But what causes the need for change for a company? Why question the old saying, “if it isn't broke, why fix it?”. The most successful companies of the world are successful because they see the need to adapt and

embrace change. If companies did not see the need to adapt, companies would still be hand painting toys and using horses to deliver. A company needs to reflect internally and externally in deciding that it needs to implement change within itself (Nilakant, 32). V.

Nilakant and S. Ramnaryan write in *Change Management* about the “experiential learning model”:

“First, it suggests that organisations are purposive, goal-oriented systems. They set themselves targets or goals, which represent the organisation’s aspirations about its performance, Performance for an organisation could be sales, profitability, market share, return on investment and so on. In other words, organisations aspire to a certain level of sales, profitability, market share, and return on investment...

Second, if the performance exceeds their aspirations, they consider themselves to be successful. However, if performance falls below targets or aspiration levels, they see themselves as having failed. Perceptions of failure lead to change. Organisations institute a process of search to determine causes of failure and take corrective actions.... (Nilakant, 32)”

Nilakant and Ramnaryan describe the main reasons why organizations feel the need to change. Organizations are goal oriented and define success through achievements and performance (Nilakant, 32). When an organization does not perform at its desired level, it seeks ways to improve and raise performance—through organizational change.

A company needs to analyze internal and external factors in order to decide whether it needs to implement organizational change (Nilakant, 34). Today’s global landscape of business makes it important to analyze the external factors of global competitors and global trends along with new, more efficient technology, and public policy (Hambrick, 5; Nilakant, 70). Nilakant and Ramnaryan believe change can be viewed as a response to external factors found in the environment—factors such as

customers, competitors, suppliers, and government agencies (Nilakant, 57). Nilakant and Ramnarayan also describe how organizations must take into account the societies and cultures they exist within and understand habits, customs, and tastes (Nilakant, 57). The environment that houses external factors influencing an organization is a very complex concept with many different parts that a business can be affected by and must monitor to know when it must implement organizational change (Nilakant, 57). As mentioned earlier, an organization is goal driven and a failure to meet expectations and perform can promote the need for change.

A company can also measure performance through analyzing its internal factors. A company can perform a “Change Need Analysis” described by Nilakant and Ramnarayan—an analysis that takes into account factors such as profitability, growth, employee satisfaction, financial ratios, public image of the company, adaptability, efficiency, innovation, and social impact—which are all factors that can help indicate how well a company is performing (Nilakant, 34). Nilakant and Ramnarayan believe these factors are encapsulated by the four larger levels of “technology, quality, costs, and marketing”—levels they call the “four content levelers of change” that establish internal factors that can be analyzed (Nilakant, 36). A company must analyze how well these four levels are performing and progressing in order to meet performance expectations and goals. Another way to monitor internal performance of a company is to embrace innovation and strive to solve any organizational problems as well. Embracing innovation

and solving problems can create the need for change and help exceed performance expectations.

What does organizational change look like for employees though? It is clear companies must monitor external and internal factors, but it can be hard to understand after determining the need for organizational change what it means to implement change within the company on an individual basis. To Nilakant and Ramnaryan it is all about changing routines within an organization. They believe the following tenets of change management:

- “...Organisations are maintained in the status quo by their routines.
- Organisational change involves changing routines in an organisation that maintain stability.
- These routines are embedded in people’s head (sic) as mindsets or mental models These mindsets or mental models are made up of assumptions, values and beliefs. More importantly, they contain formulae or codes to guide behavior in specific situations.
- Since routines create and sustain stability in an organization, change management is largely about changing people’s mindsets...
- Change management requires engagement and connection with those whose mental models need to change
- Dialogue and conversations constitute the medium of change” (Nilakant, 29).

Ramnaryan and Nilakant describe their model of change management quite clearly: it is about changing the routine and mindsets of individuals through effective communication.

Change management can affect employees at all levels of the organization—the key is identifying which employees need to embrace change and change their routines and mindsets and effectively doing so. Nilakant and Ramnarayan’s tenets of change

management are highly related to leadership and culture within an organization and will be discussed throughout this paper. Researchers John W. Moran and Baird K. Brightman agree with Nilakant and Ramnaryan's tenets and build upon their idea. They write, "Managing change is about managing people...Managing change draws on our knowledge of human motivation, groups and leadership" (Moran, 66).

### **V. Mergers: Business Strategy**

It is clear that organizations today must pay attention to internal factors and external factors that can heavily influence organizational performance. If a company wants to improve its position within its industry it must pay attention to trends and technology as well as competitors. The necessity to pay attention to many factors can be an overwhelming task for many CEOs and company presidents. Some organizational leaders can even be overwhelmed by this "daunting task" of staying aware and consequently lead their businesses to become stagnant—not embracing innovation or seeking to improve organizational processes. When companies do not perform as desired, many turn to the business strategy of performing a "merger". Mergers are used commonly with the practice of "acquisitions," but the two are very different. According to *Investopedia*, mergers are when two companies—similar in size—decide to come together to form one, new company that works together ("Mergers and Acquisitions: Definition"). Mergers are different than acquisitions in that acquisitions occur when a company takes over another company and establishes it is the new, clear owner of the targeted-company that was acquired ("Mergers and Acquisitions: Definition"). The



practice of mergers and acquisitions has become very popular in recent years; Mark Clemente writes, “Mergers and acquisitions (M&A—a key corporate growth approach—has graduated from an occasional shot in the dark to a well-established option in an operating company’s basket of corporate development initiatives” (Clemente, ix). Mergers can be seen as a chance for two companies to work together and come together to combine efficiencies and practice to create one, very strong company. Acquisitions are seen to be more of a dominating move by a company to take advantage of specific efficiencies, often times patents or technology. In acquisitions, cultures are frequently replaced and leadership becomes dominated. This paper focuses on the intricacies of leadership and culture within a merger, as companies must work together to analyze leadership and culture during mergers whereas in acquisitions less emphasis is placed on leadership and culture.

Mergers have been increasingly popular in the recent years and require a great deal of research, diligence, and analysis—but the question is why have famous mergers failed and are the proper factors being analyzed? Clemente writes,

“Several factors are fueling the continuing explosion in merger activity. The ability of businesses to successfully achieve economies of scale, broaden geographic market coverage, and more effectively compete globally have helped create an aggressive acquisition marketplace. In addition, the search for cost reductions through M&A...is being used to offset companies’ inability to increase profits through price or production increases. In all likelihood, the merger mania of the late 1990s will carry over into the new millennium as these and other factors drive corporate growth planning” (Clemente, 1).

This passage shows the aspect of companies seeking to increase financial performance through mergers. Mergers allow companies to increase performance by combining

companies and enjoying new opportunities that would otherwise be impossible. For example, as suggested by Clemente, a company that cannot reduce costs can increase its performance by merging with another company by increasing production and volume and attracting new customers. Most of the analysis in whether a merger will be successful is through financial ratios and analysis. Analysts study marketing investment ratios, productivity ratios, efficiency ratios, valuation of tangibles and intangibles, discounted cash flows, comparable transactions, comparable companies, and liquidation analyses—at the end of the day, the deal must be profitable for both companies (Clemente, x).

Though most of the analysis is quantitative, qualitative aspects are analyzed to, but in a manner that is to put a quantitative “tag” to these qualitative aspects. These aspects include trying to analyze strength of marketing staff, sales force, customer base, distributors, and cultural marketing orientation; the goal of analysts is to value of how strong these intangibles are and whether merging can leverage the value, or potential value, of these intangibles (Clemente, 7). Clemente summarizes three areas that are scrutinized in a possible merger: “people, products, and processes” (Clemente, 19).

Products and processes are the core of a business’s service or mission and are at the heart of strategy and operations. Analysts must value how strong a company’s products and processes are in order to determine the overall strength of a company as well. But evaluating people is much more difficult than evaluation products and processes—it is much harder to put a dollar figure to the strength of people, as people are unique and are hard to compare. This is an area where mergers need to pay attention to—the people.

Gunter Stahl writes, “In mergers in acquisitions (M&A) special emphasis is usually placed on the strategic and financial goals of the deal, while the psychological, cultural, and human resource implications do not receive as much attention” (Stahl, 5). The people side of the business strategy of mergers does not get enough consideration in many of these deals—which is why many mergers often lead to failure. David Fubini, Colin Price, and Maurizio Zollo begin their book with the title, “The Elusive Healthy Merger”. They state, “Academic researchers and consultants have consistently shown that on average mergers and acquisitions deliver at best mediocre performance outcomes. The typical merger is therefore a bet against the odds” (Fubini, 1). Many of the world’s most famous companies have witnessed great failure in the hopes of merging with another company. Some of these companies, along with Daimler-Benz and Chrysler, according to CNBC include the New York Central and Pennsylvania Railroads, Mattel and the Learning Company, Sears and Kmart, Sprint and Nextel, AOL and Time Warner, and Quaker and Snapple (“News Headlines”). These companies that failed to unite were some of the most successful companies and were extremely famous—unfortunately merging was not the answer for these companies. Other successful companies did not find success in mergers, when they sought to merge with the idea that “bigger is better” (Clemente, 35). These companies who wanted to combine with other large companies to dominate their industries include Time Inc. and Warner Communications Inc. and Nabisco with R.J. Reynolds (Clemente, 35). The merging of these four companies into two larger companies have earned the title of “megamergers” due to their size (Clemente,

35). According to Clemente, RJR Nabisco was not successful because it “has never been able to integrate the products, markets, or cultures of these two diverse companies” (Clemente, 35). Similarly Time Inc. and Warner Communications, which was formed in order to dominate the media and communication industry, is not successful due to, “the lack of a unified synergistic culture” (Clemente, 35). But interestingly, other companies have enjoyed success through the merger strategy, as illustrated by Renault-Nissan. CNBC hails the Disney-Pixar, Sirius-XM Radio, and Exxon-Mobil mergers to be some of the best mergers of all time (“News Headlines”). Why have these famous companies witnessed success in merging with other companies when so many others have failed? Is there something different in the leadership of these companies and the culture of these companies?

Fubini, Price, and Zollo highlight the importance of leadership and culture in *Mergers: Leadership, Performance, and Corporate Health*. The researchers believe not enough importance is placed on leadership and culture, specifically within mergers and this is why many mergers fail (Fubini, 5). The researchers believe that leadership has an “underdefined” role within mergers because many top leaders do not know how to add real value (Fubini, 6). This is a large problem if the leader or leaders of a merging company do not know how to add value—as this can result in the failure of a merger. Fubini, Price, and Zollo also state, “Cultural integration is the most vexed topic in the field. Here there is practically no consensus around what best practice is” (Fubini, 37). The researchers suggest one of the problems with culture in mergers is there is no one-

best theory in how to integrate cultures of organizations, because often times mergers witness the “dominance” or “championing” of one culture over another—which creates an acquisition like scenario. More focus needs to be placed on leadership and culture, especially as this paper will suggest how important the two are together. Leadership and culture are highly related and before this paper can examine how the two can be combined to achieve merger success, it is very important to understand what leadership and culture mean in a merger context.

## **VI. Leadership**

Leadership can be difficult to define or conceptualize, but it is very important to understand its definition—especially how it is important in an organizational context. The facts that leadership is not tangible and can possess many different connotations make leadership hard to define. Leadership has been studied for thousands of years in very many contexts, but Peter G. Northouse in *Leadership: Theory and Practice* has helped define leadership in a thorough manner: “Leadership is a process whereby an individual influences a group of individuals to achieve a common goal” (Northouse, 2). Northouse breaks down leadership into three key parts which include *influence*, *groups*, and *common goal* (Northouse, 3). Influence is especially important as a leader must be able to influence his or her followers in order to achieve a goal. In an organizational context this can be related to any type of goal an organization seeks to achieve; a leader must be able to help influence the constituents of an organization to achieve a goal, otherwise the organization will not be successful. Groups is the second part of

Northouse's critical component of leadership, where the groups are "the context in which leadership takes place" (Northouse, 3). The groups can be composed of very different constituents or individuals that can vary on the basis of different characteristics or settings (Northouse, 3). It is important to realize that with a group or groups a leader cannot lead, as he or she will have no one to lead towards a goal (Northouse, 3). In an organizational setting, groups can be defined as employees, stakeholders, or even management—or a combination of these constituents. The last critical component of leadership is "common goals," which means that both the leaders and followers agree upon collective goals (Northouse, 3). It is very important to understand that leaders and followers must agree upon the same goals, otherwise a leader is not truly leading a group. Leaders and followers must also work together to achieve these collective, mutual goals—which is a key component of leadership (Northouse, 3). In an organization a leader must understand the necessity of leading groups towards common goals, as success is dependent on it.

The three components of leadership—influence, groups, and common goals—are critically linked to many organizational factors relating to change within an organization. The ability to influence groups in the face of change within an organization is a great challenge, as Machiavelli stated years ago. Factors that can affect the ability to influence in an organization include strength of communication and transparency. Groups are important within organizational change as a leader must correctly assess which groups need to accept and support change and understand how ready these key groups are for

change. Common goals are important in an organization, especially during change, because the leaders and followers must share the same vision in order to achieve success through organizational change. Common goals are achieved through successful buy in and communication, which is very important for the leadership of an organization to achieve. Success of organizational change, especially within a merger, is dependent on a leader's ability to capitalize on the three key areas of leadership—influence, groups, and common goals. This paper will analyze how a leader can utilize strong leadership strategies to find success in a merger.

It is also very important to note the distinction of leadership and management within an organization. The two are very distinct and have different implications within an organization. John S. Burns in his study *Defining Leadership: Can We See the Forest for the Trees?* he writes, "It is important to first distinguish management from leadership. Management is the execution of technical/transactional solutions to technical problems where no adaptation/transformation is necessary" (Burns, 155). Burns introduces the important concepts of transactional and transformational leadership and he believes management is more of a form of transactional leadership. To Burns, transactional leadership occurs when "one person takes the initiative in making contact with others for the purpose of an exchange of valued things" (Burns, 150). Burns describes how other researchers understand the underlying self-interest in transactional leadership that is different than transformational leadership—which is more of the leadership described earlier involving leading and influencing groups towards common goals. Burns points

towards the belief that transformational leadership is “a process through which “one or more persons engage with others in such a way that leaders and followers raise one another to higher levels of motivation and morality” (Burns, 151). Transformational leadership is a process where followers change and are raised to new heights—as opposed to transactional leadership where followers are almost “used” in the pursuit of self-interest or gain. The distinction between leadership and management is evident through their relationship with transformational and transactional leadership respectively.

This paper focuses on leadership’s importance in change situations with an emphasis on leadership in a transformational context, rather than the managerial-transactional definition. Transformational leadership can shape the organization and take groups to new heights—which is why it is so important in difficult situations such as mergers. Managerial transactions are not nearly as effective in the face of change, as gain can be much more one sided and can limit an organization’s success.

## **VII. Culture**

Culture is a factor that is extremely important in change in mergers. In order to fully understand culture’s importance in a change context, it is important to understand what culture truly is and how it relates to leadership and change. Edgar H. Schein in his *Organizational Culture and Leadership* does a very thorough job of explaining the power and importance of an organization’s culture and the influence that leadership has on an organization’s culture. An organization’s culture is one of the most important characteristics of an organization that shapes the organization and gives it its own



identity. Culture is what makes an entity unique and what attracts the members of the organization. Interestingly, Schein describes culture as “an empirically based abstraction,” and by this he describes how culture are the “customs and rituals that societies develop over the course of their history” from an anthropological basis (Schein, 14). The following quote from Schein is a very good way to understand culture within an organization:

“.... culture is to a group what personality or character is to an individual. We can see the behavior that results, but we often cannot see the forces underneath that cause certain kinds of behavior. Yet, just as our personality and character guide and constrain our behavior, so does culture guide and constrain the behavior of members of a group through the shared norms that are held in that group” (Schein, 14).

This passage identifies culture is a guiding force within an organization that helps define values and ideals of the organization that create an identity. An essential factor of culture is that the values of the culture must be shared and agreed upon, so that this culture can be a unifying factor within an entity. Culture can also be a way for new members of a social group learn how to interact and what is “right” (Schein, 17).

According to Schein, culture is useful in so many different ways. Culture can help understand shared values within the organization as well as help the members of an organization think a certain way to achieve efficiency (Schein, 15). To help understand structural stability and the overall identity of a group, it is important to study culture (Schein, 18). After Schein describes the workings and message of culture, he formally

defines culture as “a pattern of shared basic assumptions learned by a group” that help develop patterns, solve problems, and help initiate structure (Schein, 18).

Artifacts, espoused beliefs and values, and basic underlying assumptions, according to Schein, are levels at which culture can be examined and understood.

Artifacts are visible characteristics of an organization, which can include clothing, style, architecture, location, tradition, and an image of a company (Schein, 24). Artifacts help convey the “climate” of a group and the behavior, but it is important to realize that one should not make strong assumptions based on artifacts alone (Schein, 25). Studying espoused beliefs and values of an organization helps examine culture through shared values and beliefs and shared assumptions; these shared values and beliefs help understand the group processes and interaction within an organization, by understanding how decisions are made and how beliefs and values affect decision making (Schein, 26).

Basic underlying assumptions are the last level that can help examine culture. Basic underlying assumptions are the “unconscious assumptions” and “taken-for-granted beliefs and values” that help determine decision making and determine group behavior (Schein, 29-30). By studying these levels, one can understand the identity of a group and understand how a group thinks and makes decisions. These three levels are very important when leadership is concerned, because leaders help influence the group decisions and group thinking. Schein writes, “the most central issue for leaders is to understand the deeper levels of a culture, to assess the functionality of the assumptions

made at that level, and to deal with the anxiety that is unleashed when those assumptions are challenged” (Schein, 33).

After Schein helps the reader gain a better understanding of what culture is and the important concepts of culture are, he begins to examine the importance of leadership within cultures further. Schein discusses the operator subculture, which refers to the culture of the “line”, the engineering and design subculture, which refers to the culture of the technology implementation, and the executive subculture. The executive subculture is what individuals would typically classify as the “leaders” of the organization; these leaders must be concerned with being able to observe and influence the “basic work of the organization” and understand how information is passing through all levels of the organization (Schein, 64). This is a very tough feat to do, because as an individual climbs up the hierarchy it is hard for him or her to maintain a strong connection with all levels of the hierarchy as they become more “impersonal” (Schein, 65). It is also important to realize that leaders often help create or shape culture and sometimes this culture can conflict with already existing culture (Schein, 71). This dilemma is an interesting topic to keep in mind: leaders within organizations must weigh the importance of pursuing his or her own goals and values, while understanding the entire organization’s goals and values at the same time.

Schein describes how leaders embed and transmit cultures within organizations, which relates strongly to change. Charisma is a very important part of leadership that helps transmit and convey messages (Schein, 235). Schein describes how charisma is

essential to the creation of culture, as it can inspire great vision and instill important values (Schein, 236). In this chapter, mechanisms are described which are “tools” that help leaders create a sound culture. These mechanisms include “artifacts” to keep in mind when trying to promote a culture. Some primary embedding mechanisms include what leaders pay attention to, how leaders react to crises, how leaders allocate resources, how leaders act as a role model, how leaders reward, and how leaders facilitate movement within the group (Schein, 237). All these factors are important issues that a leader should be aware of in a leadership position within a group. Some important factors relating to these mechanisms are consistency, awareness, clarity, and trustworthiness (Schein, 245-250). A leader who is successful in promoting a culture is a leader who keeps his emotion in check, is consistent with all members of the group, consistent with his actions and ideals, and is trustworthy in his actions. It is important for a leader to have an image in mind of an organization to create a culture that is consistent and strong; the leader must organize his group to abide by this organizational “theme” and convey a strong message. Learning about these key figures can ensure development of a strong culture that can enhance productivity within the group. Schein describes key ways to enhance culture through leadership positions that can be applied from an organizational change standpoint.

Change is a very important topic related to organizational culture, and it is important to learn how leadership can cope with organizational change. The general process of organizational change is described as a series of stages. The first period of

change is founding and early growth, where the primary culture creators remain and this culture is adhered to very strongly to help gain some preliminary organizational identity (Schein, 274). This beginning stage is where culture is born and resistance to change is strong (Schein, 275). The organization then goes through changes, due to “evolution” where experience and need for change occurs; this need for change can be due to technology, insight, and general growth (Schein, 275-284). Eventually, an organization will face a period of cultural decline, where traditions and myths will fade or become exposed as false, turnaround can create a high dose of change, and the organization can go through strong structural change through a merger or acquisition (Schein, 291-294). These changes in organization are key factors that can be very serious and shocking for an organization that is used to a consistent culture. This dealing with change is where leadership is crucial in dealing with cultural change.

In order to deal with cultural change, leaders need to make sure they understand the psychological state of a group during a period of change (Schein, 303). Anxiety is a large factor of change, in that individuals fear that change will result in a loss of power, a creation of incompetence, a fear of punishment, and a fear of loss of identity (Schein, 303-304). A leader must understand that this is the general feeling of anxiety and must combat this feeling to motivate his group. In order to do this, according to Schein, a leader must convey a “compelling positive vision” and change the cognitive thinking of the group by ensuring that the change will be beneficial for the culture, and will not be a sudden change, but rather gradual (Schein, 305-307). Many organizations encounter

change at one point or another and it is important to understand what the group is feeling and how to support an entity during a time of anxiety and stress during change.

### **VIII. Effectiveness and Strategy**

This portion of the paper is devoted to analyzing leadership and culture strategies than can be used in a merger or change context that can ensure success and analyzing and developing a framework for change strategy. Much research has been devoted in order to examine how leaders can achieve successful change, given a successful merger is often difficult to attain. It is also very important to realize many of the factors that are involved in a successful merger are heavily intertwined. This portion begins with leadership styles and effective outcomes.

In a change context, it is very important for leaders to examine levels of change readiness. Change readiness can be used to gauge and anticipate reactions to change and the degree to which change must be resonated within the company. A study conducted by Joseph B. Lyons, Stephanie D. Swindler, and Anne Offner of the Air Force Research Laboratory examines the importance of measuring change readiness. The researchers state, "The current study explored two important research questions: (1) what are the relevant predictors of change readiness for different personnel groups in a US military context; and (2) is change readiness a valid predictor of behavioral intentions to support/resist an organizational change initiative?" (Lyons, 468). One can see the value examining change readiness can have within an organization as it can help predict whether adoption of change can occur and whether behavior change will occur (Lyons,

461). The researchers also link change readiness to the idea of change leadership, which is the idea that change leadership “represents behaviors that support/solidify organizational change initiatives” and focuses on “specific, transient behaviors addressing an ongoing or impending change” (Lyons, 460). The researchers tested their hypotheses by administering a survey to 152 US Air Force officers, 125 enlisted Air Force members, and 118 civilians. The surveys measured perceptions of senior leadership behaviors of change communication, supervisor behavior of change communication, general leadership, change readiness, intentions, and tenure (Lyons, 460). The implications of the study were extremely interesting. The researchers found that senior leaders were the group that most strongly influenced change readiness among the enlisted Air Force members—and it was in fact the only unique predictor of change readiness (Lyons, 469). The researchers found that senior leadership was a very strong predictor of change readiness and change readiness in fact could be a strong predictor of change behavior within an organization. The research has some interesting implications:

“Senior leaders set the stage for the change initiative, they make decisions on resources and other organizational allocations and strategies, and they establish norms for creating urgency and support for the change initiative” (Lyons, 469).

These implications can show that when executives of a company decide to promote organizational change, it is important to achieve the buy in of senior leadership within the company in order to promote organizational change behaviors throughout the company. Senior leadership may create a feeling of trust and can smooth the process of organizational change—and can help indicate how ready an organization is for change.

Once change readiness has been examined within an organization, a leader must develop a strong change plan. Roger Gill writes,

“Without strategies for change, vision is a dream. Strategies are ways of pursuing the vision and mission; they are informed by vision, mission and values. Strategic plans are “road maps” of a changing terrain in which a compass (vision) is needed. Effective leadership entails developing, getting commitment to and implementing rational business strategies based on possible future scenarios for the organization” (Gill, 314).

This passage shows how strategy is important to the execution of a leader’s vision. There is no one most effective change management strategy as each change situation is extremely unique. But there are characteristics that are integral to a successful change strategy within an organization: strong communication, trust, and buy-in (Gill, 315). Gill writes, “An effective strategy for change entails creating a guiding coalition—putting together a group of people with enough power to lead the change—and getting it to work together as an effective team” (Gill, 315). This can be a very difficult challenge, especially in large, global companies, but it is necessary in order to achieve success. In addition to these key factors, John W. Moran and Baird K. Brightman describe what a change strategy needs to focus on. According to Moran and Brightman, change impacts purpose, identity, and mastery (Moran, 67). The researchers describe how a successful change plan must align people’s purposes during change in order to result in positive outcomes (Moran, 67). Moran and Brightman present leadership with the following purpose-related questions: “Why do people come here to work each day? Will this change violate or conform to that purpose(s)?” (Moran, 67). Identity is the next area



Moran and Brightman examine in relation to change impact. To Moran and Brightman changing identity involves understanding, “People need a sense of personal integrity and consistency over time. Change that strikes at the core of a person’s sense of who they are will activate powerful motivations to return things to the status quo (Moran, 67). Mastery is the last area Moran and Brightman examine; they hypothesize that threatening mastery can be seen as threatening survival, as mastery involves an employee’s overall skills, abilities, knowledge, and training (Moran, 67). If change threatens mastery to too great of a degree, it can be extremely detrimental to the change strategy. The factors of purpose, identity, and mastery are at the heart of a change management strategy—as it is important to understand change affects the human side of employees.

Moran and Brightman examine the general structure and cycle behind any organizational change strategy a leader must examine. Moran and Brightman describe how change is a cyclical and continuous process and a leader must examine several change phases outlined by the following, adapted diagram from Moran and Brightman:

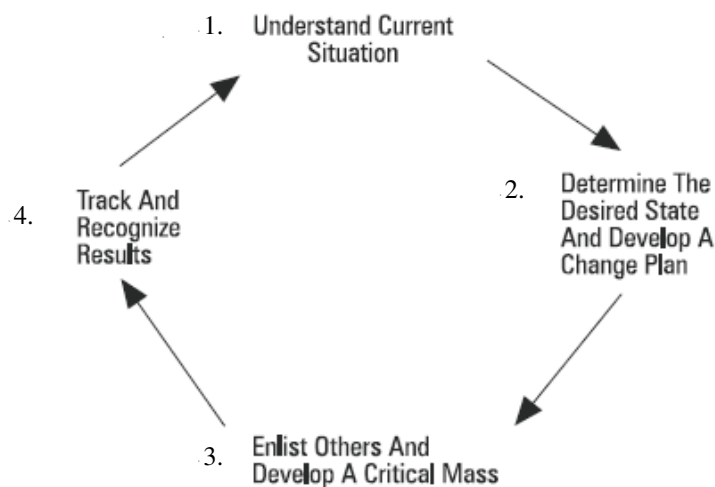

(Moran, 69)

Leaders must first understand the current situation of an organization through data, questioning, and analysis (Moran, 69). It is important leaders understand the global perspective of an organization through communicating with individuals and stakeholders at all levels of the organization—as this will help get a better understanding of what needs to be changed and where individuals fear change (Moran, 70). The second step is determining the desired state and developing a change plan, which requires taking account the individual characteristics of the situation as well as creating a clear vision (Moran, 70). The vision can be enhanced by taking into account many different perspectives and understanding how the vision can enhance overall efficiency of an organization (Moran, 70). Enlisting others and developing a critical mass is a very important third phase of the cycle. The researchers write,

“Implementing wide-reaching organizational change requires a wide range of communication skills and a depth of knowledge which no one individual can possess. You need the active help and support of others. Implementing change always involves a trial period. Usually you have to try different approaches and strategies before you start getting results. During this phase, you need people who are willing to experiment with new ideas and techniques and are not discouraged by initial failures” (Moran, 70).

This passage shows how change is not an individual process and why leadership is so important within change. A leader must communicate his vision clearly throughout the organization, especially to key members who must also promote change, in order to achieve trust and buy in behind his vision. The last step is the most straightforward step: tracking and stabilizing results. Leaders can use a variety of methods, such as surveys

and key performance indicators, to assess whether change efforts have been successful within an organization and whether the intended change was achieved.

It is essential a leader develop a strong change strategy—but are there some basic underlying factors that will determine the effectiveness of a leader in a change context? The study *Leadership competencies for implementing planned organizational change*, by Julie Battilana, Mattia Gilmartin, Metin Sengul, Anne-Claire Pache, and Jeffrey A. Alexander, seeks to answer this question. This research is linked to the research by Moran and Brightman as it examines leaders' abilities to communicate the need for organizational change as well as mobilizing others to accept change—factors that are linked to the change cycle discussed previously (Battilana, 424). The researchers focus on whether leaders are more effective through person-oriented behaviors or task-oriented behaviors in their promotion of organizational change (Battilana, 424). The researchers focus on the differences between task and relationship for strong reasons:

“To destabilize the status quo and paint a picture of the desired new state for followers, change leaders must communicate the need for change. Organization members need to understand why behaviors and routines need to change. Resistance to change initiatives is partly attributable to organization members' emotional reactions...Leaders skilled at interpersonal reaction are able to monitor and discriminate among their own and others' emotions, and to use this information to guide thinking and action...Leaders who are effective at task-oriented behaviors, on the other hand are organizational architects. Rather than communicating the need for change, task-oriented leaders are likely to concentrate their energies on developing the procedures, processes and systems required to implement planned organizational change. Because they are also more likely to keep their distance, psychologically, from their followers, task-oriented leaders may be less inclined to put emphasis on communicating activities” (Battilana, 424).

The researchers believe that differences in leadership style can heavily impact organizational change success and hypothesize leaders who are relationship-based are more likely to focus on the activities that go hand in hand with communicating the need for change, mobilizing organization members, and ultimately change success (Battilana, 424). Understanding how behavior style can impact promotion of change can be very important in a change strategy.

The researchers asked 95 managers from 81 different organizations to design and implement a change project in their respective organizations and were asked to fill out a survey to measure how implementation occurred; the researchers used the survey to measure various degrees of communication and mobilization efforts, with respect to leadership style, through a 5-point Likert scale. The results were very interesting and have some very strong implications. The researchers found their study to imply “leaders who are more effective at person-oriented behaviors are more likely to focus on the communicating activities of planned organizational change implementation” and “leaders who are more effective at task-oriented behaviors are more likely to focus on both the mobilizing and evaluating activities associated with planned organizational change implementation” (Battilana, 433). The implication task-focused leaders are more likely to focus on mobilizing and evaluating activities when one would think a relationship-based leader would tend to focus on these activities, shows how leaders need to balance task-focus and relationship-focus in order to successfully implement organizational change. Even though change is very people-focused, the development and execution of a strong strategy is based on a leader’s ability to balance the people-side as well as the strategy-

side of change. These findings show how it is important for a leader to be able to lead groups—the relationship-side—towards a strong vision—the task-side—of change.

In order to enlist others and develop a critical mass to promote change within an organization, a leader must use communication very effectively. Effective communication is extremely important due to the large size of many global companies today—if a leader wants to promote change, he must be able to articulate his vision of change clearly to all parts of the organization. Once a change decision has been made within a company, a leader should identify who the relevant stakeholders of the change are and who key change promoters must be within an organization. Stakeholders can be identified as any individual or employee who will be impacted by the planned change. This impact can be in the form of job tasks, procedures, and responsibilities as well as technology or terminology a worker is familiar with. Key promoters of change should be identified as well through analyzing organizational charts and understanding how facilitation of communication occurs within the company and who employees will listen to—such as the senior leaders in the U.S. Army research mentioned previously—and accept change vision from. Identifying key stakeholders and change promoters throughout in an organization involves close organizational analysis and mapping—but is necessary in order to ensure change success. An example of identifying key stakeholders and change promoters is:

A global toy manufacturer wants to unify its toy development processes within all divisions of the company. In order to unify the processes, the leaders are implementing new terminology and phases to ensure global

alignment and communication of toy stages. The impacted group involves the toy developers and engineers—who need to adopt new terminology as well as knowledge of reporting techniques. The key change promoters would be the executive engineers and senior engineers who must understand how adopting this change is beneficial to the efficiency of the organization and they must communicate this benefit to the toy developers and engineers.

Once the key impacted stakeholders have been identified, it is very useful to perform a job analysis as described by Ronald Riggio in *Industrial/Organizational Psychology*. Leaders must understand how future vision states impact current jobs and employees through changing day-to-day duties. According to Riggio a job analysis is “the systematic study of the tasks, duties, and responsibilities of a job and the knowledge, skills, and abilities needed to perform it” (Riggio, 56). Job analyses help understand the complexities, functions, and responsibilities of an employee and help understand how a specific position adds value in a department, or in the organization as a whole. Job analyses lead to job descriptions, which is a compilation of “detailed accounting of the tasks, procedures, and responsibilities required of the worker; the machines, tools, and equipment used to perform the job; and the job output (end product or service)” (Riggio, 57). By performing job analyses, leaders can understand the specifics of positions and can understand how change can affect training, development, evaluation, compensation, and planning (Riggio, 59). A leader must understand that change can affect many positions drastically in an organization and it is important to examine the current state of positions of individuals and understand how the future-changed vision of positions can impact many areas. By performing this analysis, leaders can avoid feelings of “fear” and

“threat” that change can place on employees and communicating a strong vision and plan for the future.

Communication is extremely important in mobilizing change promoters and supporters within the organization. Riggio suggests a model the communication process to consist of the sender, receiver, and the channel (Riggio, 279). Riggio defines the sender to be the “originator of the communication; the receiver to be the recipient; and the channel to be the vehicle through which the message will flow from the sender to the receiver” (Riggio, 279). Though the communication process may seem simple, there are many factors that affect effective communication, such as noise—or distractions, credibility of the sender, as well as relationships between senders and receivers (Riggio, 282-285). A model suggested by Riggio is adapted to show how leaders can use the communications process in a change context:

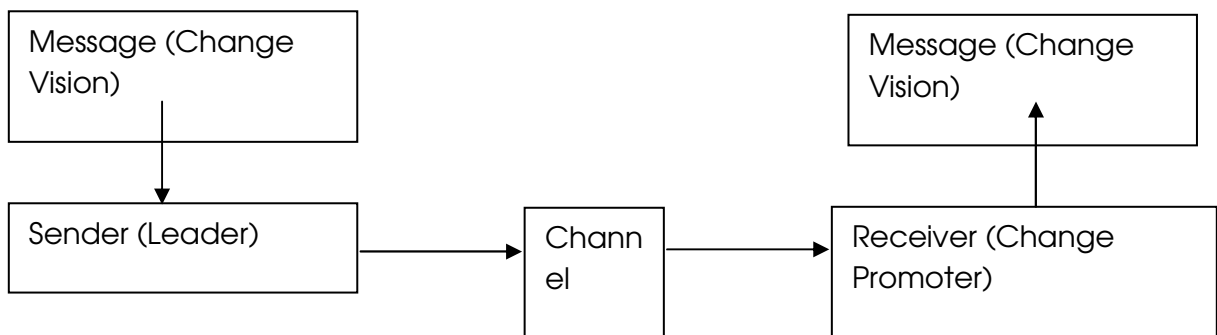

(Riggio, 279)

The process of enlisting others and developing a critical mass happens through a series of repetition of this process throughout the organization. The leader, who is the sender, uses effective channels to communicate his change-vision to the receiver, who is a change

promoter. The process then repeats once the change promoter accepts this vision and then becomes the sender and communicates the change-vision to key stakeholders, seen through the following diagram:

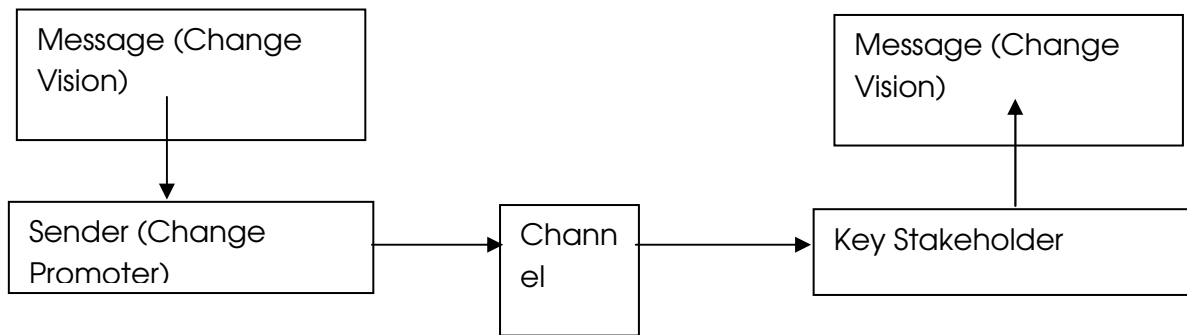

(Riggio, 279)

George P. Huber and William H. Glick, authors of *Organizational Change and Redesign*, write:

“Communication by strategic managers after the strategic decision (to promote change), both internally and externally, is as big a part of a strategic initiative as is gathering information prior to the strategic decision...In ill-defined, ambiguous, changing environments, managers tend to use a range of media, both rich and lean, to gain a full perspective on the environment and the strategies needed” (Huber, 136).

Huber and Glick build upon this “range of media” in strategy decisions as they state it is important for organizations to consider the variety of communication media within an organization to carry change messages (Huber, 142). The researchers describe media within organizations to be organizational communication vehicles, and each has its own strengths and benefits for communication—something a leader must analyze in order to increase communication effectiveness (Huber, 142). These communication vehicles can include telephone calls or messages, face-to-face interactions, meetings, memorandums,



formal reports, teleconferences, electronic mail, or web-based communications (Riggio, 280). Different organizations employ various communications vehicles and the strength of these vehicles depends on the uniqueness of the organization. For example, formal reports might be more effective in larger organizations than in a smaller organization, where face-to-face meetings are more receptive. A leader must decide how to communicate with key stakeholders and change promoters through the appropriate communication vehicle in order to ensure communication effectiveness.

The use of effective communication vehicles can be viewed as an effective use of downward communication, but upward and lateral communication during change is also very important. According to Riggio, downward communication “consists of those messages sent from superiors to subordinates,” and upward communication “is the flow of messages from the lower levels of the organization to the upper levels” (Riggio, 290). Lateral communication on the other hand is the communication “between people who are at the same level in the organizational hierarchy and is important when coworkers must coordinate their activities to accomplish a goal” (Riggio, 291). Lateral communication is important within an organization as it can help leaders gain feedback from their fellow leaders as well as different perspectives; leaders who use effective lateral communication can also build a change force by gaining the support of other leaders in the organization and who can help promote the change. Lateral communication can help enlist others and develop a critical mass that believes in the change vision and communicate the change throughout the organization. Upward communication can be particularly effective

through the use of feedback, which can be defined “as an acknowledgement that a message has been received and understood” (Riggio, 281). Feedback can help request for clarification and can help raise opinions and concerns about messages of change—which can be very helpful during change communication. By allowing feedback to be upwardly communicated, trust and commitment can be built, as employees feel part of the change process instead of just being a “victim” of change. Leaders who seek to effectively promote change should capitalize on allowing key stakeholders and change promoters to provide feedback as it can create trust and interest—which only strengthens the critical mass supporting change within the organization.

The issue of trust is heavily linked to leadership communication and transparency. In order for leaders to achieve buy in from stakeholders and change promoters, leaders need to ensure their communication is transparent and builds trust. The definition of leadership includes leading groups towards a vision, and trust and buy in is an essential element in this process. An interesting research case study by K.U. Menon and K.T. Goh show how trust and transparency were critical in managing the Severe Acute Respiratory Syndrome (SARS) in Singapore through communication (Menon, 376). Though the situation is different than an organizational context, the study shows how effective communication can result in trust, transparency, and overall success. As the SARS epidemic grew to become a large outbreak in Singapore and affected thousands of citizens, Singapore’s government used communication and transparency to manage the outbreak and educate the public (Menon, 378). Singapore’s government understood the

situation involved risk communication, which according to the researchers is, “all about the process of communicating honestly and effectively...” (Menon, 376). The government opened several “trust channels” by administering dialogues between political leaders and communities, dialogues with Singapore’s leaders, posters, booklets, collaterals, cartoons, advertisements, SARS Raps, SARS Songs, websites, hotlines, promotional campaigns, and even a SARS channel to help educate the public “honestly” about the state, situation, and danger of SARS (Menon, 379). The Singaporean government appeared extremely honest and open with their desire to help its citizens, educate the public, and control the outbreak. The government was successful in eventually earning the public’s trust through their transparent efforts:

“Earning the trust and confidence of Singaporeans was the more difficult process. It did not come naturally by just being “transparent”. In the initial weeks, fear was dominant and seen in all sorts of negative social behaviour as life ground to a halt...Earning the trust of the domestic populace meant taking no chances and government had to be seen to be doing very tangible things to reassure the populace. Ministers had to be seen to “walk the talk”...” (Menon, 381).

This passage shows how the government of Singapore gained the trust of the public through consistency and perseverance, though it was not an easy promise. This interesting case shows how effective communication and transparency can build trust and achieve success—as Singapore was very successful in educating Singaporeans about the SARS epidemic as well as containing the outbreak. Leaders of organizations can use this case to show how a government was effective in communicating and building trust with an entire population through transparency and use it in an organizational context. If a

leader wants to change behaviors and attitudes a step towards this is through building trust. Another reason why transparency can be very helpful in a time of change is due the fear and emotional anxiety trust can instill in employees and individuals. Building trust helps transition change and creates assurance when feelings of fear and anxiety are created.

The last step of the change cycle is tracking and recognizing results. This step is very important in order to define whether change was “successful”. The key to this step is defining “success” metrics that can quantify change before and after change is implemented. The success metrics can measure a variety of factors—both qualitative and quantitative. The key is correctly defining the metrics with the help of stakeholders and change promoters to help track and measure these results. The metrics can be tracked and measured by analyzing to find whether significant changes have been found in profitability ratios or in qualitative aspects. A common form of success metrics is administering surveys at a time before change is implemented and administering surveys post change. Surveys measuring success metrics are very helpful years after change has been implemented to continue to track and see whether the change vision has been met or are on track. Success metrics help a leader determine whether his change promotion has been successful and whether the leader, stakeholders, and change promoters successfully reached their goals and met their collective vision.

Leadership styles are very important in conjunction with communication. A study by Reinout E. de Vries, Angelique Backker-Pieper, and Wyneke Oostenveld investigates

the relationship between communication styles of leaders and outcomes (de Vries, 367).

The study examines charismatic leadership, human-oriented leadership, and task-oriented leadership specifically and hypothesizes leaders who exhibit charismatic and humane-oriented leadership will encounter higher levels of satisfaction among subordinates as well as satisfaction (de Vries, 370). The study was performed due to the belief communication is key in leadership and certain leadership styles result in better outcomes and higher performance (de Vries, 380). The researchers administered a survey to 279 government employees and measured ratings of a leader's communication style with respect to leadership outcomes of "perceived leader performance, satisfaction with the leader, and subordinate's team commitment" (de Vries, 372). The findings have some very interesting implications: they found charismatic and human-oriented leadership to be highly related with successful communication outcomes and assessment of leadership outcomes, whereas task-oriented was perceived as significantly less communicative (de Vries, 376). This study shows how charismatic and human-oriented leadership embody feelings of support, expressiveness, and assuredness—which lead to strong outcomes. In a change context the leadership styles of charismatic and humane-oriented can result in more success due to the receptiveness of subordinates—or employees and individuals in organizations.

A study conducted by David A. Swaldman and Mansour Javidan, *Alternative forms of charismatic leadership in the integration of mergers and acquisitions*, also

shows the importance of charismatic leadership in the change context of mergers and acquisitions. The researchers define charismatic leadership as:

“a relationship between an individual (leader) and one or more followers based on leader behaviors that engender intense reactions and attributions on the part of followers. We use the term relationship broadly to include both physically proximal and distant, or even nonexistent, interactions. In other words, an emotional or cognitive connection can be felt on the part of a follower toward a leader even if no direct contact is ever realized” (Waldman, 133).

The research shows how charismatic leadership appeals to the emotion of subordinates which is very important during change, as change is an emotional process. A charismatic leader can use his emotional appeal to help promote change by changing perceptions of change to be beneficial and for employees and individuals to stand strong behind the change vision. Furthermore, the researchers show charismatic leaders evoke senses of providing a sense of mission or purpose, articulating an inspirational vision, showing determination when accomplishing goals or change, showing confidence, and providing insights—all factors that can help a leader encounter organizational change success (Waldman, 133). Change is a very difficult process, but a leader who shows charismatic characteristics can find change to be easier to accomplish through providing a strong vision and attracting supporters.

John P. Kotter's *Leading Change: Why Transformation Efforts Fail* strongly supports the framework for change outlined by this paper. Kotter argues a variety of organizations fail because they simply do not follow key steps and factors that are essential for successful change. Kotter's key errors include:

1. “Not Establishing a Great Enough Sense of Urgency
2. Not Creating a Powerful Enough Guiding Coalition
3. Lacking a Vision
4. Undercommunicating the Vision by a Factor of Ten
5. Not Removing Obstacles to the New Vision” (Kotter, 97-103).

These errors are related to the change cycle and elements of leadership outlined by this paper—elements that have been shown to be key for success. Not establishing a great enough sense of urgency shows a leader has failed to show the benefit and need for change. Not creating a powerful enough guiding coalition shows a lack of execution in mobilizing change support and developing a critical mass that helps promote and own change throughout the organization. Lacking a vision and not removing obstacles to the new vision are critical pieces of leadership that leader must be able to correct if he wants to achieve any type of goal. Making sure visions exist and are attainable are of utmost importance in a change context as the leader must guide subordinates and employees towards this vision in order to achieve success. Lastly, undercommunicating the vision by a factor of ten further highlights the importance of a leader’s ability and commitment to communicating change and vision. If a leader does not employ communication effectively, stakeholders and change supporters will not exist—creating a lack of support that is crucial to effective change.

### **IX. Analyzing Cultures**

Organizational change and mergers involve impacts on companies’ cultures. Cultures are extremely unique and often give identity to an organization. It can be very difficult to change the culture of an established company as many employees may fear it

is an attack on their identity. But change must occur in order to attain successful results—especially in a merger situation. Specifically within the change cycle, culture is very important in relation to the stages of understanding the current situation and determining the desired state. Understanding change’s impact in a merger-change situation is crucial to success.

The first step in a change strategy involving change is to understand the current situation of the cultures. Clemente and Greenspan write, in *Winning at Mergers and Acquisitions*, “Too often, people attempt to define culture by saying that it defies definition...Corporate culture must be defined in order to factor it into all aspects of your integration planning” (Clemente, 179). Clemente and Greenspan believe the first step towards a successful merging of cultures is to define cultures, which they do by analyzing the internal and external variables of structure, emotion, and politics (Clemente, 180). Structure involves a company’s size, industry, geographic locale, and diversification (Clemente, 180-182). Structure is a basic factor to determine whether a merger of two companies will be successful, in order to determine whether there are some basic fundamental differences that will prohibit or hinder a successful integration. Emotional determinants are a very important factor that must be examined to understand the current state. Clemente and Greenspan believe there are ten key areas that must be analyzed when determining emotional fit between companies:

1. “The company’s leader
2. Management structure and style
3. Physical environment and atmospherics



4. Level of comfort and trust
5. Corporate definition of success
6. Level of autonomy desired
7. Level of commitment to superior, job, and company
8. Fairness of total compensation
9. Level of stress
10. Ultimate job satisfaction” (Clemente, 183).

These are ten elements that are very important to understanding the emotional state of employees of an organization. By analyzing these ten factors, a company’s identity is formed and one is able to understand how a company’s value and mission affects the company’s emotional state. By understanding the current state of these elements it is easier to determine cultural fit in a merger. The next step is to assess the current state of a company’s political determinants. Some companies experience dictatorial or “Black knight” culture, where the culture and instructions of the company are determined solely by the CEO or top level executives (Clemente, 188). This is how the company is used to running and how the company runs its day to day activities. A more lenient version of a dictatorial culture is the “Benevolent kingdom culture” where the CEO or executive still makes company decisions but he or she is influenced strongly by feedback and involvement with employees throughout the company—creating an environment where collaboration is allowed (Clemente, 188). Rule book culture is a culture focusing on “a set of conditions that have been established rather than on individual personalities” which follows guidelines, rules, codes, and routines; rule book culture puts less emphasis on the leader (Clemente, 189). The types of cultures that allow dispersion and sharing of power include enlightened culture, committee rule culture, and consensus rule culture

(Clemente, 189-190). The culture that allows the most employee autonomy and degree of employee power is autonomous culture, where employees are able to make big decisions on the company's behalf with their discretion (Clemente, 191). Some secondary organizational values that can be taken into account in analysis include, performance measurement, employee competition, reward systems, levels of formality, communication protocol, departmental interaction, employee risk taking degrees, commitment to individual growth, work-life balance, and conflict resolution (Clemente, 195).

There are a variety of ways leaders and analysts can administer in order to define culture and examine the current state of cultures. Some common ways include surveys, interview panels, employee interviews, examination of a company's written values and mission, and company data of employees (Clemente, 195). Though culture can be difficult to define as it can be very subjective and unique, it is important to attempt to formally define culture in order to determine cultural fit (Clemente, 195). Cultural fit is based on theories of social attraction—a theory that suggests individuals are “initially attracted to others whom they perceive to be similar to themselves” (Stahl and Mendenhall, 255). This definition makes sense as individuals often fear what is different or what they do not know—especially in a business setting where employees may have enjoyed routine, stability, and tradition for years. When a company undergoes a merger, fear of new individuals and identity can strike many employees—but if they believe a merging company appreciates the same values and ideas, the transition may be easier.

Gunter Stahl and Mark E. Mendenhall believe a sort of cultural audit must be performed prior to or immediately after a merger deal (Stahl and Mendenhall, 259). Stahl and Mendenhall describe a variety of questionnaires and audit tools that can help define current state that should administered to a variety of organizational levels, top teams, regions, and departments (Stahl and Mendenhall, 259). Stahl and Mendenhall believe this analysis is extremely useful as it can help in the:

1. “Establishing the extent of differences or gaps between combining organizations in those aspects or dimensions of culture that have proven links to integration problems which impact performance;
2. Deconstructing stereotypical cultural attitudes;
3. Establishing a means of placing value on the cultural assets of a potential target or partner;
4. Informing a culturally sensitive integration plan from the outset, which could be further refined by extended and more local use postmerger to target culture differences at department or subculture level” (Stahl and Mendenhall, 259).

These elements described are very important in understanding whether two organizations are compatible on a basic level and can also help devise future strategies on integrating cultures. Cultural audits may perhaps be most useful in determining whether a merger deal should take place and especially in helping determine the desired state.

Determining the desired state is essential to reaching the vision of the merging of two cultures. After strong analysis has been performed on the current states of cultures, leaders must examine the definitions of existing cultures and assess them for the next step, assuming a merger is feasible on a fundamental level. The next step should be analyzing the strengths and weaknesses of each culture. Leaders should ask the employees what they like and what they want to change—through this process leaders

can determine what must stay and what must change on an organizational wide basis. For a successful merger, a leader must take the “pros” of the two companies and eliminate the “cons” of the two companies and bring the two companies together into one. Leaders must also determine if the “pros” of one company are compatible with the new counterpart of the company and vice versa. Determining what values are crucial for the new, united company to exist is important in order for the newly formed company to begin to adopt a new culture of its own. A successful merger that creates this new culture will hold remnants of past cultures that proved to be particularly effective in the past and can help attain success in the future.

Some common myths exist with regards to cultural adaptation in mergers. Fubini, Price, and Zollo describe two common merger myths that pervade the strategy: the survival of the fittest myth and the cultural integration myth (Fubini, 49). The survival of the fittest myth is the belief that a culture of one company will dominate and take over the “weaker” culture of the other company in a merger (Fubini, 49-50). Fubini and fellow researchers suggest that the culture may be dominated over a period of time and may be a gradual process (Fubini, 50). Interestingly, they also suggest some leaders are determined to make sure the culture they channel dominate the other culture in an intentional, yet secretive fashion (Fubini, 50). The cultural integration myth differs in the belief “culture can be reshaped at will during the hectic integration period” which is fundamentally wrong because in this case, employees feel “defeated” when a culture dominates another culture at the end of the integration process (Fubini, 49). Leaders should understand these

myths and take steps to debunk these myths in their integration strategy. As mentioned before, to avoid the domination or elimination of one culture for another—which turns into a hostile acquisition, leading to feelings of fear and failure—a leader needs to develop a strong cultural transformation strategy before implementation. This strategy needs to promote a new culture that champions the strengths and uniqueness of both and combines them into a stronger, more united company that will only enjoy future success. But what are these steps that will help create a successful cultural transformation?

The answer to find the steps that will help create a successful cultural transformation are held in Frances Hesselbein's *The Key to Cultural Transformation*. The steps Hesselbein describe are related to change strategies and can be viewed as a change strategy within a larger change framework that can be implemented within culture. He writes,

“From experience and observation, there are seven essential steps to transform a culture through a changed organization:

1. Scanning the environment for the two or three trends that will have the greatest impact upon the organization in the future.
2. Determining the implications of those trends for the organization.
3. Revisiting the mission—answering Peter Drucker's first classic question, “What is our mission?” and examining our purpose and refining it until it is a short, powerful, compelling statement of why we do what we do.
4. Banning the old hierarchy we all inherited and building flexible, fluid management structures and systems that unleash the energies and spirits of our people.
5. Challenging the gospel of “the way we've always done it” by questioning every policy, practice, procedure, and assumption, abandoning those that have little use today or will in the future—and keeping only those that reflect the desired future.

6. Communicating with the few powerful, compelling messages that mobilize people around mission, goals, and values—not with 50 messages that our people have trouble remembering.
7. Dispersing the responsibilities of leadership across the organization, so that we have not one leader, but many leaders at every level of the enterprise” (Hesselbein, 4).

One can see transforming a culture through a changed organization is not an easy process. Many steps must be performed in order to promote this new culture.

Hesselbein’s strategy is related to many of the strategies described in this paper.

Scanning the environment for key trends that will have a great impact relates to understanding the strengths of each culture and company through due diligence and analysis; these key trends will be the trends that will help unify the new parts of the merger. Revisiting the mission, as described by Drucker, is important in that leaders must have a united vision and sense of purpose especially in a merger, as conflicting visions can cloud missions and inhibit success. Leaders must understand what their collective vision is and the purpose of a merger in order to communicate this vision across the organization. Banning the old hierarchy and challenging old ways shows the importance of communicating the benefits of change and takes into the structural factors of culture. By challenging old ways, a stronger structural culture can be formed through uniting companies. Communicating with powerful messages and dispersing responsibilities shows how cultural change is a group effort and how important effective communication is in a merger—as exhibited in overall change strategies. Interestingly, a study conducted by Marie H. Kavanagh titled *The Impact of Leadership and Change Management Strategy on Organizational Culture and Individual Acceptance of Change during a*

*Merger* supports the idea of the importance of leadership: transparency during a change process helps determine evaluations of a leader and who individuals perceive as leaders in the organization (Kavanagh). These seven steps are extremely important in changing the culture in a merger as they also appeal to the political and emotional factors of cultures. Creating successful cultural change involves changing the emotional states and political structures of existing cultures and combining them to create a new culture that is highly successful in its performance while satisfying employees.

### **X. An Application of Strategy**

In an effort to apply the change strategies outlined by this paper in a real world context, an examination of the Daimler-Chrysler merger will be performed. The examination will serve to determine how applying strategies in this paper could have resulted in a successful outcome. The first step again is to understand the current situation and define culture and relevant characteristics of the organization. Leaders should have understood the fundamental differences in cultures between Daimler and Chrysler were extremely strong. Daimler's authoritative, dictatorial style was vastly different from Chrysler's autonomous and independent culture. The leaders of Daimler and Chrysler should have audited cultures and examined the large gaps in cultures.

The next are where DaimlerChrysler failed was in the issue of transparency and vision. The lack of transparency in leadership negotiations was a large factor in the failure of the merger. The fact Daimler leaders were simply using Chrysler to gain a foothold in the American market shows how Chrysler and Daimler failed in creating a

united vision. Daimler's self-serving vision was vastly different than Chrysler's vision—though both might have wanted benefits through the counterpart. Daimler and Chrysler needed to understand how they could work together as one and enjoy success together instead of using each other to increase profits and revenue.

The lack of vision and transparency hurt the next phase of the change cycle, enlisting others and mobilizing support through communication. Hartley writes, "In reality, Chrysler had become only a division of Daimler. In interviews with the media, Schrempp (CEO of Daimler) admitted that subjugation of Chrysler had always been his intention, this a duplicity of no small moment" (Hartley, 310). The openness with which Daimler revealed its intent to simply use Chrysler shows how leaders were not unified in vision once again. The fact leaders were not unified made it impossible for a change vision to be promoted within the company. There was no understanding of how the change and merger would benefit both sides—and in fact there was no benefit—and the company took a strong turn for the worse. Hartley writes, "Seldom has a merger turned out worse, and so quickly. Perhaps because of morale problems and too much attention given to smoothing relations between Detroit and Stuttgart, the bottom line of Chrysler was wracked" (Hartley, 308).

The leaders should have created a unified vision before the integration took place. Leaders of Daimler and Chrysler needed to act transparently and understand how their missions and purposes could unite to create the greatest automobile company in the world. Creating this vision would educate leaders and managers within the company of



the benefits of merging and these benefits could be communicated throughout the company and resonate within all employees—which would help create successful change and increase in profits. Instead, Chrysler alone lost close to seven billion dollars after the merger, as it was being used by Daimler.

The last step is that DaimlerChrysler should have understood their merger was not successful from the beginning, through analyzing and examining data that could indicate to mergers success. Instead, the leaders appeared to be confident—thinking that a merger of titans would automatically result in a domination of the automobile market. In fact, the opposite occurred. If DaimlerChrysler understood its unification was not meeting key performance indicators of success, steps should have been taken immediately to correct the problems. Solutions could have been addressing the strong cultural problems, communicating the benefits of change, and aligning visions. Instead, nothing was done and a colossal merger resulted in massive failure and loss.

## **XI. Conclusion**

As this paper demonstrates, change is a very difficult process. Change involves analysis of many complex factors—especially leadership and culture. It is no wonder why so many mergers fail, as leaders may not realize the extent of what they need to analyze when deciding to merge. This paper shows extensive analysis needs to be performed before a merger should be announced—to see whether companies are compatible on a basic level and to understand the complexity of the factors involved in change. Mergers are not an easy feat to accomplish, but with careful internal and external

analysis of leadership and culture, companies can make the right decisions. Leadership and culture are the heart of organizations and companies, and individuals need to look past the numbers to understand the importance of leadership and culture in the face of change.

### Works Cited

- Battilana, Julie, Mattia Gilmartin, Metin Sengul, Anne-Claire Pache, and Jeffrey A. Alexander. "Leadership Competencies for Implementing Planned Organizational Change." *The Leadership Quarterly* 21.3 (2010): 422-38. Print.
- Burns, J. S. "Defining Leadership: Can We See the Forest for the Trees?" *Journal of Leadership & Organizational Studies* 3.2 (1996): 148-57. Print.
- "Change." *Merriam-Webster Dictionary*. Web. <<http://www.merriam-webster.com/dictionary/change>>.
- Clemente, Mark N., and David S. Greenspan. *Winning at Mergers and Acquisitions: the Guide to Market-focused Planning and Integration*. New York: John Wiley, 1998. Print.
- "Daimler, Chrysler and the Failed Merger - Management Case Study." *Business and Management Case Studies, Case Study Resources*. Web. 21 Nov. 2011. <<http://www.casestudyinc.com/daimler-chrysler-and-the-failed-merger>>.
- "Daimler-Chrysler Merger: A Cultural Mismatch?" *ICMR*. IBS Center for Management Research. Web. <<http://www.icmrindia.org/casestudies/catalogue/Business%20Strategy1/Daimler-Chrysler%20Merger%20A%20Cultural%20Mismatch.htm>>.
- "Daimler-Chrysler: Why the Marriage Failed - AutoObserver." *Automotive Industry News, Automotive News, AutoObserver, Detroit, Edmunds - AutoObserver*. Web. 21 Nov. 2011. <<http://www.autoobserver.com/2007/05/daimler-chrysler-why-the-marriage-failed.html>>.

- De Vries, Reinout E., Angelique Backker-Pieper, and Wyneke Oostenveld. "Leadership = Communication? The Relations of Leaders' Communication Styles with Leadership Styles, Knowledge Sharing and Leadership Outcomes." *J Bus Psychol* 25 (2010). Print.
- Fubini, David, Colin Price, and Maurizio Zollo. *Mergers: Leadership, Performance and Corporate Health*. Houndmills, Basingstoke, Hampshire: Palgrave Macmillan, 2007. Print.
- Gill, Roger. "Change Management--or Change Leadership?" *Journal of Change Management* 3.4 (2002): 307-18. Print.
- Hambrick, Donald C., David Nadler, and Michael Tushman. *Navigating Change: How CEOs, Top Teams, and Boards Steer Transformation*. Boston, MA: Harvard Business School, 1998. Print.
- Hartley, Robert F. *Management Mistakes and Successes*. Hoboken, NJ: Wiley, 2011. Print.
- Hesselbein, Frances, and Rob Johnston. *On Leading Change: a Leader to Leader Guide*. San Francisco: Jossey-Bass, 2002. Print.
- Hollmann, Julia, Aletéia De Moura Carpes, and Thiago A. Beuron. "The DaimlerChrysler Merger - a Cultural Mismatch?" *Revista De Administração Da UFSM* 3.3 (2010). Print.
- Huber, George P., and William H. Glick. *Organizational Change and Redesign: Ideas and Insights for Improving Performance*. New York: Oxford UP, 1993. Print.
- Kavanagh, Marie H., and Neal M. Ashkanasy. "The Impact of Leadership and Change Management Strategy on Organizational Culture and Individual Acceptance of

Change during a Merger." *British Journal of Management* 17.S1 (2006): S81-103. Print.

Kotter, John P. "Leading Change: Why Transformation Efforts Fail." *Harvard Business Review* (2007). Print.

Machiavelli, Niccolo. *The Prince*. New York: Dover Publications, 1992. Print.

Menon, K. U., and K. T. Goh. "Transparency and Trust: Risk Communications and the Singapore Experience in Managing SARS." *Journal of Communication Management* 9.4 (2005). Print.

"Mergers and Acquisitions: Definition." *Investopedia.com - Your Source For Investing Education*. Web. 21 Nov. 2011.  
<<http://www.investopedia.com/university/mergers/mergers1.asp>>.

Moran, John W., and Baird K. Brightman. "Leading Organizational Change." *Career Development International* 6.2 (2001): 111-19. Print.

"News Headlines." *CNBC Mobile Home*. Web. 21 Nov. 2011.  
<[http://www.cnbc.com/id/34467713/Top\\_10\\_Best\\_and\\_Worst\\_Mergers\\_of\\_All\\_Time?slide=16](http://www.cnbc.com/id/34467713/Top_10_Best_and_Worst_Mergers_of_All_Time?slide=16)>.

"News Headlines." *CNBC*. Web. 21 Nov. 2011.  
<[http://www.cnbc.com/id/34467713/Top\\_10\\_Best\\_and\\_Worst\\_Mergers\\_of\\_All\\_Time?slide=16](http://www.cnbc.com/id/34467713/Top_10_Best_and_Worst_Mergers_of_All_Time?slide=16)>.

Nilakant, V. ., and S. Ramnarayan. *Change Management: Altering Mindsets in a Global Context*. New Delhi: Response, 2006. Print.

Northouse, Peter Guy. *Leadership: Theory and Practice*. Thousand Oaks, CA: Sage, 2004. Print.

Riggio, Ronald E. *Introduction to Industrial/organizational Psychology*. Upper Saddle River, NJ: Prentice Hall, 2003. Print.

Stahl, Gunter K. "Getting It Together: The Leadership Challenge of Mergers and Acquisitions." *Leadership in Action* 24.5 (2004): 3-6. Print.

Stahl, Gu□nter K, and Mark E. Mendenhall. *Mergers and Acquisitions Managing Culture and Human Resources*. Stanford, CA: Stanford Univ., 2005. Print.

Waldman, David A., and Mansour Javidan. "Alternative Forms of Charismatic Leadership in the Integration of Mergers and Acquisitions." *The Leadership Quarterly* 20.2 (2009): 130-42. Print.