

2007

## Diclity in *Bouteloua* (Poaceae: Chloridoideae): Implications for the Evolution of Dioecy

Michael S. Kinney

*Rancho Santa Ana Botanic Garden, Claremont, California*

J. Travis Columbus

*Rancho Santa Ana Botanic Garden, Claremont, California*

Elizabeth A. Friar

*Rancho Santa Ana Botanic Garden, Claremont, California*

Follow this and additional works at: <http://scholarship.claremont.edu/aliso>



Part of the [Botany Commons](#), and the [Ecology and Evolutionary Biology Commons](#)

---

### Recommended Citation

Kinney, Michael S.; Columbus, J. Travis; and Friar, Elizabeth A. (2007) "Diclity in *Bouteloua* (Poaceae: Chloridoideae): Implications for the Evolution of Dioecy," *Aliso: A Journal of Systematic and Evolutionary Botany*: Vol. 23: Iss. 1, Article 45.

Available at: <http://scholarship.claremont.edu/aliso/vol23/iss1/45>

## DICLINY IN *BOUTELOUA* (POACEAE: CHLORIDOIDEAE): IMPLICATIONS FOR THE EVOLUTION OF DIOECY

MICHAEL S. KINNEY,<sup>1,2</sup> J. TRAVIS COLUMBUS, AND ELIZABETH A. FRIAR

Rancho Santa Ana Botanic Garden, 1500 North College Avenue, Claremont, California 91711-3157, USA

<sup>1</sup>Corresponding author (kinneym@missouri.edu)

### ABSTRACT

The New World grass genus *Bouteloua* (Chloridoideae: Cynodonteae) comprises 57 species, 13 of which produce unisexual spikelets and hence are diclinous. Andromonoecy, gynodioecy, monoecy, trimonoecy, and dioecy all occur in the genus, and ten species are known to express more than one of these breeding systems. Employing a phylogenetic estimate based on parsimony analysis of DNA sequences from the ITS (nrDNA) and *trnL-F* (cpDNA) regions representing 35 species of *Bouteloua*, including ten of 13 diclinous species, we used parsimony character state reconstructions to investigate the evolution of unisexual spikelets and breeding systems. Our specific goals were to estimate (1) the ancestral condition in the genus, (2) the number of times spikelet unisexuality has arisen and/or been lost, and (3) the evolutionary pathways leading to dioecy and the other breeding systems. Although a number of related genera are diclinous, the reconstructions suggest that the common ancestor of *Bouteloua* probably was not diclinous. Spikelet unisexuality appears to have evolved two to seven times in the genus, but precisely how many times is uncertain; zero to four reversals to hermaphroditism are inferred. The reconstructions show andromonoecy arising from monoecy, and gynodioecy arising from monoecy. Neither andromonoecy nor gynodioecy are implicated in the origin of monoecy or dioecy. Monoecy is shown to evolve from monoecy and dioecy, and dioecy from monoecy and monoecy. Polyploidy and arid environments are possible factors in the evolution and variability of breeding systems in *Bouteloua*.

Key words: andromonoecy, *Bouteloua*, breeding systems, dicliny, dioecy, evolution, gynodioecy, monoecy, monoecy, Poaceae, unisexual spikelets.

### INTRODUCTION

The evolution of unisexual flowers is a topic of great interest to plant biologists. Most angiosperms produce hermaphrodite (bisexual, perfect) flowers, whereas 20–30% of species develop flowers in which either male (stamens) or female (pistils) organs do not reach functional maturity (Yampolsky and Yampolsky 1922; Richards 1997). Darwin (1876) remarked that the separation of the sexes in plants probably evolved to reduce self-fertilization and/or lower the cost of reproductive investment. Whether the driving force in the evolution of unisexual flowers is promotion of outcrossing or sexual resource allocation has remained a topic of intense discussion (Darwin 1877; Bawa 1980; Givnish 1980, 1982; Thomson and Barrett 1981; Lloyd 1982; Ross 1982; Willson 1982; Baker 1984; Renner and Ricklefs 1995).

Dicliny has been defined by some authors as functional male and female organs developing in separate flowers (termed staminate and pistillate flowers, respectively) on the same plant (monoecy) or different plants (dioecy) (Jackson 1928; Lincoln et al. 1998). However, these terms are not sufficient to encompass the array of breeding systems involving unisexual flowers that are known to occur in angiosperms. Lloyd (1972) employed “partial dicliny” to describe a breeding system involving both hermaphrodite and unisexual flowers. In this paper, we define dicliny broadly to include any breeding system that involves unisexual flowers,

whether or not some or all individuals also produce hermaphrodite flowers. The contrasting term is monoecy, in which only hermaphrodite flowers are produced.

Dioecy is an extreme expression of dicliny (i.e., complete separation of the sexes). Based on the occurrence of dioecious species in a diversity of higher taxa across angiosperms, it is evident that this breeding system has evolved independently numerous times (Lewis 1942; van der Pijl 1978; Lloyd 1982). Multiple origins of dioecy were revealed in a phylogenetic analysis of monocots by Weiblen et al. (2000). Evolutionary transitions to dioecy directly from monoecy or via pathways involving diclinous intermediates are implicated (Bawa 1980; Weiblen et al. 2000). As detailed below, the intermediates most often proposed are gynodioecy (pistillate and hermaphrodite flowers on separate plants [genets]) and monoecy, and it has been suggested that dioecy is the end point in the pathway of breeding system evolution (Westergaard 1958; Lloyd 1972; Charlesworth and Charlesworth 1978; Bawa 1980; Ross 1982; McArthur et al. 1992). However, this may not always be the case. Rieseberg et al. (1992) showed that androdioecy (staminate and hermaphrodite flowers on separate genets) is likely derived from dioecy in Datisaceae. In addition, diclinous forms typically thought to be evolutionary intermediates, such as gynodioecy, may actually be more evolutionarily stable breeding systems than originally believed (Weiblen et al. 2000).

Many authors have proposed that gynodioecy is an intermediate stage in the evolution of dioecy (Darwin 1877; Ross 1970, 1982; Lloyd 1975, 1976; Charlesworth and Charlesworth 1978; Charlesworth 1989; Maurice et al. 1993). The first step towards dioecy in a hermaphrodite population is

<sup>2</sup> Present address: Division of Biological Sciences, 311 Life Sciences Center, 1201 Rollins Street, University of Missouri–Columbia, Columbia, Missouri 65211-7310, USA.

Table 1. Diclinous species of *Bouteloua* and associated breeding systems (Columbus et al. 1998, 2000) and chromosome numbers ( $x = 10$ ). Nomenclature follows Columbus (1999). \* Not represented in this study.

Species	Breeding system	Chromosome number ( $2n$ )
<i>B. bracteata</i> (McVaugh) Columbus	monoecy, dioecy	unknown
<i>B. chondrosioides</i> (Kunth) Benth. ex S. Watson	monoecy, gynodioecy	20, 22, 40 (Gould 1980)
<i>B. dactyloides</i> (Nutt.) Columbus	monoecy, dioecy	20, 40, 56, 60 (Nielsen 1939; Gould 1968; Reeder 1968, 1971, 1984; Löve and Löve 1981)
<i>B. dimorpha</i> Columbus	monoecy, dioecy	40, 43 (Gould 1966; Reeder 1967)
<i>B. diversispicula</i> Columbus	monoecy, dioecy	20, 40, ca. 60, 60 (Pierce 1979; Reeder 1984)
* <i>B. erecta</i> (Vasey & Hack.) Columbus	andromonoecy, monoecy	20 (Pierce 1979)
* <i>B. griffithsii</i> Columbus	andromonoecy, monoecy	20 (Pierce 1979)
<i>B. mexicana</i> (Scribn.) Columbus	monoecy, dioecy	20 (Reeder 1967)
<i>B. multifida</i> (Griffiths) Columbus	andromonoecy, monoecy	20 (Pierce 1978, 1979)
<i>B. nervata</i> Swallen	dioecy	40 (Reeder 1967)
<i>B. reederorum</i> Columbus	monoecy, dioecy	40 (Reeder 1967)
<i>B. stolonifera</i> Scribn.	dioecy	60 (Reeder 1971)
* <i>B. varia</i> (Swallen) Columbus	andromonoecy, monoecy, trimonoecy	20 (Pierce 1979)

the occurrence of mutations that impart male sterility in either nuclear or cytoplasmic genes (Lewis 1942; Lloyd 1975, 1976; Ross and Weir 1976; Charlesworth and Charlesworth 1978, 1981; Charlesworth 1989; Gouyon et al. 1991; Maurice et al. 1993). Charlesworth and Charlesworth (1978) theorized that after female plants are established alongside hermaphrodites in a population, there will be increased selection for male function in hermaphrodites if the females demonstrate a significant advantage in seed production. Selection for male function in the hermaphrodites would result in subsequent reduction of female function until only male function is retained, establishing dioecy. This model is possible only if male sterility is the result of mutations in the nuclear genome, or a combination of cytoplasmic and nuclear factors (Lloyd 1975, 1976; Ross and Weir 1976; Charlesworth and Charlesworth 1978; Charlesworth 1989). If male sterility is strictly cytoplasmically determined (cytoplasmic male sterility), males will not replace hermaphrodites and dioecy will not be established (Charlesworth 1989; Maurice et al. 1993).

Monoecy is another frequently proposed intermediate in the evolution of dioecy from hermaphroditism (Lewis 1942; Westergaard 1958; Lloyd 1972; McArthur et al. 1992; Charlesworth and Charlesworth 1978; Bawa 1980; Renner and Ricklefs 1995). It is thought that the transition from monoecy to dioecy may occur frequently, because theoretically only a mutation altering the ratio of male and female flowers on individual plants would be required, as the ability to suppress male or female function would have evolved earlier in the monoecious lineage (Lloyd 1972; McArthur et al. 1992; Renner and Ricklefs 1995). Support for the prevalence of this pathway includes the frequent occurrence of monoecy and dioecy in closely related taxa. This is observed so commonly that authors have remarked that the presence of monoecy is the single most important predictor of dioecy in closely related taxa (Yampolsky and Yampolsky 1922; Lewis 1942; Renner and Ricklefs 1995).

Phylogenetics, which has seen much growth and widespread application in recent decades, is a powerful approach for understanding plant breeding system evolution (reviewed in Weller and Sakai 1999). In particular, phylogenetic anal-

yses of molecular data can provide new insights into the evolution of reproductive traits and avoid what has been referred to as circularity in logic when breeding system characters are included in the data matrix that produces the phylogenetic estimate (Hart 1985; Weller and Sakai 1999; but see de Queiroz 2000). Using this approach, Hart (1985) demonstrated that dioecy probably evolved from gynodioecy in *Lepechinia* Willd. (Lamiaceae). Weller et al. (1995) showed that gynodioecy is likely intermediate in the evolution of dioecy in *Schiedea* Cham. & Schlttdl. and *Alsinidendron* H. Mann (both Caryophyllaceae). Combining several phylogenies, Weiblen et al. (2000) concluded that shifts from monoecy directly to dioecy have occurred most frequently across monocots. Thus, mapping breeding system characters onto molecular phylogenies has led to new insights into the evolution of dioecy.

The New World grass genus *Bouteloua* Lag. (Chloridoideae: Cynodonteae) displays a great deal of breeding system variation. The predominantly North American genus comprises 57 species, 13 of which develop unisexual spikelets (Table 1; Columbus et al. 1998, 2000; Columbus 1999). Multiple forms of dicliny occur in the group, including andromonoecy (staminate and hermaphrodite flowers on the same plant), gynodioecy, monoecy, trimonoecy (staminate, pistillate, and hermaphrodite flowers on the same plant), and dioecy. In addition, most of the diclinous species exhibit two forms of dicliny, and in *B. varia* three forms have been reported (Pierce 1979; Table 1). Eight species are facultatively (i.e., accompanied by monoecy) or obligately dioecious. Except for *B. chondrosioides* (Reeder and Reeder 1966), dimorphism of the spikelet and/or inflorescence accompanies floral unisexuality, especially in *B. bracteata*, *B. dactyloides*, *B. dimorpha*, and *B. reederorum*.

Recent molecular phylogenetic studies indicate that *Bouteloua* sensu Columbus (1999) is monophyletic based on maximum parsimony analyses of DNA sequence data from the internal transcribed spacer region (ITS; nrDNA), including the 5.8S gene, and the *trnL* intron, *trnL* 3' exon, and *trnL-trnF* intergenic spacer (cpDNA) (Columbus et al. 1998, 2000). These phylogenetic estimates infer the repeated gain and/or loss of dicliny in the genus. In the present study, we

endeavor to better understand the evolution of unisexual spikelets and breeding systems in *Bouteloua* by rigorously examining the phylogenies reported by Columbus et al. (1998, 2000), employing different models of character evolution. We address the following questions: What is the ancestral condition in *Bouteloua*? How many times has spikelet unisexuality arisen and/or been lost in the genus? What evolutionary pathways are implicated in the origin of dioecy and the other breeding systems?

#### MATERIALS AND METHODS

##### *Selecting the Phylogenetic Tree*

To analyze the evolution of spikelet unisexuality and breeding systems in *Bouteloua*, we arbitrarily selected one of six phylogenetic trees from the parsimony analysis of the combined sequence data of ITS (including 5.8S) and *trnL-F* of Columbus et al. (2000). This analysis included 35 of 57 species of *Bouteloua* sensu Columbus (1999), including ten of 13 species known to have unisexual spikelets (Table 1; Columbus et al. 1998). *Bouteloua varia*, reported to exhibit andromonoecy, monoecy, and trimonoecy (Pierce 1979), was not sampled by Columbus et al. (2000) because the *trnL-F* region sequence was not available at the time. However, in a previously published ITS phylogeny (Columbus et al. 1998), *B. varia* is sister to the monoecious/dioecious *B. diversispicula* with statistical support (bootstrap  $\geq 70\%$ ; Hillis and Bull 1993). Other diclinous species not represented in the combined data phylogeny are *B. erecta* and *B. griffithsii*. These two species along with *B. diversispicula* and *B. varia* were once included in *Cathestecum* J. Presl, a morphologically cohesive and likely monophyletic group. In addition, not all monoclinal species of *Bouteloua* are represented in this tree, but most of the missing species were sampled for the Columbus et al. (1998) ITS study, wherein these species are in statistically supported clades consistent with the Columbus et al. (2000) study.

In the Columbus et al. (2000) study, the ITS and *trnL-F* phylogenies are largely concordant with each other and the combined phylogeny. Most differences among the ITS (Columbus et al. 2000), *trnL-F*, and combined phylogenies involve nodes lacking statistical support. However, conflict exists in the well-supported clade comprising *Bouteloua bracteata*, *B. chondrosioides*, and *B. dimorpha*. *Bouteloua bracteata* and *B. dimorpha* are sister in the ITS and combined trees, whereas *B. bracteata* is sister to *B. chondrosioides* in the *trnL-F* phylogeny. The incongruent relationships are statistically supported in both phylogenies. The impact of this on character state reconstruction will be discussed below.

##### *Character Mapping and Ancestral State Reconstruction*

The characters evaluated—the presence or absence of unisexual spikelets and breeding system type—were mapped onto the phylogeny, and their evolution was traced using MacClade vers. 4.0 (Maddison and Maddison 2000). Character states were coded and scored based on information in the literature (Columbus et al. 2000 and references therein).

Spikelet sexuality was coded as a single character with two states: unisexual spikelets absent (0) or present (1). In the case of *Bouteloua chondrosioides*, this species is poly-

morphic for the character because both monoclinal and gynodioecious populations have been reported (Reeder 1969; Columbus et al. 2000). Terminal taxa coded as polymorphic for a character can make inference of ancestral states problematic (Maddison and Maddison 2000). To address this problem, we split *B. chondrosioides* into two terminal taxa, each representing a different state (Nixon and Davis 1991).

Breeding system was coded as a single unordered character with five states corresponding to the breeding systems represented in this study: monoecy (0), monoecy (1), dioecy (2), andromonoecy (3), and gynodioecy (4). Eight species are polymorphic for breeding system (Table 1); these were split into multiple terminal taxa in the manner described above.

To reconstruct ancestral character states, both accelerated (ACCTRAN) and delayed transformation (DELTRAN) optimizations were performed (Maddison and Maddison 2000). All transitions were considered equally likely. ACCTRAN and DELTRAN tend to maximize reversals and parallelisms, respectively (Swofford and Maddison 1987; Maddison and Maddison 2000).

#### RESULTS

##### *Spikelet Sexuality*

The results of the ACCTRAN and DELTRAN character state reconstructions for spikelet sexuality are shown in Fig. 1 and 2 (arrows). In the ACCTRAN optimization (Fig. 1), the absence of unisexual spikelets (i.e., all spikelets hermaphrodite, plants monoclinal) is ancestral in *Bouteloua*, and there are three origins of unisexuality (solid arrows) and four reversals to monoecy (dashed arrows). However, in the DELTRAN optimization (Fig. 2), the two most ancestral nodes in *Bouteloua* are equivocal for spikelet sexuality (not shown), which yields two quite different interpretations: seven origins of dicliny (solid arrows) and no reversals, or two origins of monoecy (white-tipped arrows) and six reversals to dicliny (thin arrows).

In the ACCTRAN reconstruction (Fig. 1), there is an origin of spikelet unisexuality in the lineage leading to *Bouteloua stolonifera*. This is also the case under DELTRAN (Fig. 2, thick arrow) if the two most ancestral nodes in the genus are interpreted to be monoclinal. However, if these nodes are interpreted to be diclinous, then unisexual spikelets are plesiomorphic. The ACCTRAN optimization shows another origin of dicliny in the common ancestor of *B. bracteata*, *B. chondrosioides*, and *B. dimorpha* (hereafter referred to as clade I) followed by a reversal in the monoclinal form of *B. chondrosioides*. In contrast, DELTRAN optimizes the common ancestor as monoclinal and unisexual spikelets as having arisen twice, in the *B. bracteata-B. dimorpha* and *B. chondrosioides* lineages, respectively. The ACCTRAN and DELTRAN optimizations also differ with respect to a large clade comprising *B. nervata*, *B. reederorum*, and *B. rigidisetata* (Steud.) Hitchc. (clade II) plus *B. dactyloides*, *B. diversispicula*, *B. eludens* Griffiths, *B. mexicana*, *B. multifida*, and *B. scabra* (Kunth) Columbus (clade III). Under ACCTRAN, unisexual spikelets evolve in the common ancestor of this large clade followed by three reversals in *B. eludens*, *B. rigidisetata*, and *B. scabra*, respectively. Under DELTRAN,

the common ancestor is monoclinous and unisexual spikelets arise four times, in the lineages leading to *B. dactyloides*, *B. diversispicula*–*B. multifida*, *B. mexicana*, and *B. nervata*–*B. reederorum*.

### Breeding System

The ACCTTRAN and DELTRAN character state reconstructions for breeding system are shown in Fig. 1 and 2, and the results are summarized in Table 2. In both optimizations, monocliny is ancestral in *Bouteloua*, and there is one transition to dioecy in the lineage leading to *B. stolonifera*. The optimizations are likewise concordant with regard to clade I, wherein gynodioecy in *B. chondrosioides* is derived from monocliny, and the ancestral state in the *B. bracteata*–*B. dimorpha* clade is equivocal for monoecy and dioecy. Also, in both optimizations there is one transition from monocliny to dioecy in clade II, followed by a shift to monoecy in *B. reederorum*. However, the ACCTTRAN and DELTRAN optimizations differ with respect to clade III. Under ACCTTRAN, monoecy arises from monocliny and is the ancestral state in the clade. Three subsequent transitions to dioecy are inferred in *B. dactyloides*, *B. diversispicula*, and *B. mexicana*, as well as a shift to andromonoecy in *B. multifida*. Under DELTRAN, monocliny is ancestral in the clade. There are three transitions to monoecy in *B. dactyloides*, *B. mexicana*, and the ancestral branch of the *B. diversispicula*–*B. multifida* clade, respectively. Transitions from monoecy to dioecy are also implicated in both *B. dactyloides* and *B. mexicana*. In *B. diversispicula* and *B. multifida* there are shifts from monoecy to dioecy and andromonoecy, respectively.

## DISCUSSION

### Ancestral Condition

Although most of the 57 *Bouteloua* species have only hermaphrodite spikelets, there is uncertainty about the ancestral condition in the genus because one early diverging species, *B. stolonifera*, is dioecious, and some related genera are diclinous. Unfortunately, the sister group of *Bouteloua* is presently unknown, which presents a significant obstacle to resolving the ancestral state. Correct outgroup selection is critical in determining ancestral character states in a lineage (Donoghue and Cantino 1984; Maddison et al. 1984). In a phylogenetic study of Chloridoideae based on *trnL*–*F* and ITS sequences (Columbus et al. 2007), low resolution and support in the Cynodonteae clade leaves many taxa as candidate sister taxa of *Bouteloua*. Although most chloridoids are monoclinous, a number of genera near *Bouteloua* in the *trnL*–*F* and combined *trnL*–*F*/ITS strict consensus trees (the ITS strict consensus tree is less resolved with respect to Cynodonteae) are dioecious, including *Distichlis* Raf. and *Sohnsia* Airy Shaw, a breeding system not represented in the outgroup taxa in Columbus et al. (2000), the source of the tree used in the present study. Of the two andromonoecious genera employed here in the outgroup, *Aegopogon* Humb. & Bonpl. ex Willd. and *Pleuraphis* Torr., the former can be confidently eliminated as sister to *Bouteloua* because it is nested within the *Muhlenbergia* Schreb. clade (Columbus et al. 2007).

With the outgroup taxa included here, and employing both

a two-state spikelet sexuality character and a five-state breeding system character, the common ancestor of *Bouteloua* is inferred to have been monoclinous, having only hermaphrodite spikelets, except under the DELTRAN optimization of spikelet sexuality, which results in equivocacy at the ancestral node. To explore the influence of the outgroup on these reconstructions, we assigned different character states to the outgroup. Under ACCTTRAN, monocliny remains ancestral even if all six outgroup taxa are coded as having unisexual spikelets and possessing any of the diclinous breeding systems, including dioecy. Under DELTRAN, however, which delays transformations away from the root (Swofford and Maddison 1987; Maddison and Maddison 2000), the outgroup has much greater influence on the ingroup. When either *Aegopogon* or *Pleuraphis* is coded as lacking unisexual spikelets, this becomes the ancestral state in *Bouteloua*. When *Tragus* Haller or any pair of *Chloris* Sw., *Cynodon* Rich., and *Microchloa* R. Br. are coded as having unisexual spikelets, the common ancestor of *Bouteloua* is inferred to have had unisexual spikelets. However, with respect to breeding system, a switch from monocliny to dicliny (dioecy) in the ancestral node requires *Aegopogon*, *Pleuraphis*, and *Tragus* all to be coded as dioecious. Of note, none of the manipulations in outgroup coding affected the pattern of character state reconstructions in the tree beyond the two most ancestral nodes.

Thus, based on the combined ITS/*trnL*–*F* tree used in this study and different models of character evolution, it seems likely the common ancestor of *Bouteloua* was monoclinous. However, if the closest relatives of *Bouteloua* are dioecious, which is certainly possible based on Columbus et al. (2007), then the genus could be ancestrally dioecious.

### Spikelet Sexuality and Breeding System Shifts

The results show up to seven origins of unisexual spikelets in *Bouteloua* depending on the optimization criterion employed and the character state assigned to the two most ancestral nodes. These nodes are equivocal under DELTRAN; if interpreted to be diclinous, the presence of unisexual spikelets in *B. stolonifera* represents a plesiomorphy, not an independent origin. As well, it must be pointed out that the relationships among clades I, II, and III, although each clade is statistically supported, remain uncertain, as is evidenced by low bootstrap values in the larger clades (Fig. 1). If clade I is repositioned to be the sister of clade II/III, only a single origin of unisexual spikelets is inferred under both ACCTTRAN and DELTRAN, although the breeding system transitions do not change in either optimization. As implemented in PAUP\* (Swofford 2002), constraining clade I/II/III to be monophyletic yields three trees of length 2005, four steps longer than the unconstrained trees, a difference that is not significant based on the Templeton (1983;  $P = 0.4142$ – $0.5371$ ) and Kishino and Hasegawa (1989;  $P = 0.4144$ – $0.5372$ ) tests (however, if *B. stolonifera* and clade I/II/III are constrained to be monophyletic, tree length increases by 22 steps, a difference that is significant [ $P = 0.0038$ – $0.0128$ , which includes the ranges for both tests]). Therefore, under these possible scenarios, unisexual spikelets could have originated only once in *Bouteloua*.

Under ACCTTRAN (Fig. 1), there are four reversals

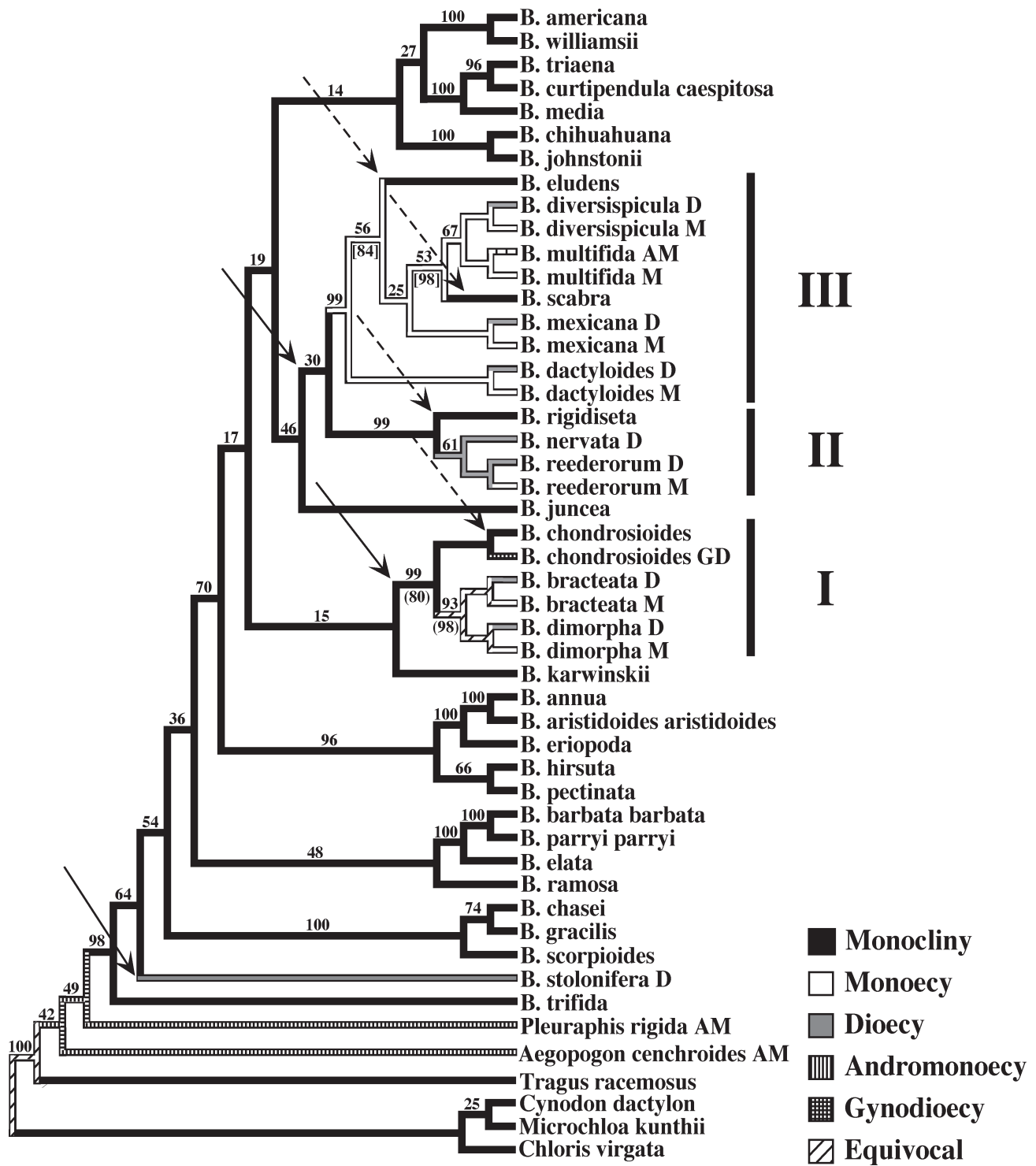

Fig. 1.—ACCTRAN character state reconstructions for spikelet sexuality and breeding system in *Bouteloua*. One of six trees resulting from parsimony analysis of combined ITS and *trnL-F* sequences (Columbus et al. 2000). Bootstrap percentages are above branches. Below branches in parentheses and brackets, respectively, are selected bootstrap percentages from individual analyses of ITS and *trnL-F* (Columbus et al. 2000). Solid arrows indicate transitions to spikelet unisexuality and dashed arrows indicate reversals to hermaphroditism. M = monoecious, D = dioecious, AM = andromonoecious, GD = gynodioecious.

(dashed arrows) from unisexual to hermaphrodite spikelets, whereas under DELTRAN (Fig. 2) there are zero or two (white-tipped arrows), depending on whether the ancestral two nodes in *Bouteloua* are interpreted as diclinous or mono-

clinous, respectively. For spikelet unisexuality, the ACCTRAN hypothesis for character evolution is perhaps less likely than DELTRAN, because such reversals to hermaphroditism would require gain-of-function mutations, which



Fig. 2.—DELTRAN character state reconstructions for spikelet sexuality and breeding system in *Bouteloua*. See Fig. 1 caption for further explanation except with regard to the arrows, which are explained in the text.

are thought to be infrequent in nature (Bull and Charnov 1985). Transitions from floral unisexuality to hermaphroditism are proposed to occur in angiosperms, but these theoretically would take place early in the evolution of dioecy when hermaphrodite individuals are still in a population (Lloyd 1975; Weller et al. 1995). For example, a population could revert completely back to monoecy early in the es-

tablishment of gynodioecy when there are few females and selection for hermaphrodites is strong (Lloyd 1975; Charlesworth and Charlesworth 1978; Weller et al. 1995). Transitions from gynodioecy to monoecy have been implicated in species of *Schiedea* (Weller et al. 1995; Norman et al. 1997).

In the lineage leading to *Bouteloua stolonifera*, the

Table 2. Summary of breeding system transitions in *Bouteloua* based on ACCTRAN (Fig. 1) and DELTRAN (Fig. 2) character state reconstructions. Number of possible additional transitions (i.e., nodes equivocal for multiple states) in parentheses.

Transition	ACCTRAN	DELTRAN
Monocliny → Monoecy	1 (1)	3 (1)
Monocliny → Dioecy	2 (1)	4 (1)
Monocliny → Gynodioecy	1	1
Monoecy → Dioecy	3 (2)	1 (2)
Monoecy → Andromonoecy	1	1
Monoecy → Monocliny	2	0
Dioecy → Monoecy	1 (2)	1 (2)

ACCTRAN reconstruction (Fig. 1) shows one transition from hermaphroditism to spikelet unisexuality. However, under DELTRAN (Fig. 2), dicliny in this species could represent a plesiomorphy instead of an apomorphy, which, correspondingly, means monocliny in *B. trifida* Thurb. would represent a reversal from dicliny. The evidence—*Bouteloua* likely is ancestrally monoclinous and transitions from unisexuality to hermaphroditism are unlikely (Bull and Charnov 1985)—supports an independent origin of unisexual spikelets and dioecy in *B. stolonifera*.

In clade I, the ACCTRAN reconstruction (Fig. 1, arrows) shows one origin of spikelet unisexuality in the common ancestor and one reversal to hermaphroditism in *Bouteloua chondrosioides*. In the DELTRAN reconstruction (Fig. 2, arrows), there are two origins of spikelet unisexuality, one in the common ancestor of *B. bracteata* and *B. dimorpha*, each of which can be monoecious or dioecious, and the other in *B. chondrosioides*, in which monocliny and gynodioecy both occur. The DELTRAN optimization of spikelet sexuality is consistent with both the ACCTRAN and DELTRAN breeding system reconstructions (Fig. 1, 2), which are identical and also show two origins of dicliny. Two origins appear more likely than one because the latter scenario involves a theoretically improbable reversal to monocliny in *B. chondrosioides*. As well, gynodioecy, here likely derived from monocliny, is theorized to be the result of distinct genetic mechanisms, and it is thought that this breeding system often leads to the establishment of dioecy (Lloyd 1975, 1976; Charlesworth and Charlesworth 1978; Charlesworth 1989; Maurice et al. 1993), although there is no evidence for this in the present study. There is probably a different genetic mechanism for unisexual flower formation in the monoecious/dioecious *B. bracteata* and *B. dimorpha* than in the gynodioecious populations of *B. chondrosioides*.

In all phylogenetic analyses of *Bouteloua*, there is statistical support for clade I (Columbus et al. 1998, 2000). However, as mentioned above, the ITS and *trnL*-F phylogenies are incongruent with respect to relationships within the clade. *Bouteloua bracteata* and *B. dimorpha* are sister in the ITS and combined ITS/*trnL*-F phylogenies (Fig. 1), whereas *B. bracteata* and *B. chondrosioides* are sister in the *trnL*-F phylogeny (Fig. 3); the relationships are statistically supported in each phylogeny (Columbus et al. 1998, 2000). To explore the effect of this difference on character state reconstruction, the spikelet sexuality and breeding system character states were optimized on the *trnL*-F phylogeny using

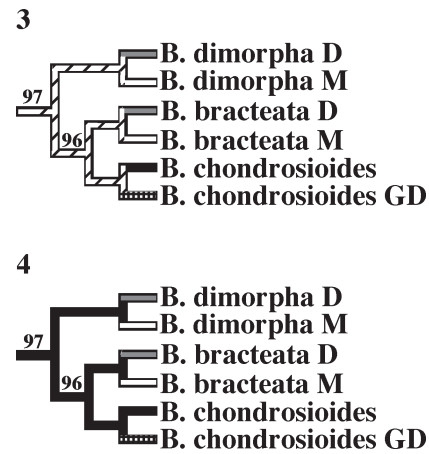

Fig. 3–4.—Character state reconstructions for breeding system in clade I species, the relationships based on parsimony analysis of *trnL*-F sequences (Columbus et al. 2000). See Fig. 1 caption for further explanation.—3. ACCTRAN.—4. DELTRAN.

ACCTRAN and DELTRAN. Both reconstructions of spikelet sexuality (not shown) infer a single origin of dicliny in the common ancestor of clade I, which is consistent with the ACCTRAN optimization on the combined phylogeny (Fig. 1), but, as mentioned above, this scenario is doubtful. Optimizing the breeding system character states on the *trnL*-F phylogeny results in different scenarios under ACCTRAN and DELTRAN and as compared to the combined topology. In the ACCTRAN reconstruction (Fig. 3) all nodes are equivocal (four of the five for monoecy/dioecy), whereas under DELTRAN (Fig. 4) all nodes are monoclinous, which means none of the diclinous breeding systems in the clade (monoecy, dioecy, gynodioecy) gives rise to another, even within species. Both of these reconstructions are unlikely. As discussed above, a reversal to monocliny (in *B. chondrosioides*) from dicliny (Fig. 3) is improbable, and independent origins of monoecy and dioecy in both *B. bracteata* and *B. dimorpha* (Fig. 4) are likewise doubtful. The hypotheses of relationship and character state transitions shown in Fig. 1 and 2, a combined ITS/*trnL*-F tree (congruent with the ITS tree), are more plausible. Under both ACCTRAN (Fig. 1) and DELTRAN (Fig. 2), there is a single origin of monoecy or dioecy in the common ancestor of *B. bracteata* and *B. dimorpha*, species that are morphologically more similar to one another than either is to *B. chondrosioides*.

Relationships between and within clades II and III lack statistical support in the analysis of the combined ITS/*trnL*-F data, although each clade is supported by a 99% bootstrap value (Fig. 1; Columbus et al. 2000). The six most parsimonious trees from this analysis (only one selected for our study) differ only with respect to relationships within clade III and in the position of *Bouteloua juncea* (Desv. ex P. Beauv.) Hitchc. However, bootstrapping the *trnL*-F data alone yielded 84% support for the clade excluding *B. dactyloides* and 98% support for the clade comprising *B. diversispicula*, *B. multifida*, and *B. scabra* (Fig. 1). No other clades received support in independent analyses of the two data sets (Columbus et al. 2000). The lack of support and therefore certainty about many of the relationships limits what can be concluded regarding character evolution. Fur-



thermore, the ACCTTRAN (Fig. 1) and DELTRAN (Fig. 2) optimizations of both reproductive characters (spikelet sexuality and breeding system) yield different hypotheses with respect to clade III, with one and three origins of dioecy, respectively. If one believes reversals from dioecy to monoecy are improbable, the DELTRAN hypothesis (Fig. 2) would be favored, although, unlike ACCTTRAN (Fig. 1), this scenario involves the independent origin of monoecy and dioecy in *B. dactyloides* and *B. mexicana*. Another uncertainty involves *B. scabra*, coded as monoecious in this study. Its spikelets are unquestionably hermaphrodite, but the species in fact may be andromonoecious. Most species of *Bouteloua* have only one flower per spikelet, which develops in the proximal floret, and accompanying florets, usually present, are typically sterile. In *B. scabra*, the proximal floret is hermaphrodite, but well-developed stamens have been observed in the second floret. Gould (1969) and Columbus et al. (1998) mentioned the occurrence of such staminate florets in species of the *B. repens* (Kunth) Scribn. complex (represented by *B. americana* (L.) Scribn. and *B. williamsii* Swallen in the present study) and *Pentarrhaphis* Kunth (= *Bouteloua*; represented here by *B. scabra*), respectively. If *B. scabra* is coded as andromonoecious, it represents another origin of this breeding system within *Bouteloua* (also in *B. multifida*) under both ACCTTRAN and DELTRAN (not shown) and, under DELTRAN, it causes the character state in the common ancestor of the least inclusive clade containing *B. diversispicula* and *B. mexicana* to change from monoecious to monoecious. Andromonoecy is thought to have evolved from monoecy as a means to optimize sexual resource allocation (Bertin 1982; Podolsky 1992; Brunet and Charlesworth 1995). It also has been implicated as an intermediate stage in the evolution of dioecy. In Australian *Solanum* L., there are several closely related andromonoecious and dioecious species, and phylogenetic research indicates that dioecy likely evolved from andromonoecy in this group (Martine et al. 2006). However, our reconstructions show andromonoecy arising from monoecy in *Bouteloua* (Fig. 1, 2).

Based on the combined ITS/*trnL*-F phylogeny (Columbus et al. 2000) and the various scenarios of character evolution we have explored, our analysis suggests the common ancestor of *Bouteloua* possessed only hermaphrodite flowers, and unisexual spikelets evolved multiple times in parallel. This supports Columbus et al. (1998, 2000), who suggested that the group is predisposed to the evolution of unisexual spikelets. Polyploidy, proposed to play a role in the evolution of floral unisexuality in several plant groups (Miller and Venable 2000), has been reported in seven dioecious species of *Bouteloua*, six of which exhibit dioecy (Table 1). Polyploidization is thought to break down self-incompatibility mechanisms in angiosperms (Richards 1997; de Nettancourt 2001). In theory, this could provide the driving force for the evolution of unisexual flowers as a means to avoid ensuing inbreeding depression. For this mechanism to work in *Bouteloua*, self-incompatibility would have had to occur in the lineages leading to dioecious species. Monoecious plants of *B. dactyloides* have been found to be self-compatible (East 1940; Quinn 1991), but a comprehensive study and review of compatibility in *Bouteloua* are lacking and needed. Also, diploidy has been reported in *B. chondrosioides*, *B. dacty-*

*loides*, and *B. multifida* (Table 1), and many monoecious species in the genus are polyploid (Gould 1980).

The occurrence of unisexual flowers in many plant groups is correlated with wind pollination and dry habitats (Bawa 1980; Givnish 1980; Hart 1985; Renner and Ricklefs 1995; Weller et al. 1995). Excluding some cleistogamy, most species of *Bouteloua*, as well as most Poaceae (Connor 1987), are wind pollinated. In addition, all species of *Bouteloua* occur in areas, including deserts, characterized by relatively high temperatures and low precipitation (Columbus et al. 1998). Plants that occur in harsh environments often display great variability in breeding systems and reproductive strategy (Quinn 1998), and *Bouteloua* illustrates this well.

#### Evolution of Dioecy

In this study two breeding systems, monoecy and monoecy, are implicated as progenitors of dioecy in *Bouteloua*, whereas andromonoecy and gynodioecy are not. In the combined ITS/*trnL*-F phylogeny, both ACCTTRAN (Fig. 1) and DELTRAN (Fig. 2) character state reconstructions show shifts directly from monoecy to dioecy in the lineage leading to *B. stolonifera* and in clade II. In the DELTRAN optimization (Fig. 2), there are also shifts to dioecy from monoecy in *B. dactyloides* and *B. mexicana*. Employing the *trnL*-F phylogeny and DELTRAN, direct transitions from monoecy are shown in both *B. bracteata* and *B. dimorpha* (Fig. 4). Transitions from monoecy to dioecy are limited to clade III in our analyses, where there are three shifts under ACCTTRAN (Fig. 1) and one shift under DELTRAN (Fig. 2), with a transition in *B. diversispicula* common to both optimizations.

Weiblen et al. (2000), in a phylogenetic analysis of dioecy in monocotyledons, determined that transitions from monoecy to dioecy occurred more often than shifts from monoecy to dioecy. However, the pathway from monoecy to dioecy theoretically would entail a minimum of two separate mutations to impart male and female sterility (Lewis 1942). Therefore, the transition probably would involve dioecious intermediates that may now be extinct. Transitions from monoecy to dioecy are implicated in a number of plant groups (Yampolsky and Yampolsky 1922; Lewis 1942; Westergaard 1958; Lloyd 1972; McArthur et al. 1992; Renner and Ricklefs 1995). After monoecy is established, one or more mutations altering the ratio of male and female flowers on individual plants could lead to dioecy (Lloyd 1972; McArthur et al. 1992).

With the exception of *Bouteloua nervata* and *B. stolonifera*, which appear to be obligately dioecious, monoecious plants have been reported in the six other species of *Bouteloua* exhibiting dioecy (Columbus et al. 1998, 2000). The frequency of monoecy in these species (i.e., populations with both monoecious and unisexual individuals) varies from infrequent in *B. diversispicula* (Pierce 1979) to predominant in *B. bracteata* and *B. reederorum*. In clade III, monoecy is ancestral to dioecy in *B. diversispicula* in both modes of character state reconstruction (Fig. 1, 2). This is also the case for *B. dactyloides* and *B. mexicana* under ACCTTRAN (Fig. 1), but not under DELTRAN (Fig. 2), where monoecy and dioecy are independently derived from monoecy in each species, a scenario we deem unlikely. In clade I, the common

ancestor of *B. bracteata* and *B. dimorpha* is equivocal for monoecy and dioecy in both optimizations (Fig. 1, 2). It is likely that dioecy evolved from monoecy in these two species, although the possibility of a shift from dioecy to monoecy, as seen in *B. reederorum* in clade II, must also be considered. Lloyd (1975) suggested that monoecy could have evolved from dioecy in *Cotula* L. (Asteraceae). This was proposed to occur due to selection for male and female function in populations that consisted solely of male plants where some males were able to produce a few female flowers.

In sum, of the diclinous breeding systems examined in this study, only monoecy is implicated as a possible intermediate in the evolution of dioecy in *Bouteloua*.

#### FUTURE RESEARCH

A deeper understanding of the evolution of floral unisexuality and breeding systems in *Bouteloua* likely would be gained through greater phylogenetic resolution and support. Many relationships in the ITS and *trnL*-F phylogenies remain uncertain, whether the data sets are analyzed separately or in combination (Columbus et al. 1998, 2000), which limits inferences about character evolution. Additional sequence data from the chloroplast and nuclear genomes, as well as additional methods of data analysis (e.g., maximum likelihood), are needed in an effort to achieve more robust phylogenetic estimates. Greater taxon sampling is desirable, too. At a minimum, the diclinous species not included in the present study need to be added, but ideally all species of *Bouteloua* would be sampled. As well, additional data are needed to further resolve relationships in Cynodonteae, in part to determine the sister group of *Bouteloua* and the phylogenetic positions of the other diclinous taxa. Finally, breeding system variation in *Bouteloua* requires greater study. For instance, spikelets in *B. scabra* and other species appear to have a functional staminate floret along with the hermaphrodite floret. The occurrence (including lability) and contribution of these apparently sexually functional florets needs to be determined.

#### ACKNOWLEDGMENTS

Special thanks to Mark Porter for insight and helpful discussion, and to Lucinda McDade for her critical review. We are grateful to Nancy Refulio, Hester Bell, and Lucinda McDade for assistance in implementing the Templeton (1983) and Kishino and Hasegawa (1989) tests. Also, thanks to the staff and students at Rancho Santa Ana Botanic Garden. This work was supported by grants to MSK from the A. W. Mellon Foundation, the C. L. Smith Botany Award, the Hardman Award for Native Plant Research, the Goldhamer Award, and the RSABG Alumni Foundation.

#### LITERATURE CITED

- BAKER, H. G. 1984. Some functions of dioecy in seed plants. *Amer. Naturalist* **124**: 149–158.
- BAWA, K. S. 1980. Evolution of dioecy in flowering plants. *Annual Rev. Ecol. Syst.* **11**: 15–39.
- BERTIN, R. I. 1982. The evolution and maintenance of andromonoecy. *Evol. Theory* **6**: 25–32.
- BRUNET, J., AND D. CHARLESWORTH. 1995. Floral sex allocation in sequentially blooming plants. *Evolution* **49**: 70–79.
- BULL, J. J., AND E. L. CHARNOV. 1985. On irreversible evolution. *Evolution* **39**: 1149–1155.
- CHARLESWORTH, D. 1989. Allocation to male and female function in hermaphrodites, in sexually polymorphic populations. *J. Theor. Biol.* **139**: 327–342.
- , AND B. CHARLESWORTH. 1978. A model for the evolution of dioecy and gynodioecy. *Amer. Naturalist* **112**: 975–997.
- , AND ———. 1981. Allocation of resources to male and female function in hermaphrodites. *Biol. J. Linn. Soc.* **15**: 57–74.
- COLUMBUS, J. T. 1999. An expanded circumscription of *Bouteloua* (Gramineae: Chloridoideae): new combinations and names. *Aliso* **18**: 61–65.
- , R. CERROS-TLATILPA, M. S. KINNEY, M. E. SIQUEIROS-DELGADO, H. L. BELL, M. P. GRIFFITH, AND N. F. REFULIO-RODRIGUEZ. 2007. Phylogenetics of Chloridoideae (Gramineae): a preliminary study based on nuclear ribosomal internal transcribed spacer and chloroplast *trnL*-F sequences, pp. 565–579. In J. T. Columbus, E. A. Friar, J. M. Porter, L. M. Prince, and M. G. Simpson [eds.], *Monocots: Comparative biology and evolution—Poales*. Rancho Santa Ana Botanic Garden, Claremont, California, USA.
- , M. S. KINNEY, R. PANT, AND M. E. SIQUEIROS DELGADO. 1998. Cladistic parsimony analysis of internal transcribed spacer region (nrDNA) sequences of *Bouteloua* and relatives (Gramineae: Chloridoideae). *Aliso* **17**: 99–130.
- , ———, M. E. SIQUEIROS DELGADO, AND J. M. PORTER. 2000. Phylogenetics of *Bouteloua* and relatives (Gramineae: Chloridoideae): cladistic parsimony analysis of internal transcribed spacer (nrDNA) and *trnL*-F (cpDNA) sequences, pp. 189–194. In S. W. L. Jacobs and J. Everett [eds.], *Grasses: systematics and evolution*. CSIRO Publishing, Collingwood, Victoria, Australia.
- CONNOR, H. E. 1987. Reproductive biology in the grasses, pp. 117–132. In T. R. Soderstrom, K. W. Hilu, C. S. Campbell, and M. E. Barkworth [eds.], *Grass systematics and evolution*. Smithsonian Institution Press, Washington, D.C., USA.
- DARWIN, C. 1876. The effects of cross and self fertilisation in the vegetable kingdom. John Murray, London, UK. 482 p.
- . 1877. The different forms of flowers on plants of the same species. John Murray, London, UK. 352 p.
- DE NETTANCOURT, D. 2001. Incompatibility and incongruity in wild and cultivated plants. Springer, New York, USA. 322 p.
- DE QUEIROZ, K. 2000. Logical problems associated with including and excluding characters during tree reconstruction and their implications for the study of morphological character evolution, pp. 192–212. In J. J. Wiens [ed.], *Phylogenetic analysis of morphological data*. Smithsonian Institution Press, Washington, D.C., USA.
- DONOGHUE, M. J., AND P. D. CANTINO. 1984. The logic and limitations of the outgroup substitution approach to cladistic analysis. *Syst. Bot.* **9**: 192–202.
- EAST, E. M. 1940. The distribution of self-sterility in the flowering plants. *Proc. Amer. Philos. Soc.* **82**: 449–518.
- GIVNISH, T. J. 1980. Ecological constraints on the evolution of breeding systems in seed plants: dioecy and dispersal in gymnosperms. *Evolution* **34**: 959–972.
- . 1982. Outcrossing versus ecological constraints in the evolution of dioecy. *Amer. Naturalist* **119**: 849–865.
- GOULD, F. W. 1966. Chromosome numbers of some Mexican grasses. *Canad. J. Bot.* **44**: 1683–1696.
- . 1968. Chromosome numbers of Texas grasses. *Canad. J. Bot.* **46**: 1315–1325.
- . 1969. Taxonomy of the *Bouteloua repens* complex. *Brittonia* **21**: 261–274.
- . 1979 [1980]. The genus *Bouteloua* (Poaceae). *Ann. Missouri Bot. Gard.* **66**: 348–416.

- GOUYON, P.-H., F. VICHOT, AND J. M. M. VAN DAMME. 1991. Nuclear-cytoplasmic male sterility: single-point equilibria versus limit cycles. *Amer. Naturalist* **137**: 498–514.
- HART, J. A. 1985. Evolution of dioecism in *Lepechinia* Willd. sect. *Parviflorae* (Lamiaceae). *Syst. Bot.* **10**: 147–154.
- HILLIS, D. M., AND J. J. BULL. 1993. An empirical test of bootstrapping as a method for assessing confidence in phylogenetic analysis. *Syst. Biol.* **42**: 182–192.
- JACKSON, B. D. 1928. A glossary of botanic terms with their derivation and accent, Ed. 4. Gerald Duckworth and Co., London, UK. 481 p.
- KISHINO, H., AND M. HASEGAWA. 1989. Evaluation of the maximum likelihood estimate of the evolutionary tree topologies from DNA sequence data, and the branching order in Hominoidea. *J. Molec. Evol.* **29**: 170–179.
- LEWIS, D. 1942. The evolution of sex in flowering plants. *Biol. Rev. Cambridge Philos. Soc.* **17**: 46–67.
- LINCOLN, R. J., G. A. BOXSHALL, AND P. F. CLARK. 1998. A dictionary of ecology, evolution and systematics, Ed. 2. Cambridge University Press, Cambridge, UK. 361 p.
- LOYD, D. G. 1972. Breeding systems in *Cotula* L. (Compositae, Anthemideae). I. The array of monoclinal and diclinous systems. *New Phytol.* **71**: 1181–1194.
- . 1975. Breeding systems in *Cotula*. IV. Reversion from dioecy to monoecy. *New Phytol.* **74**: 125–145.
- . 1976. The transmission of genes via pollen and ovules in gynodioecious angiosperms. *Theor. Populat. Biol.* **9**: 299–316.
- . 1982. Selection of combined versus separate sexes in seed plants. *Amer. Naturalist* **120**: 571–585.
- LÖVE, A., AND D. LÖVE. 1981. In Chromosome number reports LXX. *Taxon* **30**: 72.
- MADDISON, D. R., AND W. P. MADDISON. 2000. MacClade 4: analysis of phylogeny and character evolution, vers. 4.0. Sinauer Associates, Sunderland, Massachusetts, USA.
- MADDISON, W. P., M. J. DONOGHUE, AND D. R. MADDISON. 1984. Outgroup analysis and parsimony. *Syst. Zool.* **33**: 83–103.
- MARTINE, C. T., D. VANDERPOOL, G. J. ANDERSON, AND D. H. LES. 2006. Phylogenetic relationships of andromonoecious and dioecious Australian species of *Solanum* subgenus *Leptostemonum* section *Melongena*: inferences from ITS sequence data. *Syst. Bot.* **31**: 410–420.
- MAURICE, S., D. CHARLESWORTH, C. DESFEUX, D. COUVET, AND P.-H. GOUYON. 1993. The evolution of gender in hermaphrodites of gynodioecious populations with nucleocytoplasmic male-sterility. *Proc. Roy. Soc. Biol. Sci. Ser. B* **251**: 253–261.
- MCCARTHER, E. D., D. C. FREEMAN, L. S. LUCKINBILL, S. C. SANDERSON, AND G. L. NOLLER. 1992. Are trioecy and sexual lability in *Atriplex canescens* genetically based? Evidence from clonal studies. *Evolution* **46**: 1708–1721.
- MILLER, J. S., AND D. L. VENABLE. 2000. Polyploidy and the evolution of gender dimorphism in plants. *Science* **289**: 2335–2338.
- NIELSEN, E. L. 1939. Grass studies. III. Additional somatic chromosome complements. *Amer. J. Bot.* **26**: 366–372.
- NIXON, K. C., AND J. I. DAVIS. 1991. Polymorphic taxa, missing values and cladistic analysis. *Cladistics* **7**: 233–241.
- NORMAN, J. K., S. G. WELLER, AND A. K. SAKAI. 1997. Pollination biology and outcrossing rates in hermaphroditic *Schiedea lydgatei* (Caryophyllaceae). *Amer. J. Bot.* **84**: 641–648.
- PIERCE, G. J. 1978. *Griffithsochloa*, a new genus segregated from *Cathestecum* (Gramineae). *Bull. Torrey Bot. Club* **105**: 134–138.
- . 1979. A biosystematic study of *Cathestecum* and *Griffithsochloa* (Gramineae). Ph.D. dissertation, University of Wyoming, Laramie, USA.
- PODOLSKY, R. D. 1992. Strange floral attractors: pollinator attraction and the evolution of plant sexual systems. *Science* **258**: 791–793.
- QUINN, J. A. 1991. Evolution of dioecy in *Buchloe dactyloides* (Gramineae): tests for sex-specific vegetative characters, ecological differences, and sexual niche-partitioning. *Amer. J. Bot.* **78**: 481–488.
- . 1998. Ecological aspects of sex expression in grasses, pp. 136–154. In G. P. Cheplick [ed.], Population biology of grasses. Cambridge University Press, Cambridge, UK.
- REEDER, J. R. 1967. Notes on Mexican grasses VI. Miscellaneous chromosome numbers. *Bull. Torrey Bot. Club* **94**: 1–17.
- . 1968. Notes on Mexican grasses VIII. Miscellaneous chromosome numbers—2. *Bull. Torrey Bot. Club* **95**: 69–86.
- . 1969. Las gramíneas dioicas de México. *Bol. Soc. Bot. México* **30**: 121–126.
- . 1971. Notes on Mexican grasses IX. Miscellaneous chromosome numbers—3. *Brittonia* **23**: 105–117.
- . 1984. In Chromosome number reports LXXXII. *Taxon* **33**: 132–133.
- , AND C. G. REEDER. 1966. Notes on Mexican grasses IV. Dioecy in *Bouteloua chondrosioides*. *Brittonia* **18**: 188–191.
- RENNER, S. S., AND R. E. RICKLEFS. 1995. Dioecy and its correlates in the flowering plants. *Amer. J. Bot.* **82**: 596–606.
- RICHARDS, A. J. 1997. Plant breeding systems, Ed. 2. Chapman and Hall, London, UK. 529 p.
- RIESEBERG, L. H., M. A. HANSON, AND C. T. PHILBRICK. 1992. Androdioecy is derived from dioecy in Datisceae: evidence from restriction site mapping of PCR-amplified chloroplast DNA fragments. *Syst. Bot.* **17**: 324–336.
- ROSS, M. D. 1970. Evolution of dioecy from gynodioecy. *Evolution* **24**: 827–828.
- . 1982. Five evolutionary pathways to subdioecy. *Amer. Naturalist* **119**: 297–318.
- , AND B. S. WEIR. 1976. Maintenance of males and females in hermaphrodite populations and the evolution of dioecy. *Evolution* **30**: 425–441.
- SWOFFORD, D. L. 2002. PAUP\*: phylogenetic analysis using parsimony (\*and other methods), vers. 4.0. Sinauer Associates, Sunderland, Massachusetts, USA.
- , AND W. P. MADDISON. 1987. Reconstructing ancestral character states under Wagner parsimony. *Math. Biosci.* **87**: 199–229.
- TEMPLETON, A. R. 1983. Phylogenetic inference from restriction endonuclease cleavage site maps with particular reference to the evolution of humans and apes. *Evolution* **37**: 221–244.
- THOMSON, J. D., AND S. C. H. BARRETT. 1981. Selection for outcrossing, sexual selection, and the evolution of dioecy in plants. *Amer. Naturalist* **118**: 443–449.
- VAN DER PIJL, L. 1978. Reproductive integration and sexual disharmony in floral functions, pp. 79–88. In A. J. Richards [ed.], The pollination of flowers by insects. Academic Press, London, UK.
- WEIBLEN, G. D., R. K. OYAMA, AND M. J. DONOGHUE. 2000. Phylogenetic analysis of dioecy in monocotyledons. *Amer. Naturalist* **155**: 46–58.
- WELLER, S. G., AND A. K. SAKAI. 1999. Using phylogenetic approaches for the analysis of plant breeding system evolution. *Annual Rev. Ecol. Syst.* **30**: 167–199.
- , W. L. WAGNER, AND A. K. SAKAI. 1995. A phylogenetic analysis of *Schiedea* and *Alsinidendron* (Caryophyllaceae: Alsinoideae): implications for the evolution of breeding systems. *Syst. Bot.* **20**: 315–337.
- WESTERGAARD, M. 1958. The mechanism of sex determination in dioecious flowering plants. *Advances Genet.* **9**: 217–281.
- WILLSON, M. F. 1982. Sexual selection and declining in angiosperms. *Amer. Naturalist* **119**: 579–583.
- YAMPOLSKY, C., AND H. YAMPOLSKY. 1922. Distribution of sex forms in the phanerogamic flora. *Biblioth. Genet.* **3**: 1–62.