

UNIV. of ARIZONA  
The rotary-vane attenuator as an interlab  
C 13.44: 144

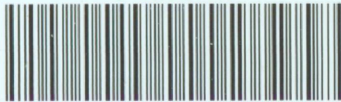

3 9001 90000 9658



NBS MONOGRAPH 141

U.S. DEPARTMENT OF COMMERCE / National Bureau of Standards

# THE MEASUREMENT OF LUMPED PARAMETER IMPEDANCE:

## A METROLOGY GUIDE

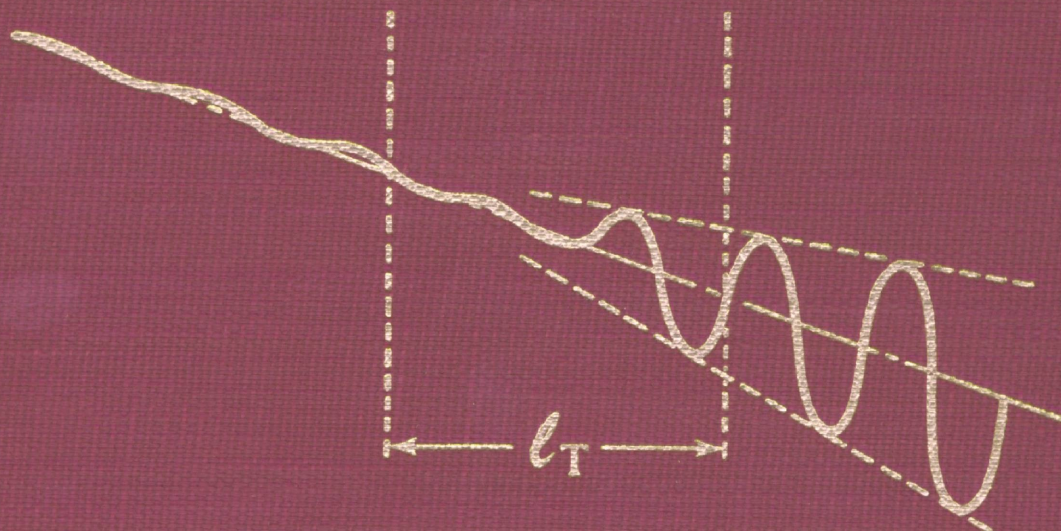



C 13.44:141

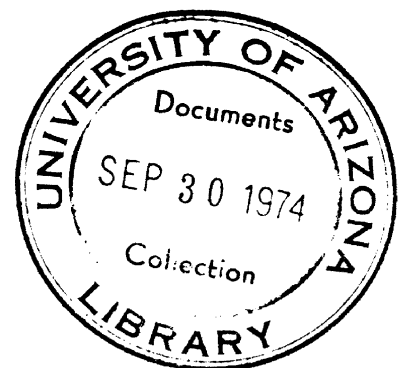

# THE MEASUREMENT OF LUMPED PARAMETER IMPEDANCE: A METROLOGY GUIDE

---

R. N. Jones

Electromagnetic Metrology Information Center  
Electromagnetics Division  
Institute for Basic Standards  
National Bureau of Standards  
Boulder, Colorado 80302

W. J. Anson

Editor, Metrology Guides

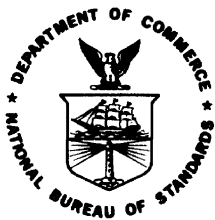

---

U.S. DEPARTMENT OF COMMERCE, Frederick B. Dent, *Secretary*  
NATIONAL BUREAU OF STANDARDS, Richard W. Roberts, *Director*

Issued June 1974

**Library of Congress Cataloging in Publication Data**

Jones, Raymond Nelson, 1928-

**The Measurement of Lumped Parameter Impedance.**

**(NBS Monograph 141)**

Bibliography: p.

Supt. of Docs. no.: C13.44.141

1. Impedance (Electricity) 2. Electric measurements. I. Title. II. Series: United States.

National Bureau of Standards. Monograph 141.

QC100.U556 no. 141 [TK315] 389'.08s [621.37'4]  
74-8060

**National Bureau of Standards Monograph 141**

Nat. Bur. Stand. (U.S.), Monogr. 141, 211 pages (June 1974)

CODEN: NBSMA6

**U.S. GOVERNMENT PRINTING OFFICE  
WASHINGTON: 1974**

---

For sale by the Superintendent of Documents, U.S. Government Printing Office  
Washington, D.C. 20402 (Order by SD Catalog No. C13.44:141).  
Price \$5.50 Stock Number 0303-01289



THE MEASUREMENT OF LUMPED PARAMETER IMPEDANCE  
A METROLOGY GUIDE

Abstract

The measurement of two-terminal impedance in the 30 kHz to 300 MHz range involves a variety of different methods including null, resonance, active and comparison. Each method is represented by a number of instruments having specific capabilities, strengths, and weaknesses. This metrology guide is intended to assist the scientist who is not intimately familiar with impedance measurement, in the selection and use of the best instrument for a particular requirement. Information is included on range and accuracy capabilities as well as availability and ease of operation. In addition to providing help in the selection of the appropriate instrument, there are operating tips which enhance accuracy, criteria for choosing standards, means for extending normal measurement range of an instrument, a discussion on generators and detectors, and a section on the evaluation and use of adapters. Finally, an extensive bibliography is included to assist in pursuing a particular problem beyond the depth of the guide.

Key Words: Adapters; capacitance; capacitors;  
detectors; generators; impedance  
instruments; impedance standards;  
inductance; inductors; measurement  
methods; reactance; resistance;  
resistor; standards.

## EDITOR'S NOTE

This Guide is one of a series of Metrology Guides sponsored by The Electromagnetic Metrology Information Center of the National Bureau of Standards Electromagnetics Division designed to be critical comparisons of measurement methods for a variety of electromagnetic quantities. The objective is to provide guidance in the selection, use and evaluation of methods for a particular application. These Guides, written by measurement specialists and based on extensive literature searches, are tailored to the needs of technical people who may not possess specialized training in the measurement of the quantity that is the subject of a particular guide. Therefore, these Guides will be useful to teachers, design engineers, contract monitors, and practicing metrologists, as well as general engineers and scientists who need specific measurement know-how but do not have the time or facilities to do their own research and study on the complexities involved. With the above objective in mind, each guide includes the following:

1. A description of the physical principles underlying the measurement technique.
2. An indication of the accuracy obtainable with each method whether by discussion of typical ranges and accuracies or through discussion of the error equations.
3. A discussion of the technical strengths and weaknesses of each technique. This includes a discussion of the sources of error or, wherever possible, the error equations of specific operating systems.
4. A discussion of the instrumentation requirements (including standards) for each technique.
5. Operational problems, suggestions, or examples.
6. An extensive bibliography to assist the reader in pursuing the details of methods beyond the depth of the guide.

If the reader wishes to receive information about any future Guides or wishes to comment on this Guide, please use the form at the back of the book.

W. J. Anson  
Editor -  
Metrology Guide Series

## ACKNOWLEDGMENT

"No man is an island unto himself." The truth of this quotation has been abundantly clear to me in the preparation of this manuscript. Help has come from so many sources they would be difficult to recount, but permit me to express my gratitude to some who contributed a great deal. Wilbur J. Anson of NBS provided assistance, guidance and encouragement from start to finish. My readers were William E. Bostwick, now retired from Lawrence Radiation Laboratory, John L. Dalke and Robert M. Jickling of NBS. Ginger Fears and Darwin B. Miner did the drafting and illustrations, and Margaret Woolley typed the whole thing---more than once. To all of you, and many others, my sincere thanks.



## CONTENTS

	<u>Page</u>
LIST OF FIGURES.....	ix
LIST OF TABLES.....	xiii
ABSTRACT.....	iii
EDITOR'S NOTE.....	iv
ACKNOWLEDGMENT.....	v
1. INTRODUCTION.....	1
1.1. Purpose.....	1
1.2. Scope Of The Guide.....	1
1.3. Accuracy Limits.....	3
1.4. How To Use This Guide.....	10
1.5. From The Old To The New.....	10
2. MEASUREMENT CATEGORIES AND EQUIVALENT SERIES AND PARALLEL RELATIONSHIPS.....	12
3. MEASUREMENT METHODS AND THEIR CAPABILITIES.....	16
3.1. Null Method (two terminal).....	17
a. Principle of the Null Method.....	17
b. Characteristics of ac Bridges.....	18
c. Error Sources.....	20
d. Strengths and Weaknesses.....	21
3.2. Null Method (three terminal).....	23
a. General Comments.....	23
b. Strengths and Weaknesses.....	24
3.3. Resonance Methods.....	29
a. General Comments.....	29
b. Series Resonance.....	29
c. Parallel Resonance.....	31
d. Resonance Methods For Determining Residual Impedances.....	33
(1) Grid Dip Meter.....	33
(2) Three Frequency Method.....	34
e. Error Sources.....	36
f. Strengths and Weaknesses of Resonance Methods.....	36

Contents (cont.)

	<u>Page</u>
3.4. Active Methods.....	40
a. General Comments.....	40
b. Vector Impedance Meters.....	40
c. L-C Meters.....	42
d. 6-Port Coupler.....	43
e. Error Sources.....	44
f. Strengths and Weaknesses.....	45
3.5. Comparators or Differential Measurements.....	49
3.6. Automated Measurements.....	51
3.7. Other Methods.....	52
a. Time Domain Reflectometer.....	52
b. Frequency Domain Reflectometer.....	53
c. Swept Frequency.....	53
d. Slotted Line.....	54
e. Return Loss Bridge.....	54
4. INSTRUMENTS FOR VARIOUS METHODS.....	58
4.1. Null Instruments.....	59
a. Maxwell Bridge.....	59
b. Schering Bridge.....	64
c. Admittance Ratio Bridge.....	70
d. Transformer Ratio Bridge.....	75
e. Twin-T Bridge.....	82
f. Thurston Bridge.....	88
g. Young Bridge.....	94
h. Byrne Bridge.....	99
i. Q-Bridge.....	106
4.2. Resonance Instruments.....	111
a. Q-Meter.....	111
b. Immittance Transcomparator.....	118
4.3. Active Instruments.....	122
a. Vector Impedance Meter.....	122
b. L-C Meter.....	128
c. Vector Voltmeter.....	133
d. 6-Port Coupler.....	135
4.4. Comparator Instruments.....	138
5. MEASUREMENT TIPS AND TECHNIQUES.....	139

Contents (cont.)

	<u>Page</u>
6. STANDARDS.....	142
6.1. General Comments.....	142
6.2. Why Are Impedance Calibrations Expensive?.....	144
6.3. Keeping Calibration Costs Down...A Tip On Maintaining Standards.....	145
6.4. What To Look For In Choosing A Standard.....	145
6.5. Coaxial Lines.....	147
7. RANGE EXTENSION.....	148
7.1. The Series Configuration.....	148
7.2. The Parallel Configuration.....	153
8. GENERATORS AND DETECTORS.....	155
8.1. Phase-Sensitive Detectors.....	159
9. APPLICATION AND EVALUATION OF ADAPTERS.....	161
9.1. Introduction To The Adapter Problem.....	161
9.2. What Is An Adapter?.....	161
9.3. Usual Two-Port Representations of Adapters.....	164
a. Uniform Transmission Line.....	164
b. " $\pi$ " or "T" Network.....	166
c. "L" Network.....	166
d. Single Element Representation.....	169
9.4. Measurement of Open-Circuit Admittance, Electrical Length, And Short-Circuit Location In Non-Precision Connectors and Adapters.....	171
10. APPENDIX I. DEFINITIONS, UNITS AND SYMBOLS.....	182
11. BIBLIOGRAPHY.....	187



LIST OF FIGURES

<u>Fig. No.</u>	<u>Title</u>	<u>Page</u>
1-1	± 0.1 percent uncertainty limits for two-terminal capacitance measurement.....	7
1-2	± 0.1 percent uncertainty limits for two-terminal inductance measurement.....	8
1-3	± 0.1 percent uncertainty limits for two-terminal resistance measurement.....	9
3-1	(no caption).....	17
3-2	Null methods for two-terminal capacitance measurement: Instruments and their approximate ranges in frequency and magnitude.....	25
3-3	Null methods for two-terminal inductance measurement: Instruments and their approximate ranges in frequency and magnitude.....	26
3-4	Null methods for two-terminal resistance measurement: Instruments and their approximate ranges in frequency and magnitude.....	27
3-5	Null methods for two-terminal Q or dissipation factor measurement: Instruments and their approximate ranges in frequency and magnitude.....	28
3-6a	Series resonant circuit.....	29
3-6b	Response of series resonant circuit.....	29
3-7a	Parallel resonant circuit.....	31
3-7b	Response of parallel resonant circuit.....	31
3-8	Grid dip meter application.....	33
3-9	Three frequency method, equivalent method.....	34
3-10	Three frequency method, data analysis.....	35
3-11	Resonance methods for two-terminal capacitance measurement: Instruments and their approximate ranges.....	38
3-12	Resonance methods for two-terminal inductance measurement: Instruments and their approximate ranges in frequency and magnitude.....	39

List of Figures (cont.)

		<u>Page</u>
3-13	Active method for measuring impedance.....	41
3-14	Measurement of small impedances using constant current generator.....	41
3-15	Measurement of large impedances using constant voltage generator.....	42
3-16	Impedance measurement using the 6-port coupler: Relation between voltage (v), current (i), incident voltage wave (a) and reflected voltage wave (b).....	44
3-17	Active methods for two-terminal inductance measurement: Instruments and their approximate ranges in frequency and magnitude.....	46
3-18	Active methods for two-terminal capacitance measurement: Instruments and their approximate ranges in frequency and magnitude.....	47
3-19	Active methods for two-terminal resistance measurement: Instruments and their approximate ranges in frequency and magnitude.....	48
4-1	(no caption).....	59
4-2	Maxwell impedance bridge: Range of inductance vs frequency.....	62
4-3	Maxwell impedance bridge: Range of resistance vs frequency.....	63
4-4a	(no caption).....	64
4-4b	(no caption).....	66
4-5	Schering bridge: Range of resistance vs frequency...	68
4-6	Schering bridge: Range of capacitance vs frequency..	69
4-7	(no caption).....	70
4-8	Admittance ratio bridge: Range of conductance vs frequency.....	73
4-9	Admittance ratio bridge: Range of capacitance vs frequency.....	74

List of Figures (cont.)

	<u>Page</u>
4-10	(no caption)..... 75
4-11	Transformer ratio bridge: Range of resistance vs frequency..... 79
4-12	Transformer ratio bridge: Range of capacitance vs frequency..... 80
4-13	Transformer ratio bridge: Range of inductance vs frequency..... 81
4-14	(no caption)..... 82
4-15	Twin-T bridge: Range of resistance vs frequency..... 85
4-16	Twin-T bridge: Range of capacitance vs frequency..... 86
4-17	Twin-T bridge: Range of inductance vs frequency..... 87
4-18	(no caption)..... 88
4-19	Thurston bridge: Range of conductance vs frequency... 92
4-20	Thurston bridge: Range of positive or negative capacitance vs frequency..... 93
4-21	(no caption)..... 94
4-22	Young bridge: Range of conductance vs frequency..... 97
4-23	Young bridge: Range of capacitance vs frequency..... 98
4-24	(no caption)..... 99
4-25	Byrne bridge: Range of resistance or impedance magnitude vs frequency..... 103
4-26	Byrne bridge: Range of capacitance vs frequency..... 104
4-27	Byrne bridge: Range of inductance vs frequency..... 105
4-28	(no caption)..... 106
4-29	Q-bridge: Range of Q vs frequency..... 109
4-30	Q-bridge: Range of capacitance vs frequency..... 110
4-31	(no caption)..... 111



List of Figures (cont.)

	<u>Page</u>
4-32	Q-meter: Range of Q vs frequency..... 115
4-33	Q-meter: Range of capacitance vs frequency..... 116
4-34	Q-meter: Range of inductance vs frequency..... 117
4-35	(no caption)..... 118
4-36	Immittance transcomparator: Range of Q vs frequency..... 121
4-37	(no caption)..... 122
4-38	Vector impedance meter: Range of resistance or impedance magnitude vs frequency..... 125
4-39	Vector impedance meter: Range of inductance vs frequency..... 126
4-40	Vector impedance meter: Range of capacitance vs frequency..... 127
4-41	(no caption)..... 128
4-42	L-C meter: Range of inductance vs frequency..... 131
4-43	L-C meter: Range of capacitance vs frequency..... 132
4-44	(no caption)..... 133
4-45	(no caption)..... 135
4-46	Measurement uncertainty of 6-port coupler vs directivity of hybrid junctions..... 136
6-1	Derivation of NBS immittance standards..... 143
7-1	(no caption)..... 148
7-2	(no caption)..... 149
7-3	(no caption)..... 150
7-4	(no caption)..... 151
7-5	(no caption)..... 153
8-1	(no caption)..... 155
8-2	(no caption).....159

List of Figures (cont.)

		<u>Page</u>
9-1	Adapter represented as a uniform transmission line.....	165
9-2	Adapter represented as a "π" or "T" network.....	167
9-3	Adapter represented as equivalent "L" network.....	168
9-4	Adapter represented as a single element.....	170
9-5	Zero-length adapter for type N male connectors (cross-section illustration).....	173
9-6	Zero-length adapter for type N male connectors (engineering cross-section).....	174
9-7	Connection arrangements for measuring adapter capacitances and open-circuit fringe capacitances at 1 kHz.....	175
9-8	Connection arrangement for measuring electrical length of adapter utilizing zero-length adapter.....	180

LIST OF TABLES

Table I.	Instruments Measuring Equivalent Series Impedance....	55
Table II.	Instruments Measuring Equivalent Parallel Admittance.....	57

## 1. INTRODUCTION

### 1.1. Purpose

In preparing this metrology guide, it has been assumed that the potential user is broadly familiar with the field of electrical measurement but not intimately familiar with the methods, techniques and instrumentation for making impedance measurements. The guide anticipates a situation where impedance measurements are known to be necessary but the best way to go about making them is not known. The heart of the guide is the subject matter found in Section 3 where various methods are covered and in Section 4 where specific instruments, which are the embodiment of the methods covered in Section 3, are discussed. The other sections are intended to be supportive of the material found in Sections 3 and 4, by providing measurement tips, information on standards, range extension techniques, generators and detectors, and the use and evaluation of adapters.

### 1.2. Scope Of The Guide

This guide is not all-inclusive of the subject of impedance measurement and the reader should understand at the outset what he can or cannot expect to find. To help in establishing the bounds of subject matter included, consider the ideal impedance-measuring instrument as having the following characteristics and capabilities:

- (1) unrestricted frequency range
- (2) unrestricted impedance range
- (3) unrestricted capabilities with respect to bias, ambience, applied power, etc.
- (4) error free
- (5) performs measurements instantaneously
- (6) zero acquisition cost
- (7) zero operating cost.



Obviously no such instrument exists and if it did there would certainly be no need for a metrology guide. All instruments or methods fall short of all of these criteria, but all have strong or weak points with respect to each. This guide is an attempt to present a body of useful information which will simplify the task of deciding which methods and instruments are best suited for particular requirements. The information presented should make possible a critical comparison of methods and instruments with the result that the user will be able to decide correctly upon the best method and ultimately upon the best instrument for his application. Any such decision must be preceded by an ordering of priorities as to which criteria are most important, such as speed versus accuracy, accuracy versus cost, frequency range versus parameter range, etc.

This guide will not attempt to encompass the entire subject of impedance measurement so that some of the criteria mentioned must be reduced to more manageable proportions. For present purposes, the frequency range will be confined to a lower limit of 30 kHz and an upper limit of 300 MHz, although some of the methods and instruments to be discussed are usable either below or above these limits. Impedance measurement above 300 MHz is the subject of another guide of this series.

Impedance measurement in the 30 kHz to 300 MHz range has some unique problems and peculiarities which arise largely because it is a transition region from open wires to coaxial lines as the medium for propagating energy. This creates difficulties and uncertainties brought about by many different types of connectors and the need to adapt from one to another. This is also the frequency region where a quarter of a wavelength begins to approach the physical size of a practical laboratory component so that it becomes practical and desirable to use both lumped circuit and distributed circuit theory.

A reduction is also necessary in the impedance range criteria and this guide will be restricted to passive, two-terminal measurements and passive, three-terminal measurements. This specifically excludes negative resistance (active devices), and balanced measurements even though some of the methods and instruments discussed may have such capabilities. Also excluded are measurements under bias, high power or ambient environmental extremes.

In Sections 3 and 4, strengths and weaknesses are enumerated for specific methods and instruments. These strengths and weaknesses have been determined by comparison with the criteria chosen to represent the ideal instrument. They are not intended as a blanket recommendation for or against any particular method or instrument but only as an aid to objective selection based upon the needs of a particular user.

It is also recognized that methods or instruments exist which are not included here. In such instances it is due either to the fact that they were not found in the literature search or that they were not deemed to be of wide enough practical use to be included. It is also notable that there are many variations on the methods and instruments that are included. Hopefully the omissions are not of major consequence.

### 1.3. Accuracy Limits

When two or more methods or instruments have been identified which can perform a particular measurement, the choice is often made in favor of the one which is the most accurate. This is not always an easy thing to determine and quick glances at the percentage tolerances provided by manufacturers, although helpful, may not tell the whole story. There are some important questions which should be answered before a final decision is made:

- (1) In what mathematical form does the instrument present the measurement data?

Some instruments read out is the polar form of impedance magnitude and phase angle ( $Z \angle \theta$ ), others in the rectangular form of equivalent series impedance ( $R \pm jx$ ) or equivalent parallel admittance ( $G \pm j\beta$ ). Still others give either capacitance or inductance for the quadrature component. Q or dissipation factor are sometimes given and so it goes until the variations seem almost endless. To compare the accuracy capabilities of various instruments, it is necessary to convert to a common mathematical form and examine carefully the significance of percentages as they apply to specific parameters. To make a thorough accuracy comparison it is also necessary to consider impedances having a wide variety of magnitudes and phase angles. This will provide a good overall comparison as to how well the largest and smallest components of a complex impedance vector can be measured.

- (2) What is the resolution of the instrument?

The smallest scale division on a dial or a meter becomes very important, especially when measuring very small values, and manufacturers often add a vernier to secure an additional decimal place in data resolution.

- (3) What about other terms in the accuracy statement?

Particularly with bridges or null instruments, accuracy statements often include terms containing frequency and also terms which vary depending upon the nature of the impedance being measured. For example, the accuracy of a resistance value may depend upon how much inductance was present in the unknown. Such "cross products" are often very important especially when measuring the smaller component of a very high or a

very low Q impedance, and can greatly modify the basic percentage accuracy capability for that particular type of measurement.

- (4) What kind of connectors does the instrument have at its unknown terminals, or how is the unknown connected for measurement?

Connector requirements can be extremely important and should be considered very carefully in all measurement applications. Even though one particular instrument may appear to provide the best accuracy, a great deal can be lost if complicated adaptors or long measurement leads are required. This problem becomes increasingly serious as the measurement frequency increases and wavelengths begin to approach the physical dimensions of practical impedance components.

In Sections 3 and 4 of this guide are a number of graphs showing the capabilities of various methods and instruments. It would have been convenient for the user if some accuracy limits could have been shown on these charts which would have clearly indicated which methods or instruments are the most accurate. Although the graphs were prepared showing resistance, inductance, conductance and capacitance measuring capabilities as appropriate for each method or instrument, no way was found to show accuracies in individual cases which would have been fair assessments in all cases. In lieu of this, representative percentage uncertainty figures have been given in the short narratives, but as stated above, these may not tell the whole story in individual cases and should not be accepted without careful examination.

In order to provide some feel for measurement uncertainty a criteria of  $\pm 0.1$  percent is shown on the charts to illustrate what is attainable at the present state-of-the-art, and does not mean that the particular instrument or method has a  $\pm 0.1$  percent capability. The  $\pm 0.1$  percent criteria for uncertainty used in

the charts was derived under the assumption that manufacturing tolerances of  $\pm 0.001$  inch could be guaranteed for commercial standards. Using this assumption it has been shown [A-1] that  $3 \times 10^{-8}$  Henry,  $2 \times 10^{-13}$  Farad and 1 ohm are the smallest two-terminal values of inductance, capacitance and resistance which can be measured to an uncertainty of  $\pm 0.1$  percent. Figures 1-1, 1-2 and 1-3 show how these uncertainty limitations apply to these quantities over the 30 kHz to 300 MHz frequency range.

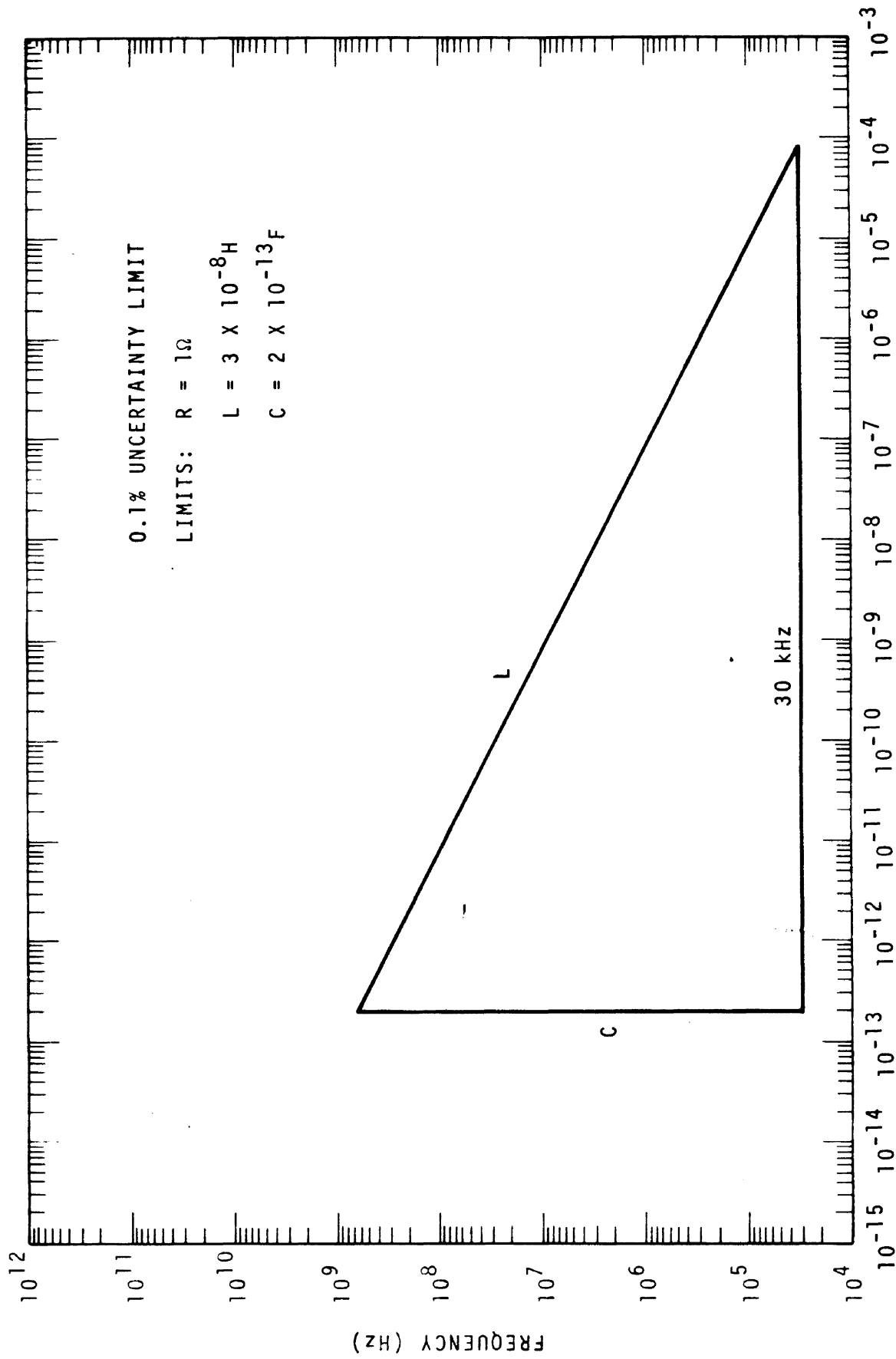

Figure 1-1.  $\pm 0.1$  percent uncertainty limits for two-terminal capacitance measurement.



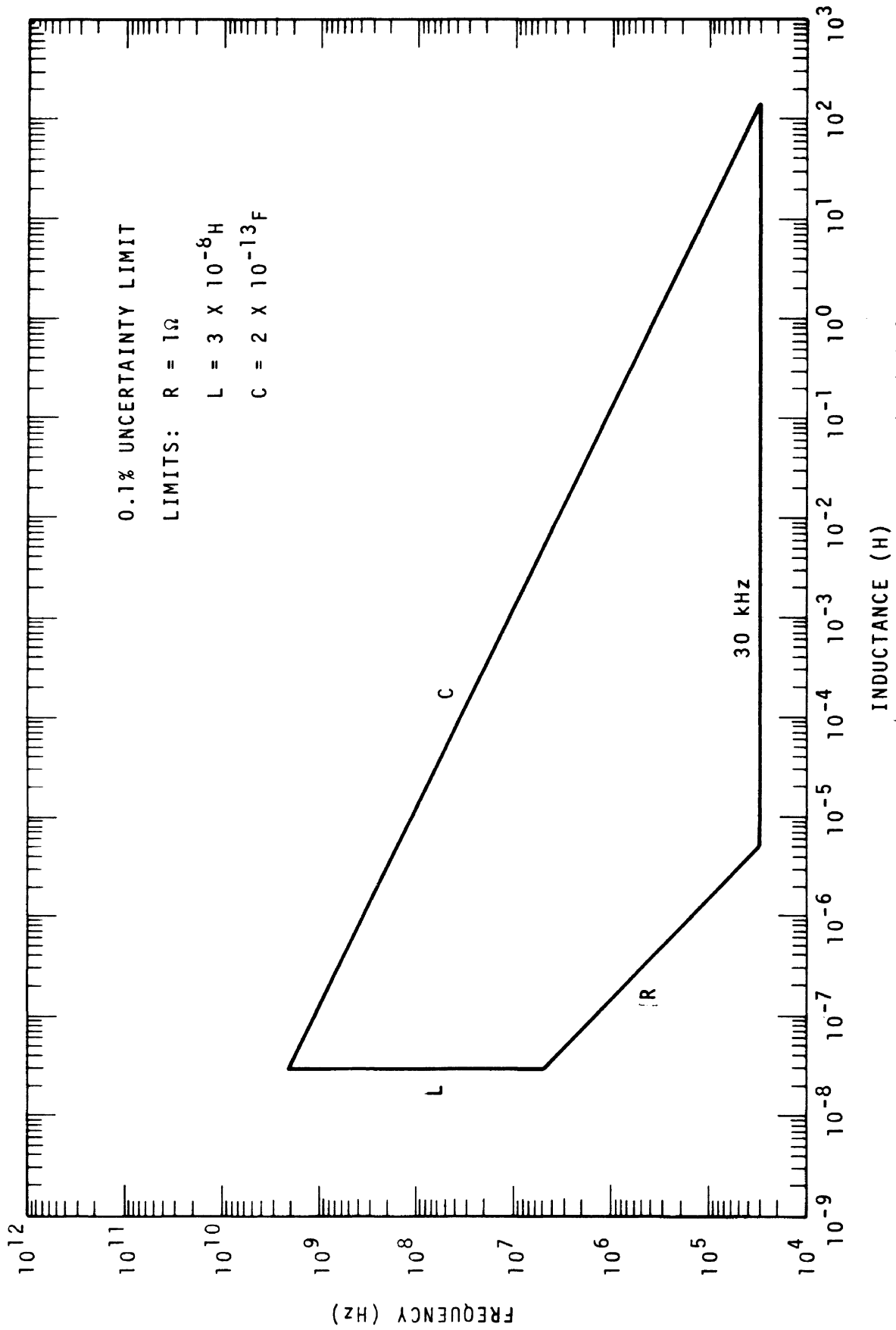

Figure 1-2.  $\pm 0.1$  percent uncertainty limits for two-terminal inductance measurement.

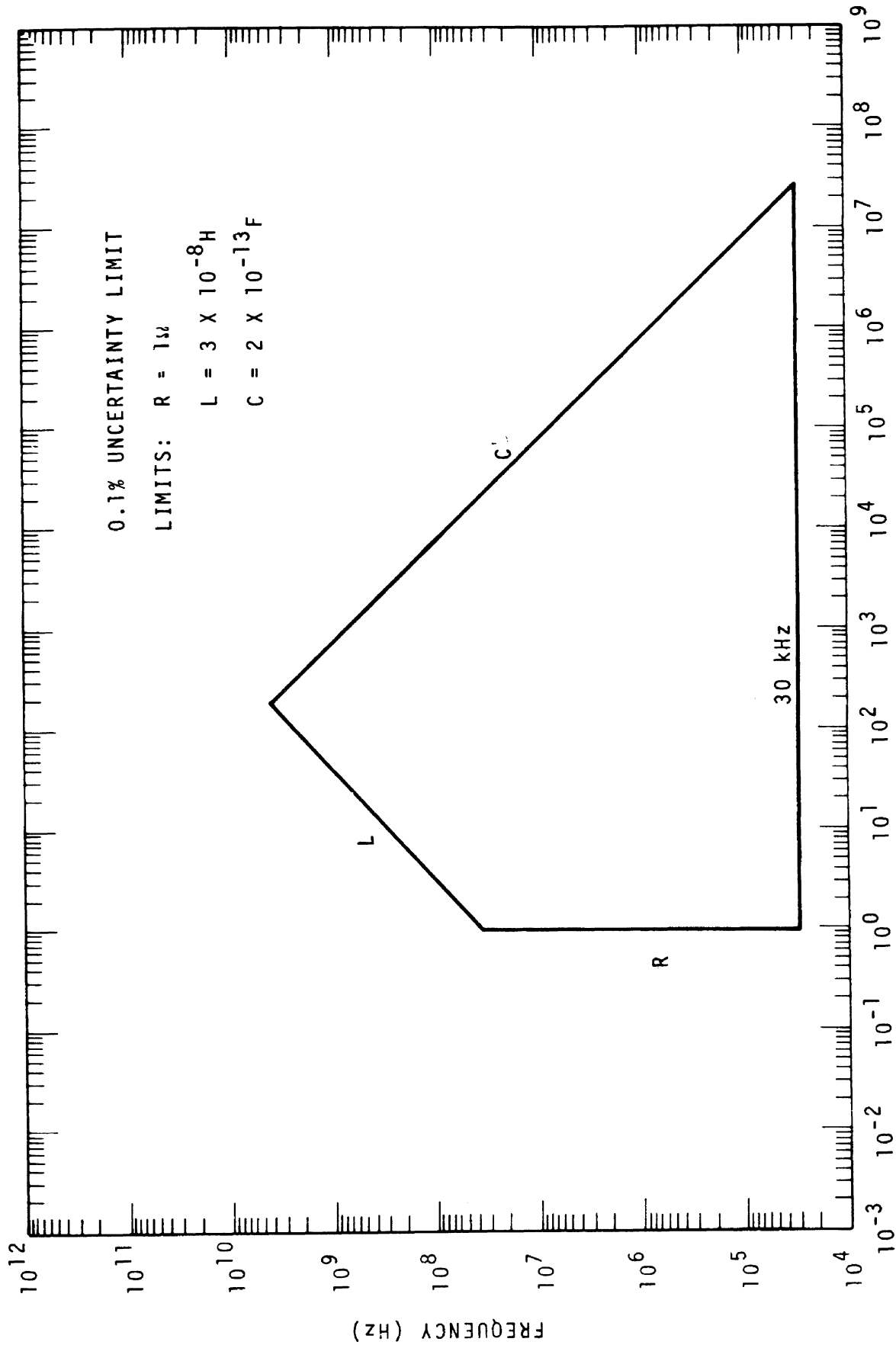

Figure 1-3.  $\pm 0.1$  percent uncertainty limits for two-terminal resistance measurement.

#### 1.4. How To Use This Guide

The main purpose of this guide is to aid the user in determining what method or instrument to use for a particular measurement requirement. Sections 2, 3 and 4 will be of most help in this regard. In Section 2 practical measurements falling within the scope of the guide are categorized and the user is provided with page numbers where appropriate methods or instruments are discussed. Section 3 is concerned with methods of measurement wherein some information is given regarding the theory behind a particular method, its strengths, weaknesses and capabilities for measuring various impedance parameters. Also in Section 3 are graphs illustrating the measurement capabilities of each method. These graphs can be used for quick reference and also provide, in one location, a summary of capabilities of all the instruments utilizing a particular method. This will aid in critically comparing the capabilities of specific instruments.

Section 4 begins with a summary table showing the generalized capabilities of all the instruments covered in that section. Following the summary are detailed discussions of each instrument, including circuits, equations, accuracy capabilities, strengths and weaknesses.

The other sections provide measurement tips and suggestions, criteria for choosing standards, range extension techniques to help the user make better use of an instrument, a discussion on generators and detectors, together with some new information on the use and evaluation of adapters.

#### 1.5. From The Old To The New

Like most everything else, the approach to impedance measurement has changed and continues to change. Many of the methods and instruments included here are products of past decades and the reader may wonder why they have been included. This is especially

true in the null and resonance categories where many of the instruments have been superseded by more modern equipment. However, just because something is old does not mean that it isn't good or useful, and even though some of these instruments are no longer found in the current manufacturers catalogs does not mean that they are no longer in use. In some instances it may be found that the newer, faster and more exotic instruments may not yet possess the accuracy, stability and dependability characteristics of their predecessors and so it is still wise to keep the old one for a while longer. With this in mind a strong emphasis has been placed on those instruments which can be said to have preceded the space age.

Newer generation equipment emphasizes speed of measurement, broad frequency range capabilities and automatic data handling capabilities, and is frequently interfaced with a computer facility. Versatility is being achieved to a greater degree and it is not uncommon to find measurement systems capable of measuring many electrical parameters over very wide frequency ranges. In Sections 3.6 and 3.7 the emphasis is primarily on equipment and measurement approaches which are characteristic of the newer generation approach to measurement.

## 2. MEASUREMENT CATEGORIES AND EQUIVALENT SERIES AND PARALLEL RELATIONSHIPS

The lumped impedance of any device may be represented either by a series or a parallel combination of circuit elements, whichever is more convenient, but it is often necessary to convert from one form to the other, requiring that the following relationships be used:

Series to Equivalent Parallel:

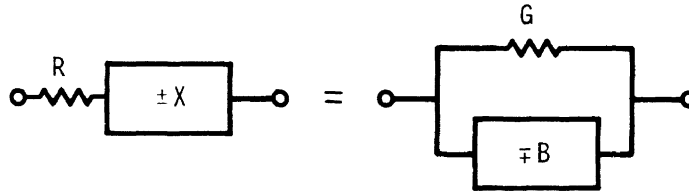

$$Z = R \pm jX$$

$$Y = \frac{1}{R \pm jX} = G \mp jB$$

$$G = \frac{R}{R^2 + X^2}$$

$$B = \mp \frac{X}{R^2 + X^2}$$

Parallel to Equivalent Series:

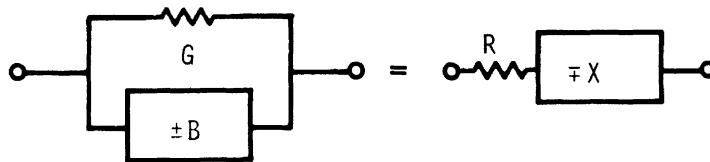

$$Y = G \pm jB$$

$$Z = \frac{1}{G \pm jB} = R \mp jX$$

$$R = \frac{G}{G^2 + B^2}$$

$$X = \mp \frac{B}{G^2 + B^2}$$

As an aid to illustrating the measurement capabilities of the various methods and instruments to be found in Sections 3 and 4, it is useful to categorize various types of impedances and give some practical examples which are characteristic of the various series and parallel combinations of in-phase and quadrature components.

By varying the signs and magnitudes of the parameters R, X, G and B, all possible impedance or admittance values can be obtained, but because this guide will be concerned only with passive quantities, negative resistance (-R) and negative conductance (-G) will be excluded.

Category	Series		Equivalent Parallel		Practical Example	Pages
	R	X	G	B		
A	Small	Small(+)	Large	Large(-)	Short circuit or small resistance or small inductance	40,49,59,64,75,133,135
B	Large	Large(-)	Small	Small(+)	Open circuit or small capacitance or large resistance	23,29,40,49,64,70,75,82,94,118,133,135
C	Large	Small(+)	Small	Small(-)	Resistor (large, inductive, low Q)	40,49,59,64,75,82,88,133,135
D	Large	Small(-)	Small	Small(+)	Resistor (large, capacitive, low Q)	23,40,49,59,64,70,75,82,88,133,135
E	Small	Large(+)	Small	Large(-)	Inductor (high Q)	29,40,49,59,64,75,106,111,118,128,133,135
F	Small	Large(-)	Small	Large(+)	Capacitor (high Q)	23,29,40,49,64,70,75,82,94,106,111,118,128,133,135

						Pages
G	Large	Large (+)	Large	Large (-)	Inductor (low Q)	40, 49, 59, 75, 88, 133, 135
H	Large	Large (-)	Large	Large (+)	Capacitor (low Q)	23, 40, 49, 70, 75, 88, 133, 135
I	<u>Z/θ</u>			<u>Y/θ</u>		40, 49, 99, 122, 133, 135

Category I, with the polar forms of impedance and admittance, is included because it can be used to illustrate the capabilities of instruments which utilize distributed parameter methods but operate in the lumped parameter region.

A typical and useful example of series to parallel relationships is the conversion of the series values of a high Q inductor to its equivalent parallel values. Assume a 0.25 μH inductor with a Q of 250; and a frequency of 30 MHz:

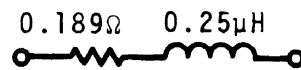

$$Q = \frac{\omega L}{R} \text{ WHERE } \omega = 2\pi f$$

$$\therefore R = \frac{2 \times 3.14 \times 30 \times 10^6 \times 0.25 \times 10^{-6}}{250}$$

$$R = 0.188\Omega$$

Converting to equivalent parallel values:

$$G = \frac{R}{R^2 + X^2}$$

$$B = - \frac{X}{R^2 + X^2}$$

$$G = \frac{0.188}{(0.188)^2 + (47.1)^2}$$

$$B = - \frac{47.1}{2220}$$

$$G = 84.9\mu S$$

$$B = - 21.2 \text{ mS}$$

$$C = \frac{B}{\omega} = - \frac{21.2 \times 10^{-3}}{1.88 \times 10^8}$$

$$= - 113 \text{ pF}$$

Therefore at 30 MHz the inductor would be an equivalent parallel circuit of:

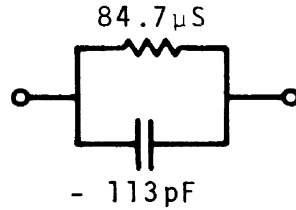

It is feasible and often desirable to measure such an inductor in terms of its equivalent parallel values through the use of an admittance bridge. Many similar examples can be devised which illustrate the importance and usefulness of equivalent series and parallel relationships.

Using this example, it can be seen that if it were required to measure such an impedance, it would come under categories E and I. Referring to Section 3, it could be measured by either null resonance or active methods. In Section 4 we find the following possibilities for measuring instruments:

<u>Null</u>	<u>Resonance</u>	<u>Active</u>
Maxwell Bridge	Q-Meter	L-C Meter
Schering Bridge	Immittance Transcomparator	Vector Impedance Meter
Transformer Ratio Bridge		Vector Voltmeter
Twin-T Bridge		6 port coupler
Q-Bridge		

To reduce this large number of possibilities further, the capabilities, accuracies, strengths and weaknesses given for particular instruments in Section 4 may be consulted.



### 3. MEASUREMENT METHODS AND THEIR CAPABILITIES

#### Introduction

In this section the principles and characteristics of various methods of measurement are examined. The methods considered include null, resonance, active and comparison. Two aids are available to assist in the selection of an appropriate method of measurement for a particular situation. Following the description of each method, the outstanding strengths and weakness are listed using as criteria the characteristics of the ideal instrument described in Section 1. Graphs are also provided to reveal quickly the ranges of the various impedance parameters which can be measured at a particular frequency. An attempt has been made to show on these same graphs the capabilities of specific instruments even though each is covered in more detail in Section 4. This has been done as an aid to illustrating and comparing the measurement options available within a given method.

For a particular measurement requirement there may be more than one method which may be used. In such cases other factors such as accuracy, cost, speed or operator skill will need to be considered. In other instances it may be found that there is only one method available so that the selection process is very simple, but once the merits of various methods have been considered, Section 4 will be found useful in making detailed comparisons between specific instruments

An exception to the foregoing is necessary in the case of the comparator method because of the different concept of measurement it implies as compared to the null, resonance and active methods. Actually any null, resonance, or active instrument may be used as a comparator providing a standard is available to use in the comparison procedure. Comparison is more of a procedure than a measurement method in this sense, although its importance is not to be overlooked for many applications. Graphs have been omitted in

the discussion on comparison, even though some instruments are marketed which are specifically intended for use as comparators.

3.1. Null Methods (two-terminal)

Categories Measured: All<sup>1</sup>

a. Principle of the Null Method

Although there are some very notable exceptions, null instruments most often are in the form of a Wheatstone bridge circuit. Voltage is impressed across one portion of the circuit and standards within the bridge are adjusted until a null indication is obtained across some other portion of the circuit. At the null or balanced condition, unique relationships exist between the device placed at the unknown terminals and the other elements of the circuit. To illustrate this principle, consider the simple Wheatstone circuit of figure 3-1,

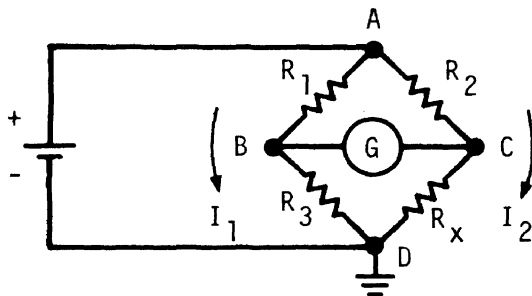

Figure 3-1.

with the resistance,  $R_x$ , connected to the unknown terminals. The other three resistances can be adjusted until the galvanometer,  $G$ , indicates a null so that the  $B$  and  $C$  corners of the bridge are at the same potential. Under this condition

$$I_1 R_1 = I_2 R_2$$

<sup>1</sup>Although individual null instruments have rather limited capabilities, the null method has been applied to nearly every type of impedance or admittance measurement.

$$\text{and } I_1 R_3 = I_2 R_x.$$

Dividing these two equations gives:

$$\frac{R_1}{R_3} = \frac{R_2}{R_x}$$

$$\text{or } R_x = \frac{R_2}{R_1} R_3 . \quad (3-1)$$

For ac measurements the resistors can be replaced by impedances or admittances, the battery by an oscillator and the galvanometer by an ac detector, so that the bridge equation becomes:

$$Z_x = \frac{Z_2}{Z_1} Z_3 , \quad (3-2)$$

which is the ac counterpart of the Wheatstone bridge.

#### b. Characteristics of ac Bridges

There are several significant observations to be made about the ac bridge equation and its implications regarding bridge characteristics and behavior:

(1) In practice  $Z_1/Z_2$  is usually made to be some multiple of 10, and  $Z_3$  is a variable standard. This arrangement is called a ratio-arm bridge and the unknown impedance (or admittance) in terms of a variable impedance (or admittance) in an adjacent arm.

(2) If the product  $Z_2 Z_3$  is made to be a definite multiple (usually some power of 10) and  $Z_1$  is a variable standard, then the characteristic product arm bridge is obtained and an unknown impedance will be measured in terms of an impedance in the opposite

arm. Because  $1/Z_1$  can be replaced by its parallel equivalent,  $Y_1$ , in the equation, the standard for impedance measurement ( $Z_x = R_x + j\omega L_x$ ) is invariably an admittance (conductance and capacitance in parallel) located in the arm opposite the unknown. This is done because variable capacitors are more suitable as standards than are variable inductors.

(3) The basic bridge circuit may be modified in many different ways by using various combinations of impedances and admittances. This permits variations in circuit design to accommodate different requirements, but no single circuit provides for all types of impedance and admittance measurement.

(4) In actual practice all reactance standards contain some resistance and all resistance standards contain some reactance. These unwanted residuals may also vary with setting, causing the resistive and reactive balance adjustments of the bridge to be interdependent.

(5) To produce a bridge of high accuracy requires high-quality standards and great care in shielding the internal bridge components from one another. Despite such precautions, the effects of some residual internal impedances cannot be completely eliminated and this restricts the frequency range and accuracy capabilities of any bridge.

In operating an impedance or an admittance bridge, an initial balance is made with either a short-circuit or an open-circuit placed at the unknown terminals. The short-circuit or open-circuit reference is then replaced by the unknown and the bridge rebalanced by adjusting the bridge standards. Many instruments are made to be direct reading so that no calculations are necessary. Often, however, some rather involved calculations may be required to correct for the errors caused by residual impedances. Such calculations are necessary in order to obtain the most accurate results.

In general, null instruments offer the most accurate means for impedance measurement. Instrument accuracy depends on the quality of internal shielding, standards, construction details and dial resolution. Instruments are designed around some center operating frequency where accuracy is best. Below this frequency uncertainties may increase because of loss of sensitivity (sharpness of balance). Above this frequency the major causes for increased uncertainty are residual circuit impedances. Some null circuits are frequency sensitive; this will be made obvious by the appearance of a frequency term in the balance equations. If a frequency term does not appear, then it is not an error source of first order importance unless the bridge is being used to measure a reactance which is of opposite sign from the normal bridge readout.<sup>2</sup> In such applications the frequency error will increase as the square of the frequency so that it becomes important that the measurement frequency be accurately known.

For most null instruments the range for Q-measurement is from  $10^{-3}$  to  $10^3$  although some admittance bridges will provide fairly reliable results up to  $10^4$ . Beyond these limits the accuracy is degraded to the point where the measurement is hardly more than qualitative. The Q-bridge is somewhat of an exception, but the Q-measuring feature is not based strictly on the null principle. Limitations in the purity or Q of practical bridge components limit the extremes to which Q is measurable. Null instruments are most accurate for measuring Q-values near 1, whereas resonance instruments are probably most accurate for measuring Q-values in the vicinity of 100. Of all the null instruments, the twin-T circuit described in Section 4.1 e, provides the best accuracy capabilities for the measurement of Q.

### c. Error Sources

Major sources of error in null instruments derive from a number of causes and limitations. Some of the more significant of these are as follows:

<sup>2</sup>See Section 7 on range extension.

(1) Resolution capability (the smallest measurable quantity). This is significant in measuring small immittances.

(2) Inaccuracy in ratio or product arms often appears as a percentage term in the uncertainty statement. This is significant in measuring large immittances.

(3) Errors due to uncertainty of measurement frequency. These are not allowed for in bridge accuracy statements so that it is the operators responsibility to insure that frequency errors do not appear.

(4) Especially in bridges, the expressions for measurement uncertainty will often contain terms to allow for the effect of residual impedances in various portions of the bridge circuit. In high quality instruments great effort is made to reduce these residuals or to compensate for them through the use of shielding or compensating circuitry. It is the effect of circuit residuals which ultimately limits the upper frequency at which a bridge is usable.

(5) Non-precision connectors at the interface between bridge and unknown contribute significant uncertainties, especially to the measurement of either very large or very small reactances.

#### d. Strengths and Weaknesses

In summary, some of the more noteworthy strengths and weaknesses of two-terminal null methods are listed below:

##### Strengths

- (1) High accuracy capability
- (2) Good for low Q measurements ( $\leq 10$ )
- (3) Excellent for use as a comparator
- (4) Superior long term stability
- (5) Commercially available in wide variety

### Weaknesses

- (1) The measurement procedure is relatively slow  
(except for automated bridges)
- (2) Limited capabilities in frequency range  
and range of parameters measured
- (3) Skilled operator required
- (4) Difficult to calibrate
- (5) Cannot be used to measure small impedances  
above about 30 MHz
- (6) Accuracy limitations in measuring minor  
component of complex immittance become  
severe for both high-Q and low-Q measurements

### 3.2. Null Method (three-terminal) Categories Measured: B,D,F,H

#### a. General Comments

Two-terminal methods are frequently inadequate for extremely small admittance measurements because capacitance to ground or other surrounding conductors may be so large that the admittance of interest is not detectable. As an example, interelement capacitances of vacuum tubes and transistors may be of the order of fractions of a picofarad. Such small capacitors are not measurable in two-terminal situations where capacitances to ground may be several picofarads. Such measurement problems are solved by the use of three-terminal or direct admittance instruments, most of which are of the null variety. Transformer bridges are used which avoid any effects of capacitance or admittance to ground in the bridge circuit, permitting the measurement of capacitances as small as  $10^{-15}$  Farads at frequencies up to 5 MHz. These bridges make use of the principle of Y to  $\Delta$  conversion in a very ingenious manner, so that ordinary two-terminal elements are used to provide three-terminal standards. The entire measurement circuit is electrostatically shielded, thus eliminating unwanted admittances either to ground or other conductors. The main use of these instruments is for the measurement of capacitances equal to 1000 picofarads or less, with two-terminal techniques being adequate for the larger values.

Three-terminal techniques require a thorough understanding of what is to be measured and the principles involved. Measurement errors become significant at higher frequencies, again because of the contribution of circuit residuals, ratio inaccuracies in the bridge transformer and connection errors. Three-terminal methods are very useful for "in situ" or remote measurements although the inductance of leads may be an important error source for remote measurements.



## b. Strengths and Weaknesses

### Strengths:

- (1) High accuracy for small admittances
- (2) Good for in situ measurement
- (3) Excellent for use as a comparator to measure small differences
- (4) High resolution of small admittance values
- (5) Commercially available

### Weaknesses:

- (1) Slow
- (2) Direct capacitance measurement range usually limited to values  $\leq 1000$  pF.
- (3) Limited frequency range (5 MHz is maximum)
- (4) Not easy to measure at different frequencies (compared to resonance methods)
- (5) Complete calibration difficult and time consuming
- (6) Requires operator training depending upon what kind of measurements are involved
- (7) Cannot be used for measurement of small impedances

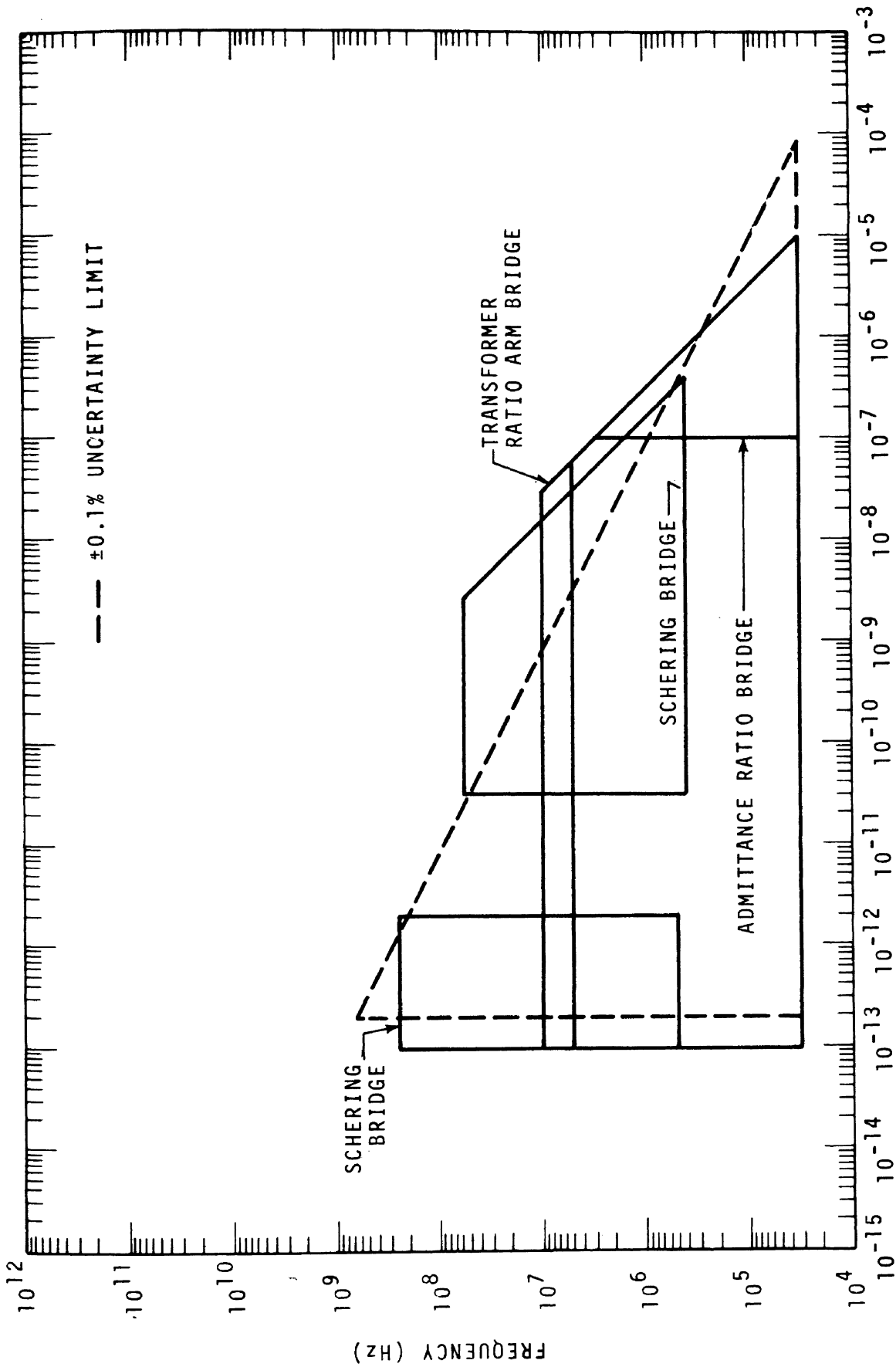

Figure 3-2. Null methods for two-terminal capacitance measurement: Instruments and their approximate ranges in frequency and magnitude.

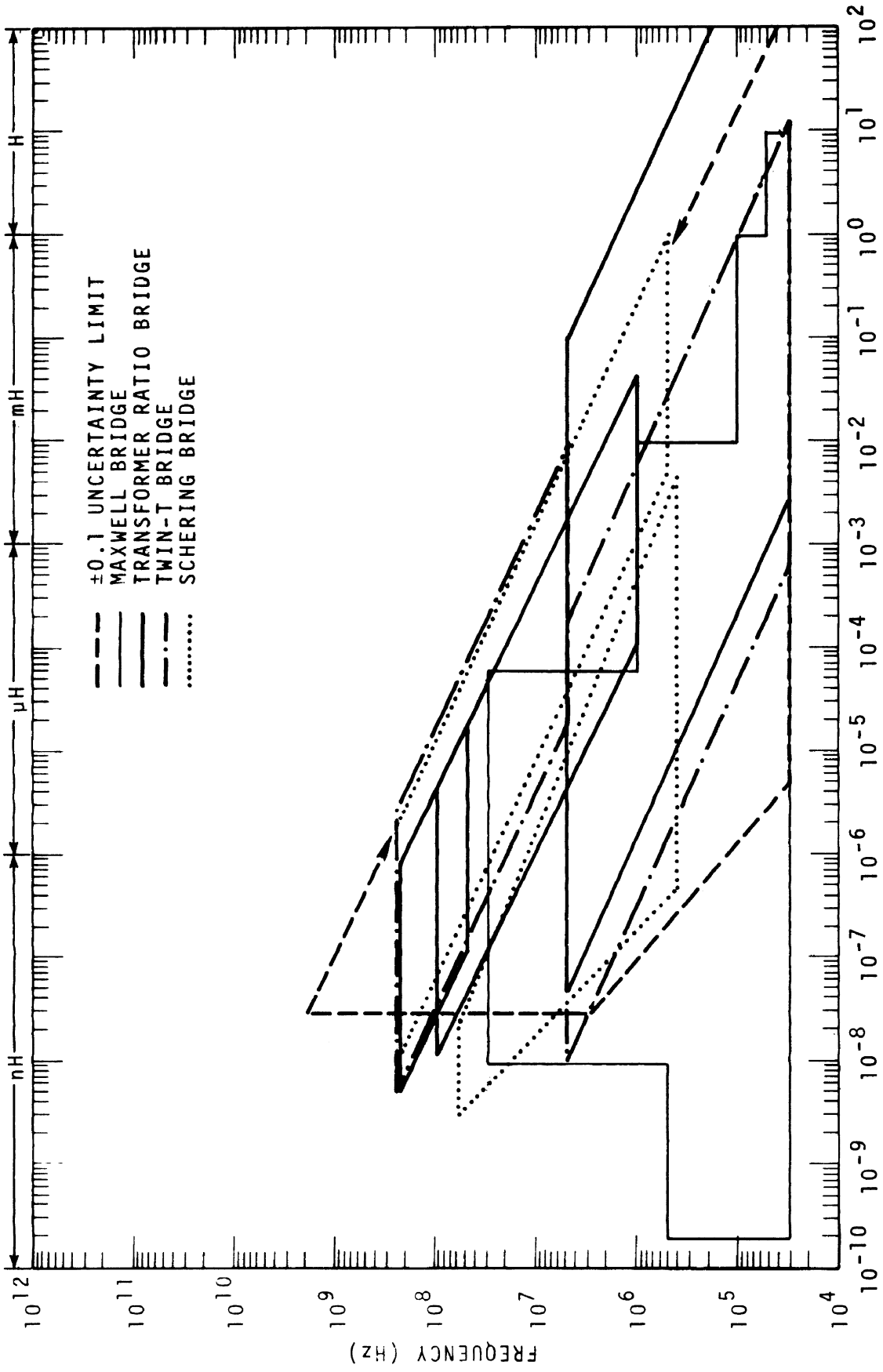

Figure 3-3. Null methods for two-terminal inductance measurement: Instruments and their approximate ranges in frequency and magnitude.

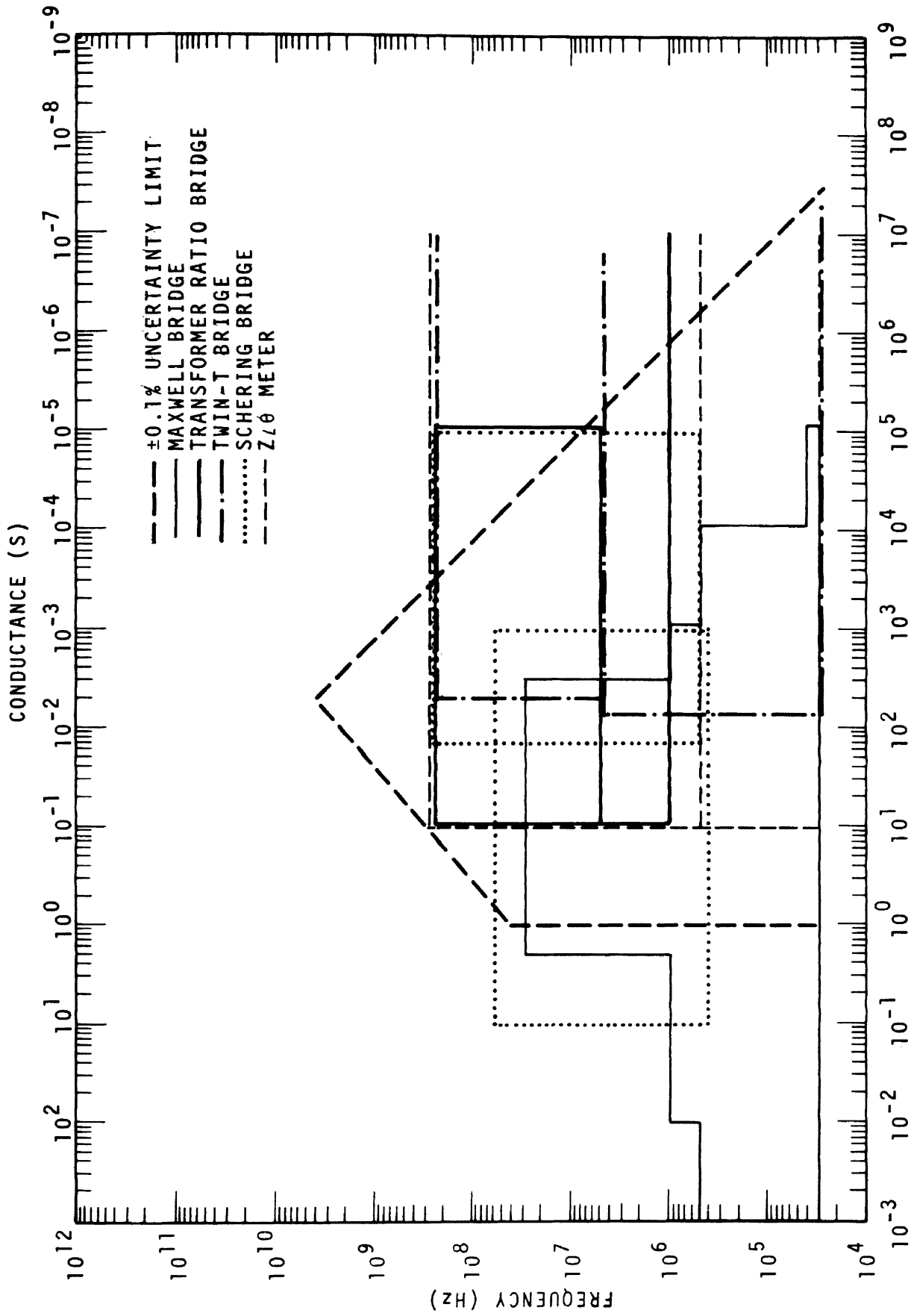

Figure 3-4. Null methods for two-terminal resistance measurement: Instruments and their approximate ranges in frequency and magnitude.

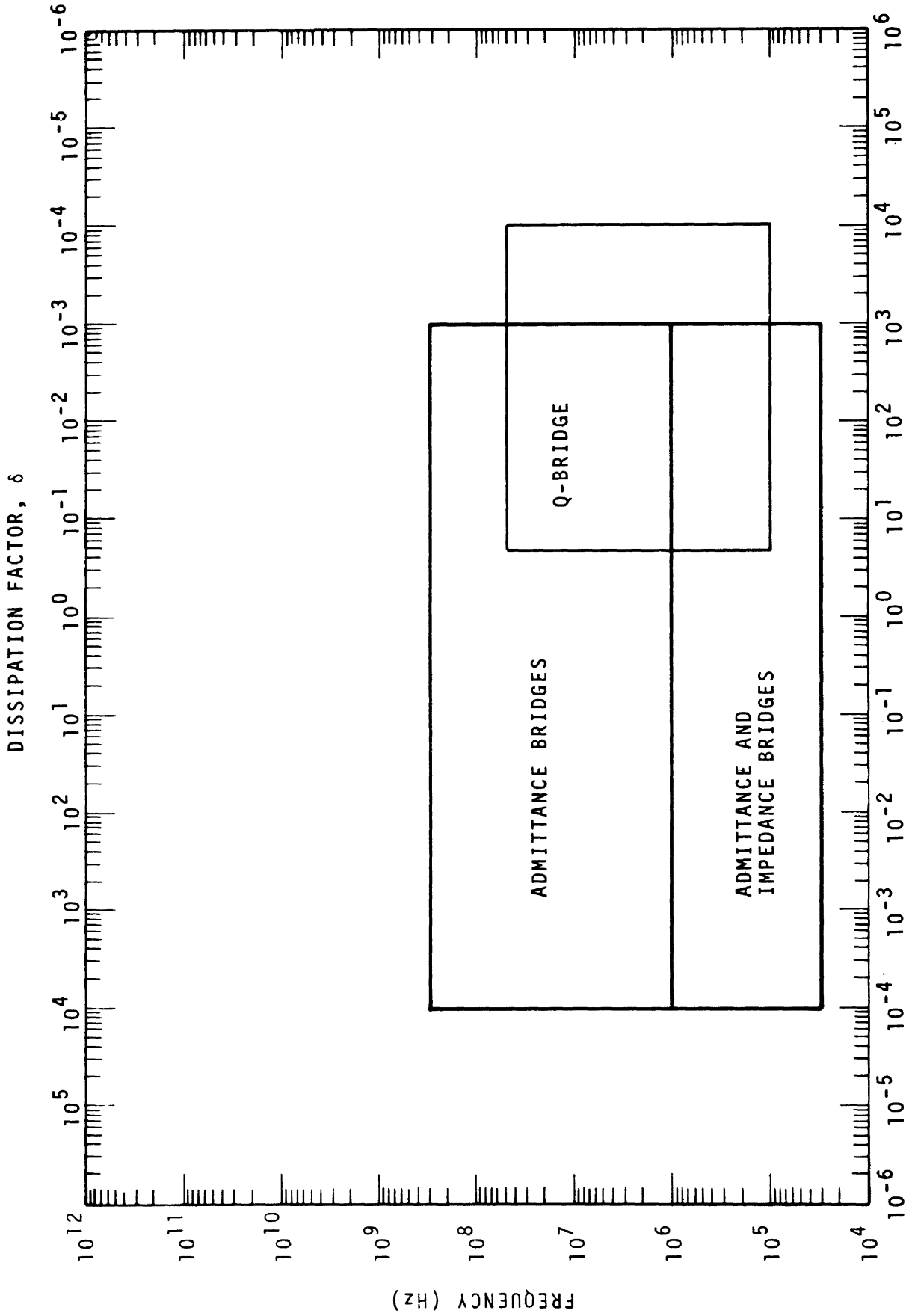

Figure 3-5. Null methods for two-terminal Q or dissipation factor measurement: Instruments and their approximate ranges in frequency and magnitude.

## a. General Comments

Resonance methods for impedance measurement are applicable in instances where the ratio of reactance to resistance ( $Q$ ) is large and either series or parallel circuit arrangements may be used. Depending upon whether series or parallel resonance is used, the detector will either be an ammeter or a voltmeter. In either case the unknown may be measured by varying either frequency, resistance or reactance (usually capacitance). Frequency variation may be less desirable for high-accuracy requirements because the voltage (or current) versus frequency response of the circuit may not be symmetrical about the resonant frequency, thereby introducing errors. Resonance methods primarily determine circuit parameters rather than the parameters of an individual component. Determinations of the resistance and reactance, or conductance and susceptance of a particular component can only be made when the other circuit elements are known or their contribution to the circuit response is determined to be of no significance. Resonance methods are not suitable for three-terminal measurements or "in situ" measurements, and should not be used at frequencies where any individual circuit component is near its self-resonant frequency.

## b. Series Resonance:

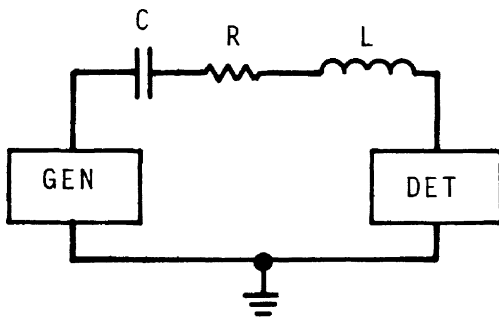

Figure 3-6a. Series resonant circuit

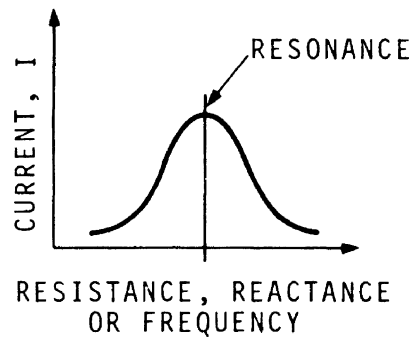

Figure 3-6b. Response of series resonant circuit

Either a resistance variation, a reactance variation or a frequency variation scheme may be used. In all cases:  $\omega L = 1/\omega C$ .

For resistance variation:

$$R_s = \frac{1}{\frac{I_{r_1}}{I_{r_2}} - 1} R \quad (3-3)$$

Here the frequency and voltage are held constant during the measurement. The standard resistance,  $R$ , is inserted in, and removed from, the circuit and the current levels  $I_{r_1}$  and  $I_{r_2}$  observed so that eq. (3-3) gives the value of the resistance,  $R_s$ , of the series resonant circuit.

For reactance variation:

$$R_s = \frac{\omega(L - L_r)}{\sqrt{\left(\frac{I_r}{I}\right)^2 - 1}} \quad (3-4)$$

In this case the frequency  $\omega$ , and voltage are held constant during the measurement and the values of inductance  $L$ , and  $L_r$ , (these could also be capacitances) are noted which give current values of  $I$ , and  $I_r$  respectively.

For frequency variation:

$$R_s = \frac{L(\omega - \omega_r)}{\sqrt{\left(\frac{I_r}{I}\right)^2 - 1}} \quad (3-5)$$

This method is the same as the reactance variation method with the exception that the frequency,  $\omega$ , is the variable quantity. In eq. (3-4) through (3-6) the subscript  $r$  denotes values at resonance.

Series resonant techniques have some rather serious disadvantages and are not often used. The fact that all elements are in series and thereby do not share a common ground increases the liability

of error due to undefined circuit residuals. A reliable, stable and highly sensitive current detector(ammeter) is a difficult requirement to fulfill especially at high frequencies. Ideally, of course, the ammeter should have zero impedance. Resistance, reactance and frequency variation techniques are all equally valid with series resonant methods, but there are some outstanding disadvantages in each instance. Reactance variation using a variable capacitor has the fewest drawbacks because of the relative purity, high quality and availability of variable capacitors. Variable resistors of infinite resolution, low and constant reactance and low temperature coefficient are not easily procured making the resistance variation method subject to larger errors. Frequency variation also places very stringent requirements on the signal source. It not only must be tunable, but must also be highly stable in both frequency and output level and have relatively high power output capabilities in order for high accuracy measurements to be obtained.

References on Series Resonance see [3, 69].

c. Parallel Resonance:

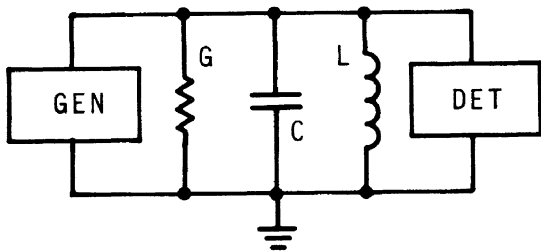

Figure 3-7a. Parallel resonant circuit

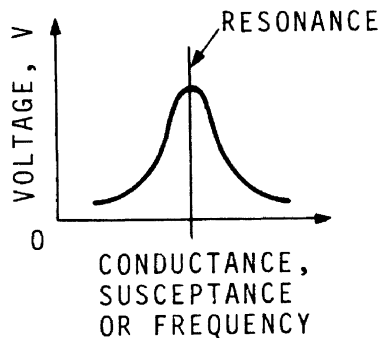

Figure 3-7b. Response of parallel resonant circuit

Either a conductance variation, a susceptance variation or a frequency variation scheme may be used. In all cases:

$$\omega L = 1/\omega C \tag{3-6}$$



For conductance variation:

$$G_p = \frac{1}{\frac{V_{r1}}{V_{r2}} - 1} G \quad (3-7)$$

Here the frequency and current are held constant during the measurement. Voltages  $V_{r1}$  and  $V_{r2}$  are observed with the standard conductance,  $G$ , in and out of the circuit.  $G_p$  is the conductance of the parallel resonant circuit.

For susceptance variation:

$$G_p = \frac{\omega(C - C_r)}{\sqrt{\left(\frac{V_r}{V}\right)^2 - 1}} \quad (3-8)$$

In this case the frequency,  $\omega$ , and current are held constant and the capacitance values,  $C$  and  $C_r$  are noted which give voltages of  $V$  and  $V_r$  respectively.

For frequency variation:

$$G_p = \frac{C(\omega - \omega_r)}{\sqrt{\left(\frac{V_r}{V}\right)^2 - 1}} \quad (3-9)$$

This method differs from susceptance variation only in that the frequency is the variable quantity instead of capacitance. In eqs.(3-7) through (3-9) the subscript,  $r$ , indicates values at resonances.

Parallel resonance methods find application in the measurement of dielectric constant and loss tangent or conductance of dielectric materials. Parallel arrangement of circuit elements is easier to implement and introduces fewer errors because each circuit element shares a common ground. High impedance detectors with good sensitivity which do not introduce significant circuit loading are available.

The frequency variation method has been used at high frequencies (up to 100 MHz) and involves the measurement of  $Q$  by the technique of varying the frequency on each side of the resonance voltage peak,  $V_r$ , until the voltage seen by the detector falls to  $\sqrt{2}/2 V_r$ , the half-power points.  $Q$  is then given by  $f/\Delta f$ , where  $f_r$  is the resonant frequency and  $\Delta f$  is the difference in frequency between upper and lower half-power points. A 3 dB attenuator can be used for the initial  $V_r$  setting and then removed, thereby increasing  $V_r$  by 3 dB. The circuit is then detuned in frequency to the original  $V_r$  value. A similar procedure can be used with capacitance as the variable quantity in which case  $Q$  is given by  $C_r/\Delta C$ . See references [6] and [14].

d. Resonance Methods For Determining Residual Impedances:

The following two paragraphs describe useful measurement techniques which utilize the resonance method to determine the residual impedances associated with capacitors and inductors.

- (1) Grid Dip Meter: (for determining the residual inductance of capacitors)

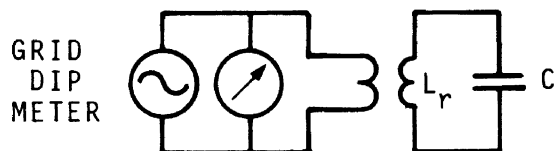

Figure 3-8. Grid dip meter application

In high Q circuits a grid dip meter may be used for determining either inductance or capacitance where two reactive elements are connected in parallel as shown in figure 3-8. The coil of the grid dip meter is loosely coupled inductively to the circuit and the frequency of the grid dip meter is varied until a dip occurs. This locates the resonant frequency of the circuit and either L or C is then calculable from the resonant relationship  $\omega L = 1/\omega C$  provided the other parameter is known. This method is useful for measuring the inductance of capacitors and with care can yield inductance values accurate to well within  $\pm 10\%$ . The use of a heterodyne frequency meter as a frequency counter and corrections for the value of the shorting inductance increase the accuracy of the results. See references [3, & 15].

- (2) Three Frequency Method (for determining the residual capacitance of inductors)

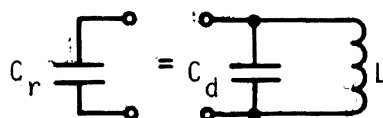

Figure 3-9. Three frequency method, equivalent method

It is occasionally necessary that the distributed or residual capacitance of an inductor be measured, and this can be accomplished to a reasonable accuracy,  $\pm 10\%$ , by measuring the capacitance required to resonate the inductor at three different frequencies. A Q-meter is usually the most appropriate instrument for the purpose although a grid dip meter and three capacitors of known value could also be used. For best accuracy, the frequencies must be sufficiently far from the self-resonance of the coil so that  $1/\omega_r^2$  is approximately linear with capacitance. This can be assured by measurements at three frequencies instead of two. By plotting  $1/\omega_r^2$  versus  $C_r$  on linear graph

paper, a straight line will result, and the equation for the

line is 
$$C_r = (1/L_t)(1/\omega_r^2) - C_d \tag{3-10}$$

where  $C_r$  = the capacitance in Farads necessary to resonate the inductor at the angular frequency  $\omega_r$  rad/sec.

$L_t$  = the true inductance of the inductor in henrys

$C_d$  = the distributed capacitance of the coil in Farads.

Equation (3-10) is of the form  $y = mx+b$  which is the slope-intercept form of the equation for a straight line where the slope is  $1/L_t$  and the y intercept is  $C_d$ . See reference [3] or [19].

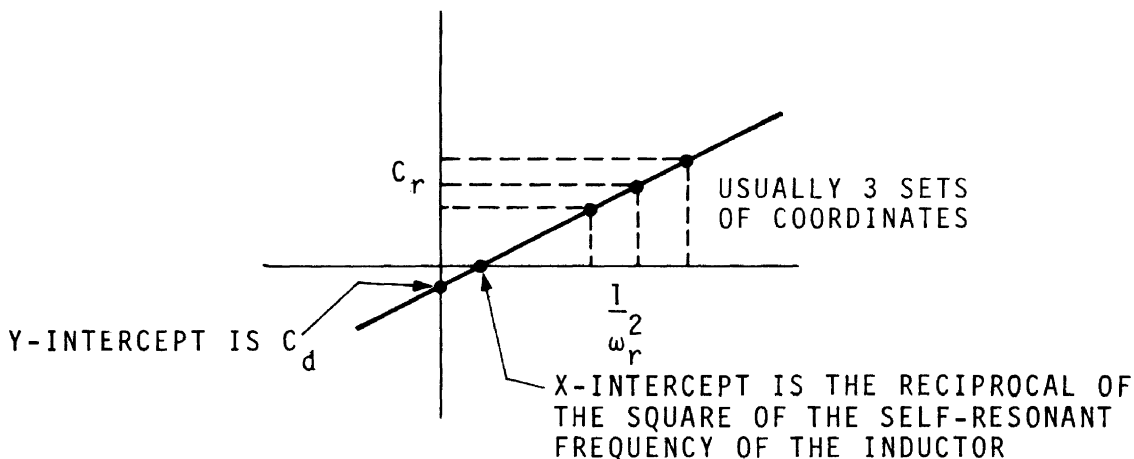

Figure 3-10. Three frequency method, data analysis

Resonance methods offer a distinct advantage in resolving small losses in the presence of large reactance (high-Q components) because Q may be resolved to two or three significant figures. This is in contrast to bridges where the resistance dial calibration near the zero setting may be rather coarse and provide no more than a one significant figure readout.

For details on the derivations of the equations of resonance methods, see especially reference [4].

#### e. Error Sources

The following are some of the more important sources of error occurring in resonance measurements:

(1) Frequency inaccuracy or instability during the measurement procedure

(2) Generator voltage level instability

(3) If an element of the resonant circuit is nonlinear with frequency or power level it will produce an unsymmetrical detector response and result in erroneous measurements. (See fig. 3-6b and fig. 3-7b).

(4) In any resonance measurement it is very difficult to separate the resistance of the measured component from the resistance of the remainder of the resonant circuit. This causes the percentage error in  $Q$  to increase as the measured  $Q$  becomes larger. (In other words the optimum accuracy for measuring  $Q$  is obtained for  $Q = 1$  with the uncertainty increasing as  $Q$  becomes either larger or smaller)

(5) Non-precision connectors at the measurement interface between instrument and unknown contribute significant uncertainties especially to the measurement of very large or very small reactances.

#### f. Strengths and Weaknesses of Resonance Methods

##### Strengths:

(1) Good for high- $Q$  measurements

(2) Fast compared to null methods (when  $Q$ -meter is being used)

(3) Broad frequency range

(4) Easy to use with external standards for extending impedance range

(5) Versatile in that frequency is easy to vary in the measurement procedure

- (6) Calibration less difficult than for most null instruments
- (7) Good resolution of minor component in high-Q impedances

**Weaknesses :**

- (1) Not usable for low-Q measurements
- (2) Accuracy generally not as good as null method in impedance ranges where the two methods have overlapping capabilities
- (3) Frequency must be closely controlled to avoid large errors
- (4) Operator experience is essential for good results and to avoid instrument damage
- (5) Reactance range is relatively narrow at a given frequency when compared to null instruments (this is especially true for Q-meters)
- (6) Residual circuit losses introduce large errors in measurement of high-Q values

Other references: [5, 8, 9, 10, 11, 12, 13, 14, 15, 19, 68]

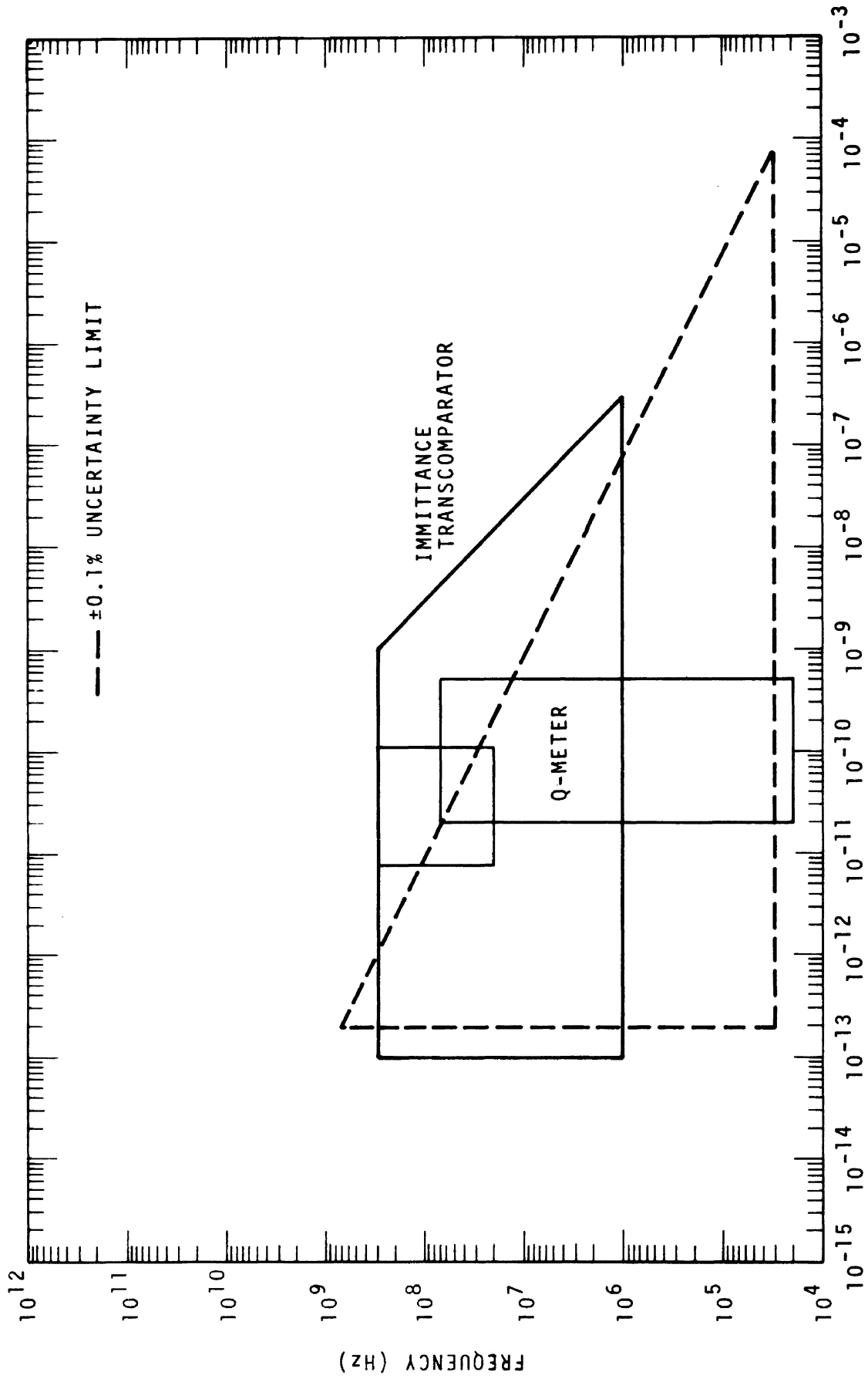

Figure 3-11. Resonance methods for two-terminal capacitance measurement: Instruments and their approximate ranges.

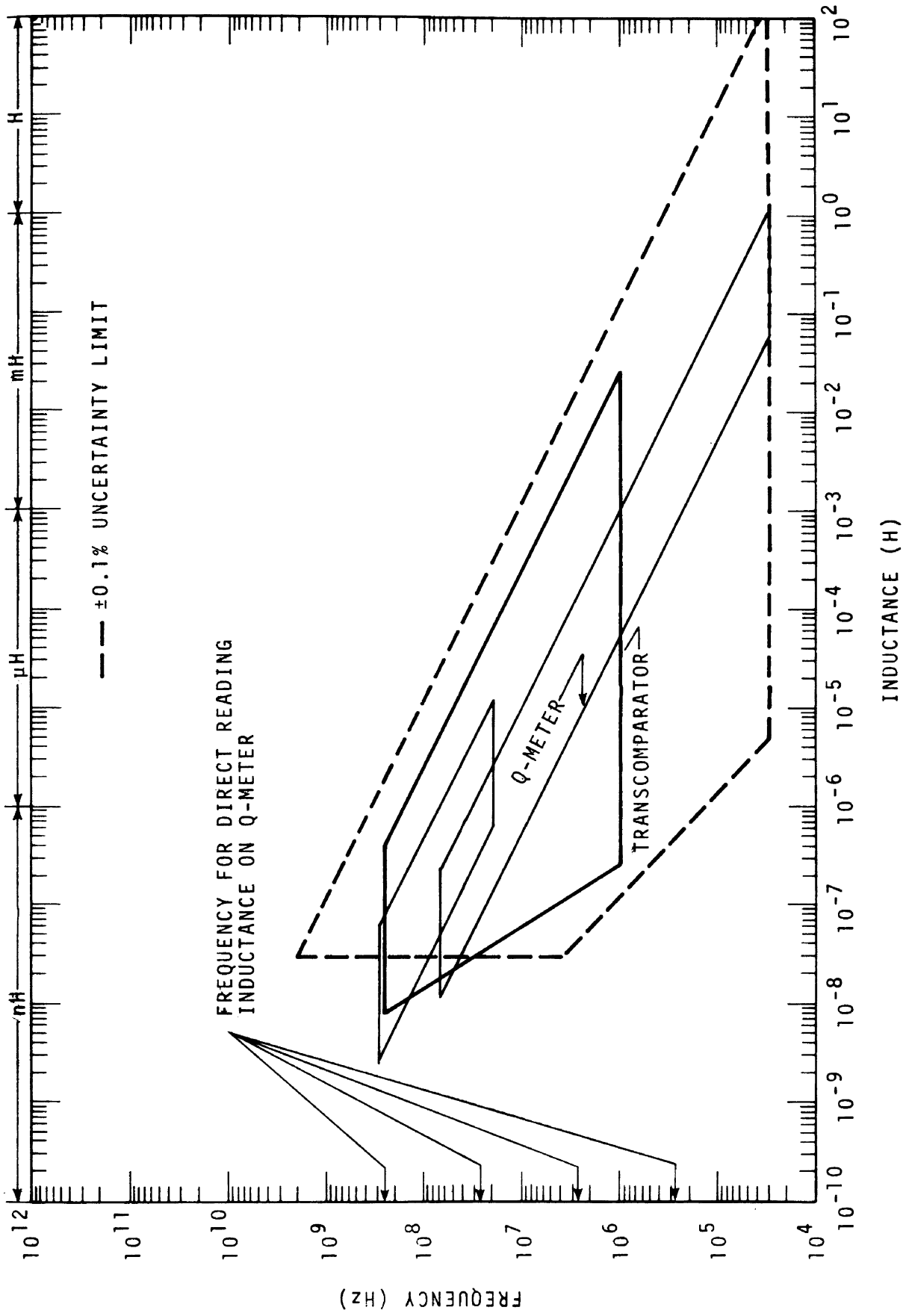

Figure 3-12. Resonance methods for two-terminal inductance measurement: Instruments and their approximate ranges in frequency and magnitude.



### 3.4. Active Methods

Categories Measured: All

#### a. General Comments

The active definition of impedance is, by ohms law, the ratio of complex voltage to complex current

$$\bar{Z} = \bar{V}/\bar{I} \quad (3-11)$$

Following this definition, active methods of impedance measurement are defined or distinguished as being those which measure the ratio of complex voltage to complex current.

Expanding the above equation:

$$\bar{Z} = |Z| \angle \theta = \frac{|V| \angle \phi_V}{|I| \angle \phi_I} = \frac{|V|}{|I|} \angle \phi_V - \angle \phi_I \quad (3-12)$$

where  $|Z|$ ,  $|V|$ ,  $|I|$  are absolute magnitudes and  $\theta$ ,  $\phi_V$ ,  $\phi_I$  are the phase angles of impedance, voltage and current respectively.

#### b. Vector Impedance Meters

Many different schemes have been devised which embody the active method with the vector impedance meter being the one most often encountered, and all have basic and common characteristics. A source of energy, either current or voltage, is impressed across the unknown impedance and the resulting voltage drop is measured by a voltmeter which may be calibrated to read directly in impedance magnitude. In addition some means must be provided whereby the phase of the detected voltage is compared to the phase of the input signal and the difference displayed. These concepts are illustrated by the following diagrams.

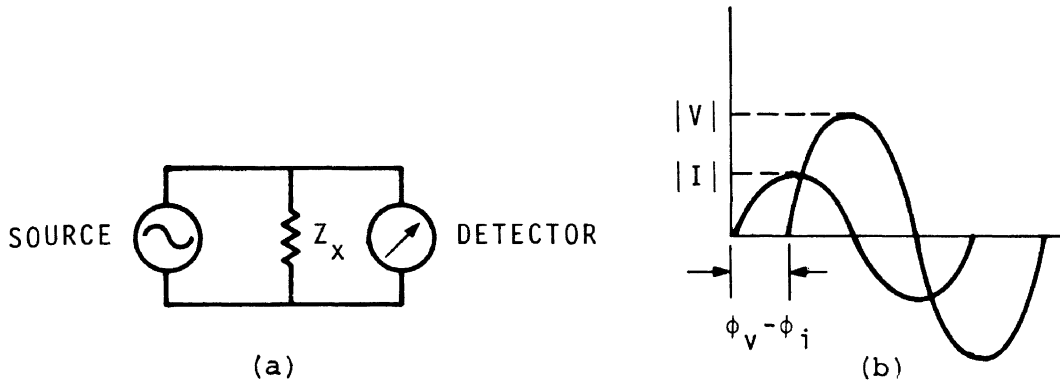

Figure 3-13. Active method for measuring impedance

The impedance magnitude is the ratio of the magnitudes of the voltage and the current and the impedance phase-angle is the phase difference between the voltage and the current. The principle is quite simple, but the instrumentation necessary to accomplish it can become rather complicated and elaborate especially as accuracy requirements and measurement frequencies are increased.

For measuring small impedances, a constant current generator is required and for measuring large impedances, a constant voltage generator is ideal and practical. To examine this more closely consider the following diagram

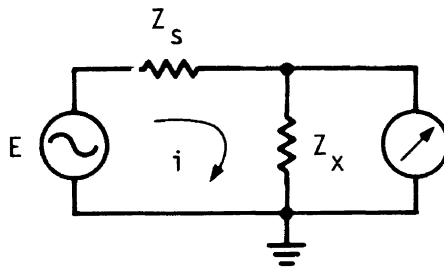

Figure 3-14. Measurement of small impedances using constant current generator

where a large impedance,  $Z_s$ , is placed in series with the oscillator. As long as the unknown impedance  $Z_x$ , is much smaller than  $Z_s$ , then the current,  $i$ , will remain essentially constant, and the measurement can be made accurately. However, when the measurement of large values of  $Z_x$  is required, it becomes necessary to alter this circuit arrangement to provide a constant voltage source as shown in the next diagram, where the large series impedance,  $Z_s$ , is replaced by a small shunt impedance,  $Z_p$ . Under these conditions large values of  $Z_x$

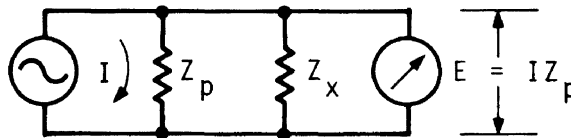

Figure 3-15. Measurement of large impedances using constant voltage generator

do not seriously alter the generator voltage, and the measurement error can be kept small. Through the proper selection of circuit parameters and source voltages, the detector can be calibrated to read directly in impedance magnitude, regardless of whether the source is operated on a constant current or a constant voltage principle.

### c. L-C Meters

To perform phase measurement there is also a variety of available methods, and these too require either a constant current or constant voltage source in accordance with the magnitude of the unknown impedance. Measurements on inductors and capacitors may be made directly at angular frequencies which are integral powers of ten. For example, if the source

is a constant current generator, the voltage,  $E$ , across an unknown inductor,  $L$ , is given by

$$E = I \omega L \quad (3-13)$$

where  $\omega = 2\pi f$  radians/second. In a similar manner capacitance measurements are made possible by the use of a constant voltage source and the relationship

$$I = E \omega C . \quad (3-14)$$

In general such methods as illustrated by equations (3-13) and (3-14) are usable only at lower frequencies, although useful measurements are possible somewhat above the audio frequency region provided sufficient source voltages and/or adequately sensitive voltmeters are available.

#### d. 6-Port Coupler

The six port coupler may take a number of forms, but basically it is an arrangement of hybrid junctions and directional couplers. It provides a unique and highly versatile measurement system with the capability of measuring several electrical parameters over wide ranges. The parameters it can measure include impedance, voltage, current, power and phase.

The voltage  $V$  and the current  $i$  in a transmission line are related to the complex amplitude,  $a$ , of the incident voltage wave and the complex amplitude,  $b$ , of the emergent voltage wave by the diagrams shown in figure 3-16, where  $Z_0$  is the real characteristic impedance of the line at the reference plane.

Measuring the magnitude of any 3 of the 4 vectors (complex numbers)  $v$ ,  $iz_0$ ,  $a$ , and  $b$  completely determines all parts of the parallelogram including phase angles. Phase angles are calculated using the law of cosines. If the magnitudes of all four vectors are measured, the sensitivity in measuring angles near  $0$  and  $180^\circ$  is greatly increased, many calculations are simplified, and the resulting redundancy provides a check on the measurement accuracy.

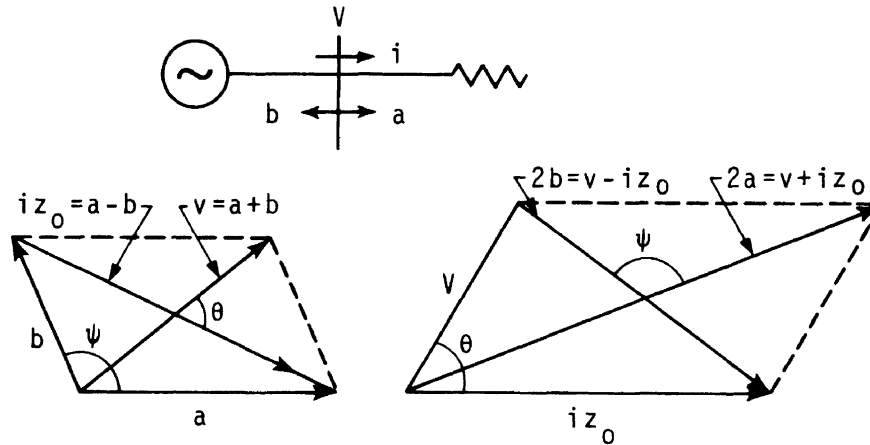

Figure 3-16. Impedance measurement using the 6-port coupler: Relation between voltage ( $v$ ), current ( $i$ ), incident voltage wave ( $a$ ) and reflected voltage wave ( $b$ )

#### e. Error Sources

Active methods in general are not capable of the high accuracies that can be obtained by other methods, but it is also worth noting that active methods are the newest additions and a great deal of innovation and improvement can be expected. Chief error sources are the following:

References on active methods: [57, 71, 6]

Reference on 6-port coupler: [71].

(1) Inability to locate the measurement interface between the measuring instrument and the unknown. This is especially true where probes are used at high frequencies and it becomes very uncertain as to what is actually being measured and the meaning of the results. (The 6-port coupler is an exception to this limitation)

(2) Meter resolution

#### f. Strengths and Weaknesses

##### Strengths:

- (1) Fast
- (2) Operator experience relatively unimportant (except for 6-port coupler)
- (3) Broad frequency ranges available in some instruments
- (4) No calculations required (except for 6-port coupler)
- (5) Often adapted for use with automatic data-processing equipment
- (6) Broad impedance measurement range
- (7) Instruments are commercially available (except for 6-port coupler)

##### Weaknesses:

- (1) Low accuracy
- (2) Frequency range must be sacrificed to obtain accuracy comparable to null instruments
- (3) Measurements very difficult to verify in terms of high-quality impedance standards, especially at high frequencies. Measurement reference plane not well defined (except for 6-port coupler)

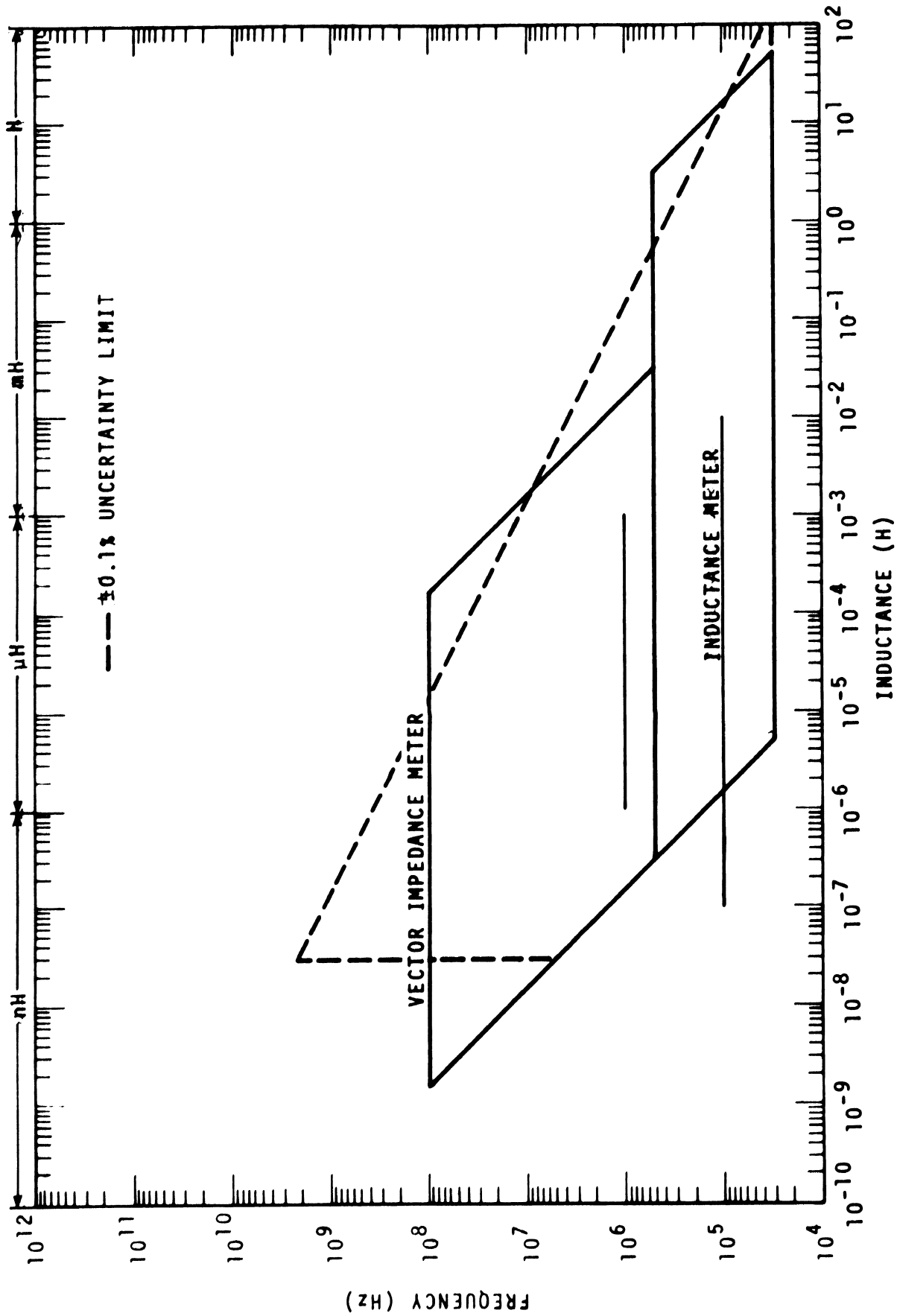

Figure 3-17. Active methods for two-terminal inductance measurement: Instruments and their approximate ranges in frequency and magnitude.

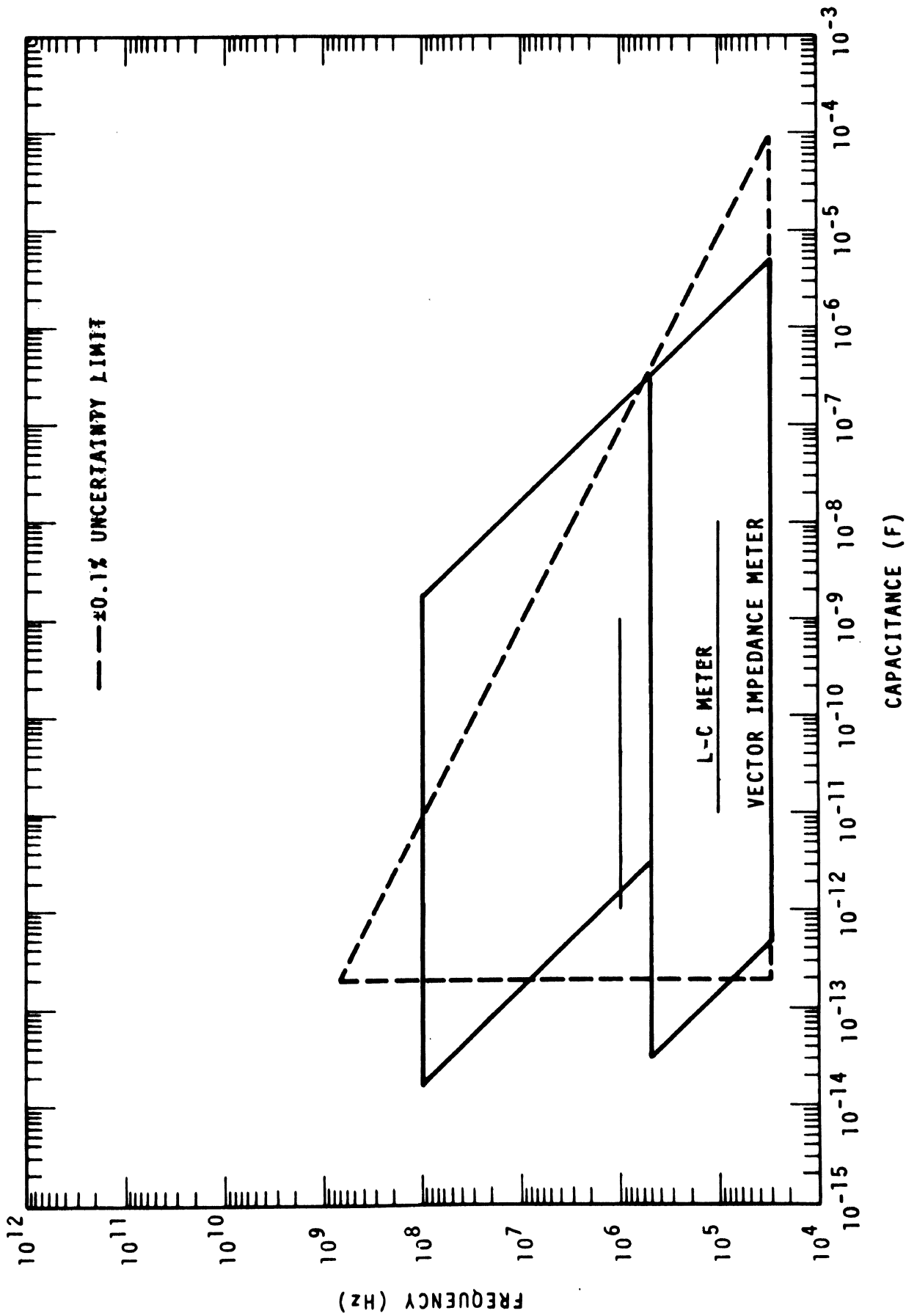

Figure 3-18. Active methods for two-terminal capacitance measurement: Instruments and their approximate ranges in frequency and magnitude.



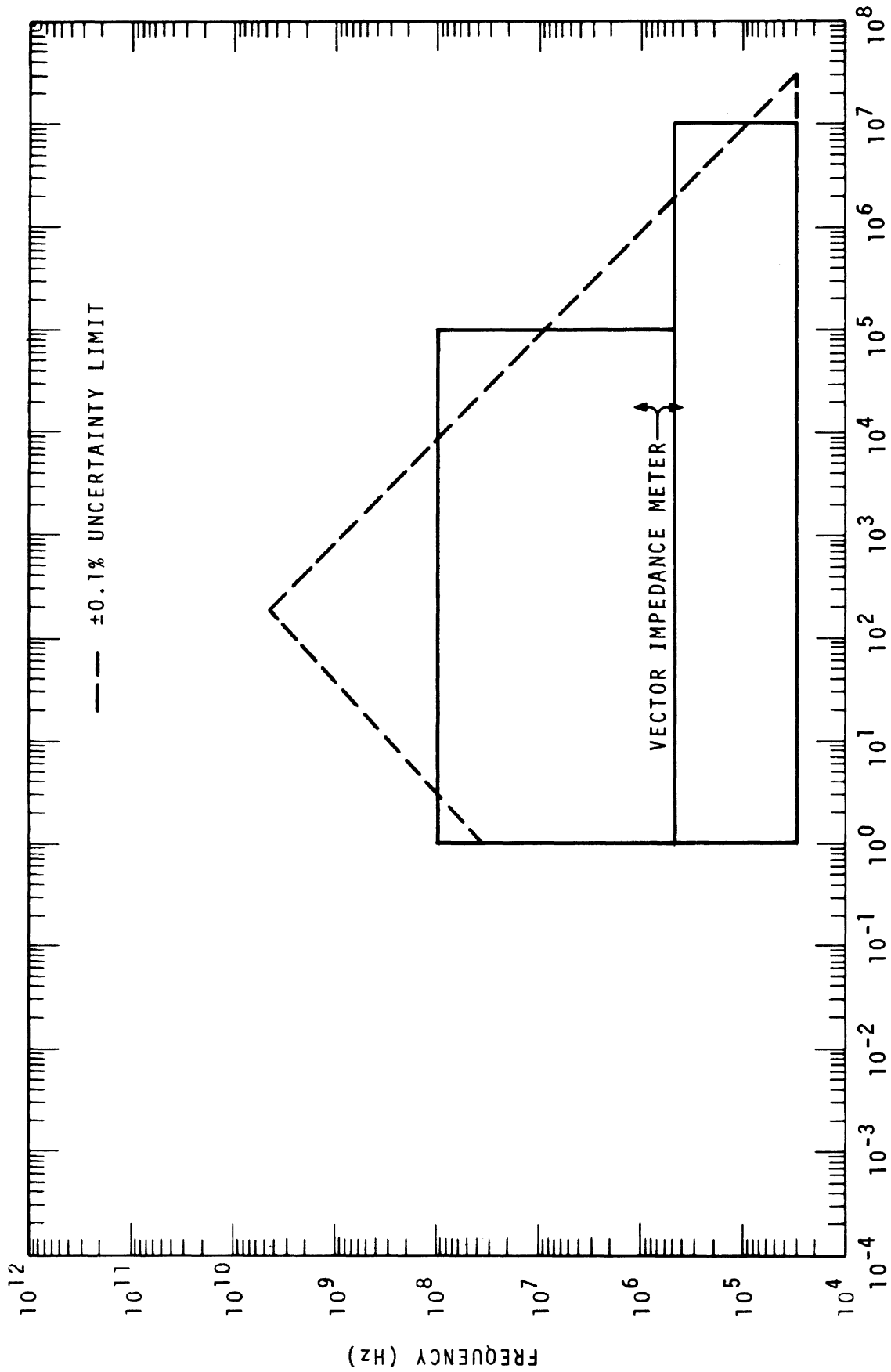

Figure 3-19. Active methods for two-terminal resistance measurement: Instruments and their approximate ranges in frequency and magnitude.

### 3.5. Comparators or Differential Measurements

Categories Measured: All

The measurement of impedance by comparison may involve null methods, resonance methods, or active methods and thereby is not distinguishable as a different measurement method. It is included here because the approach offers some unique advantages, and also because it is widely used. Comparator measurements are of most value where it is necessary to measure a large number of nearly identical items, quickly and accurately.

The comparator approach may utilize any impedance instrument such as a bridge or a meter capable of resolving small differences between a standard and an unknown. This means that the instrument should be both sensitive and stable, but it does not mean that it must be capable of high absolute accuracy. Often it is found that an instrument in the  $\pm 5$  percent accuracy class, together with a good standard, is capable of producing  $\pm 0.1$  percent measurements. For this reason comparator techniques may be extensively used in standards and calibration laboratories. The comparator concept may be illustrated by the equation

$$Z_x = Z_s \pm \Delta Z \quad (3-15)$$

where the value of the unknown,  $Z_x$ , is equal to the value of the standard,  $Z_s$ , plus or minus some small increment,  $\Delta Z$ , observed on the instrument serving as the comparator.

Listed below are some of the main advantages and disadvantages associated with comparator measurements.

Advantages:

- (1) High precision and high accuracy (little effect from large systematic errors)
- (2) Speed and economy (measurements can be made quickly by unskilled personnel)

- (3) High-accuracy instrumentation not required (only stability and sensitivity are needed)
- (4) Excellent for production, quality control and calibration lab applications, sorting of components within tolerance limits, go-no-go testing

Disadvantages:

- (1) Low versatility usually capable of measurements only for specific values, specific types of components and specific frequencies)
- (2) Different standards required for each additional measurement application

References pertaining to Comparator methods: [16, 17]

### 3.6. Automated Measurements

A great deal of emphasis has been devoted to the automation of all types of measurement. Automated instrumentation can greatly reduce measurement time and make possible the accumulation of large amounts of data which would otherwise be impractical. Also, measurement data is made available in digital form for fast processing, and inexperienced personnel may be used so that very little training is required. In lumped parameter impedance measurement, automation has come into extensive use in several ways.

At the lower frequencies (around 10 kHz and below) a number of bridges have been manufactured which fully automate the measurement procedure for resistance, inductance and capacitance. These may be found very valuable for inspection or quality control purposes where measurements at lower frequencies may be used to monitor the behavior of devices whose values are either not frequency dependent or where a highly predictable correction factor may be applied to give higher frequency values. It is not always necessary to perform measurements on components at the exact frequency where they are to be used so long as the values bear a predictable difference between the frequency of measurement and the frequency of application.

At intermediate frequencies (mainly 100 kHz and 1 MHz) automated bridges are available and most are for the measurement of capacitance and either dissipation factor or conductance. These bridges may also be used for component selection or quality control in place of measurements at other frequencies. These bridges, as well as those operating at lower frequencies, are self-balancing so that the only requirement of the operator is the attachment of the device to be measured. Balance is reached in a fraction of a second and the value is displayed in the form of an in-line numerical display or through a digital innerface for computer handling of measurement data.

At higher frequencies (100 MHz and above) automated systems appear in the form of network analyzers capable of performing a wide variety of measurements. These are often large systems operating in conjunction with a computer that controls a pre-programmed measurement procedure in addition to processing the data. Such systems are now appearing with operating capabilities down to very low frequencies. Network analyzers can be used in a swept frequency or a stepped frequency operating mode and can also utilize an oscilloscope display for the measurement data. These find extensive use in the analysis of multiport devices, attenuators, filters and various system components where input/output response characteristics and measurements of S parameters, attenuation, and return loss are of interest.

### 3.7. Other Methods

There are a number of ways for obtaining impedance information pertinent in the 30 kHz to 300 MHz range which do not fall under the previous methods but will be briefly described here for the sake of completeness.

- a. Time Domain Reflectometer - This has been described as a closed circuit radar system, and is used mainly in connection with coaxial equipment where a uniform characteristic impedance is of interest. Pulses with very fast rise time are transmitted down a line and when impedances are encountered which are different from the characteristic impedance, energy is reflected back and a scope trace can be made to show, within less than a centimeter, the location of a discontinuity. Information regarding the magnitude of the reflection as well as whether the discontinuity is inductive or capacitive is also determined. Time Domain reflectometry has many uses, among them being the design

References on Time Domain Reflectometry [75, 76]

and construction of adapters, loads and mismatches. The information obtained with a reflectometer is broadband in the sense that it is an integrated response covering frequencies up to about 12 GHz. The resolving power of the reflectometer is dependent upon the rise-time of the transmitted pulses with 30 picoseconds being the approximate limit.

- b. Frequency Domain Reflectometer - With the development of directional couplers which are capable of operating down as low as 1 MHz with directivities of the order of 50 dB for coupling ratios of 30, 40 and 50 dB, the way has opened for the use of frequency domain reflectometers in the lumped parameter region. The approach is much the same as for higher frequency reflectometers and the capabilities and limitations are also very similar. These methods produce only impedance magnitude measurements normalized with respect to the characteristic impedance of the system and the range is typically only for voltage standing wave ratios of about 4. Accuracies of three to five percent are typical. Such devices are also very useful in high power measurements in the 1 to 30 MHz frequency range.
  
- c. Swept Frequency - A very popular method for studying the response characteristics of a circuit or component over a wide frequency band is through the use of swept frequency techniques. For one-port devices a slotted line may be used which is terminated by the one-port. The line is energized by a generator emitting a constantly varying frequency between preset upper and lower limits. A broadband detector attached to the slotted line probe is used to record the voltage response as the frequency changes. Two-port devices such as filters are quickly

Reference for Freq-Domain Reflectometer: [77]

Reference for Swept Freq: [78]

analyzed in this manner by simply placing them between a sweep generator and a broad band detector. X-Y plotters are usually employed to graph the swept frequency response for detailed study.

- d. Slotted Lines - A majority of the impedance measurements made with slotted lines are made above 300 MHz, but much work may also be done at lower frequencies, especially down to 100 MHz. Much lower than this, either the phase angle range becomes too restricted or extremely long lines must be used so that other methods are better. Proper use of a slotted line requires a highly trained person and uncertainties of 1 or 2 percent are typical. Voltage standing wave ratios up to 10 and phase angles from  $-90^\circ$  to  $+90^\circ$  are attainable for frequencies where the length of the slotted line is at least one-quarter wavelength. One unique and interesting application for a slotted line is in the measurement of the residual series inductance of a two-terminal capacitor.
  
- e. Return Loss Bridge - This instrument might be classified as a null method because the measurement process does involve a nulling procedure and the equivalent circuit resembles a Wheatstone bridge. The lowest frequency versions operate down to around 2 MHz with uncertainties in the 2 to 5 percent range. These bridges measure voltage standing wave ratio only and do not provide phase information. Operating range covers a bandwidth of several octaves with some bridges being usable as high as 12.4 GHz. Operating procedures are not complicated and are quickly learned.

References on Slotted Line Measurement: [76, 79]

Reference for Return Loss Bridge [80]

TABLE I. INSTRUMENTS MEASURING EQUIVALENT SERIES IMPEDANCE

<u>Instrument</u>	<u>Frequency Range</u>	<u>In-Phase Component</u>	<u>Quadrature Component</u>	<u>Page</u>
Null Method:				23
Maxwell Bridge <sup>1,2</sup>	10 kHz to 30 kHz	$2 \times 10^{-4}$ to $10^5 \Omega$ ( $\pm 0.25\%$ )	$2 \times 10^{-9}$ to $10^1 H$ ( $\pm 0.25\%$ )	59
Schering Bridge <sup>1,2</sup> (ckt b)	50 kHz to 60 MHz	0 to $10^3 \Omega$ $\pm (1\%)$	$\pm (0 \text{ to } 5 \times 10^3) \text{ ohms}^3$ at 1 MHz ( $\pm 2\%$ )	66
Transformer Ratio <sup>1,2</sup> Bridge	10 kHz to 10 MHz	$10^{-4}$ to $10^8 \Omega$ $\pm (1 \text{ to } 2\%)$	$10^{-11}$ to $10^1 H$ $\pm (1 \text{ to } 2\%)$	75
Active Method:				40
L-C Meter	100 kHz		$10^{-5}$ to $10^{-2} H$ ( $\pm 0.5\%$ )	
	1 MHz		$10^{-6}$ to $10^{-3} H$ ( $\pm 0.5\%$ )	128
Vector Impedance Meter	30 kHz to 500 kHz	<u>Magnitude</u> 1 to $10^7 \Omega$ ( $\pm 5\%$ )	<u>Phase Angle</u> 0 to $\pm 90^\circ$ ( $\pm 6^\circ$ )	122
	500 kHz to 100 MHz	1 to $10^5 \Omega$ ( $\pm 5\%$ )	0 to $\pm 90^\circ$ ( $\pm 3\%$ )	
Byrne Bridge	50 to 500 MHz	2 to $2 \times 10^3 \Omega$ ( $\pm 5\%$ )	0 to $\pm 90^\circ$ ( $\pm 3^\circ$ )	99

<sup>1</sup> Ranges and accuracies do not apply for entire frequency range.

<sup>2</sup> More than one instrument required to cover these ranges.

<sup>3</sup> Range varies inversely as the frequency.



Table I (cont.)

INSTRUMENTS MEASURING EQUIVALENT SERIES IMPEDANCE

<u>Instrument</u>	<u>Frequency Range</u>	<u>Series Resistance</u> ohms	<u>Series Inductance</u> Henrys	<u>Page</u>
5 Null Method: Maxwell Bridge	10 kHz to 30 MHz	$2 \times 10^{-4}$ to $10^5$ $\pm (0.25\%)$	$2 \times 10^{-9}$ to $10^1$ $(\pm 0.25\%)$	59
Schering Bridge ckt(b)	50 kHz to 60 MHz	0.5 to $10^3$ $\pm (1\%)$	0.5 to $5 \times 10^3$ ohms at 1 MHz ( $\pm 2\%$ )	66

TABLE II. INSTRUMENTS MEASURING EQUIVALENT PARALLEL ADMITTANCE

<u>Instrument</u>	<u>Frequency Range</u>	<u>In-Phase Component</u>	<u>Quadrature Component</u>	<u>Page</u>
Null Method: Schering Bridge ckt (a)	500 kHz to 250 MHz	15 to $10^5 \Omega$ ( $\pm 2\%$ )	$+20 \times 10^{-12}$ to $-10^{-10}$ F ( $\pm 0.5\%$ )	64
Admittance Ratio Bridge	10 kHz to 5 MHz	0 to $10^{-3}$ S ( $\pm 5\%$ )	$0.1 \times 10^{-12}$ to $1.1 \times 10^{-9}$ F ( $\pm 0.25\%$ )	70
Transformer Ratio <sup>1,2</sup> Bridge	10 kHz to 100 MHz	$10^{-8}$ to $10^4$ S $\pm (1$ to $2\%)$	$10^{-13}$ to $10^{-5}$ F $\pm (1$ to $2\%)$	75
Twin-T <sup>1</sup> Bridge	10 kHz to 5 MHz	$10^3$ to $5 \times 10^7 \Omega^3$ ( $\pm 0.1\%$ )	$\pm (0.1 \times 10^{-12}$ to $5 \times 10^{-9}$ F ( $\pm 0.1\%$ )	82
Thurston Bridge	5 MHz to 250 MHz	20 to $3 \times 10^5 \Omega$ ( $\pm 0.1\%$ )	$\pm (0.1 \times 10^{-12}$ to $5 \times 10^{-11}$ F) ( $\pm 0.1\%$ )	88
Young Bridge (3-terminal)	40 MHz to 1.5 GHz	$10^{-5}$ to 4 S ( $\pm 3\%$ )	$\pm 10^{-5}$ to 4 S <sup>3</sup> ( $\pm 3\%$ )	94
Resonance Method:	100 kHz to 1 MHz	$10^{-8}$ to 1 S ( $\pm 10\%$ )	$2 \times 10^{-17}$ to $10^{-9}$ F ( $\pm 0.25\%$ )	29
Q-Meter	20 kHz to 70 MHz	<u>Q</u> 5 to 1000 $\pm (5$ to $15\%)$	<u>Capacitance</u> $20 \times 10^{-12}$ to $500 \times 10^{-12}$ F ( $\pm 1\%$ )	111
	20 MHz to 300 MHz	10 to 1000 $\pm (5$ to $15\%)$	$10 \times 10^{-12}$ to $100 \times 10^{-12}$ F $\pm (1\%)$	

## 4. INSTRUMENTS FOR VARIOUS METHODS

### Introduction

The material presented in this section is intended as an aid in critically comparing various instruments which operate under the methods identified in Section 3. Following the same order of presentation of Section 3, nine instruments are described and evaluated which are of the null variety, three of the resonance variety and two which utilize the active method. The format is also similar, in that specific comments regarding technical characteristics, strengths, weaknesses and graphs of measurement range versus frequency are provided. Most of the instruments discussed are commercially available. However, some are not manufactured for sale and those in existence have been constructed for specific needs by individual laboratories. There is still another group of instruments that should not be overlooked. This group includes those instruments which were once commercially available, but for one reason or another have disappeared from the catalogs of instrument manufacturers. Many of these remain in service, or may be found available in surplus or used equipment inventories. Examples of this group include the Twin-T and the Byrne Bridge. The information on frequency ranges, measurement ranges and uncertainties, is an attempt to generalize what is found in the referenced literature, and in the catalogues of instrument manufacturers. In the upper right hand corner of the initial page describing a particular instrument, an item "categories measured" will be found followed by one or more capitalized letters which allude to the categories identified in Section 2.

4.1. Null Instruments

Categories Measured:

A,C,D,E,G

- a. Maxwell Bridge  
(product arm)

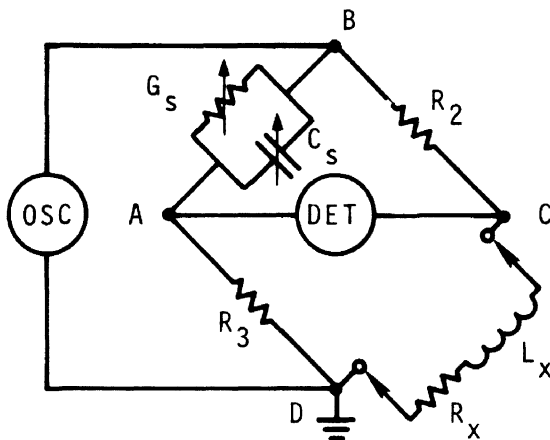

BALANCE EQUATIONS:

$$R_x = R_2 R_3 \Delta G_s \quad (4-1)$$

$$L_x = R_2 R_3 \Delta C_s \quad (4-2)$$

Figure 4-1.

Range and uncertainty for resistance:

0.2 mΩ to 110 kΩ at 30 kHz decreasing to 11 kΩ at 500 kHz and 30 Ω at 30 MHz.

Basic uncertainty of the order of ±3% for unknowns with low Q, and increasing as Q of unknown impedance becomes larger.

Range and uncertainty for inductance:

0.2 nH to 11H at 30 kHz decreasing to 10 mH at 1 MHz and 60  $\mu$ h at 30 MHz.

Basic uncertainty of the order of  $\pm 0.25\%$  at lower frequencies and increasing to  $\pm 5\%$  at higher frequencies.

Comments:

This bridge measures series inductance and series resistance in terms of capacitance standard,  $C_s$ , and conductance standard,  $G_s$ , and is about the only method available for accurately measuring low impedances at high frequencies except for the Schering bridge. Initial balance is made with respect to a short circuit placed at the unknown terminal. A complete calibration of a Maxwell bridge is extremely difficult so that it is best to calibrate or check at spot frequencies and values as needed. Accuracies are very difficult to verify because of different connector configurations at unknown terminals. Internal shielding requirements are stringent, making the circuit impractical for use much above 30 MHz. Most commercial versions have a self-contained oscillator and detector. Resistance and inductance measurements do not contain first order errors due to inaccuracy of oscillator frequency because frequency terms do not appear in balance equations. When measuring large values of inductance, the capacitance from the "C" corner of the bridge to ground becomes an important source of error. These errors also increase with frequency. Measurements made with the Maxwell bridge are relatively slow and operator should be aware of, and know how to minimize, connection errors when attaching the unknown to the bridge. Leads should be kept short, in all cases. Graphs showing frequency and magnitude measurement ranges do not represent any one instrument. Several commercial versions of the Maxwell bridge

are available, of both domestic and foreign manufacture, and there are many areas of overlap in frequency and measurement range.

**Strengths:**

- (1) High Accuracy
- (2) Best of all instruments for measuring small values of series resistance and series inductance
- (3) Commercially available
- (4) Broad measurement range for resistance

**Weaknesses: or Limitations**

- (1) Maximum upper frequency 30 MHz
- (2) Difficult to calibrate
- (3) Slow
- (4) Complex internal shielding requirements make the bridge difficult to construct

Reference pertaining to Maxwell Bridge: [18, 19]

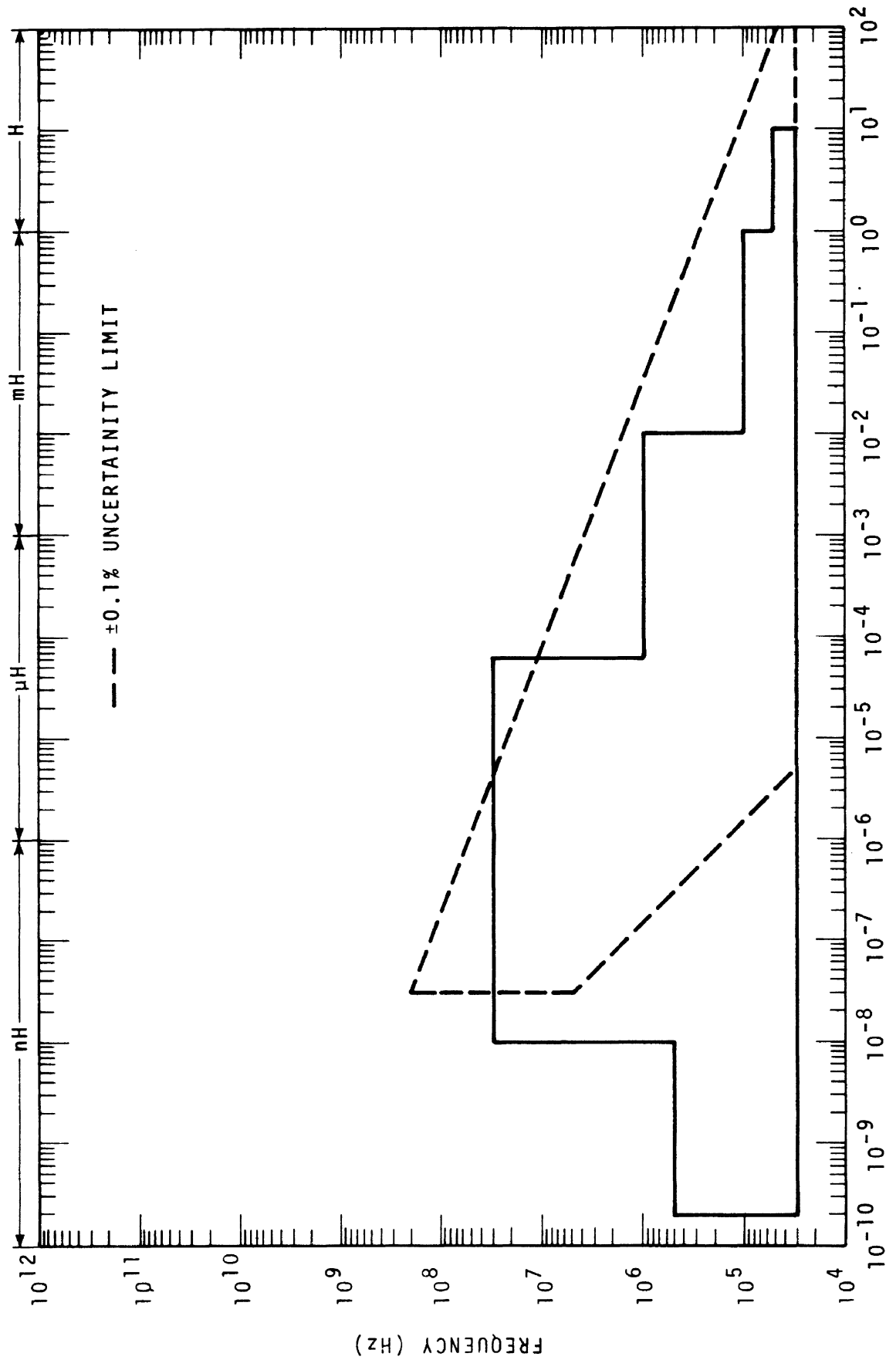

Figure 4-2. Maxwell impedance bridge: Range of inductance vs frequency.

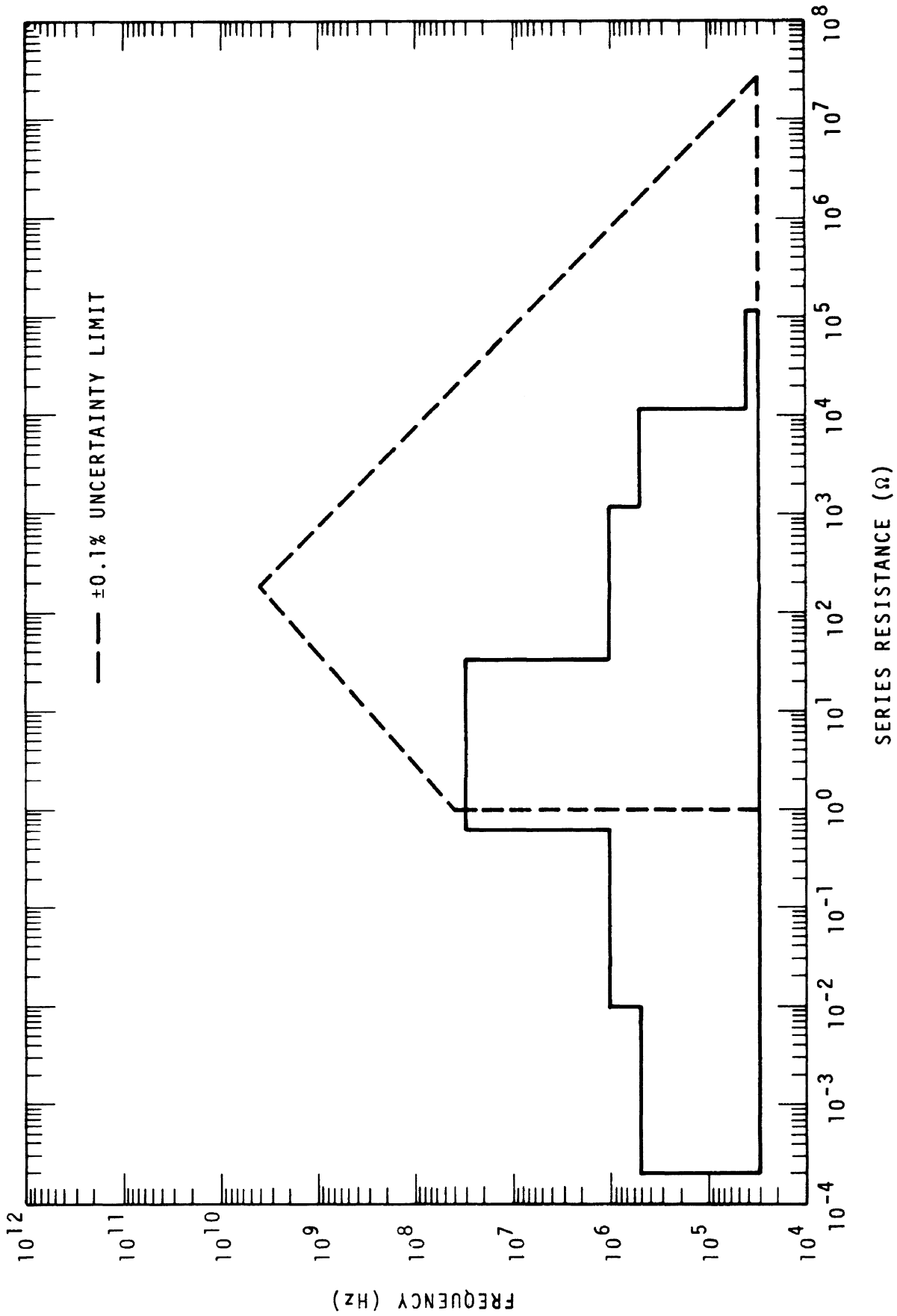

Figure 4-3. Maxwell impedance bridge: Range of resistance vs frequency.



b. Schering Bridge  
(ratio arm bridge)

Categories Measured: A,B,C,D,E

General Comments:

The basic Schering bridge has been modified to perform many specialized measurement functions and in one form or another is probably the most widely used of the rf bridge circuits. This bridge appears in several forms and variations with the two circuits shown above being the ones most frequently encountered. The bridge can be used either for admittance or impedance measurements and in the latter instance will cover ranges which partially overlap the Maxwell bridge. The most nearly ideal standards are variable air capacitors and the main advantage of the Schering bridge is that it employs them as internal standards for both the real and imaginary components of the unknown. Other advantages include small circuit residual impedances permitting operation over wide frequency ranges. Some commercial versions of this bridge contain oscillator and detector and some do not and therefore must be provided. The Schering bridge is often used for measuring components under dc bias conditions.

Circuit(a):

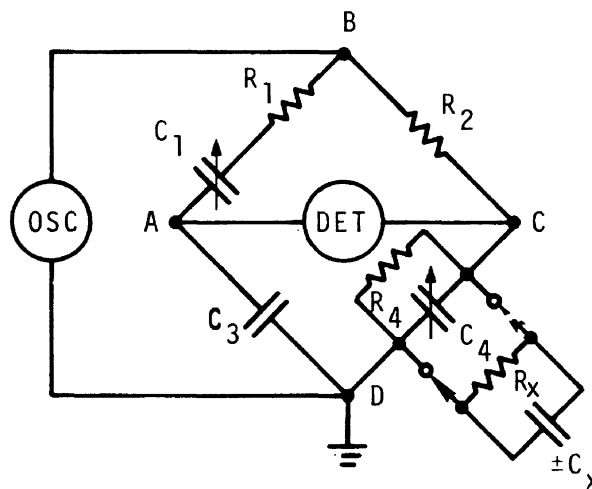

BALANCE EQUATIONS:

$$\frac{R_1}{C_4} = \frac{R_2}{C_3} = \frac{R_4}{C_1} \quad (4-3)$$

$$R_x = \frac{R_2}{C_3} \Delta C_1 \quad (4-4)$$

$$C_x = \Delta C_4 \quad (4-5)$$

Figure 4-4a.

Range and uncertainty for parallel resistance:

15  $\Omega$  to 100 k $\Omega$  from 500 kHz to 250 MHz

Basic uncertainty of the order of  $\pm 2\%$ .

Range and uncertainty for parallel capacitance:

0 to -100 pF or 0 to + 20 pF from 500 kHz to 250 MHz.

Basic uncertainty  $\pm 0.5\%$ .

Comments:

This bridge measures admittance in terms of equivalent parallel resistance and either positive or negative equivalent parallel capacitance, thus either capacitive or inductive impedances can be measured. Balance is made initially with respect to an open-circuit and first order errors due to oscillator frequency are not present. Measurements can be made in a few minutes and no computations are necessary because the readout is direct at all frequencies. Operator skills are important in making proper connections of the unknown to the instrument because improper procedures may seriously degrade the accuracy of the results.

Strengths:

- (1) Broad frequency range
- (2) Broad range for parallel resistance measurement
- (3) Uses variable air capacitors as internal standards for both real and imaginary components
- (4) Good accuracy
- (5) No calculation required
- (6) Commercially available

Weaknesses or Limitations:

- (1) Minimum frequency 500 kHz

- (2) Range for inductance and capacitance measurement small
- (3) Slow
- (4) Not usable below 500 kHz
- (5) Some operator training required

Circuit (b):

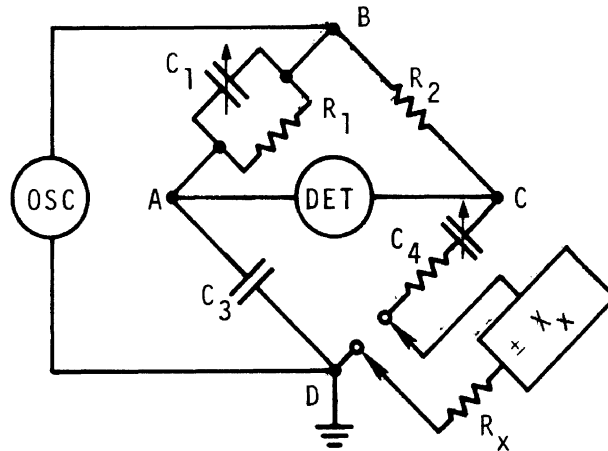

BALANCE EQUATIONS:

$$R_x = \frac{R_2}{C_3} \Delta C_1 \quad (4-6)$$

$$X_x = \frac{1}{\omega} \cdot \frac{1}{\Delta C_4} \quad (4-7)$$

Figure 4-4b.

Range and uncertainty for series resistance:

0 to 1000  $\Omega$  from 50 kHz to 60 MHz. This requires two instruments with overlapping frequency ranges. Basic uncertainty of the order of  $\pm 1\%$

Range and uncertainty for series reactance:

0 to  $\pm 5000 \Omega$  at 1 MHz for one model having a basic uncertainty of  $\pm 2\%$  with range varying inversely as frequency.

Comments:

Although the same basic circuit is used, two instruments have been used to cover the entire frequency range from 50 kHz to 60 MHz. These instruments overlap in frequency range as shown in the graphs for circuit (b). These bridges measure impedance in terms of equivalent series resistance and either positive or negative reactance meaning that either inductive or capacitive unknowns can be measured. Initial balance is made with respect to a short-circuit. Because the readout of the imaginary or quadrature component is in terms of reactance, the measurement accuracy is limited to the accuracy to which the frequency is known. Measurement time is of the order of a few minutes, and operator skill and knowledge are important, especially in making the best connections of the unknown to the bridge.

Strengths:

- (1) Can measure either inductive or capacitive unknowns; readout in terms of reactance
- (2) Uses variable air capacitors as internal standards for both real and imaginary components
- (3) Broad frequency range
- (4) Commercially available
- (5) Good accuracy

Weaknesses or Limitations:

- (1) Good accuracy depends on accurate frequency control
- (2) Usable only up to 60 MHz
- (3) Requires trained operator
- (4) Some calculation required for each measurement

References pertaining to Schering bridge: [19]

circuit (a)	[24,25,26]
circuit (b)	[20,21,22,23]

PARALLEL CONDUCTANCE

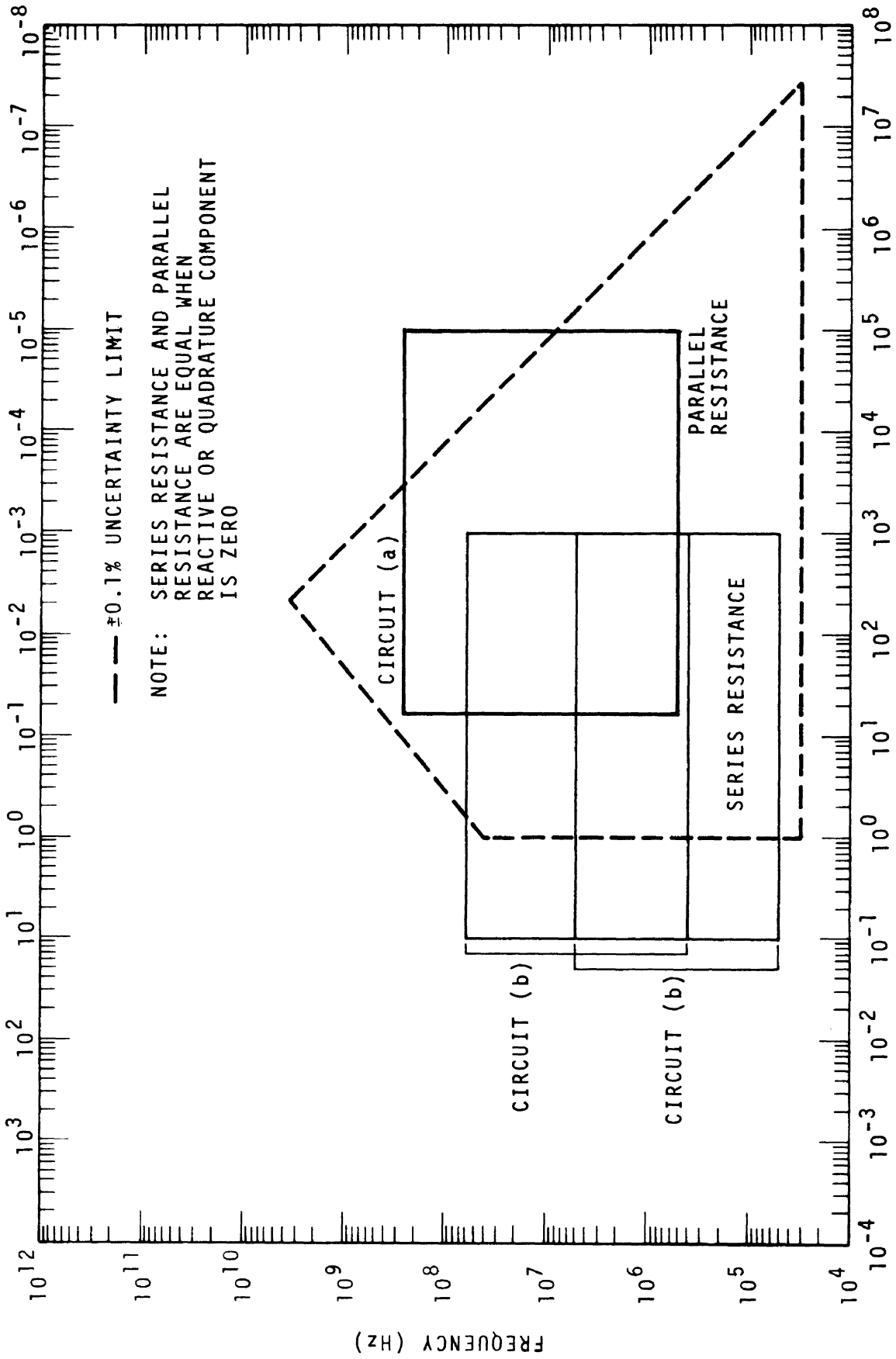

Figure 4-5. Schering bridge: Range of resistance vs frequency .

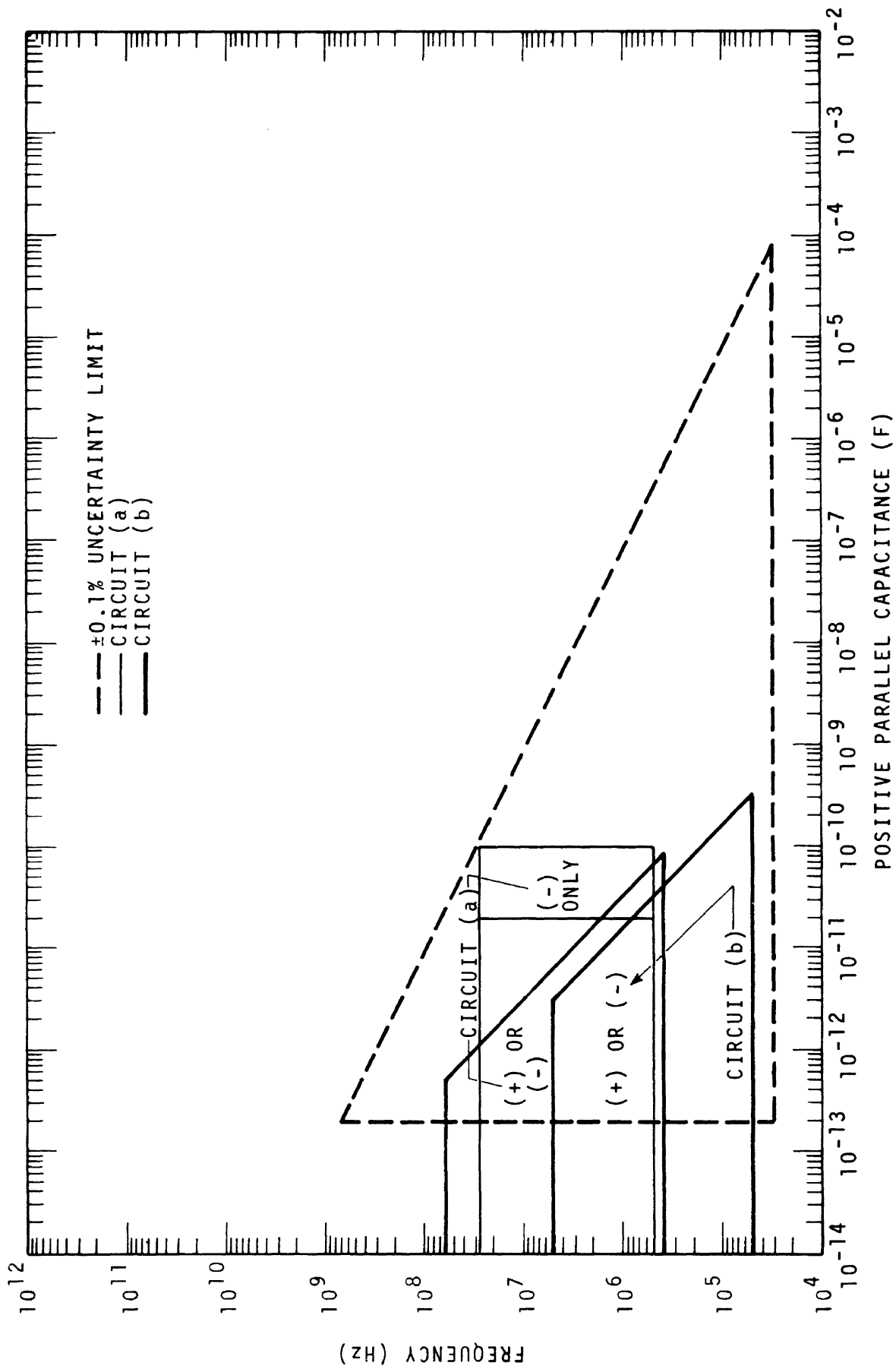
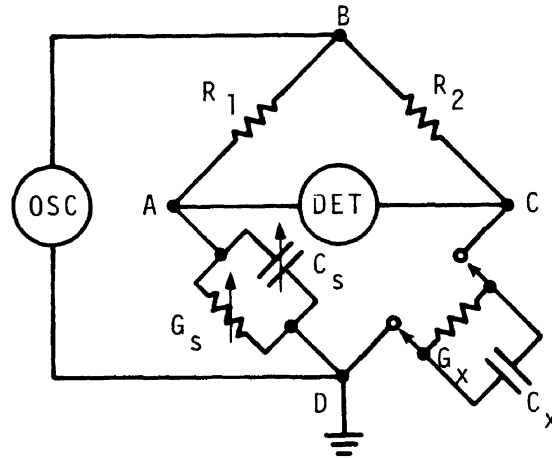

Figure 4-6. Schering bridge: Range of capacitance vs frequency.

c. Admittance Ratio Bridge

Categories Measured:  
D, F, H, B



BALANCE EQUATIONS:

$$G_x = \frac{R_1}{R_2} G_s \quad (4-8)$$

$$C_x = \frac{R_1}{R_2} C_s \quad (4-9)$$

Figure 4-7.

Range and uncertainty for conductance:

0 to 1000  $\mu$ S from 30 kHz to 5 MHz. Range extendable with external standards connected in parallel with standard arm. Basic uncertainty  $\pm 5\%$  at lower frequencies.

Range and uncertainty for capacitance:

0.1 to 1100 pF from 30 kHz to 5 MHz. Range may be extended to 0.1  $\mu$ F with external standards connected in parallel with standard arm. Basic uncertainty  $\pm 0.25\%$  at lower frequencies increasing to  $\pm 1\%$  at 1 MHz and above 1 MHz increasing as square of frequency in MHz. Lower frequency versions operating up to 200 kHz have capacitance capabilities up to 1.11  $\mu$ F.

Comments:

This bridge has its application in the low frequency range and extending upward to 1 MHz. Difficulty in pro-

viding accurate resistive ratio arms having small corrections over a wide frequency range are the main reasons restricting its use at higher frequencies. The basic circuit is usable as a comparator where external standards are available. Initial balance is made with respect to an open-circuit. Readout is in terms of conductance and capacitance, and the unknown is measured directly in terms of internal standards in the adjacent arm of the bridge. External standards added in parallel with the standard arm of the bridge may be used for range extension purposes. Resistors are used as ratio arms providing ratios of 0.1, 1.0, 10 and 100. Errors appear at high frequencies for ratios other than unity because of the effects of reactive residuals in the ratio arms.

A high frequency version of this bridge employing a unity ratio and an electrically symmetrical circuit has been developed for accurate and precise measurements to 20 MHz. See [29].

For the measurement of a wider range of admittances at frequencies up to 200 kHz, both capacitance and conductance standards are provided respectively by capacitors and resistors arranged in a Y-network configuration and connected to the A, C and D corners of the bridge.

This circuit may be used either for capacitance or inductance measurements, but the internal standards must be of the same kind as the unknown to be measured, i.e., the bridge compares like reactances, which is a characteristic of ratio bridges.

Few commercial versions of this bridge are available. Measurements require a few minutes to make with no difficult computations usually required. For maximum accuracy, some rather involved frequency corrections must be used. Good operator skill is desirable.



**Strengths:**

- (1) Wide capacitance range
- (2) Good accuracy capabilities
- (3) Convenient for use with parallel range extension techniques or as a comparator

**Weaknesses or Limitations:**

- (1) Does not measure small impedances
- (2) Generally limited to frequencies below 5 MHz
- (3) Some operator training required
- (4) Few commercial models available

References pertaining to Admittance ratio bridge: [2,17,28,29]

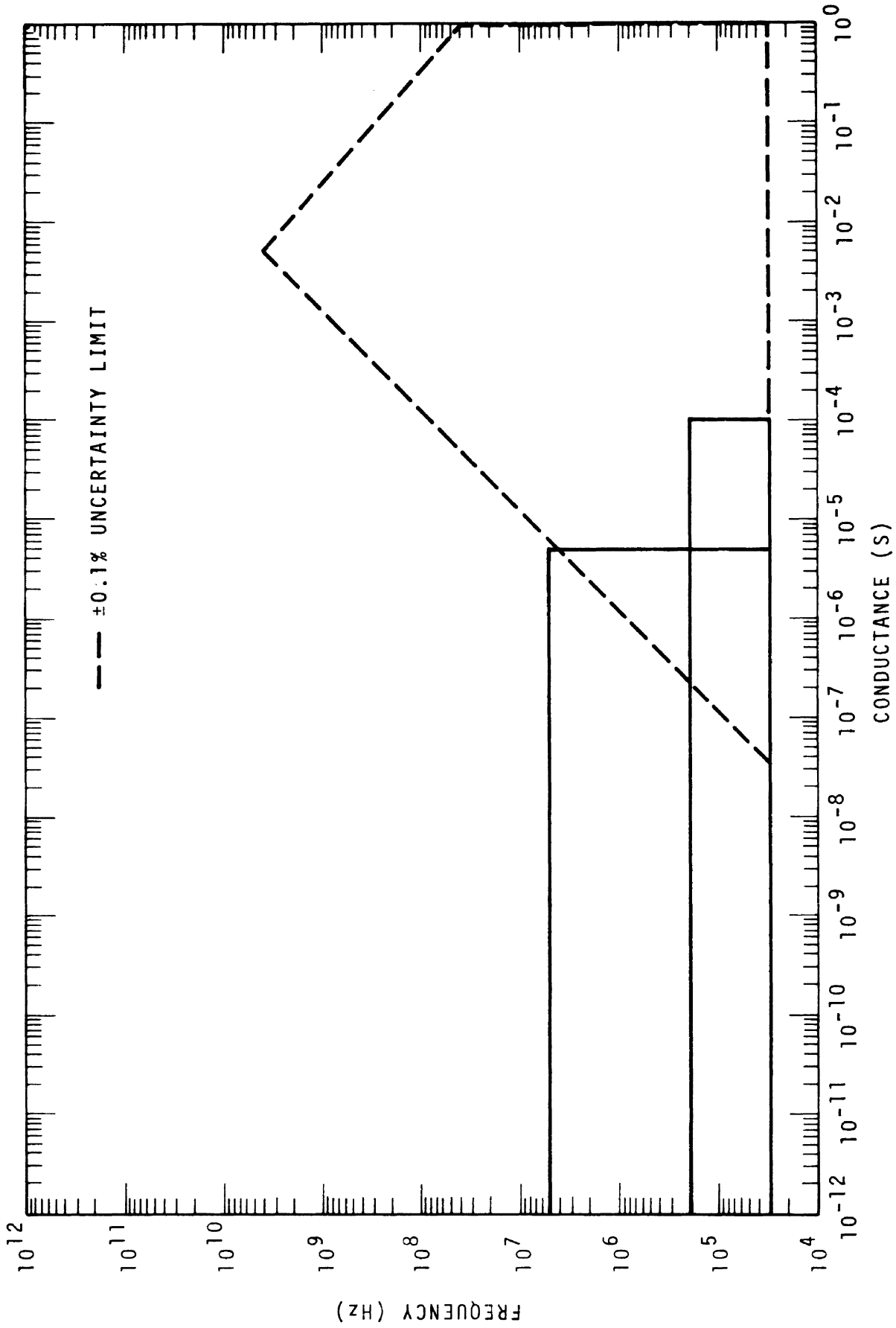

Figure 4-8. Admittance ratio bridge: Range of conductance vs frequency.

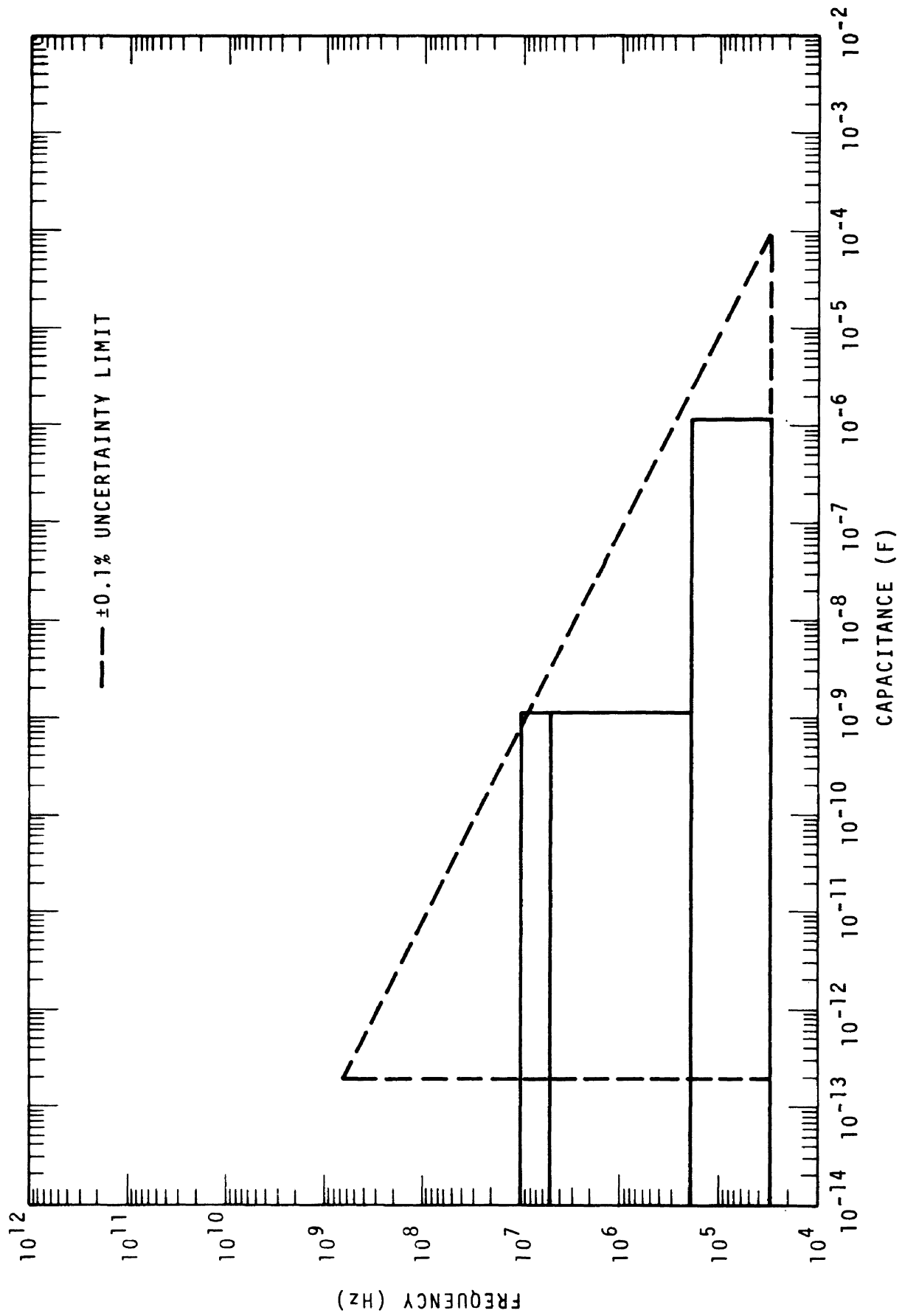
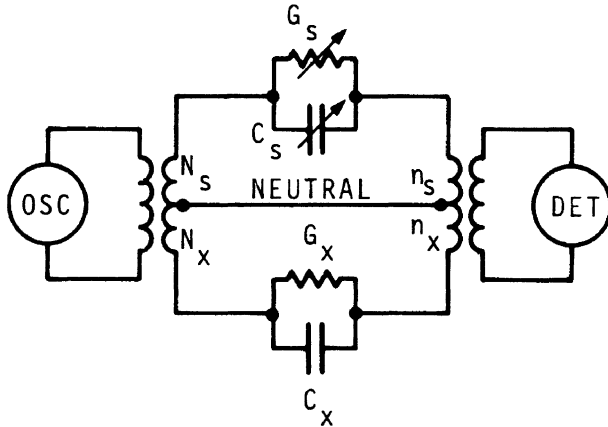

Figure 4-9. Admittance ratio bridge: Range of capacitance vs frequency.

d. Transformer Ratio Bridge

Categories Measured:  
A, B, C, D, E, F, G, H



BALANCE EQUATIONS:

$$G_x = \left( \frac{N_x}{N_s} \cdot \frac{n_x}{n_s} \right) G_s \quad (4-10)$$

$$C_x = \left( \frac{N_x}{N_s} \cdot \frac{n_x}{n_s} \right) C_s \quad (4-11)$$

Figure 4-10.

When used as an impedance bridge:

Range and uncertainty for resistance:

0.1 mΩ to 100 MΩ up to 10 MHz. Basic uncertainty ±1 to ±2 percent depending on frequency

Range and uncertainty for inductance:

Generally 10<sup>-11</sup> H to 10 H up to 10 MHz. Reduced ranges above 10 MHz. See chart. Basic uncertainty ±1 to ±2 percent depending on frequency

NOTE: On the accompanying resistance range charts no distinction is made between series or parallel resistance because they would be equal if the reactance or susceptance of the unknown being measured were equal to zero. These ranges require several instruments for coverage.

When used as an admittance bridge:

$10^{-8}$  S to  $10^4$  S up to 10 MHz decreasing to  $10^{-8}$  S to  $10^{-1}$  S above 10 MHz. Basic uncertainty  $\pm 1$  to  $\pm 2$  percent depending on frequency.

Range and uncertainty for capacitance:

Generally  $10^{-13}$  F to  $10^{-5}$  F up to 10 MHz. Reduced ranges above 10 MHz. See chart. Basic uncertainty  $\pm 1$  to  $\pm 2$  percent depending on frequency.

Comments:

This is a very versatile bridge circuit which offers some unique features including a wider measurement range than the conventional Wheatstone type circuits. The transformer ratio-arm bridge, capable of either two-terminal, three-terminal or balanced measurements, is less difficult to calibrate. The effects of internal residual impedances are easier to eliminate than in product-arm bridges so that internal shielding requirements present less of a problem.

Primary and secondary transformer turns-ratios in both the input and detector locations may be tapped to provide the effect of a variable internal standard. This eliminates the need for adjustable resistors and capacitors although they may be added for higher resolution. Principal error sources are the ratio transformers and degradation of ratio accuracies at high frequencies. The amount of degradation is highly dependent upon the design and construction of the transformers.

Additional measurement applications include "in situ" measurements, the measurement of transistor parameters, and the transfer impedances of two-port devices.

Several domestic versions of this bridge are available for lower frequency use, say up to 1 MHz, but higher frequency versions are not currently available except from foreign manufacturers. This bridge principle is the one most frequently used in automated measurements. Automated versions operate at specific fixed frequencies utilizing electronic switching, logic circuits, and digital readout or binary coded decimal (BCD) equipment. Go-no-go circuits are used to indicate whether or not an unknown falls above, below or within certain preset limits. Self-balancing admittance bridges also use this circuit.

A sophisticated version of this bridge with a unity transformer ratio has been built in the Soviet Union for measuring dielectric constant and loss tangent of solid dielectric materials up to 300 MHz. They have also used ratio transformers in bridge circuits for measuring permeability and its temperature coefficient, plus losses and various other characteristics of ferrites. [34]

In use the bridge is typical of manual impedance bridges in that the measurement process requires a few minutes to complete. Measurement time is somewhat shorter than with most null type bridges because a zero or initial balance is not required unless the bridge is being used as a comparator where the difference between two components is being determined. Calculations required are usually minimal.

Some of these instruments include an internal source and detector, especially those which operate at specific fixed frequencies; however most of the rf versions require an external source and detector.

Strengths:

- (1) Wide frequency range
- (2) Wide measurement range for resistance, inductance or capacitance

- (3) Relatively easy to calibrate
- (4) May be automated
- (5) Can measure grounded, balanced or unbalanced impedances or make in situ measurements
- (6) Commercially available

Weaknesses or Limitations:

- (1) Requires skilled operator
- (2) Slow

References pertaining to Transformer Ratio Bridge: [2,5,27,30,31,32,33,34,35]

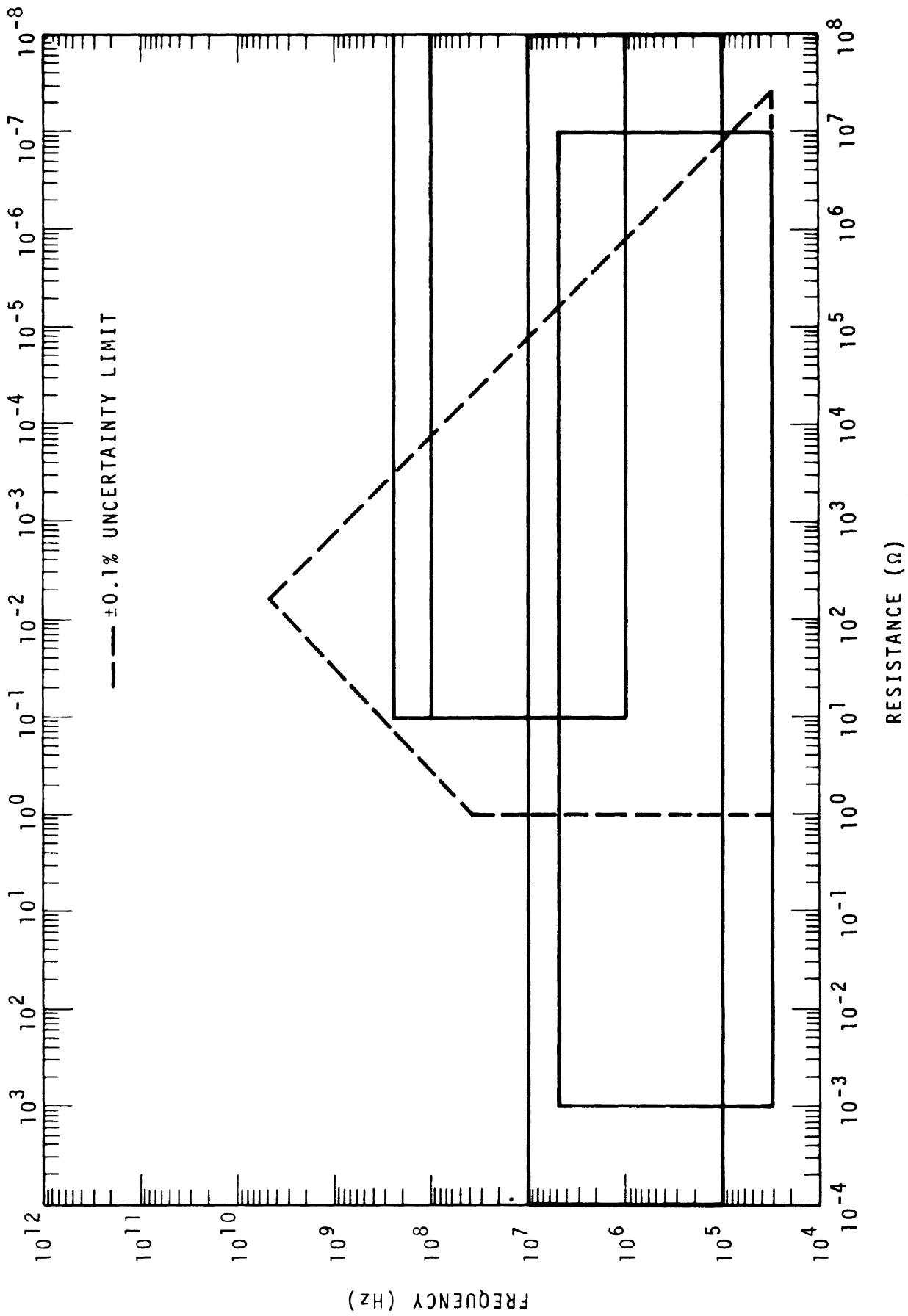

Figure 4-11. Transformer ratio bridge: Range of resistance vs frequency.



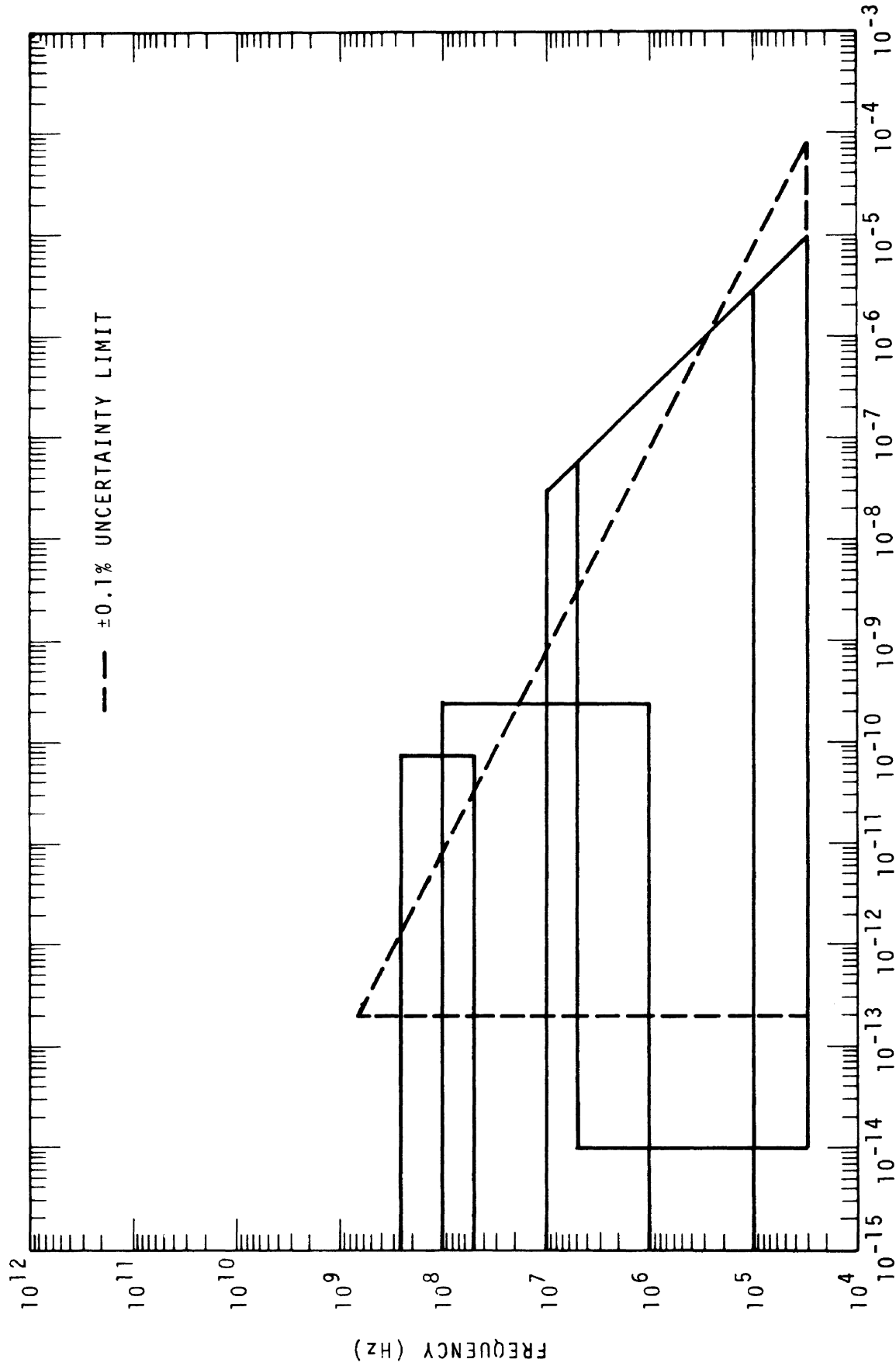
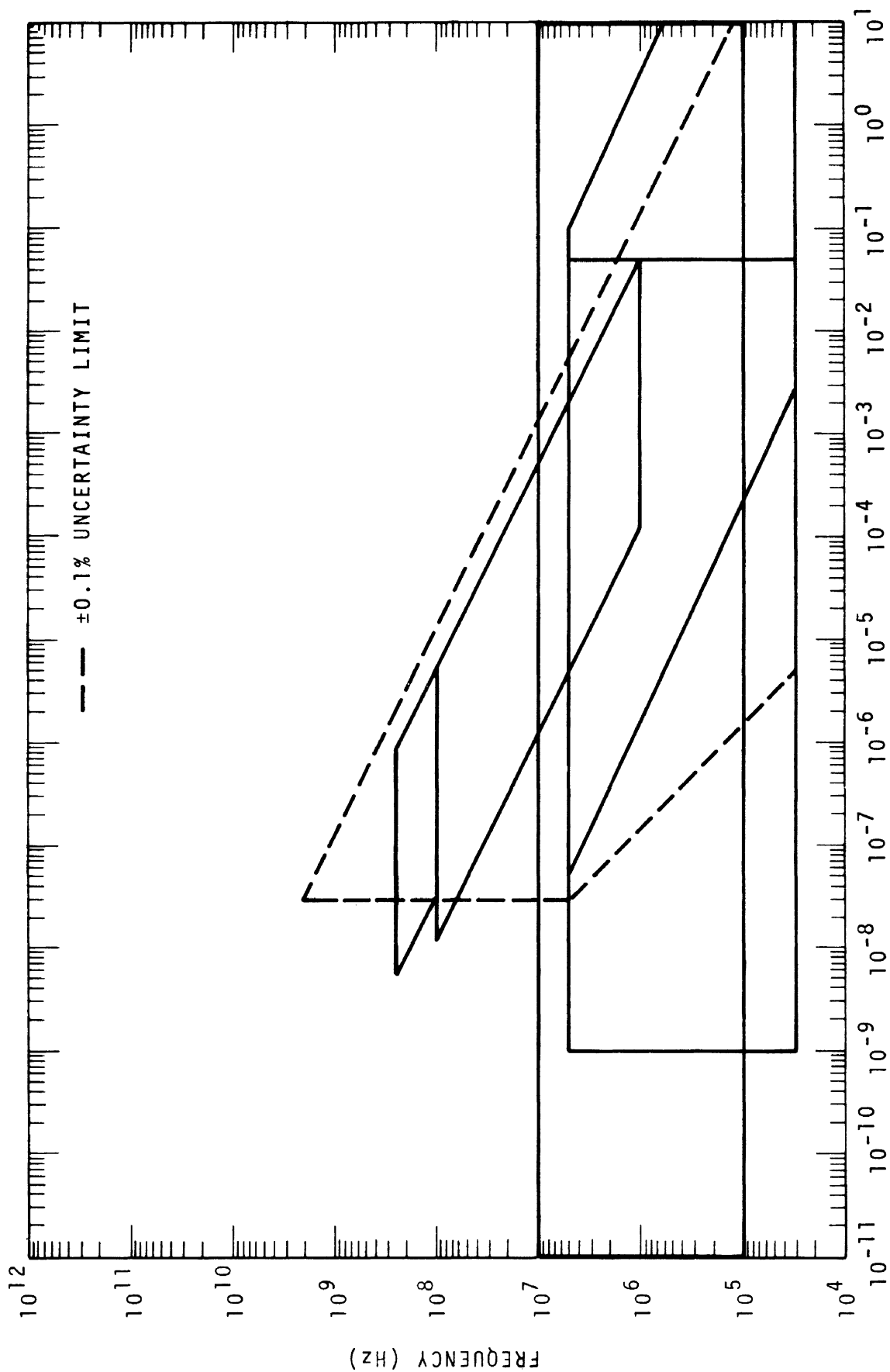
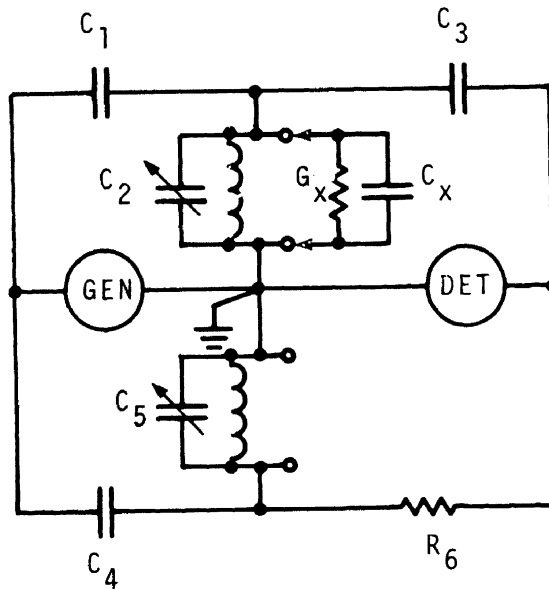

Figure 4-12. Transformer ratio bridge: Range of capacitance vs frequency.



INDUCTANCE (H) PLUS OR MINUS  
 Figure 4-13. Transformer ratio bridge: Range of inductance vs frequency.



BALANCE EQUATIONS:

$$G_x = \omega^2 \left( R_6 \frac{C_1 C_3}{C_4} \right) \Delta C_5 \quad (4-12)$$

$$C_x = \Delta C_2 \quad (4-13)$$

Figure 4-14.

Range and uncertainty for resistance:

1 k $\Omega$  to 50 M $\Omega$  at 30 kHz decreasing to 5 $\Omega$  to 300k $\Omega$  at 5 MHz. A high frequency version measured from 20  $\Omega$  to 300k $\Omega$  at 5 MHz decreasing to 20 $\Omega$  to 6k $\Omega$  at 300 MHz. Uncertainty  $\pm 0.1$  to  $\pm 0.2$  percent.

Range and uncertainty for capacitance:

0.1 to 5000 pF at 30 kHz decreasing to 0.1 to 50 pF at 300 MHz. Uncertainty  $\pm 0.1$  to  $\pm 0.2$  percent.

#### Range and uncertainty for inductance:

Inductance range is from 5 mH and up at 30 kHz and widens to 0.2  $\mu$ H and up at 5 MHz. For a higher frequency version the range is from 20  $\mu$ H and up at 5 MHz, with the lower limit decreasing to 50 nH at 300 MHz. Uncertainty  $\pm 0.1$  to  $\pm 0.2$  percent.

#### Comments:

The twin-T bridge is basically an admittance bridge and initial balance is made with respect to an open-circuit. It appears to have found its place in the standards laboratory in the role of performing measurements of high accuracy as opposed to being used as a field instrument or a general purpose tool for impedance measurement. There are a number of good reasons for this which are due to the characteristics of the bridge. Most notable is the fact that the bridge balance is frequency sensitive in that the factor,  $\omega^2$ , appears in the balance equations. This requires that the generator be highly stable and accurate in frequency to avoid error and virtually precludes the use of easily portable oscillators. Other features of the bridge include some unique advantages which make it very desirable for standards work. Generator, detector, unknown and standards share a common ground in the bridge circuit which makes for ease of shielding and helps in the elimination of error-causing ground loops. This bridge is used at high frequency for measuring resistance (or conductance) directly in terms of a capacitance change. Capacitance and inductance are also measured directly in terms of a capacitance change. This is the most accurate method for determining Q because at a particular frequency, Q is given as simply the ratio of two capacitance increments. The principle disadvantages of the bridge are that it is not simple to use, measurements are somewhat tedious and an experienced operator is mandatory.

No domestic version of the twin-T bridge is currently being manufactured and the one foreign version, though excellent, is expensive.

Strengths:

- (1) Versatile - Wide frequency range and wide impedance range for conductance, capacitance and inductance
- (2) Excellent accuracy capabilities
- (3) Utilizes variable capacitors as standards for both real and imaginary components
- (4) Can measure conductance directly in terms of a capacitance increment
- (5) Most accurate method for measuring Q

Weaknesses or limitations:

- (1) Requires highly skilled operator
- (2) Commercial procurement difficult
- (3) Expensive
- (4) Slow
- (5) Cannot measure small resistances

References pertaining to the Twin-T Bridge: [5,36,37,38,39,40]

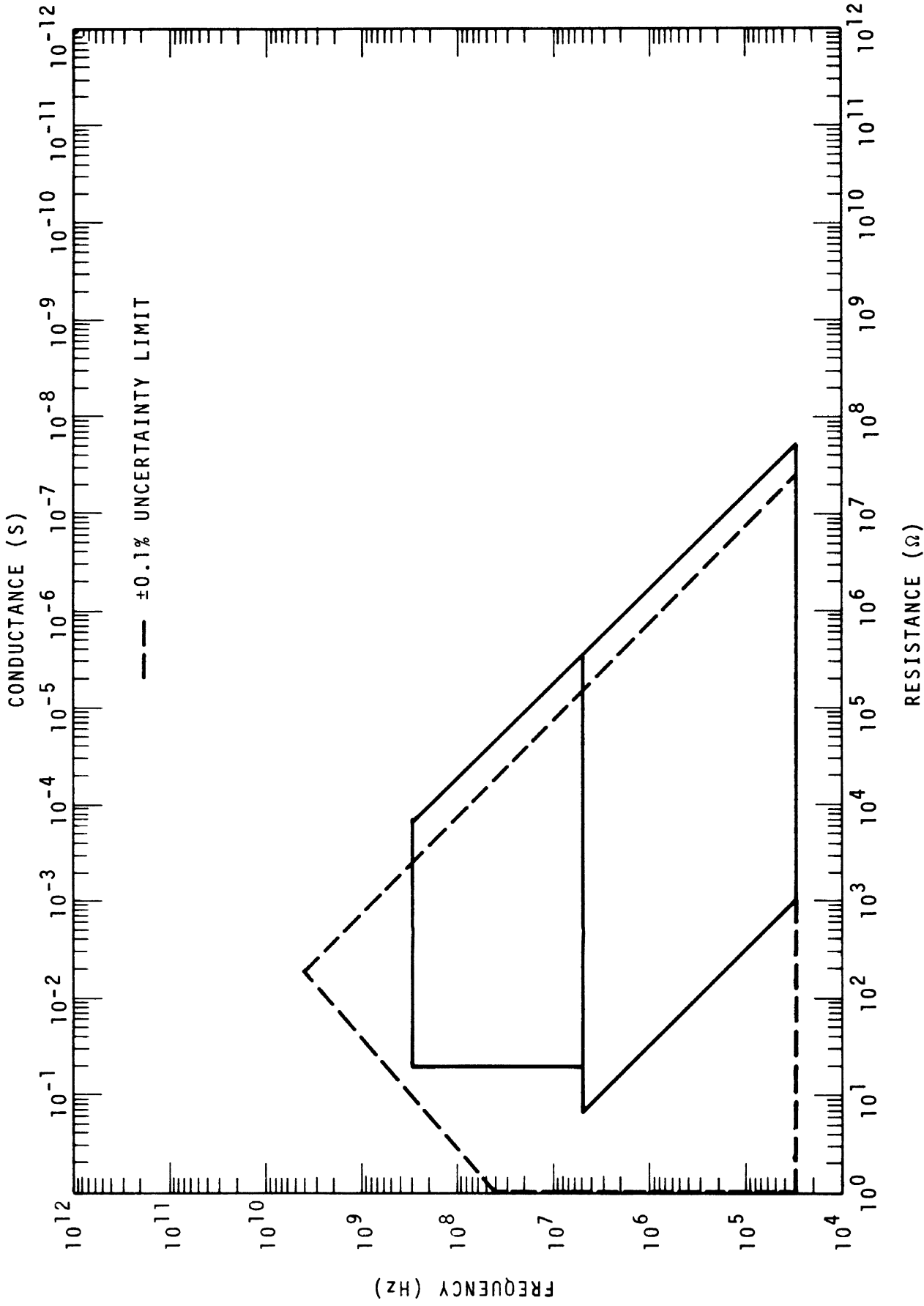

Figure 4-15. Twin-T Bridge: Range of resistance vs frequency.

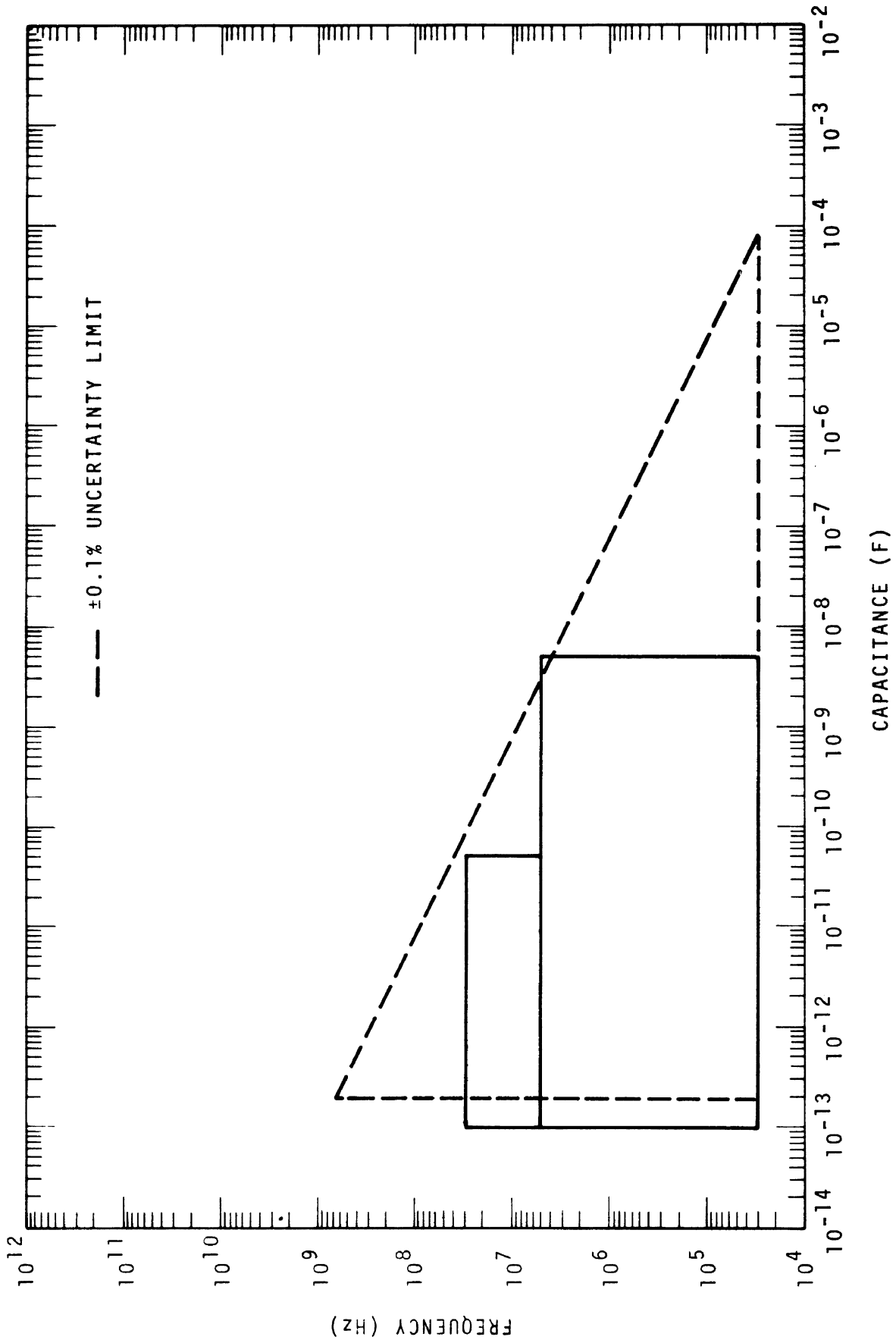

Figure 4-16. Twin-T Bridge: Range of capacitance vs frequency.

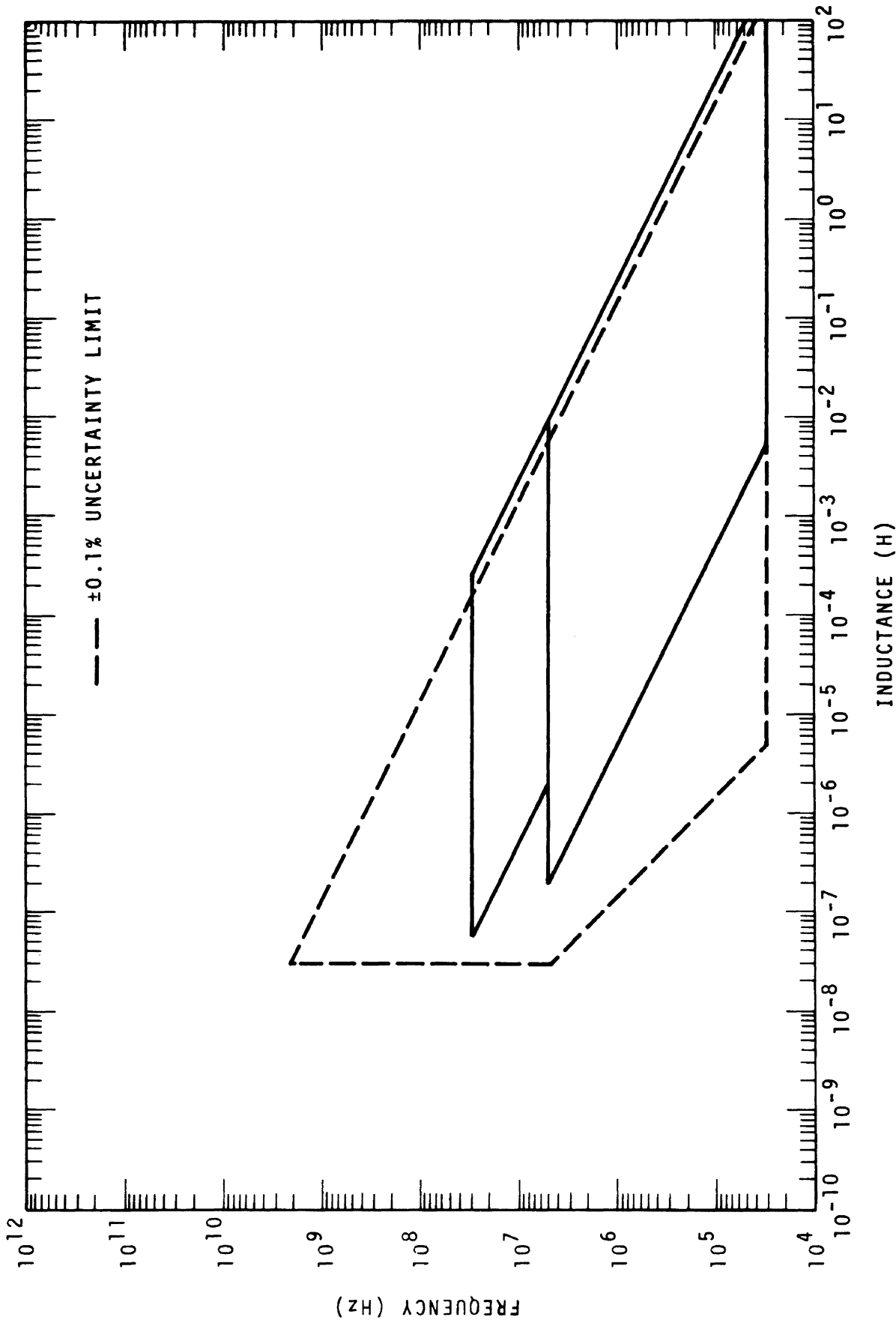

Figure 4-17. Twin-T Bridge: Range of inductance vs frequency.



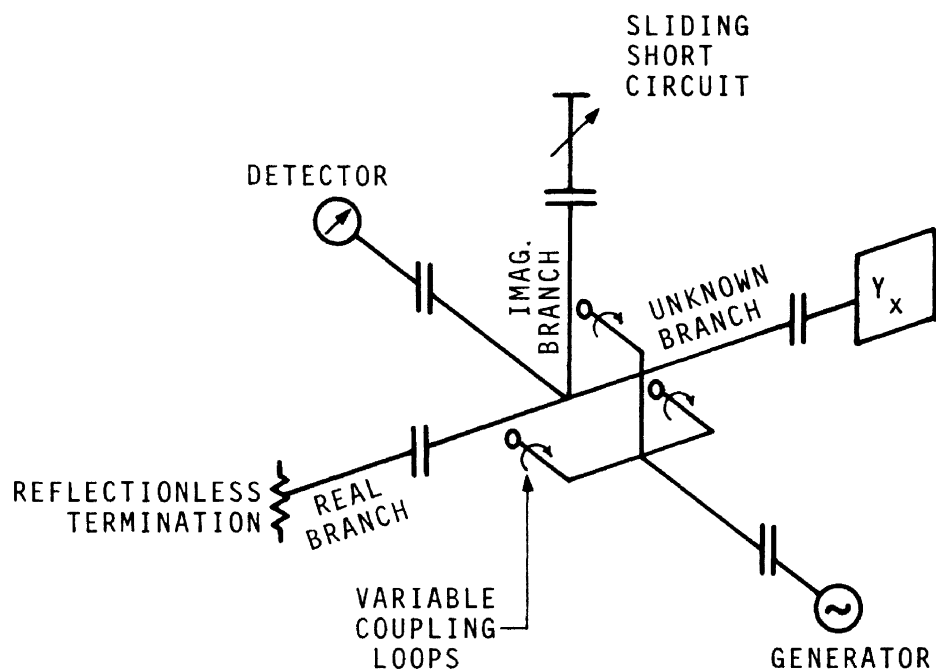

Figure 4-18.

Range and uncertainty for conductance:

10  $\mu\text{S}$  to 4000 mS from 40 to 1500 MHz. Basic uncertainty  $\pm 3\%$  to 1000 MHz increasing to  $\pm 5\%$  at 1500 MHz.

Range and uncertainty for susceptance:

$\pm (10 \mu\text{S} \text{ to } 4000 \text{ mS})$  from 40 to 1500 MHz. Basic uncertainty  $\pm 3\%$  to 1000 MHz increasing to  $\pm 5\%$  at 1500 MHz.

Comments :

Although the Thurston bridge is classified as a microwave bridge, its capabilities extend down into the frequency range covered by this metrology guide so that its inclusion here is appropriate even though it is not a lumped parameter device. The voltages are induced into the junction of the bridge branches by means of the inductive coupling loops and are proportional in magnitude to the angle of orientation of the plane of the loops with the center conductors of the respective branches of the bridge. The bridge is balanced when the detector voltage is at zero or null. This occurs when the current in the unknown branch, the real branch and the imaginary branch sum to zero.

$$I_x + I_r + I_i = 0 \quad (4-16)$$

Each induced current in each loop is:

$$I = kVY \quad (4-17)$$

where  $V$  is the generator voltage which is common to all three loops,  $Y$  is the branch admittance and  $k$  is the coupling coefficient which is proportional to the angle of orientation of the loop. If the real branch is terminated in a reflectionless admittance and the imaginary branch adjusted to an electrical distance of 45 degrees at the generator frequency, then the transformed admittance,  $Y'_x$ , of the unknown seen at the junction is given by

$$Y'_x = \frac{1}{k_x} (-k_r + jk_i) \quad (4-18)$$

Thus the normalized admittance,  $Y_x$ , can be deduced by transforming  $Y_x'$  through the length of line separating the unknown from the junction, or it may be read directly by using a lossless half wavelength line section between the unknown and the junction. Calibrated scales which read out directly in conductance, susceptance and multiplying factor are provided for the real, imaginary and unknown branches respectively.

In addition to limited resolution, the most significant errors arise from the fact that the loops are physically located a slight distance from the junction point. [46]

The bridge finds application in coaxial systems for impedance matching and adjustment, antenna measurements and as a comparator. Through its use, voltage standing ratios or reflection coefficients may be obtained.

Work has been done which in theory extends the range of the Thurston bridge to  $1/400 Z_0$  to  $400 Z_0$ ,  $Z_0$  being the characteristic impedance about which the bridge standards and readout is normalized. [47]

A modification of this instrument includes a built-in constant-impedance, adjustable-length lines in the form of a loop through the unknown and back to the junction permitting the measurement of transfer impedance and admittance on both active and passive four terminal networks.

#### Strengths:

- (1) Suitable only for measurements above 40 MHz
- (2) Versatile - can be used to measure transistor parameters and has a broad admittance range
- (3) Commercially available
- (4) Relatively inexpensive
- (5) Broad susceptance range including both positive and negative susceptance capability

**Weaknesses or Limitations:**

- (1) Relatively low accuracy and resolution
- (2) Not usable at lower frequencies
- (3) Requires experienced operator
- (4) Slow

**References pertaining to the Thurston Bridge: [42,43,44,45,46]**

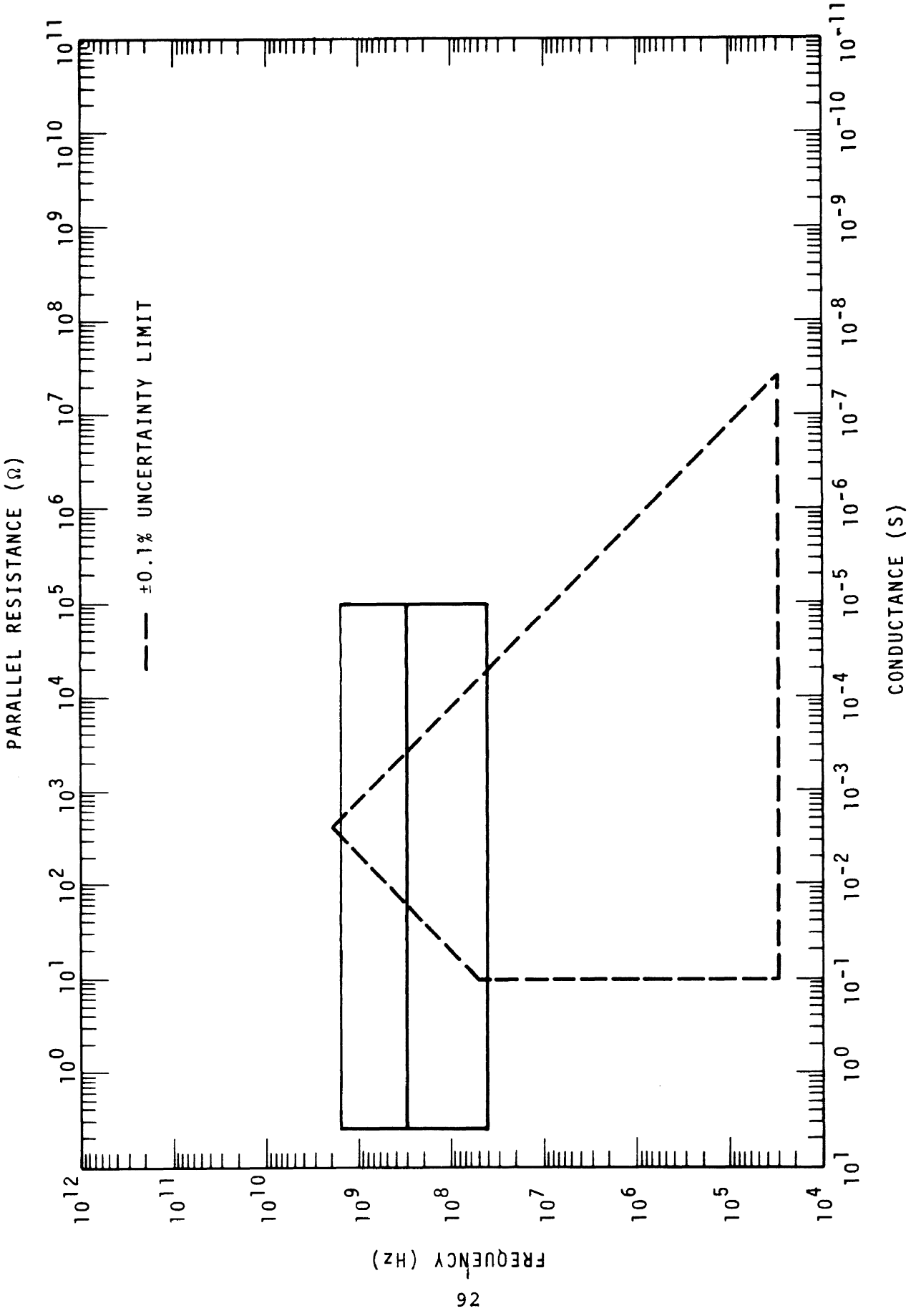

Figure 4-19. Thurston Bridge: Range of conductance vs frequency.

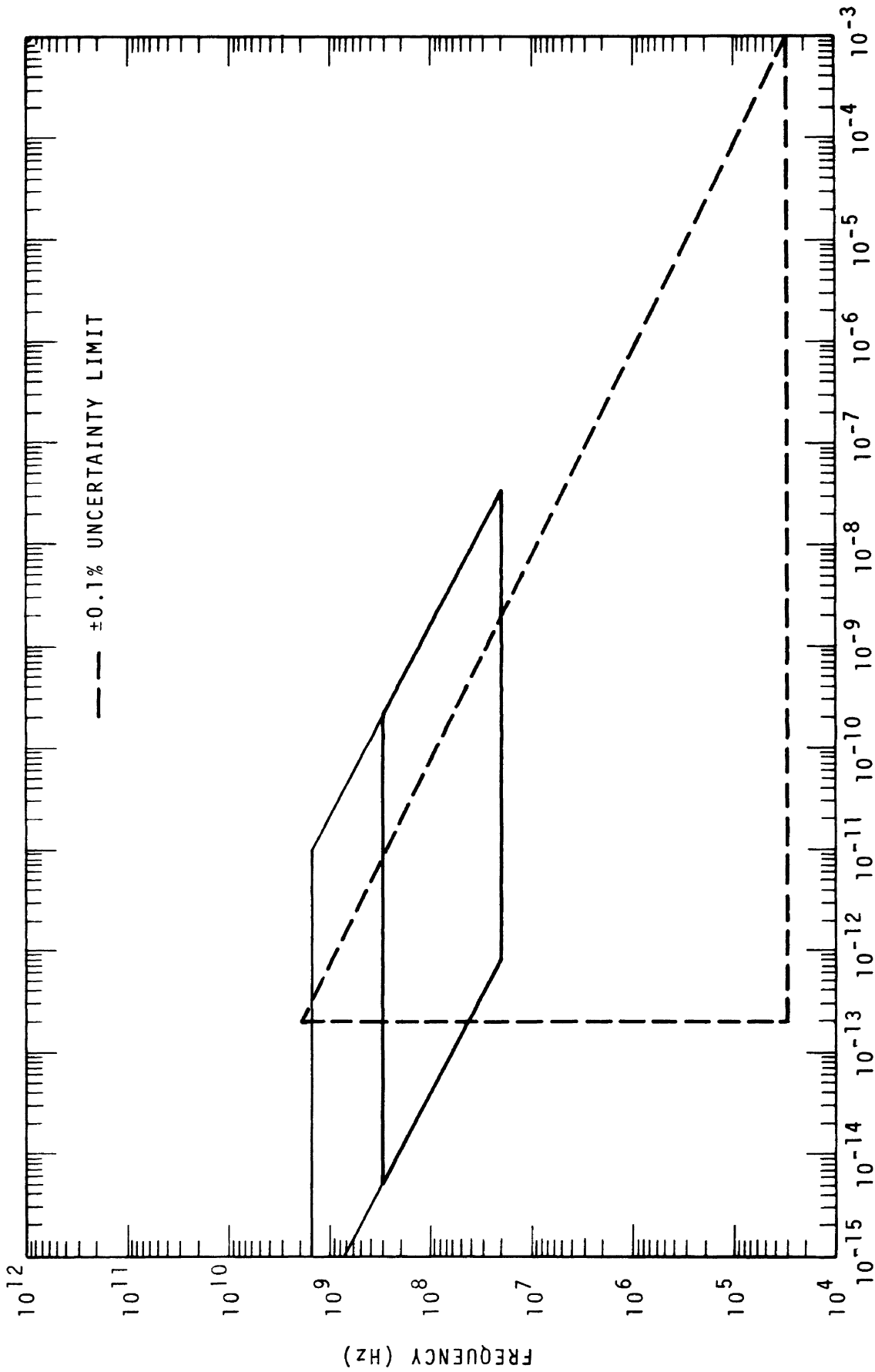
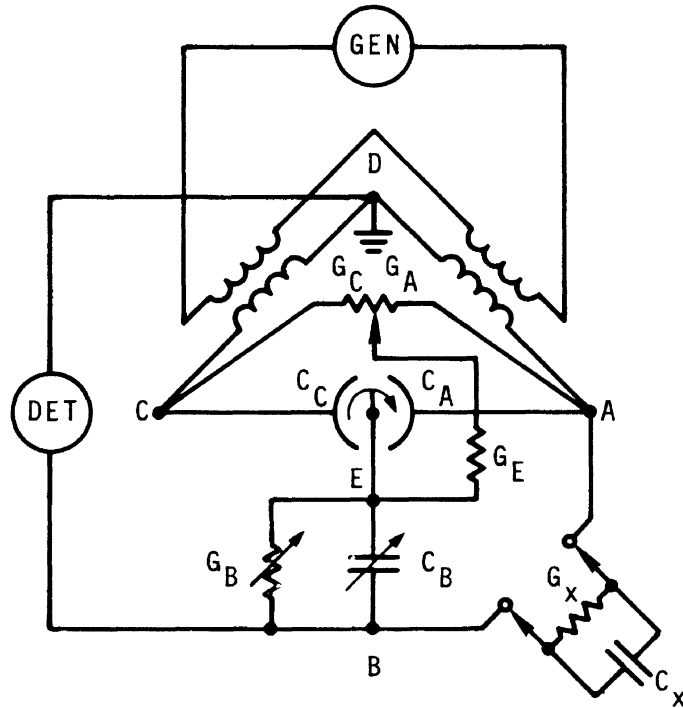

Figure 4-20. Thurston bridge: Range of positive or negative capacitance vs frequency.



BALANCE EQUATIONS:

$$G_X = k(G_A - G_C) \quad (4-19)$$

$$C_X = k(C_A - C_C) \quad (4-20)$$

Figure 4-21.

Range and uncertainty for conductance:

0.01  $\mu\text{S}$  to 1000  $\mu\text{S}$  at fixed frequencies of 100 kHz, 465 kHz and 1 MHz. Basic uncertainty  $\pm 10\%$ .

Range and uncertainty for capacitance:

0.00002 to 1000 pF at fixed frequencies of 100 kHz, 465 kHz and 1 MHz. Basic uncertainty  $\pm 0.25\%$ .

Comments:

The Young bridge circuit was devised especially for measurement of extremely small values of capacitance. The operating principle is based on the conversion of the wye configuration of admittances between bridge corners A,B and C to the equivalent delta and the use of differential capacitance and conductance standards to maintain constant and equal admittances in arms AB and BC. Bridge multipliers from 1 to  $10^{-4}$  are obtained by switching various admittance combinations between points E and B. The unknown is inserted across AB after an initial balance has been established. The bridge is then rebalanced and is direct reading in conductance and capacitance. Because of the wye to delta conversions, the circuit is restricted to operation only at fixed design frequencies. Domestic versions of the modified Young bridge are commercially available and contain built-in oscillator and detector. Provisions are available for measurement of unknowns with external bias applied. The bridge may be used for either three-terminal (direct) or grounded admittance measurements. Operation is relatively simple; although the original Young bridge was restricted to measurements only at fixed frequencies, modifications have been incorporated in modern commercial versions which permit its use over a range of frequencies extending as high as 1 MHz.

References pertaining to the Young Bridge: [47]



**Strengths:**

- (1) Excellent for measuring very small admittances
- (2) Capable of in situ measurement or measurements of remotely located components
- (3) Good accuracy capabilities
- (4) Commercially available
- (5) Versatile - may be used for either two-terminal or three-terminal measurements

**Weaknesses or Limitations:**

- (1) Usable only at fixed frequencies
- (2) Upper frequency limit approximately 1 MHz
- (3) Cannot be used for small impedance measurement, i.e., resistance and inductance
- (4) Requires experienced operator
- (5) Slow

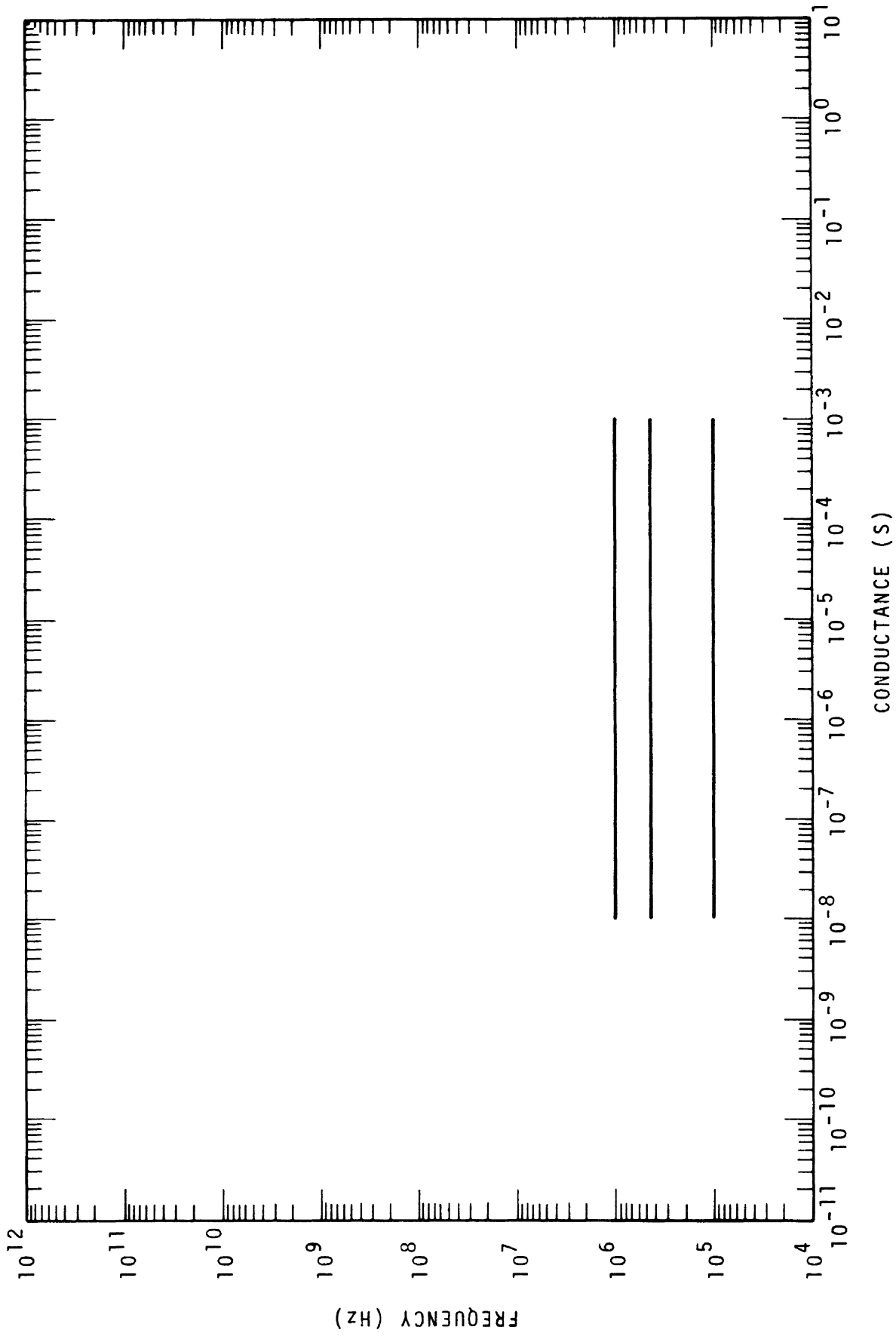

Figure 4-22. Young bridge: Range of conductance vs frequency.

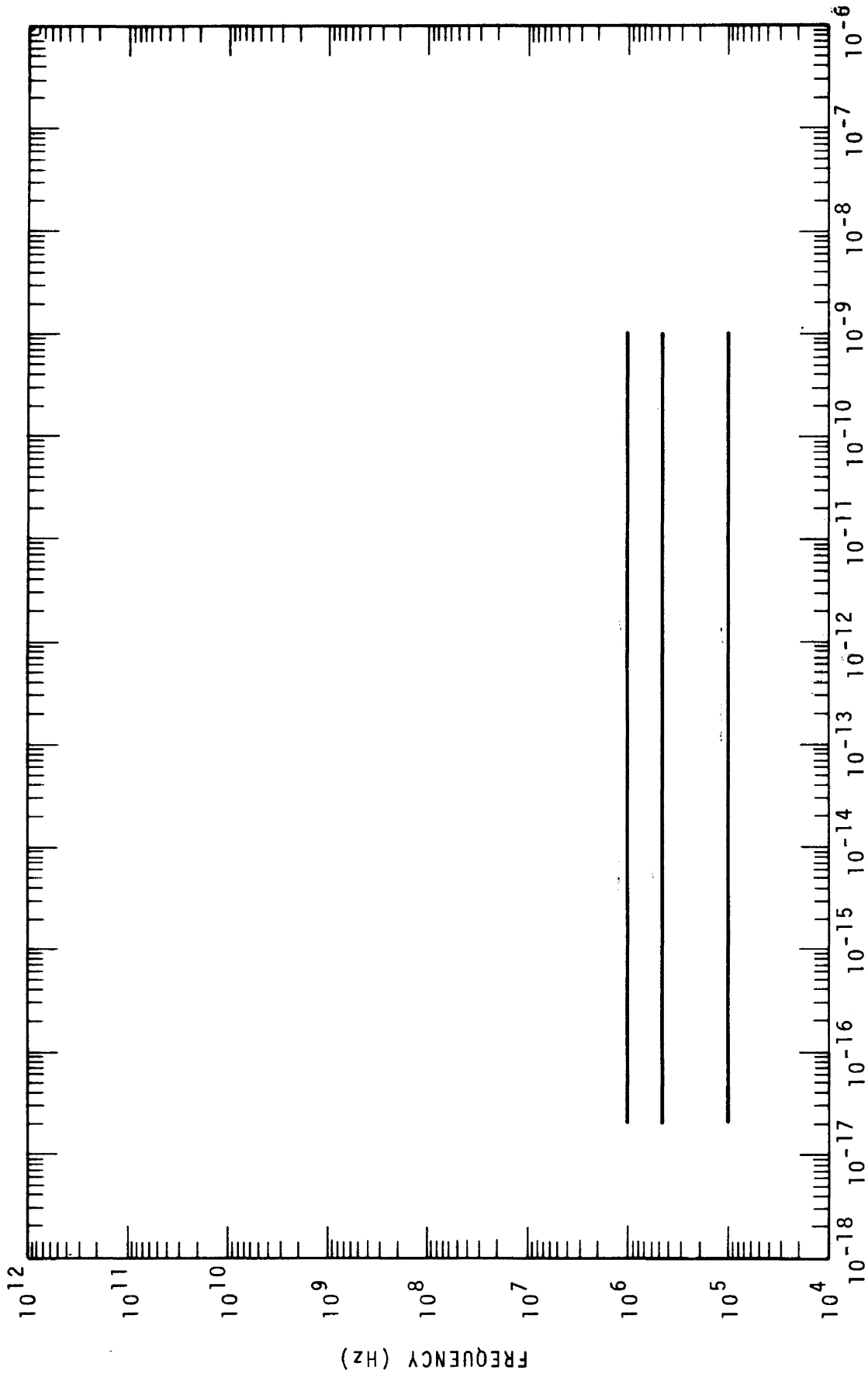

Figure 4-23. Young bridge: Range of capacitance vs frequency.

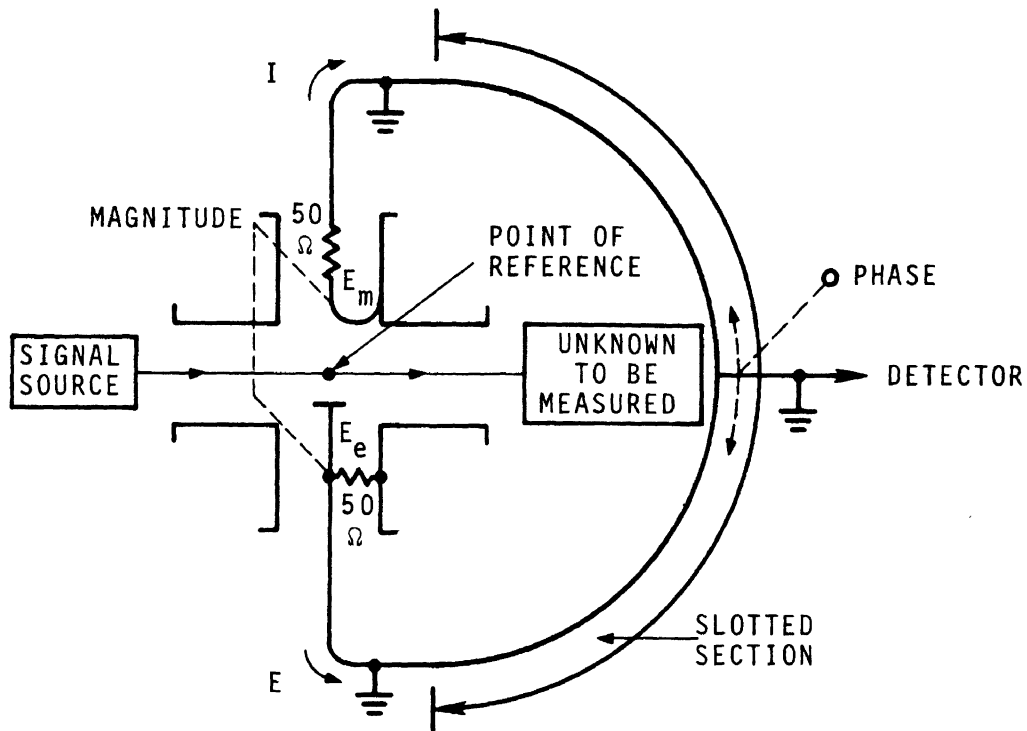

Figure 4-24.

Range and uncertainty of resistance or impedance magnitude measurement:

2 to 2000 Ω from 50 to 500 MHz. Basic uncertainty ±5%, useful over an extended range of from 5 to 700 MHz at higher uncertainties.

Range and uncertainty of phase angle measurement:

-90° to +90° from 50 to 500 MHz. Basic uncertainty  $\pm 3^\circ$ .  
Can be used from 5 to 700 MHz at reduced range and higher  
uncertainty. Phase angle range  $+9^\circ$  to  $-9^\circ$  at 5 MHz.

Range and uncertainty of inductance measurement:

From 7nH to 7 $\mu$ H at 5 MHz decreasing to 0.7nH to 0.7 $\mu$ H  
at 500 MHz. Accuracy limited mainly by the uncertainty  
in measuring magnitude of impedance which is a function  
of frequency.

Range and uncertainty of capacitance measurement:

From 1.5 pF to 1500 pF at 5 MHz decreasing to 0.15 pF at  
500 MHz. Accuracy limitation the same as for inductance.

Comments:

Although the Byrne bridge reads out in terms of impedance  
magnitude and phase angle, and thereby should not be classified  
as an instrument for lumped parameter measurement, it is included  
here because its operating frequency extends well down into what  
has been designated as the lumped parameter frequency range.  
Strictly speaking this instrument is not a bridge although it  
does rely upon a null principle. In practice the actual  
operation is exactly the same as a bridge with two adjustable  
controls and dials which are read directly.

In operation a square wave modulated sinusoidal signal of  
the desired measurement frequency is fed directly down a short  
section of coaxial line into the unknown to be measured.<sup>2</sup>

<sup>2</sup>Caution: In the usual arrangement of generator, bridge and  
detector, all of the generator power goes directly into the  
unknown. Care should be exercised to avoid damage to unknowns  
having low power capacity. It is also possible to reverse the  
generator and detector connections to avoid this problem, but  
such a manner of connection results in reduced sensitivity.

The impedance characteristics of the unknown are determined from the resulting standing wave pattern at a specific reference point in the line. This, of course, is no different from the way a slotted line operates. The differences arise in the means for obtaining the measurement information. In the Byrne bridge this is done directly and automatically so that time consuming calculations and tedious measurement procedures, characteristic of slotted line measurements, are avoided. Hence, operator skill is much less important. Ganged capacitive and inductive probes located at the point of reference are calibrated to read directly in impedance magnitude at all frequencies, and a detector probe in the slotted section provides a direct readout in phase angle at some fixed frequency, usually 100 MHz. At other frequencies the phase angle is obtained by multiplying the dial reading by the ratio of the measurement frequency to the fixed frequency at which the dial is calibrated.

Principal error sources are the uncertainty of the measurement reference point location, probe loading or coupling, mismatch of terminations, non-uniformity in the slotted section and stray pickup in the null detector. Stray pickup in the null detector is easily detectable by the fact that leads become "hot." The remedy for the problem is more elaborate shielding. Ultimate measurement accuracy is poorer than that obtainable by slotted lines when used at the same frequency. Voltage level stability is not as important for the Byrne bridge as it is with slotted lines because of the different approach to the measurement of impedance magnitude.

Although neither foreign nor domestic models are now available, a domestic version was manufactured, and no doubt many are still in use. This instrument has probably been superseded by automated vector impedance meters.

Calibration of this instrument is quite simple compared to most null type instruments and is carried out by measuring

a 50 ohm load, an open-circuit, and a short-circuit at as many frequencies as desired in the range of operation. This provides only a partial calibration however, and more elaborate procedures must be followed for further error reduction.

Strengths:

- (1) Wide range of capabilities for impedance magnitude and phase angle
- (2) Operation and data interpretation simple compared to slotted line
- (3) Few calculations required

Weaknesses or Limitations

- (1) Reduced measurement capabilities below 50 MHz
- (2) Relatively low accuracy
- (3) Slow
- (4) No longer commercially available
- (5) Recommended only for measurement of devices with coaxial connectors

References pertaining to Byrne Bridge: [48,49]

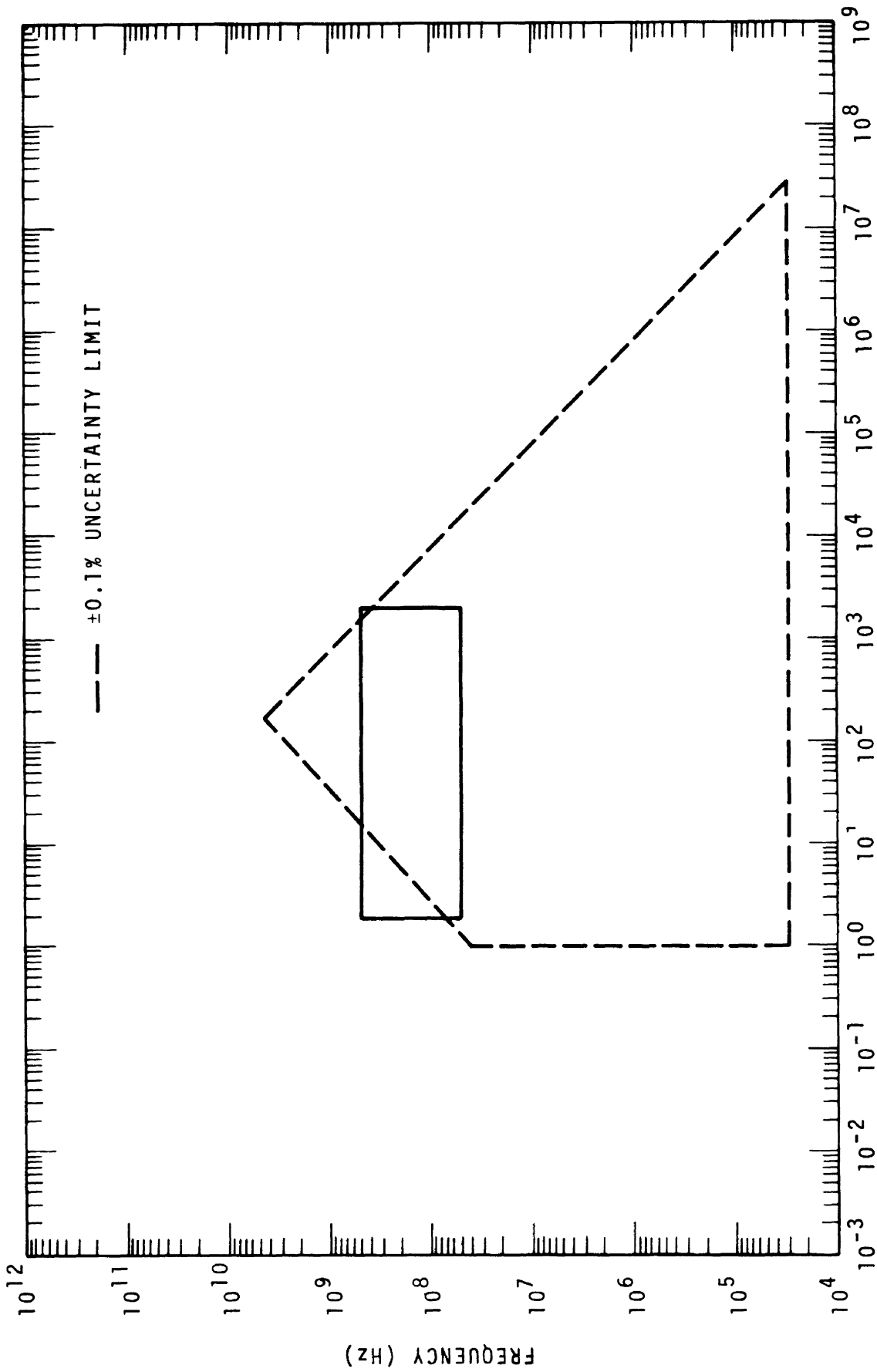

Figure 4-25. Byrnes bridge: Range of resistance or impedance magnitude vs frequency.



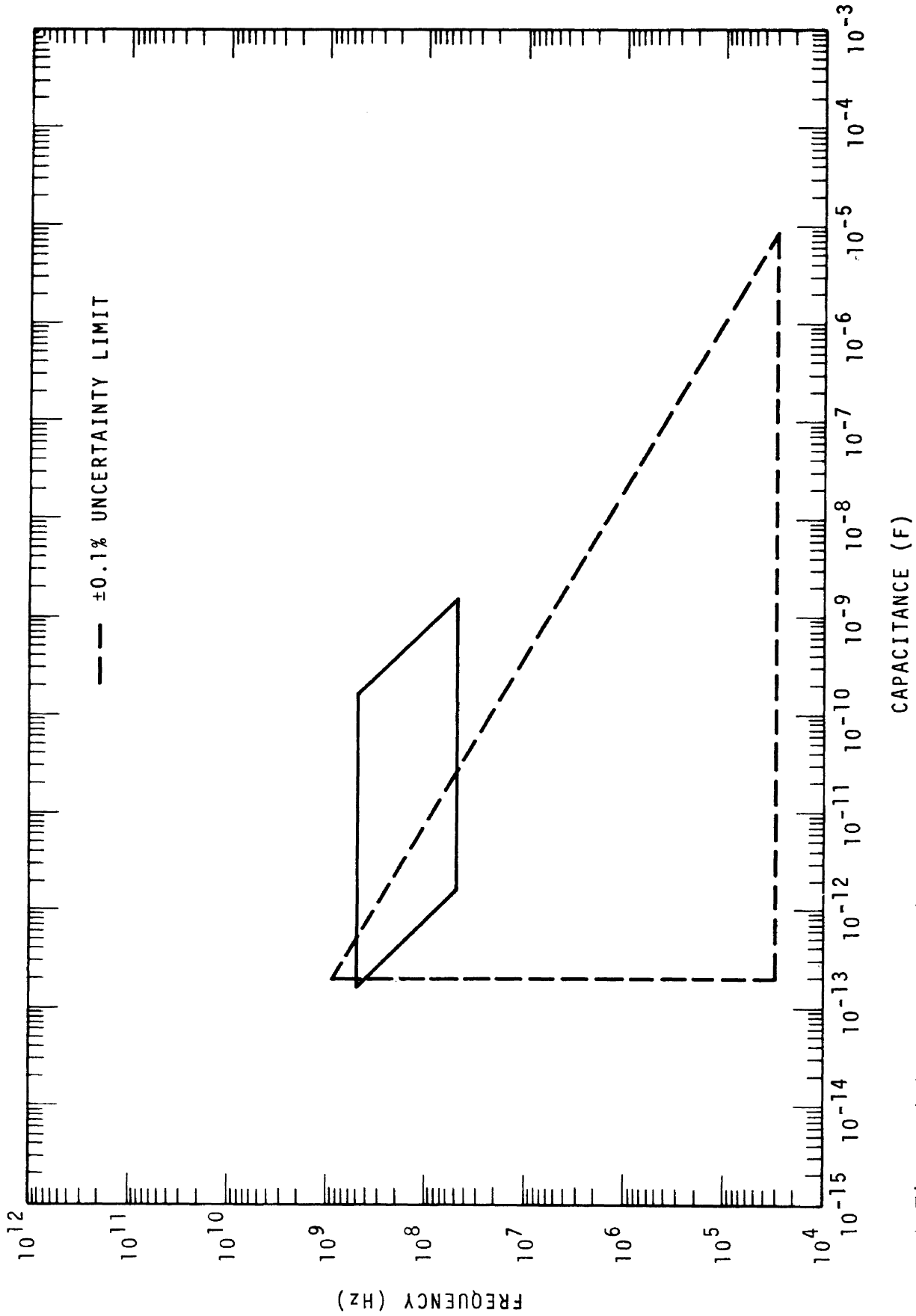

Figure 4-26. Byrnes bridge: Range of capacitance vs frequency.

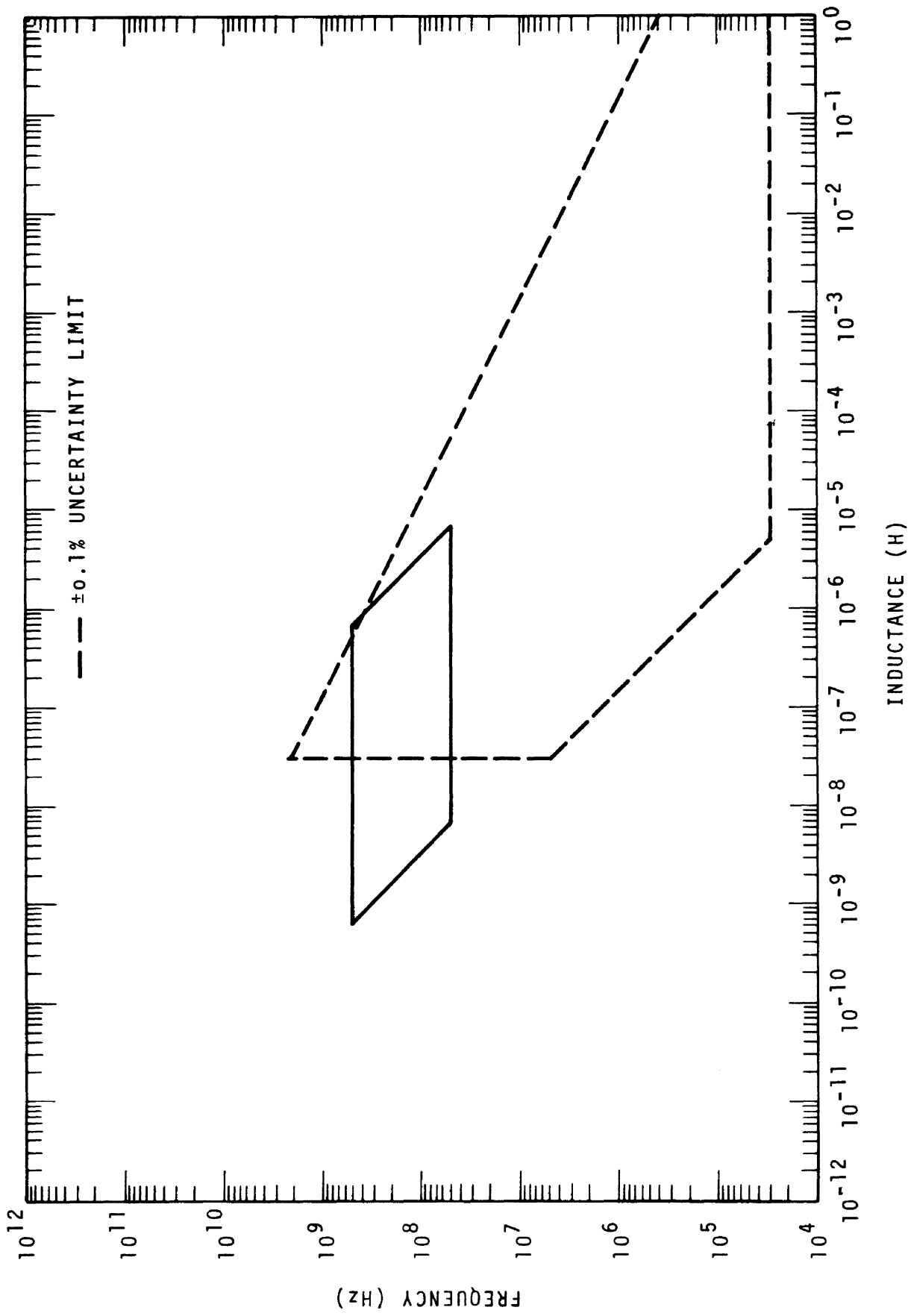
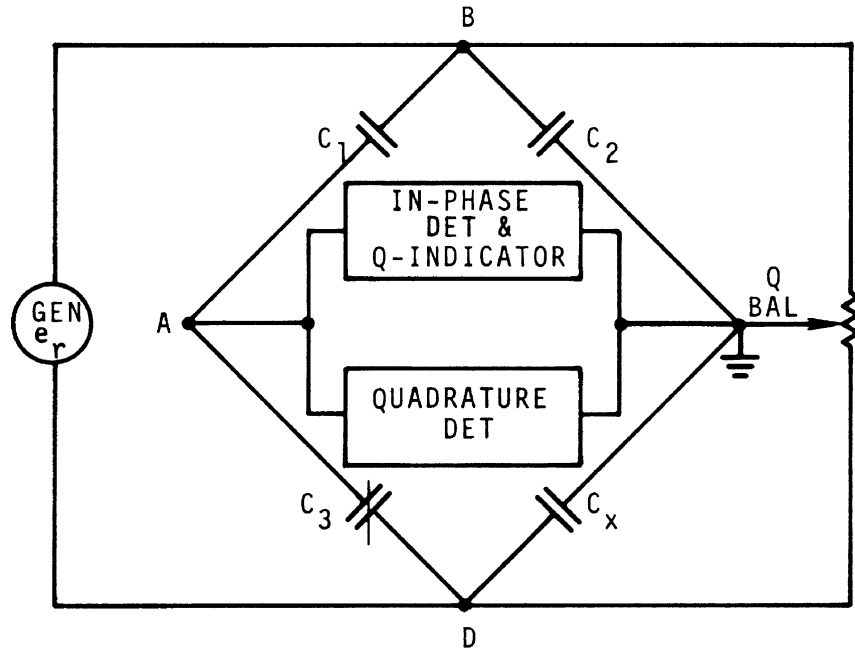

Figure 4-27. Byrne bridge: Range of inductance vs frequency.



BRIDGE EQUATIONS:

$$C_x = \frac{C_2}{C_1} \Delta C_3 \quad (4-14)$$

$$Q = \frac{e_o}{e_r} \quad (4-15)$$

Figure 4-28.

Range and uncertainty for Q:

5 to 10,000 from 100 kHz to 50 MHz. Basic uncertainty  $\pm 10\%$  increasing with frequency and value of Q being measured

Range and uncertainty for capacitance:

20 pF to 1000 pF from 100 kHz to 50 MHz. Basic uncertainty  $\pm 0.5\%$ , increasing with frequency.

Comments:

The Q-bridge actually embodies two measurement principles; a situation made possible through the use of a phase sensitive detector. The bridge elements and the unknown are arranged in the traditional Wheatstone configuration, and the detector separates the unbalance voltage between points A and C into its in-phase and quadrature components, the in-phase component being due to reactance unbalance. The reactance balance is made by adjusting the in-phase voltage to a maximum, using the Q balance control, the Q of the unknown is read directly as the ratio of the in-phase unbalance voltage  $e_o$  to the generator reference voltage,  $e_i$ . Measurement accuracy is apparently somewhat lower than a Q-meter but there are other advantages, especially in the versatility of the instrument for measuring capacitance beyond its direct reading range. With all four bridge corners brought out to accessible terminals either capacitance or inductance may be measured through the use of ratio arm, product arm or substitution methods. The range for Q measurement also goes beyond the Q-meter although the uncertainty increases to the order of  $\pm 20\%$  at 1 MHz for Q of 10,000. Through the connection of external capacitors, the capacitance measuring capability may be extended to cover 0.002 pF to 0.25  $\mu$ F. External standards can also be used to provide inductance measuring capabilities as follows:

Range and uncertainty for Q:

5 to 500 from 100 kHz to 50 MHz. Basic uncertainty  $\pm 10\%$  increasing with frequency and measured value of Q.

Range and uncertainty for inductance:

0.1  $\mu\text{F}$  to 100 mH. Basic uncertainty  $\pm 5\%$ .

Strengths:

- (1) Has high Q-measuring range
- (2) Versatile - can be used to measure a wide variety of impedances and admittances
- (3) Commercially available

Weaknesses or Limitations:

- (1) Relatively low accuracy for Q-measurement
- (2) Requires experienced operator
- (3) Slow
- (4) Measures only components with Q of 5 to 500

Reference pertaining to Q-Bridge. [41]

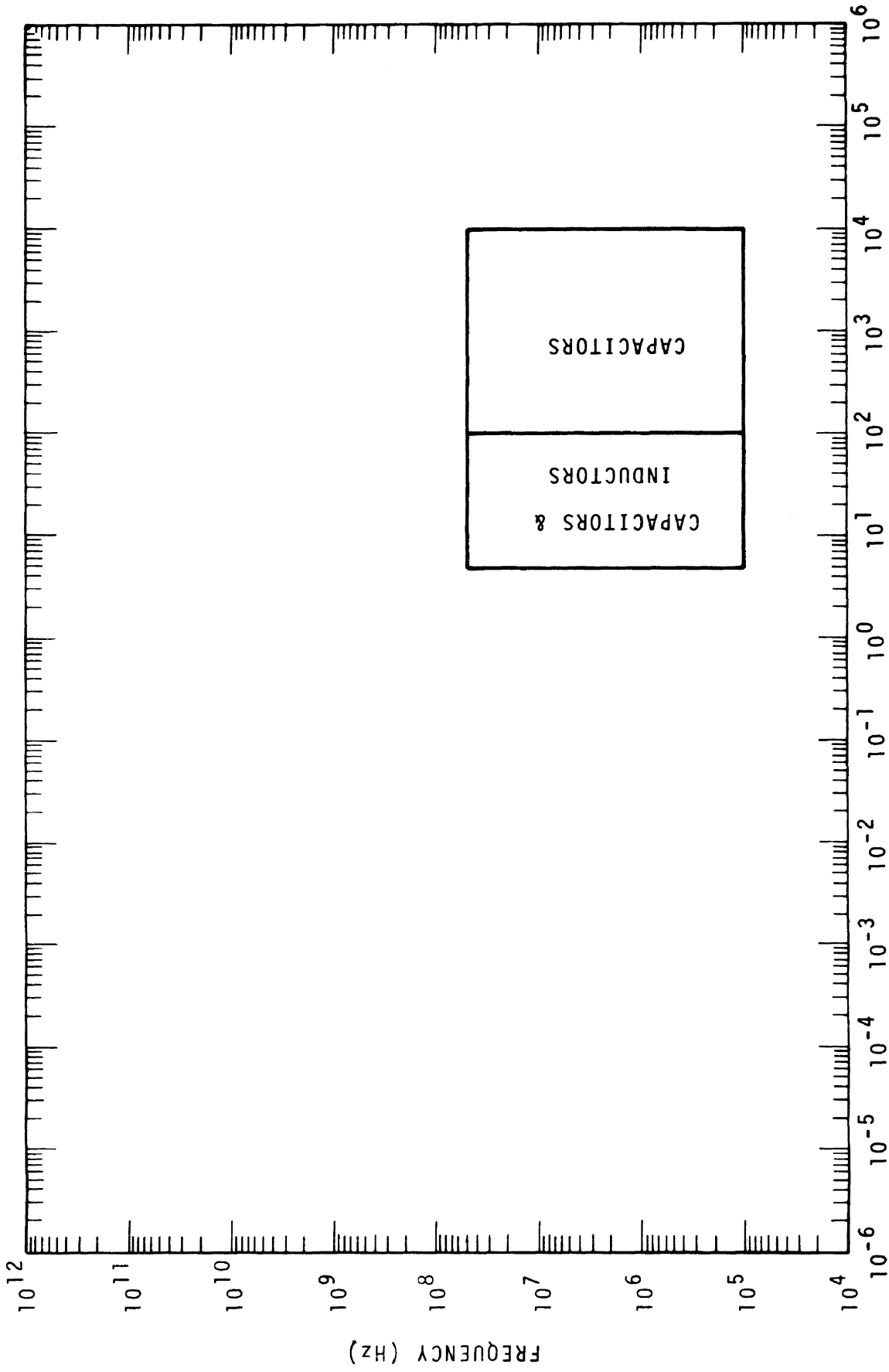

Figure 4-29. Q-bridge: Range of Q vs frequency.

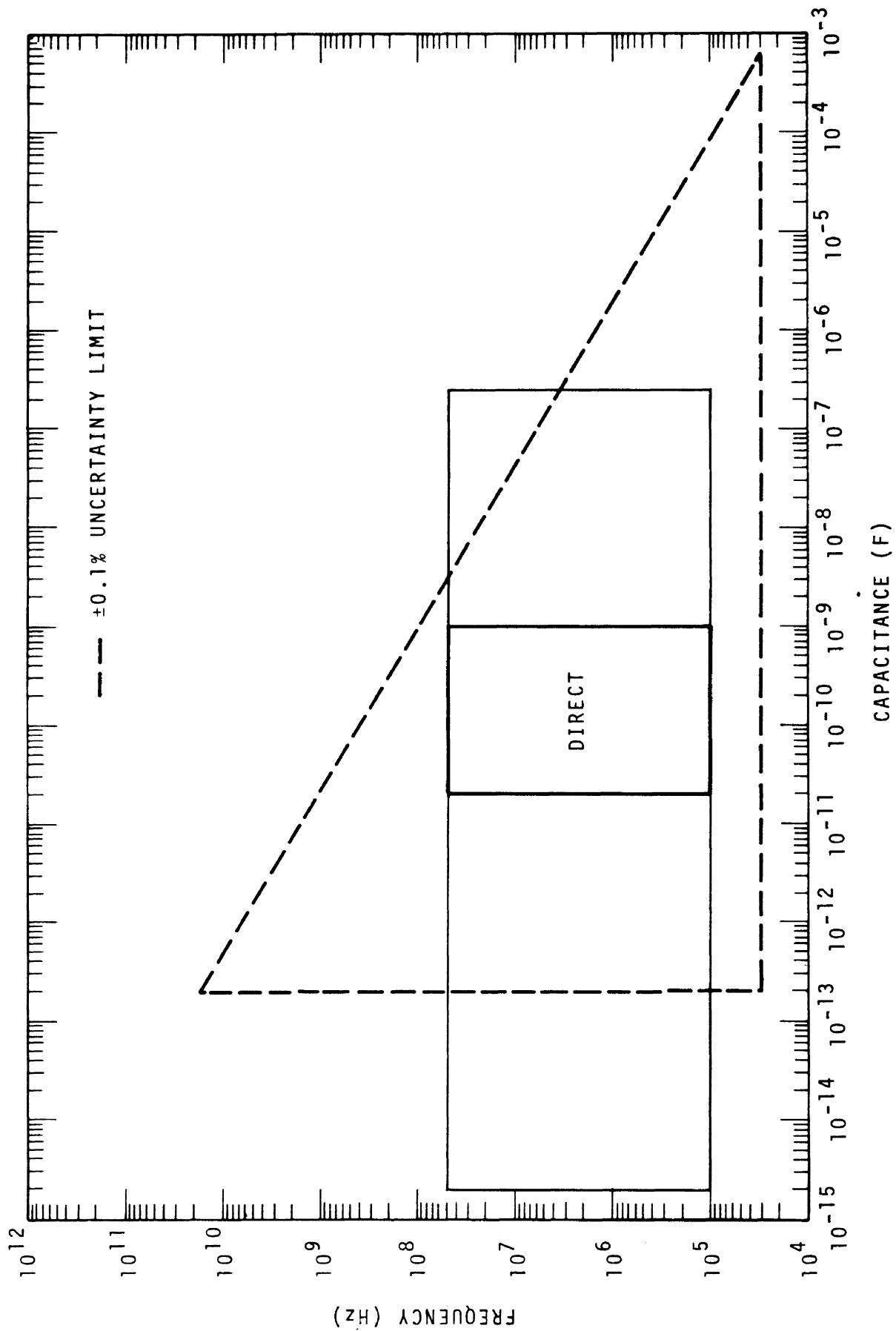
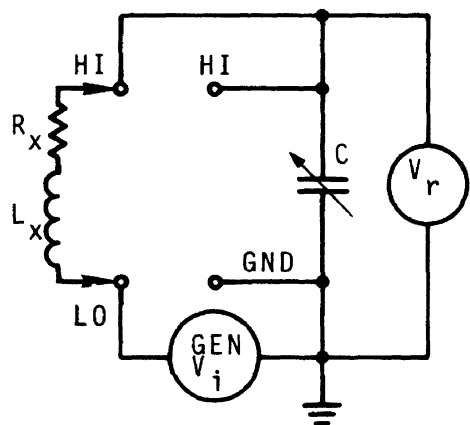

Figure 4-30. Q-bridge: Range of capacitance vs frequency.

## 4.2. Resonance Instruments

### a. Q-Meter

Categories Measured, E,F



MEASUREMENT EQUATIONS:

$$Q_x = \frac{\omega L_x}{R_x} = \frac{V_R}{V_i} \quad (4-21)$$

$$L_x = \frac{1}{\omega_r^2 C_r} \quad (4-22)$$

Figure 4-31.

Range and accuracy of Q measurements:

10 to 1000 from 30 kHz to 300 MHz. Uncertainty of Q depends upon measurement frequency and value of Q being measured but generally varies from  $\pm 5\%$  to  $\pm 15\%$  with Q-meters usually reading low.

Range and accuracy of capacitance measurement:

20 to 500 pF up to 50 MHz and 10 to 100 pF from 20 MHz up to 300 MHz. Uncertainty  $\pm 1\%$



Range and accuracy of inductance measurement:

50 mH to 1.4 H at 30 kHz decreasing to 20 nH to 0.6  $\mu$ H at 50 MHz for lower frequency versions. Higher frequency versions measure from 0.5  $\mu$ H to 9  $\mu$ H at 20 MHz decreasing to 2.5 nH to 40 nH at 300 MHz. Uncertainty basically  $\pm 1\%$ .

Comments:

The Q-meter has long been one of the most versatile and widely used instruments available for impedance measurement. It is used in many forms and is available from a number of sources both foreign and domestic. The most common version reads directly in Q and resonating capacitance, and at certain frequencies a direct reading inductance scale is provided. Measurements can usually be made quickly (more quickly than with a conventional, manually operated impedance bridge) because no initial balance is required. Because of the extra set of terminals in parallel with the internal Q-meter capacitor, it is very easy to achieve measurements of components whose values fall outside the direct reading range of the instrument. This, of course requires the use of external standards, and most manufacturers provide such standards together with ample instructions in these procedures as a part of the instruction manual for the Q-meter. It should be noted, however, that such procedures almost invariably bring new error sources into the picture which must be carefully evaluated and compensated for best results.

The fact that both capacitance and frequency may be varied easily by means of simple external controls greatly enhances the versatility of the Q-meter. This feature is not available in other instruments, and makes the Q-meter an especially useful tool for design or trouble shooting applications.

Q-meters which utilize a resistance in the circuit for the insertion of the test signal voltage should not be used for making measurements on components with external dc bias applied because of the risk of damage either to the insertion resistor, the associated thermocouple unit, or the fact that such a bias would seriously alter the calibration of the Q scale of the detecting voltmeter. The Q-meter is not suitable for "in situ" measurements.

Q-meters may be used directly or indirectly for the following: 1) Q of inductors and capacitors 2) Self-capacitance of inductors 3) Inductance 4) Capacitance 5) Power factor 6) Dielectric constant 7) Permeability 8) Low and high rf resistance and impedances.

A more recent version of the Q-meter has appeared where the measurement principle is based upon the logarithmic decrement of an oscillation in a parallel resonant circuit composed of the unknown inductor and a standard capacitor contained within the instrument. An initial square wave pulse is applied to the resonant circuit which may contain any preset capacitance between 50 pF and 0.01  $\mu$ F. The measuring circuitry displays the resonant frequency of the circuit and also displays the Q which is derived from a counter circuit in accordance with the time required for the signal to decay to  $e^{-\pi}$  of the original voltage amplitude. The frequency range of measurement is from 1 kHz to 12 MHz. The instrument provides a digital readout for Q and for the resonant frequency which results for the various capacitance values which must be preset at the beginning of the measurement procedure. Measurements are performed in a few seconds and basic accuracy for Q is of the order of 10 percent.

**Strengths:**

- (1) Versatile - easy to perform measurements at various frequencies
- (2) Fast compared to manually operated bridges
- (3) Measures high-Q devices
- (4) Broad frequency range
- (5) Good accuracy capabilities
- (6) Commercially available

**Weaknesses or Limitations:**

- (1) Uncertainty in Q increases for higher Q values and higher frequencies
- (2) Frequency monitoring required for best accuracy
- (3) Cannot be used to measure low-Q devices directly
- (4) Operator experience required

**References pertaining to the Q-meter:**

[12,13,50,51,52,53,54,55,56]

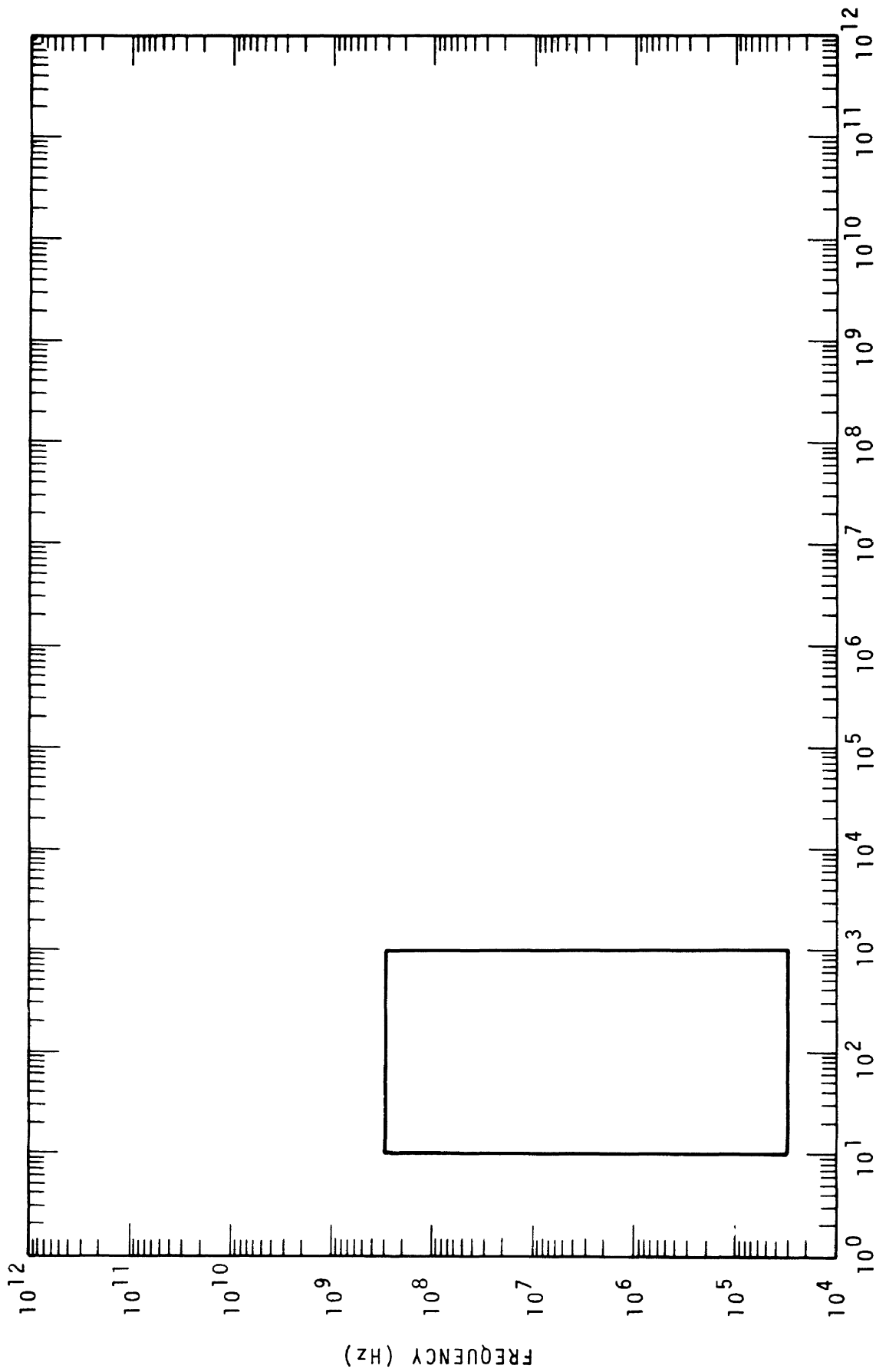

Figure 4-32. Q-meter: Range of Q vs frequency.

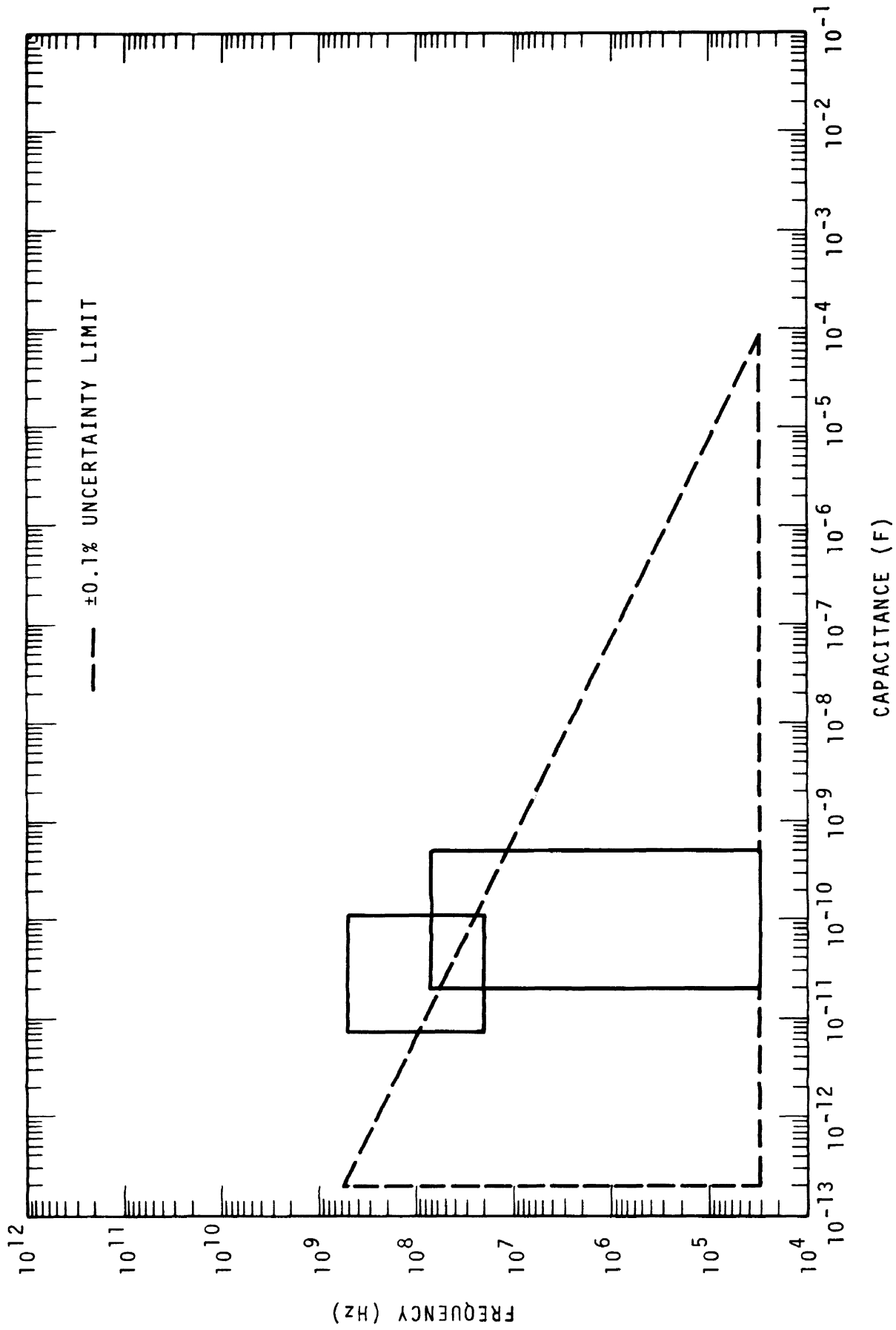

Figure 4-33. Q-meter: Range of capacitance vs frequency.

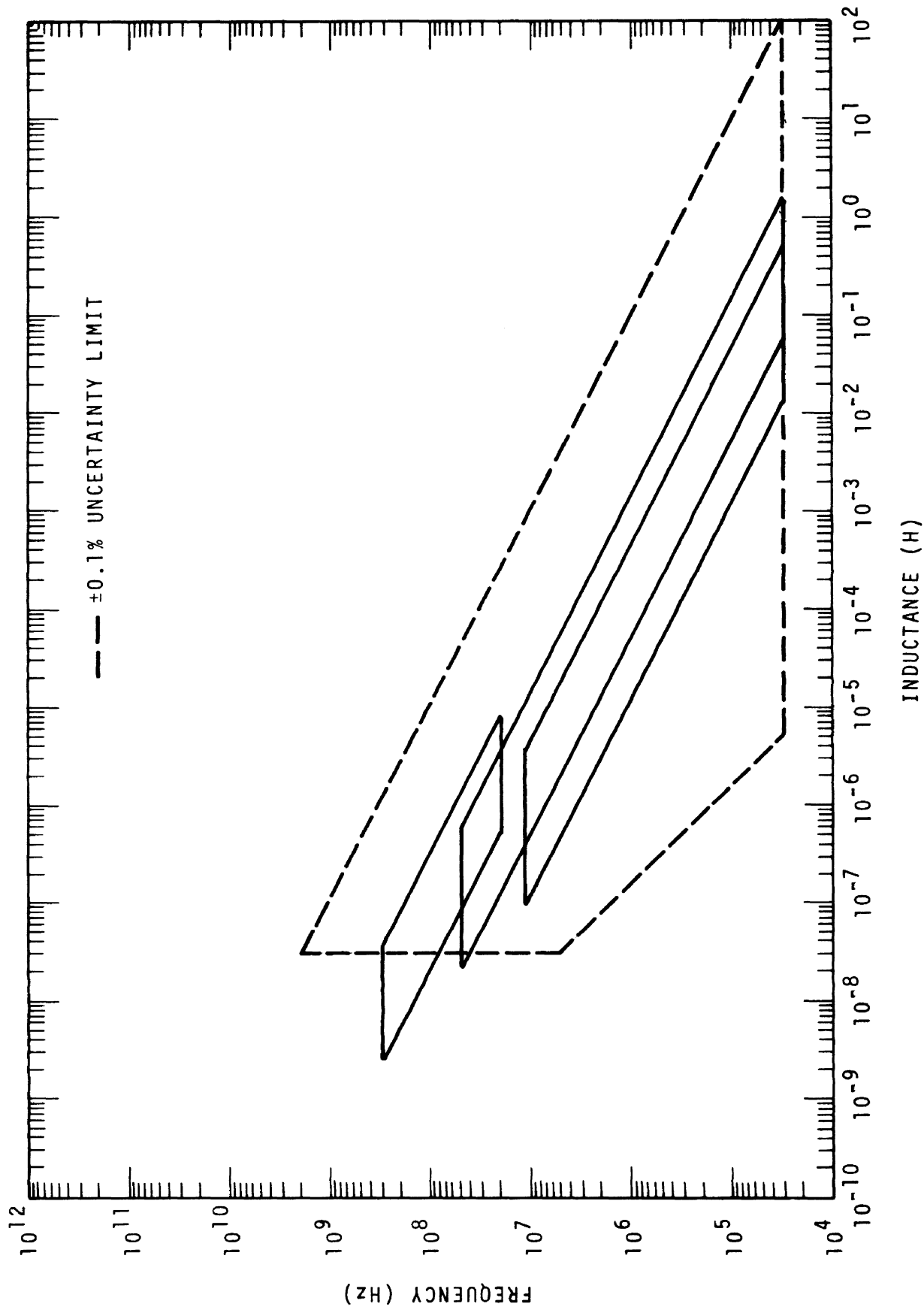
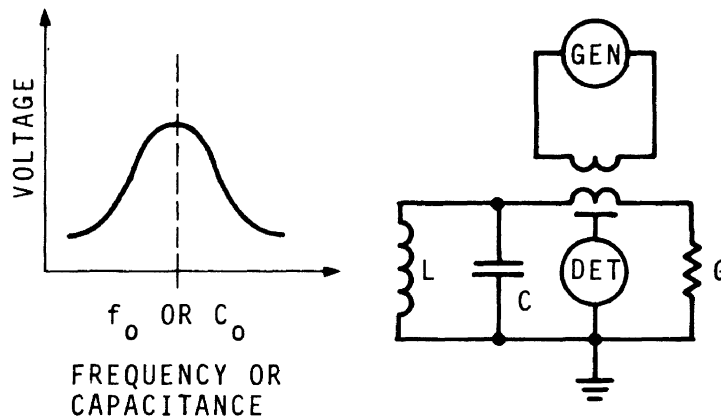

Figure 4-34. Q-meter: Range of inductance vs frequency.



MEASUREMENT EQUATIONS:

$$Q = \frac{C_0}{\Delta C} = \frac{f_0}{\Delta f} \quad (4-24)$$

$$\omega L = \frac{1}{\omega C} \quad (4-25)$$

Figure 4-35.

Range and accuracy for Q measurements:

50 to 10,000 from 1 to 250 MHz with accuracies of the order of  $\pm 1$  to  $\pm 10\%$  under most ideal conditions

Range and accuracy for capacitance and inductance measurement:

These are entirely dependent upon the external standards available for use in the resonant circuit. The

standards are connected externally and are not an integral part of the transcomparator.

Comments:

The operation of this instrument is based upon the principle of parallel resonance or anti-resonance. It is mainly used in standards work and provides for the accurate intercomparison of inductors and capacitors and the measurement of high valued resistances in the 1 to 250 MHz frequency range. Such an instrument is also useful for the measurement of dielectric constant and loss tangent of dielectric materials. The instrument, which has been constructed in many forms by various experimenters, can utilize either the frequency variation or the capacitance variation technique for measuring Q or bandwidth of a parallel resonant circuit. Q is determined by increasing the input voltage by 3 dB after the circuit has been brought to resonance and then detuning either in frequency or capacitance to the original reference voltage level. Q is then  $C_0/\Delta C$  or  $f_0/\Delta f$  where  $\Delta C$  or  $\Delta f$  are the difference between upper and lower half-power points in either capacitance or frequency respectively.  $C_0$  and  $f_0$  are the capacitance and frequency settings at resonance.

This instrument is not available commercially. Its use is probably limited to very specialized applications where other resonance instruments, such as the Q-meter are inadequate. At the National Bureau of Standards a version has been used to intercompare inductors and capacitors with precision sections of coaxial transmission line.

This is definitely not a field instrument. It requires a highly stable and tunable source with more than average power output capability, without which it is no better than a Q-meter. Very high detector sensitivity and stability is also



required. As the  $Q$  of the circuit decreases and the response curve flattens, the accuracy of measurement is impaired, thus limiting the application to high- $Q$  situations. An advantage is that  $Q$  values much above the capabilities of the  $Q$ -meter circuit are measurable, because of the capabilities for high resolution, using either a frequency counter or a very high quality incremental capacitor.

The coupling of the oscillator to the circuit is inductive and largely limits the lower operating frequency to approximately 1 MHz. The detector is capacitively coupled to the circuit to avoid interaction between input and output.

Strengths:

- (1) High accuracy
- (2) Versatile - capable of measurements over wide frequency range and can measure either positive or negative reactance
- (3) Can utilize either frequency variation or reactance variation method

Weaknesses or Limitations:

- (1) Requires highly skilled operator
- (2) Very slow
- (3) Only capable of measuring high- $Q$  devices
- (4) Not available commercially

References pertaining to the Immittance Transcomparator:

[4,8,9,10,11,14]

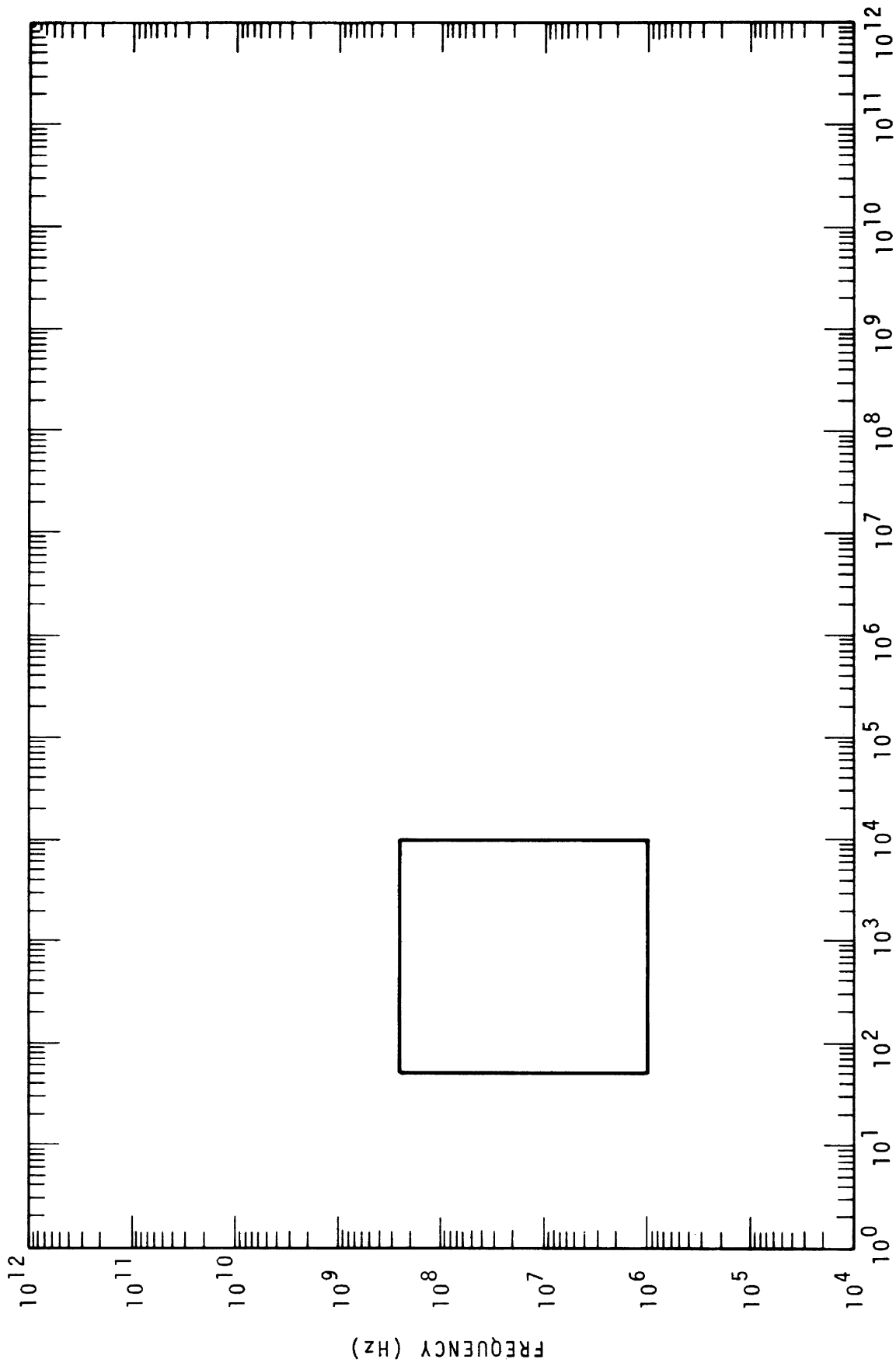
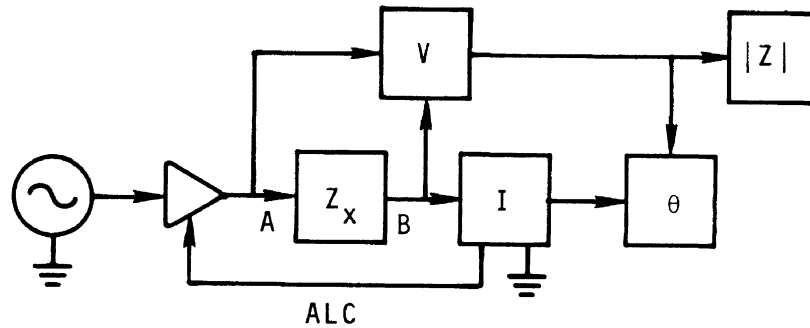

Figure 4-36. Immittance transcomparator: Range of Q vs frequency.

### 4.3. Active Instruments

#### a. Vector Impedance Meter Categories Measured: I



MEASUREMENT EQUATIONS:

$$\bar{Z} = \bar{E}/\bar{I}$$

(4-26)

Figure 4-37.

Range and uncertainty of impedance magnitude measurement:

1 $\Omega$  to 10 M $\Omega$  from 30 kHz to 500 kHz decreasing to 1 $\Omega$  to 100 k $\Omega$  from 500 kHz to 100 MHz; basic uncertainty  $\pm 5\%$ .

Range and uncertainty of phase angle measurement:

0 to  $\pm 90$  degrees from 30 kHz to 100 MHz; basic uncertainty  $\pm 6$  degrees up to 500 kHz and  $\pm 3$  degrees from 500 MHz to 100 MHz. For higher frequencies additional uncertainties must be added which are functions of frequency and impedance magnitude of the unknown.

Range and uncertainty for resistance measurement:

Same as for Impedance magnitude.

Range and uncertainty for inductance measurement:

5  $\mu$ H to 1 H at 30 kHz decreasing to 1 nH to 10  $\mu$ H @ 100 MHz with basic uncertainty of the order of  $\pm 7$  percent over entire frequencies for inductances with  $Q > 10$ .

Range and uncertainty for capacitance measurement:

0.5 pF to 5  $\mu$ H @ 30 kHz decreasing to 0.03 pF to 0.3  $\mu$ F @ 500 kHz with basic uncertainty of  $\pm 7\%$ . From 500 kHz to 100 MHz the range limits also decrease with frequency. Over this range the capabilities are 3 pF to 0.3  $\mu$ F at 500 kHz and 0.02 pF to 2000 pF at 100 MHz. Basic uncertainties about  $\pm 7\%$ .

Comments:

These are among the more recent instruments to appear and no foreign versions have yet been introduced. The main advantages are much increased speed and convenience over more conventional instruments such as bridges. However, gaining these advantages requires some sacrifice in accuracy. A coaxial probe is used to connect the unknown to the measuring circuit, and impedance magnitude and phase angle are directly read on panel meters. The main applications are in design work, or perhaps in production testing, but not in standards work where highest accuracy is required. The vector impedance meter is also useful for "in situ" measurements. Calibration of these instruments is made difficult because of the ambiguity in defining the measurement reference plane. Depending upon whether a low impedance or a high impedance is being measured,

either a constant current or a constant voltage is introduced into or across the unknown and the resulting voltage or current detected. Complex impedance is displayed in polar form. No initial balancing is required and no calculations are necessary unless the measurement results are desired in rectangular form. Measurements at different frequencies are quickly made because only one dial adjustment is required. This is in contrast to a bridge measurement where both generator and detector tuning are required at each frequency. In this sense then the vector impedance meter is a broadband instrument. The measurement range mentioned here is covered by two instruments, one operating below 500 kHz and the other above 500 kHz. For measurements with the lower frequency instrument, measurements must be performed with the unknown isolated from ground potential.

**Strengths:**

- (1) Fast
- (2) Very little operator experience required
- (3) Versatile - excellent for investigating behavior of an unknown over a range of frequencies
- (4) Commercially available
- (5) Wide frequency range; wide range of measurement

**Weaknesses or Limitations:**

- (1) Low accuracy
- (2) Accuracy difficult to verify especially at higher frequencies

**Reference pertaining to the Vector Impedance Meter: [57]**

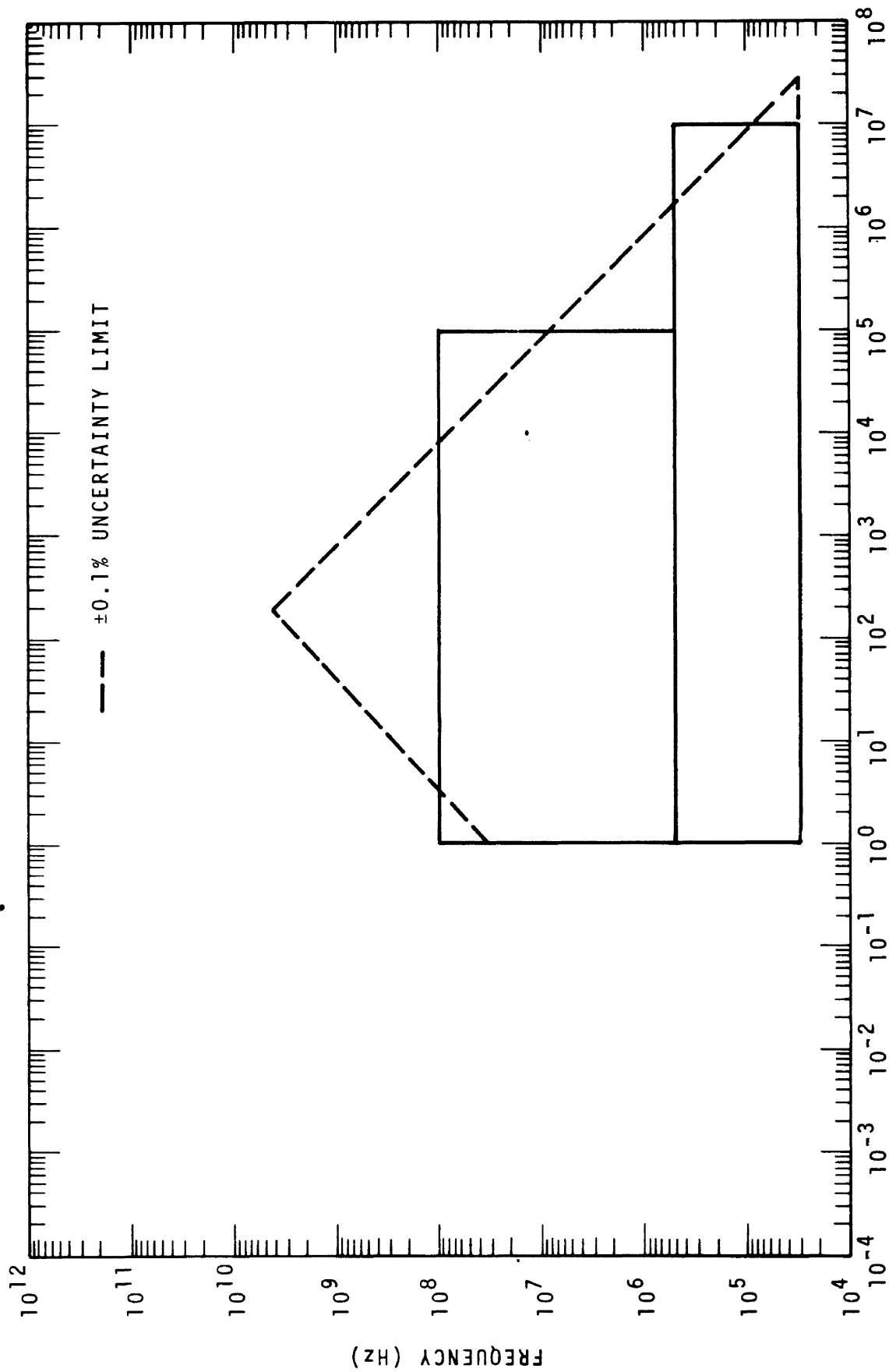

Figure 4-38. Vector impedance meter: Range of resistance or impedance magnitude vs frequency.

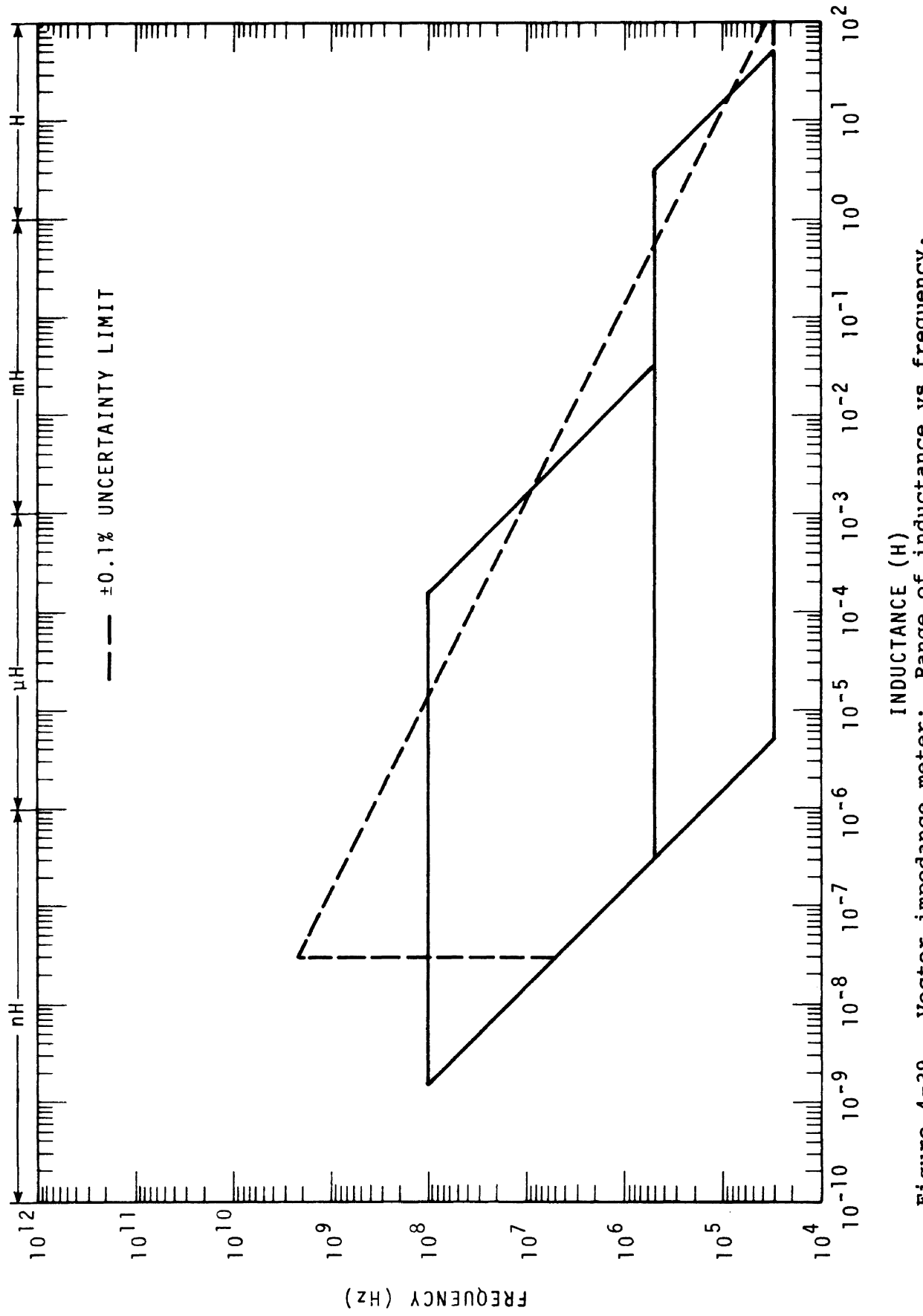

Figure 4-39. Vector impedance meter: Range of inductance vs frequency.

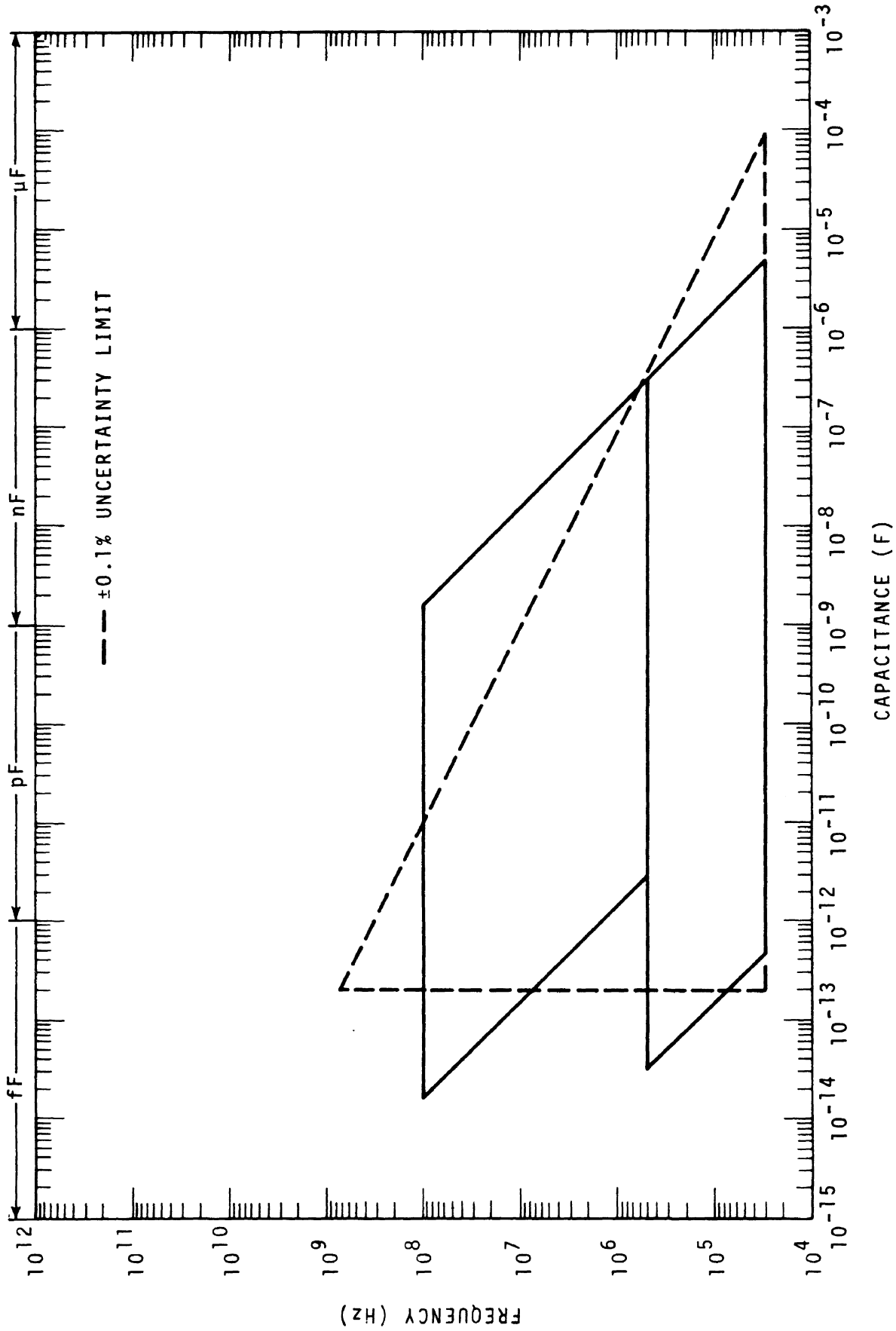
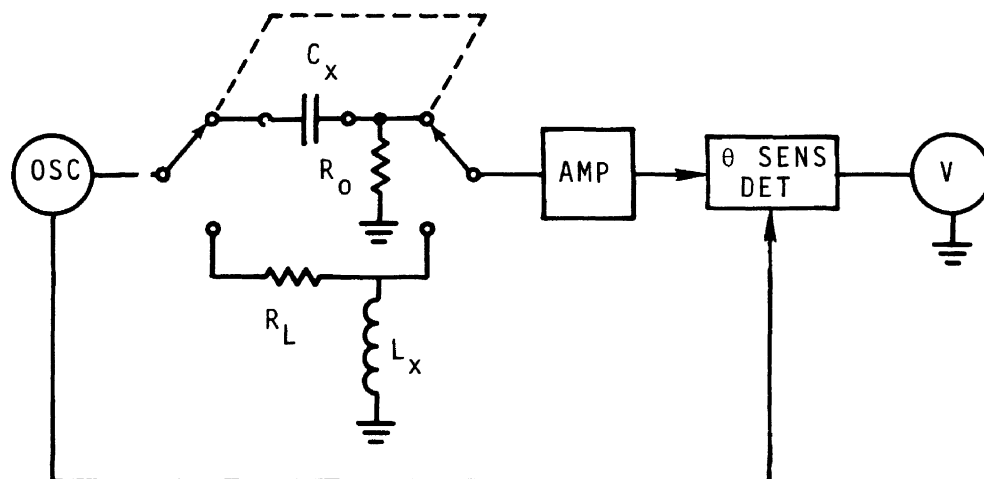

Figure 4-40. Vector impedance meter: Range of capacitance vs frequency.





REFERENCE VOLTAGE

MEASUREMENT EQUATIONS:

$$\frac{V_o}{V_i} \approx L \quad (4-27)$$

$$\frac{V_o}{V_i} \approx C \quad (4-28)$$

Figure 4-41.

Range and uncertainty for inductance:

10  $\mu$ H to 10 mH at 100 kHz with basic uncertainty of  $\pm 0.5\%$ ; 1  $\mu$ H to 1 mH at 1 MHz with basic uncertainty of  $\pm 0.5\%$ .

#### Range and uncertainty for capacitance:

10 pF to 0.01  $\mu$ F at 100 kHz with basic uncertainty of  $\pm 0.5\%$ ; 1 pF to 1000 pF at 1 MHz with basic uncertainty of  $\pm 0.5\%$ .

#### Comments:

The L-C meter is limited to measurement at fixed frequencies and does not provide information as to the resistance or conductance of the tested reactance. However, the convenience of the meter readout combined with its relatively good accuracy, speed and the additional capability for either two-terminal or three-terminal capacitance measurements fulfills many measurement requirements, especially in quality control or component selection. This instrument also permits measurement under bias conditions and "in situ" measurements. The L-C meter is often equipped to provide a linear dc output which is proportional to the measured inductance or capacitance and therefore it may be used to drive an X-Y plotter. No initial balancing operations are required and minimal operator skill is required. The instrument is capable of serving well in the role of a comparator and is relatively inexpensive when compared to other impedance instruments.

#### Strengths:

- (1) Fast
- (2) Little operator experience required
- (3) Relatively good accuracy
- (4) Relatively inexpensive
- (5) Easily portable
- (6) Easy to calibrate
- (7) Has linear d.c. output for automatic data processing applications

Weaknesses or Limitations:

- (1) Operates only at fixed frequency
- (2) Does not measure resistance or conductance; limited to capacitance and inductance

Reference pertaining to the L-C Meter: [5]

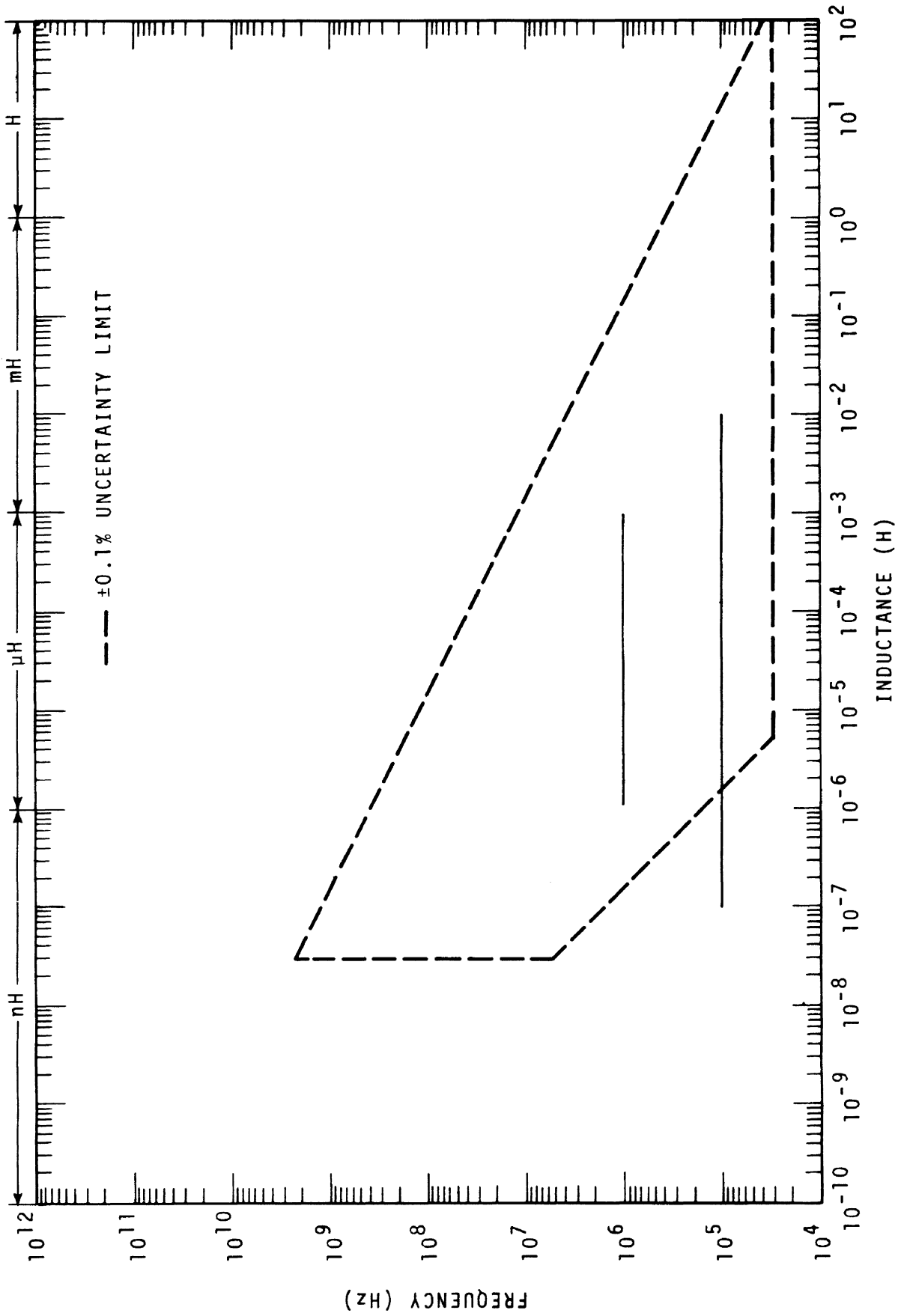

Figure 4-42. L-C meter: Range of inductance vs frequency.

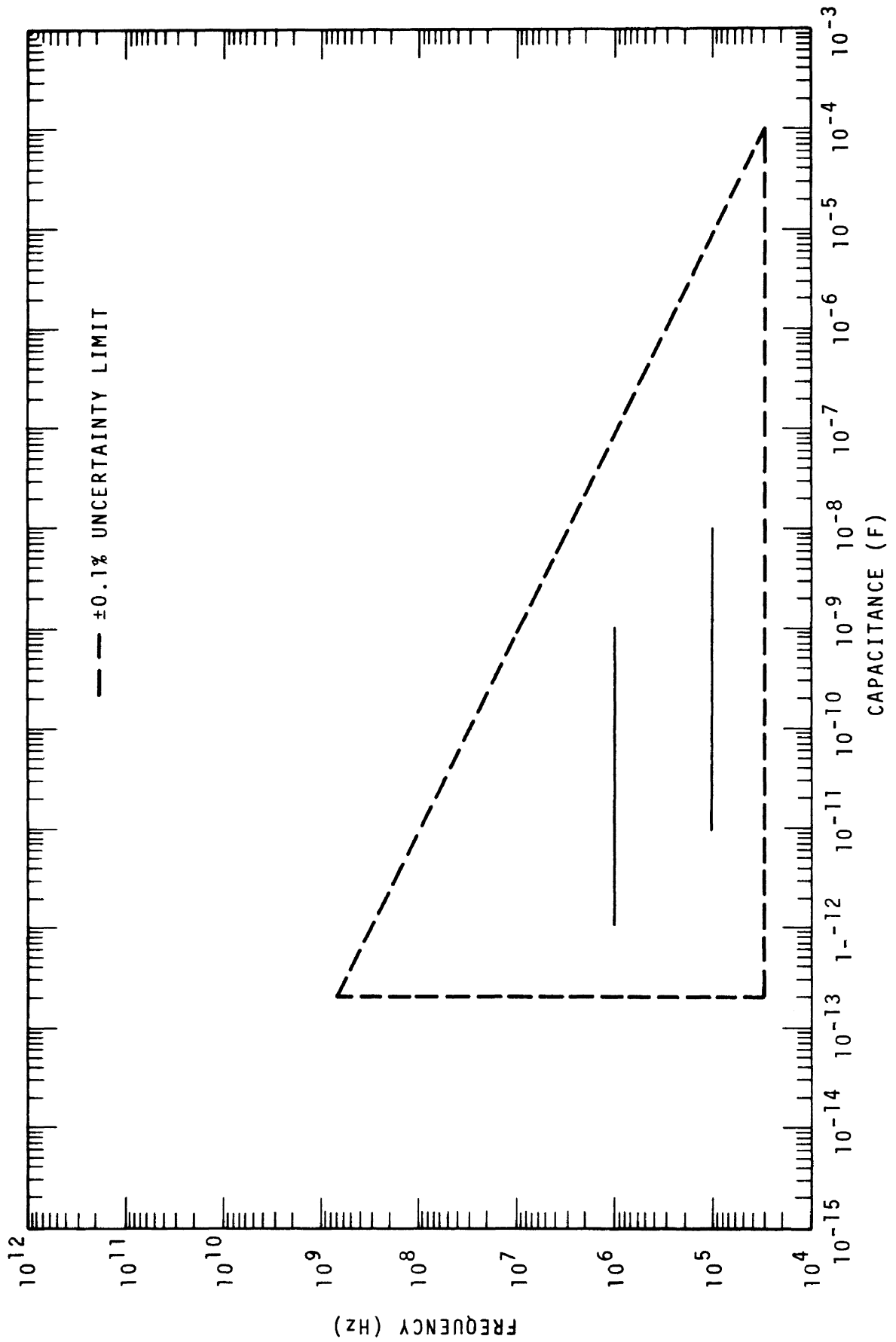

Figure 4-43. L-C meter: Range of capacitance vs frequency.

c. Vector Voltmeter

Categories Measured:  
A,B,C,D,E,F,G,H,I

Although not specifically designed for the measurement of impedance, this instrument can occasionally provide unique solutions to impedance measurement requirements which might otherwise be awkward and difficult by more conventional means.

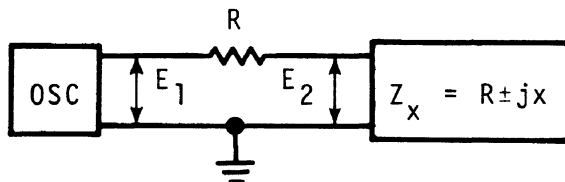

Figure 4-44.

The measurement principle is illustrated by the figure where current from the oscillator flows through a resistor of some known value,  $R$ , to the unknown load impedance,  $Z_x$ . A vector voltmeter is used to measure the complex quotient of the voltages,  $E_2/E_1$ . This data may be plotted on a Smith chart which has been normalized to the value of  $R$ , and thus information on VSWR and complex impedance of an unknown may be determined very quickly over wide frequency ranges.

The vector voltmeter has also been used in conjunction with directional couplers to perform measurements on remotely located or inaccessible loads. These methods are usable over a frequency range from 1 MHz to 1 GHz. Uncertainties vary widely over such a range but  $\pm 5\%$  in impedance magnitude and

$\pm 2$  degrees in phase angle are typical. Best results are obtained when the unknown impedance is near the value of R.

**Strengths:**

- (1) Fast
- (2) Wide frequency range
- (3) Wide range of impedances measurable
- (4) Good for field measurements
- (5) No special equipment required (all components usable for wide variety of applications)

**Weaknesses and Limitations:**

- (1) Low accuracy
- (2) Operator experience and training necessary

References pertaining to the Vector Voltmeter: [6,7]

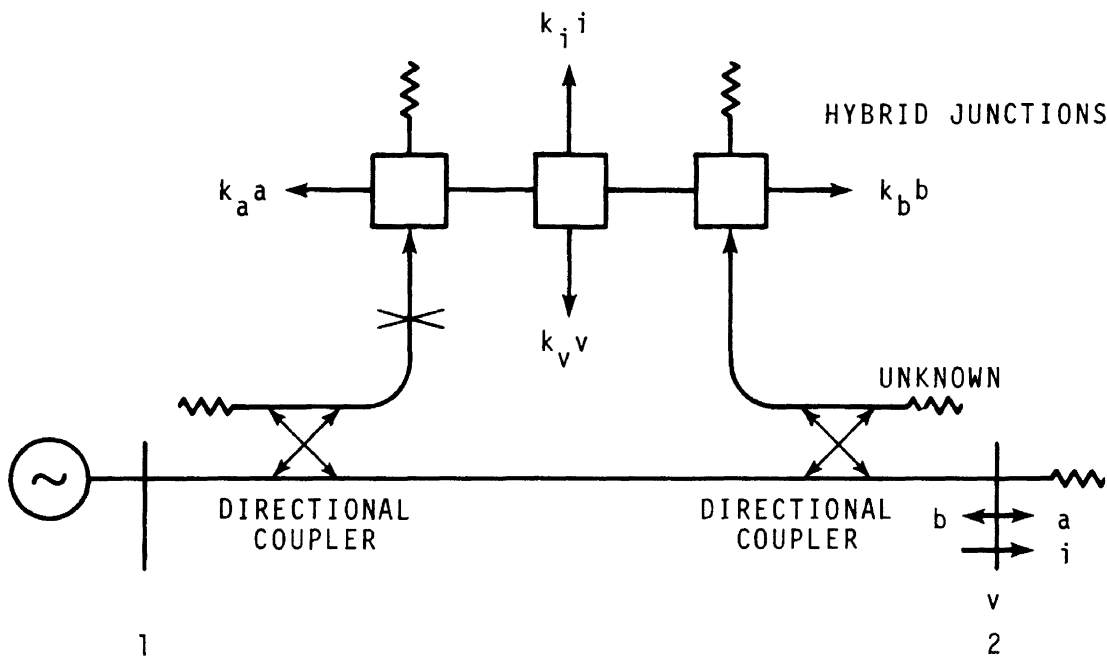

Figure 4-45.

The six port is probably the most recent approach to the measurement of impedance. It offers many exciting possibilities not realizable by other methods or instruments. The concept is based upon the law of cosines and all necessary information to determine the unknown impedance is obtained through the measurement of magnitudes of output voltages. The diagram above is only one of several different configurations which may be used to form a six port network. The principal limitations on the six port are the directivities which can be achieved in directional couplers and hybrid junctions and the bandwidths over which the directivity of these devices can be sustained. Figure 4-46 shows the measurement accuracy attainable as a function of directivity.



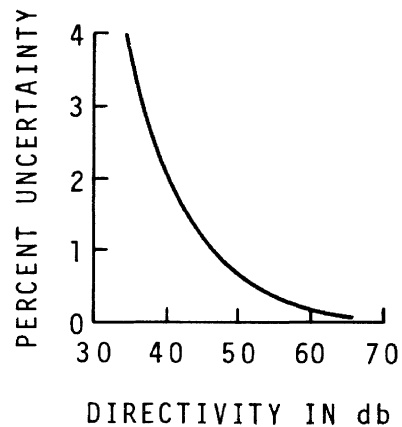

Figure 4-46. Measurement of 6-port coupler vs directivity of hybrid junctions.

Higher directivities are attainable by the use of tuning but this of course slows the measurement process. Directional couplers and hybrid junctions are most frequently thought of as being distributed parameter elements designed for use at frequencies above the normal range where lumped parameter measurements are made. In recent years these devices have been developed for use at lower frequencies making the 6 port feasible for lumped parameter impedance measurement. Because of its relative simplicity, the availability of component parts, its potential for automation, and the fact that impedances from short-circuit to open-circuit are measurable over broad frequency ranges the 6 port appears to have the best potential for approaching the ideal instrument.

Strengths:

- (1) Broadband
- (2) Versatile

- (3) Can be assembled from commercially available components
- (4) Redundancy of measurement facilitates calibration and self-checking
- (5) Adaptable to automated measurement
- (6) No requirement to measure phase directly; all parameters determined by measurement of voltage magnitudes
- (7) Capable of measuring both active and passive impedances
- (8) Usable for measuring other quantities such as voltage, current, power and phase.

**Weaknesses :**

- (1) Accuracy capability limited by directivity of hybrid junctions
- (2) Requires experiences and knowledgeable operator

References pertaining to the 6-port Coupler: [71]

#### 4.4. Comparator Instruments

As mentioned in 3 D, almost any null or resonance or active type instrument may serve as a comparator. For specific and detailed examples of the use of instruments in the role of a comparator (see reference 13) in which a Q-meter is used as a comparator in the calibration of Q-standards, or see reference 17 wherein the use of an admittance ratio bridge is used as a comparator for calibrating capacitance standards at 100 kHz, 1 MHz and 10 MHz.

References pertaining to the Comparator method: [13,16,17]

## 5. MEASUREMENT TIPS AND TECHNIQUES

The following are a few simple steps and precautions which can be observed to produce better measurement results.

- (1) Use precision coaxial connectors wherever and whenever possible, especially in standards work. If it is not possible to use precision coaxial connectors, the next choice should be a non-precision coaxial connector. Unshielded connector arrangements such as banana jacks and plugs should be avoided except in circumstances where there is no other choice.
- (2) Leads should be kept as short as possible because of the residual impedances they add to the measurement or to the measured circuit. When it is necessary to utilize unshielded leads and connectors, the high potential leads should be kept as far from grounded objects as possible in order to minimize stray capacitance effects.
- (3) Depending upon whether an impedance or an admittance measurement is being made, the impedance of the short-circuit reference or the admittance of the open-circuit reference should be kept as small as possible to avoid errors in measurement of absolute values.
- (4) Keep generator voltages as low as possible while preserving adequate detector sensitivity. This reduces the possibility of thermal drift or damage either to instruments or components being measured. Most impedance and admittance bridges operate very well on two volts or less.
- (5) Tuned detectors should be used for maximum sensitivity and also to avoid the need for large generator voltages to produce adequate sensitivity.
- (6) Impedance matching between signal source and bridge, or between bridge and detector can be a significant factor in improving sensitivity. Input and output impedances

of generator detectors and bridges may vary widely so that impedance matching may produce substantial improvements in measurement system operation.

- (7) Use a frequency counter to check the frequency of the source voltage. This is especially important where the readout of the bridge is a function of frequency, or where the impedance of the device being measured is frequency dependent. (for example a device which is at or near self-resonance at the measurement frequency).
- (8) Keep contact surfaces clean through the use of low-residue solvents. Cleanliness is always good practice.
- (9) Store and operate instruments in a clean, dry environment. Treat the instrument right and it will return the favor. Avoid exposure to environmental extremes, and allow time for temperatures of instruments and components to reach equilibrium conditions.
- (10) Do not assume that the effect of a long lead between bridge and unknown can be balanced out by the bridge circuit. Such an assumption can result in large measurement errors. Make all measurements as near to the bridge terminals as possible, and then correct for lead effects. A long lead or cable can be considered as an adapter, and corrections can be made for it by using the equations to be found in Section 9.
- (11) Consider the alternative of performing measurements at other frequencies. With the exception of inductors and capacitors which are operating at frequencies near self-resonance, many components are not frequency dependent to the first order. As a result, it is often satisfactory to perform measurements at frequencies quite far from actual application frequencies. Such an alternative is sometimes useful when measuring instruments which operate at the actual application frequencies, are not available.

As an example suppose that capacitors with low dissipation factor are needed at 30 MHz. Although capacitance bridges which measure dissipation factor accurately at that frequency are not available, it may be entirely satisfactory to use bridges which operate at 1 MHz or even 1 kHz.

## 6. STANDARDS

### 6.1. General Comments

Impedance standards for the lumped parameter range are highly developed and directly relatable to the prototype units of length and time (reciprocal frequency). Accuracies of the order of 0.01 to 0.1 percent are feasible over a wide range of frequencies and values as seen by the graphs which accompany Section 1. Unfortunately it is very difficult to utilize these standards without appreciable loss of accuracy because of connector or interface problems. Impedance standards, in order to possess the best accuracy, must be equipped with precision coaxial connectors. Most measuring instruments on the other hand are not equipped with such connectors so that the best standards cannot be connected directly to them. This requires the use of adapters with a resulting loss of accuracy which varies with frequency, impedance magnitude and phase angle. It follows then that the proper evaluation and use of adapters is an important part of accurate impedance measurement. See Section 9.

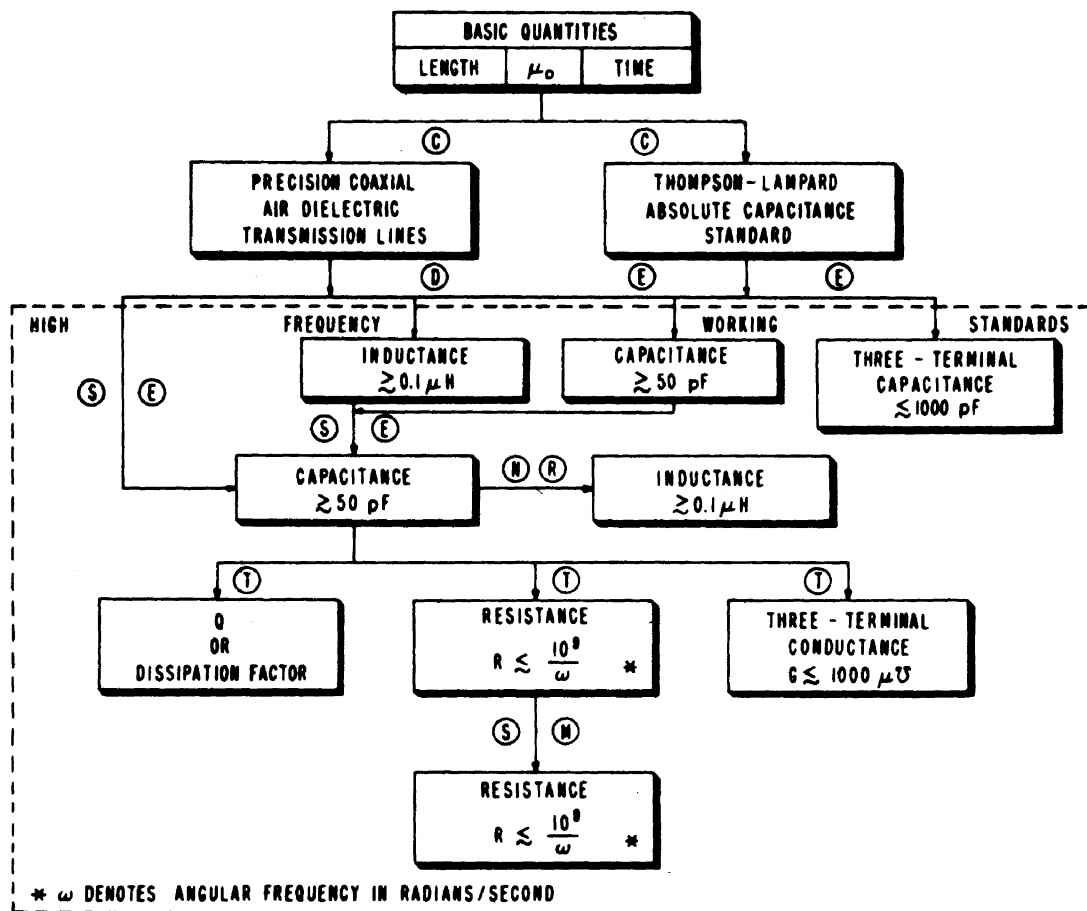

- |                              |                                     |
|------------------------------|-------------------------------------|
| (C) COMPUTATION              | (N) NEGATIVE CAPACITANCE EQUIVALENT |
| (D) DIRECT COMPARISON        | (R) RESONANCE TECHNIQUE             |
| (E) EXTRAPOLATION            | (S) SERIES TECHNIQUES               |
| (M) MAXWELL IMPEDANCE BRIDGE | (T) TWIN-T CIRCUIT                  |

Figure 6-1. Derivation of NBS immittance standards.



Figure 6-1 shows how the NBS standards for high frequency immittance are derived. These standards together with various null and resonance instruments are used to provide calibration services which can be found listed in Reference 60.

Good standards may be purchased from a number of companies both domestic and foreign. Some of these commercial standards are equipped with precision coaxial connectors. The best accuracies may be achieved for those having precision coaxial connectors but even in such cases some accuracy degradation must be accepted when a transition is made to non-precision connectors.

## 6.2. Why Are Impedance Calibrations Expensive?

In order to establish the most efficient, inexpensive and accurate calibrations, it is necessary to adhere to some basic initial requirements. For lumped parameter impedance this means that specific calibration frequencies, impedances and connector types would have to be chosen initially, to the exclusion of all others. Comparator techniques and statistical control can then be used to best advantage in providing calibrations. Such an ideal situation does not exist in the case of impedance standards in the lumped parameter range. Attempts to establish calibration services for specific items have not received sufficient use to be termed successful. In the calibration requests received by NBS, frequencies, impedance values and connector types vary so widely that almost every calibration must be treated as a special problem. When a standard, received for calibration, must be treated as unique rather than as a member of a large group of like standards, calibration is more expensive. Therefore it is desirable to extend the time between recalibrations of a particular standard.

### 6.3. Keeping Calibration Costs Down --- A Tip On Maintaining Standards

While it is true that a resistor, an inductor, or a capacitor may change in value as the frequency is varied, it is also true that if a good impedance standard is stable at one frequency, it can be expected to be stable at all other frequencies, so long as it is not subjected to adverse conditions. This fact can be used to avoid overfrequent need for calibrations. Once an impedance standard is calibrated at a high frequency, and its absolute value determined, it can be monitored at lower frequencies periodically to determine whether or not its value has remained constant. Measurements at dc or audio frequencies are capable of higher accuracies than are higher frequency measurements because the effects of residual impedances such as the series inductance of a capacitor or the shunt capacitance of an inductor are much less significant. Consequently, measurements at lower frequencies frequently can be made more quickly than those at higher frequencies while still maintaining equivalent accuracies. Thus it is useful to monitor high frequency impedance standards at low frequencies, or at dc in the case of resistors, as a test to determine high frequency stability. If the dc or low frequency value is unchanged, and if no signs of physical damage or mistreatment are present, it is a good indication that the high frequency value is also unchanged. These are not infallible rules, however, so that occasional recalibration at high frequencies is desirable.

### 6.4. What To Look For In Choosing A Standard

Presented here are some general criteria regarding the characteristics necessary in a good standard. In choosing those characteristics it is assumed that the standard will be sent to NBS for calibration with the objective of transferring the

maximum practical accuracy and reliability from NBS to the user. Not all of these characteristics are to be found in commercially available standards, a notable case being inductance standards which are equipped with precision coaxial connectors. Although standards falling short of these criteria are accepted for calibration, it is merely good measurement practice and economy to use the best standards available. NBS does not check the items it receives to ascertain their conformance to all of these requirements, and rejections are only made in extreme cases of obvious instability or unreliable performance.

<u>Characteristic</u>	<u>Resistor</u>	<u>Capacitor</u>	<u>Inductor</u>
Temp Coeff.	<10 ppm/° C	<20 ppm/° C	<30 ppm/°C
Q	<10 <sup>-2</sup>	-----	>10 <sup>2</sup>
Dissipation Factor	-----	<10 <sup>-3</sup>	-----
Residual Impedance	for R<1kΩ, L <sub>s</sub> <10nH for R>1kΩ, C <sub>p</sub> <5 pF	L <sub>s</sub> <10 nH	C <sub>p</sub> <10 pF
Long term stability	0.05%/year	0.01%/year	0.01%/year
Power Rating	1 watt min.	-----	-----

In all cases, standards should be well shielded, of rugged mechanical construction and preferably equipped with precision coaxial connectors.

All impedance standards and impedance components exhibit changes in value with changes in frequency because of the presence of residual impedances. Capacitors show an increase because of the series inductance in the leads, and inductors do likewise because of the shunt capacitance. Resistors also vary with frequency but in a more complicated way depending upon whether it is a large or a small resistor, whether it is considered in a series or a parallel sense and which residuals predominate. As a general rule regarding the upper frequency limit at which a standard should be used, it

is not advisable to rely on any standard to an uncertainty better than 1 percent at any frequency above that where the value departs from the nominal (dc or low frequency) value by more than 10 percent.

#### 6.5. Coaxial Lines

In choosing standards or designing measurement procedures, the use of precision coaxial, air-dielectric transmission lines should not be overlooked. When terminated in a short circuit they provide excellent standards for small inductance values or when terminated with an open-circuit of well known characteristics, they may be used for small value capacitors standards. In either of these applications the inductance and capacitance values are calculable from physical dimensions and known material properties.

Excellent use can be made of these lines at higher frequencies in the role of an impedance transformer to extend the usefulness of other impedance standards. See equations 9-1 and 9-2 under Section 9 for appropriate equations for use in such circumstances.

References pertaining to Standards: [15,40,58,59,60,61,62,63,  
64,65,66,67,68]

## 7. RANGE EXTENSION

The frequency ranges over which impedance measuring instruments are designed to operate are usually not extendable for a number of reasons, but it is very often possible and desirable to extend the ranges for impedance parameters through the use of external standards. This is done by combining an unknown with some standard or other well known impedance in a manner such that the resulting impedance or admittance falls within the measurement range of an available instrument. In general there are two range extension techniques which may be used. One is to combine the unknown and some known impedance in a series configuration. The other scheme is to combine the unknown and some known impedance in a parallel configuration.

### 7.1. The Series Configuration

The basic characteristic of a series circuit is that all of the current passes through each circuit element. Such a circuit is shown in figure 7-1.

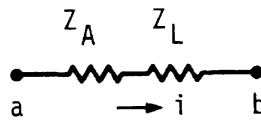

Figure 7-1.

Here the voltage across the circuits is from Kirchoffs Law:

$$V_{ab} = iZ_i = iZ_A + iZ_L \quad (7-1)$$

where  $Z_i$  is the total input impedance and  $Z_A$ , and  $Z_L$  are the impedances of the standard and the unknown respectively. From this relationship it follows that

$$Z_L = Z_i - Z_A. \quad (7-2)$$

If  $Z_T$  is the upper limit of the impedance measuring range of a bridge and  $Z_L$  is an unknown impedance which is larger than  $Z_i$ , it would appear to be a very simple matter to insert some known value,  $Z_A$ , in series with  $Z_L$  to make the combination fall within the range of the instrument.

This could be the case where it is required to measure an inductance too large for a bridge and a capacitor of known value is inserted in series. Considering only the reactances this would give

$$X_L = X_i - X_A \quad (7-3)$$

in the circuit of figure 7-2,

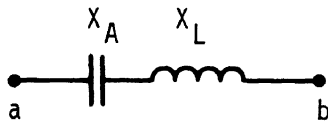

Figure 7-2.

the capacitor, represented by  $X_A$ , would have a reactance less than that of the unknown inductance,  $X_L$ , at the measurement frequency.

Another situation which lends itself to the use of an external series impedance element of known value for range extension purposes, is the measurement of large capacitances out of the normal range of an admittance bridge. Figure 7-3 illustrates this case, where  $C_L$  is the unknown whose value is to be determined and,  $C_A$ , is the capacitor of known value.

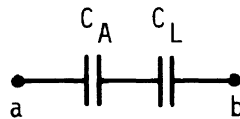

Figure 7-3.

Here the series approach of Equation (7-1) yields the expression:

$$C_i = \frac{C_A C_L}{C_A + C_L} \quad (7-4)$$

which when solved for  $C_L$  yields:

$$C_L = \frac{C_i C_A}{C_A - C_i} \quad (7-5)$$

The foregoing two simple examples do not tell the whole story however because the series circuits from which the relationships were derived do not accurately represent the true picture that exists with grounded two-terminal measurements. Now that the principle has been illustrated, a closer examination is in order. A more valid circuit than figure (7-1) would be the following:

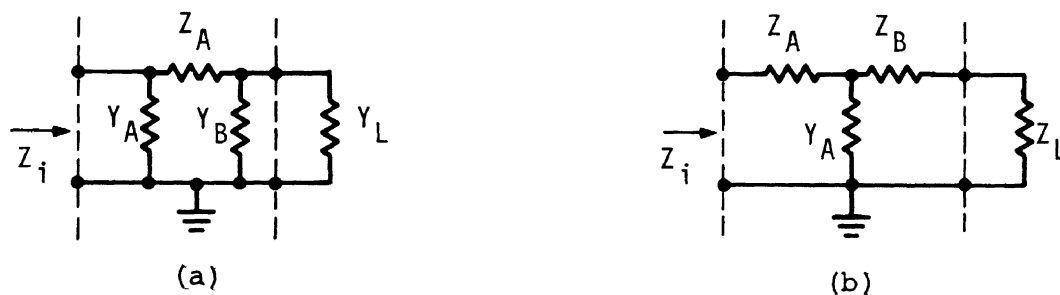

Figure 7-4.

The series element must be shown as an equivalent-pi or equivalent-tee network because of the shunting capacitances which are present in the actual circuit. Failure to treat the series elements in this manner can seriously degrade the measurement accuracy of the procedure. Evaluating the elements of the equivalent pi or tee-network for the series element is done by making impedance and admittance measurements at each port of the series element with the opposite end open-circuited and short-circuited. Once this is done, the equations of 9-3a and 9-3b may be used to arrive at the desired result.

- References: [59] A discussion of the use of series techniques and transformer techniques for range extension.
- [69] An exhaustive treatment of the use of series elements in immittance measurement.



For convenience, equation 9-3 is repeated here:

$$Y_i = Y_A + \frac{Y_B + Y_L}{Z_Z(Y_B + Y_L) + 1} \cdot \quad (9-3)$$

Equation 9-4 is:

$$Z_i = Z_A + \frac{Z_B + Z_L}{Y_A(Z_B + Z_L) + 1} \cdot \quad (9-4)$$

Note that if the shunt admittances are set equal to zero, equations (9-3) and (9-4) reduce to (7-2).

The most nearly ideal type of series element which can be employed for range extension is a section of precision coaxial air dielectric transmission line placed between the bridge and the unknown to be measured. These procedures become especially versatile at higher frequencies where a relatively short section of coax line represents an appreciable portion of a wavelength. Figure (9-1) and equations (9-1) and (9-2) are appropriate for applications of this type.

Before leaving the subject of the use of series elements in range extension, several additional comments are in order:

- (1) Because precision coaxial connectors and improved methods for evaluating the open-circuit admittances of various connectors (see 9-4) are now available, improved accuracy with series elements is realizable.
- (2) Where the reactance of the series element is of opposite sign to that of the unknown, frequency should be accurately known and controlled.
- (3) Unless coaxial elements are used, the highest measurement accuracy cannot be assured.

- (4) Even under ideal circumstances, the accuracy resulting from the series technique will be poorer than the basic accuracy of the bridge used in making the required measurements.

## 7.2. The Parallel Configuration

In contrast to the series circuit it is the input voltage which is common to each of the elements in a parallel circuit:

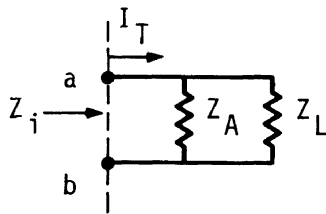

Figure 7-5.

From Kirchoffs Law the total circuit current is:

$$I_T = \frac{V_{ab}}{Z_i} = \frac{V_{ab}}{Z_A} + \frac{V_{ab}}{Z_L} .$$

Dividing through by  $V_{ab}$  and replacing impedances by admittances, this becomes

$$Y_L = Y_i - Y_A \quad (7-6)$$

There are a number of applications for range-extension through the use of parallel components. Here are some examples:

- (1) When performing measurements using parallel resonance methods a capacitor of known value can be placed in

parallel with an unknown inductor to extend the range of the instrument.

Q-meters, with their extra pair of terminals are well adapted to such applications and it is thereby possible to effect considerable extension of the measurement range with very little difficulty.

- (2) Impedance bridges may be used to measure resistors out of their normal range by placing them in parallel with other known resistors whose values fall within the normal range of the bridge.

Measurement accuracy is reduced with the use of parallel range extension techniques because of impedance uncertainties introduced by the connection. Coaxial tees introduce mutual impedances at their junctions and also add undesirable residuals to the components connected to them. In general the same comments regarding accuracy in the use of series elements for range extension also apply to parallel range extension.

## 8. GENERATORS AND DETECTORS

A typical setup for measuring impedance is illustrated by the following diagram:

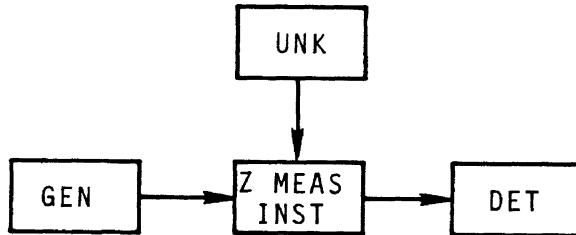

Figure 8-1.

In many instances the entire system will be an integrated package so that no decisions or selections with respect to the generator and detector need be made. In still other situations the impedance measuring instrument is a separate chassis requiring that a generator and detector be supplied externally. Either situation has advantages and disadvantages relative to the other which bear careful consideration. First, consider the separate impedance measuring instrument which does not include a generator and a detector; and the following advantages and disadvantages:

### Advantages

- (1) Generator and detector are not "tied up" in one system so that they are available for use in other measurement applications. This is economical from the standpoint of maximum utilization of equipment.

- (2) Impedance measuring instrument may be acquired for less expense if suitable generator and detector are otherwise available.

#### Disadvantages

- (1) More setup time required because generator and detector must be procured and connected.
- (2) More operator experience required because the metrologist must be informed as to generator and detector requirements; be able to recognize system problems such as leakage inadequate sensitivity, etc.

Next consider the packaged system and its inherent advantages and disadvantages:

#### Advantages

- (1) Very short setup time
- (2) Little or no operator experience necessary to assemble the measurement system
- (3) Generator, detector and impedance measuring circuit all especially arranged to provide optimum performance, i.e., generator and detector well-shielded, providing adequate frequency stability, sensitivity, etc.

#### Disadvantages

- (1) Higher acquisition cost for packaged system
- (2) Generator and detector "tied up" and unavailable for use elsewhere.

The generator and detector subject may be pursued from a slightly different aspect which is mainly concerned with requirements of null and resonance methods for measuring impedance. For a null method the following general requirements are important:

- (1) Generator frequency stability - Should be stable and accurate to 1 part in  $10^4$  but particular attention should be paid to this requirement where the unknown being measured is frequency sensitive or where a frequency term appears in the balance equations for the instrument.
- (2) Generator output - Usually an output of 2 volts into 50 ohms or something in the vicinity of 100 milliwatts is adequate and this may be considerably less where good detector sensitivity is provided. It is good practice to use the minimum generator voltage possible to avoid the possibilities of damage or thermal drift in either the instrument or the unknown. Voltage level stability is very rarely important except where the unknown may be current or voltage sensitive as in some dielectric or magnetic materials measurements.
- (3) Shielding - Coaxial leads should be used between generator and bridge and between bridge and detector in all cases. Inadequate shielding can be detected if a difference in the detector null indication is noticeable with the generator off or on.

- (4) Harmonic content of generator - The importance of generator harmonics depends upon the selectivity of the detector in rejecting signals at other than the measurement frequency. Most good signal generators will have harmonics 30 dB below the fundamental frequency. The use of band pass or low pass filters will help to reject unwanted frequency components.
- (5) Detector sensitivity - Should be adequate to resolve the minimum calibration interval on the dials of the measuring instruments. This is typically a sensitivity of the order of 1  $\mu$ V.
- (6) Logarithmic detector response is desirable because it avoids the necessity of switching ranges as the null is approached.

Communication receivers provide excellent detectors for null measurements because they provide the combination of selectivity, sensitivity, good shielding and logarithmic response. They are also capable of covering a wide frequency range.

For resonance methods, many of the same requirements exist for generator and detector as for null methods with a few very notable exceptions, most of which apply to the generator. Generator requirements for resonance measurements include:

- (1) Frequency stability and accuracy - should be of the order of 1 part in  $10^6$ . This requirement is difficult to fulfill in the case where frequency variation method is being used, because tunable generators with such capabilities are expensive.

(2) Output voltage - Because it is desirable from the standpoint of accuracy to decouple the input and output probes to the maximum extent possible in a resonant type measuring instrument, it is an advantage to have a generator capable of an output of one or two watts at the measurement frequency. This requirement, coupled with the simultaneous requirement for output level stability is a significant reason why resonance techniques are not widely used except in the case of the Q-meter, which utilizes a different insertion technique together with a calibrated detector.

### 8.1. Phase-Sensitive Detectors

Phase-sensitive detectors are an addition to impedance measuring systems which have made possible new applications, the most notable of which is the vector impedance meter. Figure 8-2 is a diagram to illustrate the principle of the phase-sensitive detector.

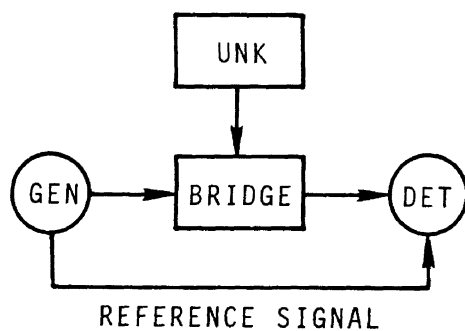

Figure 8-2.



The arrangement is similar to the setup of figure 8-1 except that a reference signal is fed directly to the detector, bypassing the bridge circuit. The detector has the capability of comparing the reference signal with the output or unbalance signal of the measurement instrument and separating the unbalance signal into an in-phase and a quadrature component. At balance of a bridge, both components become zero. However, instruments such as the Q-bridge, the L-C meter and the vector impedance meter all utilize the capabilities of the phase-sensitive detector to achieve a direct reading impedance instrument which does not require the customary balancing operations characteristic of bridges or null instruments. Phase-sensitive detectors also provide greater sensitivity because much smaller signals can be detected in the presence of noise.

## 9. APPLICATION AND EVALUATION OF ADAPTERS

### 9.1. Introduction To The Adapter Problem

In a majority of situations where an impedance measurement is required, there is an interface or connector problem which, if not correctly handled, can contribute serious errors. In the ideal situation, an instrument equipped with a precision coaxial connector at its unknown terminals is used to measure a component which is also equipped with a precision coaxial connector. This, however, is a rare occurrence which probably only happens in standards laboratories. Although efforts have been made to extend the use of precision coaxial connectors [58], [59], the eventual need to use connectors of different diameters (including non-precision ones) remains. Usually the component to be measured cannot be directly attached to the instrument and some sort of a mechanical adaptation is required. The more knowledgeable metrologist will recognize the adapter as a source of error and take steps to compensate as best he can. Others may either ignore the problem entirely, compensate incorrectly, or dismiss it as being of negligible importance which may or may not be true. To make measurements more accurate, and hence more meaningful and useful, there is a need for a better understanding of the problem as well as for better techniques and procedures for dealing with the many and varied types of adapters.

### 9.2. What Is An Adapter?

Let an adapter be defined here as any mechanical arrangement of conductors used to connect two or more electrical devices. This definition of course includes all interconnecting devices such as terminal strips, tube or transistor sockets and many others, and is, therefore, too broad for our present purposes. The only types of adapters to be considered here will be those used for interconnecting two devices, each having a grounded terminal and an ungrounded terminal. Such adapters may range

from the crudest arrangement of interconnecting wires to a sophisticated device carefully designed and manufactured to high tolerances.

Besides the simple mechanical interconnection, an adapter must meet certain electrical requirements. These requirements depend on the intended use of the adapter, the working frequency range and the precision needed in fulfilling various operating conditions. Adapters used in high frequency applications must have good efficiency (small losses) and produce low reflections. For any kind of adapter, the precision of physical dimensions, repeatability of connector parameters, leakage and certain other electrical parameters represent general performance figures.

It is useful to identify adapters by classifying the types of connectors they are used to join. The following is a list of connector types, together with identification symbols and some typical examples of commercial types which are used.

<u>Symbol</u>	<u>Connector Type</u>	<u>Examples**</u>
A	*Precision coaxial	14 mm, 7 mm, 3.5 mm
B	Coaxial symmetrical (sexless)	General Radio Type 874 Rohde & Schwartz Dezifix
C	Coaxial unsymmetrical (sexed)	Type N, BNC, TNC, SMA, etc.
D	Non-coax (unshielded)	banana plugs, banana jacks, interconnecting wires, etc.

\*Precision Coaxial Connectors as defined by IEEE Specifications

This connector classification permits adapter identification as follows:

<u>Symbol</u>	<u>Example**</u>
A to A	GR900 to APC-7
A to B	GR900 to GR874
A to C	GR900 to Type N (male or female)
A to D	GR900-Q9
B to B	GR874 to R and S Dezifix
B to C	GR874 to BNC (male or female)

<u>Symbol</u>	<u>Example *</u>
B to D	GR874 to banana plug or jack
C to C	Type N (male or female) to BNC (male or female)
C to D	BNC to banana jack
D to D	3/4" binding posts to 1" binding posts

\*The mention of specific manufacturers is only intended for purposes of illustration and does not constitute endorsement by NBS of any product.

Not only are there many different classifications (10 listed here) but there is a wide selection of adapters either available commercially or potentially available within each classification. It is also true and perhaps somewhat disconcerting, that with every new connector introduced comes the need for another family of adapters.

### 9.3. Usual Two-Port Representations of Adapters

In any situation involving adapters, where impedance is a critical parameter, it may be necessary to take into account the effect of the adapter. This in itself is not difficult and can be done by a number of well known procedures as follows:

- a. Uniform Transmission Line (Distributed parameter representation)

The adapter can be described in terms of the characteristic impedance  $Z_0$ , propagation constant  $\gamma$ , and the electrical length  $\ell$ , if  $Z_0$  and  $\gamma$  are constant throughout the length of the adapter (see fig. 9-1).

In this situation the adapter can be taken into account by the following relationships (neglecting losses):

- (a) Load impedance known and input impedance required:

$$Z_i = \frac{Z_0 Z_L + jZ_0^2 \tan \beta \ell}{Z_0 + jZ_L \tan \beta \ell} \quad (9-1)$$

- (b) Input impedance known and load impedance required:

$$Z_L = \frac{Z_0 Z_i - jZ_0^2 \tan \beta \ell}{Z_0 - jZ_i \tan \beta \ell} \quad (9-2)$$

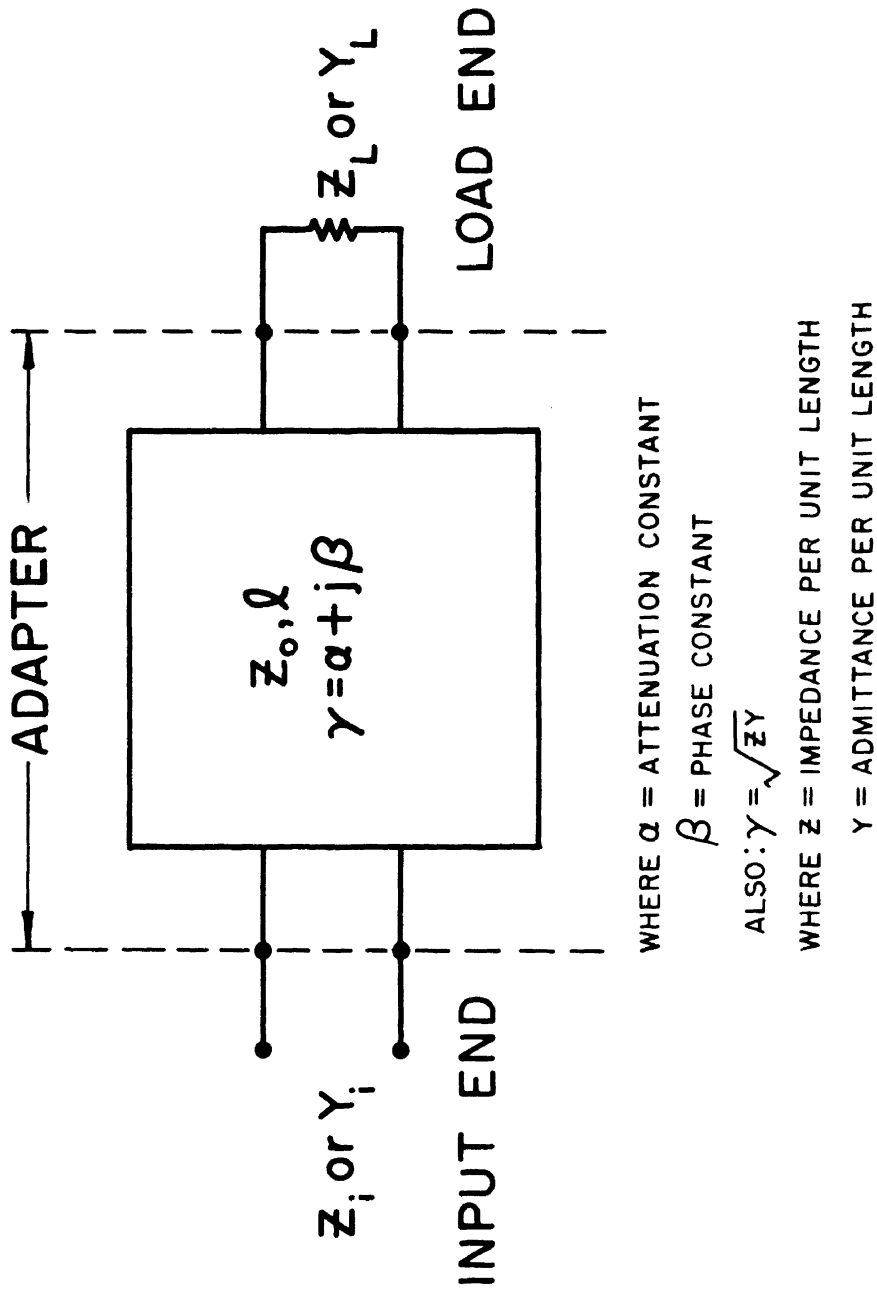

Figure 9-1. Adapter represented as a uniform transmission line

When it is more convenient to work with admittances, the same equations may be used by replacing  $Z_O$ ,  $Z_i$ , and  $Z_L$  by  $Y_O$ ,  $Y_i$ , and  $Y_L$ , respectively.

b. " $\pi$ " or "T" Network (Lumped parameter representation)

See figure 9-2. Because it is usually more convenient to use a  $\pi$ -network representation when working with admittance, the expression for admittance is used:

$$Y_i = Y_A + \frac{Y_B + Y_L}{Z_A(Y_B + Y_L) + 1} \quad (9-3)$$

Because it is usually more convenient to use a T-network representation when working with impedances, the expression for impedance is used:

$$Z_i = Z_A + \frac{Z_B + Z_L}{Y_A(Z_B + Z_L) + 1} \quad (9-4)$$

In these and succeeding equations, series elements are represented as impedances and shunt elements are represented as admittances because it is most convenient to evaluate them in that form.

c. "L" Network (Lumped parameter representation)

With the adapter described as an equivalent L-network, in a "direct" or a "reversed" arrangement figure 9-3, the relationships are:

$$Y_i = \frac{Y_A + Y_L}{Z_A(Y_A + Y_L) + 1} \quad Z_i = Z_A + \frac{Z_L}{Z_L Y_A + 1} \quad (9-5)$$

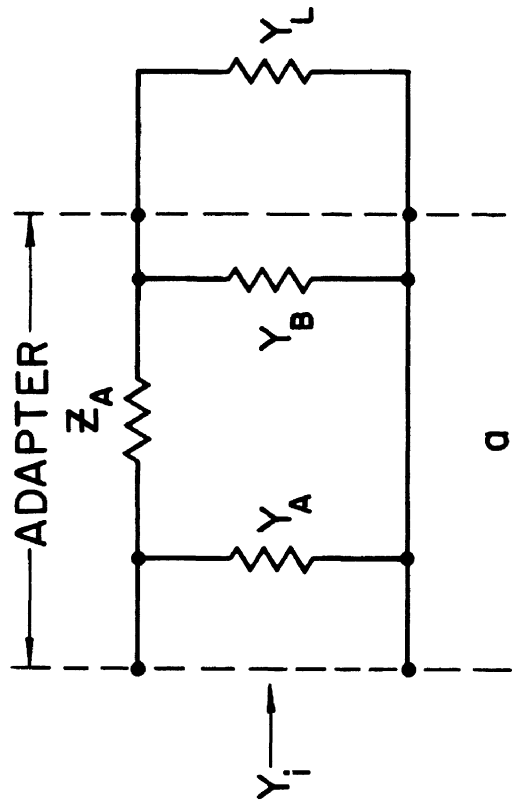
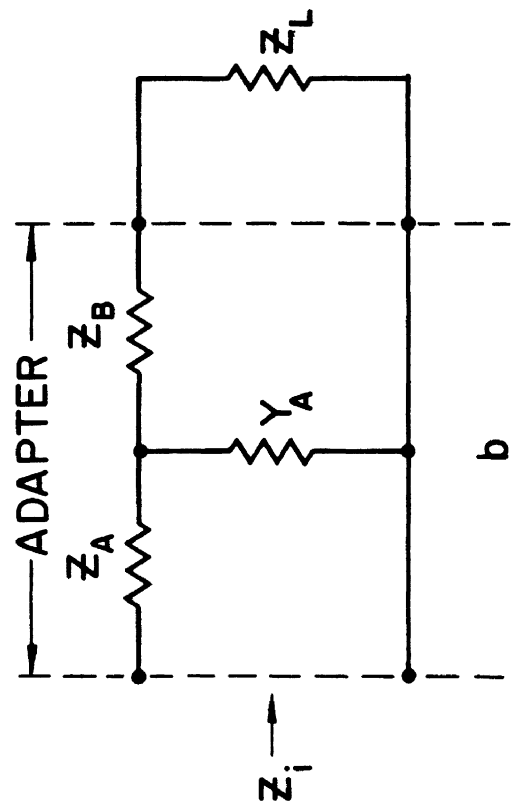

Figure 9-2. Adapter represented as a "π" or "T" network



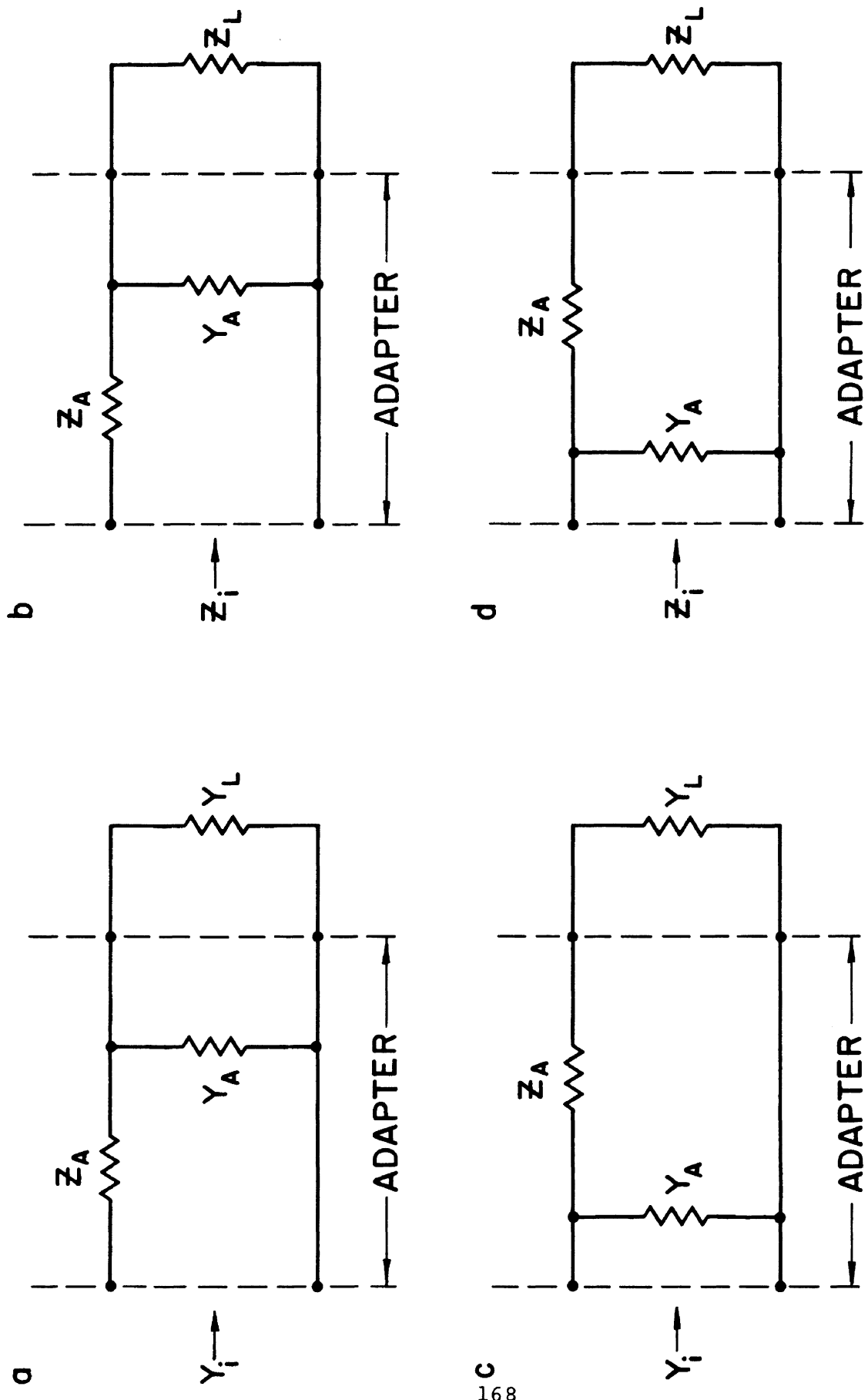

Figure 9-3. Adapter represented as equivalent "L" network

$$Y_i = Y_A + \frac{Y_L}{Z_A Y_L + 1} \quad Z_i = \frac{Z_A + Z_L}{Y_A (Z_A + Z_L) + 1} \quad (9-6)$$

These equations can be used as a test of the validity of using an L-network representation for a particular adapter. For the same measurement, if the equations (9-5) and (9-6) yield results which are different by an unacceptable amount then a more sophisticated equivalent network such as a  $\pi$  or a T would be required. On the other hand if for the same measurement equations (9-5) and (9-6) yield results which do not differ by a significant amount, then it may be adequate to simplify the adapter equivalent circuit to a simple single element representation.

d. Single Element Representation (Lumped parameter representation)

With the adapter described as a single element equivalent as in fig. 9-4:

$$Z_i = Z_A + Z_L \quad Y_i = Y_A + Y_L \quad (9-7)$$

Some general statements can be made about the equivalent network and representations in the foregoing three cases:

(1) Increasing the measurement frequency will generally require increasingly complex equivalent adapter networks to maintain a given limit of uncertainty (for a constant value of  $Z_L$  or  $Y_L$ ).

(2) As measured impedance,  $Z_L$ , becomes larger, the value of the shunt elements in the adapter network become increasingly important (for a constant frequency).

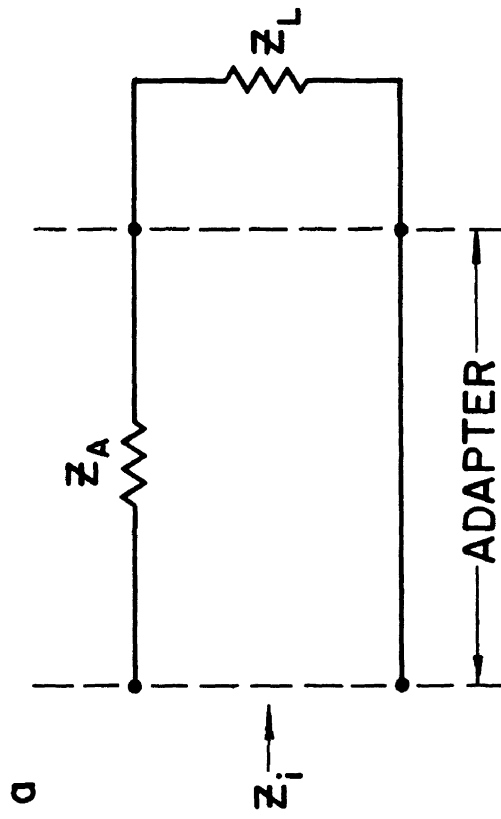
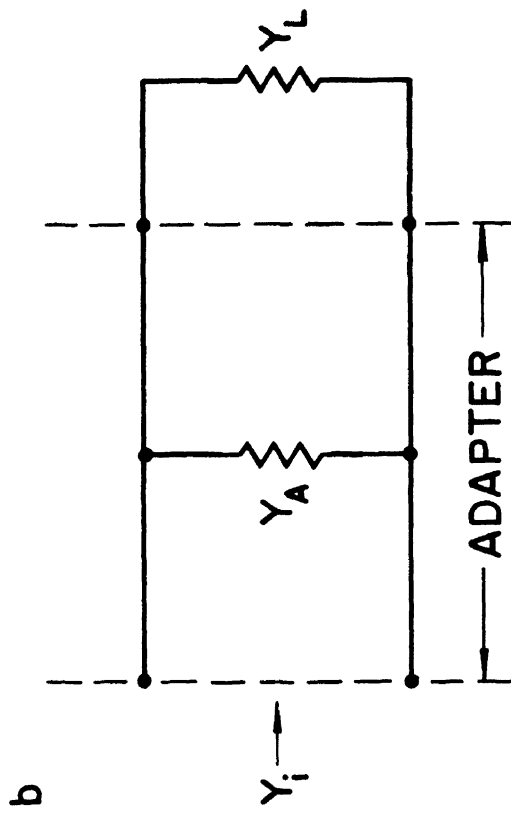

Figure 9-4. Adapter represented as a single element

(3) As measured admittance,  $Y_L$ , becomes larger, the value of the series elements in the adapter network becomes increasingly important (for a constant frequency).

The foregoing cases presuppose that an appropriate equivalent circuit can be representative of a particular adapter and that the immittance elements comprising it are known. Numerous techniques relying either upon low frequency capacitance measurements, electrical length determinations or resonance methods can be employed which aid in determining the approximate values of series or parallel elements of adapter equivalent circuits. These methods, however, are often cumbersome and the uncertainty of the results is difficult to assess. Improvement is needed both in evaluating adapters and in the computational procedures used to correct for them.

#### 9.4. Measurement of Open-Circuit Admittance, Electrical Length, and Short-Circuit Location in Non-Precision Connectors and Adapters

One criterion distinguishing a precision coaxial connector from a non-precision one is that the precision connector has a precisely defined reference plane or plane of cleavage. An alternative interpretation of this criterion is that the open and short-circuit impedances of the precision connector are known accurately. If the open-circuit and short-circuit impedances of non-precision connectors could be determined then this important difference would be eliminated and it would become possible to change or adapt from one connector system to another with practically no added uncertainty due to reference plane location. Such a capability would prove useful in improving traceability between various levels or echelons of measurement and calibration.

Accurate determination of the open-circuit fringe capacitance of various non-precision connectors can be accomplished by a procedure which utilizes a "zero length" adapter. A "zero length" adapter can be used to mate two two-precision connectors of the same sex without adding any significant impedances at the interface, thereby preserving the same electrical conditions that exist when male and female connectors are mated in the usual manner. The technique is useful for most, if not all, of the more common connector systems. For purposes of describing the technique, specific reference will be made to the type-N connector.

The use of a zero length adapter to join two type-N male connectors is illustrated by figures 9-5 and 9-6. In a paper by Millea [70] a "connector pair" technique is described which permits the exact measurement of precision three-terminal to two-terminal adapters. As a preliminary step in the measurement of the open-circuit capacitance of non-precision connectors, the evaluation of two auxiliary three-terminal to two-terminal adapters must be made. Let the capacitance of the two three-terminal to two-terminal adapters be  $C_{ad}$  and  $C'_{ad}$ . These are located in position 1 shown in figure 9-7a, which is the setup to be used in measuring open-circuit capacitances of non-precision connectors. Three separate two-terminal to two-terminal adapters are needed to carry out this experiment. Two of these adapters will have type-N male connectors and a third will have a type N female connector, and all three will be alternately inserted at position 2 of figure 9-7a, at the opposite end of each of these adapters, either a sexless or a hermaphroditic type of connector is required initially to mate with the adapters in position 1.

With the two adapters having type-N male connectors joined by means of a zero length adapter and located in position 2, we can determine the capacitance value

$$C_A + C_B = C_1. \quad (9-8)$$

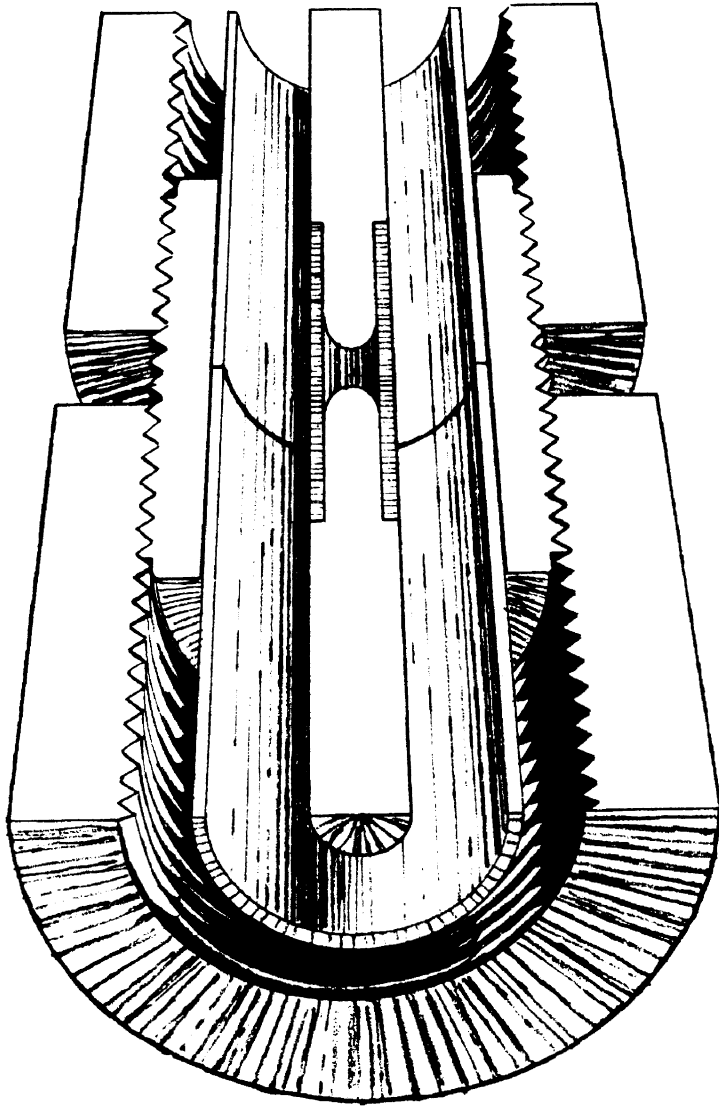

Figure 9-5. Zero-length adapter for type N male connectors  
(cross-section illustration)

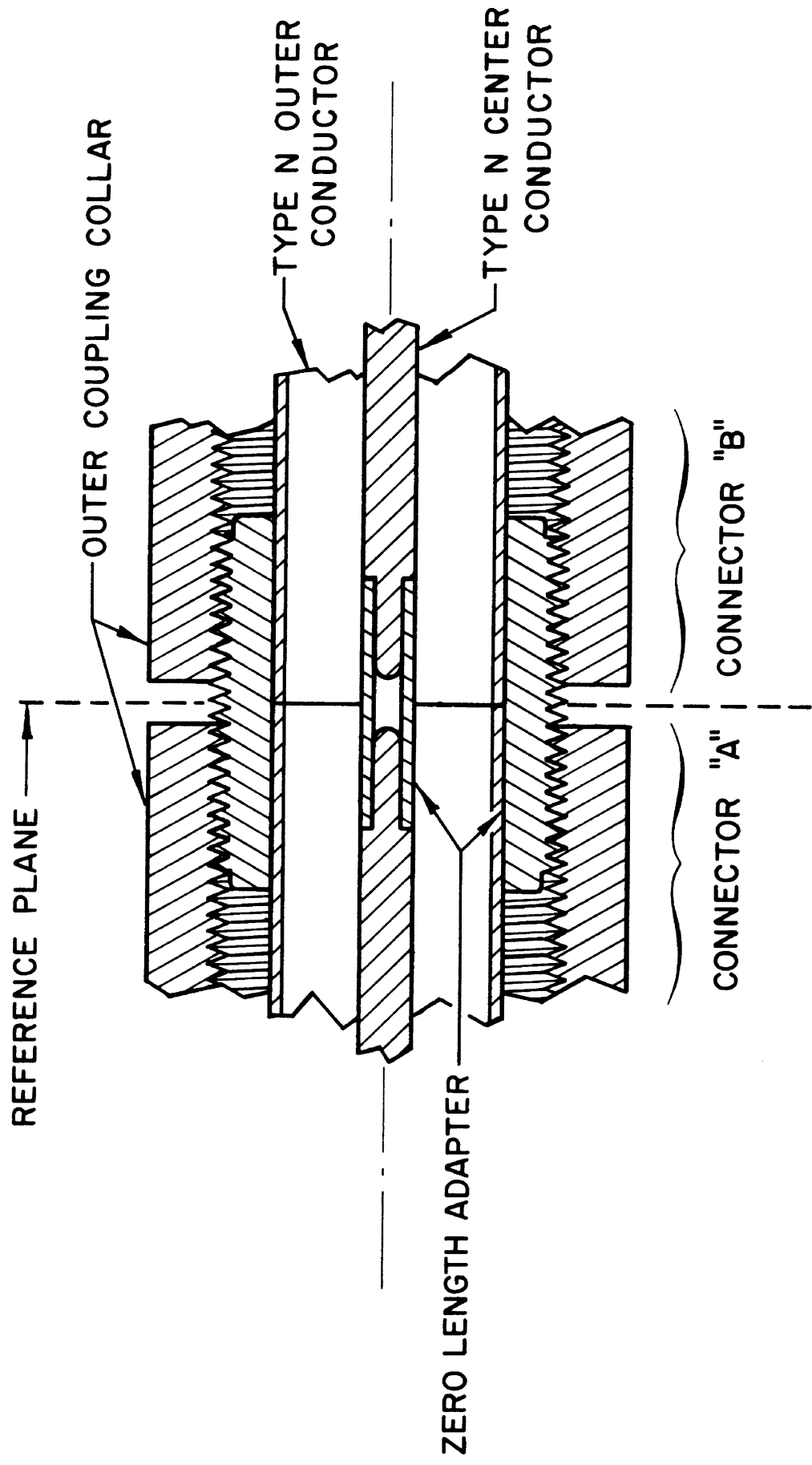
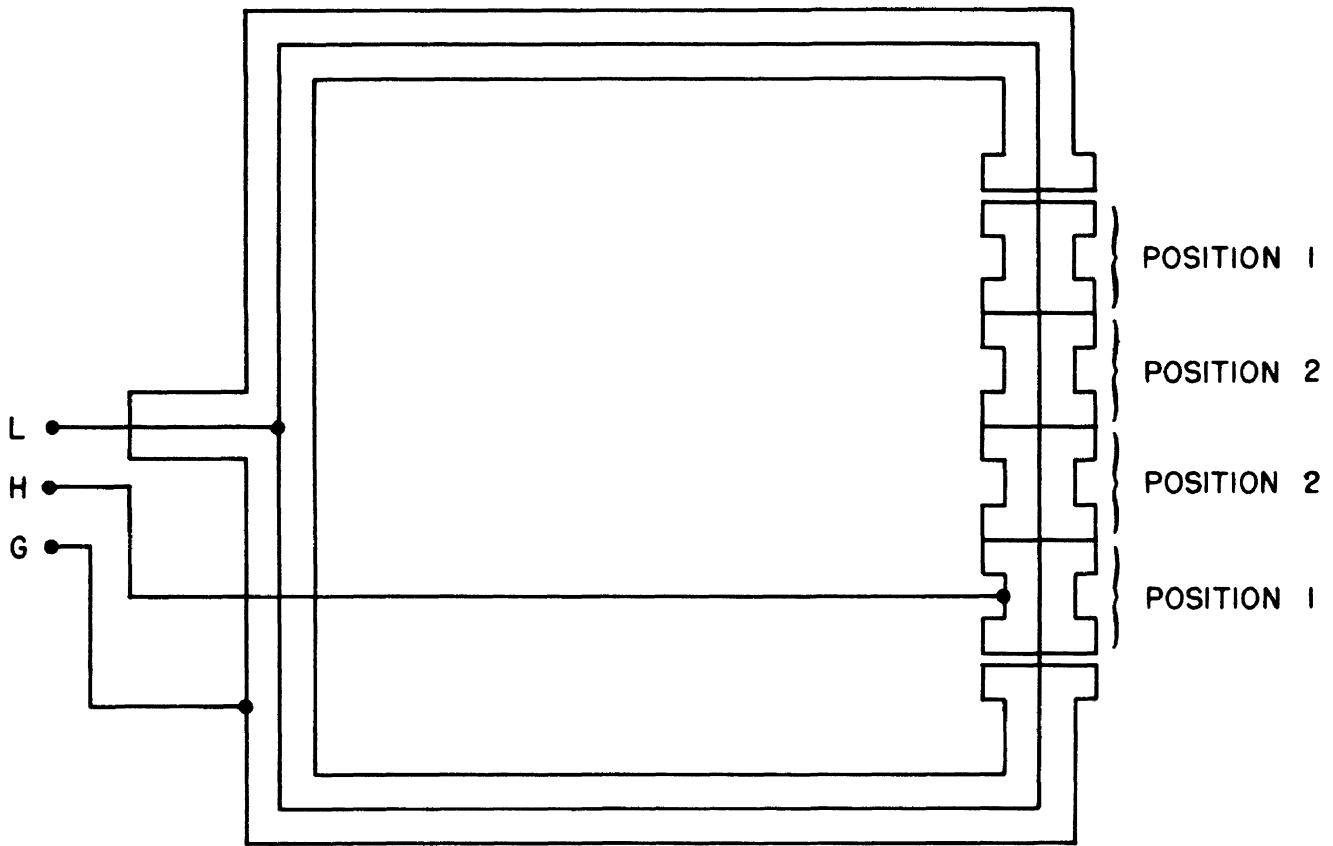
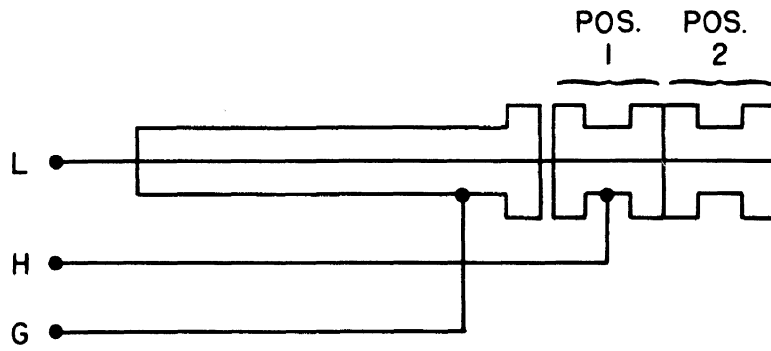

Figure 9-6. Zero-length adapter for type N male connectors (engineering cross-section)



a



b

Figure 9-7. Connection arrangements for measuring adapter capacitances and open-circuit fringe capacitances at 1 kHz



Combining the adapter with the female type-N with the two type-N male adapters gives

$$C_A + C_C = C_2 \quad (9-9)$$

and

$$C_B + C_C = C_3 \quad (9-10)$$

The arrangement of figure 9-7b is then utilized to give the following

$$C_A + C_{fmA} = C_4 \quad (9-11)$$

$$C_B + C_{fmB} = C_5 \quad (9-12)$$

$$C_C + C_{ffc} = C_6 \quad (9-13)$$

where  $C_{fmA}$ ,  $C_{fmB}$ , and  $C_{ffc}$  are the open-circuit (fringe) capacitance of the two type-N male and the type-N female connectors respectively. These equations may then be solved simultaneously to give values for the open circuit capacitances of the type-N connectors and also values for  $C_A$ ,  $C_B$ , and  $C_C$ .

Equations (9-8) through (9-13) may be put into the general form

$$a_{n1}C_A + a_{n2}C_B + a_{n3}C_C + a_{n4}C_{fmA} + a_{n5}C_{fmB} + a_{n6}C_{ffc} = C_n$$

where  $a_{n1} \dots a_{n6}$  are coefficients equal to 1 or 0.

Using determinants:

$$C_{fmA} = \frac{\begin{vmatrix} 1 & 0 & 0 & C_1 & 0 & 0 \\ 1 & 1 & 0 & C_2 & 1 & 0 \\ 0 & 0 & 1 & C_3 & 0 & 1 \\ 1 & 0 & 0 & C_4 & 0 & 1 \\ 0 & 0 & 0 & C_5 & 1 & 1 \\ 0 & 0 & 0 & C_6 & 1 & 0 \end{vmatrix}}{\begin{vmatrix} 1 & 0 & 0 & 1 & 0 & 0 \\ 0 & 1 & 0 & 0 & 1 & 0 \\ 0 & 0 & 1 & 0 & 0 & 1 \\ 0 & 0 & 0 & 1 & 0 & 1 \\ 0 & 0 & 0 & 0 & 1 & 1 \\ 0 & 0 & 0 & 1 & 1 & 0 \end{vmatrix}} \quad (9-14)$$

and in a similar manner the values for  $C_{fmB}$ ,  $C_{ffC}$ ,  $C_A$ ,  $C_B$ , and  $C_C$  are obtained. Upon subtracting  $C_{ad}$  or  $C'_{ad}$  as appropriate from  $C_A$ ,  $C_B$ , and  $C_C$ , the capacitance from the reference plane at one end of the adapter to the reference plane at the other end of the adapter is obtained. This information can be used together with the electrical length, determined with reference to a short circuit, to deduce the characteristic impedance, or conversely, to determine the inductance of an adapting device if its characteristic impedance is known. Although these capacitive adapter parameters are determined at 1 kHz they are useful at much higher frequencies because they are almost invariant to frequencies up to 1 GHz.

There are a number of items pertaining to this measurement technique which require additional discussion. First it is to be noted that the coupling collars of the type N male connectors

extend beyond the end of the outer conductor. In order to join the two type-N male connectors in the manner shown in figures 9-5 and 9-6, it is necessary to cut back one or both of the outer coupling collars by a small amount. The same is true for the BNC, TNC and other connectors, but slightly different approaches are required in making a zero-length adapter for each connector type. In most instances it is better to make a zero-length adapter for two male connectors rather than for the female connectors because one extra piece would be required in the case of the females and also because some difficulties are encountered in arranging an outer coupling device.

The open-circuit fringe capacitance of a connector is apt to be more repeatable if some sort of cap is used instead of merely leaving the end of the connector uncovered. This is due to the possibility of capacitance to surrounding objects. However, because such caps are not available for the male and female connectors in all types, it may be necessary to make the fringe field determinations with the connector ends uncovered. In using the method described by Millea [70], it is advisable to surround the end of the connector by a fairly large (one cubic foot) conducting shield driven at the same potential as the "Hi" electrode of the three-terminal capacitance bridge being used to perform the measurements. This condition most nearly simulates the actual situation encountered when performing two-terminal capacitance measurements.

There are several types of commercially available non-precision coaxial connectors which are sexless. In these instances the zero-length adapter is not necessary for the determination of adaptor capacitance or open-circuit capacitance. In some instances there may be no reference plane which is mechanically identifiable, but it is interesting to note that the foregoing measurement procedure yields a

unique value for open circuit capacitance and thereby defines an electrical reference plane. The extent to which this reference plane is repeatable from one connector to another or from one connector pair to another is determined by the mechanical precision to which they are manufactured. This is true for all connectors.

Once the open-circuit capacitance of one half of a connector pair of any two-electrode connector system is known, it is then possible, by the technique described, to measure the open circuit capacitances of all other connectors of that system whether they be male or female. In other words, the zero-length adapter need only be used once to provide the key to these determinations. With sexless connector systems the zero-length adapter is not required.

In addition to its use in determining open-circuit capacitances of various connector types the "zero length" adapter has additional applications. When evaluating the electrical length of a particular precision-to-non-precision adapter, by slotted line methods, it is convenient to utilize the back-to-back technique and to join identical adapters in the manner shown in figure 9-8.

Using a short-circuit at the outer end of the adapter, unique values of electrical length can be determined for individual adapters taken in any one of the following combinations:

1. Three precision to non-precision male
2. Two precision to non-precision male and one precision to non-precision female
3. Three precision to non-precision female
4. Two precision to non-precision female and one precision to non-precision male.

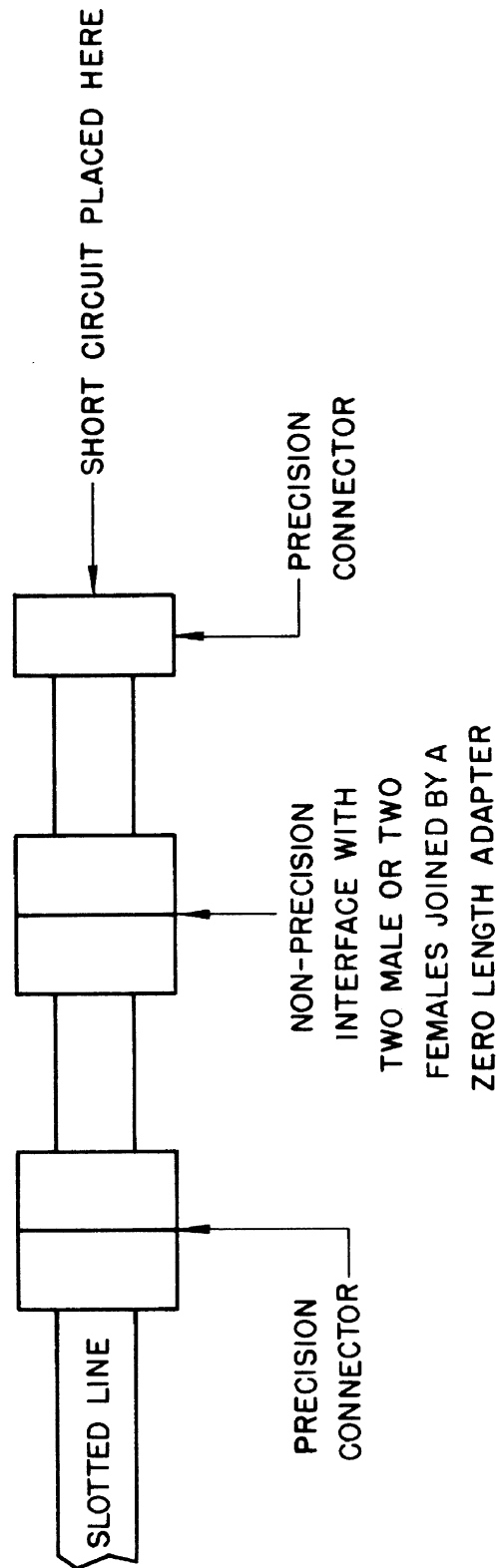

Figure 9-8. Connection arrangement for measuring electrical length of adapter utilizing zero-length adapter.

Such methods can be further extended to include adapters from one non-precision connector type to another, because once a reference plane is determined for a particular non-precision connector, it can be treated as though it were a precision connector. In such cases the essential differences are in the repeatability of the interconnection of individual connector halves within each different connector system, with the repeatability of precision connectors being superior to the non-precision types. Once electrical lengths are determined in this manner, it is then possible to determine the precise location of the short-circuit with respect to the reference plane of a non-precision connector.

## 10. APPENDIX I. DEFINITIONS, UNITS AND SYMBOLS

The definitions which follow are intended as an aid in the use and understanding of this metrology guide, and may be found to differ from definitions found elsewhere. This is done deliberately because of the need to emphasize certain concepts important to understanding the material in the guide. Some elaboration is done in the hope of adding clarity to the term or concept. The terms are arranged alphabetically for quick reference.

- Admittance: Symbol,  $Y / \theta = G + jB$ ; Unit: mho ( $\Omega$ ) - The reciprocal of impedance; usually used for describing parallel arrangements of circuit elements; associated with measurements made with respect to an open-circuit reference.
- Bridge: A network of immittance elements including standards and an unknown immittance to be measured. When the network is energized by a source of voltage the standards may be adjusted until a null or zero transmission condition exists across some portion of the network. At null a unique mathematical relationship exists between the immittance of the unknown and the bridge standards.
- Capacitance: Symbol, C; Unit Farad (F) - That property of a circuit or component of storing energy in an electric field causing the current to lead the voltage by  $90^\circ$ . Capacitance is represented by a positive susceptance ( $+j\omega C$ ) in a parallel circuit or by a negative reactance ( $-j/\omega C$ ) in a series circuit where  $\omega = 2\pi f$  is the angular frequency in radians per second.
- Conductance: Symbol, G; Unit: Siemens (S) or mho ( $\Omega$ ) - That property of a conductor or circuit which causes electric energy to be dissipated in the form of heat. It is the real portion of a passive complex admittance and is ordinarily used in the context of parallel arrangements of circuit elements. Conductance is the equivalent of reciprocal series resistance only when the circuit has no reactance. Conductance is the reciprocal of parallel resistance in all cases, and the two terms are used interchangeably.
- Detector: A device used to sense a null or other response in a measurement circuit enabling the operator to determine the existence of a particular relationship between the standards and the unknown being measured.

Dissipation      Symbol,  $\delta$  - The reciprocal of quality factor,  $Q$  and used to indicate capacitor quality. It is the ratio of conductance to susceptance in a parallel circuit; also known as loss tangent and sometimes stated in percent.

Distributed Parameter:      Implies that circuit dimensions are large enough or that frequencies are high enough so that all circuit elements may be considered as being present in uniform amounts at all locations throughout the circuit as opposed to being concentrated at a single point. Distributed parameter methods are the most exact means of describing a circuit but do not become practical from the standpoint of physical analytical application until circuit dimensions are significant compared to a quarter wavelength of the operating frequency. Uniform circuit geometry is also necessary for the application of distributed parameter analysis.

Generator:      A source of sinusoidal voltage at a particular frequency used to energize a circuit or network for the purpose of performing an impedance measurement.

Inductance:      Symbol,  $L$ ; Unit Henry (H) - That property of a circuit or component of storing energy in a magnetic field and causing the voltage to lag the current by  $90^\circ$ . Inductance is represented by a positive reactance ( $+j\omega L$ ) in a series circuit or by a negative susceptance ( $-j/\omega L$ ) in a parallel circuit where  $\omega$  is the angular frequency in radians per second.

Immittance:      A contraction of the words impedance and admittance used to convey the concept of all magnitudes and phase angles of any impedance or admittance and encompassing both series and parallel circuit representations.

Impedance:      Symbol,  $Z \angle \theta = R + jX$ ; Unit: Ohm ( $\Omega$ ) - The most commonly used definition is the one derived from Ohm's law, namely the ratio of voltage to current ( $Z = E/I$ ). This is called the active definition of impedance. Another definition is also appropriate. This is the passive definition that impedance is a geometrical configuration of materials whose magnitude depends upon a length and the electromagnetic properties of free space(1). The active definition is the one appropriate in most practical measurement applications whereas the standards laboratory must concern itself with the passive concept also. Impedance is most commonly used to describe series arrangements of circuit components and is associated with measurements made with respect to a short-circuit reference.



Impedance (Active): An impedance whose resistance is negative which means that an energy emitter or an energy generating source is present and that for that portion of the circuit which the impedance represents more energy is being emitted than is being dissipated in heat.

Impedance (Passive): An impedance containing only positive resistance. Either no energy sources are present or the circuit can dissipate more energy in the form of heat than the amount being generated.

In situ Measurements: Measurements made on components which are in place in a circuit.

Lumped Parameters: Implies that circuit dimensions are small enough or that frequencies are low enough so that the circuit elements may be considered as being concentrated or lumped at a single location as opposed to being distributed over some finite distance in a circuit. Lumped parameter concepts are never perfectly realizable in practice but are necessary where physical circuit dimensions are small with respect to a wavelength or where the circuit geometry is nonuniform.

Parallel Circuit: An arrangement of elements in a way such that all of the energizing voltage appears across each one.

Phase Angle: Symbol,  $\phi$ , for admittance and  $\theta$ , for impedance; Units degrees or radians - The angle of lead or lag of current with respect to voltage in a parallel circuit,  $\phi$ , or the angle of lead or lag of voltage with respect to current in a series circuit,  $\theta$ .

$$\phi = \tan^{-1} \frac{B}{G} ; \theta = \tan^{-1} \frac{X}{R}$$

Quality Factor: Symbol,  $Q$  - The ratio of the maximum amount of energy stored to the energy dissipated over a unit of time corresponding to one cycle multiplied by  $2\pi$ . This is also commonly called the energy storage factor of a component. The most common usage is in connection with inductors or capacitors and it indicates the degree of purity of the component. It is also very commonly used as a measure of bandwidth or sharpness of tuning or selectivity of a resonant circuit. Voltage multiplication factor is also a commonly used name for this phenomena because the voltage across the output of a tuned circuit is  $Q$  times the input voltage.

**Range:** The extremes of values of a parameter such as frequency or impedance between which an instrument such as a generator, detector or bridge is usable.

**Reactance:** Symbol,  $X$ ; Unit: ohm ( $\Omega$ ) - The imaginary component of a complex impedance which is positive ( $+jX = +j\omega L$ ) if the impedance is inductive and negative ( $-jX = -j 1/\omega C$ ) if the circuit is capacitive. Reactance is most commonly used in the context of series circuit arrangements and is the equivalent of reciprocal susceptance only if the circuit is lossless.

**Resistance (series):** Symbol,  $R_s$ ; Unit: ohm ( $\Omega$ ) - That property of a conductor or circuit which causes electric energy to be dissipated in the form of heat. It is the real portion of a passive complex impedance and is ordinarily used in the context of series circuits. It is the equivalent of reciprocal conductance or parallel resistance only when the circuit has no reactance or susceptance.

**Resistance (parallel):** Symbol,  $R_p$ ; Unit: ohm ( $\Omega$ ) - The reciprocal of conductance and also equal to series resistance in circuits with no reactance or susceptance.

**Resonance (series):** The condition in a series circuit where the positive and negative reactances are equal, the current and voltage are in phase and current is at a maximum. The circuit at series resonance is purely resistive and the impedance is at a minimum.

**Resonance (parallel):** The condition in a parallel circuit where the positive and negative susceptances are equal, the current and voltage are in phase and the voltage is at a maximum. The circuit at parallel resonance is purely resistive and the admittance is at a minimum.

**Self-resonance:** The frequency at which an inductor reaches parallel resonance with its own distributed capacitance or a capacitor reaches series resonance with its own series inductance.

**Susceptance:** Symbol,  $B$ ; Unit: Siemens (S) or mho ( $\Upsilon$ ) - The imaginary component of a complex admittance which is positive ( $+jB$ ) if the circuit is capacitive and negative ( $-jB = -j 1/\omega L$ ) if the circuit is inductive. Susceptance is used in the context of parallel circuits.

**Three-Terminal:** A measurement made in such a way that the results include only the admittance between two conductors with the effects of other conductors in the vicinity

being excluded. Primarily used in the evaluation of very small capacitances.

**Two-Terminal:** The impedance or admittance of a point in a circuit to ground. Such measurements include the effects contributed by all other conductors or objects in the vicinity of the measurement, i.e., near enough to be detected.

## 11. BIBLIOGRAPHY

1. High Frequency Impedance Standards at The National Bureau of Standards  
Powell, R. C., R. M. Jickling and A. E. Hess  
IRE Trans. Instrumentation  
Dec. 1958, Vol. I-7, Nos. 3 & 4, 270-274
2. Alternating Current Bridge Methods  
Hague and Ford  
Pitman, (BATH) 6th Edition  
1971
3. Radio Frequency Measurements by Bridge and Resonance Methods  
Hartshorn, L.  
John Wiley & Sons, New York  
1943
4. Parallel-Resonance Methods for Precise Measurements of High Impedances at Radio Frequencies and a Comparison With the Ordinary Series-Resonant Methods  
Sinclair, D. B.  
Proceedings IRE  
Dec. 1938, Vol. 26, No. 12, 1466-1497
5. Electronic Measurements and Instrumentation  
Oliver, B. M., J. M. Cage, and  
Clyde F. Coombs, Jr. (editors)  
Inter-University Electronics Series  
(McGraw-Hill Book Company)  
1971, Vol. 12, Chapter 9, 264-318
6. Measure Impedance the Easy Way, Use A Vector Voltmeter  
Heck, J. R.  
Electronic Engineer  
Dec. 1970, Vol. 29, No. 12, 54-57
7. Measurement of Complex Impedance 1-1000 MHz  
-  
Hewlett Packard Application Note 77-3  
Apr. 1, 1967, 11 pages
8. The Measurement of the Permittivity and Power Factor of Dielectrics at Frequencies from  $10^4$  to  $10^8$  Cycles Per Second  
Hartshorn, L. and W. H. Ward  
J. IEE(London)  
Nov. 1936, Vol. 79, 597-609

9. Impedance Measurements at High Frequencies With Standard Parts  
Sinclair, D. B.  
G. R. Experimenter  
Sept. 1939, Vol. XIV, No. 4, 1-8
10. Precise Measurement of Dielectric Properties at Radio Frequencies  
Reddish, W., Mrs. A. Bishop and P. J. Hyde  
Proceedings IEE(London)  
Jan .1971, Vol. 118, No. 1, 255-265
11. Analysis and Experimental Evaluation of the Immittance Transcomparator  
Agy, D. L.  
University of Colorado Library(Masters Thesis)  
1970
12. Digital Q-Meter WDM  
Durbeck, B.  
News from Rohde & Schwarz(Germany)  
1970, Vol. 10, No. 45, 20-22
13. Standards For the Calibration of Q-Meters - 50 kHz to 45 MHz  
Jones, R. N.  
NBS Journal of Res. Sec. C. Eng. & Inst.  
Oct.-Dec. 1964, Vol. 68C, No. 4, 243-248
14. A Transcomparator for High-Q Immittance Measurements  
Agy, D. L. and R. E. Nelson  
Electronic Instrument Digest  
Jan. 1971, Vol. 7, No. 1, 37-40
15. A Technique for Extrapolating the 1 Kc Values of Secondary Capacitance Values to Higher Frequencies  
Jones, R. N.  
NBS Tech. Note No. 201  
Nov. 5, 1963, 12 pages
16. Electrical Measurement Analysis  
Frank, Ernest  
McGraw-Hill, New York  
1959
17. A Precision, High Frequency Calibration Facility for Coaxial Capacitance Standards  
Jones, R. N. and L. E. Huntley  
NBS Tech. Note No. 386  
Mar. 1970, 27 pages
18. Impedance Bridges for the Megacycle Range  
Wilhelm, H. T.  
Bell System Technical Journal  
Sept. 1952, Vol. 31, 999-1012

19. Handbook of Electronic Measurements  
Wind, M. (editor)  
Polytechnic Institute of Brooklyn, Brooklyn, N. Y.  
1956, Vol. 1, Ch. 4, 4-8 to 4-56
20. A Radio Frequency Bridge for Impedance Measurements from  
400 Kilocycles to 60 Megacycles  
Sinclair, D. B.  
Proceedings IRE  
Nov. 1940, Vol. 38, No. 11, 497-503
21. A 1-Megacycle Schering Bridge  
Easton, I. G.  
G. R. Experimenter  
Feb. 1952, Vol. XXVI, No. 9, 1-4
22. New R-F Bridge Features Small Size and Added Operating  
Convenience  
Soderman, R. A.  
G. R. Experimenter  
June 1955, Vol. 30, No. 1, 5-9
23. A Wide Range VHF Impedance Meter  
Mennie, John H.  
The Boonton Radio Corporation Notebook  
Summer 1964, No. 2, 1-4
24. Some VHF Bridge Applications  
Reimenschneider, N. L.  
Boonton Radio Corporation Notebook  
Summer 1955, No. 6
25. A Coaxial Adaptor for the RX Meter  
Gorss, C. G.  
Boonton Radio Corporation Notebook  
Fall 1954, No. 3
26. Transmission Line Measurements With the RX Meter  
Reimenschneider, N. L.  
Boonton Radio Corporation Notebook  
Fall 1954, No. 3
27. The Transformer Ratio-Arm Bridge  
Calvert, R.  
Wayne-Kerr, Philadelphia, PA.  
Monograph No. 1, 11 pages
28. An Improved Bridge for Precision Measurements  
Voelker, W. D.  
Bell Laboratories Record  
Jan. 1942, 133-137

29. Accurate Immittance Measurements at Frequencies up to 20 MHz  
White, Lowell D.  
IEEE Trans. Instrumentation & Measurement  
Nov. 1970, Vol. IM-19, No. 4, 331-336
30. A New Technique in Bridge Measurements  
Calvert, R.  
Electronic Engineering  
Jan. 1948, Vol. XX, 28-29
31. AC Bridge Methods for the Measurement of Three-Terminal Admittances  
Thompson, A. M.  
IEEE Trans. Instrumentation & Measurement  
Dec. 1964, Vol. IM-3, No. 4, 189-197
32. The Measurement of Lumped Immittance at RF  
McCartney, T.  
Joint Conference on R.F. Measurements  
and Standards  
Nov. 1967
33. Standard High-Frequency Meter for IPDO-3 Solid Dielectrics  
Abrosimov, E. A.  
Measurement Techniques  
June 1971, Vol. 14, No. 6, 844-898
34. Measurements of Electrical and Magnetic Quantities  
Bikulov, A. P. and P. M. Frolov  
Izmeritel'naya Tekhnika  
May 1968, No. 5, 643-647
35. The Measurement of Transistor Parameters on Wayne-Kerr RF Bridges  
Scarlet, R. M.  
Wayne-Kerr, Phila., PA. 3-9
36. Bridged-T and Parallel-T Null Circuits for Measurements at Radio Frequencies  
Tuttle, W. N.  
Proceedings IRE  
Jan. 1940, Vol. 28, 23-29
37. The Twin-T A New Type of Null Instrument for Measuring Impedance at Frequencies up to 30 MHz  
Sinclair, D. B.  
Proceedings IRE  
July 1940, Vol. 28, 310-318

38. A Self-Calibrating Instrument for Measuring Conductance at Radio Frequencies  
Huntley, L. E.  
NBS Journal of Res. Sec. C. Eng. & Instr.,  
Apr.-June 1965, Vol. 69C, No. 2, 115-126
39. A Precision Dual Bridge for the Standardization of Admittance at Very High Frequencies  
Woods, D.  
Proceedings IEE(London)  
June 1957, Vol. 104C, Mono. 244R, 506-521
40. Standards for Electrical Circuit Properties at Radio Frequencies: A Survey of some U.K. Developments  
Harris, I. A.  
Radio Electronic Engineer(Great Britian)  
Apr. 1968, Vol. 35, No. 4, 189-198
41. Method and Apparatus For Measuring Q of a Reactive Element in a Bridge Circuit  
Bara, S.  
U.S. Patent No. 3,523,242  
Issued Aug. 4, 1970
42. Handbook of Coaxial Microwave Measurements  
Gray, D. A.  
General Radio Company  
West Concord, Mass. 01781, 163 pages
43. A Direct-Reading Impedance-Measuring Instrument for the UHF Range  
Thurston, W. R.  
G. R. Experimenter  
May 1950, Vol. 24, No. 12
44. Improved Accuracy and Convenience of Measurements With Type 1602B Admittance Meter in VHF and UHF Bands  
Soderman, R. A.  
G. R. Experimenter  
Aug. 1953, Vol. 28, No. 3
45. Wide-Range Transfer-Function and Immittance Device for Measurements in the VHF/UHF Ranges  
Buhn, U.  
Electronic Engineering (Great Britian)  
July 1968, Vol. 40, 394-396
46. Impedance Measurement in the 50 to 2000 Mc Range  
Soderman, R. A.  
Radio Electronic Engineering  
July 1951, 3-6



47. Measuring Inter-Electrode Capacitances  
Young, C. H.  
Bell Labs Record  
Dec. 1946, Vol. XXIV, No. 12, 433-438
48. A Null Method for Determination of Impedance in the  
100-400 Mc Range  
Byrne, J. F.  
Proceedings of the Natl. Elec. Conf. (Chicago)  
1947, Vol. 3, 603-614
49. Direct Measurement of Impedance in the 50-500 Mc  
Range  
Fong, A.  
Hewlett-Packard Journal  
Apr. 1950, Vol. 1, 4 pages
50. A Versatile Instrument - The Q-Meter  
Cook, L.  
Boonton Radio Corporation Notebook  
Winter 1954, No. 4
51. Circuit Magnification Meter  
Parkyn, J. M.  
Marconi Instrumentation  
March 1959, Vol. 7, No. 1, 8-16
52. The Development of Q-Meter Methods of Impedance  
Measurement  
Briggs, A. J. and J. E. Houldin  
Proceedings IEE(London)  
July 1949, Vol. 96, Pt. III, 295-305
53. The Story of Q  
Green, E. I.  
American Scientist  
Oct. 1955, Vol. 43, No. 4, 584-594
54. The Q-Meter and Its Theory  
Rao, V. V. L.  
Proceedings IRE  
Nov. 1942, Vol. 30, 502-505
55. The Nature of Q  
Moore, W. C.  
Boonton Radio Corporation Notebook  
Spring 1954, No. 1
56. Measurement of Dielectric Materials and Hi-Q Capacitors  
With the Q-Meter  
Reimenschneider, N. L.  
Boonton Radio Corporation Notebook  
Winter, 1956, No. 8

57. Direct-Reading, Fully-Automatic Vector Impedance Meters  
Alonzo, G. J., R. H. Blackwell and H. V. Marantz  
Hewlett-Packard Journal  
Jan. 1967, Vol. 18, No. 5, 12-18
58. Lumped Parameter Impedance Measurements  
Huntley, L. E. and R. N. Jones  
Proceedings IEEE  
June 1967, Vol. 55, No. 6, 900-911
59. Precision Coaxial Connectors in Lumped Parameter Immittance Measurement  
Jones, R. N. and L. E. Huntley  
IEEE Trans. Inst. & Meas.  
Dec. 1966, Vol. IM-15, No. 4, 375-380
60. Calibration and Test Services of The National Bureau of Standards  
-  
NBS Special Publication 250  
Dec. 1970, 209 pages
61. Electrical Parameters of Precision, Coaxial, Air Dielectric Transmission Lines  
Nelson, R. E. and M. R. Coryell  
NBS Monograph 96  
June 30, 1966, 103 pages
62. Errors in the Measurement of Capacitance and Inductance  
Dabrowski, G.  
News from Rohde & Schwarz  
1967, Vol. 7, No. 28, 48-49
63. Coaxial Impedance Standards  
Kempf, R. A.  
Bell System Technical Journal  
July 1951, Vol. 30, 689-705
64. Immittance Transformation Using Precision Air-Dielectric Coaxial Lines and Connectors  
Woods, D.  
Proceedings IEE(London)  
Nov. 1971, Vol. 118, No. 11, 1667-1674
65. The Realization of High Frequency Impedance Standards Using Air-Spaced Coaxial Lines  
Harris, I. A. and R. E. Spinney  
IEEE Trans. Inst. & Meas.  
Dec. 1964, Vol. IM-13, 265-272

66. Air-Filled Coaxial Lines as Absolute Impedance Standards  
Weinschel, B. O.  
Microwave Journal  
Apr. 1964, Vol. 17, No. 4, 47-50
67. Skin-Effect Corrections in Immittance and Scattering  
Coefficient Standards Employing Precision Air-Dielectric  
Coaxial Lines  
Zorzy, J.  
IEEE Trans. Instr. & Meas.  
Dec. 1966, Vol. IM-15, No. 4, 358-364
68. Radio Engineers Handbook  
Terman, F. E.  
McGraw-Hill Book Co.,  
New York & London  
1943, 1019 pages
69. Some Applications for Series Impedance Elements in Radio  
Frequency Immittance Measurements  
Huntley, L. E.  
NBS Journal of Res. Sec. C. Eng. & Inst.,  
July-Dec. 1970, Vol. 74C, Nos. 3 & 4, 79-85
70. Connector-Pair Techniques for the Accurate Measurement  
of Two-Terminal Low-Value Capacitances  
Millea, A.  
NBS Journal of Res. Sec. C. Eng. & Inst.,  
July-Dec. 1970, Vol. 74C, Nos. 3 & 4, 111-116
71. The 6-Port Coupler; A New Approach to Measuring Voltage,  
Current, Power, Impedance and Phase  
Hoer, C. A.  
IEEE Trans. Instrumentation & Measurement  
Nov. 1972, Vol. IM-21, No. 4, 466-470
72. Five-Terminal, 1 MHz Automatic Capacitance Bridge  
Sette, R. F.  
General Radio Experimenter  
Nov./Dec. 1969, Vol. 43, Nos. 11 & 12, 6-7
73. Microwave Theory and Applications  
Adam, S.  
Prentice-Hall Inc., Englewood Cliffs, N. J.  
1964, 513 pages
74. Choosing An Automated Test System  
Ewy, M. O. and S. C. Shank  
Hewlett-Packard Journal  
Aug. 1969, Vol. 20, No. 12, 7-10

75. Time Domain Reflectometry  
 Oliver, B. M.  
 Hewlett-Packard Journal  
 Feb. 1964, Vol. 15, No. 6, 1-7
76. Impedance Measurements in Coaxial Waveguide Systems  
 Jesch, R. L. and R. M. Jickling  
 Proceedings IEEE  
 June 1967, Vol. 55, No. 6, 912-923
77. Broadband Resistive-Divider-Type Directional Coupler  
 Hoer, C. A. and D. L. Agy  
 IEEE Trans. Instrumentation & Measurement  
 Nov. 1970, Vol. IM-19, 336-343
78. Swept-Frequency Techniques  
 Ely, P. C. Jr.,  
 Proceedings IEEE  
 June 1967, Vol. 55, No. 6, 991-1001
79. Precision Capacitance Measurements With a Slotted Line  
 Zorzy, J. and M. J. McKee  
 G. R. Experimenter  
 Sept. 1967, Vol. 41, No. 9, 10-11
80. Present Day Simplicity In Broadband VSWR Measurements  
 Oldfield, W. W.  
 Wilton Technical Review  
 July 1970, Vol. 1, No. 1, 1-8

U.S. DEPT. OF COMM. BIBLIOGRAPHIC DATA SHEET	1. PUBLICATION OR REPORT NO. NBS-MONOGR. 141	2. Gov't Accession No.	3. Recipient's Accession No.
4. TITLE AND SUBTITLE The Measurement of Lumped Parameter Impedance; A Metrology Guide		5. Publication Date June 1974	6. Performing Organization Code
7. AUTHOR(S) R. N. Jones		8. Performing Organization	
9. PERFORMING ORGANIZATION NAME AND ADDRESS  NATIONAL BUREAU OF STANDARDS DEPARTMENT OF COMMERCE Boulder, Colorado 80302		10. Project/Task/Work Unit No. 2729103	11. Contract/Grant No.
12. Sponsoring Organization Name and Address  Same as 9 above.		13. Type of Report & Period Covered Final	14. Sponsoring Agency Code
15. SUPPLEMENTARY NOTES  Library of Congress Catalog Card Number: 74-8060			
16. ABSTRACT (A 200-word or less factual summary of most significant information. If document includes a significant bibliography or literature survey, mention it here.)  The measurement of two-terminal impedance in the 30 kHz to 300 MHz range involves a variety of different methods including null, resonance, active and comparison. Each method is represented by a number of instruments having specific capabilities, strengths, and weaknesses. This metrology guide is intended to assist the scientist who is not intimately familiar with impedance measurement, in the selection and use of the best instrument for a particular requirement. Information is included on range and accuracy capabilities as well as availability and ease of operation. In addition to providing help in the selection of the appropriate instrument, there are operating tips which enhance accuracy, criteria for choosing standards, means for extending normal measurement range of an instrument, a discussion on generators and detectors, and a section on the evaluation and use of adapters. Finally, an extensive bibliography is included to assist in pursuing a particular problem beyond the depth of the guide.			
17. KEY WORDS (Alphabetical order, separated by semicolons) Adapters; capacitance; capacitors; detectors; generators; impedance instruments; impedance standards; inductance; inductors; measurement methods; reactance; resistance; resistor; standards.			
18. AVAILABILITY STATEMENT  <input checked="" type="checkbox"/> UNLIMITED.  <input type="checkbox"/> FOR OFFICIAL DISTRIBUTION. DO NOT RELEASE TO NTIS.		19. SECURITY CLASS (THIS REPORT)  UNCLASSIFIED	21. NO. OF PAGES  211
		20. SECURITY CLASS (THIS PAGE)  UNCLASSIFIED	22. Price  \$5.50

READER'S COMMENT AND MAILING LIST FORM

Your comments, accompanied by answers to the following questions, help us produce better publications for your use. If your answer to a question is "No" or requires qualification, please explain in the space provided below.

	Yes	No	No Opinion
Does this publication meet your needs?	<input type="checkbox"/>	<input type="checkbox"/>	<input type="checkbox"/>
Did you find the material:			
Easy to read and understand?	<input type="checkbox"/>	<input type="checkbox"/>	<input type="checkbox"/>
Organized for convenient Use?	<input type="checkbox"/>	<input type="checkbox"/>	<input type="checkbox"/>
Complete?	<input type="checkbox"/>	<input type="checkbox"/>	<input type="checkbox"/>
Arranged for convenient reference?	<input type="checkbox"/>	<input type="checkbox"/>	<input type="checkbox"/>
Written for your technical level?	<input type="checkbox"/>	<input type="checkbox"/>	<input type="checkbox"/>
How do you use this publication?			
As an introduction to the subject?	<input type="checkbox"/>	<input type="checkbox"/>	<input type="checkbox"/>
For advanced knowledge of the subject?	<input type="checkbox"/>	<input type="checkbox"/>	<input type="checkbox"/>
For information about operating procedures?	<input type="checkbox"/>	<input type="checkbox"/>	<input type="checkbox"/>
As an instructor in a class?	<input type="checkbox"/>	<input type="checkbox"/>	<input type="checkbox"/>
As a reference manual?	<input type="checkbox"/>	<input type="checkbox"/>	<input type="checkbox"/>
Other _____			

COMMENTS

What other Metrology Guides would be useful to you or your organization? Your comments will aid us in selecting topics of future guides.

- Attenuation Measurements
- Near Field Measurements including Radiation Hazard Measurements
- RF Power and Voltage Measurements
- One-port Noise Source Evaluation
- Transducers as applied to Precision Electrical Measurements
- Time Domain Measurements
- Field Strength Measurements
- Anechoic Chambers Performance evaluation
- Shielded Enclosure Evaluation
- Automated Precision Electrical Measurements
- Network Analyzers applied to Precision Electrical Measurements
- Other (please specify) \_\_\_\_\_

Would you like your name on a MAILING LIST to receive information about future Metrology Guides? If so, please complete the following.

Name \_\_\_\_\_

Title \_\_\_\_\_

Department \_\_\_\_\_

Company \_\_\_\_\_

Address \_\_\_\_\_

City \_\_\_\_\_ State \_\_\_\_\_

Zip Code \_\_\_\_\_

Send this form to:

W. J. Anson  
 Electromagnetic Metrology  
 Information Center  
 National Bureau of Standards  
 Boulder, Colorado 80302